











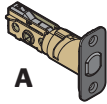
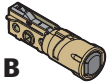





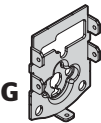

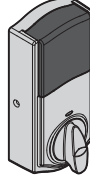
Required tools	Parts in the box					
Ruler  Phillips screwdriver 	Latch with rectangular faceplate  A	Drive-in latch  B	Strike  C	Exterior assembly  D	Adapter ring  E	Keys  F
Additional tools (depending on application) Hammer  Wood block 	Mounting plate  G	Interior assembly  H	Battery pack  J	Interior cover  K	Batteries  L	SmartKey tool  M
	Latch screws  N P 03809	Strike screws  Q R 46780	Mounting plate screws  T		Interior assembly screws  U 49191	Interior cover screws  V 64109

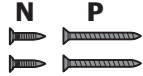
Note: Part numbers are printed on screw bags.

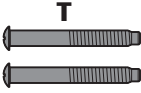
1 Prepare the door and check dimensions

If drilling a new door, use the supplied template and the complete door drilling instructions available at www.kwikset.com/doorprep.

- A** Measure to confirm that the hole in the door is either 2-1/8" (54 mm) or 1-1/2" (38 mm).

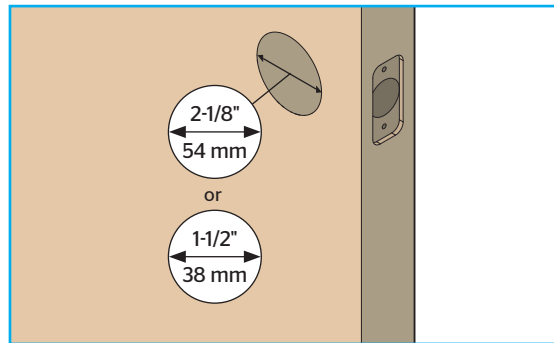

Note: Additional door preparation may be required for doors with 1-1/2" (38 mm) holes. Consult the deadbolt drilling instructions at www.kwikset.com/doorprep

- B** Measure to confirm that the backset is either 2-3/8" or 2-3/4" (60 or 70 mm).

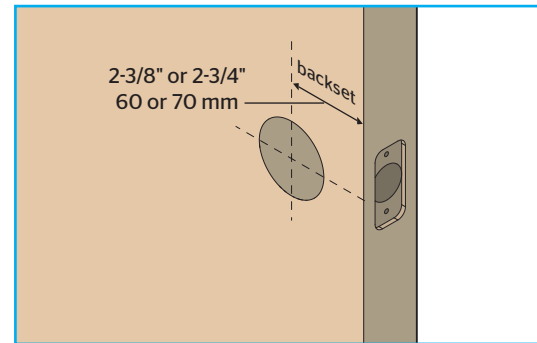

- C** Measure to confirm that the hole in the door edge is 1" (25 mm).

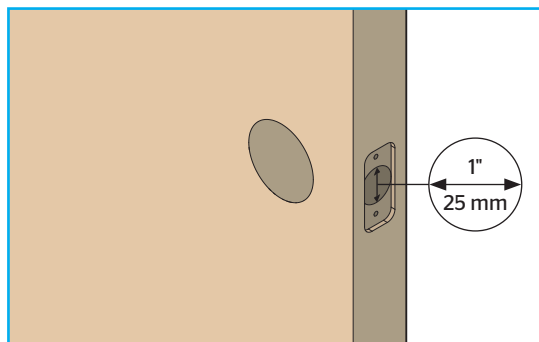

- D** Measure to confirm that the door is 1-3/4" (44 mm) thick.

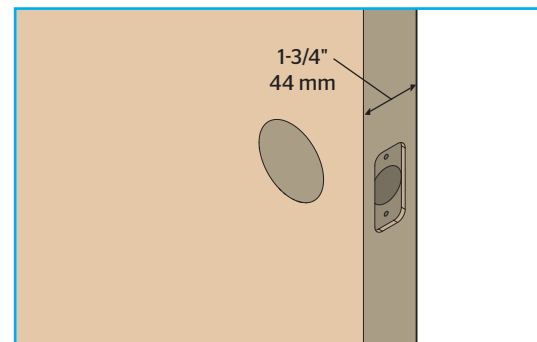

2

Install the latch and strike

A Is the door edge chiseled?

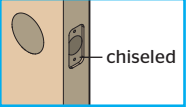
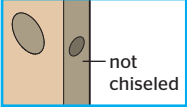
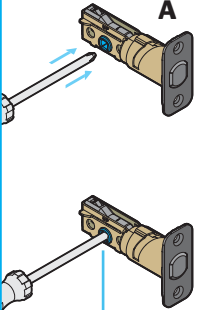
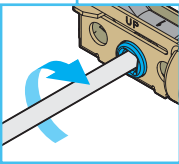
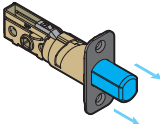
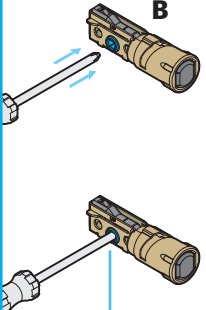
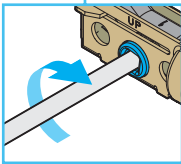
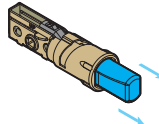
YES	or	NO
 <p>chiseled</p>		 <p>not chiseled</p>
<p>Use latch "A". If the latch bolt is not already extended, extend the latch bolt as shown.</p>   		<p>Use latch "B". If the latch bolt is not already extended, extend the latch bolt as shown.</p>   

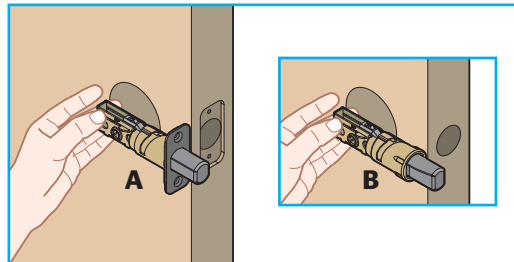

B Hold the latch in front of the door hole, with the latch face flush against the door edge.

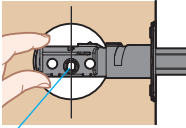
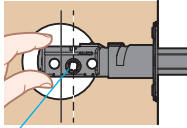
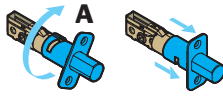
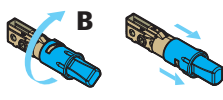

C Is the D-shaped hole centered in the door hole?

YES	or	NO
 <p>D-shaped hole centered</p>		 <p>D-shaped hole NOT centered</p>
<p>No adjustment is required. Proceed to next step.</p>		<p>Rotate latch face as shown to extend latch.</p>  

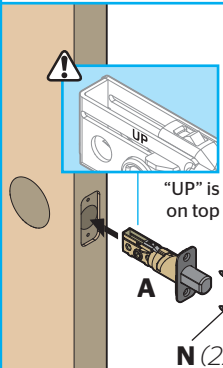
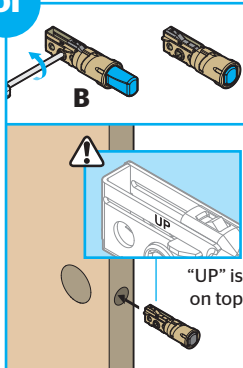
D Which latch are you installing?

Latch "A"	or	Latch "B"
 <p>"UP" is on top</p> <p>A</p> <p>N (2x)</p>		 <p>"UP" is on top</p> <p>B</p>
		 <p>wood block</p>

E Install strike on the door frame.

⚠ Make sure the hole in the door frame is drilled a minimum of 1" (25 mm) deep.

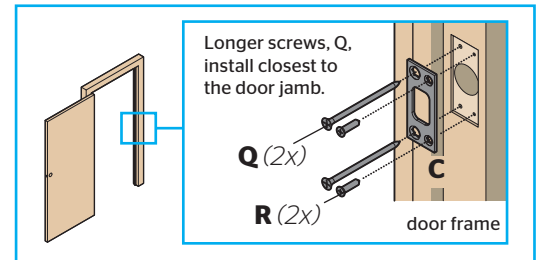

Longer screws, Q, install closest to the door jamb.

Q (2x)

R (2x)

door frame

Note: The longer screws, Q, (3" / 76 mm) must be used to maintain highest security.

3

Install the exterior assembly

A What is the diameter of the hole in the door?

Diameter is 2-1/8" (54 mm)

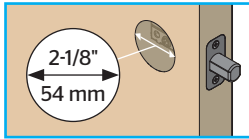

"E" is required for installation. Install "E" on "D".

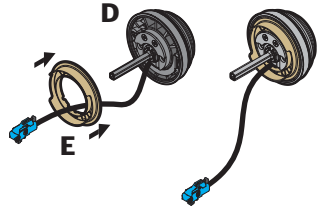

Diameter is 1-1/2" (38 mm)

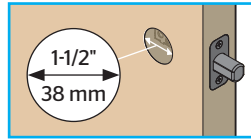

"E" is not needed for installation. Discard "E".



B Locate mounting screws and keep them within reach.

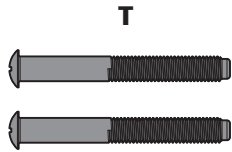

C Install exterior assembly and mounting plate.

a Locate mounting plate (G). Note: It is on the back of the interior assembly.

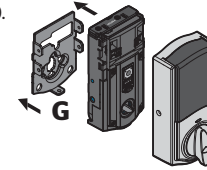

b Cable goes underneath latch.

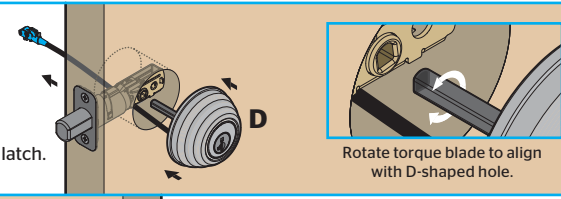

c Route cable through center hole, then push cable into bottom hole.

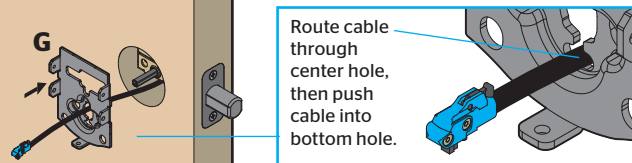

d Tighten screws evenly (T (2x)). Keep parallel to edge of door.

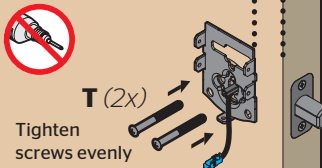

e Insert key and test latch. If latch does not extend or retract smoothly, adjust screws (T). Remove key when finished and make sure the latch bolt is fully extended.

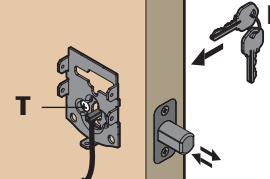

4 Install the interior assembly

A Remove battery cover and battery pack from interior assembly.

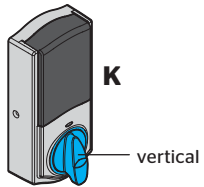
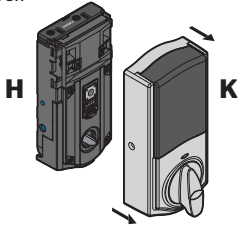
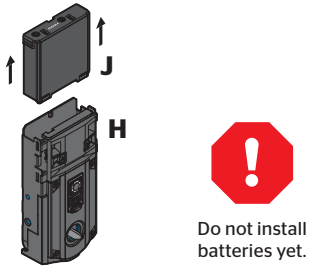
<p>a Make sure turnpiece is in the vertical position.</p> 	<p>b Remove interior cover.</p> 	<p>c Remove battery pack.</p>  <p>Do not install batteries yet.</p>
--	---	---

B Connect cable and install interior assembly.

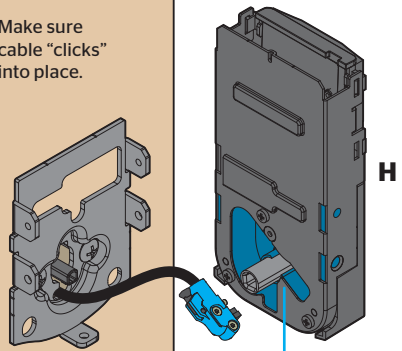
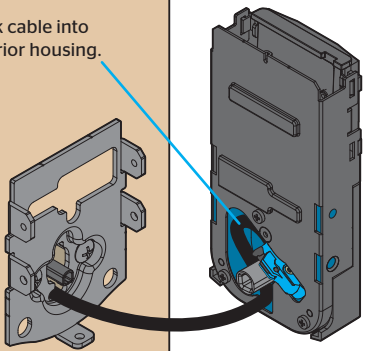
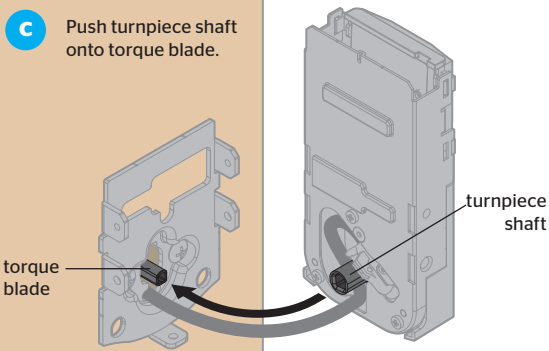
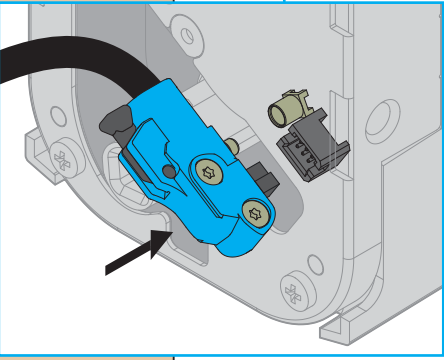
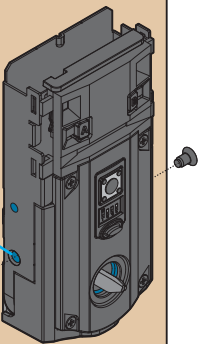
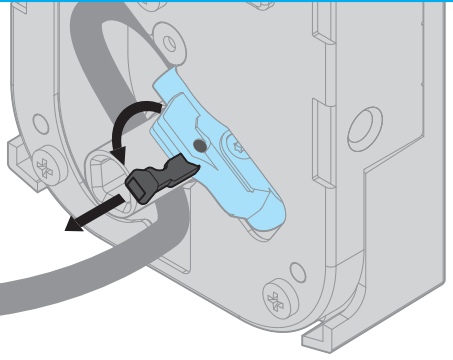
<p>a Make sure cable "clicks" into place.</p> 	<p>b Tuck cable into interior housing.</p> 	<p>c Push turnpiece shaft onto torque blade.</p> 
	<p>d Secure with screws.</p>  <p>bottom hole</p> <p>U (2x)</p>	<p>Tip Use lever if you need to remove cable.</p> 

5 Perform the door handing process

This step will teach the lock the orientation of your door and is crucial for lock operation.

A Install 4 AA batteries in the battery pack.

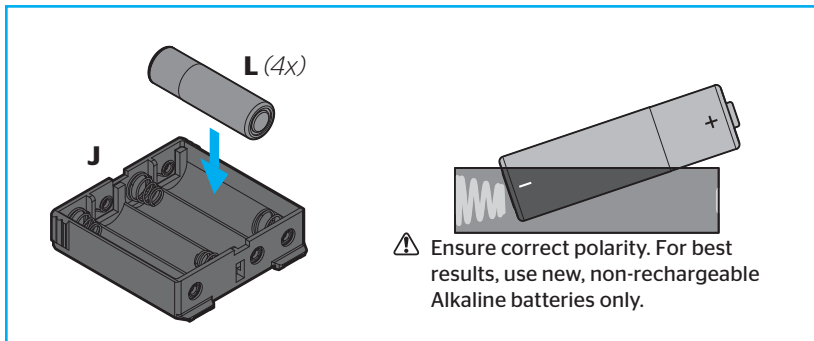

B **IMPORTANT:** Make sure the door is open. Insert the battery pack while **PRESSING AND HOLDING** the Program button. Release the button when the battery pack is all the way inside the lock interior.

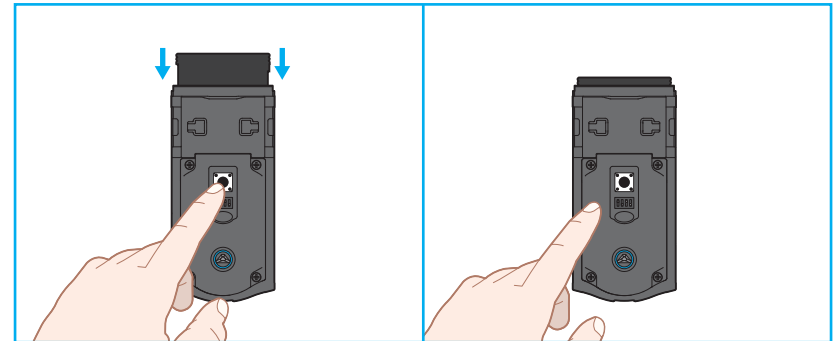

C **IMPORTANT:** The Status LED will flash red and green, and the lock will beep. Press and release the Program button again. The latch bolt will retract and extend on its own.

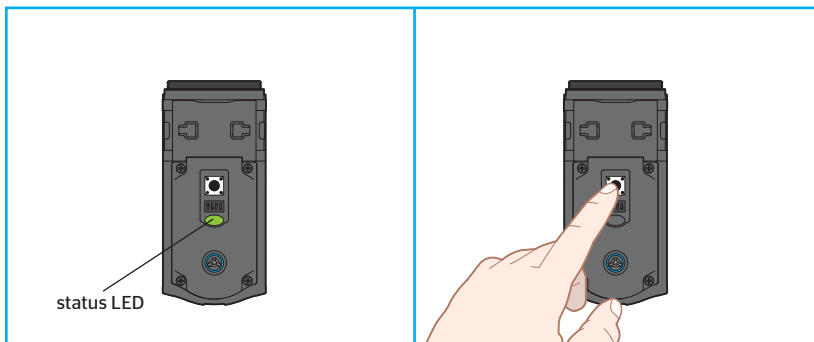

D Did the latch bolt retract and extend on its own?

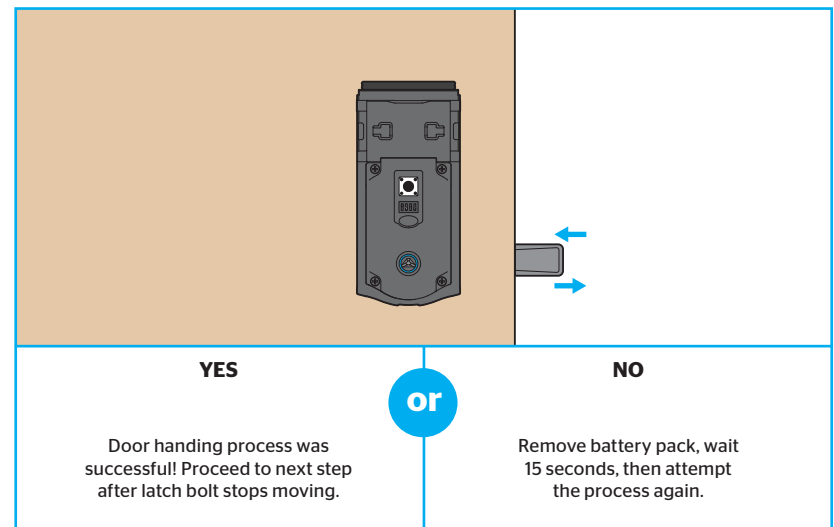

6 OPTIONAL: Re-key the lock

If desired, the lock may be re-keyed to work with your existing key. See the supplied SmartKey Re-key instructions for more information.

7 Download the app and set up your smartphone

A Download the Kevo app at kwikset.com/kevo/app or scan the QR code below.



B Follow the instructions inside the app to create an account, enroll your first smartphone and send eKeys to family and friends.



Normal use

When using your phone to lock and unlock the door, make sure the phone is on, Bluetooth is enabled, and the Kevo app is running in the background.

You may hold the phone in your hand, pocket, bag or purse as long as there is a clear line of sight between the lock and the phone.

First 10 Touches

Your first 10 touches will teach your Kevo smart lock about your entryway and the typical positions where you might keep your phone during normal use.

Kevo may take longer to lock and unlock during this learning phase. After the first 10 touches Kevo has learned about your home's environment and customized itself to the best performance.

See "Positioning Technology" on page 11 for more information.



Locking the door

Touch the deadbolt rose. The light ring will spin blue, spin amber, then flash amber, and you will hear one beep. The door will lock.

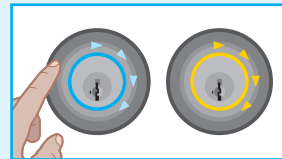

Unlocking the door

Touch the deadbolt rose. The light ring will spin blue, spin green, then flash green, and you will hear two beeps. The door will unlock.

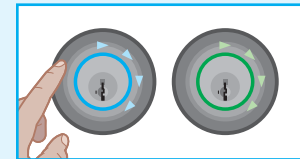

8

Install the interior cover

Important information about the interior cover:

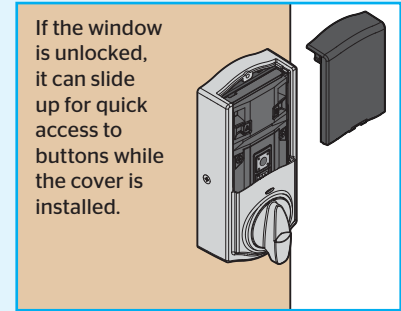
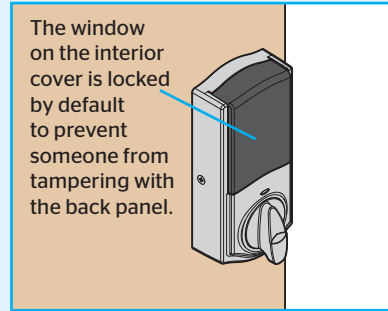
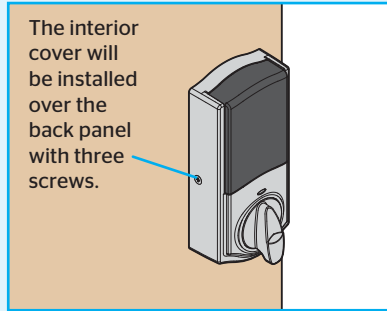
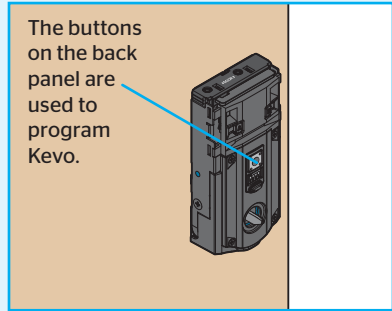

If you want to keep the window locked:

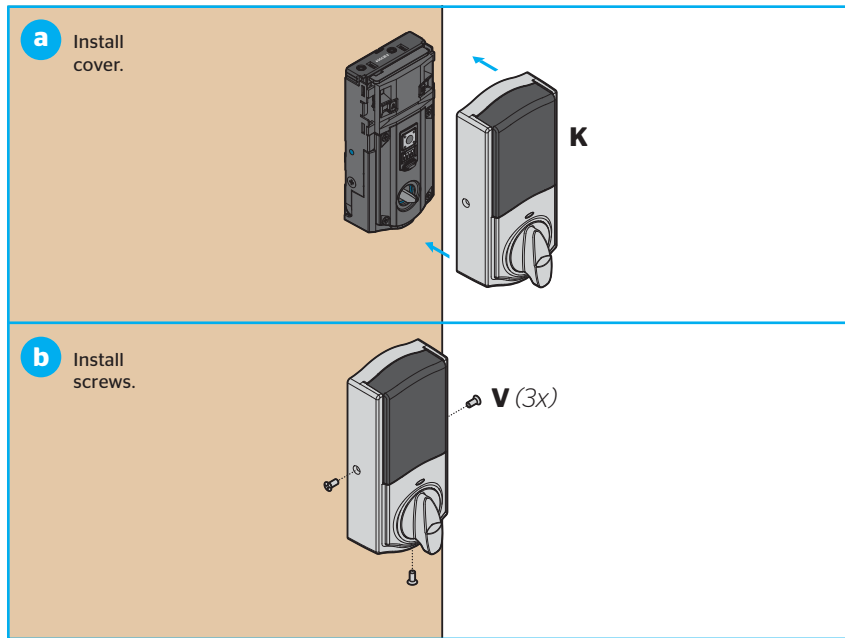

If you want to unlock the window (for quick access to back panel):

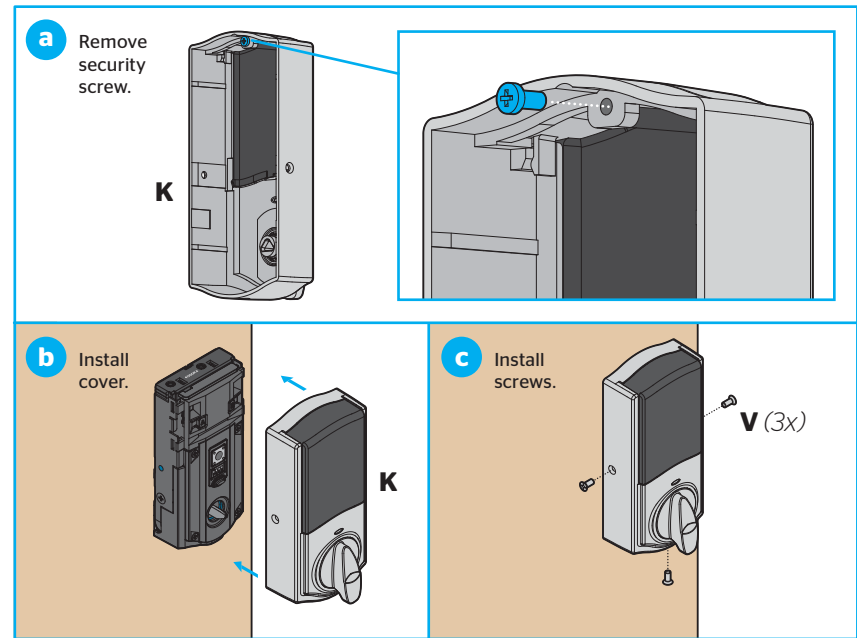

Kevo at a Glance

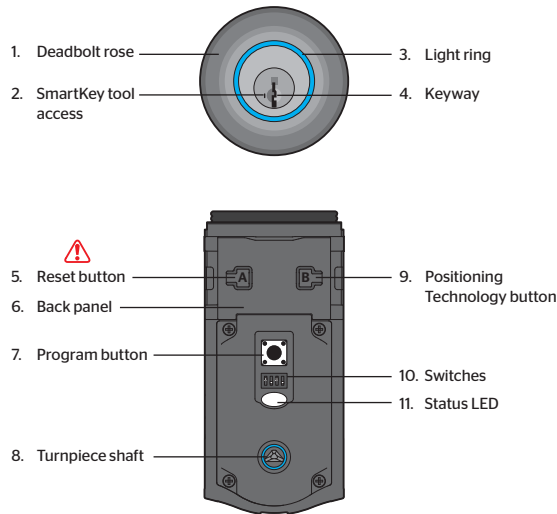

1. Touch Kevo anywhere on the metallic surface behind the light ring to lock and unlock.
2. Insert your SmartKey tool here when rekeying your lock to work with your existing key.
3. Changes color to communicate with you.
4. Insert your standard key here.
5. ⚠️ Only use to reset Kevo to delete all eKeys and fobs. See "System Reset" for more information.
6. Where all the programming features are located.
7. Use to enroll phones and fobs.
8. Engages with turnpiece when interior cover is installed. When the cover is removed, the turnpiece shaft can be used to manually lock and unlock the door.
9. Use to reset calibration that was learned during first 10 touches to the deadbolt rose.
10. Use to enable and disable the Status LED, Triple Touch Lock, Audio, and Auto-Lock.
11. Communicates whether the door is locked or unlocked and flashes red for a low battery alert. Can be turned on and off by Switch #1.

Kevo-Compatible Devices

Smartphones and Smart Devices

A Kevo-compatible smartphone (or other mobile internet-connected device or tablet) must have Bluetooth Smart Ready/ Bluetooth 4.0 and an app specific to the device must be installed. Find out if your device is compatible at www.kwikset.com/kevo/devices.



Kevo Fob

A Kevo Fob is a Bluetooth device that provides the same touch-to-open convenience as a smartphone.

Up to eight fobs can be enrolled in a single Kevo lock. A single fob can be enrolled in up to 25 different Kevo locks.

Note: You may choose to use only Kevo fobs, only smartphones or a mix of both in your Kevo system.

Standard Key

Always make sure you have access to your standard key.

Switches



Switch 1 Status LED

Door lock status LED blinks every 6 seconds. ON position is factory default.

Switch 2 Triple Touch Lock

See "Triple Touch Lock." OFF position is factory default.

Switch 3 Audio

Beeping sound is heard during programming and normal operation. ON position is factory default.

Switch 4 Auto-Lock

Automatically re-locks door 30 seconds after unlocking. OFF position is factory default.

Triple Touch Lock and Auto-Lock

Triple Touch Lock allows you to lock the door from the outside without the use of a smartphone or fob. You might use Triple Touch Lock if you are using only a standard key in your system but wish to lock the door by touch, if your smartphone or fob is disabled, or if you have a visitor in your home that will leave and lock the door behind them.

To lock the door with this feature, touch the deadbolt rose three times, pausing briefly between each touch. The light ring will spin blue, spin amber, then flash amber, and you will hear one beep (if switch #3 is on).

To enable Triple Touch Lock, set Switch #2 to the ON position.

Auto-Lock will automatically re-lock the door 30 seconds after unlocking. To enable Auto-Lock, set Switch #4 to the ON position.

Both features are OFF by default.

⚠️ **CAUTION:** With these feature enabled, it is possible to lock yourself outside if you don't have an enrolled smartphone, Kevo fob or standard key with you.

System Reset

⚠️ **WARNING:** Resetting your Kevo system will restore your lock to factory settings and delete all smartphones and fobs from Kevo's memory.

If you wish to perform a system reset, **press and hold** the Reset button on the back panel for 10 seconds until the lock beeps and the light ring flashes red.

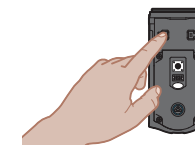

Phones: After a system reset, you will need to re-enroll and your Owner phone. You will still be able to send eKeys at no charge to anyone who previously had an active eKey at the time of reset.

Fobs: After a system reset, all fobs will need to be re-enrolled. See the online Troubleshooting guide for instructions.

Light Ring Notifications



Blue Spinning and Shutting Off: Kevo is unable to establish a connection with your device, and it will not lock or unlock. Make sure that your Bluetooth and Bluetooth Sharing (inside your phone's privacy settings) are enabled, and make sure you are signed in to your Kevo app and that it's running in the background.

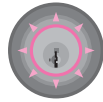

Magenta Flash: Your device is outside of the activation range that was established during your first 10 touches, and it will not lock or unlock. See "Positioning Technology" on page 11. When locking and unlocking your door, make sure there is a clear line of sight between the lock and your device.

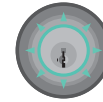

Teal Flash: Kevo was tapped while the door was already opening or closing.

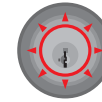

Red Flash: Kevo has detected an unauthorized device within activation range, and it will not lock or unlock. An unauthorized phone is one with the Kevo app installed that does not have an eKey to your lock, and an unauthorized fob is one that has not been enrolled in your Kevo system.

Red Light Ring Warnings



Top Two LEDs are Solid Red: The AA batteries in the Kevo interior are low and need to be replaced.



Bottom LED is Solid Red: The fob battery (CR2025) is low and needs to be replaced. See the online Troubleshooting Guide at www.kwikset.com/kevo/support.

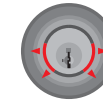

Side LEDs Flashing Red: The deadbolt has jammed. Check your door for alignment and make sure the latch bolt can operate smoothly.

Status LED Notifications

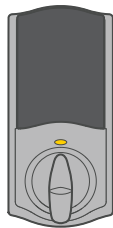

Amber flash
Door is locked

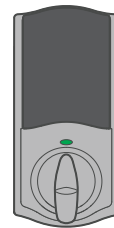

Green flash
Door is unlocked.

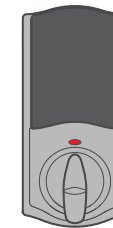

Red flash
The 4 AA batteries in the Kevo interior are low and need to be replaced.

Advanced Features

Positioning Technology

The Kevo smart lock features a unique positioning technology that can tell if your device is inside or outside your home to help prevent your door from being unlocked by unauthorized users while your device is inside.

For additional security, Kevo will also limit the activation range on the outside. During the first 10 touches, the Kevo smart lock will learn about your entryway and the typical positions where you might keep your phone during normal use.

Kevo may take longer to lock and unlock during this learning phase. After the first 10 touches, Kevo has learned about your home's environment and customized itself to the best performance.

If you find that the Kevo activation range is not ideal for your use, you can reset what Kevo learned, and Kevo will learn your environment again. Quickly press and release the Positioning Technology button on the lock interior. Kevo will learn your environment again during the next 10 touches.

History Log

A history of the lock's activity may be viewed through the Kevo app or by logging into the web portal: www.mykevo.com.

Notifications

The Kevo app can send notifications when the door is locked and unlocked by eKey holders. You can choose to receive the system's default notifications or set up custom notifications to monitor a specific user or time frame.

Dual Factor Authentication

Kevo features an optional, added-security passcode that you can enable inside the app to be used in addition to the app's password. Enabling the passcode will require you to enter a 4-digit PIN whenever you access the app, and it protects your Kevo account against unauthorized changes when your phone is unlocked.

Kevo Plus

With Kevo Plus, you will be able to lock and unlock your home and check whether your door is locked or unlocked when you are away from home. You can upgrade to Kevo Plus inside the Kevo app. Visit www.kwikset.com/kevo/kevo-plus for more information.

Connect Smart Products

Connect Kevo to select smart products. In the Kevo app, tap the gear icon to connect to smart products (iOS only: select "Preferences"). Visit www.kwikset.com/kevo/support for more information.

Important Safeguards

1. Read all instructions in their entirety.
 2. Familiarize yourself with all warning and caution statements.
 3. Remind all family members of safety precautions.
 4. Always have access to your lock's standard key.
 5. If using the Triple Touch Lock or Auto-Lock features, make sure to have your smartphone, fob or standard key with you to prevent locking yourself out.
 6. Familiarize yourself with all light ring error notifications.
 7. Replace low batteries immediately.
 8. If your smartphone is lost or stolen, use the Kevo web portal (www.mykevo.com) to disable it.
 9. If a fob in your Kevo system is lost or stolen, reset your lock to delete it from memory.
- have not been altered without your knowledge.
3. Protect the password to your Kevo app and web portal accounts.
 4. When sending an eKey, always double-check that you are sending it to the correct recipient.
 5. Protect and restrict access to your smartphone so that your app settings cannot be altered without your knowledge.
 6. Enable the Kevo app's security passcode so that your app settings cannot be altered without your knowledge.
 7. When sending eKeys, be aware of the difference between an Admin user and other users in the system: an Admin user can send, disable and delete eKeys.

Preventing Inadvertent Unlocking of Your Door

WARNING: Failure to follow these safeguards could result in your lock opening inadvertently.

1. Avoid keeping and storing phones and fobs unnecessarily close to the lock when inside the home.
2. Restrict access to your Kevo lock's back panel and routinely check your settings to ensure they

CAUTION: As with any radio-based technology, it should be noted that the accuracy and reliability of the Kevo lock's inside-outside sensor cannot be guaranteed. Users should not rely solely on the Kevo lock's sensor for security purposes and should always use caution. This manufacturer assumes no responsibility for incorrect results or damages resulting from the use of the Kevo lock's sensor.

Certain home configurations may impede the Kevo lock's sensor more than others. Example: *Your home office is located next to your entryway, and part of the office extends past the front door, jutting into the front yard. If your device is being actively used in that office extension, the Kevo lock's sensor could possibly detect the device as being outside of your home while that device is in active use.*

WARNING: This Manufacturer advises that no lock can provide complete security by itself. This lock may be defeated by forcible or technical means, or evaded by entry elsewhere on the property. No lock can substitute for caution, awareness of your environment, and common sense. Builder's hardware is available in multiple performance grades to suit the application. In order to enhance security and reduce risk, you should consult a qualified locksmith or other security professional.

Need Help?

www.kwikset.com/kevo/support



1-800-327-5625



1-800-327-5625



1800 623 118



0800 736 776



52-8141709475



56-229382400



57-13441460



+86 755298331111



+65 - 666 55 888 office • +65 - 8181 8989 mobile



+65 - 666 55 888 office • +65 - 8181 8989 mobile



Terms and Conditions Términos y condiciones Termes et conditions

Conformité réglementaire

Ce produit est conforme aux normes établies par les organismes de réglementation suivants :

- Federal Communications Commission (FCC)
- Industrie Canada

FCC

Cet appareil est conforme aux limites prescrites dans la partie 15 des règlements de la Federal Communication Commission (FCC) des États-Unis. Son utilisation est subordonnée aux conditions suivantes : (1) l'appareil ne doit pas causer d'interférence nuisibles, et (2) il doit accepter toute interférence, y compris celles qui peuvent causer son mauvais fonctionnement.

Lors des tests effectués, cet appareil s'est révélé conforme aux limites prescrites dans la partie 15 des règlements de la Federal Communications Commission (FCC) des États-Unis pour un appareil numérique de Classe B. Ces limites ont été fixées pour protéger raisonnablement les installations résidentielles contre les interférences nuisibles. L'appareil produit, utilise et peut émettre des radiofréquences. S'il n'est pas installé et utilisé de la façon prescrite, il peut brouiller les communications radio. Il n'est pas garanti qu'aucune interférence ne se produira. Si l'appareil brouille la réception d'une radio ou d'un téléviseur (pour savoir s'il est à l'origine du brouillage, il suffit de l'éteindre et de le rallumer), l'utilisateur est invité à tenter de corriger la situation en prenant une ou plusieurs des mesures suivantes :

- réorienter ou déplacer l'antenne réceptrice;
- éloigner davantage l'appareil émetteur du récepteur;
- brancher l'appareil dans une prise reliée à un circuit différent de celui auquel le récepteur est relié;
- consulter le détaillant ou un technicien de radiotélévision expérimenté pour obtenir de l'aide.

IMPORTANT! Les modifications qui n'ont pas été expressément approuvées par le fabricant de l'appareil peuvent annuler l'autorisation d'utiliser l'appareil.

Industrie Canada

Cet appareil est conforme aux normes d'Industrie Canada exemptes de licence RSS. L'opération est sujette aux deux conditions: (1) ce dispositif peut ne pas causer l'interférence et (2) ce dispositif doit accepter n'importe quelle interférence, y compris l'interférence qui peut causer le fonctionnement non souhaité du dispositif.

Cumplimiento Normativo

Este producto cumple con las normas establecidas por los siguientes organismos reguladores:

- Comisión Federal de Comunicaciones (FCC)
- Industry Canada

FCC

Este dispositivo cumple con la 15ª parte del reglamento de la FCC. Su funcionamiento está sujeto a las siguientes dos condiciones: (1) este dispositivo no deberá causar ninguna interferencia dañina, y (2) este dispositivo deberá aceptar cualquier interferencia recibida, incluyendo aquella que podría causar un funcionamiento no deseado.

Se realizaron pruebas a este equipo cuyos resultados revelaron que cumple con los límites establecidos para un dispositivo digital de la Clase B, conforme a la 15ª parte del reglamento de la FCC. Estos límites han sido impuestos para proporcionar protección razonable contra interferencias dañinas en una instalación residencial. Este equipo genera, utiliza y puede irradiar energía de radiofrecuencia y, si no se instala y utiliza según lo que indican las instrucciones, podría causar interferencia dañina en radiocomunicaciones. Sin embargo, no hay garantía de que la interferencia no ocurrirá en determinadas instalaciones. Si este equipo efectivamente causa interferencia en la recepción de radio o televisión, la cual puede determinarse encendiendo y apagando el equipo, sugerimos al usuario que intente corregir dicha interferencia tomando una o más de las siguientes medidas:

- Volver a orientar o ubicar la antena receptora.
- Incrementar la distancia entre el equipo y el receptor.
- Conectar el equipo a una toma de corriente en un circuito distinto del circuito en el cual está conectado el receptor.
- Consultar con el distribuidor o un técnico de radio y TV con experiencia para obtener su ayuda.

¡IMPORTANTE! Todo cambio o modificación no aprobado expresamente por el fabricante podría desautorizar al usuario para operar el equipo.

Industria de Canada

Este dispositivo cumple con las normas de la Industria de Canada licencia-exenta RSS. Su funcionamiento está sujeto a las siguientes dos condiciones: (1) este dispositivo no deberá causar ninguna interferencia dañina, y (2) este dispositivo deberá aceptar cualquier interferencia, incluyendo aquella que podría causar el funcionamiento no deseado del dispositivo.

Regulatory Compliance

This product complies with standards established by the following regulatory bodies:

- Federal Communications Commission (FCC)
- Industry Canada

FCC

This device complies with Part 15 of the FCC Rules. Operation is subject to the following two conditions: (1) this device may not cause harmful interference, and (2) this device must accept any interference received, including interference that may cause undesired operation.

This equipment has been tested and found to comply with the limits for a Class B digital device, pursuant to Part 15 of the FCC Rules. These limits are designed to provide reasonable protection against harmful interference in a residential installation. This equipment generates, uses, and can radiate radio frequency energy and, if not installed and used in accordance with the instructions, may cause harmful interference to radio communications. However, there is no guarantee that interference will not occur in a particular installation. If this equipment does cause harmful interference to radio or television reception, which can be determined by turning the equipment off and on, the user is encouraged to try to correct the interference by one or more of the following measures:

- Reorient or relocate the receiving antenna.
- Increase the separation between the equipment and receiver.
- Connect the equipment into an outlet on a circuit different from that to which the receiver is connected.
- Consult the dealer or an experienced radio/TV technician for help.

IMPORTANT! Changes or modifications not expressly approved by the manufacturer could void the user's authority to operate the equipment.

Industry Canada

This device complies with Industry Canada licence-exempt RSS standard(s). Operation is subject to the following two conditions:

(1) this device may not cause interference, and (2) this device must accept any interference, including interference that may cause undesired operation of the device.

Important Safeguards

1. Read all instructions in their entirety.
2. Familiarize yourself with all warning and caution statements.
3. Remind all family members of safety precautions.
4. Always have access to your lock's standard key.
5. If using the Triple Touch Lock feature, make sure to have your smartphone, fob or standard key with you to prevent locking yourself out.
6. Familiarize yourself with all light ring error notifications.
7. Replace low batteries immediately.

Preventing Inadvertent Unlocking of Your Door

⚠ WARNING: Failure to follow these safeguards could result in your lock opening inadvertently.

1. Avoid keeping and storing phones and fobs unnecessarily close to the lock when inside the home.
2. Restrict access to your Kevo lock's back panel and routinely check your settings to ensure they have not been altered without your knowledge.
3. Protect the password to your Kevo app and web portal accounts.
4. When sending an eKey, always double-check that you are sending it to the correct recipient.
5. Protect and restrict access to your smartphone so that your app settings cannot be altered without your knowledge.
6. Enable the Kevo app's security passcode so that your app settings cannot be altered without your knowledge.
7. When sending eKeys, be aware of the difference between an Admin user and other users in the system: an Admin user can send, disable and delete eKeys.
8. If your smartphone is lost or stolen, use the Kevo web portal (www.mykevo.com) to disable it.
9. If a fob in your Kevo system is lost or stolen, reset your lock to delete it from memory.

⚠ CAUTION: As with any radio-based technology, it should be noted that the accuracy and reliability of the Kevo lock's inside-outside sensor cannot be guaranteed. Users should not rely solely on the Kevo lock's sensor for security purposes and should always use caution. This manufacturer assumes no responsibility for incorrect results or damages resulting from the use of the Kevo lock's sensor.

Certain home configurations may impede the Kevo lock's sensor more than others. Example: *Your home office is located next to your entryway, and part of the office extends past the front door, jutting into the front yard. If your device is being actively used in that office extension, the Kevo lock's sensor could possibly detect the device as being outside of your home while that device is in active use.*

⚠ WARNING: This Manufacturer advises that no lock can provide complete security by itself. This lock may be defeated by forcible or technical means, or evaded by entry elsewhere on the property. No lock can substitute for caution, awareness of your environment, and common sense. Builder's hardware is available in multiple performance grades to suit the application. In order to enhance security and reduce risk, you should consult a qualified locksmith or other security professional.

Medidas de protección importantes

1. Lea las instrucciones en su totalidad.
2. Familiarícese con todas las definiciones de advertencia y precaución.
3. Recuerde a todos los integrantes de su familia las precauciones de seguridad.
4. Siempre tenga acceso a la llave estándar de su cerradura.
5. Si utiliza la función de cierre con tres toques, verifique que lleve consigo el teléfono inteligente, llavero transmisor o llave estándar para evitar quedarse afuera.
6. Familiarícese con todas las notificaciones de error que aparecen con anillo de luz.
7. Cambie las baterías gastadas de inmediato.

Impedir la apertura involuntaria de la puerta

⚠ ADVERTENCIA: Si no se cumplen estas medidas de protección, la cerradura podría abrirse involuntariamente.

1. Evite mantener y guardar los teléfonos y llaveros transmisores cerca de la cerradura cuando esté en el interior de la casa.
2. Limite el acceso al panel posterior de la cerradura Kevo y verifique en forma rutinaria las configuraciones para comprobar que no hayan sido alteradas sin su conocimiento.
3. Proteja las contraseñas de las cuentas del portal web y aplicación Kevo.
4. Al enviar una llave electrónica, siempre vuelva a comprobar que la está enviando al destinatario correcto.
5. Proteja y limite el acceso a su teléfono inteligente para que no se puedan alterar las configuraciones de la aplicación sin su conocimiento.
6. Habilite el código de acceso de seguridad de la aplicación Kevo para que no se puedan alterar las configuraciones de la aplicación sin su conocimiento.
7. Al enviar llaves electrónicas, tenga en cuenta la diferencia entre un usuario Admin y otros usuarios del sistema: el usuario Admin puede enviar, deshabilitar y eliminar llaves electrónicas.
8. Si pierde o roban su teléfono inteligente, utilice el portal web (www.mykevo.com) para deshabilitar el dispositivo inteligente.
9. Si pierde o roban su llavero transmisor, reinicie la cerradura para eliminarla de la memoria.

⚠ PRECAUCIÓN: Al igual que con cualquier tecnología de radio, se debe tener en cuenta que la precisión, la confiabilidad o la utilidad del posicionamiento de su dispositivo no se pueden garantizar con ubicaciones derivadas del sensor correspondiente a la cerradura Kevo; esta función se brinda solo por propósitos de comodidad. Los usuarios no deben confiar únicamente en el sensor de la cerradura Kevo para propósitos de seguridad y siempre deben tener precaución. Kwikset no asume responsabilidad alguna por resultados incorrectos o daños producidos por el uso del sensor de la cerradura Kevo.

Ciertas configuraciones domésticas pueden impedir el funcionamiento del sensor de la cerradura Kevo más que otras. Ejemplo: *Su oficina está ubicada junto al recibidor, y parte de la oficina se extiende más allá de la puerta principal, proyectándose hacia el patio principal. Si su dispositivo se utiliza en forma activa en dicha extensión de la oficina, es posible que el sensor de la cerradura Kevo detecte el dispositivo en una ubicación externa al hogar mientras dicho dispositivo se encuentra en uso activo.*

⚠ ADVERTENCIA: Este Fabricante hace saber que no hay cerrojos que puedan proporcionar completa seguridad por sí mismos. Puede hacerse que falle este cerrojo forzándolo o utilizando medios técnicos, o puede evadirse entrando por otra parte de la propiedad. No hay cerrojos que puedan hacer de sustitutos para la precaución, el estar al tanto del entorno, y el sentido común. Pueden obtenerse piezas de ferretería de constructor con diversos grados de rendimiento para ajustarse a la aplicación. Para realizar la seguridad y reducir los riesgos, debe consultar con un cerrajero capacitado o otro profesional de seguridad.

Mesures de protection importantes

1. Lire toutes les instructions en entier.
2. Familiarisez-vous avec tous les avertissements et mises en garde.
3. Rappelez les précautions de sécurité à tous les membres de la famille.
4. Conservez un accès permanent à la clé standard de votre serrure.
5. Lors de l'utilisation de la fonction trois touches de la serrure, assurez-vous d'avoir avec vous votre téléphone intelligent, porte-clés électronique ou clé standard pour éviter que la porte ne se verrouille alors que vous êtes dehors.
6. Familiarisez-vous avec tous les anneaux lumineux de notification d'erreur.
7. Remplacez les piles faibles immédiatement.

Empêcher le déverrouillage involontaire de votre porte

⚠ WARNING: Failure to follow these safeguards could result in your lock opening inadvertently.

1. Évitez de garder ou entreposer des porte-clés électroniques et téléphones excessivement près de la serrure lorsque vous êtes à l'intérieur de la maison.
2. Restreignez l'accès au panneau arrière de votre serrure Kevo et vérifiez régulièrement vos réglages pour vous assurer qu'ils n'ont pas été modifiés à votre insu.
3. Protégez les mots de passe de vos comptes de portail Web et application Kevo.
4. Lors de l'envoi d'une eKey, revérifiez systématiquement que vous êtes en train de l'envoyer au bon destinataire.
5. Protégez et restreignez l'accès à votre téléphone intelligent afin que les réglages de votre application ne puissent être modifiés à votre insu.
6. Activez le code d'accès de sécurité de l'application Kevo afin que les réglages de votre application ne puissent être modifiés à votre insu.
7. Lors de l'envoi d'eKeys, tenez compte de la différence entre un utilisateur Administrateur et d'autres utilisateurs du système ; un utilisateur Administrateur peut envoyer, désactiver et supprimer des eKeys.
8. Si votre téléphone est perdu ou volé, utilisez le portail Web (www.mykevo.com) pour le supprimer ou le désactiver.
9. Si votre porte-clés électronique est perdu ou volé, réinitialisez votre serrure pour l'effacer de la mémoire.

⚠ ATTENTION: Comme pour une technologie radio, il est à noter que la précision, la fiabilité ou l'utilisabilité du positionnement de votre appareil indiqué par le capteur intérieur-extérieur de la serrure Kevo ne peuvent être garanties; ces données sont fournies à titre de commodité uniquement. Les utilisateurs ne doivent pas se fier exclusivement aux capteurs de la serrure Kevo à des fins de sécurité et ils doivent toujours faire preuve de prudence. Le fabricant se dégage de toute responsabilité en cas de résultats incorrects ou de dommages découlant de l'utilisation du capteur de la serrure Kevo.

Certaines configurations de maisons peuvent entraver plus que d'autres le capteur de la serrure Kevo. Exemple: *Votre bureau à la maison est situé à côté de votre entrée, et une partie du bureau s'étend au-delà de la porte de la façade, s'avancant sur la cour d'entrée. Si votre appareil est en train d'être utilisé activement dans cette extension de bureau, le capteur de la serrure Kevo pourrait éventuellement détecter l'appareil comme étant à l'extérieur de votre maison alors que cet appareil est en utilisation active.*

⚠ AVERTISSEMENT: Le fabricant tient à vous aviser qu'aucun verrou ne peut à lui seul offrir une sécurité complète. Ce verrou peut être mis hors d'état par la force ou des moyens techniques ou être évité par l'utilisation d'une autre entrée dans la propriété. Aucun verrou ne peut remplacer la surveillance de votre environnement et le bon sens. Différentes qualités de matériel d'installation sont offertes pour différentes applications. Afin d'augmenter la sécurité et de réduire le risque, vous devriez consulter un serrurier qualifié ou un autre professionnel de la sécurité.