

INSTRUCTIONS

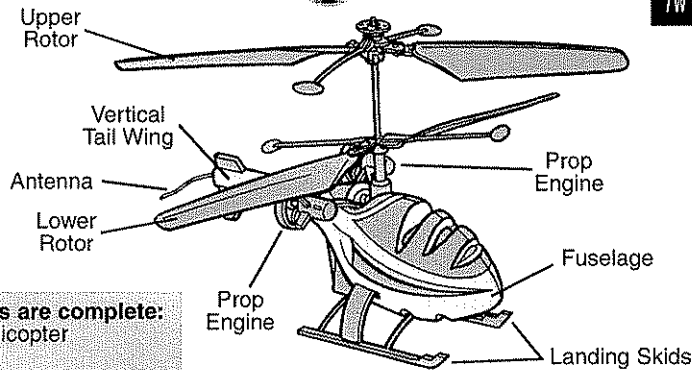
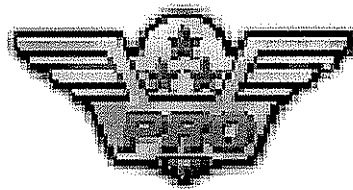

Helicopter

CAUTION - ELECTRICALLY OPERATED PRODUCT:
Not recommended for children under 10 years of age. As with all electric products, precautions should be observed during handling and use to prevent electric shock. INPUT : AC 120V 60HZ
7W OUTPUT ; DC 5.5V 280MA.

PLEASE READ THESE INSTRUCTION BEFORE FLYING! ADULT SUPERVISION RECOMMENDED.

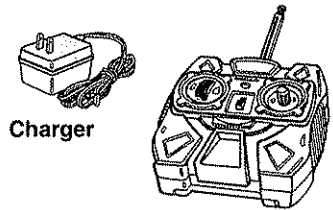

Charger

Controller

Check to make sure contents are complete:

- 1 Air Hogs® Helix™ Micro Helicopter
- 1 Controller • 1 Charger
- 1 9-Volt Heavy Duty Battery
- 4 Spare Rotors • 1 Instructions Manual

HELICOPTER BATTERY INFORMATION

- Charge the Air Hogs® Helix™ battery only with the provided Air Hogs® Lithium Polymer Charger.
- Charging operation should be performed by adults only.
- The Helix™ battery is only partially charged. Fully charge the Helix™ battery pack before its first flight.
- Always fully charge the Helix™ battery pack in repeat use.
- The supply terminals are not to be short-circuited.
- Do not attempt to open the LiPo battery pack.
- Stop using and do not recharge the LiPo battery pack if it shows leakage, damage or deformation.
- Do not allow the Helix™ to get wet.
- Always store the Helix™ in a cool and dry place.
- Dispose of Helix™ properly and never dispose of it in fire.
- Do not recharge the Helix™ battery pack immediately after use. Wait until it is cool before charging.
- Be sure the wall charger and Helix™ are kept out of the hands of infants and small children.
- Do not charge near fire, where temperature is extremely high, or when it is wet or damp.
- Do not continue to charge the Helix™ if the charger fails to recognize full charge.
- Overheating or swelling of the LiPo cells is an indicator that they are in an over charged condition and the batteries should be disconnected from the charger immediately!!
- Do not allow the LiPo battery pack to overheat at any time. Cells which reach greater than 140°F (60°C) can and USUALLY WILL become damaged physically and could possibly catch FIRE! Always inspect a battery which has previously overheated for potential damage and DO NOT reuse it if you suspect it has been damaged in any way.
- Do not allow LiPo batteries to be charged or discharged on or near combustible materials, including paper, plastics, carpets, vinyl, leather, wood, inside an R/V or full-sized automobile!
- Always provide adequate ventilation around LiPo batteries during charge, discharge, while in use and during storage. If a battery becomes overheated, remove it from the charger IMMEDIATELY and place it in a fire-proof location until it cools.
- Do not modify the Helix™ battery pack in any way which might result in permanent damage or dangerous responses.
- Immediately remove a LiPo battery from a model if it is involved in a crash in anyway. Do not use a LiPo battery if you suspect physical damage has occurred to the pack. Carefully inspect the battery for even the smallest of dents, cracks, splits, punctures or damage. A LiPo battery might not appear to be damaged after a crash, but it could smolder over a short amount of time and suddenly catch fire unexpectedly, if in doubt, place the battery in a fire-proof location indefinitely.

ADULTS NOTE: Adult supervision required. Periodically examine this product for damage to the cord, housing or other parts that may result in the risk of fire, electric shock or injury. If the product is damaged, do not use it.

CONTROLLER BATTERY INSTALLATION

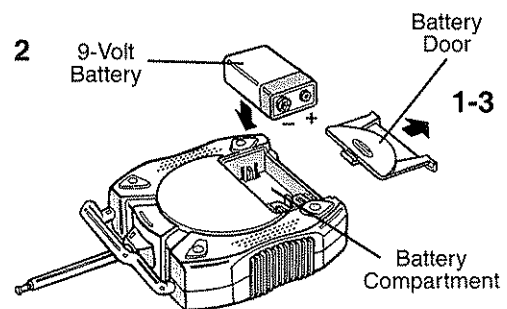

NOTE: 9-Volt heavy duty battery included "For demonstration purposes only".

1. Remove the battery door.
2. Install a **9-Volt alkaline battery** in the battery compartment. Be careful to align the positive (+) and negative (-) polarities with the corresponding markings inside the battery compartment.
3. Reinstall the battery compartment door.

CONTROLLER BATTERY INFORMATION

- Battery installation should be performed by an adult.
- Use only batteries recommended on the package and in the instruction manual.
- Be careful to install the batteries with the correct polarity, as indicated.
- Do not mix old and new batteries.
- Do not mix alkaline, standard or rechargeable, or different types of batteries.
- Non-rechargeable batteries are not to be recharged.
- Rechargeable batteries are to be removed from the toy before being charged (if removable).
- Rechargeable batteries are only to be charged under adult supervision (if removable).
- Only batteries of the same or equivalent type as recommended are to be used.
- The supply terminals are not to be short-circuited.
- Exhausted batteries are to be removed from the toy, as they will adversely affect the performance.

CHARGING YOUR HELIX™ HELICOPTER

1. Make sure that your Helix™ helicopter's "ON/OFF" switch is in the "OFF" position.
2. Plug the charger into a wall outlet.
3. Connect the "charge cable" to the Helix™ charging port. Make sure cable plug aligns with charging port. When charging, a red LED light on the helicopter will flash and when the charging is completed, the light will turn "OFF".

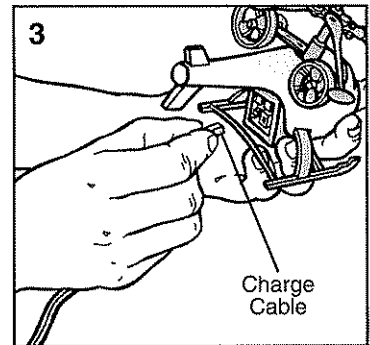
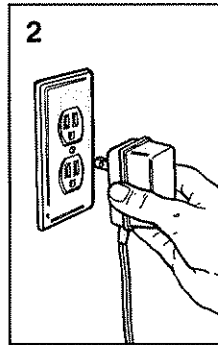
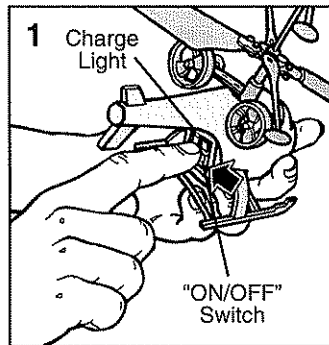

FLIGHT PREPARATION

1. Extend the controller antenna fully.
2. Turn the Helix™ helicopter "ON/OFF" switch to the "ON" position.
3. Push the controller switch to the "ON" position.

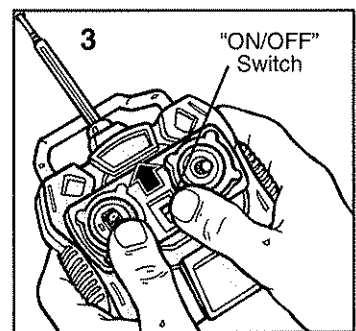
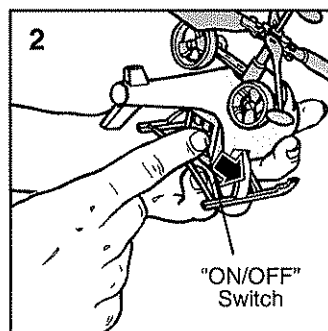
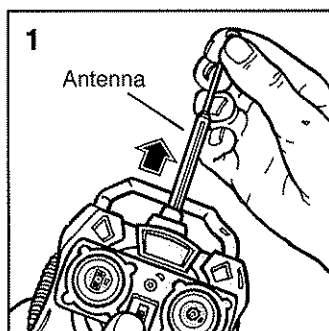

IMPORTANT: HELICOPTER ROTORS MUST BE TRIMMED CORRECTLY BEFORE FLYING!

- In order to fly your Helix™ properly, you must first correctly trim the rotors. The trim wheel is located at the top of the rotors.
- Turn the helicopter and controller on. Increase the throttle slowly until the Helix™ takes off. (You want to fly the helicopter low)

1. Location of adjustable trim wheel above rotors
2. Slowly push on the throttle until the Helix™ takes off from the ground.
3. If the helicopter is spinning counter clockwise, turn the wheel a little bit clockwise.
4. If the helicopter is spinning clockwise, turn the wheel a little bit COUNTER clockwise.

When properly trimmed, the helicopter will not spin, it may drift on take-off but the body should not spin independent of the directional control. It may take a few tries to find the right trim.

Once you have your Helix™ trimmed correctly, you are ready to fly. For the first flight, pick a pretty wide open space indoors.

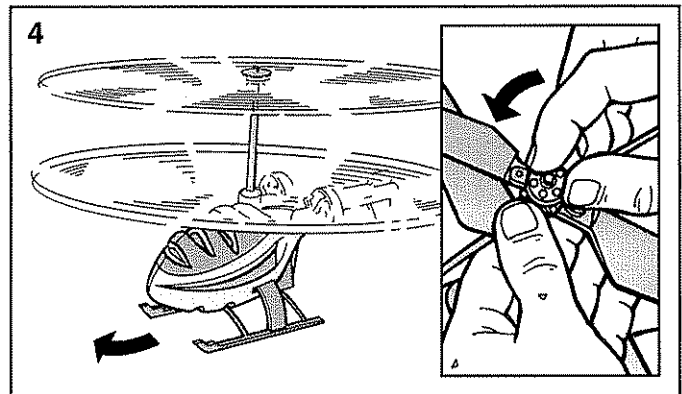
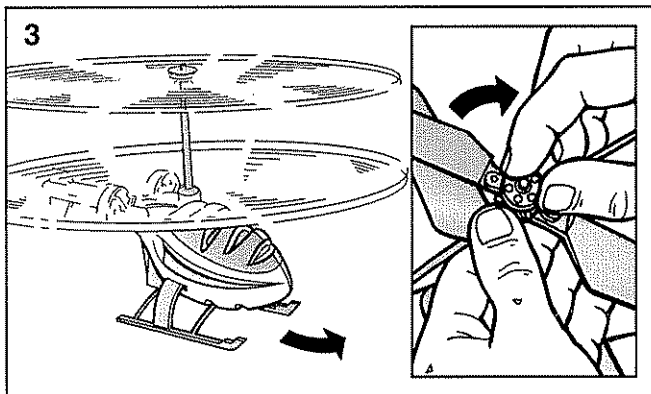
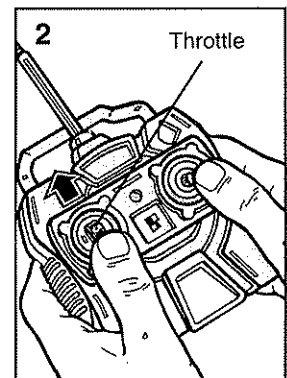
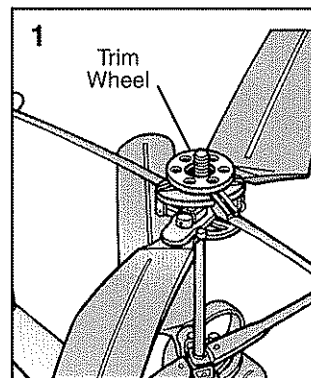

Practice! Flying a helicopter is a skill that takes time to acquire!

HOVERING YOUR HELIX™ HELICOPTER

1. Slowly push on the throttle until the helicopter takes off from the ground.
2. The helicopter will always hover slowly forward and in a bit of a turn either right or left.

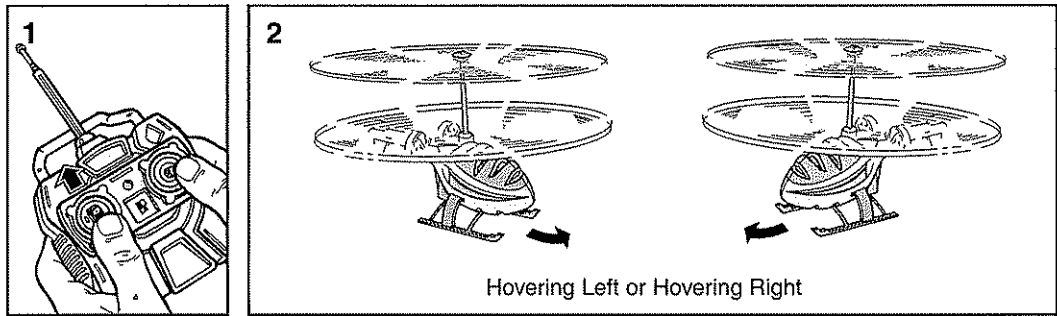

FLYING YOUR HELIX™ HELICOPTER

IMPORTANT: TO BEST FLY THE HELICOPTER, DIRECTIONAL INPUTS NEED TO BE SPACED OUT AND ACTIVATED WHEN THE HELICOPTER IS FLYING RELATIVELY STABLE. CRAMMING DIRECTIONAL INPUTS OR TRYING TO COMPLETELY CHANGE DIRECTIONS IN A HARSH MOVE WILL DE-STABILIZE THE HELICOPTER'S FLIGHT PATTERN.

Slowly apply the throttle until the helicopter takes off from the ground. Once it is in flight, increase or decrease the throttle slowly to get to a clear flying altitude.

Once you have tentatively set your altitude, let helicopter float around the room and center itself before giving any directional inputs.

The helicopter will always hover slowly forward and in a bit of a turn. Learn how the helicopter tends to fly and controlling it will be much easier.

NOTE: When direction inputs (Forward/Back, Right/Left) are applied, the helicopter will lose some altitude. You can compensate for this with small increases to the throttle.

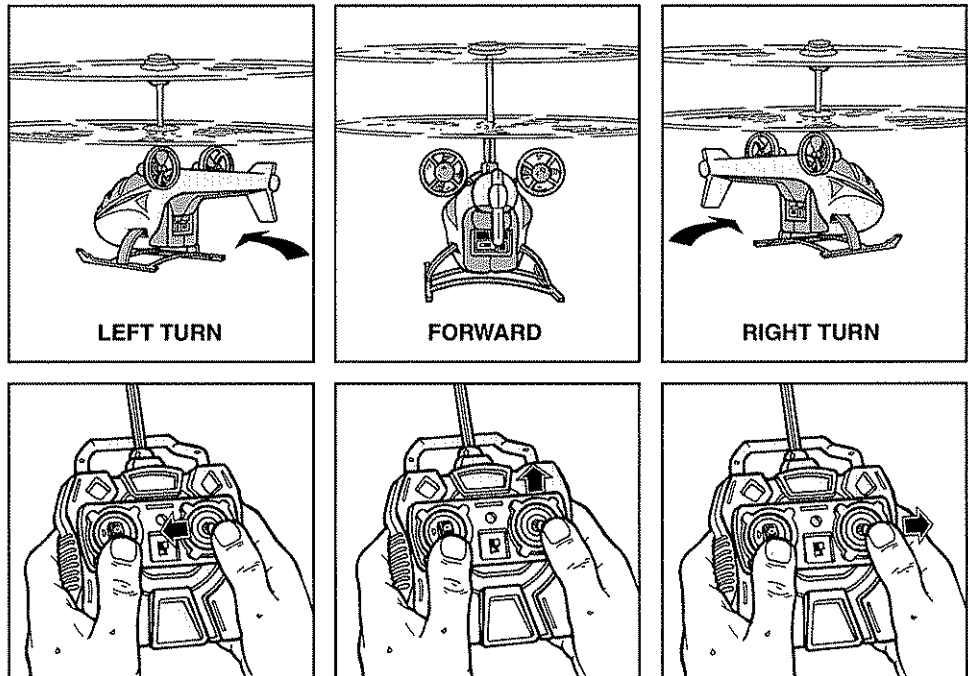

LANDING YOUR HELIX™ HELICOPTER

- When flying the helicopter near obstacles, always land it when it seems like it is going to hit something.
- To land the helicopter, reduce throttle slowly. A fast reduction in throttle will crash the unit.

WHEN FINISHED FLYING

1. When finished flying the helicopter, turn the "ON/OFF" switch on the helicopter to the "OFF" position.
2. Turn the "ON/OFF" switch on the controller to the "OFF" position.
3. Then push the controller antenna in to its stored position.

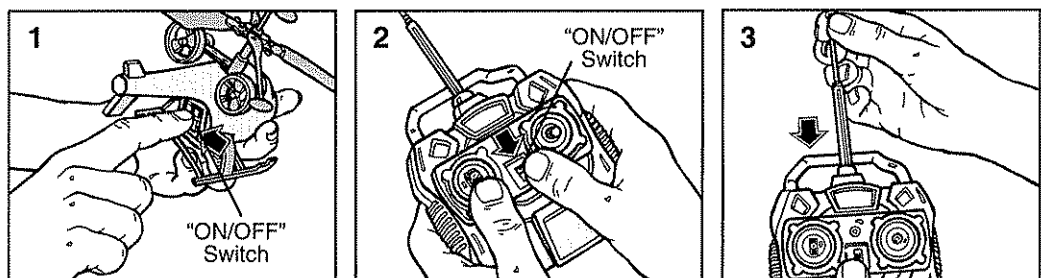

REPAIRS

The Helix™ helicopter is equipped with folding rotors to prevent damage when the helicopter lands. Reset the rotor positions as shown.

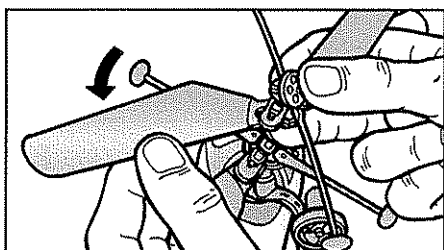

Clear tape can be used to repair the helicopter fuselage.

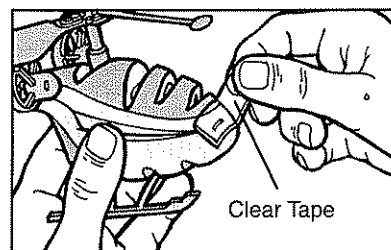

OTHER CARE AND HANDLING INSTRUCTIONS

- NEVER leave the Helix™ unattended at any time while being charged or discharged.
- The charger will become slightly heated while charging. Allow sufficient free space around the charger.
- If the power of the battery pack is weak in spite of proper charging, the LiPo battery may have been worn out from repeated use.
- ALWAYS store the Helix™ in a secure location away from small children.

PRE-FLIGHT ENVIRONMENT CHECK

Flying Indoors?

Location – Fly in a wide-open room, far away from breakable items. An empty double car garage or unfinished basement are great options. Avoid flying near vents and/or fans, as these may overpower the helicopter and make it difficult to control.

NOTE: Always get a parent's permission to fly your Helix™ indoors.

Flying Outdoors?

1. **Location** – Fly in a wide open grassy location that it is free of buildings, trees, overhead wires and other obstructions. Do not fly near people or animals.
2. **Weather** – Fly on mild, sunny days. Do not fly in electrical storms, rain, sleet, snow or other adverse weather conditions. Do not fly if the temperature is below 45°F/7°C. In very cold temperatures, the helicopter will become fragile and the engine performance will decrease.
3. **Wind Conditions** – Do not fly in wind. Winds may overpower the helicopter and make it difficult to control. In windy conditions, it may appear as though you have no control over the helicopter.

WARNING: Never fly near your face. Keep rotors away from your fingers, hair, eyes and other body parts. Always lift off from a flat surface. Never hold the helicopter in your hand when lifting OFF. Always store the helicopter in its original container to avoid bending the rotors.

NOTE: Regardless whether you're flying indoors or outside, make sure that the batteries are in working order.

TROUBLESHOOTING

PROBLEM	SOLUTION
Helicopter does not turn ON.	Turn power OFF on helicopter and controller for 10 seconds, (Helix™ may need to be re-set after crashes) then turn ON.
Re-charge.	When charging, a red LED light should start flashing. When the light goes out, the helicopter is charged. Helix™ is equipped with LiPo low voltage detection to protect the battery, but users should always turn OFF and re-charge when power is drained enough to adversely affect performance.
Helicopter spins out of control.	Helicopter rotors must be trimmed properly. See previous section – "IMPORTANT: HELICOPTER ROTORS MUST BE TRIMMED CORRECTLY BEFORE FLYING!"
Rotor is bent or broken.	The plastic rotors can be bent back to shape, and broken ones can even be taped back together.
Damaged fuselage.	Just tape back in place with clear tape.



WARNING: Lithium Polymer (LiPo) batteries are very different from other types of batteries and must be handled and disposed of properly. Please refer to and read the included care and handling instructions for this part.

FCC REQUIREMENTS

This device complies with part 15 of the FCC Rules. Operation is subject to the following two conditions:

- 1) This device may not cause harmful interference.
 - 2) This device must accept any interference received, including interference that may cause undesired operation.
- WARNING:** Changes or modifications not expressly approved by the party responsible for its compliance could void the user's authority to operate the equipment.

Spin Master Ltd., 450 Front Street West, Toronto, ON M5V 1B6 Canada
 Spin Master, Inc., PMB #10053, 300 International Drive, Suite 100,
 Williamsville, NY 14221, USA
 Spin Master Toys Far East Limited, Rm #1113, 11/F,
 Chinachem Golden Plaza, 77 Mody Rd., Tsimshatsui E., Kowloon, HK

TM and © 2006 Spin Master Ltd. Air Hogs® is a registered trademark of Spin Master Ltd. All rights reserved. Conforms to product safety standards ASTM F963-03, regulatory requirements. Products and colors may vary. Please retain this information for future reference. Patent Pending.
 MADE IN CHINA.

Contains LiPo battery pack. Battery pack must be recycled or disposed of properly.



North American Consumer Information
 Phone: 1-800-622-8339
 www.spinmaster.com

Asst. #44164
 #20003844

44164-ENG-IS-3
 REV 3 US English

Asst. #44164



NOTE: This equipment has been tested and found to comply with the limits for a Class B digital device, pursuant to Part 15 of the FCC Rules. These limits are designed to provide reasonable protection against harmful interference in a residential installation. This equipment generates, uses, and can radiate radio frequency energy and, if not installed and used in accordance with the instructions, may cause harmful interference to radio communications. However, there is no guarantee that interference will not occur in a particular installation. If this equipment does cause harmful interference to radio or television reception, which can be determined by turning the equipment off and on, the user is encouraged to try to correct the interference by one or more of the following measures:

- Reorient or relocate the receiving antenna.
- Increase the separation between the equipment and receiver.
- Connect the equipment into an outlet on a circuit different from that to which the receiver is connected.
- Consult the dealer or an experienced radio TV technician for help.