

10+

Years/Ans/Años  
Jahre/Jaar/Anni  
Anos/Лет

## MECCANOID G15 PERSONAL ROBOT



- INSTRUCTION GUIDE
- MODE D'EMPLOI
- GUÍA DE INSTRUCCIONES
- BEDIENUNGSANLEITUNG
- GEBRUIKSAANWIJZING
- GUIDA PER L'USO
- GUIA DE INSTRUÇÕES
- ИНСТРУКЦИЯ ПО ИСПОЛЬЗОВАНИЮ

For instructions in other languages, visit [www.meccano.com](http://www.meccano.com)

Pour télécharger les instructions dans une autre langue, rends-toi sur [www.meccano.com](http://www.meccano.com)

Para consultar las instrucciones en otros idiomas, visita [www.meccano.com](http://www.meccano.com)

Eine detaillierte Bedienungsanleitung in deutscher Sprache findest du auf [www.meccano.com](http://www.meccano.com).

Voor instructies in andere talen, bezoek [www.meccano.com](http://www.meccano.com)

Per le istruzioni in altre lingue, visitare il sito [www.meccano.com](http://www.meccano.com)

Para instruções em outros idiomas, acesse [www.meccano.com](http://www.meccano.com)

Инструкции на других языках можно найти на сайте [www.meccano.com](http://www.meccano.com)

⚠ **WARNING:** Cords could be a strangulation hazard. Not for use by children under 3 years of age.

⚠ **ATTENTION!** Les câbles peuvent présenter un risque de strangulation. Ne pas laisser à la portée des enfants de moins de 3 ans.

4x C/LR14 1.5V  
BATTERIES NOT INCLUDED / PILES NON FOURNIES / PILAS NO INCLUIDAS / BATTERIEN NIET ENTHALTEN / BATTERIEN NIET INBEGRIPEN / BATTERIE NON INCLUSE / PILAS NÃO INCLUIDAS / ЭЛЕМЕНТЫ ПИТАНИЯ НЕ ВХОДЯТ В КОМПЛЕКТ



UK – 0800 206 1191, [SERVICEUK@SPINMASTER.COM](mailto:SERVICEUK@SPINMASTER.COM)  
FRANCE – 0800 909 150, [SERVICEFR@SPINMASTER.COM](mailto:SERVICEFR@SPINMASTER.COM)  
ESPAÑA – [SERVICIO@SPINMASTER.COM](mailto:SERVICIO@SPINMASTER.COM)  
DEUTSCHLAND – 00800 0101 0222, [KUNDENSERVICE@SPINMASTER.COM](mailto:KUNDENSERVICE@SPINMASTER.COM)  
SCHWEIZ – 0800 561 350 • ÖSTERREICH – 0800 29 72 67  
NEDERLAND – 0800 022 36 83, [KLANTENSERVICE@SPINMASTER.COM](mailto:KLANTENSERVICE@SPINMASTER.COM)  
BELGIË/BELGIQUE – 0800 77 688 • LUXEMBOURG – 800 28 044  
ITALIA – 800 788 532, [SERVIZIO@SPINMASTER.COM](mailto:SERVIZIO@SPINMASTER.COM)  
MEXICO – 53.51.44.00  
[WWW.SPINMASTER.COM](http://WWW.SPINMASTER.COM)

NORTH AMERICA: 1-800-622-8339 [customer-care@spinmaster.com](mailto:customer-care@spinmaster.com)  
AMÉRIQUE DU NORD:

**FCC Statement:** This device complies with Part 15 of the FCC rules. Operation is subject to the following two conditions: (1) This device may not cause harmful interference, and (2) This device must accept any interference received, including interference that may cause undesired operation. This equipment has been tested and found to comply with the limits for Class B digital devices, pursuant to Part 15 of the FCC rules. These limits are designed to provide reasonable protection against harmful interference to radio communications. This equipment generates, uses and can radiate radio frequency energy and, if not installed and used in accordance with the instruction, may cause harmful interference to radio communication. However, there is no guarantee that interference will not occur in a particular installation. If this toy does cause interference to radio or television reception (you can check this by turning the toy off and on while listening for the interference), one or more of the following measures may be useful: • Reorient or relocate the receiving antenna • Increase the separation between the toy and the radio or the TV • Consult the dealer or an experienced TV-radio technician for help. Shielded cables must be used with this unit to ensure compliance with the Class B FCC limits. Shielded cables must be used with this unit to ensure compliance with the Class B FCC limits. **NOTE:** Changes, adjustments or modifications to this unit, including but not limited to, replacement of any transmitter component (crystal, semiconductor, etc) could result in a violation of FCC rules under part 15 and/or 95 and must be expressly approved by Spin Master Ltd or they could void the user's authority to operate the equipment.

**Déclaration de la FCC :** Le présent appareil est conforme à l'article 15 de la réglementation de la FCC. L'utilisation est autorisée aux deux conditions suivantes : (1) l'appareil ne doit pas produire de brouillage, et (2) l'appareil doit accepter tout brouillage radioélectrique subi, même si le brouillage est susceptible d'en compromettre le fonctionnement. Cet équipement a été testé et jugé conforme aux limites de la classe B pour les équipements numériques en vertu de l'article 15 de la réglementation de la FCC. Ces limites ont été instaurées pour assurer une protection raisonnable contre toute interférence nuisible avec les communications radio. Cet équipement génère, utilise et peut émettre de l'énergie de fréquence radio. S'il n'est pas installé et utilisé selon le mode d'emploi, il peut causer des interférences nuisibles aux communications radio. Cependant, il n'existe aucune garantie contre ces interférences dans le cas où l'installation ne serait pas conforme. Si ce jouet cause des interférences à la réception radio ou télévisée (ce qui est vérifiable en l'éteignant, puis en le rallumant tout en écoutant s'il y a des interférences), suivre une ou plusieurs des recommandations suivantes : • Réorienter ou déplacer l'antenne réceptrice • Augmenter la distance entre le jouet et la radio ou la télévision • Consulter le revendeur ou demander l'aide d'un technicien radio/T.V. expérimenté. Pour respecter les limites de la classe B de la réglementation de la FCC, cet appareil doit être utilisé avec des câbles blindés.

**REMARQUE :** tout changement, réglage ou modification de cet appareil, incluant mais ne se limitant pas au remplacement de tout composant du transmetteur (cristal, semi-conducteur, etc.), pourrait constituer une violation de l'article 15 et/ou 95 de la réglementation de la FCC, et doit être expressément approuvé par Spin Master Ltd., sous peine d'entraîner l'annulation du droit de l'utilisateur d'exploiter l'équipement.

**Declaración de la FCC:** Este dispositivo cumple con la sección 15 de la normativa de la FCC. El funcionamiento está sujeto a estas dos siguientes condiciones: (1) el dispositivo no debe causar interferencias dañinas, y (2) el dispositivo debe admitir la recepción de cualquier tipo de interferencia, incluidas aquellas que puedan causar un funcionamiento indeseado. Este equipo ha sido probado y cumple los límites para dispositivos de clase B digital establecidos en la sección 15 de la normativa de la FCC. Estos límites han sido diseñados para proporcionar una protección razonable contra la interferencia dañina en las comunicaciones por radio. Este equipo genera, utiliza y emite energía en forma de radiofrecuencias, por lo que si no se instala y utiliza como indican las instrucciones, podría provocar interferencias dañinas en comunicaciones de radio. No obstante, no se puede garantizar que no habrá interferencias en una instalación determinada. Si este juguete provoca interferencias en la recepción de radio o televisión (puede comprobarlo apagando y encendiendo el juguete mientras escucha si se producen interferencias), puede tomar alguna de las siguiente medidas: • Reorientar o cambiar de lugar la antena receptora • Aumentar la separación entre el juguete y la radio o el televisor • Consultar con el vendedor o un técnico de televisión y radio si necesita asistencia adicional. Para cumplir con los límites de la clase B de las normas FCC, este aparato se debe utilizar con cables blindados. **NOTA:** Los cambios, los ajustes o las modificaciones realizadas en este dispositivo, como, entre otros, la sustitución de cualquier componente transmisor (cristal, semiconductor, etc.) podría suponer la infracción de las secciones 15 ó 95 de la normativa de la FCC, y debe ser explícitamente aprobada por Spin Master Ltd.; en caso contrario, el usuario podría verse privado del derecho de operar el equipo.

**(GB) Content:** 600 Parts, 1 MeccaBrain™, 1 LED module, 2 hand tools, 4 servos, 2 rear wheel assembly, 2 motor gear box assembly, 1 USB cable

**(F) Contenu :** 600 pièces, 1 MeccaBrain™, 1 module LED, 2 outils, 4 servomoteurs, assemblage 2 roues arrière, assemblage 2 moteurs et engrenages, 1 câble USB

**(E) Contenido:** 600 piezas, 1 MeccaBrain™, 1 módulo LED, 2 herramientas, 4 servos, ensamblaje para 2 ruedas traseras, ensamblaje con 2 motores y caja de engranajes, 1 cable USB

**(D) Inhalt:** 600 Teile, 1 MeccaBrain™, 1 LED-Modul, 2 Handwerkzeuge, 4 Servos, 2 Hinterräder zum Zusammenbauen, 2 Getriebe zum Zusammenbauen, 1 USB-Kabel

**(NL) Inhoud:** 600 onderdelen, 1 MeccaBrain™, 1 LED-module, 2 stuks handgereedschap, 4 servo's, 2 achterwielen, 2 motorkasten, 1 USB-Kabel

**(I) Contenuto:** 600 pezzi, 1 MeccaBrain™, 1 modulo a LED, 2 attrezzi, 4 servomotori, kit con 2 ruote posteriori, kit con 2 motori e cambi di velocità, 1 cavo USB

**(P) Conteúdo:** 600 partes, 1 MeccaBrain™, 1 módulo de LED, 2 ferramentas manuais, 4 servomotores, 2 rodas traseiras, 2 caixas com 2 engrenagens e motor, 1 cabo USB

**(R) В коробке:** 600 деталей, 1 MeccaBrain™, 1 светодиодный модуль, 2 ручных инструмента, 4 сервоприводов, комплект из 2 задних колес, комплект из 2 механизированных коробок передач, 1 USB-кабель

### CAN ICES-3 (B)/NMB-3(B)

**CANADIAN Class B statement:** This device complies with Industry Canada Licence-exempt RSS-210. Operation is subject to the following two conditions: (1) this device may not cause interference, and (2) this device must accept any interference, including interference that may cause undesired operation of the device.

**Déclaration CANADIENNE classe B:** Le présent appareil est conforme au CNR-210 d'Industrie Canada applicable aux appareils radio exempts de licence. L'utilisation est autorisée aux deux conditions suivantes : (1) l'appareil ne doit pas produire de brouillage, et (2) l'appareil doit accepter tout brouillage radioélectrique subi, même si le brouillage est susceptible d'en compromettre le fonctionnement.

Only one model can be built at a time. / Les pièces fournies ne permettent de monter qu'un seul modèle à la fois. / Solo es posible construir un modelo a la vez. / Jeweils nur eins der Modelle baubar.

Er kan maar een model tegelijk worden gebouwd. / Permette di realizzare un solo modello per volta. / Só é possível montar um modelo de cada vez. / Одновременно можно построить только одну модель.

1

ASSEMBLY • ASSEMBLAGE • MONTAJE • ZUSAMMENBAU • MONTAGE • MONTAGGIO • MONTAGEM • СБОРКА

2

CONNECT AND PLUG IN • BRANCHEMENTS ET CONNEXIONS • CONÉCTALO • VERBINDEN UND ANSCHLIESSEN • AANSLUITEN  
COLLEGAMENTI • CONECTE • ПОДКЛЮЧЕНИЕ И УСТАНОВКА

3

PLAY • JEU • CÓMO JUGAR • SPIELEN • SPELEN • GIOCO • COMO JOGAR • ВОСПРОИЗВЕДЕНИЕ

# TABLE OF CONTENTS • SOMMAIRE • ÍNDICE • INHALTSVERZEICHNIS • INHOUD • INDICE • СОДЕРЖАНИЕ

















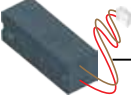
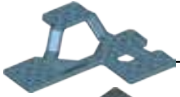
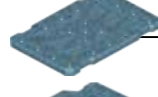





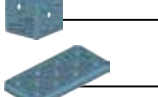







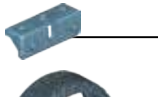

1. ASSEMBLY .....	5-29
1.1 BUILD YOUR ROBOT.....	7-29
2. CONNECT AND PLUG IN .....	30
2.1 PLUG IN AND DOWNLOAD YOUR LANGUAGE. ....	30
2.2 CONNECT THE ELECTRONICS .....	31
3. PLAY .....	32
3.1 LET'S PLAY.....	32
3.2 COMMAND CARD .....	33
3.3 VOICE COMMANDS .....	34
3.4 PROGRAM WITH APP .....	35
CONSUMER INFORMATION .....	41-44









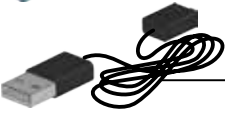

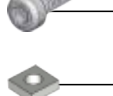

1. ASSEMBLAGE.....	5-29
1.1 MONTAGE DU ROBOT .....	7-29
2. BRANCHEMENTS ET CONNEXIONS .....	30
2.1 BRANCHEMENTS ET TÉLÉCHARGEMENT DE LA LANGUE. ....	30
2.2 RÉALISATION DES BRANCHEMENTS .....	36
3. JEU.....	37
3.1 JOUONS! .....	37
3.2 LISTE DES COMMANDES.....	38
3.3 COMMANDES VOCALES .....	39
3.4 PROGRAMMATION VIA L'APPLICATION.....	40
INFORMATIONS DESTINÉES AU CONSOMMATEUR.....	41-44

1. MONTAJE • ZUSAMMENBAU • MONTAGE • MONTAGGIO • MONTAGEM • СБОРКА .....	5-29
1.1 MONTA TU ROBOT • BAUE DEINEN ROBOTER ZUSAMMEN • BOUW JE EIGEN ROBOT • COSTRUISCI IL TUO ROBOT • MONTE SEU ROBÔ • СБОРКА РОБОТА .....	7-29
2. CONÉCTALO • VERBINDEN UND ANSCHLIESSEN • AANSLUITEN • COLLEGAMENTI • CONECTE • ПОДКЛЮЧЕНИЕ И УСТАНОВКА.....	30
2.1 CONÉCTALO Y DESCARGA TU IDIOMA • ANSCHLIESSEN UND DEINE SPRACHE HERUNTERLADEN • SLUIT AAN EN DOWNLOAD JE TAAL • COLLEGA E SCARICA LA TUA LINGUA • CONECTE E BAIXE SEU IDIOMA ПОДКЛЮЧЕНИЕ И ЗАГРУЗКА ЯЗЫКА.....	30
2.2 CONECTA LOS COMPONENTES ELECTRÓNICOS • ELEKTRONISCHE TEILE VERBINDEN • SLUIT DE ELEKTRONICA AAN • COLLEGA I COMPONENTI ELETTRONICI • CONECTE OS ELETRÔNICOS ПОДКЛЮЧЕНИЕ ЭЛЕКТРОННЫХ КОМПОНЕНТОВ .....	Puedes consultar las instrucciones en tu idioma en <a href="http://www.meccano.com">www.meccano.com</a> • Eine Bedienungsanleitung in deiner Sprache findest du unter <a href="http://www.meccano.com">www.meccano.com</a> • Ga verder met instructies in je eigen taal op <a href="http://www.meccano.com">www.meccano.com</a> • Continua con le istruzioni nella tua lingua su <a href="http://www.meccano.com">www.meccano.com</a> • Continue a ler as instruções em seu idioma acessando <a href="http://www.meccano.com">www.meccano.com</a> • Найдти инструкции на вашем языке можно на сайте <a href="http://www.meccano.com">www.meccano.com</a>
3. CÓMO JUGAR • SPIELEN • SPELEN • GIOCO • COMO JOGAR • ВОСПРОИЗВЕДЕНИЕ.....	Puedes consultar las instrucciones en tu idioma en <a href="http://www.meccano.com">www.meccano.com</a> • Eine Bedienungsanleitung in deiner Sprache findest du unter <a href="http://www.meccano.com">www.meccano.com</a> • Ga verder met instructies in je eigen taal op <a href="http://www.meccano.com">www.meccano.com</a> • Continua con le istruzioni nella tua lingua su <a href="http://www.meccano.com">www.meccano.com</a> • Continue a ler as instruções em seu idioma acessando <a href="http://www.meccano.com">www.meccano.com</a> • Найдти инструкции на вашем языке можно на сайте <a href="http://www.meccano.com">www.meccano.com</a>
3.1 VAMOS A JUGAR • SO WIRD GESPIELT • LATEN WE SPELEN • COMINCIAMO • VAMOS BRINCAR • ДАВАЙ ПОИГРАЕМ .....	Puedes consultar las instrucciones en tu idioma en <a href="http://www.meccano.com">www.meccano.com</a> • Eine Bedienungsanleitung in deiner Sprache findest du unter <a href="http://www.meccano.com">www.meccano.com</a> • Ga verder met instructies in je eigen taal op <a href="http://www.meccano.com">www.meccano.com</a> • Continua con le istruzioni nella tua lingua su <a href="http://www.meccano.com">www.meccano.com</a> • Continue a ler as instruções em seu idioma acessando <a href="http://www.meccano.com">www.meccano.com</a> • Найдти инструкции на вашем языке можно на сайте <a href="http://www.meccano.com">www.meccano.com</a>
3.2 TARJETA DE COMANDOS • BEFEHLSKARTE • COMMANDO-KAART • SCHEDE DEI COMANDI • CARTÃO DE COMANDO • КАРТА КОМАНД .....	Puedes consultar las instrucciones en tu idioma en <a href="http://www.meccano.com">www.meccano.com</a> • Eine Bedienungsanleitung in deiner Sprache findest du unter <a href="http://www.meccano.com">www.meccano.com</a> • Ga verder met instructies in je eigen taal op <a href="http://www.meccano.com">www.meccano.com</a> • Continua con le istruzioni nella tua lingua su <a href="http://www.meccano.com">www.meccano.com</a> • Continue a ler as instruções em seu idioma acessando <a href="http://www.meccano.com">www.meccano.com</a> • Найдти инструкции на вашем языке можно на сайте <a href="http://www.meccano.com">www.meccano.com</a>
3.3 COMANDOS DE VOZ • SPRACHBEFEHLE • SPRAAKOPDRACHTEN • COMANDI VOCALI • COMANDOS DE VOZ • ГОЛОСОВЫЕ КОМАНДЫ .....	Puedes consultar las instrucciones en tu idioma en <a href="http://www.meccano.com">www.meccano.com</a> • Eine Bedienungsanleitung in deiner Sprache findest du unter <a href="http://www.meccano.com">www.meccano.com</a> • Ga verder met instructies in je eigen taal op <a href="http://www.meccano.com">www.meccano.com</a> • Continua con le istruzioni nella tua lingua su <a href="http://www.meccano.com">www.meccano.com</a> • Continue a ler as instruções em seu idioma acessando <a href="http://www.meccano.com">www.meccano.com</a> • Найдти инструкции на вашем языке можно на сайте <a href="http://www.meccano.com">www.meccano.com</a>
3.4 PROGRAMAR CON APLICACIÓN • ÜBER DIE APP PROGRAMMIEREN • PROGRAMMEERBAAR VIA APP • PROGRAMMA CON L'APP • PROGRAME COM O APLICATIVO ПРОГРАММИРОВАНИЕ С ПОМОЩЬЮ ПРИЛОЖЕНИЯ.....	Puedes consultar las instrucciones en tu idioma en <a href="http://www.meccano.com">www.meccano.com</a> • Eine Bedienungsanleitung in deiner Sprache findest du unter <a href="http://www.meccano.com">www.meccano.com</a> • Ga verder met instructies in je eigen taal op <a href="http://www.meccano.com">www.meccano.com</a> • Continua con le istruzioni nella tua lingua su <a href="http://www.meccano.com">www.meccano.com</a> • Continue a ler as instruções em seu idioma acessando <a href="http://www.meccano.com">www.meccano.com</a> • Найдти инструкции на вашем языке можно на сайте <a href="http://www.meccano.com">www.meccano.com</a>
INFORMACION PARA EL CONSUMIDOR • VERBRAUCHERHINWEISE INFORMATIE VOOR GEBRUIKERS • INFORMAZIONI PER I CONSUMATORI • INFORMAÇÕES PARA O CONSUMIDOR • ИНФОРМАЦИЯ ДЛЯ ПОТРЕБИТЕЛЕЙ.....	41-44

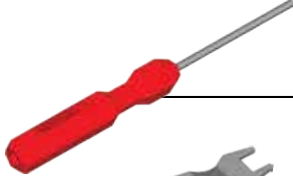

# ASSEMBLY • ASSEMBLAGE • MONTAJE • ZUSAMMENBAU • MONTAGE • MONTAGGIO • MONTAGEM • СБОРКА

	<b>M102 x1</b>		<b>M904 x1</b>		<b>M218 x8</b>
	<b>M902 x4</b>		<b>M019 x3</b>		<b>M018 x1</b>
	<b>M045 x1</b>		<b>M119 x3</b>		<b>M004 x3</b>
	<b>M045 x1</b>		<b>M026 x2</b>		<b>M002 x4</b>
	<b>M016 x4</b>		<b>M026 x4</b>		<b>M010 x4</b>
	<b>M006 x4</b>		<b>M020 x1</b>		<b>M005 x2</b>
	<b>M905 x1</b>		<b>M009 x2</b>		<b>M003 x6</b>
	<b>M013 x1</b>		<b>M215 x1</b>		<b>M001 x20</b>
	<b>M101 x4</b>		<b>M027 x6</b>		<b>M213 x2</b>
	<b>M100 x4</b>		<b>M025 x10</b>		<b>M007 x2</b>
			<b>M031 x2</b>		<b>M021 x2</b>
			<b>M212 x2</b>		<b>M029 x8</b>
			<b>M107 x2</b>		<b>USB x1</b>

	<b>B4</b> 38,1 mm 1 1/2"	<b>B696 x8</b>
	31,75 mm 1 1/4"	<b>C935 x2</b>
	<b>S4</b> 19 mm 3/4"	<b>A911 (0111) x16</b>
	<b>B1</b> 14,7 mm 3/16"	<b>A247 (0147D) x4</b>
	<b>S3</b> 12 mm 1/2"	<b>A411 (0111A) x195</b>
	<b>S2</b> 9,5 mm 3/8"	<b>A511 (0111C) x10</b>
		<b>A337 (0037A) x217</b>
		<b>M907 x14</b>
		<b>M044 x6</b>
		<b>M040 x4</b>
		<b>M201 x4</b>
		<b>C994 x1</b>
		<b>C993 x1</b>



**CONSTRUCTION TIPS**  
**ASTUCES DE CONSTRUCTION**  
 TIPS DE CONSTRUCCIÓN  
 TIPPS ZUM BAUEN  
 MONTAGETIPS  
 SUGGERIMENTI PER COSTRUIRE  
 DICAS DE MONTAGEM  
 РЕКОМЕНДАЦІЇ ПО СБОРКЕ

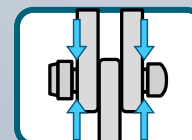
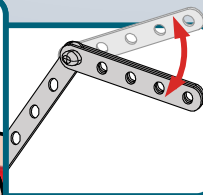
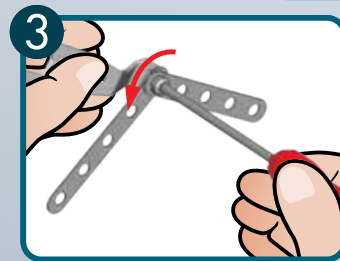
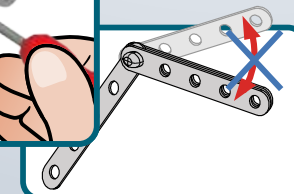
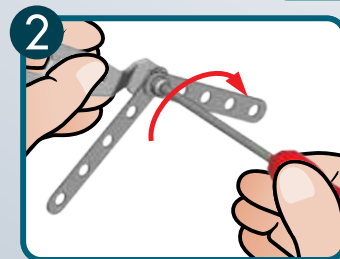
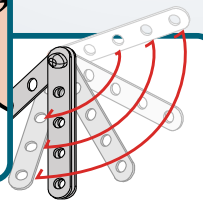
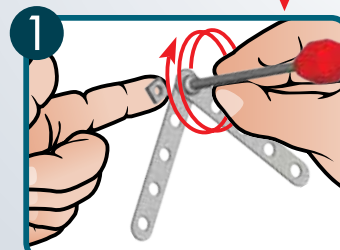
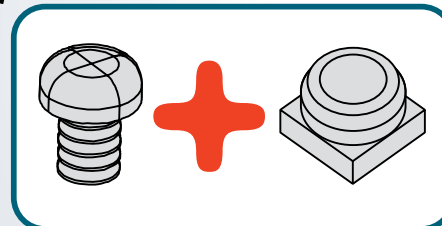
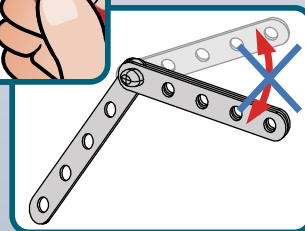
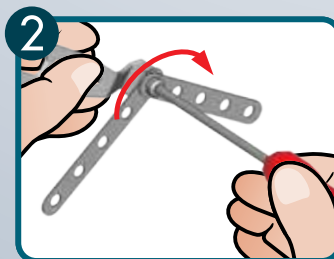
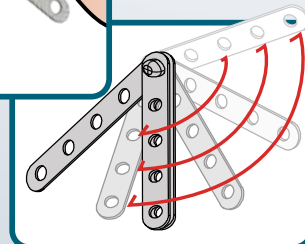
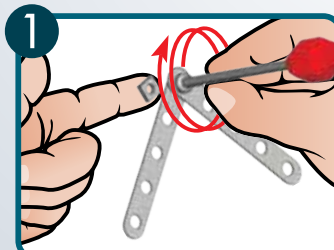
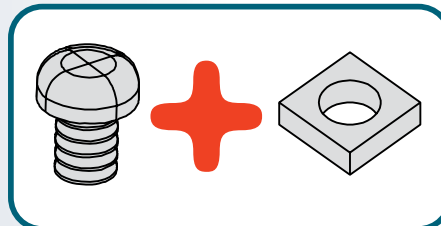
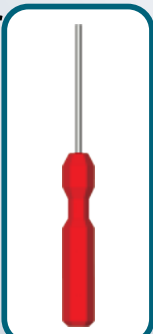

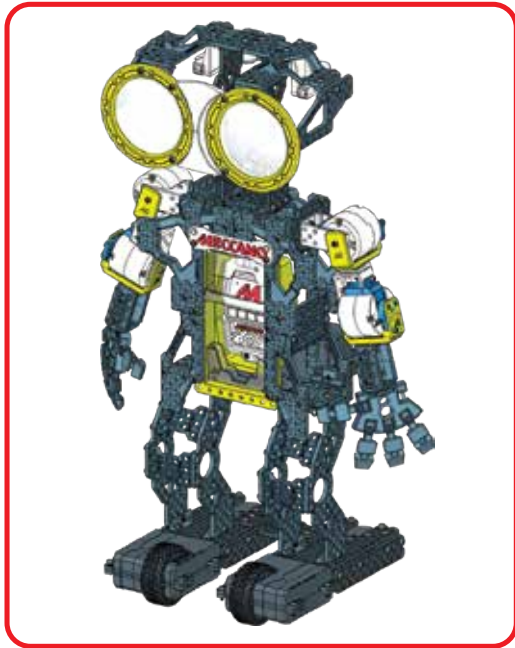

**1**

	x1		31,75 mm 1 1/4"	x2
	x1			x2

	1:1
--	-----

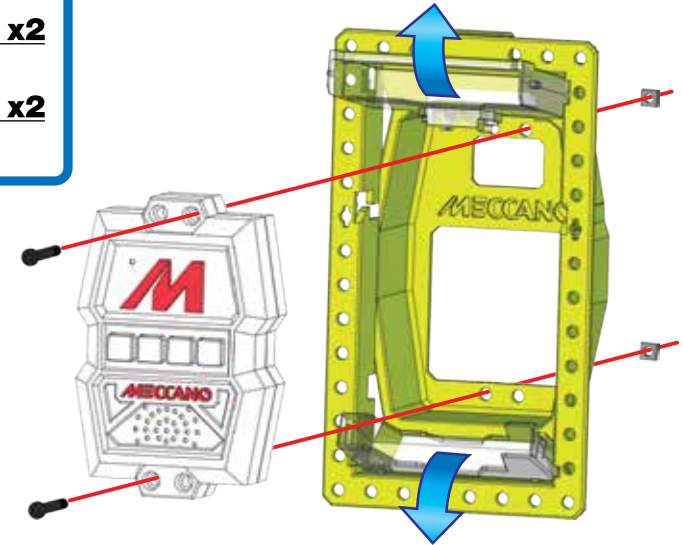
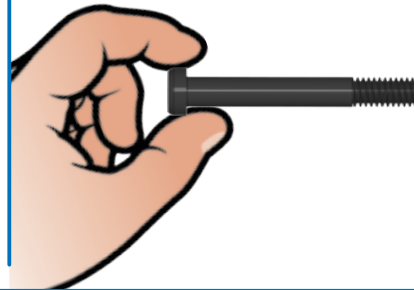

**2**

	x1	
	x1	
	x2	
	12 mm 1/2"	x8
		x8

	S3	1:1
--	----	-----

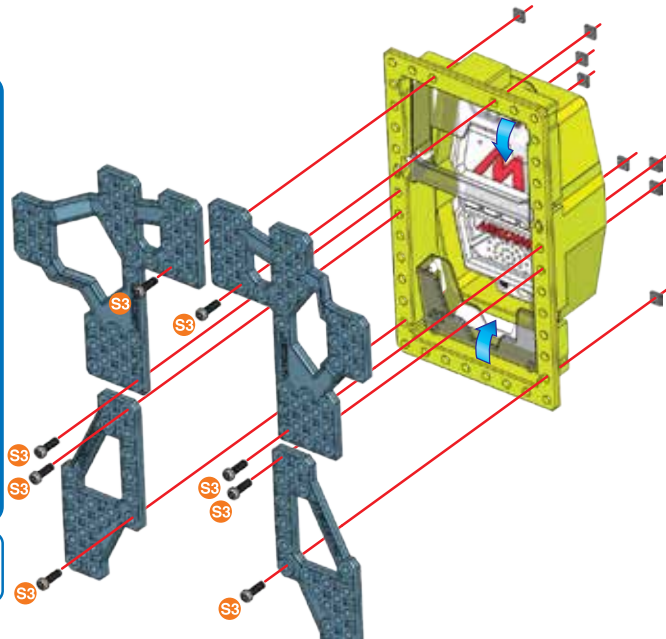

**3**

	x1	
	19 mm 3/4"	x2
		x2

	S4	1:1
--	----	-----

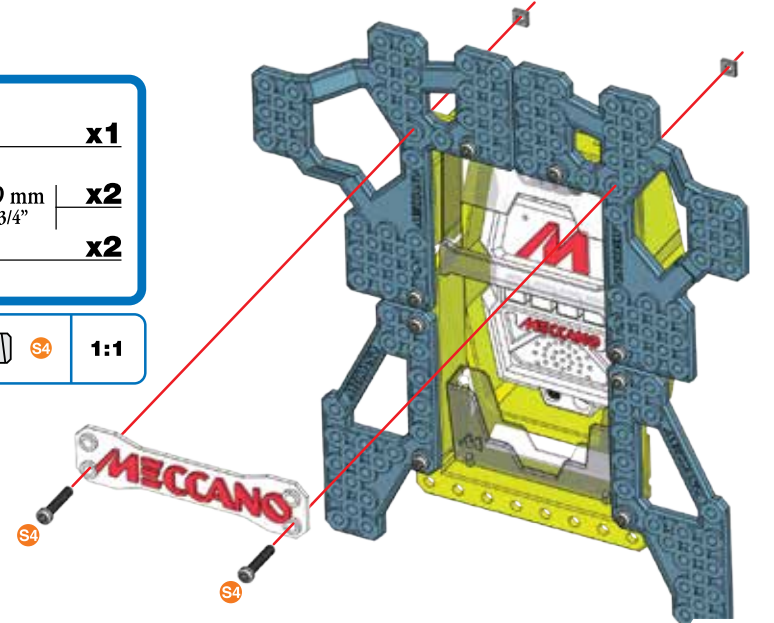

4

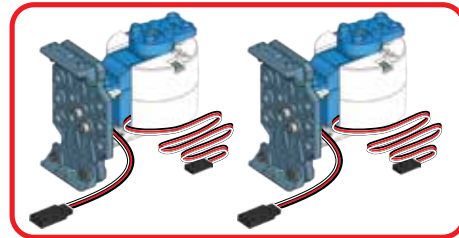
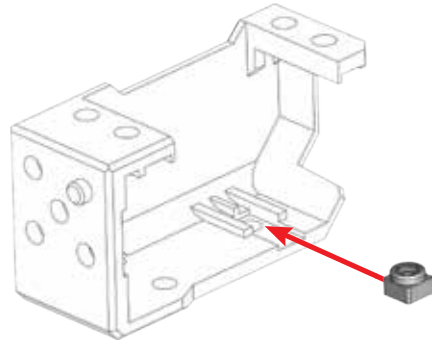
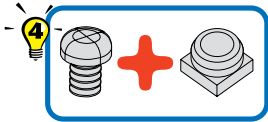
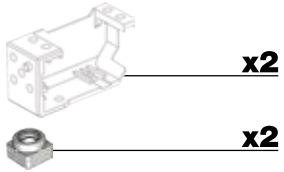

2x

5

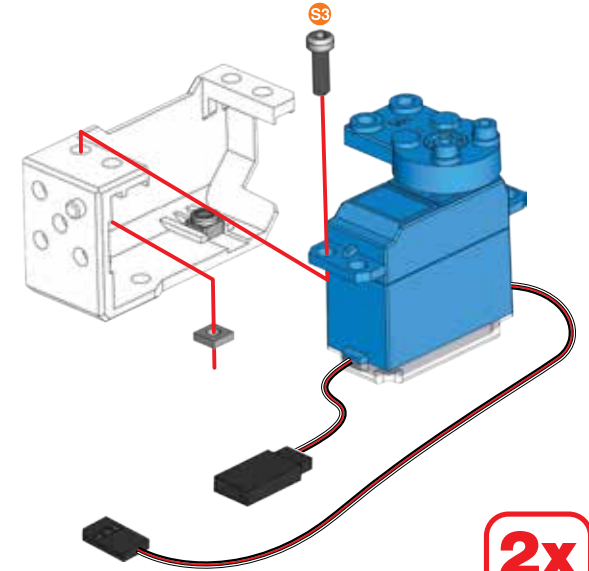
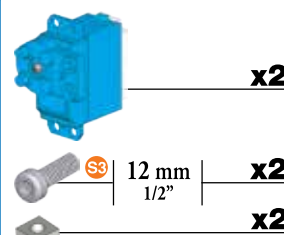

2x

6

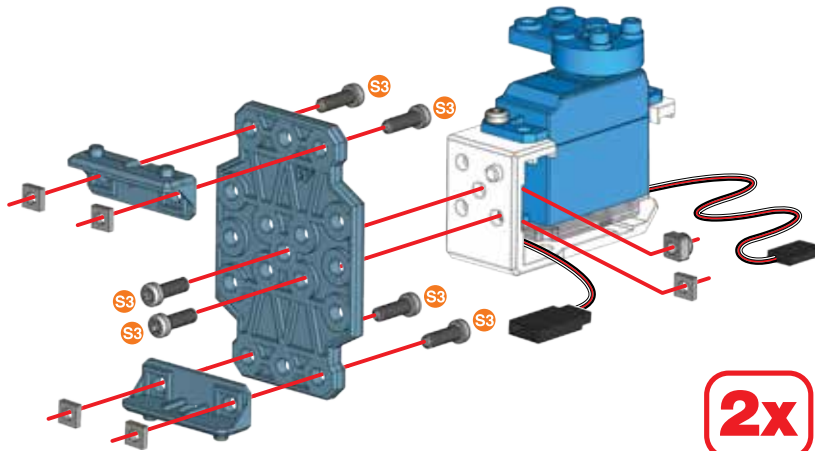
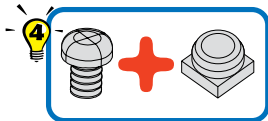
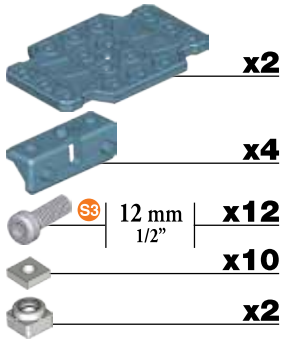

2x

7

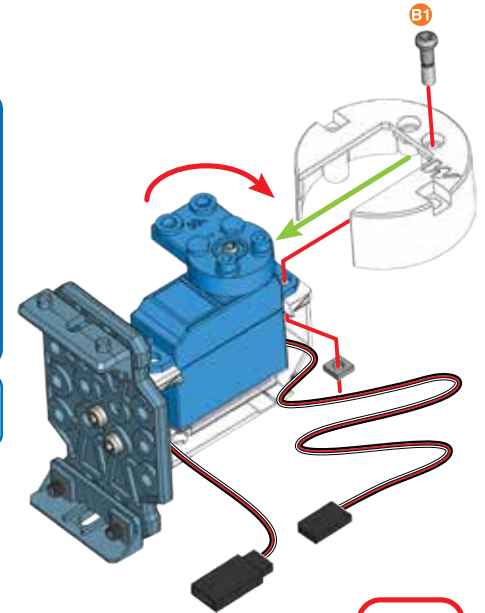
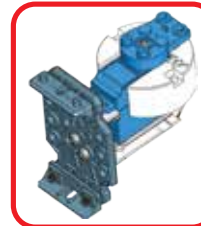
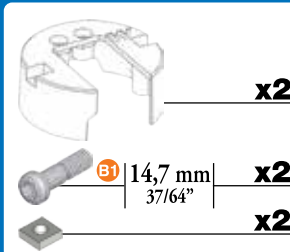

2x



8

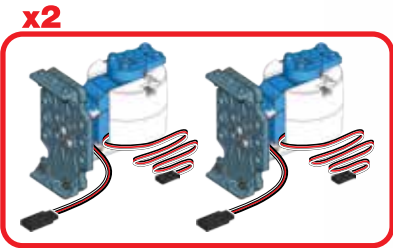
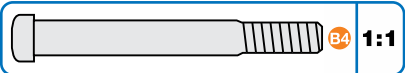
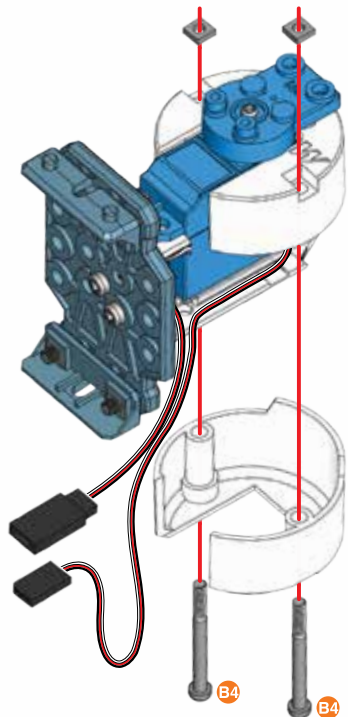
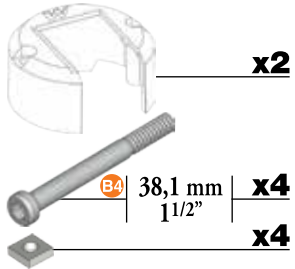

9

3 + 8 +

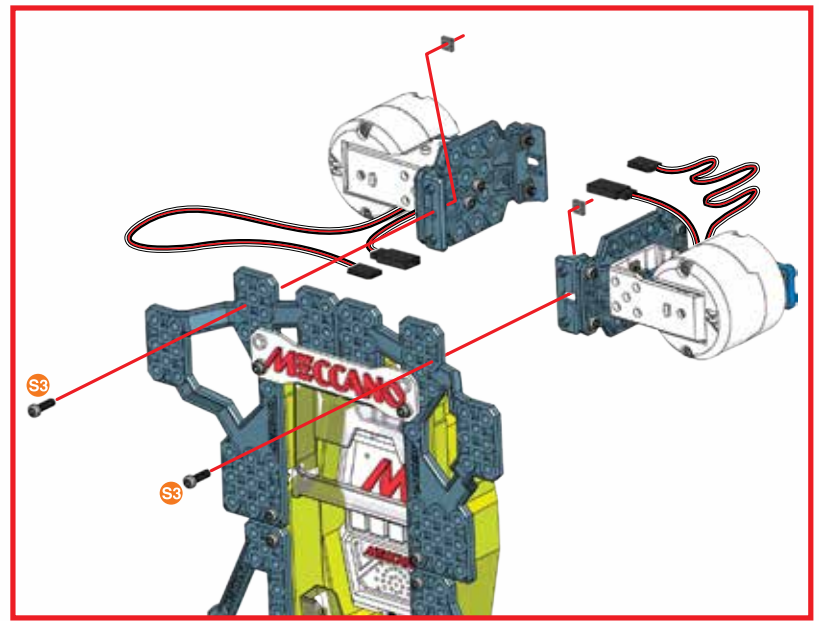
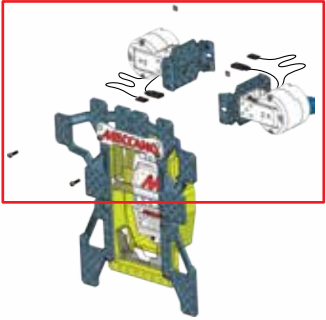
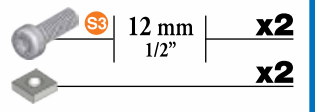

10

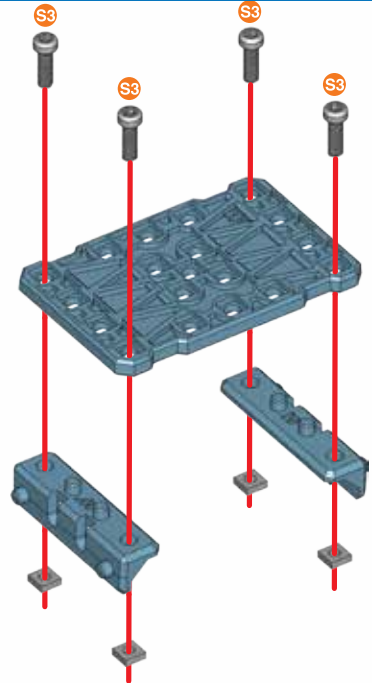
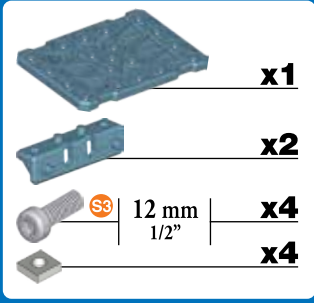

11

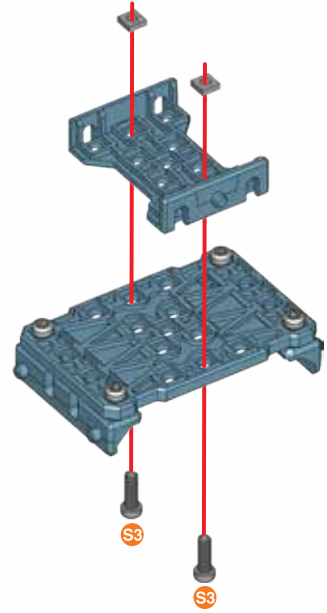
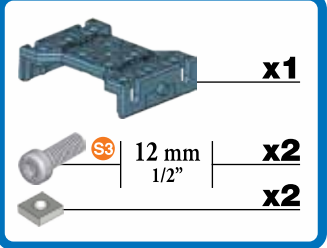

# 12

11+



x1

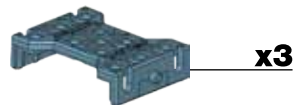

x3

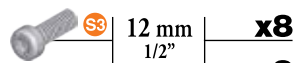

x8

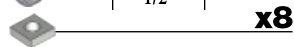

x8



S3

1:1

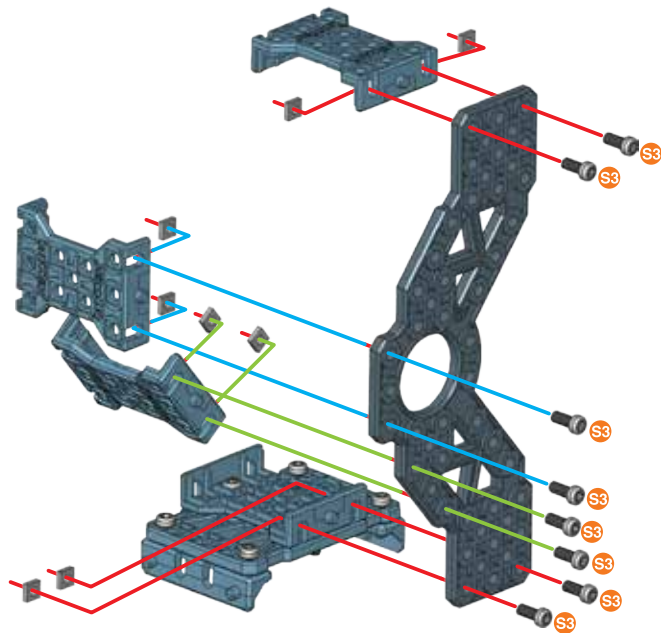

# 13



x1

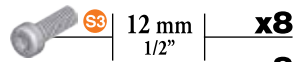

x8

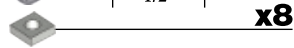

x8



S3

1:1

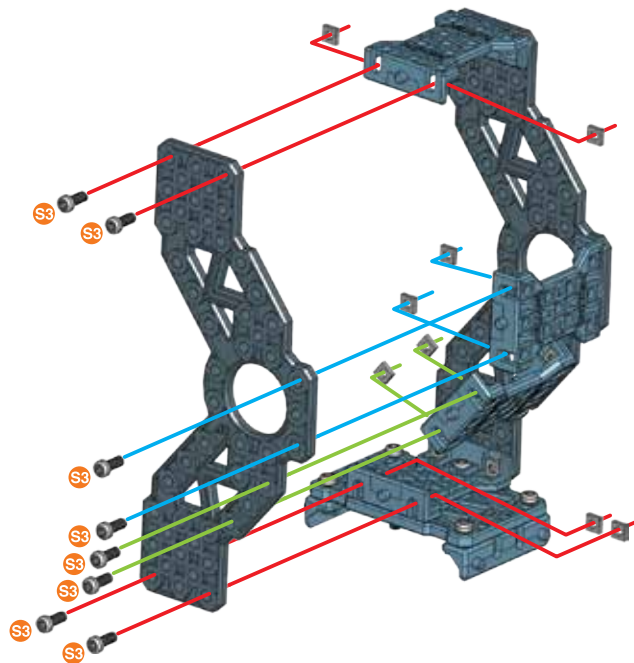

# 14

9 + 13+



12 mm  
1/2"

x2



x2





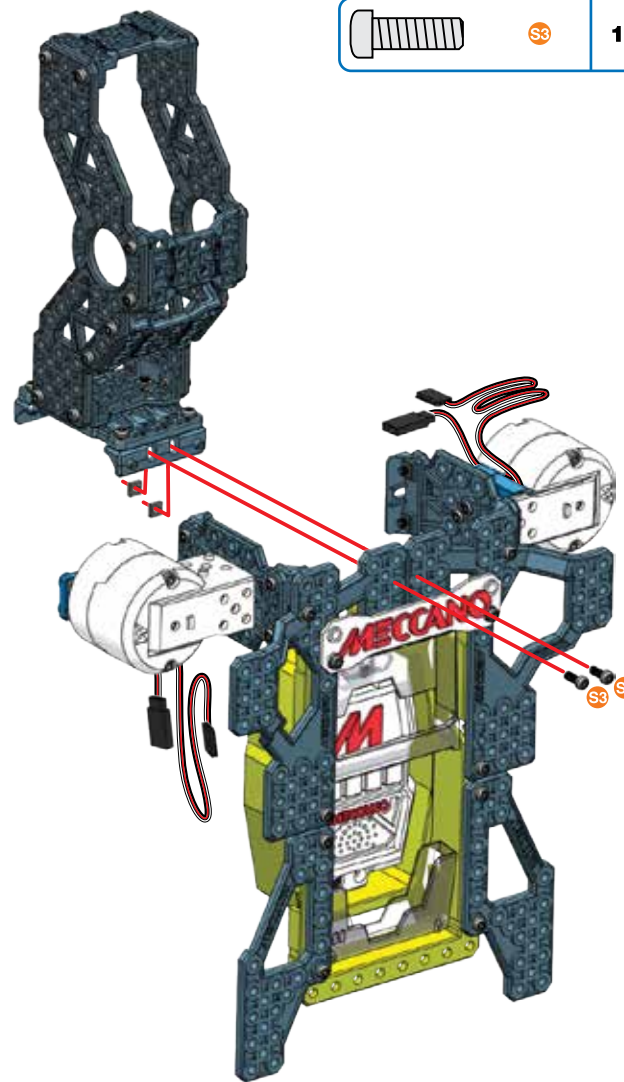

S3

1:1



15

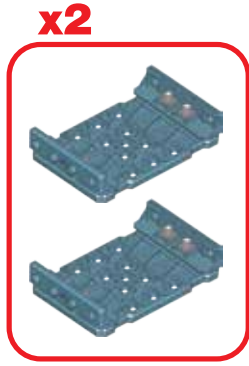
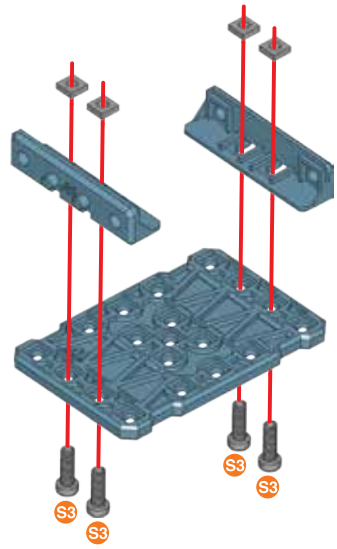

-  **x2**
-  **x4**
-  12 mm | **x8**
-  **x8**

	<b>S3</b>	<b>1:1</b>
--	-----------	------------



16



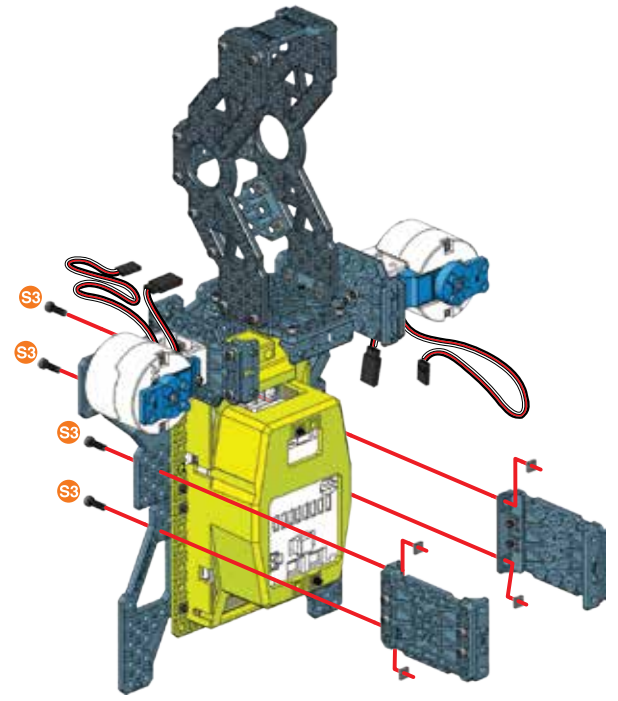

14 + 15 +

-  12 mm | **x4**
-  **x4**

	<b>S3</b>	<b>1:1</b>
---	-----------	------------



17

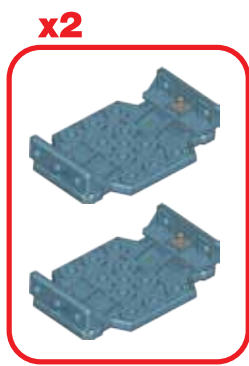
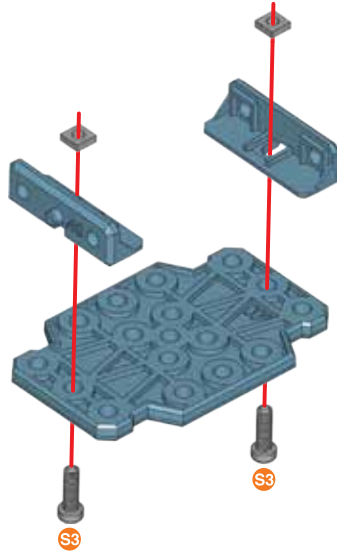

-  **x2**
-  **x4**
-  12 mm | **x4**
-  **x4**

	<b>S3</b>	<b>1:1</b>
--	-----------	------------



18

16 + 17 +

-  12 mm | **x4**
-  **x4**

	<b>S3</b>	<b>1:1</b>
---	-----------	------------

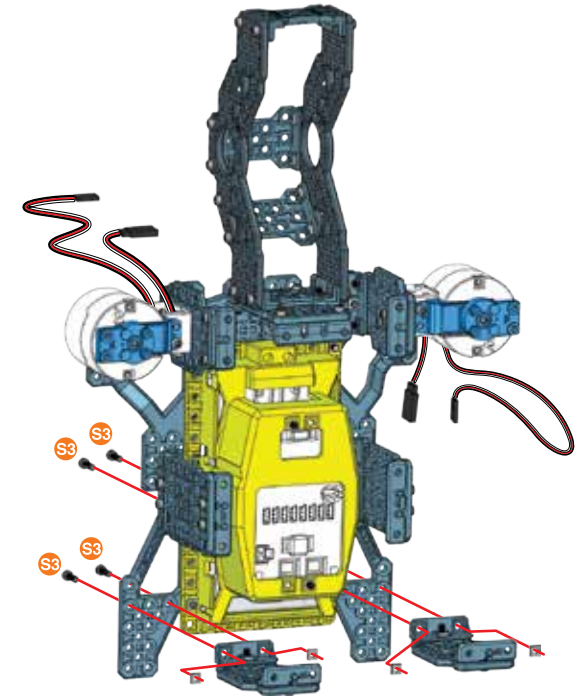



19



x1



x1

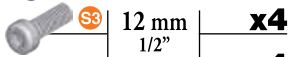

x4



x4



1:1

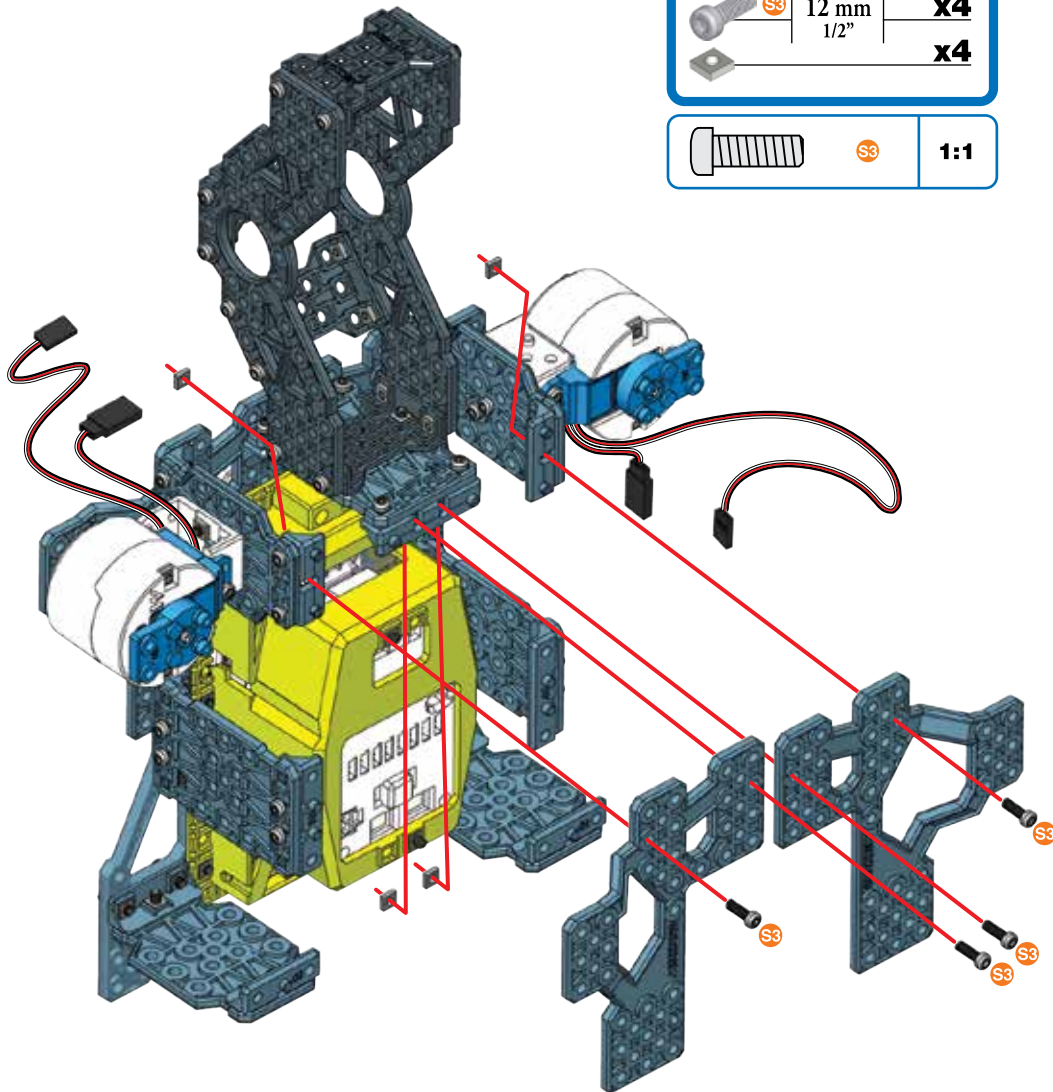

20

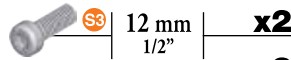

x2



x2



1:1

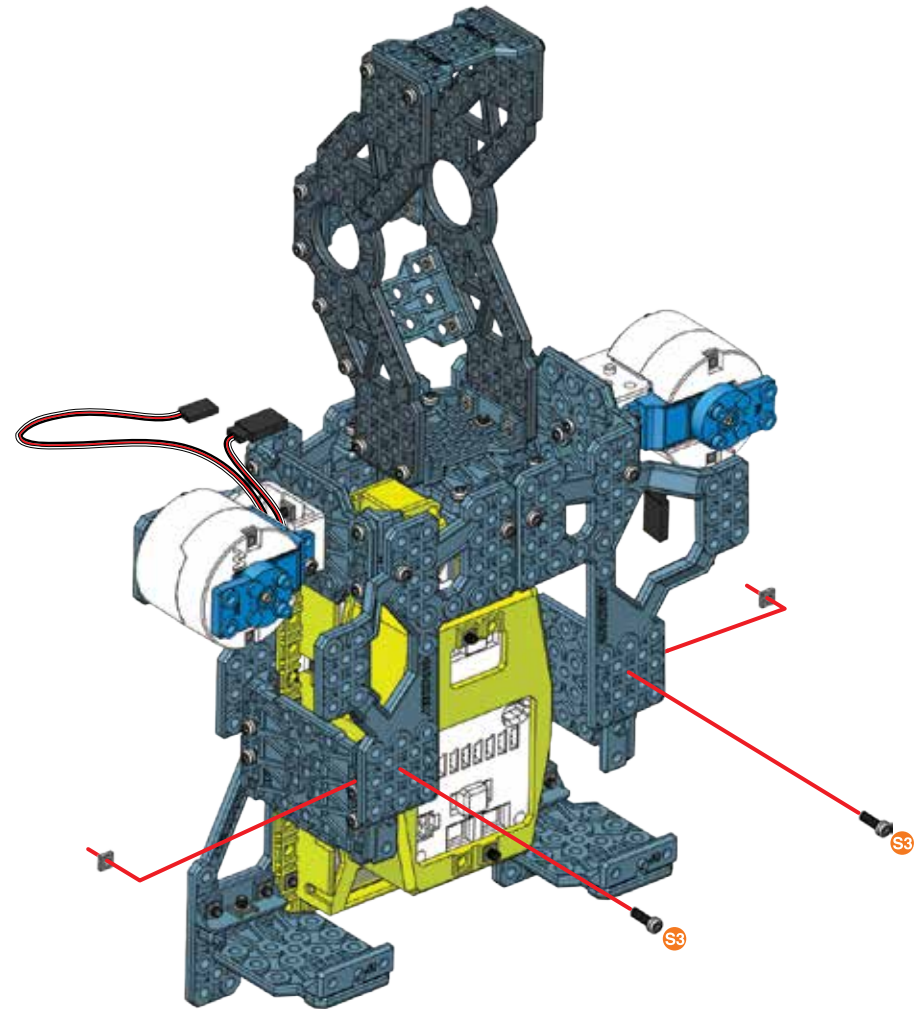



21

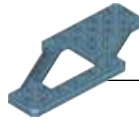

x2



12 mm  
1/2"

x6



x6



S3

1:1

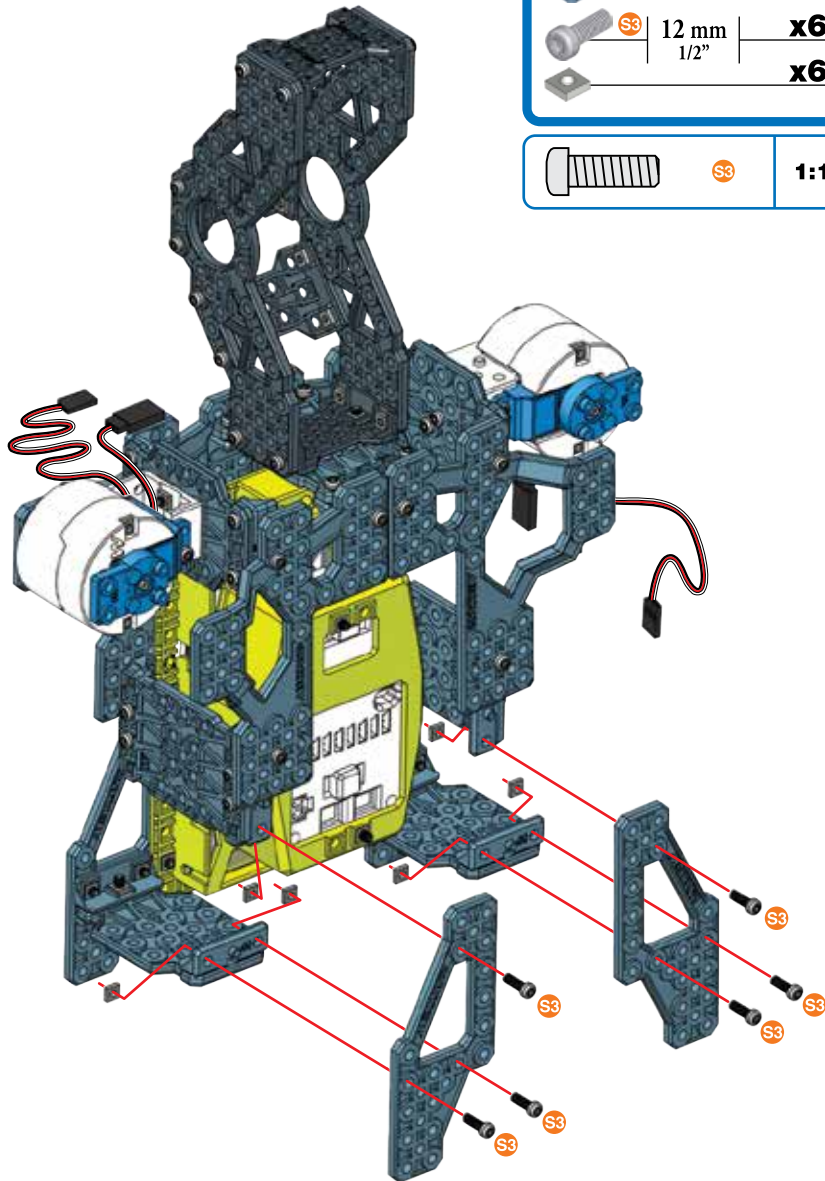

22



x1



12 mm  
1/2"

x4



x4

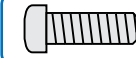

S3

1:1

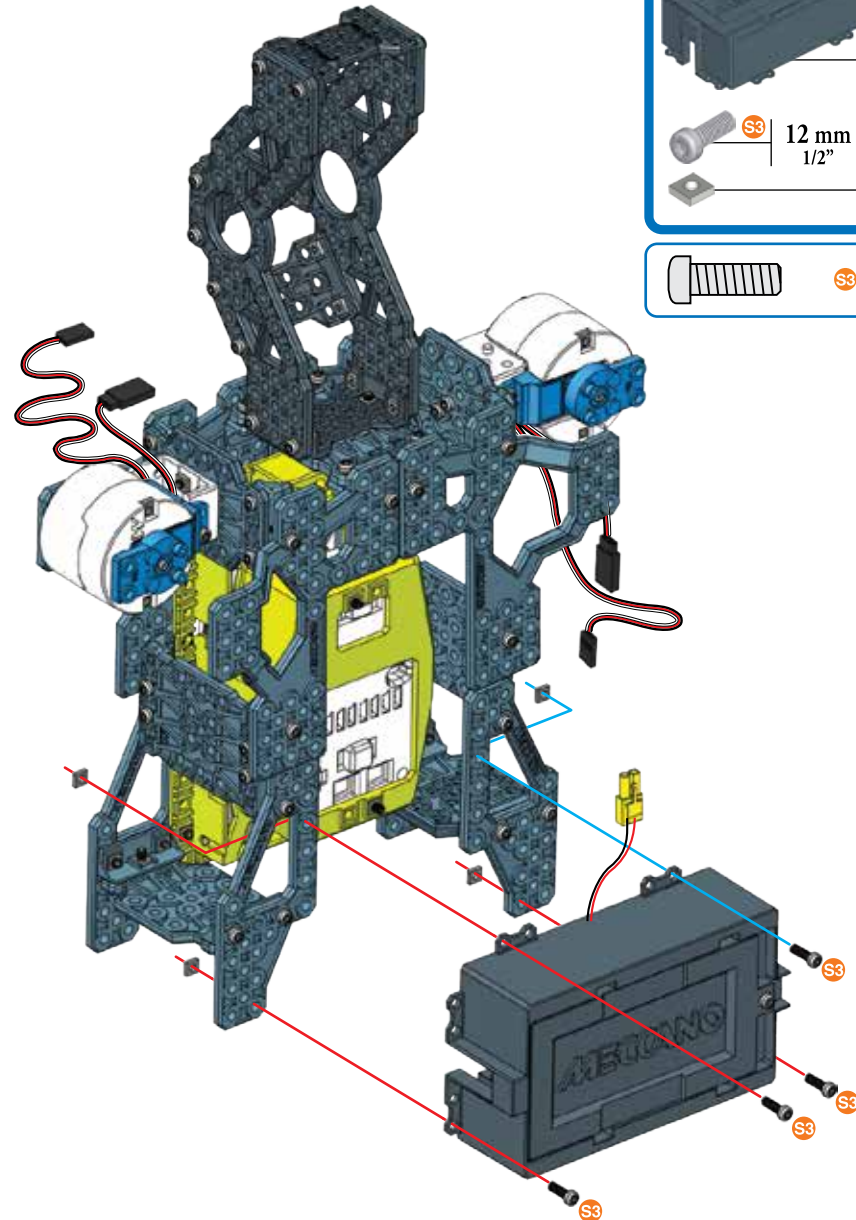

# 23

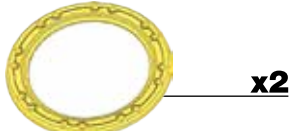

x2

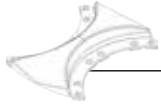

x1



x4

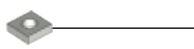

x4



1:1

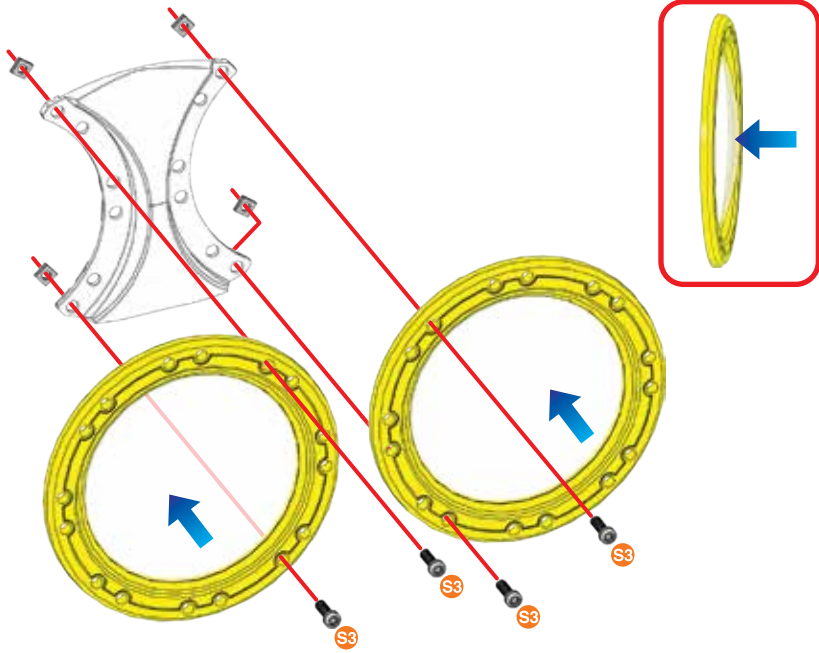

# 24



x1

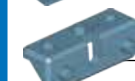

x2



x3



x3



1:1

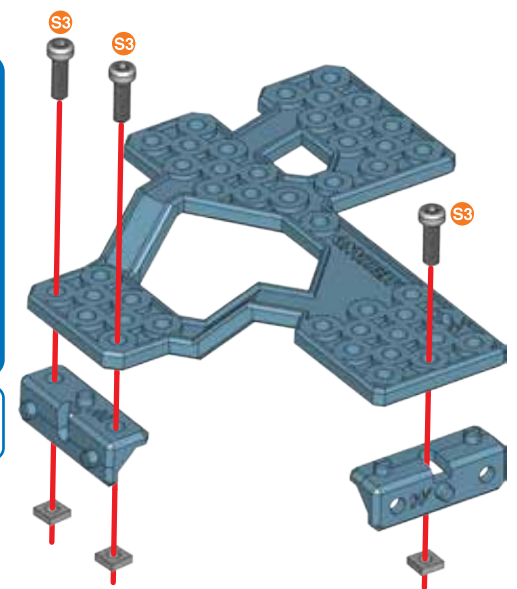

# 25

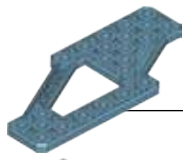

x1



x1



x1



1:1

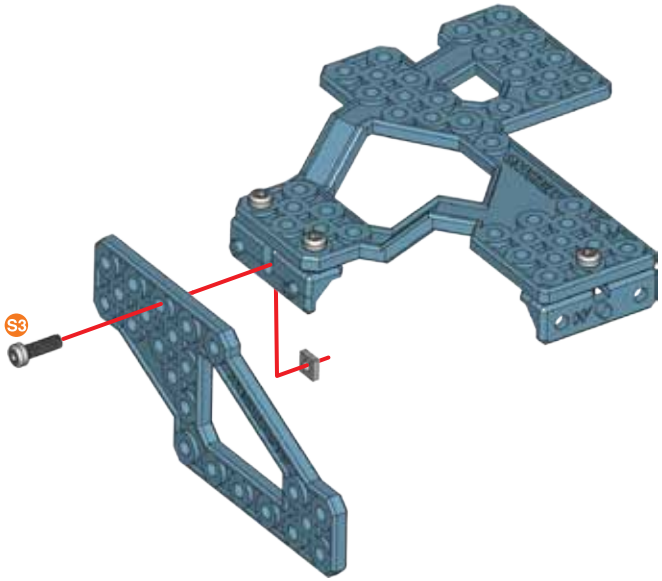

# 26

23 + 25 +



x1

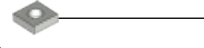

x1



1:1

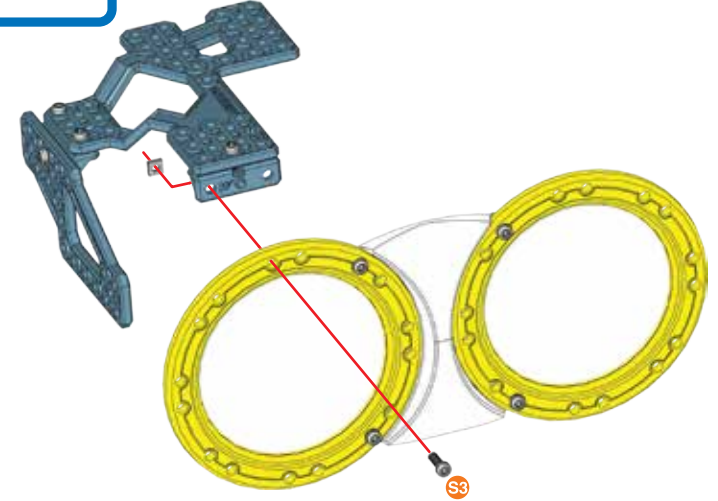

27

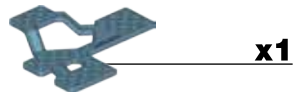

x1

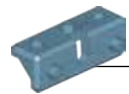

x2

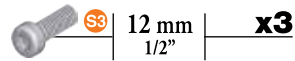

x3

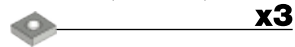

x3



1:1

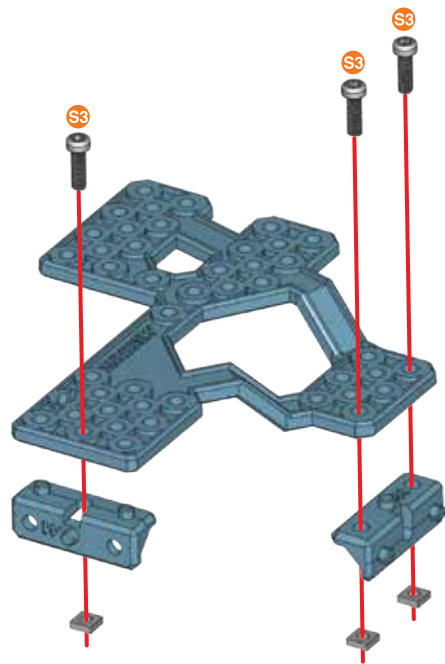

28

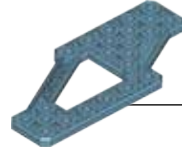

x1

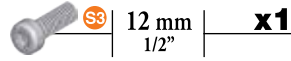

x1

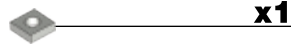

x1



1:1

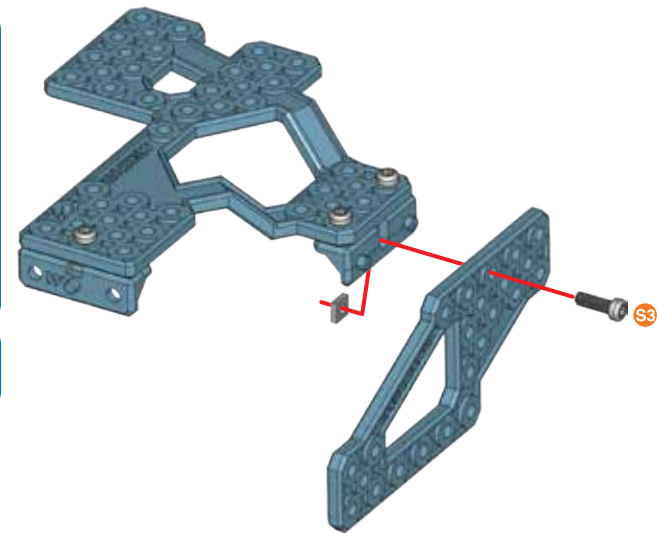

29

26 + 28 +

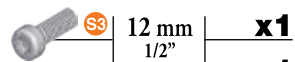

x1

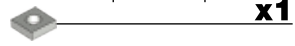

x1



1:1

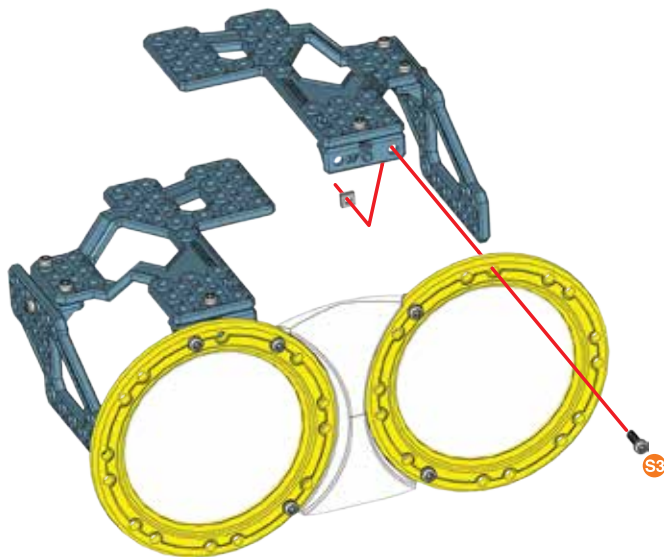

30

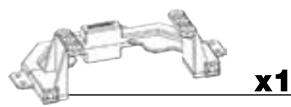

x1

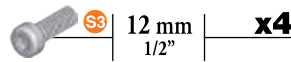

x4

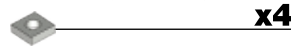

x4



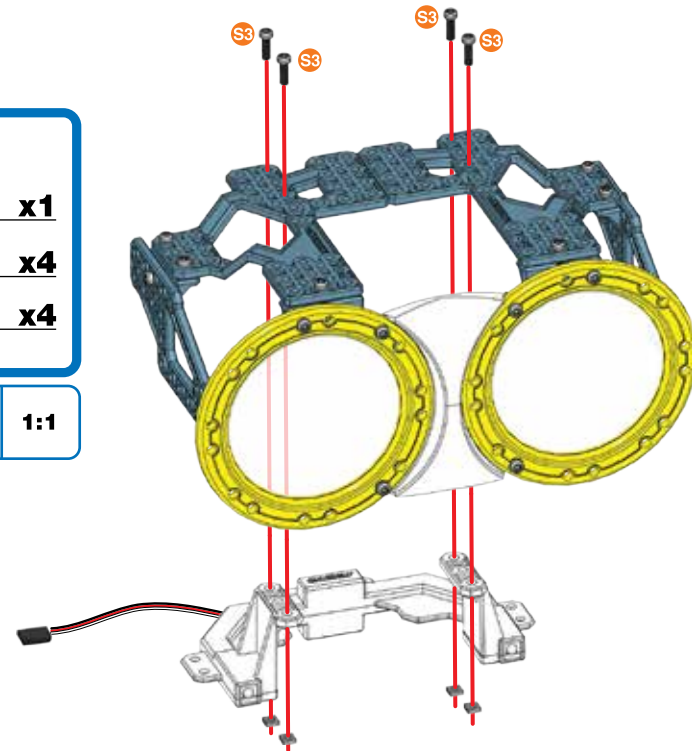

1:1







**31****22 + 30 +**

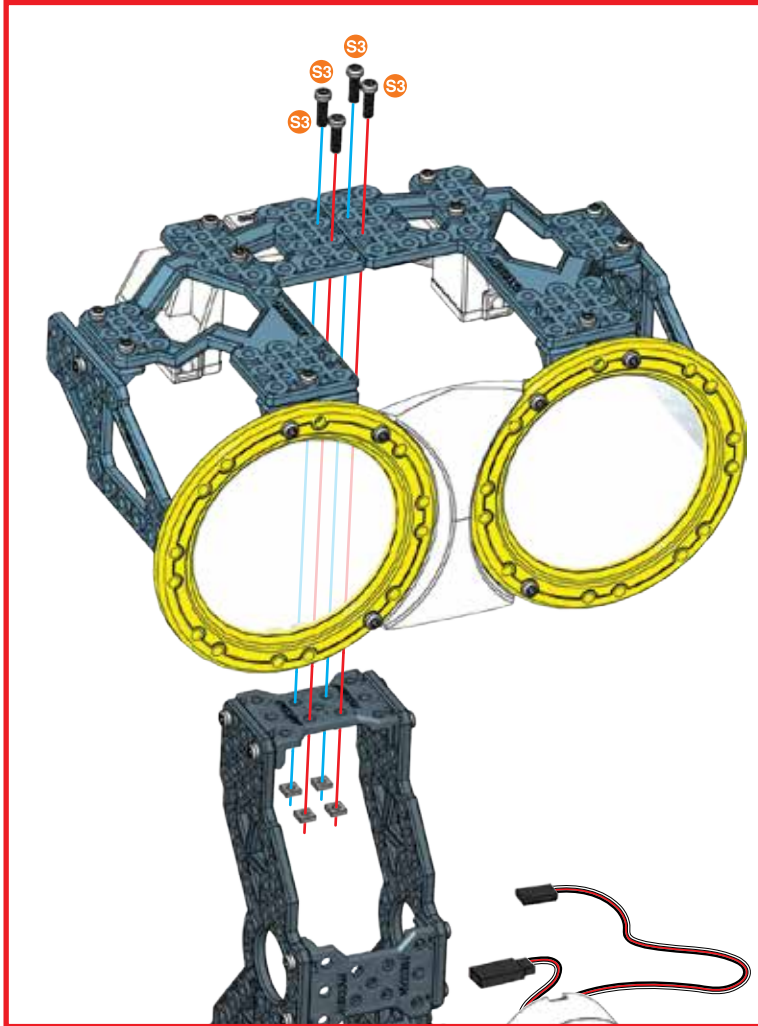

	12 mm 1/2"	<b>x4</b>
		<b>x4</b>

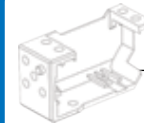
	<b>S3</b>	<b>1:1</b>
---	-----------	------------

**32**

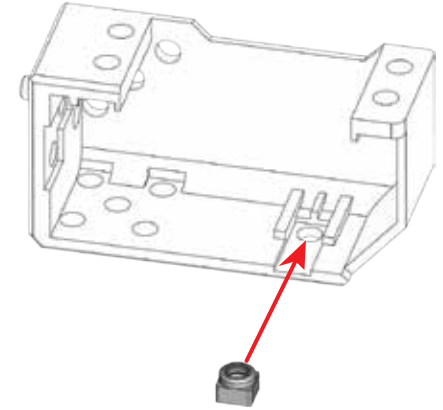
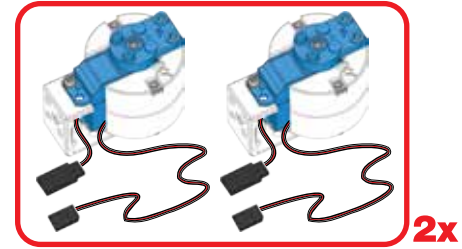
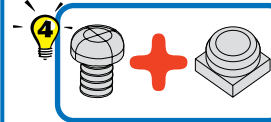
	<b>x2</b>
	<b>x2</b>

**33**

	<b>x2</b>	
	12 mm 1/2"	<b>x2</b>
		<b>x2</b>

	<b>S3</b>	<b>1:1</b>
---	-----------	------------

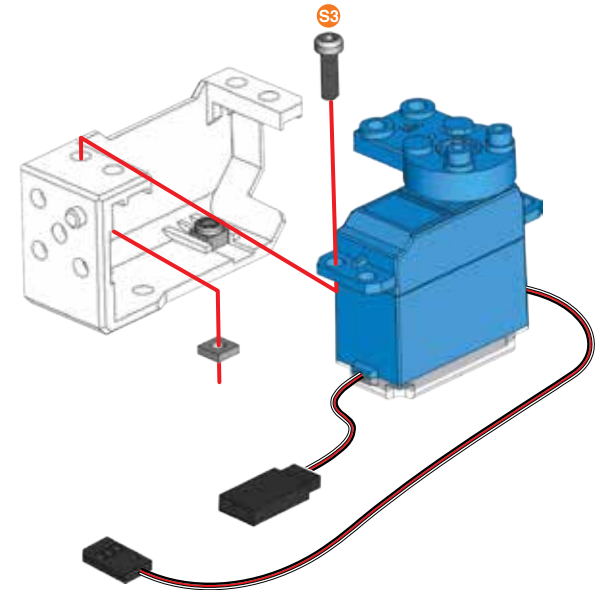
**2x**



34

- x2
- 14,7 mm | 37/64" x2
- x2

- x1

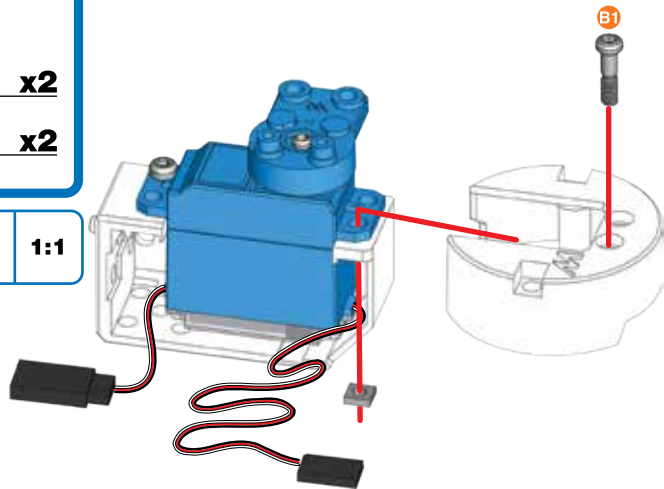

2x

35

- x2
- 38,1 mm | 1 1/2" x4
- x4

- x1

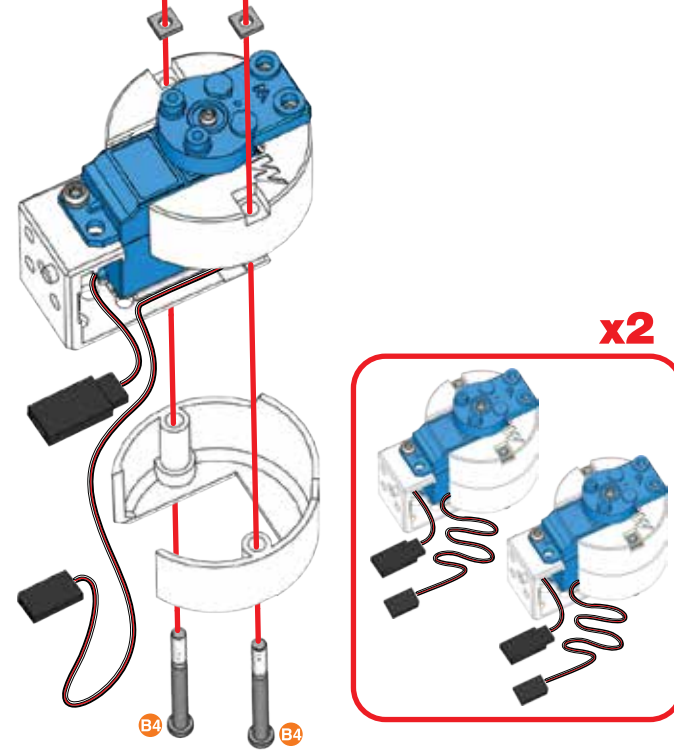

36

- x1
- x1
- 19 mm | 3/4" x1
- x1

- x1

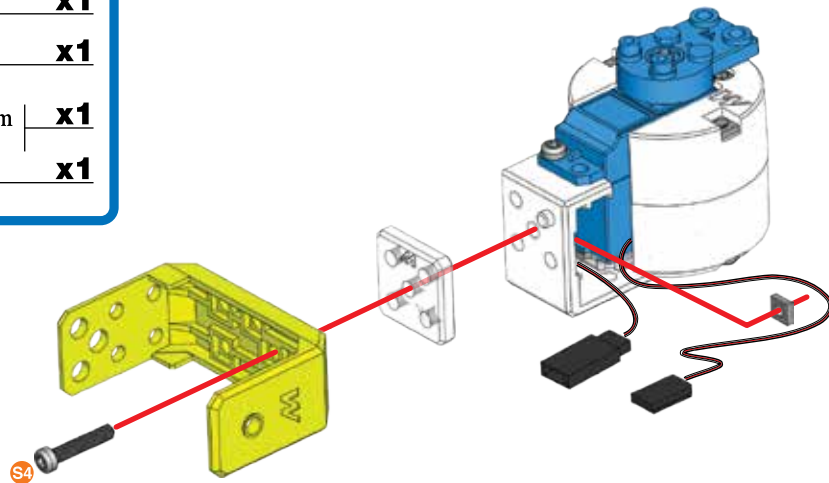

37

- x1
- x1
- 12 mm | 1/2" x1
- x1

- x1

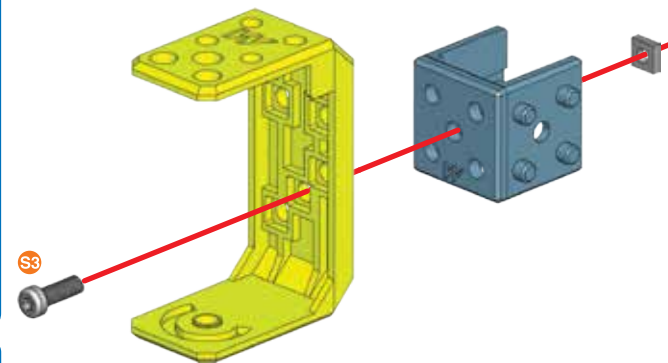

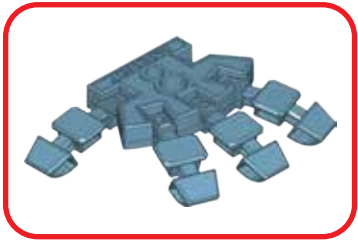
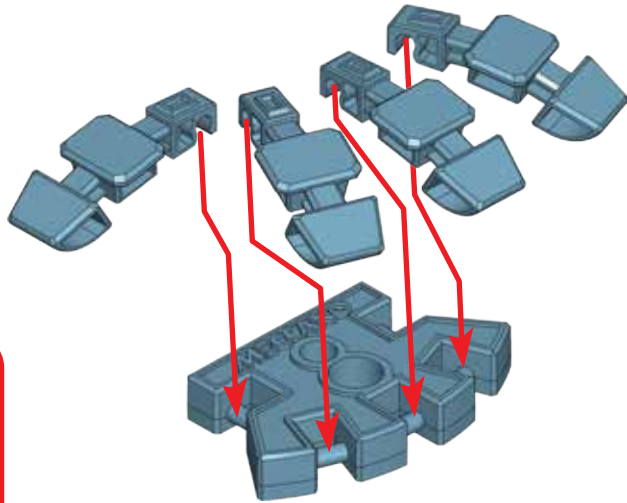
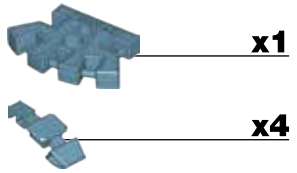
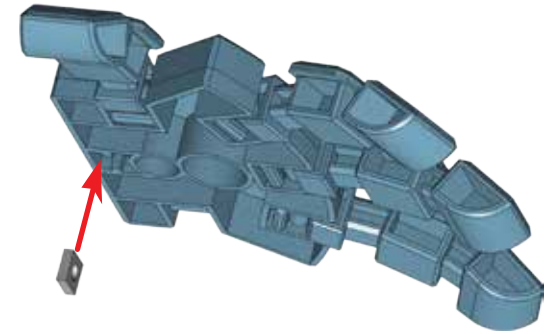
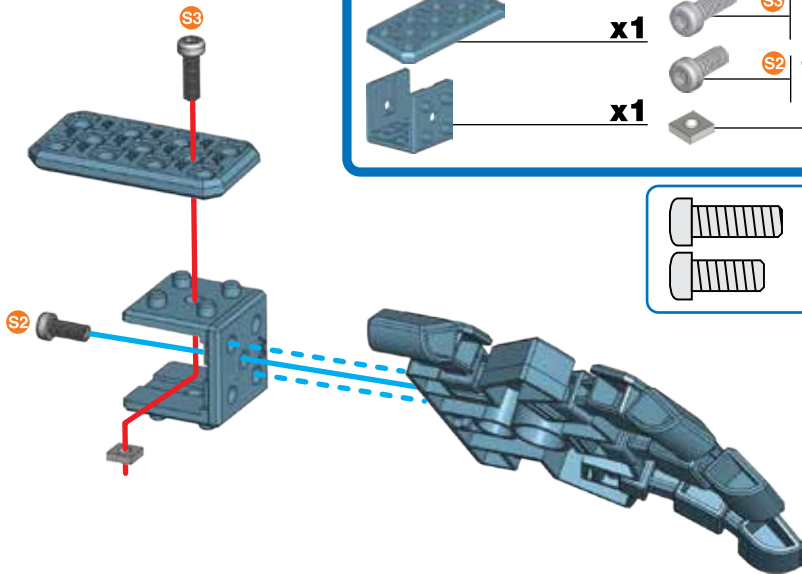
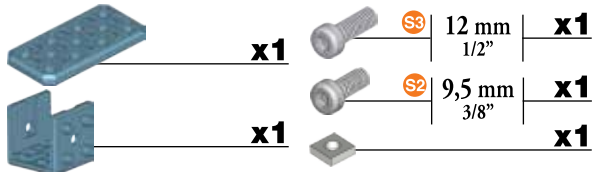
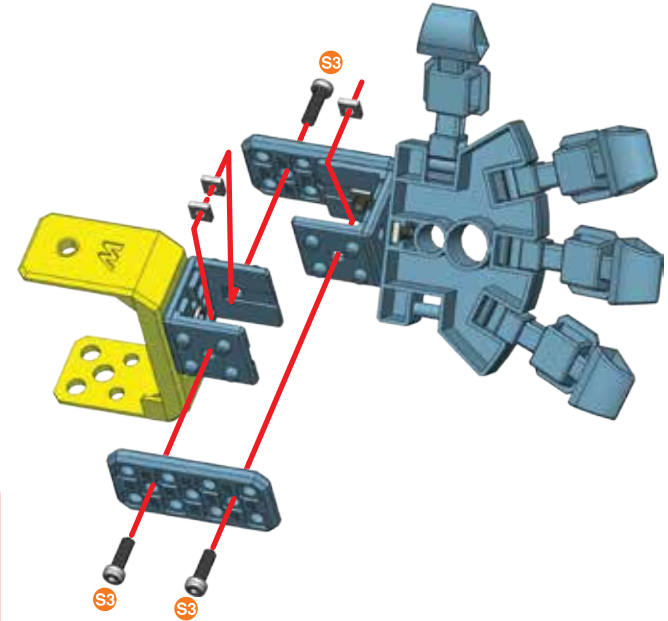
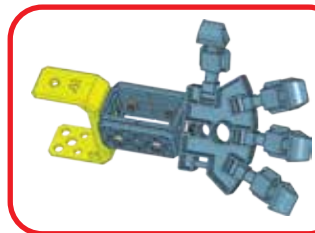
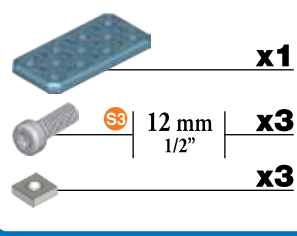
**38****39****40****41****37 + 40 +**

### 42 36 + 41 +

	S2	9,5 mm 3/8"	<b>x1</b>
---	----	----------------	-----------

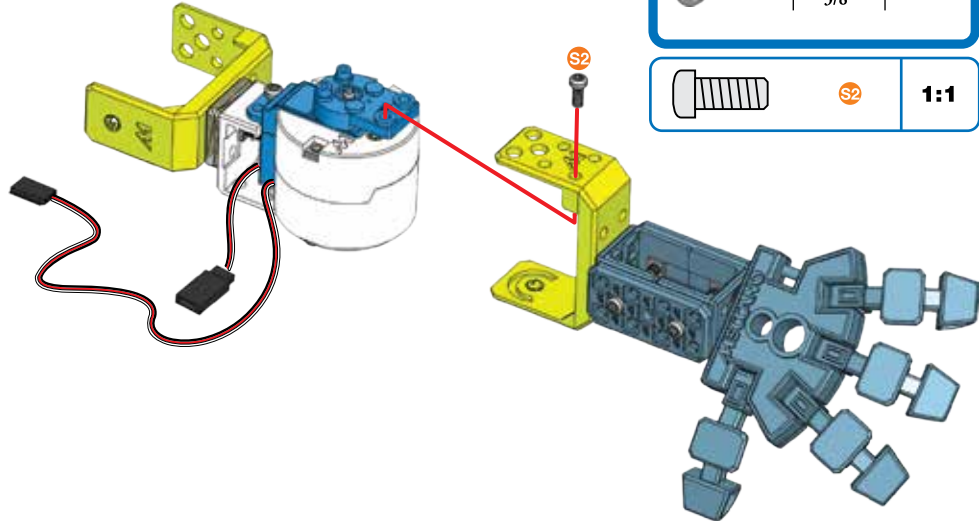

	S2		<b>1:1</b>
---	----	--	------------



### 43

	S2	9,5 mm 3/8"	<b>x1</b>
---	----	----------------	-----------

	S2		<b>1:1</b>
---	----	--	------------



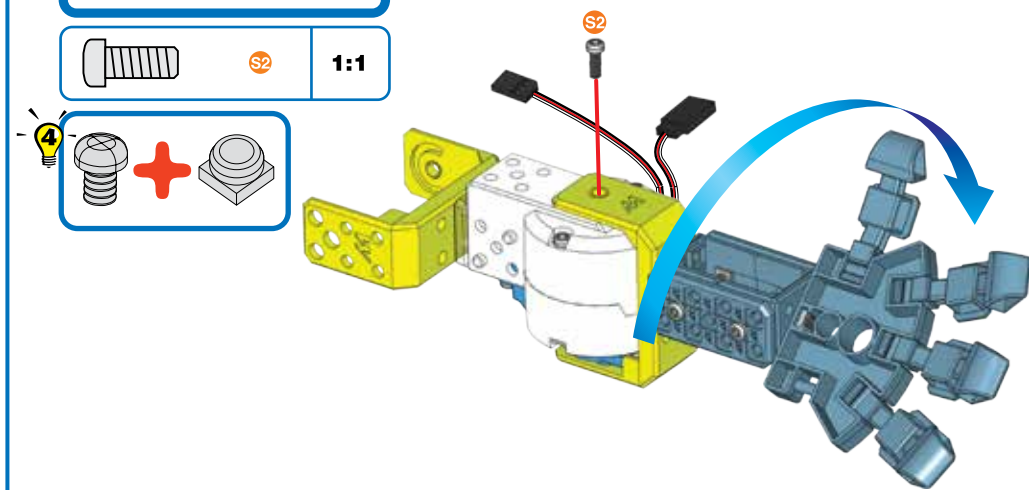

+



### 44 31 + 43 +

	S2	9,5 mm 3/8"	<b>x1</b>
--	----	----------------	-----------

	S2		<b>1:1</b>
--	----	--	------------

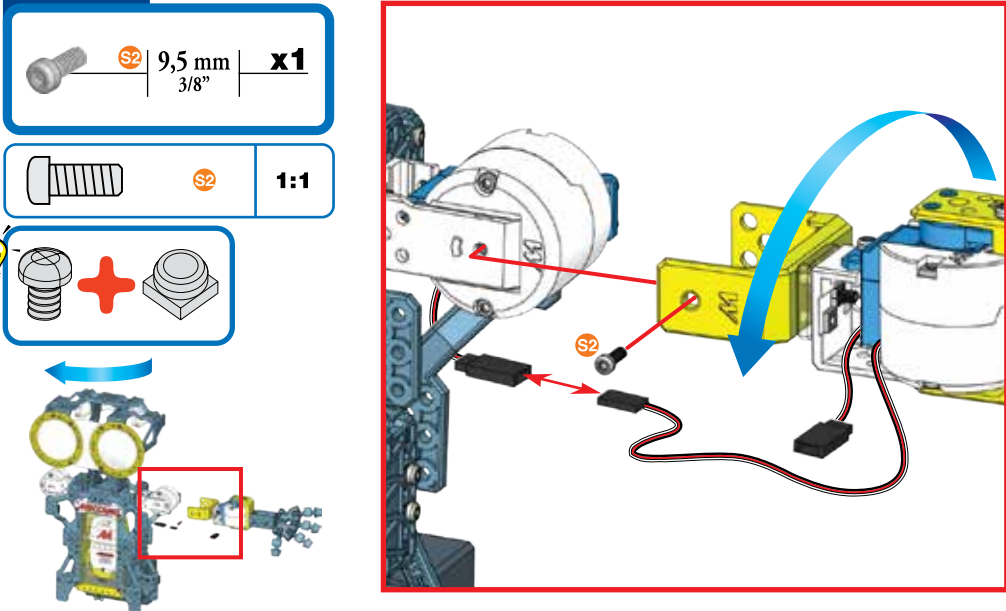

+



### 45

	S2	9,5 mm 3/8"	<b>x1</b>
---	----	----------------	-----------

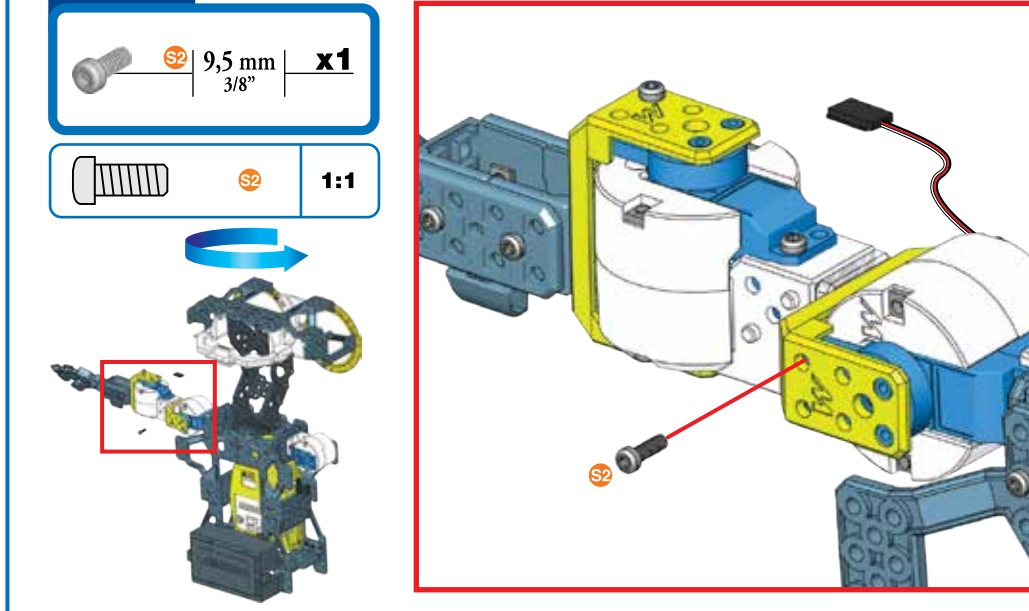
	S2		<b>1:1</b>
---	----	--	------------





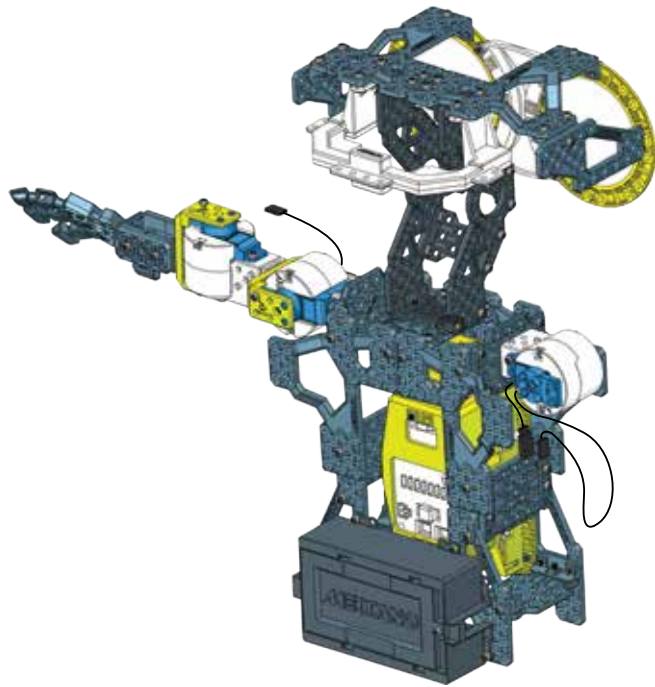

46



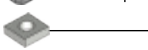

47

35+

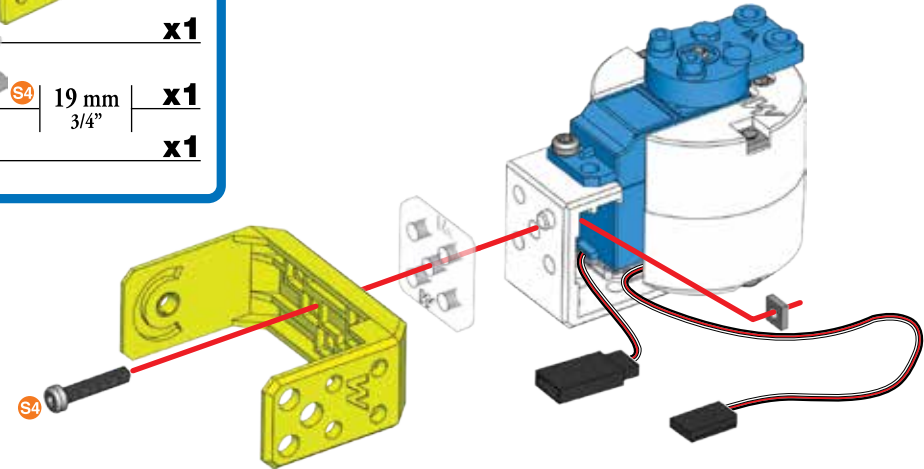
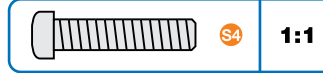
-  x1
-  x1
-  S4 19 mm 3/4" x1
-  x1



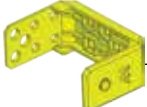
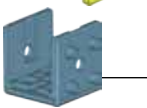

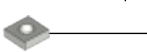
48

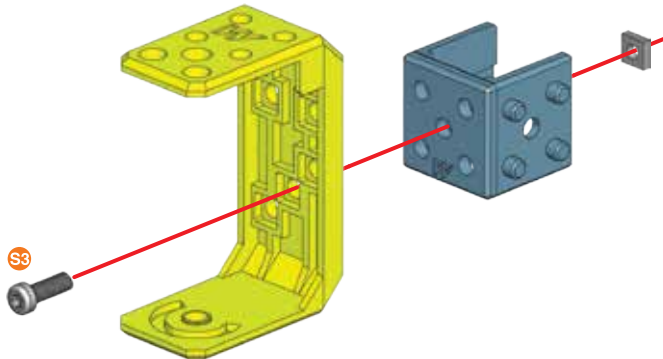
-  x1
-  x1
-  S3 12 mm 1/2" x1
-  x1



49

-  x1
-  x4

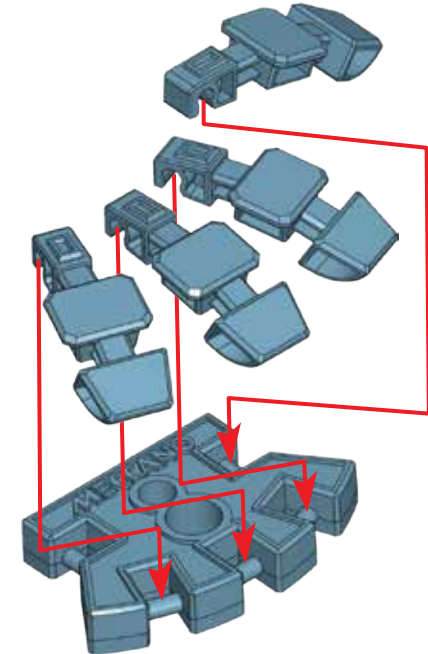







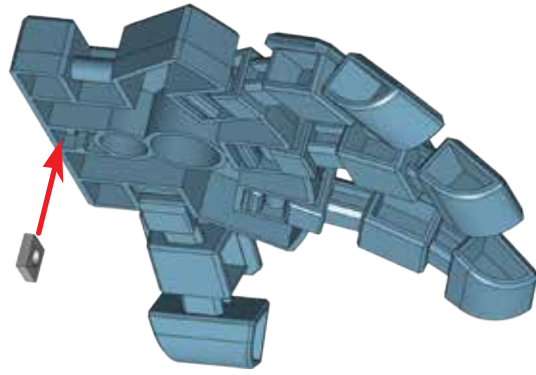

50

 x1



51

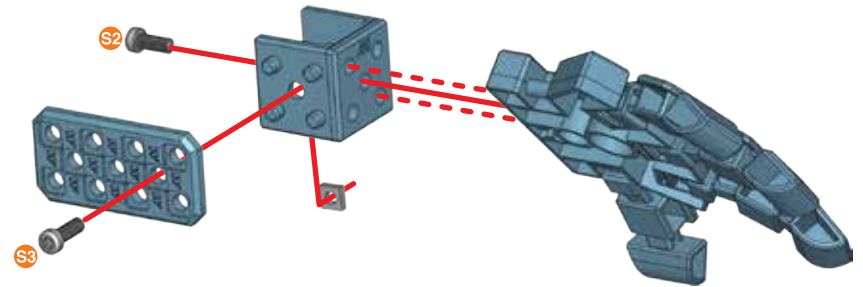

	x1	 S3   12 mm   1/2"	x1
	x1	 S2   9,5 mm   3/8"	x1
			x1

	S3	1:1
	S2	



52

48 + 51 +

	x1
 S3   12 mm   1/2"	x3
	x3

	S3	1:1
--	----	-----

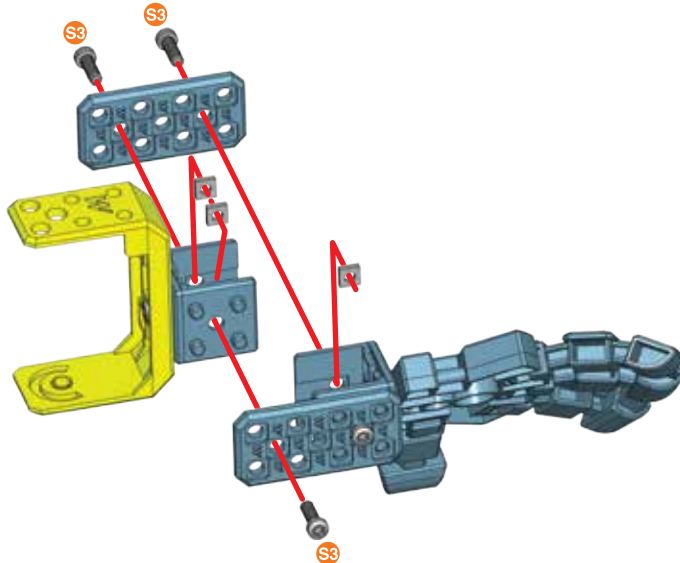
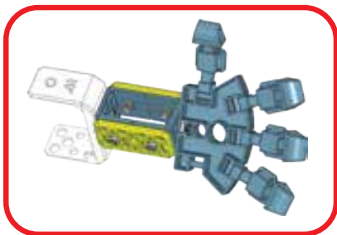

53

47 + 52 +

 S2   9,5 mm   3/8"	x1
--	----

	S2	1:1
---	----	-----

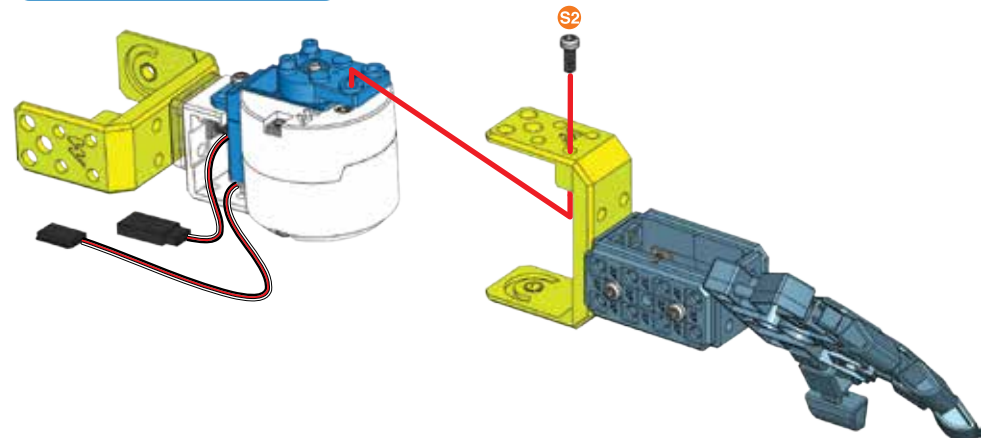

# 54

 S2 | 9,5 mm | **x1**  
3/8"

 S2 | **1:1**

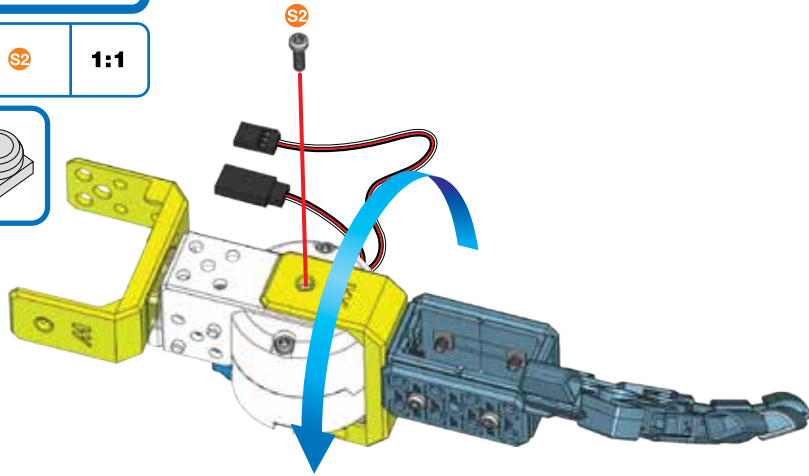
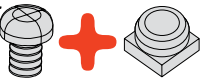

# 55

46 + 54 +

 S2 | 9,5 mm | **x2**  
3/8"

 S2 | **1:1**

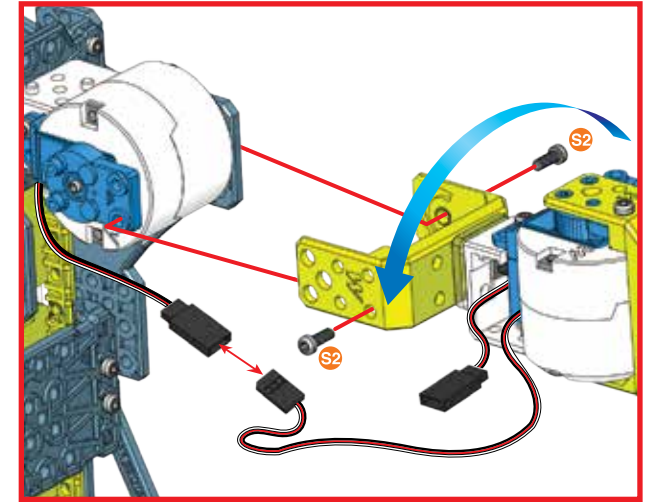

# 56

 **x2**

 **x6**

 S3 | 12 mm | **x12**  
1/2"

 **x12**

 S3 | **1:1**

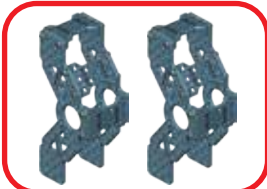

**2x**

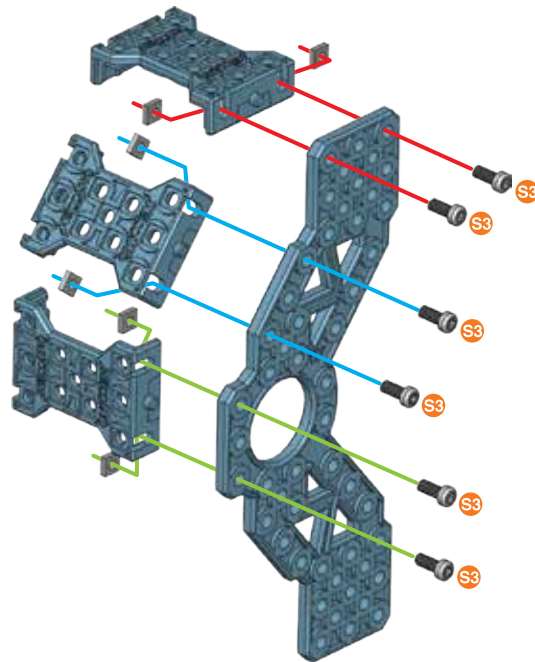

# 57

 **x2**

 S3 | 12 mm | **x12**  
1/2"

 **x12**

 S3 | **1:1**

**x2**

