

Latitude > 44° 49' 6" N
Longitude > 20° 28' 5" E

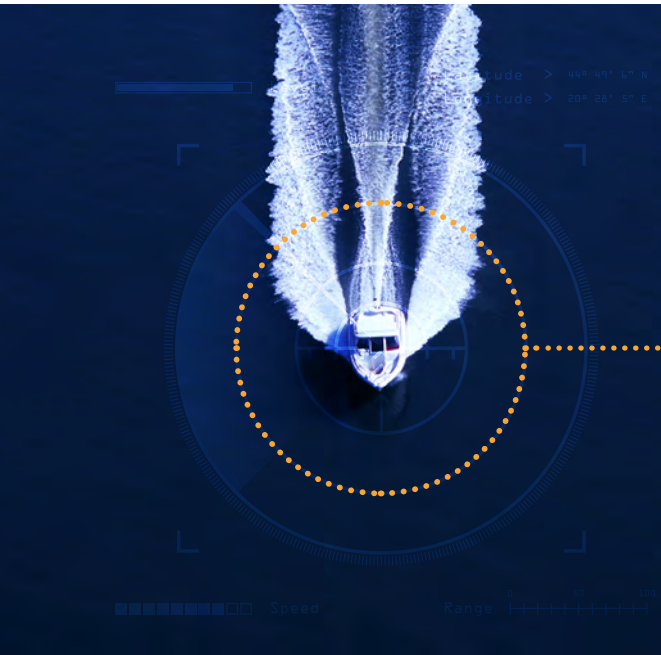

USER MANUAL

POWERED BY SPOT FUNCTIONALITY



GPS SECURITY SYSTEM

100% SATELLITE TECHNOLOGY



Range 0 50 100



Table of Contents

Welcome	3
Key Terminology	4
How HUG works	5
Getting Started	6
Initial System Setup/Test	12
Installation of Tracker and Keypad	15
Using SPOT HUG	18
How the LEDs Blink	23
Keypad Functions	26
Care, Support and Specifications	27
Warranty and FCC/IC Notice	29



SPOT HUG is a low-cost, easy to install satellite-based GPS asset monitoring, security and messaging system. It provides the asset owner with peace of mind when they are away from their asset via state-of-the-art asset tracking and sensor monitoring functionalities. When on the boat and in range of the Tracker, HUG also provides the owner with the ability to send messages and request help in an emergency. HUG works via satellite and provides coverage around the world in places where cellular coverage and VHF radio is lacking.

HUG uses GPS technology and Globalstar's Simplex satellite network to relay location information and messages to the end users and 3rd party service providers. HUG utilizes an onboard GPS chip to determine a highly accurate GPS location of the asset and sends the location information to Globalstar satellites. The satellites transmit the message to various Gateway Appliqués around the world and a global network routes the message to the appropriate network. The location and the message are delivered via email and text message according to the profile information provided by the customer during registration at findmeSPOT.com.

Sensor Alert monitoring notifications are delivered to contact information in the customer's profile. Emergency notifications are sent to the GEOS IERCC and Unauthorized Movement notifications are delivered to the Asset Monitoring Center. GEOS will coordinate with the local authority to begin a search and rescue effort or a theft recovery effort (where available).

SPOT HUG (HUG) is comprised of three (3) hardware components to provide an indispensable asset protection security system.



The core Tracker unit contains the satellite transmitter unit, an internal GPS chip set, wireless transceiver at 2.4 GHz and a vibration sensor chip.

- The Tracker can be powered by batteries (4 AA Energizer Lithium (L91) batteries included) or line power.



The Keypad wirelessly connects to the Tracker for arming/disarming the unit when the Key FOB is not present and additional settings management.



A keychain size Key FOB permits the user to remotely transmit various messages to the Tracker device within a range of 60 feet and acts as a beacon for the Tracker to automatically verify authorized/un-authorized movement of the property.

UNAUTHORIZED MOVEMENT

If the asset moves more than 500 meters without the user's authority and the key FOB is not present, unauthorized movement is detected and an alert is sent to a third party Asset Monitoring Center.

DAILY STATUS

Daily Status Message that includes Tracker ESN, power source status, Unauthorized Movement status, Vibration sensitivity, Tracker battery status, Sensor Alert status, GPS location, date and time and a link to Google Maps to see where your boat is located.

SENSOR ALERT

Notification from SPOT HUG wired connections for monitoring various additional accessory sensors on board the vessel. There are 4 (2 open and 2 closed) external contacts for sensor monitoring.

SENSOR ALERT BUNDLE

Provides 50 event messages for a bundled price for alarms delivered through the "dry contacts". A la carte "events" will be charged on a per event basis.

SPOT HUG BASIC SERVICE

Includes: Unauthorized Movement monitoring, Daily Status message and SPOT functionality of Check-in/OK, Help and SOS.

THE ASSET MONITORING CENTER

The service SPOT uses for monitoring Unauthorized Movement.

TRACKER

Unit that contains the GPS chip and satellite transmitter for sending messages from the SPOT HUG.

TRACKER MOUNTING BRACKET

Holds the Tracker. This is the equipment that will be attached to the boat.

KEY FOB

Wireless remote device that automatically Arms/Disarms SPOT HUG and can be used to activate SPOT functions of SOS, Help, Check-In/OK and Track Progress.

KEYPAD

The Keypad is mounted on the boat to control the SPOT HUG functionality in addition to or when the FOB is not present. Can also be used to activate SPOT functions of SOS, Help, Check-In/OK and Track Progress.

KEYPAD MOUNTING BRACKET

Holds the Keypad. This is the equipment that will be attached to the boat.

SOS

SOS alerts the GEOS International Emergency Rescue Coordination Center (IERCC) of your GPS location in a critical emergency.

HELP

Help sends a request for assistance to your designated contacts for non-life-threatening emergencies.

CHECK-IN/OK

Check-in/OK sends a pre-defined message with your GPS location to your designated contacts.

TRACK PROGRESS

Track Progress automatically updates your location on Google Maps™ allowing your contacts to track a virtual breadcrumb trail of your progress in near real-time.

PREDEFINED MESSAGE

A predefined Message is a message that has been created and saved in the user's account and can be sent with a variety of message modes. These messages are included with the Basic Service.

GEOS SEARCH & RESCUE INSURANCE

GEOS provide the SOS/911 monitoring included in your Basic Service. You can upgrade to the GEOS Member Benefit for reimbursement of up to \$100K in Search and Rescue (SAR) expenses - even coordinating a private SAR contractor if needed to get you to safety.

SPOT ASSIST MARITIME

SPOT Assist Maritime provides satellite-based notification to third party professional service providers to help ensure your safety on the water - at the push of a button.

SPOT LINK

To link a SPOT Assist Maritime Membership, we require a linkage fee to link the SPOT device to that service. This linkage fee allows the service provider access to receive direct location-based messages from your HELP button.

MESSAGE PRIORITY

The message modes in the SPOT HUG system are assigned to different priorities and some message modes will override others. Message modes are classified as Critical, Urgent and Casual.

- Critical – SOS and Unauthorized Movement
 - In general, Casual modes will be overridden by Urgent modes; which in turn will be overridden by Critical modes except when stated otherwise.
- Urgent – Help and Sensor Alert
- Casual – Check-in/OK, Track Progress, Daily Status and Power Source Switching

SPOT SATELLITE TECHNOLOGY

1. GPS satellites provide signals.
2. SPOT HUG Tracker's onboard GPS chip determines the asset's GPS location and sends the location information to communication satellites.
3. Communication satellites relay your message to specific satellite antennas around the world.
4. Satellite antennas and a global network route your location and message to the appropriate network.
5. Your location and messages are delivered according to your instructions via email, text message, or emergency notification to the GEOS International Emergency Response Coordination Center (IERCC).



UNAUTHORIZED MOVEMENT

1. Tracker detects boat vibrations waking up GPS in the SPOT HUG Tracker unit.
2. Tracker's onboard GPS chip determines the asset's GPS location.
3. Checks for FOB presence.
4. If no Key FOB is present and the Tracker has not been manually disarmed via the Keypad and the boat moves more than 500 meters from the original GPS position, an alert is sent to the Asset Monitoring Center.
5. Asset Monitoring Center will notify authorities of Unauthorized Movement.

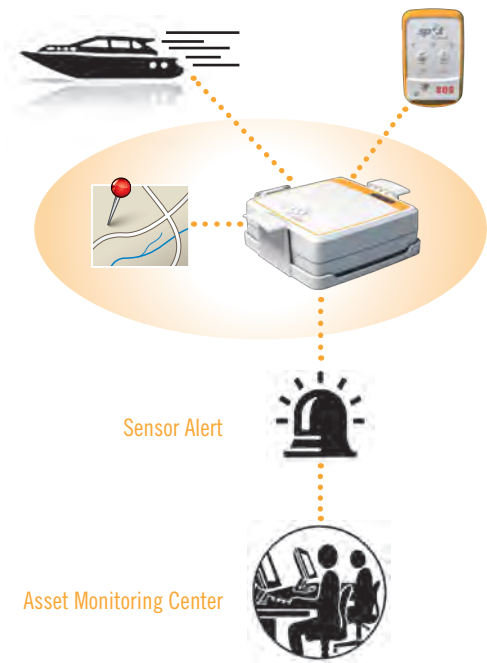

Please read through the user guide to familiarize yourself with the SPOT HUG contents, system set-up and usage.

HUG can be installed by the individual user or by a qualified marine electronics installer.

Service activation is required to begin using any of the HUG features. Visit findmeSPOT.com to activate or follow the procedures in the Service Activation section within this user guide.

PACKAGE CONTENTS

- One (1) Tracker
- One (1) Tracker mounting bracket
- One (1) Keypad (pre-paired with Tracker)
- One (1) Keypad mounting bracket
- Two (2) FOBs (pre-paired with Tracker)
- One (1) Adhesive tape for testing Tracker pre-installation
- One (1) Cable assembly (Line power cord - 18 gauge, 6 ft long; Pair of Sensor Alert wires – 20 gauge, 6 ft long)
- Eight (8) #6 - 3/8" stainless steel screws for plastic/fiberglass and sheet metal for Tracker and Keypad mounting brackets.
- One (1) 18" USB cable
- Four (4) AA lithium batteries for Tracker
- Four (4) CR2032 coin cell lithium batteries (2 for Keypad and 1 for each FOB)
- One (1) Quick Start Guide
- One (1) Quick Reference Guide (for Keypad)

WHAT TOOLS YOU'LL NEED FOR INSTALLATION

- Power drill
- Drill bits to fit #6 screws
- #1 screwdriver to remove and reattach battery compartments on Keypad and Tracker
- #2 Philips head screwdriver for mounting brackets
- Cable crimper (Note: All wires will have marine grade butt connectors size 22g-18g attached for easy crimping and attachment of accessory wires. Also, this provides built in protection for unused wires.)
- Wire cutter
- Socket wrench to remove bolts on 12V or 24V batteries

COMPONENT OVERVIEW

TRACKER

- A TRACKER MOUNTING BRACKET
- B TRACKER LEDs
- C SOS BUTTON
- D THIS SIDE UP LOGO
- E LINE POWER/SENSOR ALERT PORT



COMPONENT OVERVIEW

KEY FOB

- A KEY FOB BATTERY STATUS LED
- B GPS LED
- C TRACKER RANGE LED
- D TRACK PROGRESS BUTTON/LED
- E SOS LED
- F SOS BUTTON
- G HELP BUTTON
- H HELP LED
- I CHECK-IN/OK BUTTON/LED

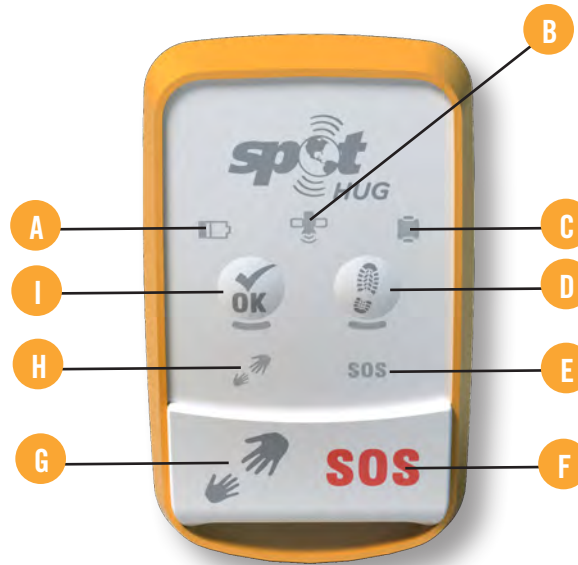

COMPONENT OVERVIEW

KEYPAD

- A** 1-0: 10 ALPHA NUMERIC KEYS
- B** GPS LED
- C** TRACKER BATTERY POWER LED
- D** MESSAGE SENDING LED
- E** TRACKING BUTTON/LED
- F** SOS LED
- G** SOS BUTTON
- H** HELP BUTTON
- I** HELP LED
- J** CHECK-IN/OK BUTTON/LED
- K** KAYPAD BATTERY POWER LED
- L** TRACKER RANGE LED

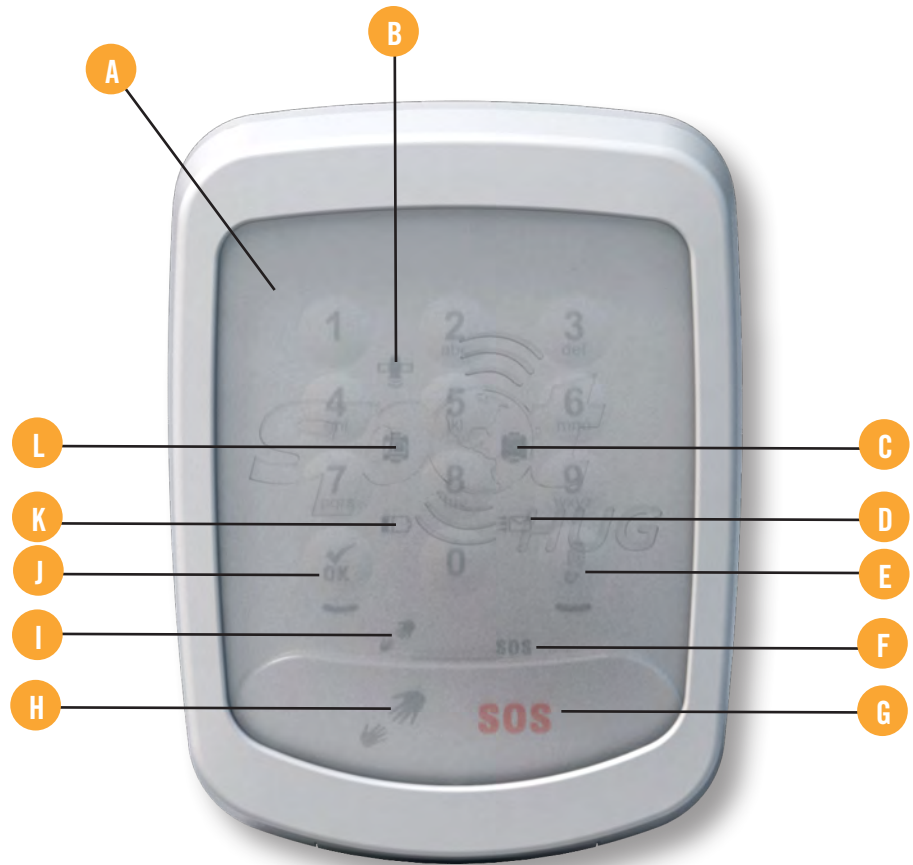

INSTALLING THE BATTERIES

INSTALLING THE BATTERIES ON THE KEY FOB

- Access the battery compartment by removing the 4 screws on the back plate of the FOB. Insert coin cell battery.
- Replace FOB cover and screw tightly for secure waterproofness.
- Repeat for second FOB.

INSTALLING THE BATTERIES ON THE KEYPAD

- Remove Keypad back plate cover using a small screwdriver to loosen the six screws.
- Insert the coin cell batteries into the Keypad.
- Replace the Keypad cover and screw all 6 screws tightly to ensure waterproofness.

INSTALLING THE BATTERIES ON THE TRACKER

- Loosen screws of the back plate of the Tracker and insert four AA Energizer Ultimate Lithium (L91) batteries. The batteries can be used if line power not connected or as a back-up if line power becomes unavailable. If battery mode is chosen, periodically check for the low battery indicator and replace batteries when required. See Care and Support section for battery life.
- The ESN (Electronic Serial Number) and Authentication code are printed in the battery compartment of the Tracker. Write down the ESN and Authentication code for use during the online activation process. Carefully seat the O-ring into place before replacing the cover. Tighten screws with a screwdriver. It is important to tighten the cover to keep the Tracker waterproof. Do not over tighten or you may damage the plastic.

SERVICE ACTIVATION

WHAT YOU NEED TO ACTIVATE YOUR ACCOUNT ONLINE

- Personal information
- Emergency contact information
- SMS (Text) and e-mail contacts for messaging.
Note: Customers activating service in North America will need to know the cellular service carrier of each contact that are entered in Message Profiles (E.g. ATT, Verizon, Rogers, etc.).
- Credit card information
- Tracker ESN and Authentication code. These numbers are found inside of the Tracker battery compartment.
- Details of property to be monitored

ACTIVATION

1. Visit findmeSPOT.com and click on "Activate Your SPOT".
2. Choose set up New Account or sign in to your existing account to add HUG to your list of devices.
3. For New customers you will need to create an account. Complete the required fields and then click "Next".
4. Complete the "About You" section and click "Next".
5. Select services, HUG Basic Service and additional services such as Sensor Alert Bundle and Track Progress.
6. Enter your Emergency contact info, including the Name, Country and Phone number for your Primary and Secondary Emergency Contacts. Please note that these contacts must be different from those provided in the previous Billing information section.
7. You will also need to enter contact information if an Unauthorized Movement situation occurs as the Asset Monitoring Center will need to validate the alert. This could be yourself and an additional contact.
8. Payment will then be requested.

MY SPOT DEVICES

1. Once you have activated your HUG unit, you can come back at any time and edit your device settings on the My SPOT Devices tab. Choose the HUG unit and click on View/Edit under Contact Details. Complete this section to ensure that contact information is accurate.
2. When entering contact information, add your own email or phone number to Check-in/OK contact list for use in the system test. This can be changed at a later time.
3. Be sure to complete the fields describing your boat in the Additional Information section to assist authorities in recovery efforts.
4. If Sensor Alerts are to be used to monitor additional boat equipment, click the Sensor Alert Tab. You will need to assign a sensor from the drop down list and add contacts who will receive the Sensor Alerts.

PURCHASE SENSOR ALERTS

To monitor additional onboard statuses, such as high water, low battery, cabin door, motor theft or power status, purchase the Sensor Alert Bundle at findmeSPOT.com. (Note: Sensor Alerts can be purchased on an a la Carte basis also.)

KEEPING YOUR CONTACTS IN TOUCH

Up to 10 contacts can be added for receipt of your Check-in/OK, and Help messages, and you can update these at any time on the website by logging in to your account. You can specify any combination of text/SMS messages or email for the contacts.

Unauthorized Movement messages will be sent to the Asset Monitoring Center. Contacts you designate will be called and notified of the situation.

SOS messages will go to the GEOS International Emergency Rescue Coordination Center. In the event of an SOS message, GEOS will attempt to contact your primary and secondary emergency contacts. These contacts are required in order to activate your account. You can change these at any time under the SOS section at findmeSPOT.com.

Current SPOT HUG map coverage can be found at findmeSPOT.com. The Tracker's satellite message transmission is independent of mobile phone or other land-based radio coverage.

ADDITIONAL SERVICES

At findmeSPOT.com you can also purchase additional service options either at activation or anytime you go back to the site.

SENSOR ALERT BUNDLE

Provides 50 event messages for a bundled price for alarms delivered through the "dry contacts". A la Carte "events" will be charged on a per event basis.

TRACK PROGRESS

Track Progress automatically updates your location on Google Maps™ allowing your contacts to track a virtual breadcrumb trail of your progress in near real-time.

GEOS SEARCH & RESCUE INSURANCE

GEOS provide the SOS/911 monitoring included in your Basic Service. You can upgrade to the GEOS Member Benefit for reimbursement of up to \$100K in Search and Rescue (SAR) expenses - even coordinating a private SAR contractor if needed to get you to safety.

SPOT ASSIST FOR MARITIME

SPOT Assist Maritime provides satellite-based notification to third party professional service providers to help ensure your safety on the water - at the push of a button.

TRACKER SYSTEM SETUP

Before installing the Tracker and mounting the Keypad in their permanent locations, it is necessary to ensure all components are working properly. You must have activated your SPOT HUG account to perform the system setup/test. The Tracker comes from the factory paired with the Keypad and 2 Key FOBs.

1. Set up all three units (Tracker, Keypad, and FOB) together in a clear line of sight to the sky. Ensure the Tracker unit is facing up.
2. For the system test, the Tracker, Keypad and FOBs should be close together in order to view the blinking lights and synchronization of the devices.
3. Install batteries in each unit. When the batteries have been installed, the Tracker will perform a self-test of the GPS receiver and satellite transmitter and will check battery power. The On/Off LED will blink green if the Tracker passes the self-test.
4. Next, the Keypad LEDs will blink red in a pattern to indicate that a PIN (Personal Identification Number) must be setup. See page 6 for full instructions. Note the PIN for future reference.
5. Press Check-in/OK on the Keypad for 3 seconds until you hear an audio beep. The Tracker will blink its GPS LED for up to 4 minutes while it acquires a GPS fix.
6. If a GPS signal cannot be acquired, the GPS LED on the Tracker will blink red. Move to a better location where the view to the sky is unobstructed.
7. If the GPS LED stops blinking before a good location is found, remove and re-install batteries and repeat the test.
8. Check that a Check-in/OK message is received at the end of the setup.
9. If all three LEDs blink red, the self-test failed. Please call Customer Care at 1-866-OK1-SPOT (1-866-651-7768).

KEYPAD SYSTEM SETUP

After installing the coin size Lithium batteries, the Keypad will perform a self-test. The self test checks for battery level, and the presence of the Tracker and Key FOB. When the presence of the FOB and Tracker are confirmed, the Keypad then performs a system check to identify if it is correctly paired to the Tracker.

BATTERY SELF TEST

1. Make sure the Keypad, Tracker and FOB are within close proximity (3 ft/1.5 m)
2. Install batteries. If Keypad battery level is low, the Keypad battery LED will blink red. Batteries should be replaced immediately.

SYSTEM TEST AND SETTING PIN

1. The Keypad will check for presence of the Tracker. If the Tracker is present the Tracker Range LED blinks green every 3 seconds for the first minute. If the Tracker is NOT present the Tracker Range LED blinks red and the Keypad should be moved closer to the Tracker.
2. When using the Keypad for the first time, you must change the default PIN. The default PIN for your Keypad is the last 4 digits of your "Auth" code, located in the Tracker battery compartment. This PIN is required to de-activate alarms, and program Tracker messages.
3. To set the PIN, you will need the last 4 digits of the Tracker Auth Code, located in the Tracker battery compartment. With at least 1 FOB in range, press the number 4 on the Keypad, and then Check-in/OK. Enter the last 4 digits of the Auth Code and then press Check-in/OK again. Choose a personal PIN that you can remember. Enter the new Personal PIN number, followed by pressing Check-in/OK. Repeat once more to confirm that the new PIN was entered correctly by pressing the new PIN number and then Check-in/OK. There will be audio visual feedback to confirm positive acceptance. Refer to quick reference card or the Keypad Functions section. After the PIN is entered correctly the second time, the new PIN goes into effect. Write down the new PIN code and store in a safe place. A PIN reset cannot be performed when there is no Key FOB present. The Tracker will broadcast the PIN notification messages to all FOBs for the next five (5) minutes; it is imperative for all FOBs that need to be paired be within range of the Tracker during the broadcast period. Any FOB not present during the PIN change will become unpaired and will need to be re-paired in order to function.

NOTE: The Keypad can be used to administer the SPOT HUG settings.

There are 3 settings for vibration sensitivity on the Tracker: low (1), medium (2), and high (3). Low is considered ideal for less than a 30 ft boat. High, for a large 30 ft or greater boat. If in doubt on vibration sensitivity settings for your boat, set it to medium.

To change the vibration sensitivity setting on the Tracker, press the number 12 on the Keypad, and then Check-in/OK. Press 1 = low, 2 = medium or 3 = high. Follow by pressing Check-in/OK.

KEY FOB SYSTEM SETUP

The Key FOB device system test is similar to the Keypad.

1. When batteries are inserted, the FOB performs a self test to check battery level and presence of the Tracker.
2. If the FOB successfully establishes a connection to the Tracker, the Tracker Range LED blinks green for 1 minute.
3. If the Tracker is not present the FOB Tracker Range LED blinks red every 3 seconds for 1 minute. You must move closer to the Tracker unit to establish a connection.

If the FOB is lost/stolen or you will need to deactivate the remaining FOBs for security reasons. Perform the following steps:

1. Bring remaining FOBs into range of the Tracker (within 60 ft).
2. Change PIN on Keypad. This will deactivate the lost/stolen FOB and reset the pairing on the remaining FOB.
3. If all FOBs are lost/stolen, enter PIN on Keypad and turn off “arm” state OR remove power from Tracker.
4. Order replacement FOBs from findmeSPOT.com

SEND A TEST CHECK-IN/OK MESSAGE

SPOT HUG recommends testing the Check-in/OK during the initial system set-up, on occasion and before every trip to ensure messages are sent and delivered properly. Before sending your first Check-in/OK message, synchronization of the Keypad and Key FOB devices with the Tracker are required. Follow directions in the FOB and Keypad System Test sections.

For first time set-up, the Test Check-in/OK Message is to be completed after passing the self-test.

1. For the initial Test Message, ensure the Tracker unit has a clear view of the sky and with the arrow logo pointing upward.
2. To send a message, press the Check-in/OK button on the FOB or the Keypad. The GPS indicator LED on the FOB and Keypad blink green as the Tracker acquires a GPS fix.
3. Once the Tracker acquires your GPS location, the Message Sending LED and GPS LED on the Keypad will blink green in unison for ~15 seconds to notify you that your message is being transmitted with GPS location. The GPS LED on the FOB will blink green for 15 seconds. The Message Sending LED on the Keypad will continue to blink green over the remainder of the 20-minute message cycle and for one (1) hour after the end of the message cycle. The Check-in/OK function LED will turn off once the message cycle is complete.
4. If the GPS LED blinks red, the Tracker does not have a clear view of the GPS satellites and you must move to an area with a clearer view of the sky for proper operation. Once you move to an area with clearer view of the sky, repeat steps 1 through 4.
5. Verify that the message was received in the email or SMS account(s) that were set up during activation in your Check-in/OK contact list. You can also view your messages in your account at findmeSPOT.com.

INSTALLATION OF TRACKER

Once all three units are operational and provisioned after verifying the Check-in/OK messages have been delivered correctly, they can be placed in their desired permanent locations. For permanent installations, ensure the appropriate connectors (screws...etc.) are used to avoid any damage to the vessel.

Although it is recommended to install the tracker in a concealed location, it should also be located in a place where the user can push the SOS button if required. Consider placement of the Tracker where the pitch and roll of the vessel is at a minimum.

NOTE: Since SPOT HUG is a theft prevention device and needs to be hidden from plain sight, it is important to note that the HUG Tracker unit be installed under an RF transparent material (e.g. fiberglass, wood, plastic less than 3 inches thick) and with the antenna facing up to the sky (logo side). The arrow logo on the side of the Tracker must be mounted in a position where the arrow is facing up in order to receive GPS signals and send satellite messages with optimal efficiency. The Tracker should be installed away from any satellite interference mediums, such as metallic objects and other transmitters such as Wi-Fi or other RF devices. HUG devices should be at least 12 inches away from other GPS and electronic devices.

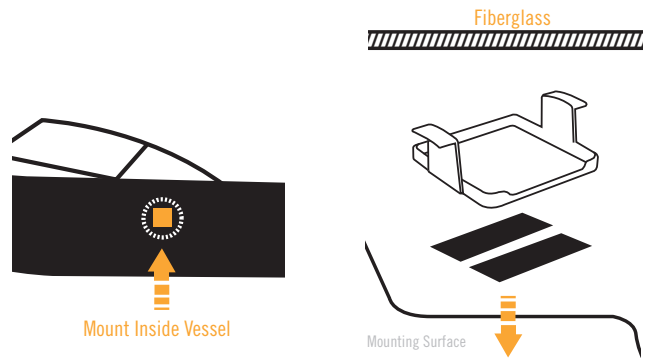

1. Line power should be able to reach the Tracker with the included power cable (6 ft/1.8m). Use the double-sided adhesive tape for temporary mounting of the Tracker during the testing phase. Simply place the tape on the bottom of the Tracker mounting bracket and stick it to your installation surface.

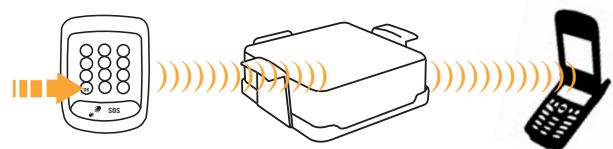

2. Test the unit to ensure it can receive GPS signals and transmit messages from the selected location by pressing the Check-in/OK button so that the Check-in/OK message is sent to the desired chosen location, such as an SMS to your mobile phone.

3. Remove the Tracker mounting bracket, included, and mark the four holes with a pencil before drilling the holes into the surface. Carefully align the mounting bracket where the holes are marked and use a screwdriver to fasten the four screws onto the surface. As an option to using screws, tie wraps can be used in the four corner holes on the Tracker. Be sure that the Tracker is mounted securely and the satellite arrow logo remains pointing to the sky at all times.

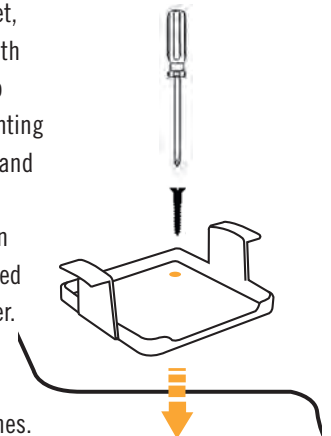

4. Slide the Tracker unit into the Tracker mounting bracket.
5. Attach optional line power to a 12 V or 24 V battery.

INSTALLATION OF TRACKER WITH SENSOR ALERTS

Each SPOT HUG Tracker comes with four (4) Sensor Alert inputs. These Sensor Alert wires can be attached to sensor devices in order to monitor high water, battery level, door opening/closing, and other equipment that the user chooses. Sensor devices are not included with HUG but are available as accessories at marine electronics dealers and findmeSPOT.com. An additional fee is required to receive alert messages from any monitored equipment.

1. Ensure the monitored device is within the voltage range of: 9.7-37.0 volts.
2. Remove appropriate fuses in the device to be monitored to avoid potential damage to equipment and electrical shock.
3. If using Sensor Alerts, place the Tracker where the weatherproof Sensor Alert wires can be easily accessible. Follow the sensor manufacturer's wire length and application specifications.
4. Attach the Sensor Alert wire to the appropriate contact and seal the cable opening with the provided o-ring to prevent water intrusion.

To accommodate as many sensors as possible, HUG can operate with accessories that require "OPEN" or "CLOSED" circuits.

CONTACT TYPE	DESCRIPTION AND USE
<p>OPEN Sensor Alert 1 Orange and Orange/White wires, and Sensor Alert 3, Violet and Violet/White wires (wires with white are grounds)</p>	<p>An OPEN contact doesn't have electrical voltage passing through until a relay circuit is made. When the Tracker senses an electrical voltage, the OPEN Sensor Alert is activated, and the notification to the contacts commences. Below are application examples:</p> <ul style="list-style-type: none"> • High Water monitoring • Low battery voltage
<p>CLOSED: Sensor Alert 2 Green and Green/White wires, and Sensor Alert 4, Blue and Blue/White (wires with white are grounds)</p>	<p>A CLOSED contact requires a steady minimum voltage passing to the sensor so that if the circuit is broken, the notification to the contacts commences. There will be a 30 second delay before sending the CLOSED contact message. Here are some examples of applications where this can be used:</p> <ul style="list-style-type: none"> • Cabin door monitoring. When door opens, the circuit is broken. • Anti-motor theft • Power Monitoring. When power to cabin is off, the circuits break.

INSTALLATION OF KEYPAD

The Keypad is the device required to activate the Key FOB during the initial setup phase. For security, the user is required to change the factory default PIN before use (A step covered previously in the Keypad System/Test section).

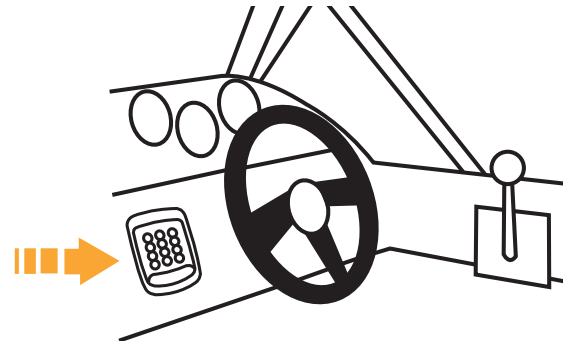

1. Locate a place where the Keypad can be mounted inside the cabin. The Keypad needs to be within 60 feet/18 meters of the Tracker. Tracker Range can be checked with a quick press of the Check-in/OK button on the Keypad. If the Tracker Range LED blinks green the Keypad is within range of the Tracker. It is recommended the Keypad unit be placed in a sheltered environment from weather elements or extreme temperatures.
2. Remove the Keypad mounting bracket and mark the four holes with a pencil before drilling the holes into the surface. Carefully align the mounting plate where the holes are marked and use a screwdriver to fasten the four screws onto the surface.
3. If using double-sided adhesive mounting tape, remove the double adhesive protective paper and place the adhesive pad in the center of the back mounting plate. Clean the surface of the area where the Keypad is going to be mounted. Firmly press the Keypad mounting bracket with the adhesive pad to the area.
4. After the Keypad mounting bracket is secured in place, attach the Keypad by sliding the back into the cleat of the mounting bracket.

SPOT HUG ALERT NOTIFICATIONS

ARMING AND DISARMING HUG FOR UNAUTHORIZED MOVEMENT

THE SPOT HUG will be automatically armed once the Key FOB has left the Tracker range (60 ft/18m). HUG will be automatically disarmed and remain disarmed when a paired FOB comes into and stays within Tracker range. The Tracker frequently checks for the presence of the paired FOB to ensure security.

Without the FOB present, to arm the Tracker, press the number “01” on the keypad and then press Check-in/OK. Enter the PIN number and press Check-in/OK. If successful, there will be one solid beep and 1 solid green blink on the Check-in/OK LED. If unsuccessful, there will be 3 beeps, with 3 green blinks on the Check-in/OK LED.

Without the FOB present, to disarm the Tracker, press the number “00” on the keypad and then press Check-in/OK. Enter the PIN number and press Check-in/OK. If successful, there will be one solid beep and 1 solid green blink on the Check-in/OK LED. If unsuccessful, there will be 3 beeps, with 3 green blinks on the Check-in/OK LED.

UNAUTHORIZED MOVEMENT ALERT NOTIFICATION (SENDS MESSAGE)

When there is Unauthorized Movement of the boat, beyond 1640 feet/500 meters of the original location with no FOB in range of the Tracker or no PIN entry on the keypad to disarm the alarms, the process to send a satellite message noting Unauthorized Movement begins. The GPS receiver acquires the GPS position then transmits an Unauthorized Movement alert message via satellite to the Asset Monitoring Center. The alert messages will be sent in 5-minute intervals until the asset stops moving. Once the asset has stopped moving the transmission intervals will decrease to every 30 minutes to conserve batteries and once per day if no GPS fix can be found after 4 consecutive attempts. If a correctly paired FOB becomes present or the user deactivates the alarm on the Keypad, the Tracker will send a cancel Unauthorized Movement message. The Tracker will then continue to look for the presence of a FOB and monitor accordingly.

SENSOR ALERT NOTIFICATIONS

If a Sensor Alert is activated by the external device (i.e. high water alarm, cabin door alarm, low battery voltage, etc.), a message containing the GPS position and Sensor Alert name is transmitted via satellite.

- If the FOB is present the Sensor Alerts will automatically be turned off.
- Sensor Alert notifications are sent every 5 minutes for 1 hour. Messages are then included with the Daily status message. Configure your designated recipients at findmeSPOT.com to receive Sensor Alert messages via e-mail or SOS.
- Disarming the Sensor Alerts can also be completed via the Keypad.
- The first Sensor Alert message will be sent within 1 minute regardless of GPS acquisition.
- If the Alarm condition transition back to Normal state, the Sensor Alert message will be sent for a total of 5 times before a Sensor Alert Cancel message is sent.

When the Tracker is in the process of sending the Sensor Alert messages the Tracker overrides the Check-in/OK or Track Progress button press. The Tracker only responds to the pressing of the SOS or Help buttons. In addition, the Sensor Alert message overrides the Daily Status message transmission.

DAILY STATUS MESSAGE





A daily status notification message is sent to the user and selected recipients based on the user profile on findmeSPOT.com.

Daily Status message includes:

- Tracker ESN, power source status, Unauthorized Movement status, Tracker battery status, Sensor Alert status, GPS location, date and time and a link to Google Maps to see where your boat is located.
- The message will be sent every 24 hours.
- Messages are stored in the user's account for a minimum of 30 days and in the Shared Pages for at least 7 days.

NOTE: Key FOB must be paired with and within range of Tracker to use SPOT functionality. Keypad may also be used.

TYPES OF MESSAGES ACTIVATED BY USER (FOB AND KEYPAD)

FUNCTION	OVERVIEW
 SOS	<ul style="list-style-type: none">- Alert emergency responders to your GPS location.- SOS is considered a critical message type and overrides all other messages. When SOS is pressed, it overrides Check-in/OK, Help and Track Progress. <p>NOTE: To be used in emergency situations. You may be liable for the cost of your rescue.</p>
 HELP/SPOT ASSIST	<ul style="list-style-type: none">- Request help from your friends and family at your GPS location, or ask for help from professional assistance organizations instead of friends and family.- If GPS cannot be determined when Help button is pressed, the device will continue to look for a GPS location and send when it gets a GPS fix.- Help is considered an urgent mode. When Help is pressed, it overrides Check-in/OK, and Track Progress.
 CHECK-IN/OK	<ul style="list-style-type: none">- Let contacts know where you are and that you're okay with a preprogrammed message.- Check-in/OK is a casual message mode. If a GPS location is not found, this message is not sent.
 TRACK PROGRESS	<ul style="list-style-type: none">- Automatically send and save your location and allow contacts to track your progress using Google Maps.™- Once engaged, sent every 10 minutes for 24 hours or until canceled. With each message SPOT will included your GPS location for 2 previous track positions for a seamlessly reliable breadcrumb trail.- Track Progress is a casual message mode. If a GPS location is not found, this message is not sent, but it will try again at the next scheduled interval.

SOS SOS (FOB/KEYPAD/TRACKER)

NOTE: To be used in emergency situations. You may be liable for the cost of your rescue.

For life-threatening or other critical situations, alert the GEOS International Emergency Rescue Coordination Center (IERCC). GEOS notifies the appropriate emergency responders based on your location and personal information – which may include the Coast Guard, local police, highway patrol, your country's embassy or consulate, other emergency response centers, or search & rescue teams.

MESSAGE CYCLE

HUG sends your emergency profile information and current GPS location to GEOS every 5 minutes until canceled or the Tracker batteries run out. If SPOT HUG cannot get a GPS signal, it will still attempt to send your message – without a GPS location. There is no test mode. If you activate the SOS function, the GEOS International Emergency Response Coordination Center will treat it as a real emergency.

USING THE SOS FUNCTION

Press and hold the SOS button until it blinks green. The GPS LED will blink green when HUG sees the GPS satellites and while obtaining your GPS location.

Once your GPS location is obtained, HUG sends your message and GPS location. The GPS LED and Message Sending LED, Keypad only, will both blink green for approximately 15 seconds. The Message Sending LED on the Keypad continues to blink green until the next scheduled message to notify you that your most recent message was transmitted.

If no GPS signal is found, the GPS LED will blink red. Move the vessel to an area with a clearer view of the sky.

The first message will be sent within (1) minute after activation with or without your GPS location. For all subsequent messages, HUG will keep looking for your GPS location for up to 4 minutes. If no GPS location is found in 4 minutes, HUG sends your message without GPS location. The GPS LED blinks red and the Message Sending LED blinks green for approximately 15 seconds. The Message Sending LED will continue blinking green until the next scheduled message.

TO CANCEL

Press and hold the button on the device that was used to initiate the SOS until it blinks red. Let HUG work until the SOS button stops blinking red. The Message Sending LED on the Keypad will blink green indicating it has sent the Cancel message.

HOW HUG PRIORITIZES SOS

SOS messages are the top priority for HUG. When you select Help/SPOT Assist or SOS, you will disable Check-in/OK, and Track Progress functions.



HELP/SPOT ASSIST (FOB/KEYPAD)

For non-life threatening situations, ask for help from friends and family or professional assistance providers using SPOT Assist. Your contacts will receive SMS/text or email messages with your GPS coordinates. Email messages also include a link to view your location using Google Maps™. SPOT Assist service partners will receive your SPOT Assist message and current GPS location.

MESSAGE CYCLE

HUG will send your message and current GPS location every 5 minutes for an hour for redundancy and overall reliability. If HUG cannot get a GPS signal, it will still attempt to send your message – without a GPS location.

USING THE HELP FUNCTION

Press and hold the Help button on the Key FOB or Keypad until the function button blinks green. The GPS LED will blink green when HUG sees the GPS satellites and continue for up to 4 minutes while obtaining your GPS location.

Once your GPS location is obtained, HUG will send your message with GPS location. The GPS LED and Message Sending LED on the Keypad will both blink green and the GPS LED will blink green on the FOB for approximately 15 seconds. The Message Sending LED on the Keypad continues to blink green until the next scheduled message or until one (1) hour after the end of the message cycle to notify you that your most recent message was transmitted.

If no GPS signal is found, the GPS LED will blink red. Move the vessel to an area with a clearer view of the sky. HUG will keep looking for your GPS location for up to 4 minutes.

If no GPS location is found in 4 minutes, HUG sends your message without GPS location. The GPS LED blinks red on the FOB and Keypad and the Message Sending LED, Keypad only, blinks green together for approximately 15 seconds. The Message Sending LED will continue blinking until the next scheduled message or until one (1) hour after the end of the message cycle.

The Message Sending LED on the Keypad continues to blink for one (1) hour after the end of the Help/SPOT Assist message cycle to give you additional time to verify the status of your most recent message.

TO CANCEL

Press and hold the Help button until it blinks red. Let HUG work until the Help button stops blinking red. The Message Sending LED on the Keypad will blink green indicating it has sent the Cancel message.

HOW HUG PRIORITIZES HELP

Help/SPOT Assist messages are a priority for HUG. When you select Help/SPOT Assist or SOS, you will disable Check-in/OK, and Track Progress functions. You will be able to activate Combined Help and SOS mode. If you have signed up for SPOT Assist, SPOT Assist will not be available, but Help messages will still be transmitted to designated friends & family.



CHECK-IN/OK (FOB/KEYPAD)

Let your contacts know where you are and how you're doing; or mark a single waypoint to review later. Your contacts will receive SMS/text or email messages with your GPS coordinates. Email messages also include a link to view your location using Google Maps™.

MESSAGE CYCLE FOR CHECK-IN/OK

The Tracker will send your message and GPS location to the SPOT HUG network three times over 20 minutes for maximum reliability (only one email or SMS/text message will actually be sent to your contacts). If HUG cannot get a GPS signal, it will not send your Check-in/OK.

USING THE CHECK-IN/OK FUNCTION

Press and hold the Check-in/OK on the Key FOB or Keypad until the button blinks green. The GPS LED on the FOB or Keypad will blink green when HUG sees the GPS satellites and continue while obtaining your GPS location.

Once your GPS location is obtained, HUG sends your message and GPS location. The GPS LED and Message Sending LED, Keypad only, will both blink green for approximately 15 seconds. The Message Sending LED on the Keypad continues to blink green after it transmits the most recent message and for one (1) hour after the end of the message cycle. Let HUG work until the end of the message cycle when the Check-in/OK Message LED stops blinking.

If no GPS signal is found, the GPS LED will blink red. Move the vessel to an area with a clearer view of the sky. HUG will keep looking for your GPS location for up to 15 minutes.

If no GPS location is found in 15 minutes, HUG does not send your message. To try again, simply press and hold the function button. The Message Sending LED on the Keypad will blink red for one (1) hour after completion of the message cycle to notify you that your message was not transmitted.

The Message Sending LED on the Keypad continues to blink for one (1) hour after the end of the message cycle to give you additional time to verify the status of your Check-in/OK. In a hurry? You can dismiss the LED by activating any other function.

TO CANCEL

All Check-in/OK messages are sent providing a GPS location is found.

HOW HUG PRIORITIZES CHECK-IN/OK

Check-in/OK are the lowest priority HUG messages – if you press the Help, Track Progress, or SOS buttons while in Check-in/OK Message mode, HUG will cancel any unsent Check-in/OK Message and begin sending Help/SPOT Assist, Track Progress or SOS messages.

QUICK CHECK

You can send a Check-in/OK while you're in Tracking. If Tracking is active, it will be suspended long enough to send the Check-in/OK, then resume once the Check-in/OK cycle is complete. This lets you easily update your contacts of your whereabouts while in Tracking. For example, if you'd like to send an "okay" message at the start of a trip to let your friends know to follow your whereabouts on SPOT Adventures or findmeSPOT.com, simply start Track Progress, and then press "Check-in/OK". HUG will send a Check-in/OK message then continue tracking.



TRACK PROGRESS

Send your location to allow contacts to track your progress in near real-time using Google Maps™ or SPOT Adventures, giving them a virtual breadcrumb trail of your remote travel. Also automatically mark your waypoints to review later. Your contacts can see your progress on the web links that you create in your SPOT HUG account. Additional service fees may apply. See account information at findmeSPOT.com to learn more.

MESSAGE CYCLE

Track Progress messages are sent every 10 minutes for 24 hours or until canceled. You can re-engage Track Progress at any time to restart the cycle. With each message, HUG will include your GPS location for the 2 previous track positions for a seamlessly reliable breadcrumb trail. If HUG cannot get a GPS signal, it will not send your message, but will try again at the next scheduled interval.

USING THE TRACK PROGRESS FUNCTION

Press and hold the Track Progress button on the Key FOB or Keypad until it blinks green. The GPS LED will blink green when HUG sees the GPS satellites and while obtaining your GPS location.

Once your GPS location is obtained, HUG will send your waypoint. The GPS LED and Message Sending LED, Keypad only, will both blink green for approximately 15 seconds. The Message Sending, Keypad only, LED continues to blink green until the next scheduled message or until one (1) hour after the end of the message cycle to notify you that your most recent message was transmitted.

If no GPS signal is found, the GPS LED will blink red. Move the vessel to an area with a clearer view of the sky. HUG will keep looking for your GPS location for up to 4 minutes.

If no GPS location is found in 4 minutes, HUG will not send this particular waypoint. Both the GPS LED and the Message Sending LED, Keypad only, will blink red for approximately 15 seconds. HUG will rest for up to 6 minutes and try again at the time of the next scheduled message. The Message Sending LED will continue blinking until the next scheduled message or until one (1) hour after the end of the message cycle. The Message Sending LED continues to blink for one (1) hour after the end of the Track Progress message cycle to give you additional time to verify the status of your most recent message.

TO CANCEL

Press and hold the button on the device that was used to initiate the Track Progress until it blinks red.

HOW HUG PRIORITIZES TRACK PROGRESS MESSAGES

Help and SOS are prioritized over Track Progress – if you press the Help or SOS buttons while tracking, HUG will cancel any unsent messages and begin sending Help SPOT Assist or SOS messages. Track Progress is prioritized over Check-in/OK. If you are in Check-in/OK mode and press Track Progress, it will start tracking and cancel your unsent Check-in/OK.

QUICK CHECK

You can send a Check-in/OK while you're in Tracking. If Tracking is active, it will be suspended long enough to send the Check-in/OK, then resume once the Check-in/OK cycle is complete. This lets you easily update your contacts of your whereabouts while in tracking. For example, if you'd like to send an "okay" message at the start of a trip to let your friends know to follow your whereabouts on findmeSPOT.com, simply start Track Progress, and then press Check-in/OK. HUG will send a Check-in/OK message then continue tracking.

BY FUNCTION FOR TRACKER, KEY FOB/KEYPAD

LED	LED ACTIVITY	GREEN	RED
Power	When connected to line power	Solid	
	When using batteries only	Blinking	
	If GPS or satellite transmitter self-test fail		Power/GPS/SOS all blink red
	If battery power is low		Blinking
GPS	GPS fix	Blinking	
	No GPS fix		Blinking
	If GPS or satellite transmitter self-test fail		Power/GPS/SOS all blink red
SOS	When SOS is sent	Blinking	
	If GPS or satellite transmitter self-test fail		Power/GPS/SOS all blink red

IF TRACKER FINDS YOUR GPS LOCATION (KEYPAD AND KEY FOB)

FUNCTION	MESSAGE FUNCTION LED	GPS LED	MESSAGES SENDING LED (Keypad only)	MESSAGE STATUS
Check-in/OK	Function LED blinks green until the message cycle is completed or canceled	GPS LED blinks green	Blinks green after transmitting the most recent message as appropriate for each function and for one (1) hour after the message cycle ends	Message and location transmitted to the satellites
Track Progress				
Help/SPOT Assist				
SOS Emergency				

IMPORTANT NOTES

1. The blinking green LED within each function button lets you know you have successfully engaged that function.
2. After you engage the function, HUG looks for a GPS signal and location as indicated.
3. Once the GPS location is obtained, HUG sends your message and the GPS and Message Sending LEDs blink green together for 15 seconds, indicating a successful GPS fix and starting the message sending cycle.

**IF TRACKER DOESN'T FIND YOUR GPS LOCATION.
IT IS IMPORTANT TO TEST THE TRACKER UNIT BEFORE PERMANENT INSTALLATION.**

FUNCTION	FUNCTION BUTTON LED	GPS LED	MESSAGES SENDING LED (Keypad only)	MESSAGE STATUS	TO TRY AGAIN
SOS	Blinks Green	Blinks Red. Tracker looks for GPS for 4 minutes then rests for 1 minute.	Blinks Green	Message Sent without GPS	Move the vessel to an area with a clearer view of the sky. HUG will try to get a GPS location during the next message interval.
Help/Assist	Blinks Green	Blinks Red. Tracker looks for GPS for 4 minutes then rests for 1 minute.	Blinks Green	Message Sent without GPS	Move the vessel to an area with a clearer view of the sky. HUG will try to get a GPS location during the next message interval.
Check-in/OK	Blinks Green	Blinks Red	Blinks Red	Message not sent	Move the vessel to an area with a clearer view of the sky. Press the selected function again.
Track Progress	Blinks Green	Blinks Red. Tracker looks for GPS for every 4 minutes then rests for 6 minutes.	Blinks Red	Message not sent	Move the vessel to an area with a clearer view of the sky. HUG will try to get a GPS location during the next message interval.

IMPORTANT NOTES

CHECK-IN/OK: HUG must get a GPS signal before sending Check-in/OK Message. If no GPS signal is found, the GPS LED blinks red and SPOT HUG de-activates the function without sending any messages.

TRACK PROGRESS: HUG must get a GPS signal before sending your waypoint. However, HUG will stay in the Track Progress function, and again look for a GPS signal at the next scheduled message interval.

HELP/SPOT ASSIST: Tracker sends Help/SPOT Assist messages even without a GPS location. Tracker will again look for a GPS signal prior to sending the next scheduled message (~4-5 minutes), and repeat the entire message cycle.

SOS: Tracker sends SOS Emergency messages even without a GPS location. Tracker will again look for a GPS signal prior to sending the next scheduled message (~4-5 minutes after the first message), and repeat the entire message cycle.

BY STATUS FOR KEY FOB, KEYPAD AND TRACKER

STATUS LED	GREEN	RED
Tracker Range	Fob/Keypad TR LED blinks green if FOB is within 60 ft	Fob/Keypad TR LED Blinks red when out of range
Tracker Power Status (ON/OFF on the Tracker)	Solid green when it is line powered; Slow blink green when battery powered.	Blinks red when batteries are running low.
Tracker Power Status (Battery icon on Keypad)		Blinks red when batteries are running low.
FOB/Keypad Power Status		Battery LED blinks red when low battery
FOB/Keypad... Check-in/OK and Help cannot be activated while canceling Unauthorized Movement or Sensor Alert		Check-in/OK or Help LED will blink red for 3 seconds.

IMPORTANT NOTES

1. A quick press of Check-in/OK on the FOB or Keypad will be required to confirm Tracker Range and Message status.
2. SPOT HUG recommends when low battery indicator comes on, it is best to replace batteries immediately. When on a trip, always have a spare set of batteries for the FOB/Keypad and the Tracker.
3. If unsure if batteries are brand new, do not place them into any of the three HUG devices.
4. All LED activities on Keypad/FOB time out after 1 min.

The Keypad can be used to manually arm/disarm SPOT HUG. It is also used to turn on/off the GPS information in the daily status message, change PIN, pair additional Key FOBs and to enable/disable sensor alerts. Finally it can also be used to initiate and cancel SPOT modes.

- Press and release button unless specified otherwise
- After pressing Check-in/Ok, audio and visual feedback confirms successful or unsuccessful entries

AUDIO FEEDBACK

- Successful – solid beep; Unsuccessful – 3 beeps

VISUAL FEEDBACK

- Successful – single green blink on Check-in/OK LED; Unsuccessful – 3 green blinks on Check-in/OK LED

KEY PAD FUNCTION	ENTER NUMBERS		PRESS CHECK-IN/OK		ADDITIONAL DIRECTIONS
Theft Recovery Mode Off	00	+	✓ OK	+	Enter PIN press Check-in/OK
Theft Recovery Mode On	01	+	✓ OK	+	Enter PIN press Check-in/OK
Daily Status Off	02	+	✓ OK	+	Enter PIN press Check-in/OK
Daily Status On	03	+	✓ OK	+	Enter PIN press Check-in/OK
PIN Change (or setup)	04	+	✓ OK	+	1. Enter PIN (or enter default PIN, which is the last 4 digits of Authorization code, for initial setup only) 2. Press Check-in/OK 3. Enter new PIN followed by Check-in/OK 4. Enter new PIN again followed by Check-in/OK 5. Quick Press Check-in/OK on each FOB
Pair FOBs	05	+	✓ OK	+	1. Enter PIN 2. Press Check-in/OK 3. One FOB at a time, press Check-in/OK and Track Buttons on Fob simultaneously for 3 seconds 4. Repeat #7 & 8 for all FOBs within 5 minutes.
Pair Keypad with Tracker	06	+	✓ OK	+	1. Enter Default PIN followed by Check-in/OK 2. Enter existing PIN followed by Check-in/OK 3. Enter 8 digit ESN (excluding the dash) followed by Check-in/OK
Sensor Alert Enable	07	+	✓ OK	+	1. Enter PIN 2. Press Check-in/OK 3. Press the number (1-4, 9 for all) of the contact to be enabled 4. Press Check-in/OK
1: #1 2: #2 3: #3 4: #4 9: All					
Sensor Alert Disable	08	+	✓ OK	+	1. Enter PIN 2. Press Check-in/OK 3. Press the number (1-4, 9 for all) of the contact to be disabled 4. Press Check-in/OK
1: #1 2: #2 3: #3 4: #4 9: All					
PIN Reset	09	+	✓ OK	+	1. Enter Last 4 digits of Authorization code 2. Press Check-in/OK 3. Enter new PIN followed by Check-in/OK 4. Enter new PIN again followed by Check-in/OK 5. Quick press Check-in/OK on each FOB
Vibration Sensitivity Setting	12	+	✓ OK	+	1. Press (1 = low, 2 = medium, 3 = high) Low setting is recommended for boats less than 30 ft. 2. Press Check-in/OK
Cancel SPOT Modes Activated on FOB	19	+	✓ OK	+	1. Enter PIN 2. Press Check-in/OK

BATTERY LIFE AND USAGE FOR TRACKER, KEYPAD AND KEY FOB

- Use only non-rechargeable AA Lithium batteries in your Tracker as a backup to line power. If using the Tracker with batteries only, follow guidelines in this section. We highly recommend Energizer™ Ultimate 8x AA Lithium batteries (L91). Alkaline or other battery technologies, including rechargeable varieties, are not recommended. In an emergency situation, if you only have access to Alkaline or other battery technologies, the Tracker might work, but will not meet the specified battery life or performance.
- Lithium batteries properly installed in the Tracker should last for several years stored. The On/Off LED will blink red when the Lithium batteries are low on battery power. If you are unsure as to the battery life remaining, replace the batteries immediately. Always test and verify your Tracker device before any trip.
- Under normal usage fully charged recommended batteries in a Tracker should meet or exceed the following:

Tracker: 4 AA Energizer Ultimate Lithium

SPOT MODE	THEFT RECOVERY MODE	BATTERY LIFE (DAYS)
None	No Vibration	336
None	Vibration, Armed, No Unauthorized Boat Movement	19
None	Vibration, Armed, Unauthorized Boat Movement	13
SOS or Help	Off	12
Track Progress	Off	19
Check-In/OK	Off	110

Keypad: 2 CR2032 cells

# OF BUTTON PRESSES PER DAY	BATTERY LIFE
0	6 years
5	2-1/2 years
10	1-1/2 years

Key FOB: 1 CR2032 cells

# OF BUTTON PRESSES PER DAY	BATTERY LIFE
0	1-1/2 years
5	1 year
10	240 Days

SPOT performance and battery life may be degraded in operating environments where the SPOT GPS chip must take a longer time to acquire your GPS location, such as trying to send a message indoors or under extreme canopies. Colder conditions can impact battery life. Under normal usage a full battery charge should meet or exceed these amounts.

1. SPOT recommends that you always carry an extra set of recommended batteries.
2. Colder conditions can impact battery life. Colder conditions and extreme heat can impact battery life.

The Tracker performance and battery life (if not line powered) may be degraded in operating environments where the Tracker GPS chip must take a longer time to acquire your GPS location, such as trying to send a message under non-RF transparent structures or under extreme canopies. If in an emergency situation where you only have alkaline or different non-rechargeable AA lithium batteries available, Tracker may be able to intermittently transmit messages but performance will be degraded.

The Tracker and Keypad are designed to be rugged for maritime use. The Key FOB unit is made to survive a short fall and submerged under water for a short period of time.

To ensure proper low battery indicator operation, SPOT recommends that new batteries are installed for all three devices (Tracker/FOB/Keypad) on a regular basis. Removing batteries and reinstalling them, or installing used batteries will shorten the total number of notifications that can be sent before the batteries go dead.

COVERAGE

HUG works around the world, including virtually all of North America, Europe, Australia and portions of South America, Northern Africa and Asia, as well as hundreds or thousands of miles off-shore of these areas. It is important that you check coverage for your destination before traveling. In Russia, GPS performance is limited (degraded) in accordance with Russian regulations regarding GPS accuracy for devices utilized in Russia. Go to findmeSPOT.com for the latest coverage map.

OPERATING CONDITIONS AND CLIMATE

For safety, keep the following in mind regarding the care and usage of each of the three HUG components:

TRACKER

- 12/24 VDC line power input.
- Waterproof to IPX7 standard (depth of 1 meter up to 30 minutes)
- Operating temperatures: -22°F to +185°F (-30°C to 85°C)
- Operating altitude: -328 ft to 21,320 ft (-100m to 6,500m)
- Humidity and Salt Fog rated.
- Vibration compliant Per SAE J1455, Random, 20 Hz to 2000 Hz, 0.04g2/Hz, one hour per axis
- Visit findmeSPOT.com for the latest information on certification to OSHA Intrinsically Safe to Class I, Division 1, Group A-D standards.

KEYPAD AND KEY FOB

- Operating temperatures: -8°F to +140°F (-20°C to 60°C).
Coin cells are rated from -20C to 60C.
- Humidity and Salt Fog rated
- Waterproof to IPX7 standard (depth of 1 meter up to 30 minutes).
- Able to withstand a drop on all six sides from 1 meter onto a concrete surface
- FOB and Keypad is vibration compliant Per SAE J1455, Random, 20 Hz to 2000 Hz, 0.04g2/Hz, one hour per axis

SMS INFORMATION

Additional charges may apply in some regions. Standard text messaging charges from your mobile phone provider may also apply.

TROUBLESHOOTING

The FOB/Keypad/Tracker components each perform a self-diagnostic test each time batteries are installed. SPOT recommends that you send and verify a Check-in/OK message before each trip. This also allows you to evaluate your entire messaging system, from the operational condition of the HUG to the readiness of those on your contact list.

WEB BROWSER REQUIREMENTS

For optimal performance, you must have a compatible web browser to access your SPOT user account at findmeSPOT.com. The following are compatible web browsers:

- FireFox 3
- Internet Explorer 7 & 8
- Safari 3 & 4

It is possible that other browsers such as Chrome 2.0 and Opera 9/10.0 will also work to access the findmeSPOT.com website and your user account, but compatibility is not assured. Check the FAQ section of the findmeSPOT.com website or contact HUG Customer Care for the most recent list of compatible browsers.

LEARN MORE

The SPOT website is updated regularly with training videos and answers to Frequently Asked Questions (FAQs).

FOR ADDITIONAL QUESTIONS OR SUPPORT

Visit findmeSPOT.com or call:

- North American Customers: 1-866-OK1-SPOT (1-866-651-7768).
- European Customers: Tel: +353 12 909 505

LIMITED WARRANTY

Spot LLC warrants that your SPOT HUG will be free from defects in materials and workmanship under normal use for a period of 12 months (24 months for European customers) from the date of original purchase from Spot LLC or an authorized reseller with receipt. For full details regarding the Limited Warranty and warranty claim procedures, visit findmeSPOT.com.

EXCEPT AS PROVIDED ABOVE, THE PRODUCT IS SOLD "AS IS" WITHOUT ANY EXPRESS OR IMPLIED WARRANTIES FOR THE PRODUCT WHATSOEVER, INCLUDING, WITHOUT LIMITATION, ANY IMPLIED WARRANTIES REGARDING THE CONDITION, DESIGN, SPECIFICATIONS, WORKMANSHIP, MERCHANTABILITY OR FITNESS FOR A PARTICULAR PURPOSE OF THE PRODUCT, OR ANY WARRANTIES THAT THE PRODUCT IS FREE FROM LATENT DEFECTS OR DEFICIENCIES, OR THAT THE PRODUCT IS FREE FROM INFRINGEMENT OF ANY PATENT, TRADEMARK, COPYRIGHT OR PROPRIETARY RIGHT OF ANY THIRD PARTY AND SUCH WARRANTIES ARE HEREBY EXPRESSLY DISCLAIMED.

THIS LIMITED WARRANTY PROVIDES THE SOLE AND EXCLUSIVE REMEDY FOR ANY DEFECTS IN THE PRODUCT. IN NO EVENT SHALL WE BE LIABLE FOR ANY INDIRECT, CONSEQUENTIAL, SPECIAL, INCIDENTAL OR PUNITIVE DAMAGES, WHETHER IN CONTRACT, TORT, NEGLIGENCE, STRICT LIABILITY OR OTHERWISE. OUR LIABILITY IS LIMITED TO THE AMOUNT YOU PAID FOR THE PRODUCT THAT IS THE SUBJECT OF A CLAIM. THE APPLICABILITY OF THE ABOVE LIMITATIONS AND EXCLUSIONS MAY VARY FROM STATE TO STATE, OR COUNTRY TO COUNTRY.

ANY MODIFICATION TO EITHER THE TRACKER, FOB, OR KEYPAD IS PROHIBITED AND WILL VOID YOUR WARRANTY. THE OPENING OF THE UNITS AND USE OF THE COMPONENTS FOR PURPOSES NOT OTHERWISE AUTHORIZED BY HUG IS PROHIBITED AND WILL VOID YOUR WARRANTY. IT IS NOT TO BE USED IN AIRPLANES OR ANY OTHER AVIATION APPLICATION.

FCC/IC NOTICE

This equipment has been tested and found to comply with the limits for a class B digital device, pursuant to Part 15 of the FCC rules. These limits are designed to provide reasonable protection against harmful interference in a residential installation. This equipment generates, uses, and can radiate radio frequency energy and, if not installed and used in accordance with the instructions, may cause harmful interference to radio communications. However, there is no guarantee that interference will not occur in a particular installation. If this equipment does cause harmful interference to radio or television reception, which can be determined by turning the equipment off and on, the user is encouraged to try to correct the interference by one or more of the following measures:

- Reorient or relocate the receiving antenna.
- Increase the separation between the equipment and the receiver.
- Connect the equipment into an outlet on a circuit different from that to which the receiver is connected.
- Consult the dealer or an experienced radio/TV technician for help.

This device automatically adjusts its transmission frequency according to its location and is compliant with international regulatory requirements.

This Class B digital apparatus complies with Canadian ICES-003.

FCC RF RADIATION EXPOSURE STATEMENT

This equipment complies with FCC RF radiation exposure limits set forth for an uncontrolled environment. This equipment should be installed and operated with a minimum distance of 20 cm between the radiator and your body.

WARNING STATEMENTS

WARNING! Danger of explosion if battery is incorrectly replaced. Replace only with the same or equivalent type recommended. Dispose of used batteries according to the manufacturer's instructions.

WARNING! Do not damage the rechargeable Lithium-ion battery. A damaged battery can cause an explosion or fire, and can result in personal injury and/or property damage.

