



# Product Specifications

## ZigBee Module - ZiP E2.1-PSLB



## Document History

Date	Author(S)	Revision	Comments
May-2014	Honky Yau	v0.1	First release
14-July-2014	Honky Yau	v0.2	Confirmed SPI IO's pin assignment Update Contact Information
23-July-2014	Honky Yau	v0.3	Update "3.1 RF specification" - Naming: Maximum input signal level -> Receiver input signal level - Max value : +5 dBm
30-Sep-2014	Honky Yau	v0.4	Update Mechanical Dimension - Module Height: from 3.0 to 2.9mm - Module Height tolerance: from TBD to 2.9 +/- 0.15mm
10-Feb-2015	Vincent Tse	v0.5	Updated Notice section
04-Mar-2015	Vincent Tse	v0.6	Updated Notice & Ordering Guide

# Contents

---

Contents .....	3
1. Key Features .....	5
1.1. System Description.....	5
1.2. Feature .....	5
1.3. Block Diagram.....	6
1.4. Module Pin Assignment.....	6
2. DC Electrical Specifications .....	10
2.1. Absolute Maximum Ratings .....	10
2.2. Power consumption.....	10
2.3. nRESET Pin Characteristics .....	10
3. Radio Performance.....	11
3.1. RF Specifications.....	11
4. Environmental Specifications.....	12
4.1. Environmental Specifications.....	12
5. Mechanical.....	13
5.1. Physical Dimensions .....	13
5.2. Recommended PCB pattern .....	15
5.3. Label Drawing .....	16
6. Ordering Guide.....	17
7. Notice.....	18



# 1. Key Features

---

## 1.1. System Description

ZiP E2.1 is a ZigBee module targeting for Home Automation and Smart Energy marketplaces. The module embedded with a high performance Cortex M3 ZigBee transceiver EM3586 from Silicon Labs (SiLabs) which is fully compliant with IEEE 802.15.4-2003 specifications. It provides a low cost, low power consumption and reliable wireless communication solution in the 2.4GHz ISM frequency band. Customer can implement applications easily with various interfaces provided by ZiP E2.1.

## 1.2. Feature

- Dimensions: 27.20mm x 14.75mm x 2.90mm
- SiLabs Ember EM3586 high-performance, integrated ZigBee/802.15.4 chipset
- Transmit power: up to +19 dBm
- Receiver sensitivity: -103dBm
- Supply voltage: 2.4V to 3.6V
- Security: 128-bit AES
- On-board chip antenna
- Serial Interface: USB/SPI/UART/I2C
- ADC: 14bits ADC port
- FCC & RoHS compliant
- MSL JEDEC level 3

### 1.3. Block Diagram

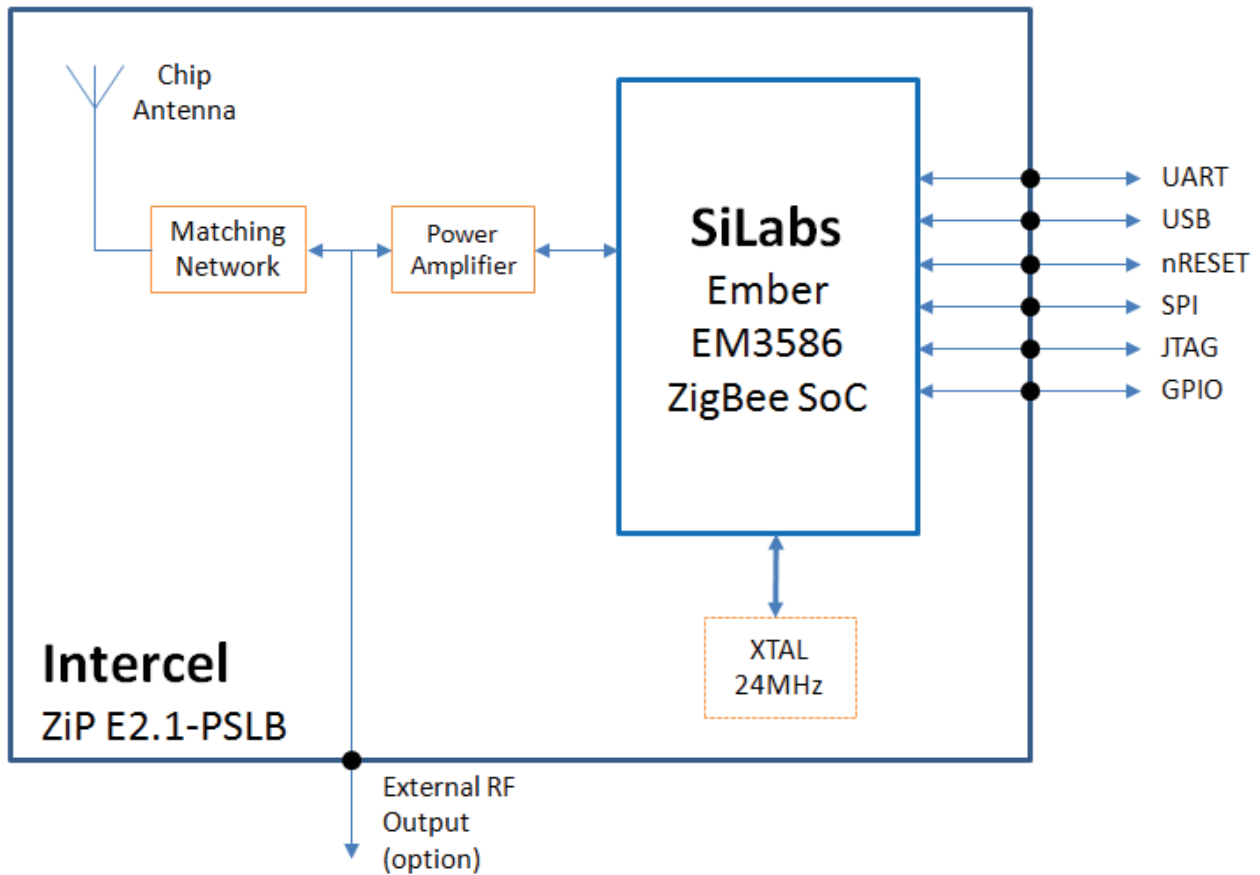

### 1.4. Module Pin Assignment

Pin#	Pin Name	I/O	Description
1	GND	-	Ground
2	Reserved	-	No connection
3	PC4/JTMS	I/O	Programmable I/O control, or JTAG mode select
4	PB0/IRQA	I/O	Programmable I/O control, or an interrupt input
5	PA3/SC2_nCS	O	Programmable I/O control, or External SPI serial flash, SPI nCS
6	PB6/ADC1/IRQB	I/O	Programmable I/O control, or ADC input, or an interrupt input

7	PC1/ADC3	I/O	Programmable I/O control, or an ADC input
8	SWCLK/JTCK	I	JTAG/Serial Wire debugging port clock
9	PC0/JRST/IRQD	I/O	Programmable I/O control, or an interrupt input, or the JTAG reset input
10	GND	-	Ground
11	PB5/ADC0	I/O	Programmable I/O control, or an ADC input
12	GND	-	Ground
13	GND	-	Ground
14	GND	-	Ground
15	GND	-	Ground
16	Reserved	-	No Connection
17	GND	-	Ground
18	RFO	O	RF output for external antenna (option)
19	nRESET	I	Module reset signal (Internal pull-up)
20	GND	-	Ground
21	GND	-	Ground
22	PA3	I/O	Programmable I/O control
23	GND	-	Ground

Pin#	Pin Name	I/O	Description
24	PC6/OSC32B	I/O	Programmable I/O control, or 32.768kHz crystal
25	PC7/OSC32A	I/O	Programmable I/O control, or 32.768kHz crystal
26	SC1SCLK/PB3	I/O	SPI port 1 clock, or programmable I/O control
27	PA0/USBDM/SC2MOSI	O	Programmable I/O control, or USB D- signal, or External SPI serial flash SPI master data out
28	PA1/USBDP/SC2MISO	I	Programmable I/O control, or USB D+ signal, or External SPI serial flash SPI master data in
29	VBATT	PWR	Module power supply
30	PA2/SC2SCLK	O	Programmable I/O control, or External SPI serial flash SPI master clock
31	PA4/ADC4	I/O	Programmable I/O control, or ADC input
32	GND	-	Ground
33	PA5/ADC5/nBOOTMODE	I/O	Programmable I/O control, or ADC input, or Boot control, must be left open or pulled high during the reset to enable the normal firmware boot process.
34	SC1MISO(s)/SC1MOSI(m)/ TXD/ SC1SDA/ PB1	I/O	SPI port 1 MISO (slave)/ MOSI (master) signal, or UART TXD signal, or I2C port 1 DATA signal, or Programmable I/O control
35	SC1MOSI(s)/SC1MISO(m)/ RXD/ SC1SCL/ PB2	I/O	SPI port 1 MOSI (slave)/ MISO (master) signal, or UART RXD signal, or I2C port 1 CLK signal, or Programmable I/O control
36	PC2/JTDO/SWO	I/O	Programmable I/O control, or Serial Wire port OUTPUT signal, or JTAG data out



Pin#	Pin Name	I/O	Description
37	SC1nSSEL/PB4	I/O	SPI port 1 slave select, or Programmable I/O control
38	PC3/JTDI	I/O	Programmable I/O control, or JTAG data in
39	GND	-	Ground
40	GND	-	Ground
41	GND	-	Ground
42	GND	-	Ground
43	GND	-	Ground
44	GND	-	Ground

## 2. DC Electrical Specifications

### 2.1. Absolute Maximum Ratings

Parameters	Test Conditions	Min	Max	Unit
Supply voltage		-0.3	+3.6 (VDDmax)	V
Voltage on any GPIO		-0.3	VDDmax	V

Under no circumstances the absolute maximum ratings must be violated. Stress exceeding one or more of the limiting values may cause permanent damage to the device.

### 2.2. Power consumption

VCC = 3.0V, Temperature = 25°C, F<sub>RF</sub> = 2440MHz (unless otherwise noted)

Parameters	Condition	Min	Typ	Max	Unit
Sleep mode	Internal RC oscillator on Processor, radio, peripherals off		1.2		uA
Standby mode	Processor on Radio and peripherals off		12		mA
Receive mode	Radio receive chain on		35		mA
Transmit mode +19dBm typical			175		mA
Serial controller current	For each controller at maximum data rate		0.2		mA
General purpose timer current	For each timer at maximum clock rate		0.25		mA
General purpose ADC current	At maximum sample rate, DMA enabled		1.1		mA

### 2.3. nRESET Pin Characteristics

Parameters	Min	Typ	Max	Unit
Reset pulse width to guarantee a reset		200	300	ns

## 3. Radio Performance

---

### 3.1. RF Specifications

VCC = 3.0V, Temperature = 25°C, Normal Mode measured at 50ohm terminal load

Parameters	Test Conditions	Min	Typ	Max	Unit
Frequency range		2405		2475	MHz
Transmitter power at maximum			+19		dBm
Receiver sensitivity			-103		dBm
Receiver input signal level				+5	dBm
Carrier frequency error		-40		+40	ppm

## 4. Environmental Specifications

---

### 4.1. Environmental Specifications

Parameters	Min	Max	Unit
Operating supply voltage	+2.4	+3.6	V
Operating Temperature	-40	+85	°C
Storage Temperature	-40	+85	°C
MSL Moisture Sensitivity Level		3	
RoHS Restriction of Hazardous Substances		Compliant	

## 5. Mechanical

### 5.1. Physical Dimensions



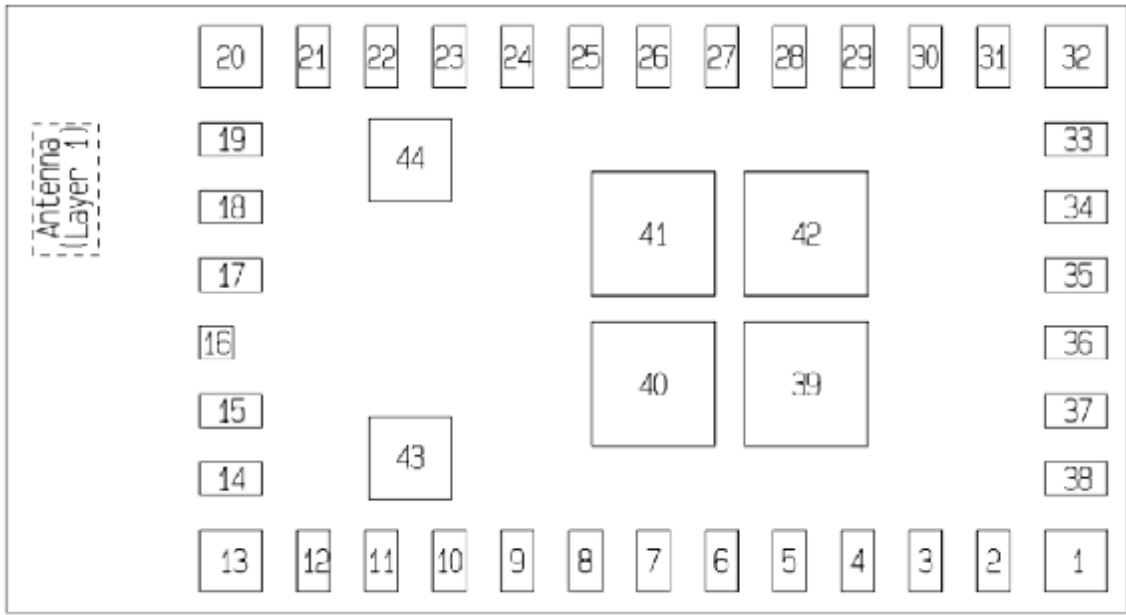

(Bottom view)

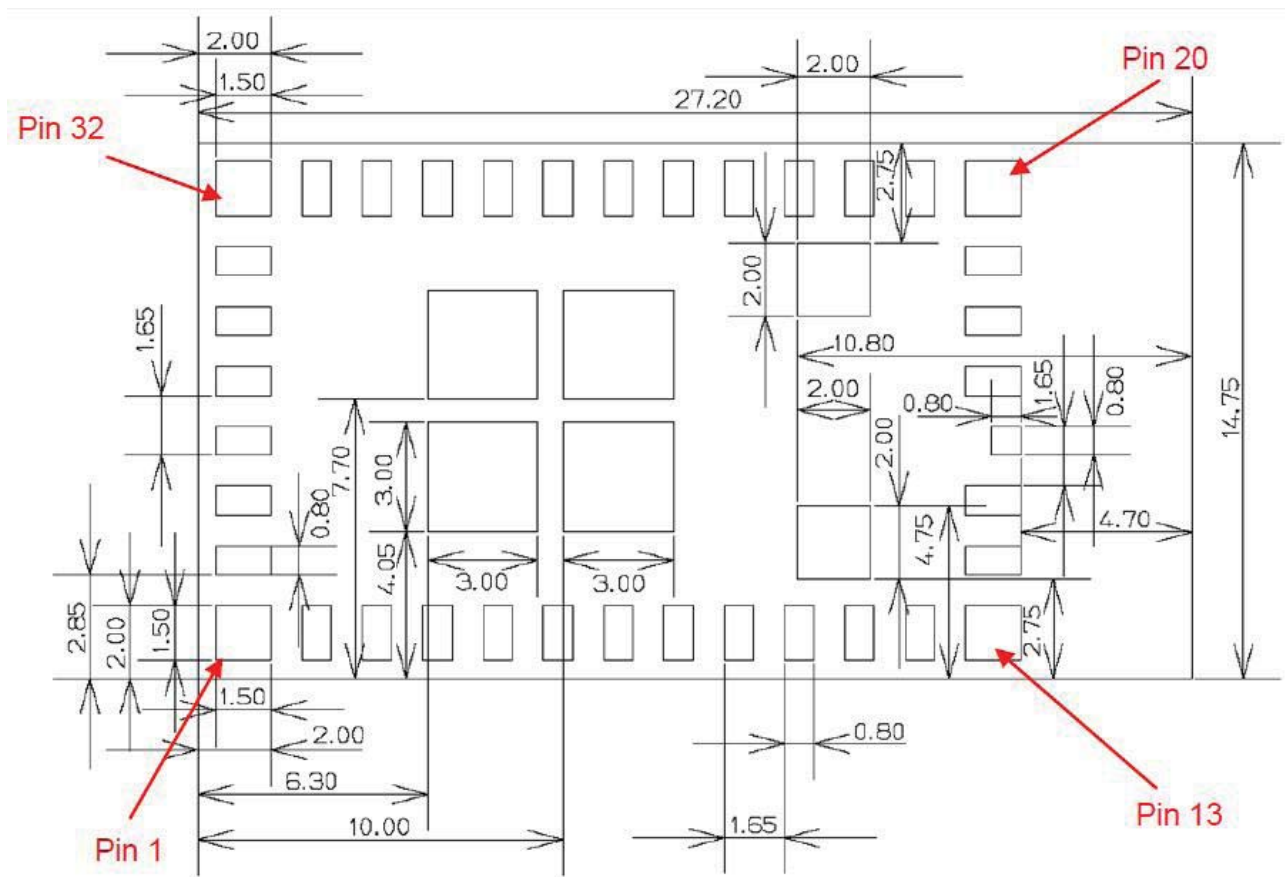

(Top view)

## 5.2. Recommended PCB pattern

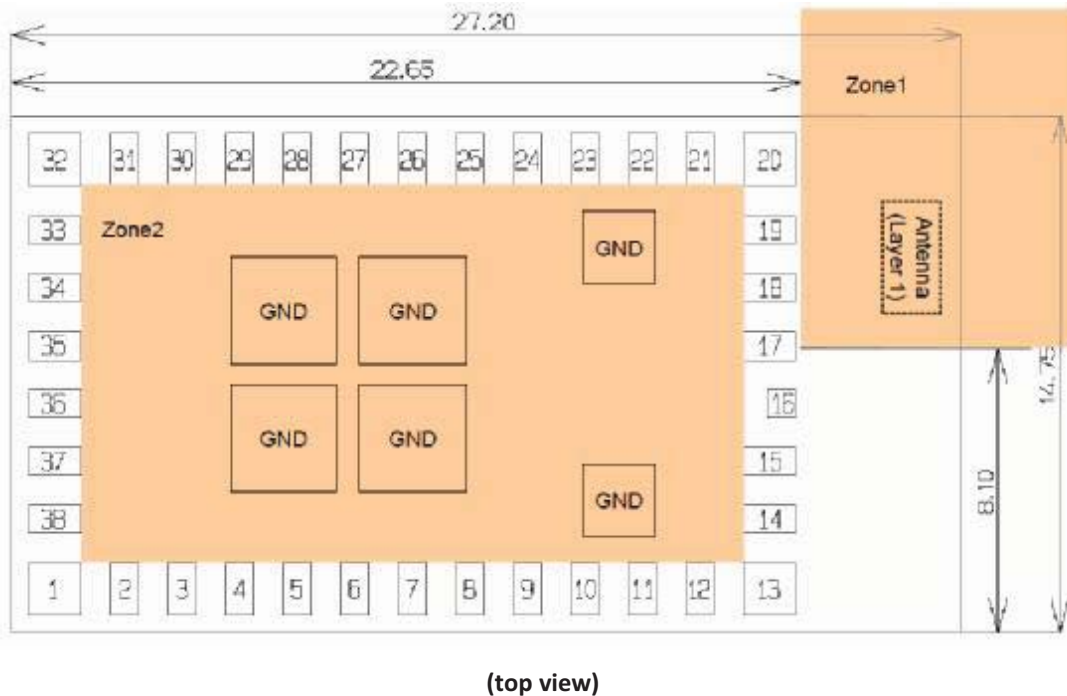
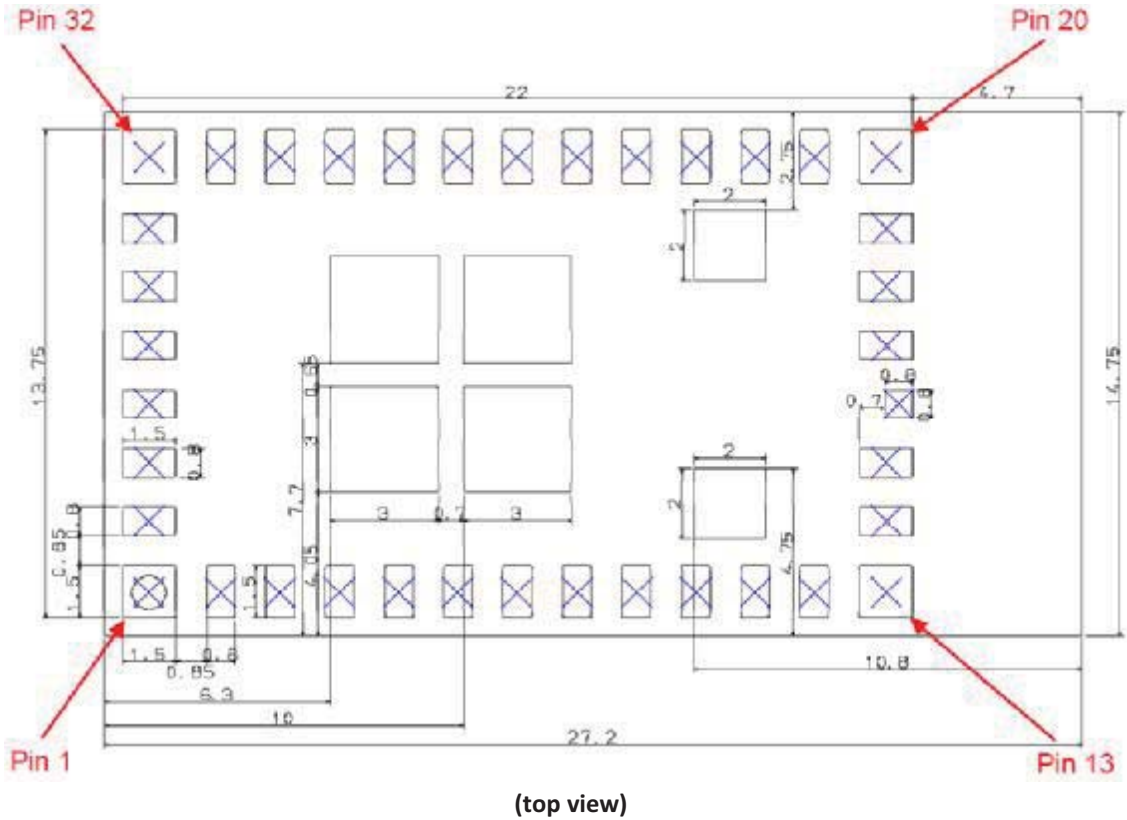

### Notes:

To achieve best RF performance, it is recommended to follow the layout requirement as listed

1. The area in "Zone1" (antenna area), all layers of customer circuit board should keep free from any metal objects
2. The area in "Zone2", top layer of customer circuit board should have ground with no signal traces

### 5.3. Label Drawing

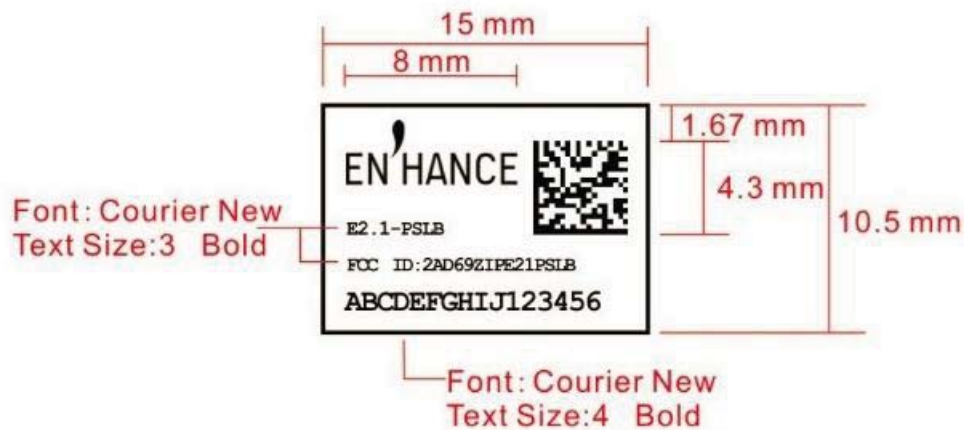

Product's Bar Code Requirement:  
Information: SN ONLY (13-16 char) + FCC ID

2D Bar Code Parameter (ONLY SN included)  
Type: Data Matrix  
Density: High  
Character Set: All 256 ASCII  
Error Correction: ECC 200

SN: 13~16 characters  
ABCDEFGHIJ123456

FCC ID: 2AD69ZIPE21PSLB



## 6. Ordering Guide

---

Ordering Part Number	Description	Package Type
P00-BI570PB-SFM0	ZiP E2.1-PSLB 2.4GHz ZigBee module (PA version)	Tape & Reel

## 7. Notice

---

This device complies with Part 15 of the FCC Rules. Operation is subject to the following two conditions:

1. This device may not cause harmful interference, and
2. This device must accept any interference received, including interference that may cause undesired operation.

**Note:** This equipment has been tested and found to comply with the limits for a Class B digital device, pursuant to part 15 of the FCC Rules. These limits are designed to provide reasonable protection against harmful interference in a residential installation. This equipment generates, uses and can radiate radio frequency energy and, if not installed and used in accordance with the instructions, may cause harmful interference to radio communications. However, there is no guarantee that interference will not occur in a particular installation. If this equipment does cause harmful interference to radio or television reception, which can be determined by turning the equipment off and on, the user is encouraged to try to correct the interference by one or more of the following measures:

- Reorient or relocate the receiving antenna.
- Increase the separation between the equipment and receiver.
- Connect the equipment into an outlet on a circuit different from that to which the receiver is connected.
- Consult the dealer or an experienced radio/TV technician for help.

**Caution:** Any changes or modifications not expressly approved by the party responsible for compliance could void the user's authority to operate this equipment.

### IC Statement

This device complies with Industry Canada licence-exempt RSS-210 standards. Operation is subject to the following two conditions: (1) this device may not cause interference, and (2) this device must accept any interference, including interference that may cause undesired operation of the device.

### France :

Le présent appareil est conforme aux CNR-210 d'Industrie Canada applicables aux appareils radio exempts de licence. L'exploitation est autorisée aux deux conditions suivantes : (1) l'appareil ne doit pas produire de brouillage, et (2) l'utilisateur de l'appareil doit accepter tout brouillage radioélectrique subi, même si le brouillage est susceptible d'en compromettre le fonctionnement.

*The modular can be installed or integrated in mobile or fix devices only. This modular cannot be installed in any portable device, for example, USB dongle like transmitters is forbidden. This modular complies with FCC RF radiation exposure limits set forth for an uncontrolled environment. This transmitter must not be co-located or operating in conjunction with any other antenna or transmitter. This modular must be installed and operated with a minimum distance of 20 cm between the radiator and user body.*

If the FCC identification number is not visible when the module is installed inside another device, then the outside of the device into which the module is installed must also display a label referring to the enclosed module. This exterior label can use wording such as the following: "Contains Transmitter Module FCC ID: 2AD69ZIPE21PSLB Or Contains FCC ID: 2AD69ZIPE21PSLB"

When the module is installed inside another device, the user manual of this device must contain below warning statements:

1. This device complies with Part 15 of the FCC Rules. Operation is subject to the following two conditions:
  - (1) This device may not cause harmful interference.
  - (2) This device must accept any interference received, including interference that may cause undesired operation.
2. Changes or modifications not expressly approved by the party responsible for compliance could void the user's authority to operate the equipment.

The devices must be installed and used in strict accordance with the manufacturer's instructions as described in the user documentation that comes with the product.

# Contact Information

## Intercel (China) Limited

Unit 6, 17/F, Vanta Industrial Centre,  
21-33 Tai Lin Pai Road,  
Kwai Chung, New Territories,  
Hong Kong SAR, China

t +852-2362 9018

f +852-2648 8806

## Shenzhen Office

Room 1303, 13/F, West Block,  
Tianan High-Tech Plaza Phase II,  
Tianan Cyber Park, Futian District,  
Shenzhen 518040, China

t +86-755-8835 3778

f +86-755-8835 2489

The information in this document is believed to be accurate in all respects at the time of publication but is subject to change without notice. Intercel™ assumes no responsibility for errors and omissions, and disclaims responsibility for any consequences resulting from the use of information included herein. Additionally, Intercel™ assumes no responsibility for the functioning of undescribed features or parameters. Intercel™ reserves the right to make changes without further notice. Intercel™ makes no warranty, representation or guarantee regarding the suitability of its products for any particular purpose, nor does Intercel™ assume any liability arising out of the application or use of any product or circuit, and specifically disclaims any and all liability, including without limitation consequential or incidental damages. Intercel™ products are not designed, intended, or authorized for use in applications intended to support or sustain life, or for any other application in which the failure of the Intercel™ product could create a situation where personal injury or death may occur. Should Buyer purchase or use Intercel™ products for any such unintended or unauthorized application, Buyer shall indemnify and hold Intercel™ harmless against all claims and damages.