

# OWNER'S MANUAL

Safety, Installation, Maintenance, and Operation

**Model V480 Compressor**  
**Model SUH-60 Compressor**  
**Model SHD-60 Compressor**



**Stellar Industries, Inc.**  
190 State Street  
PO Box 169  
Garner, IA 50438  
800-321-3741  
Fax: 641-923-2811  
[www.stellarindustries.com](http://www.stellarindustries.com)

# Class 4 Compressor Manual Revisions

---

Date of Revision	Section Revised	Description of Revision

# Table of Contents

---

<i>Introduction</i> . . . . .	<i>ii</i>
<b>Safety</b> . . . . .	<b>1</b>
<b>Specifications</b> . . . . .	<b>2</b>
General Specifications . . . . .	2
Compressor System Description . . . . .	2
SHD-60 Drive System Description . . . . .	2
<b>Operation</b> . . . . .	<b>3</b>
General Operation Notes . . . . .	3
SHD-60 Operation Notes . . . . .	3
<b>Maintenance</b> . . . . .	<b>4</b>
<b>Installation</b> . . . . .	<b>5</b>
Compressor Installation . . . . .	5
SHD-60 Installation . . . . .	6
Pressure Setting Instructions . . . . .	7
<b>Assembly Drawings</b> . . . . .	<b>8</b>
Crankcase Group (Tapered Shaft) . . . . .	8
Crankcase Group (Straight Shaft) . . . . .	9
Cylinder Group . . . . .	10
Head Group . . . . .	11
Head Options . . . . .	12
Optional Head Unloader . . . . .	14
Flywheel Options . . . . .	14
Clutch Options . . . . .	15
SUH-60 Compressor Assembly . . . . .	16
SHD-60 Compressor Assembly . . . . .	17
<b>Hydraulics/Electrical</b> . . . . .	<b>18</b>
SHD-60 Control Kit . . . . .	18
Typical Hydraulic Circuit for Tandem (Two Part) Pump with Multiple Components . . . . .	19
Typical Hydraulic Circuit for Single Stage Pump with Multiple Components . . . . .	19
Typical Hydraulic Circuit for Compressor with Auxiliary Cooler . . . . .	20
<b>Replacement Parts</b> . . . . .	<b>21</b>
<b>Troubleshooting</b> . . . . .	<b>22</b>
General Troubleshooting . . . . .	22
SHD-60 Troubleshooting . . . . .	23
<i>Warranty Information</i> . . . . .	<i>26</i>

# Introduction

---

American Eagle Compressors are designed to provide safe and dependable service for a variety of operations. With proper use and maintenance, American Eagle Compressors will operate at peak performance for many years.

This manual contains information vital to the safe use and efficient operation of this unit. Following the information provided within this manual can ensure the longevity of the compressor. Carefully read and study the operator's manual before using the unit. Failure to adhere to the instructions could result in property damage or even serious bodily injury to the operator or others close to the compressor.

A copy of this manual is provided with every compressor and shall remain with the compressor at all times. Information contained within this manual does not cover all maintenance, operating, or repair instructions pertinent to all possible situations. This manual is not binding.

American Eagle reserves the right to change, at any time, any or all of the items,

components, and parts deemed necessary for product improvement or commercial/production purposes. This right is kept with no requirement or obligation for immediate mandatory updating of this manual.

This product manual is not intended as a training manual for beginners or unskilled operators. This manual offers guidelines for correct and safe usage of the compressor, maintenance, and troubleshooting. If more information is required or technical assistance is needed, please contact AE Technical Support.

Some sections of this manual contain information pertaining to all American Eagle manufactured compressors and may or may not apply to your specific model.

If this manual becomes damaged, misplaced, or unreadable at any point, or if you feel that any part of this manual is unclear or incorrect, please contact AE Technical Support at 800-321-3741 or email at [service@americaneagleacc.com](mailto:service@americaneagleacc.com)

**For Technical Questions, Information, Parts, or Warranty, Call Toll-Free at  
800-321-3741**

Hours: Monday - Friday, 8:00 a.m. - 5:00 p.m. CST

Or email at the following addresses:

**Technical Questions, and Information**

[service@americaneagleacc.com](mailto:service@americaneagleacc.com)

**Order Parts**

[parts@americaneagleacc.com](mailto:parts@americaneagleacc.com)

**Warranty Information**

[warranty@americaneagleacc.com](mailto:warranty@americaneagleacc.com)

# Safety

This manual contains vital information for the safe use and efficient operation of this unit. Carefully read the operators manual before starting the unit. Failure to adhere to the instructions could result in serious bodily injury or property damage.

Every American Eagle Compressor will provide safe and dependable service if operated according to instructions. Read and understand the safety precautions given in this manual and on the decals attached to the shields. Failure to do so can result in personal injury or equipment damage.

Operators and maintenance personnel must always comply with the safety precautions. These precautions are given here for your safety. Review them carefully before operating the compressor and before performing maintenance or repairs.

Supervising personnel should develop additional precautions relating to the specific work area and local safety regulations.

## **Precautions**

Always wear safety equipment such as goggles, ear plugs and head protection at all times when operating the compressor.

Do not inspect or clean the compressor while the hydraulic power source is connected. Accidental engagement of the tool can cause serious injury.

Before performing any maintenance on the compressor, place a warning tag on the hydraulic power source or disconnect the hoses from the compressor motor to prevent accidental startup of the compressor.

Always connect hoses to the compressor

before energizing the hydraulic power source. Be sure all hose connections are tight, both air and hydraulic.

Establish a training program for all operators to ensure safe operation.

Do not operate the compressor unless thoroughly trained or under the supervision of an instructor.

Do not operate the compressor if it is damaged, improperly adjusted or not completely or properly assembled.

Never operate the compressor with any of the guards removed.

Do not attempt to adjust or disable the compressors air pressure relief valve. This valve limits the air pressure to 150 PSI.

The surface of the air compressor and the plumbing between the compressor and the cooler may reach temperatures above 150 degrees. Touching these surfaces during operation can cause burns.

The air taken in by the air compressor must be free of flammable fumes and vapors.

Compressor speed should not exceed 1300 RPM.

Use and operate this air compressor only in full compliance with all pertinent O.S.H.A. requirements and all Federal, State and Local codes or requirements.

# Specifications

## Compressor System Description

- Cast Iron Crankcase Casting
- Cast Aluminum Cylinder Head
- High Temperature Precision Pistons
- Stainless Steel Reed Valves
- Heavy Duty Journal Bushings
- Pulsation Manifold
- Heavy Ductile Iron Crankshaft
- Micro-honed Connecting Rods
- Tapered Roller Bearings
- Pressure Lubricated System
- Oil Pressure Gauge

## SHD-60 Drive System Description

- 10 GPM Hydraulic System
- 2500 PSI Pressure Relief Setting
- All Steel Plumbing W/ JIC Fittings
- 361 CFM, 12 Volt Cooler Fan
- Direct Drive Coupling
- 1800 PSI System Pressure
- 12 VDC Solenoid Control Valve
- 165 Sq. In., 300 BTU Cooler
- 6061 Aluminum Manifold
- Air Pressure Control Valve

## General Specifications

- Model: V480
- Weight: 87 lbs (SHD-60: 175 lbs)
- Displacement @ 1200 RPM: 44 CFM
- Delivery: 28 CFM @ 100 PSI
- Maximum Working Pressure: 155 PSI
- Oil Capacity: 1 Quart
- Cylinders: Four Cylinder(Single Stage)
- Pressure switch presets: Engage - 115 PSI  
Disengage - 150 PSI

# Operation

## General Operation Notes

Each compressor is bench tested under load at the factory to ensure proper break-in and operation. While it is not necessary to follow any break-in procedure, the following checks should be made before putting the unit into service and periodically during use.

### Before Start-Up

Check the oil level in the compressor with the dipstick on the unit. If oil is needed, use American Eagle synthetic compressor oil (P/N C0087) or an equivalent synthetic oil. **Note: There may be oil left in the crankcase from the factory bench test. Overfilling may cause the compressor to back blow oil. Always check the oil level and fill to the designated marking on the dipstick before putting the unit into service.**

Check the air intake filters on each head to make certain that they are clean and unobstructed. Dirty air filters are a possible cause of reduced air output.

To use the compressor, start the engine and engage the hydraulic system with the compressor toggle switch. Through the hydraulic valve manifold, the system will now function automatically. Once engaged, adjust the engine speed control to ensure that the compressor speed does not exceed 1300 RPM under load.

## SHD-60 Operation Notes

If adjustment is necessary for cable operated speed controls, loosen the jam nut on the cable end, make the adjustment and retighten the jam nut.

For electronic operated speed controls, adjust speed adjustment screw as needed to set RPM.

For setting engine RPM through the chassis ECM, contact local chassis dealer.

When the air pressure falls below 120 PSI, the 12 volt electric solenoid opens allowing hydraulic oil to flow to the hydraulic drive motor then back to the manifold and through the oil cooler assembly. Once the air pressure reaches 150 PSI the solenoid closes shutting off the oil flow to the motor and diverts the oil to the oil cooler.

With the compressor engaged, the main cooling system, which consists of an oil cooler, electric fan motor and fan continually runs drawing ambient air through the cooler fins and across the fan assembly discharging heated air past the compressor and out the cover assembly.

# Maintenance

The following table is a list of routine maintenance items, including service intervals. Service intervals are listed as hours, days, or weeks, whichever occurs first. American Eagle recommends that these service intervals be followed.

Service Intervals				
Maintenance operation	Daily	Weekly	Monthly	Hourly
Drain air tanks	<input checked="" type="checkbox"/>	<input checked="" type="checkbox"/>	<input checked="" type="checkbox"/>	<input checked="" type="checkbox"/>
Check crankcase oil level	<input checked="" type="checkbox"/>			
Check fittings and airlines	<input checked="" type="checkbox"/>			
Check hydraulic fluid level	<input checked="" type="checkbox"/>			
Inspect and clean air intake filters		<input checked="" type="checkbox"/>		
Clean and operate safety valves		<input checked="" type="checkbox"/>		
Clean cooling fins on radiator		<input checked="" type="checkbox"/>		
Inspect check valve		<input checked="" type="checkbox"/>		
Inspect and clean compressor valves			6	
Replace hydraulic filter			6	
Replace air filters			3	
Tighten all fittings and fasteners			3	
Check all electrical connections			3	
Check compressor reed valves				250
Inspect and clean air check valve				250
<b>CHANGE CRANKCASE OIL (see footnote below)</b>				

Under normal operating conditions, oil changes are required every 3 months. When operating in a dirty environment, change the oil more frequently as your particular operating condition dictates.

**USE AE SYNTHETIC COMPRESSOR OIL P/N C0087.  
COMPRESSOR CRANKCASE CAPACITY IS 1 QUART.**

General preventative maintenance includes maintaining proper fluid level in both systems and the general cleanliness of the equipment. Proper fluids according to the specifications are required.



# Installation

## Compressor Installation

### Component Installation

This section pertains to the installation of the air compressor, PTO, pump and other related items. The instructions are intended as a guide to assist you with particular installation. These instructions will provide only general information.

### Torque and Procedure Chart

#### Pulsation Chamber Assembly

Torque Value: 31 FT. LBS.

**Procedure: See Head Assembly.**

#### Head Assembly

Torque Value: 31 FT. LBS.

Procedure: Assemble both heads on the cylinders with head bolts started only, not tight. Set pulsation chamber in place between heads, making sure the "O" ring is in place in each head. Screw the (4) chamber mounting bolts down but not tight. Snug (6) head bolts in each head to light torque. Tighten (4) chamber bolts to 31 Ft-lbs. torque. Tighten (6) head bolts in each head to 31 Ft-lbs. torque, doing the (2) long center bolts first and the (4) short bolts last. After five hours of use re-torque bolts to 31 Ft-lbs.

#### Cylinder Assembly

Torque Value: 20 FT. LBS.

Procedure: After assembling cylinder over pistons and setting into place, tighten (6) cap screws finger tight. In a criss-cross pattern, tighten bolts evenly so all bolts are hand snug. Again in a criss-cross pattern torque each bolt to 20 Ft-lbs., checking each bolt twice. After five hours of use, re-torque bolts to 20 Ft-lbs.

#### Connecting Rod Assembly

Torque Value: 18 FT. LBS.

Procedure: Assemble rod onto the crankshaft taking care to align the machined surfaces together and tighten cap screws finger tight. Tighten bolts until hand tight and torque to 18 Ft-lbs. Check twice the torque reading before final assembly of the cylinders.

## SHD-60 Installation

### Pump Assembly:

The pump assembly may either be installed directly on the PTO or as an optional method, may be driven by a driveline from the PTO. Pump manufacturers provide specific installation information for their products and should be consulted if questions arise.

### PTO Assembly:

Check with the PTO manufacturer's representative for specific instructions regarding your particular make, model, and year of vehicle. As some trucks may require modification of the transmission cross member and the exhaust system, the manufacturer's instructions should be followed to insure proper installation of the PTO.

### Compressor Assembly:

Prepare the mounting location of the compressor by locating and drilling four (4) holes, 7/16" diameter as per the mounting pattern of the air compressor base. Using four (4) 3/8" x 1.25 GR-5 cap screws, 3/8" flat washers, and 3/8" nyloc nuts, secure the compressor in place. The compressor is air cooled, and must have a clean supply of cooling air to the fan with minimum restrictions. Adequate space must be provided for proper circulation of air.

### Electrical Connections:

From the air pressure switch there are two (2) wires, red and black, running to the outside of the compressor housing. Connect the black wire to the vehicle frame or other suitable ground. Mount a single throw toggle switch in a convenient location and connect the red wire from the compressor to this switch. Connect the other switch terminal to a fuse holder and then to a 12-volt power supply. A third wire is required from the air compressor switch when connecting the speed control into the system. (See drawing below)

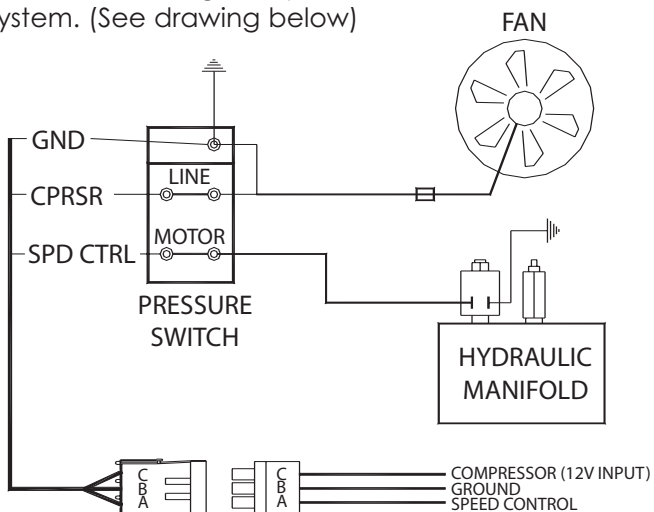

### Electric speed control:

An optional electric or electronic speed control must be used to maintain proper operating speed of the air compressor. The engine speed control will automatically increase from idle to preset speed when engaged and decrease when disengaged. The electric cable pull speed control Stellar P/N 25740 is used on most gasoline engines. The electronic speed controls are used only on Ford 7.3 and 6.0L diesel engines. Proper installation instructions are provided with each system.

### Hydraulic System:

The hydraulic system consists of the pump, oil reservoir, filters and hoses. Installed on the compressor is a valve block assembly that controls the flow to the hydraulic motor. To this block, a 1/2" high-pressure hose must be attached. This hose comes from the hydraulic pumps pressure side. A 3/4" minimum low-pressure return line is connected to the oil cooler outlet and is routed to the oil reservoir. American Eagle recommends a sufficient sized reservoir be provided which includes the proper suction and return filters. The cooler on the compressor is designed and sized to cool the air compressor efficiently. An auxiliary oil cooler is required when additional hydraulically operated equipment are added to the hydraulic system. Pressure on the return line exceeding 200 PSI can and will cause damage to the filter, cooler, and components of the compressor hydraulic system.

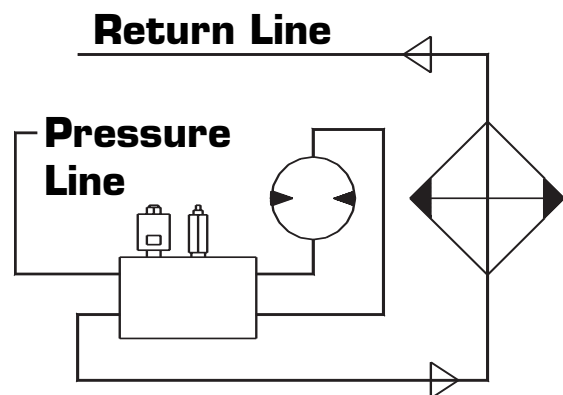

## Pressure Setting Instructions

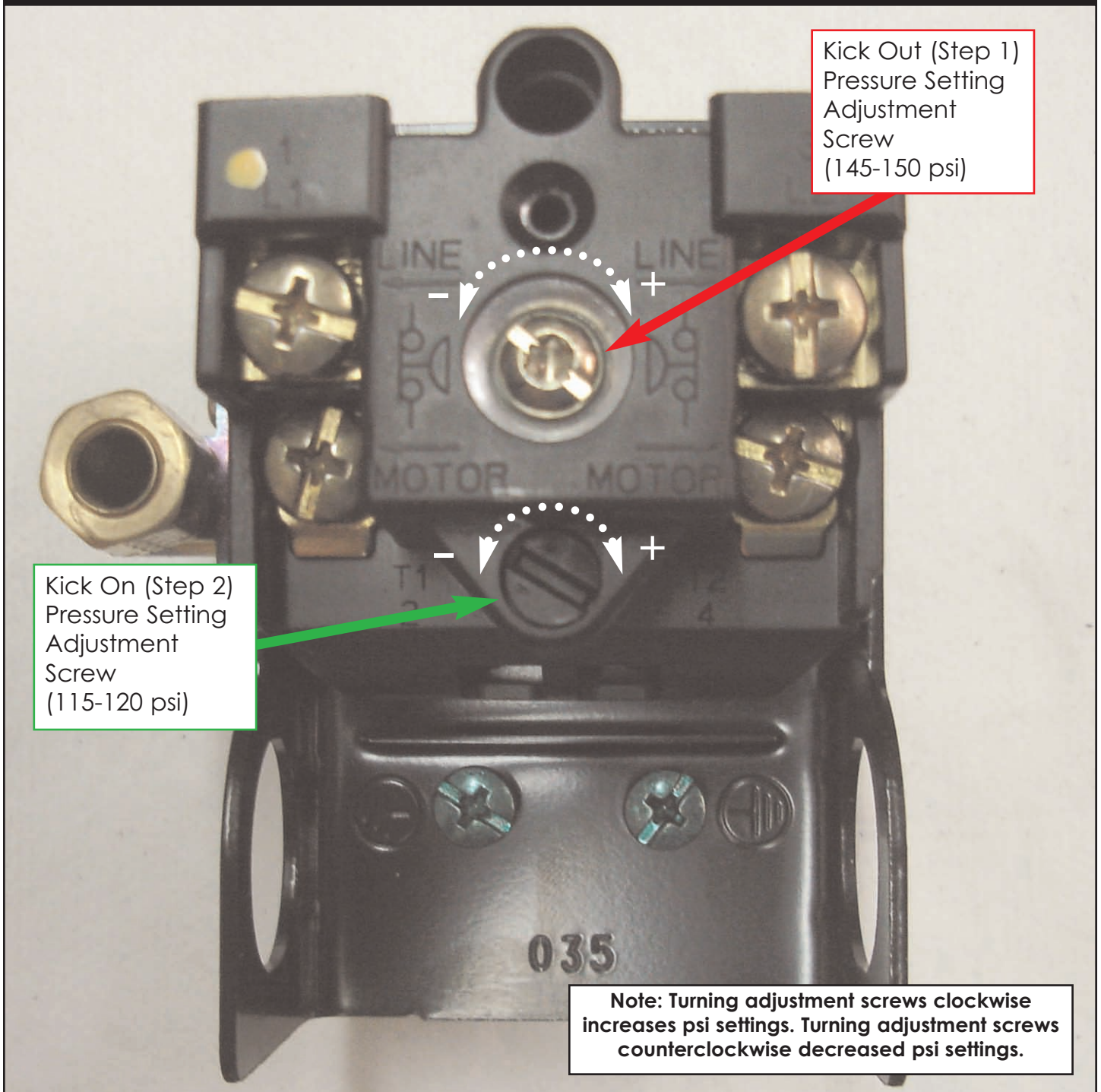

### **Pressure Setting Instructions:**

1. **Always set the kick out pressure setting first.** 145 psi minimum/150 psi maximum.
2. After kick out pressure is set, adjust the kick on screw setting at 115 psi minimum/120 psi maximum.
3. Cycle compressor to verify correct settings.
4. For questions about this procedure, please contact Stellar Customer Service.

# Assembly Drawings

## CRANKCASE GROUP (Tapered Shaft)

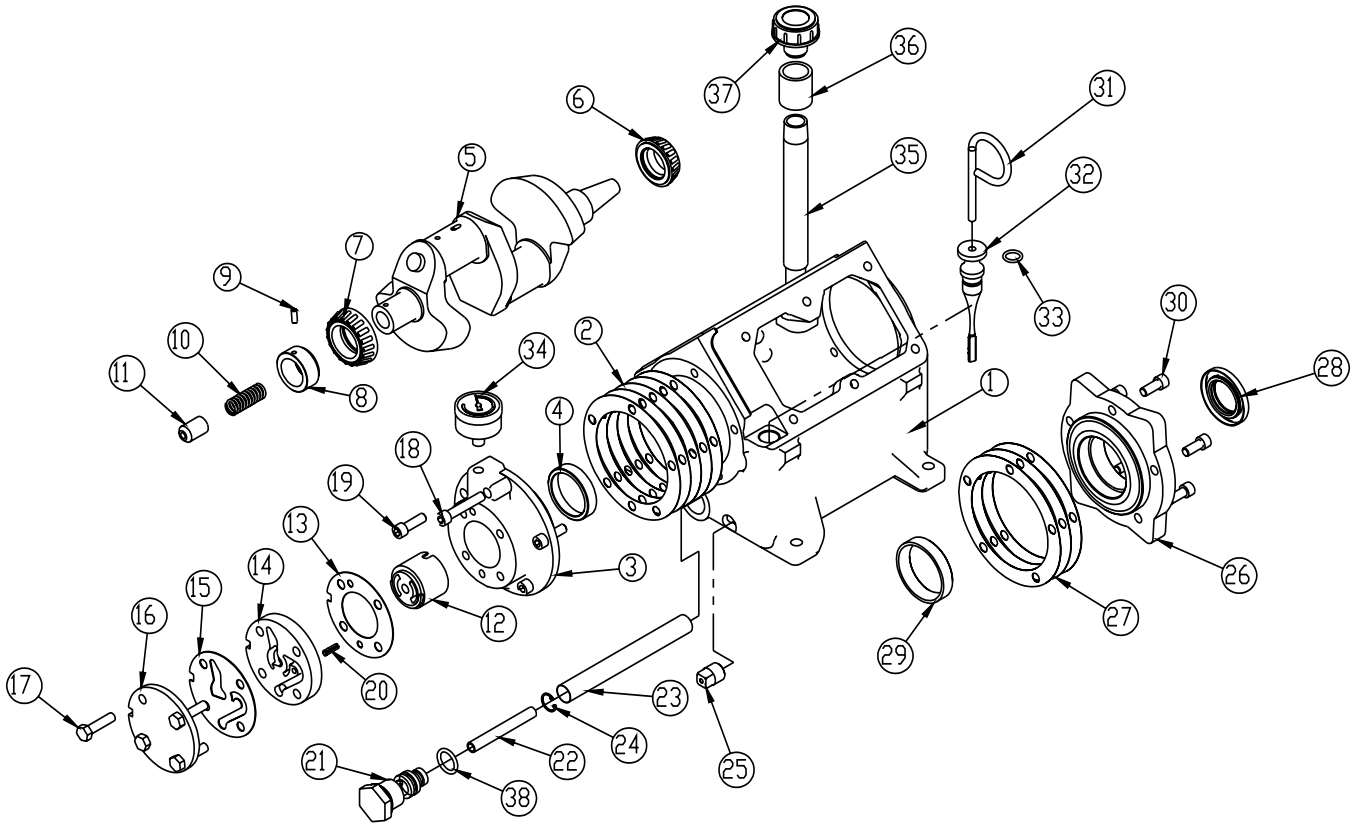

### CRANKCASE GROUP

ITEM	PART	DESCRIPTION	QTY.	ITEM	PART	DESCRIPTION	QTY.
1	C1174	CRANK CASE V480/360	1	20	22209	ROLL PIN 0.19X.63	1
2	5822	GASKET BEARING CARRIER-V480 (.015)	5	21	C0055	OIL INTAKE PLUG	1
3	5821	BEARING CARRIER OIL PUMP V360/V480	1	22	C5416	TUBE OIL PICK UP	1
4	C1164	BEARING CUP (L44610)	1	23	C0058	OIL INTAKE FILTER SCREEN	1
5	5824	CRANKSHAFT V480 TAPER	1	24	C6273	SNAP RING PISTON PIN N5000-62	1
6	C0856	BEARING CONE LM67048	1	25	C4841	PLUG 0.38 NPT SQ HD BLK	1
7	C0855	BEARING CONE	1	26	23482	BEARING CARRIER V480 O/S	1
8	5820	OIL PUMP DRIVE SLEEVE V480/V360/200	1	27	C6271	FRONT PL GASKET	3
9	5817	ROLL PIN 0.19X.50	1	28	5825	BEARING SEAL V480	1
10	C0060	SPRING OIL PUMP	1	29	C1163	BEARING CUP (LM67010)	1
11	C0059	OIL PUMP TRANSFER BUSHING	1	30	5813	CAP SCR 0.31-18X0.75 SH	5
12	C0050	OIL PUMP	1	31	22686	HANDLE DIPSTICK OIL CHECK V480	1
13	C6275	PORT PLATE GASKET	1	32	22210	DIPSTICK OIL CHECK V480	1
14	C0052	PORT PLATE MACHINED	1	33	C0041	O'RING-112	1
15	C0054	PORT PLATE COVER GASKET (SMALL)	1	34	5819	GAUGE OIL PSI 1.5	1
16	22626	PORT PLATE COVER	1	35	C0062	BREATHER BODY	1
17	0485	CAP SCR 0.31-18X1.25 HHGR5	4	36	C5929	COUPLER 0.50 BLK	1
18	6031	SCREW 0.31-18X1.00 SHC	1	37	22868	BREATHER CPRSR .50NPT NY8	1
19	6034	SCREW 0.31-18X1.00 SHC	4	38	C0057	O'RING 2-115 FOR OIL PICKUP TUBE	1

# Crankcase Group (Straight Shaft)

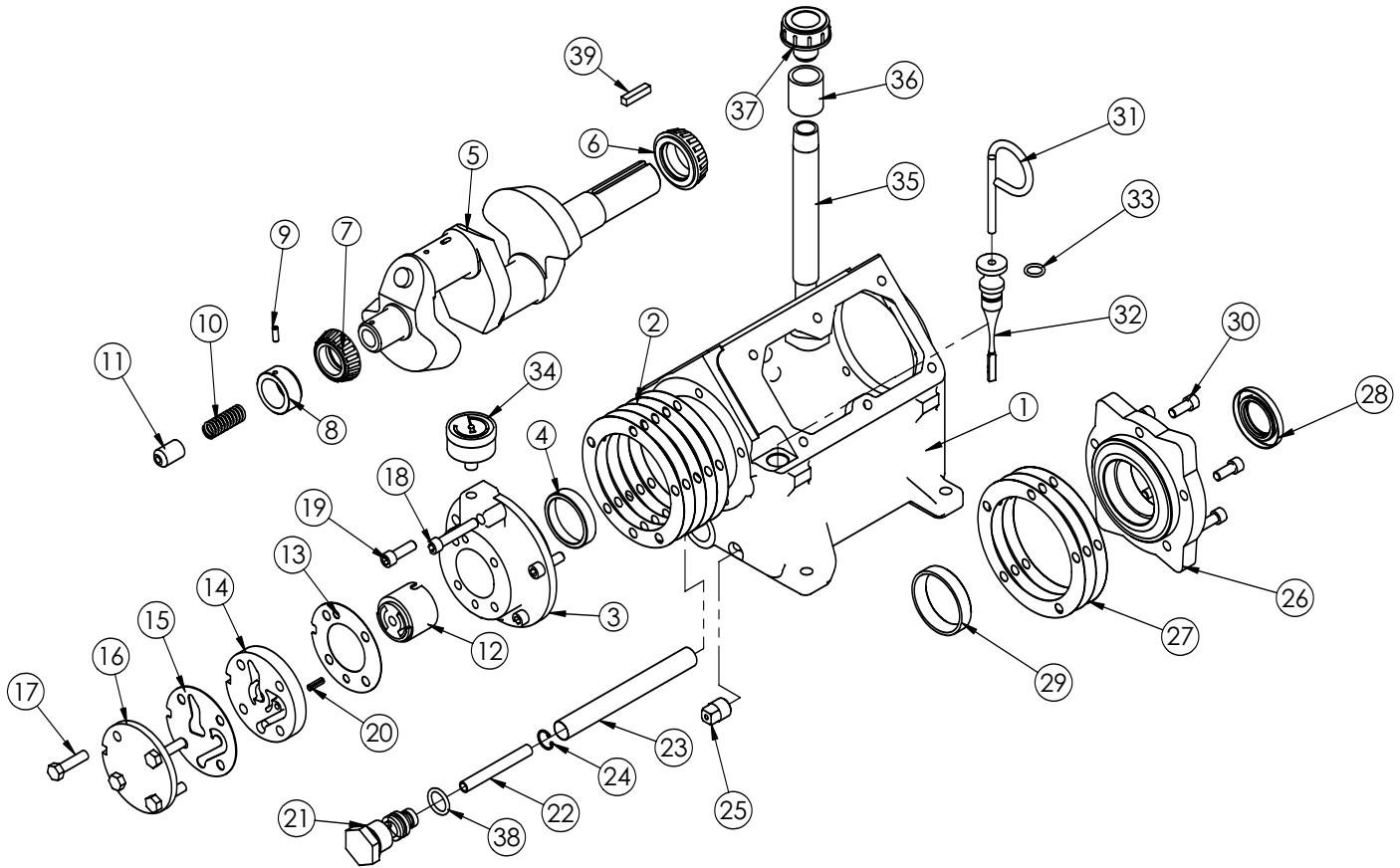

## CRANKCASE GROUP

ITEM	PART	DESCRIPTION	QTY.	ITEM	PART	DESCRIPTION	QTY.
1	C1174	CRANK CASE V480/360	1	14	C0052	PORT PLATE MACHINED	1
2	5822	GASKET BEARING CARRIER-V480 (.015)	5	15	C0054	PORT PLATE COVER GASKET (SMALL)	1
3	5821	BEARING CARRIER OIL PUMP V360/V480	1	16	22626	PORT PLATE COVER	1
4	C1164	BEARING CUP (L44610)	1	17	0485	CAP SCR 0.31-18X1.25 HHGR5	4
5	22834	CRANKSHAFT V480 S	1	18	6031	SCREW 0.31-18X1.00 SHC	1
6	C0856	BEARING CONE LM67048	1	19	6034	SCREW 0.31-18X1.00 SHC	4
7	C0855	BEARING CONE	1	20	22209	ROLL PIN 0.19X.63	1
8	5820	OIL PUMP DRIVE SLEEVE V480/V360/200	1	21	C0055	OIL INTAKE PLUG	1
9	5817	ROLL PIN 0.19X.50	1	22	C5416	TUBE OIL INTAKE .38 X 3.00	1
10	C0060	SPRING OIL PUMP	1	23	C0058	OIL INTAKE FILTER SCREEN	1
11	C0059	OIL PUMP TRANSFER BUSHING	1	24	C6273	SNAP RING PISTON PIN N5000-62	1
12	C0050	OIL PUMP	1	25	C4841	PLUG 0.38 NPT SQ HD BLK	1
13	C6275	PORT PLATE GASKET	1	26	23482	BEARING CARRIER V480 FT 480/360/OS	1

ITEM	PART	DESCRIPTION	QTY.
27	C6271	FRONT PL GASKET	3
28	5825	BEARING SEAL V480	1
29	C1163	BEARING CUP (LM67010)	1
30	5813	CAP SCR 0.31-18X0.75 SH	5
31	22686	HANDLE DIPSTICK OIL CHECK V480	1
32	22210	DIPSTICK OIL CHECK V480	1
33	C0041	O'RING-112	1
34	5819	GAUGE OIL PSI 1.5	1
35	C0062	BREATHER BODY	1
36	C5929	COUPLER 0.50 BLK	1
37	22868	BREATHER CPRSR .50NPT NY8	1
38	C0057	O'RING 2-115 FOR OIL PICKUP TUBE	1
39	23047	KEY FLYWHEEL 1/4	1



# Cylinder Group

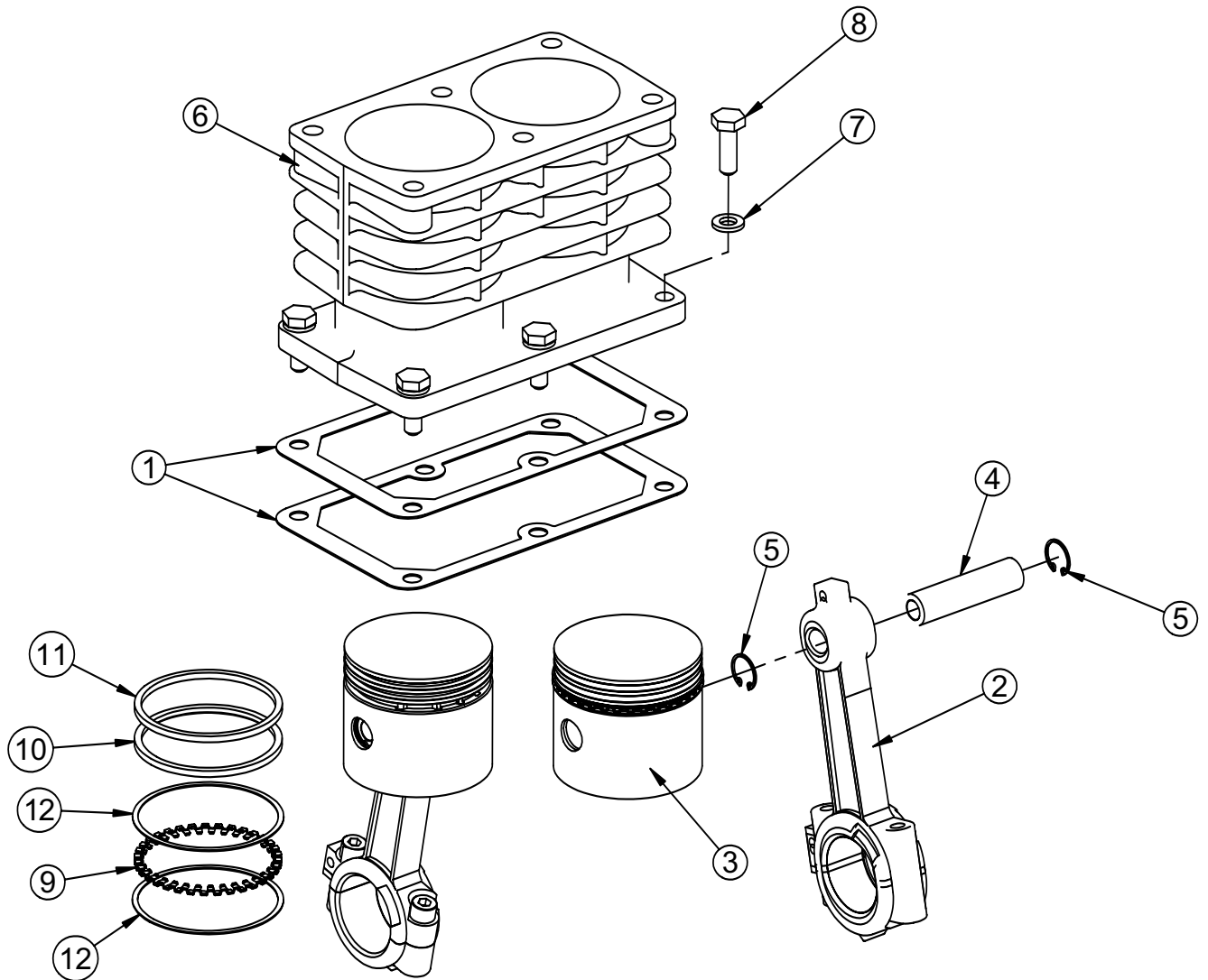

## CYLINDER GROUP

ITEM	PART	DESCRIPTION	QTY.
1	C0047	CYLINDER GASKET	2
2	C6364	CONNECTING ROD 200/V480 O/S	2
3	5767	PISTON 200/V480	2
4	C6367	PISTON PIN 200/V480	2
5	C6273	SNAP RING PISTON PIN N5000-62	4
6	C6360	CYLINDER V480 FINISHED O/S	1
7	0522	WASHER 0.31 LOCK	6
8	C0922	CAP SCR 0.31-18X1.00 HHGR5	6
9	5827	RING OIL V480/200 FLEX DIVIDER	2
10	32931	RING SCRAPER V480/200 H#48638	2
11	32930	RING CPRSN V480/200 BARREL H#38347	2
12	36368	RING OIL V480/200 RING RAIL	4

# Head Group

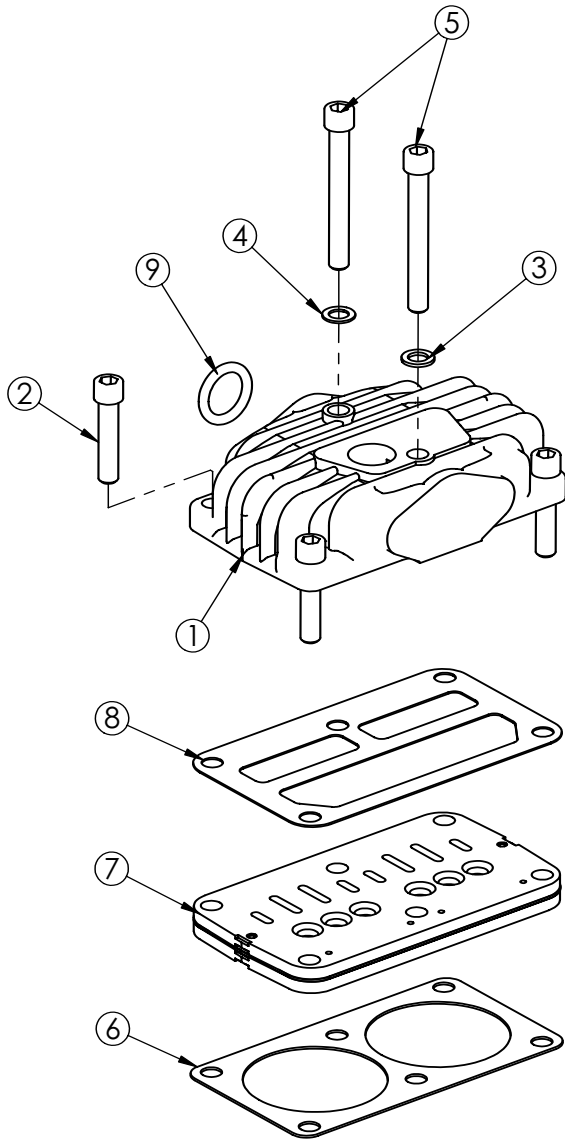

## HEAD GROUP

ITEM	PART	DESCRIPTION	QTY.
1	15195	HEAD A/C THD INTAKE V480 O/S	1
2	C1586	CAP SCR 0.38-16X1.75 SH HEAD BOLT	4
3	C0040	WASHER HD BOLT STL	1
4	5828	WASHER LONG HD BOLT (BRASS)	1
5	C1582	CAP SCR 0.38-16X3.00 SH HEAD BOLT	2
6	D0887	GASKET VALVE PLATE 200/480	
7	24103	VALVE PLATE SUB ASM O/S	1
8	C0310	GASKET HEAD 143/230/360/480	1
9	C0291	O'RING-214 VITON 9009-75	1

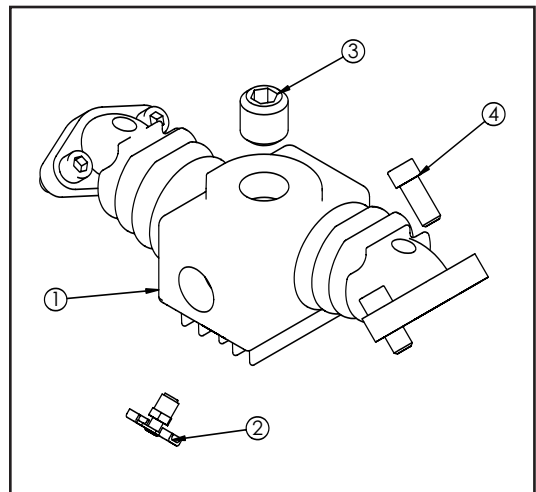

## MANIFOLD DISCHARGE

ITEM	PART	DESCRIPTION	QTY.
1	D0846	MANIFOLD V480 DISCHARGE O/S	1
2	5797	DRAIN COCK-V480	1
3	6000	PLUG 0.75 NPT SQ HD CS BLK	1
4	C1166	0.44 X 1.00 PULSATION TANK BOLT	4

# Head Options

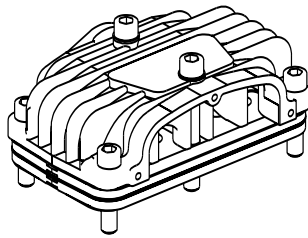

**#5808**  
**Aluminum Air Cooled**  
**Imbedded Filter & 3/4"**  
**Threaded NPT Discharge**

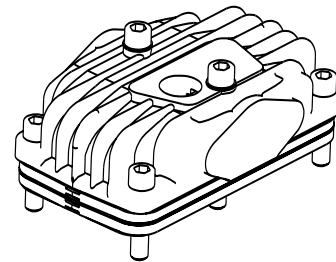

**#15195**  
**Cast Iron Air Cooled**  
**3/4" Threaded Intake Port**  
**on Top of Head with**  
**3/4" Discharge Port**

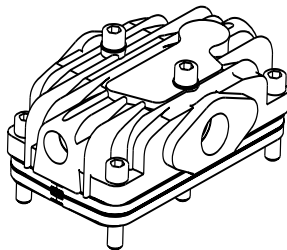

**#C1632**  
**Aluminum Water Cooled**  
**3/4" Threaded Inlet & 3/4"**  
**Threaded NPT Discharge**

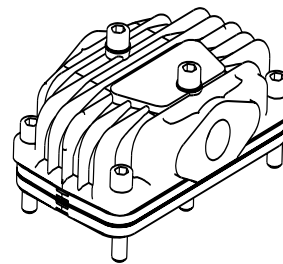

**#3897**  
**Cast Iron Air Cooled**  
**3/4" Threaded Inlet & 3/4"**  
**Threaded NPT Discharge**

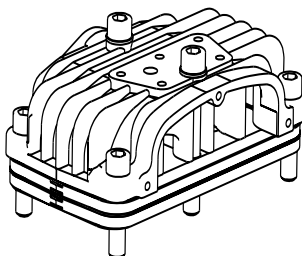

**#22996**  
**Cast Iron Air Cooled**  
**Imbedded Filter & 3/4"**  
**Threaded NPT Discharge**  
**with Head Unloader Ports**

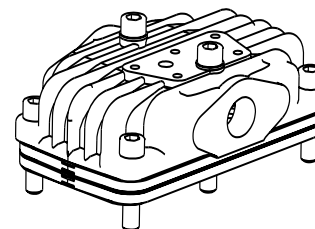

**#23039**  
**Cast Iron Air Cooled**  
**3/4" Threaded Inlet & 3/4"**  
**Threaded NPT Discharge**  
**with Head Unloader Ports**

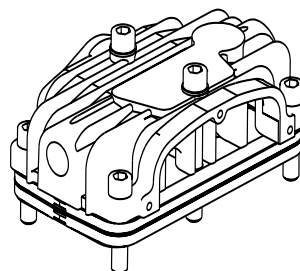

**#C1631**  
**Aluminum Water Cooled**  
**Imbedded Filter & 3/4"**  
**Threaded NPT Discharge**



# Optional Head Unloader

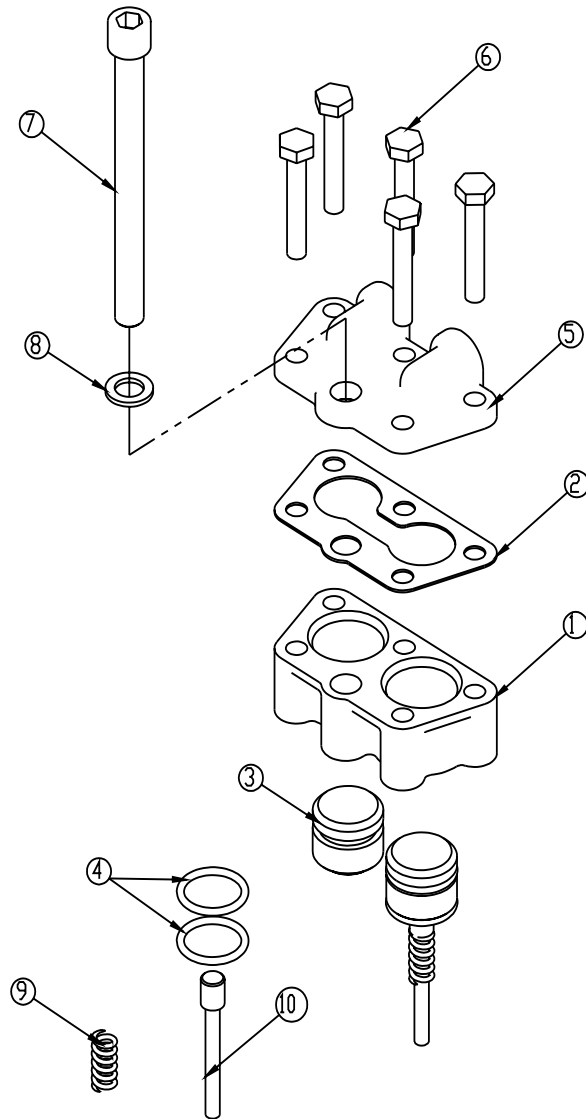

## PN 23200

ITEM	PART	DESCRIPTION	QTY.	ITEM	PART	DESCRIPTION	QTY.
1	22591	BODY HEAD UNLOADER CPRSR	1	6	0220	CAP SCR 0.25-20 X 1.50 HHGR5	5
2	22599	GASKET UNLOADER	1	7	22596	CAP SCR 0.38-16X4.00 SH HEAD BOLT	1
3	22593	PISTON HEAD UNLOADER CPRSR	2	8	C0040	WASHER HD BOLT STL	1
4	22598	O-RING 2-116 HEAD UNLOADER CPRSR	4	9	22597	SPRING PLUNGER PIN UNLOADER CPRSR	2
5	22592	COVER HEAD UNLOADER CPRSR	1	10	22594	PIN PLUNGER HEAD UNLOADER CPRSR	2

## Flywheel Options

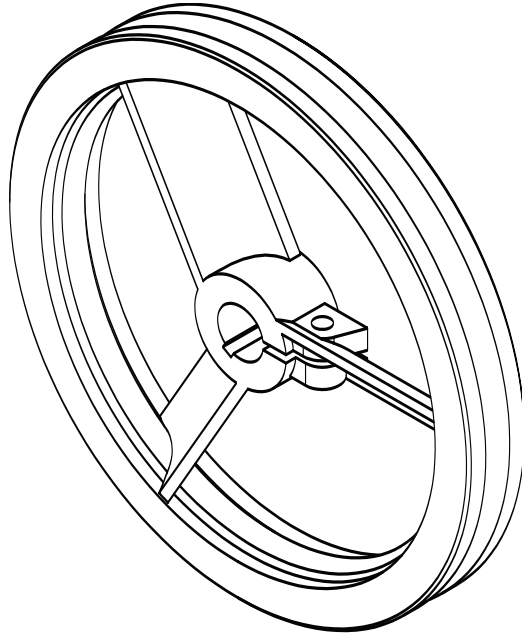

**22997**  
**12" - B GROOVE**

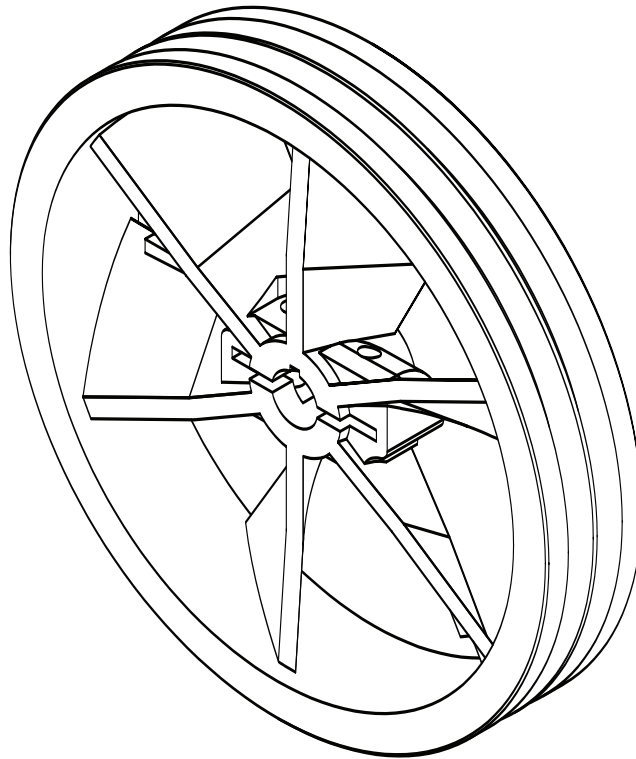

**22838**  
**14" - DUAL GROOVE**

# Clutch Options

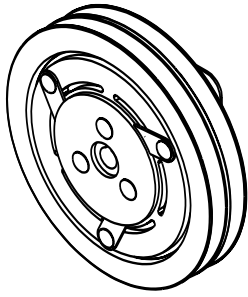

**C4705**  
**7" DUAL V**

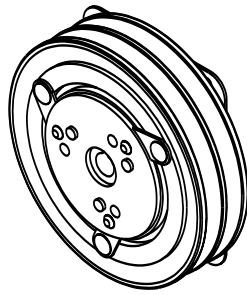

**C4704**  
**6" DUAL V**

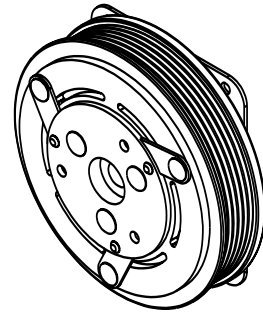

**C4723**  
**6" - 8 GROOVE**  
**SERPENTINE**

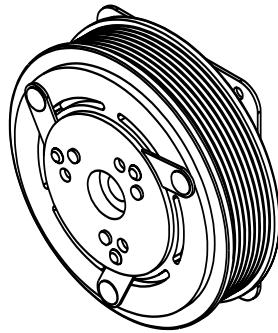

**8198**  
**6" - 8 GROOVE**  
**24V SERPENTINE**

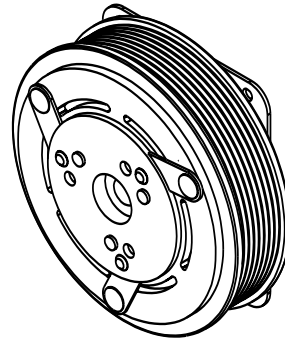

**5793**  
**6" - 8 GROOVE**  
**12V SERPENTINE**

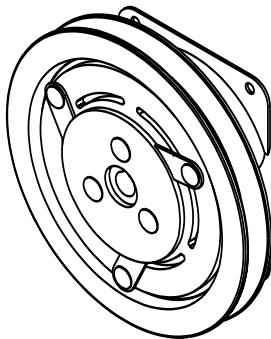

**C4775**  
**7" SINGLE V**

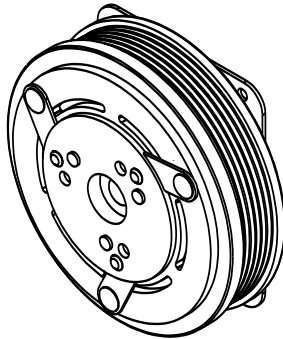

**5774**  
**6" - 6 GROOVE**  
**12V SERPENTINE**

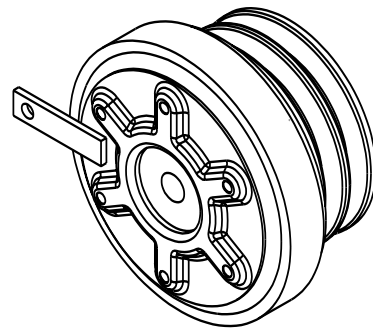

**C4762**  
**STRAIGHT BORE**

# SUH-60 Compressor Assembly

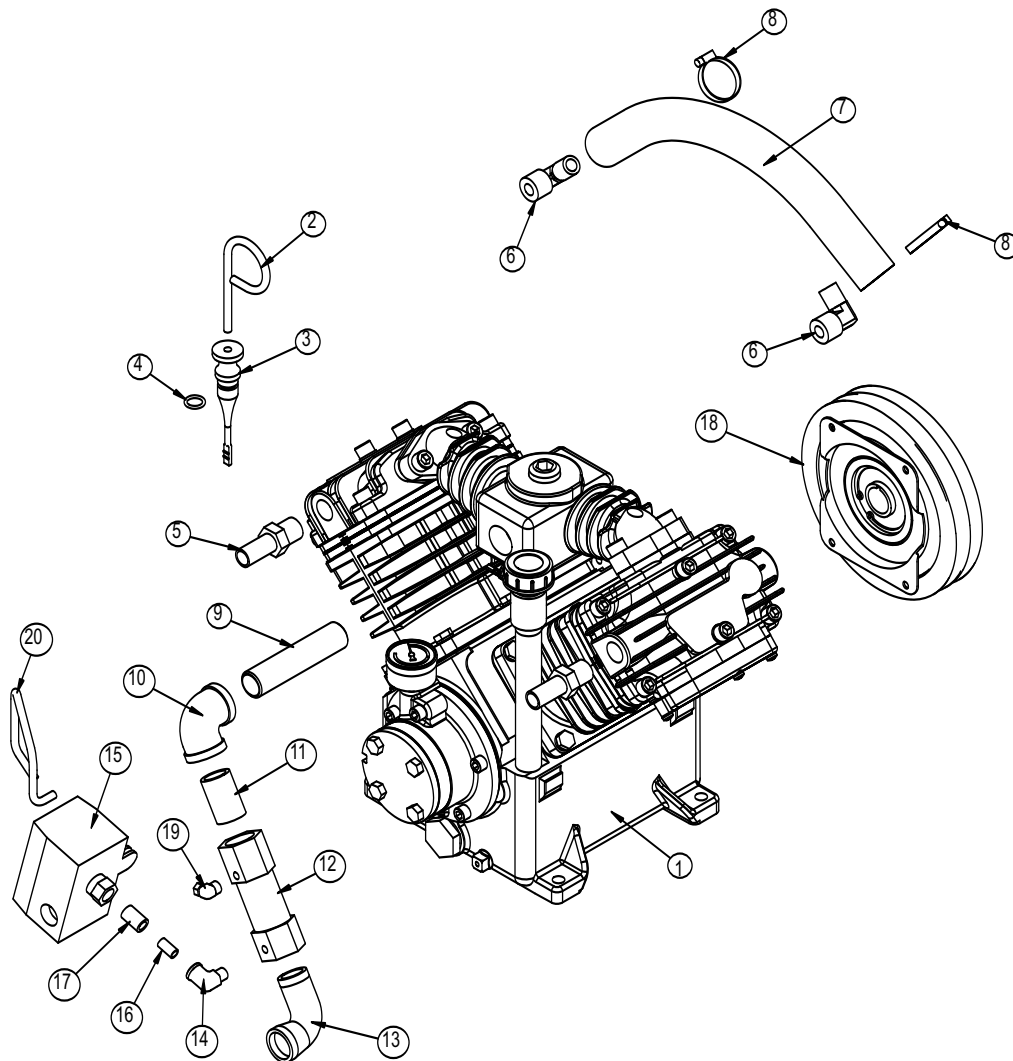

## COMPRESSOR ASSEMBLY

ITEM	PART	DESCRIPTION	QTY.
1	C4868	CPRSR V480CW16NP	1
2	22686	HANDLE DIPSTICK OIL CHECK V480	1
3	22839	DIPSTICK (V230/V360)	1
4	C0041	O'RING-112	1
5	C2279	FTG HOSE BARB 0.50 HOSE X 0.50 MNPT	2
6	C6235	FTG BRASS ELL 90 DEG A/C	2
7	25196	HOSE 0.63X12.00	1
8	C4665	HOSE CLAMP #8 SS	2
9	23878	NIPPLE 0.75X4.00 SS 304	1
10	D1266	FTG 0.75 ELBOW BRASS	1
11	D1264	FTG 0.75-CLOSE RED BRASS NIPPLE	1
12	5480	VALVE CHECK 0.75 STANDARD	1
13	D1267	FTG .75X90 DEG ST EL BRASS 44164	1
14	C4692	FTG 0.75 JIC-ML NPT 12CTX 90 DEG EL	1
15	C0863	SWITCH PRES COMPRESSOR	1
16	C5559	FTG ADAPT 1/8ML-1/4FM NPT 1404-2-4	1
17	C5576	FTG 0.25 HEX NIPPLE	1
18		SEE PAGE 15 FOR CLUTCH OPTIONS	1
19	D0240	FTG ELL 0.13 CPRSN TUBE TO NPT	1
20	25448	TUBE COPPER 0.25X9.00 SUH-60	1

# SHD-60 Compressor Assembly

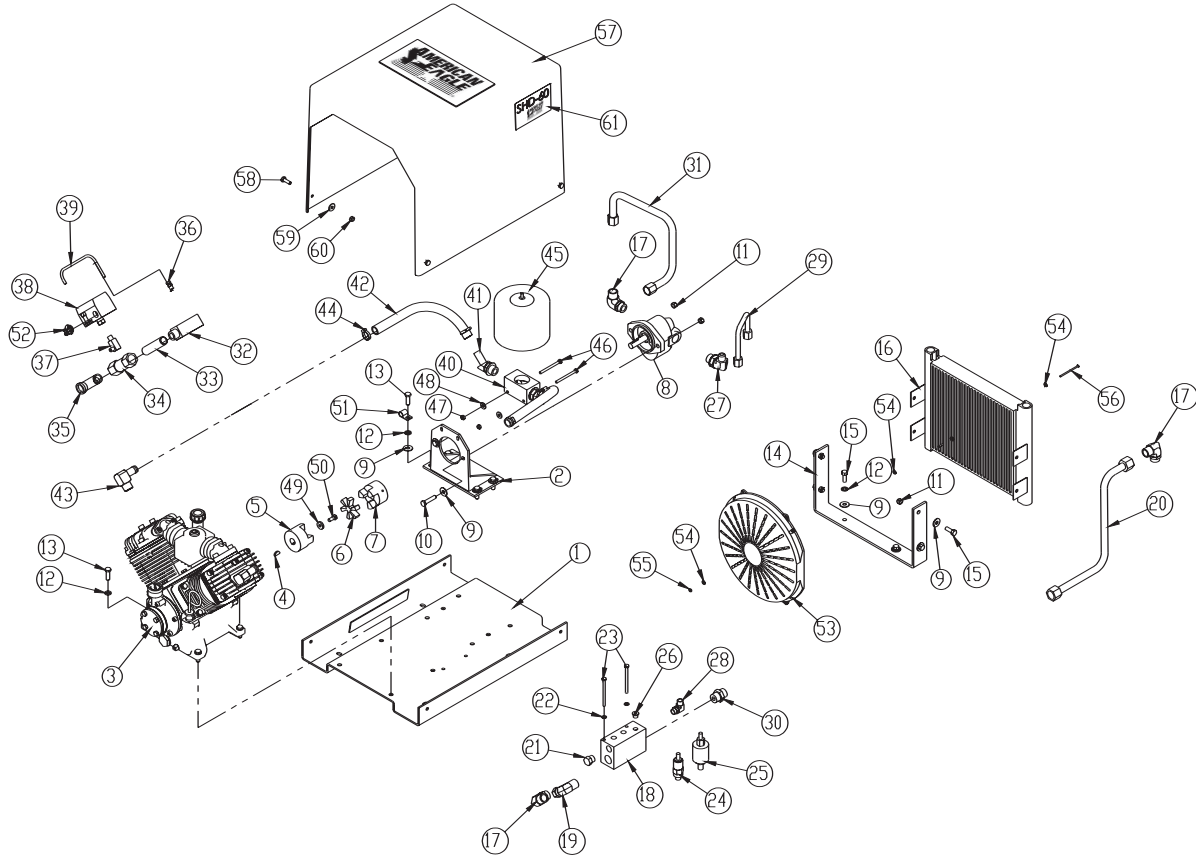

## COMPRESSOR ASSEMBLY

ITEM	PART	DESCRIPTION	QTY.	ITEM	PART	DESCRIPTION	QTY.
1	B0820	BASE WLDMNT SHD 60	1	32	8278	FTG ST L 0.75 MNPT/0.125 FNPT SPL	1
2	15967	MOTOR MNT SHD 60 & SHD 43	1	33	4581	NIPPLE 0.75X4.00 BLK PIPE	1
3	13523	CPRSR V480CT66NP	1	34	5480	VALVE CHECK 0.75 STANDARD	1
4	C4703	KEY WOODRUFF 5/32 X 3/4 #8	1	35	C6150	ST EL ML/FM PIPE 2102-12-12	1
5	C3480	COUPG HYD CPRSR TAPER	1	36	D1345	FTG CPRSN 0.12NPT/0.25 TUBE	1
6	C4779	COUPG SPIDER SUL 99 BLUE URETHANE	1	37	8276	FTG ML ELBOW 0.25 MNPT/0.125 MNPTSPL	1
7	C4781	COUPLING LOVEJOY 5/8	1	38	C0863	SWITCH PRES COMPRESSOR	1
8	C4492	MOTOR HYD SHD60 & SHD43	1	39	14267	TUBING COPPER 0.25 X 9.00	1
9	C6353	WASHER 0.38 FLAT GR8	12	40	12180	FILTER MANIFOLD SHD60 CPRSR	1
10	C0944	CAP SCR 0.38-16X1.75 HHGR5	2	41	C4794	NIPPLE O'RING 45 4603-12-12	2
11	0347	NUT 0.38-16 HH NYLOC	6	42	14600	HOSE SUCTION 0.75 X 13.00	2
12	0523	WASHER 0.38 LOCK	10	43	13638	FTG HOSE BARB 0.75 HOSE X 0.75 90DG	2
13	0335	CAP SCR 0.38-16X1.25 HHGR5	8	44	13577	CLAMP UNI 1.19 O.D. 5019	4
14	B0682	BRKT COOLER MOUNT SHD60	1	45	13529	FILTER AIR SHD60	1
15	0351	CAP SCR 0.38-16X1.00 HHGR5	6	46	0482	CAP SCR 0.25-20 X 3.00 HHGR5	2
16	C1129	COOLER OIL	1	47	0333	NUT 0.25-20 HHGR5 NYLOC	2
17	C6145	FTG 90 DEG	3	48	0340	WASHER 0.25 FLAT	4
18	C3558	MANIFOLD BLOCK SHD60	1	49	D1465	WASHER 0.31-0.178 THICK	1
19	C6379	FTG SWIVEL NUT ELBOW 12-C6X-S	1	50	C4570	CAP SCR 0.31-24X0.75 HH NF	1
20	C4766	TUBE ASM 0.75 MANIF TO CLR SHD60	1	51	C0081	CLAMP 0.50 BLK VINYL	1
21	C2322	PLUG 1/2 STR THRD 8-P5ON-S	1	52	C5616	CLAMP ROMEX 0.50	1
22	0521	WASHER 0.25 LOCK	2	53	C6359	FAN 12.00 PULL 12 VOLT	1
23	0483	CAP SCR 0.25-20 X 3.50 HHGR5	2	54	5290	WASHER #8 SAE FLAT ZP	6
24	C4914	VALVE RELIEF CP-200-1-B-0-A-C	1	55	D0076	NUT #6-32 HH NYLOC	2
25	C4499	VALVE SOLND	1	56	D0075	SCREW #6-32X2.75 RH HD MACHINE	2
26	C4961	PLUG STR HOLLOW HEX 0.38 6-HP5ON	1	57	C4695	HOOD F/G SHD60	1
27	C4671	FTG 8-12 C50X JIC 90 DEG	1	58	C0922	CAP SCR 0.31-18X1.00 HHGR5	4
28	C4501	FTG 8 C50X 90 DEG ELL	1	59	0343	WASHER 0.31 FLAT	4
29	C2297	TUBE ASM 0.50 MANIF TO MOTOR SHD60	1	60	0342	NUT 0.31-18 HH NYLOC	4
30	C4498	FTG ORB/JIC STRT CONNT 12-F5OX-S	1	61	C4500	DECAL SHD60	2
31	C4954	TUBE ASM 0.50 MANIF TO MOTOR SHD60	1				

# Hydraulics/Electrical

## SHD-60 Control Kit

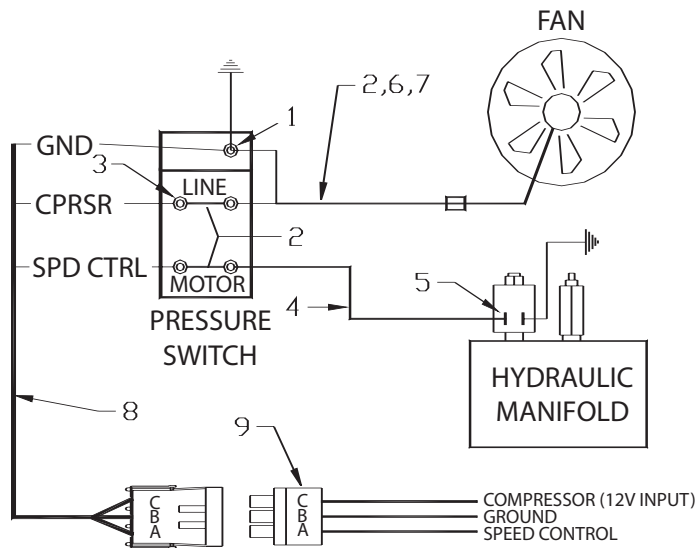

ITEM	PART No.	DESCRIPTION	QTY
1	C0072	TERMINAL RING-#10	2
2	C4691	WIRE, 14 GA BLK	1.3FT
3	C5953	TERMINAL SPADE, 14/16 #10	6
4	C6202	WIRE, DUPLEX 14-2	1.3FT
6	C6004	TERMINAL, FEMALE DISC 16/14	4
6	D1256	WIRE, 14 GA BLUE	1.3FT
7	C4131	LOOM- .38 FIBER	1FT
8	15917	WIRE HARNESS SHD60/43 COMPRESSORS	1
9	18939	WIRE HARNESS SHIPOUT PIGTAIL	1

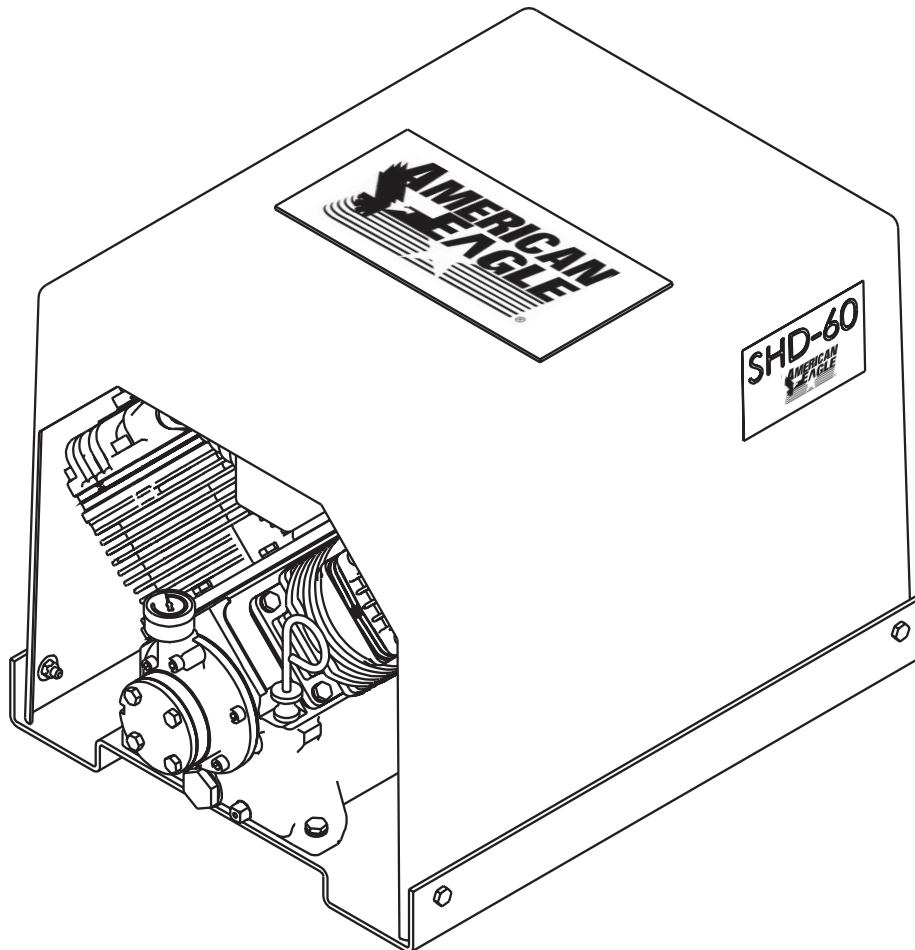

# Typical Hydraulic Circuit for Single Stage Pump with Multiple Components

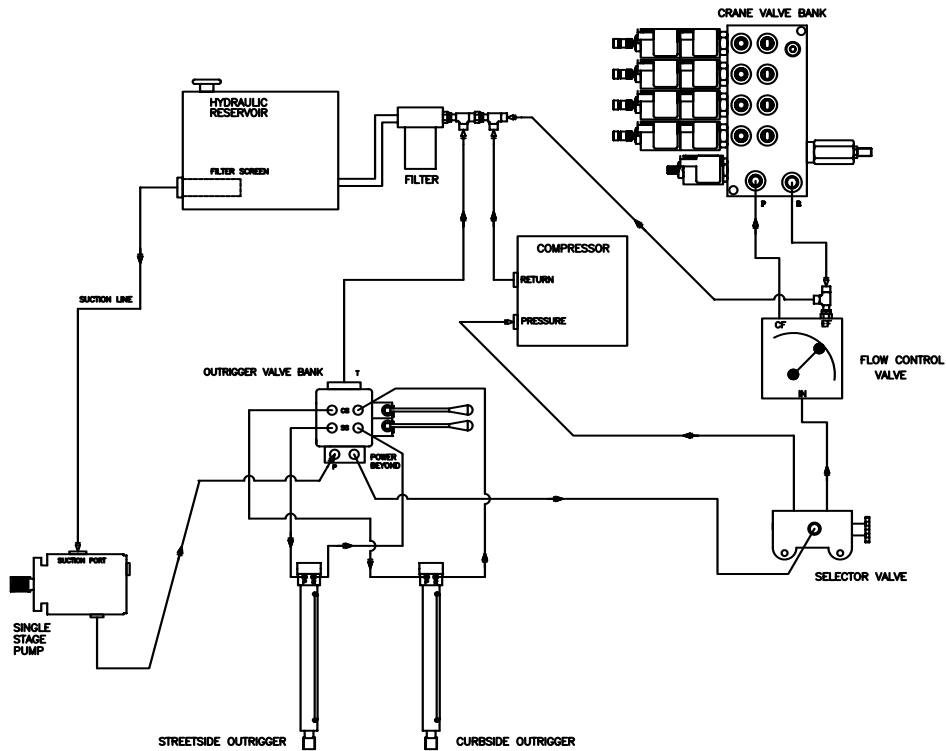

# Typical Hydraulic Circuit for Tandem (Two Part) Pump with Multiple Components

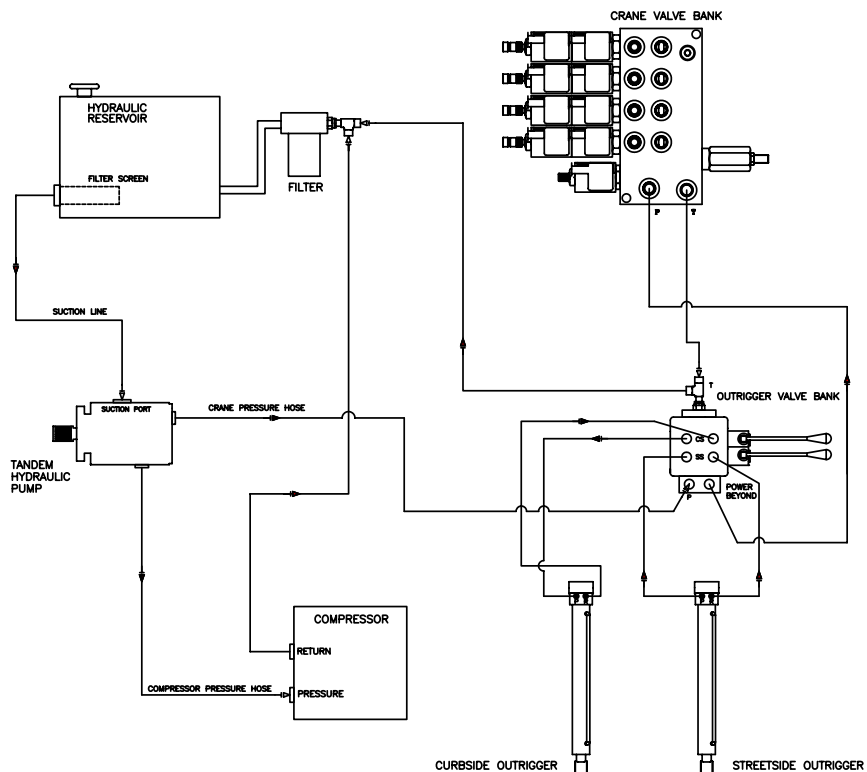

# Typical Hydraulic Circuit for Compressor with Auxiliary Cooler

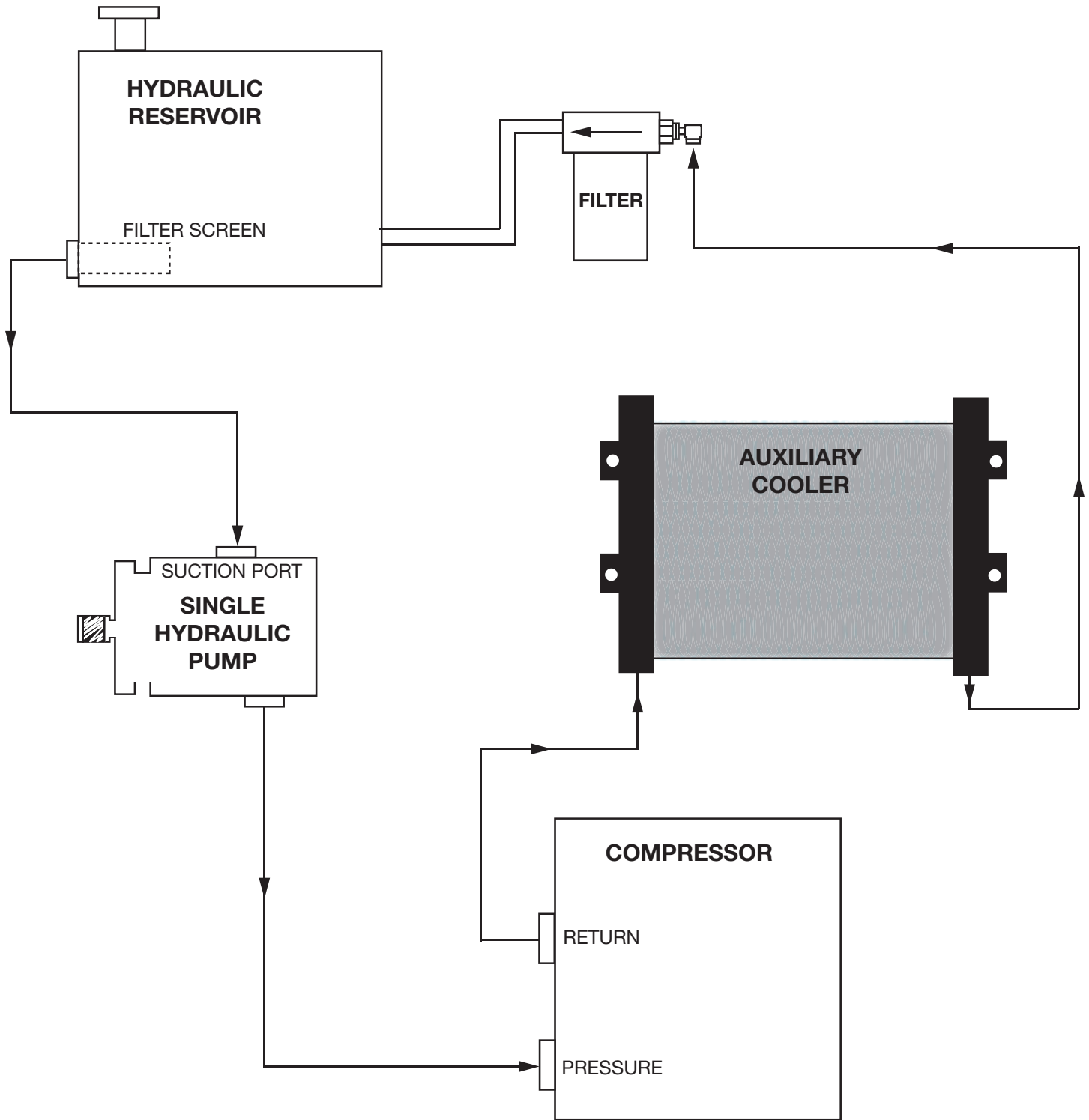



# Replacement Parts

---

**Overhaul Kit - P/N: 5380**

Consisting of: Gasket Set (1)  
Ring Set (1)  
O-Ring (2)  
Valve Plate (1)  
Bearing Oil Seal (1)  
Oil- 1 Qt  
Filter (1)

**Gasket Set Complete - P/N: C6363****Ring Set Complete - P/N: C6365****Valve Plate Assembly - P/N: D1489**

Consisting of: Valve Plate (1)  
Top Head Gasket (1)  
Bottom Head Gasket (1)

**Crankshaft With Bearings:**

Tapered Shaft - P/N: 23874

Straight Shaft - P/N: 23873

**Canister Filter - P/N: 22867**

**Call 800-321-3741 to Order**

# Troubleshooting

## General Troubleshooting

Problem	Possible Cause	Solution
Compressor runs hot	Check compressor rotation Compressor reed valves Dirty intake filter Low oil Level Check valve leaking	Check fittings on hydraulic motor Inspect, clean or replace valves Clean filter assembly Level Add oil if needed Disassemble, clean, and re-install
Compressor does not run	No 12 Volt Power to Compressor Air reservoir full Hydraulic lines not connected Couplers or hoses blocked Air load against compressor Hydraulic pump not working Hydraulic motor not working Check valve leaking	Check Fuse Drain and activate pressure switch Connect lines Locate and remove restriction Relieve air pressure Check flow and pressure settings Inspect and repair Disassemble, clean, and reinstall or replace
Compressor runs too slow	Compressor reed valves Check for hose leaks Hydraulic flow too low Hydraulic motor worn Power unit relief set too low Hydraulic system too hot Speed control not working	Inspect, clean or replace valves Tighten any hose fitting leaking Check and reset flow Replace with new motor Readjust relief valve Reservoir too small. Add cooler to system. Check power supply and readjust
Compressor will not stop	Air pressure switch set wrong Leaking hoses or fittings	Check points and setting on switch Tighten all fittings and hoses
Air output too low (air pressure okay)	Low compressor speed Air filter dirty Airlines leaking Check valve plugged	Refer to compressor too slow Clean or Replace Filters Retighten hoses Remove and clean check valve
Compressor cycles (air not being used)	Leaks in air line Air pressure switch set wrong Dirt in solenoid valve	Tighten hoses and fittings Check cut-in and cutout settings Remove and clean
Air Output low (Air Pressure Low)	Dirty air filter Intake reed valves malfunction  Insufficient torque on head bolts	Inspect and clean filter If air back-flows from air filter, reed valve is faulty and needs to be replaced. Tighten bolts to required torque
Air pressure too low	Air pressure switch set wrong Air line leak Air consumption exceeds Compressor capacity Intake or exhaust valves damaged	Readjust high pressure setting Inspect and tighten loose hoses Check air demand for items using the air supply  Inspect and replace
Air pressure too high	Pressure switch not operating Internal contamination Pressure switch not adjusted	Inspect and clean Inspect and clean Readjust to lower pressure
High crankcase oil usage	Oil level too high Oil leaks Piston rings worn or broken	Check oil level and drain if needed Inspect and repair gaskets or seals Replace rings
Blowing oil from crankcase breather	Blown head gasket Piston rings worn or broken Oil level in crankcase too high Hole in piston	Replace gasket Replace rings Check oil level and drain Replace piston
No lubricating oil pressure	Air lock in oil pump  No oil in crankcase Pump suction blocked	Loosen oil gauge while compressor is running. When oil begins to flow from fitting, tighten oil gauge. Check oil level and add Remove oil intake plug and inspect intake and screen. Clean blockage.

## SHD-60 Troubleshooting

If symptoms of poor performance develop, the following chart can be used as a guide to investigate and correct the problem. When diagnosing faults in operations of the air compressor, always check that the hydraulic power source is supplying the correct hydraulic flow and pressure that is listed in the compressor specification section of this manual. **Note: To Operate, the American Eagle SHD-60 Compressor needs 10 GPM and 1800 PSI System Pressure.**

Problem	Possible Cause	Solution
Compressor locks up at 110 psi and higher while under load:  <b>Note: When checking hydraulic pump flow, make sure the air tank is closed and the compressor is running.</b>	Weak Hydraulic Motor.	If the Hydraulic pump is supplying the recommended amount of fluid to the hydraulic motor, replace the hydraulic motor.
	Faulty Hydraulic Pump.	If the pump pressure is below the recommended GPM, replace the Hydraulic pump if necessary.
	Oil Pressure is low.	If the oil pressure gauge is reading in the red area, the oil pressure is low. See the Low Oil Pressure entry in this troubleshooting section.
Compressor will not operate:	Air receiver is full.	Drain and activate pressure switch.
	12 Volt power is not going to the line side of the pressure switch.	If there is no power going to the line side of the pressure switch, trace the wire back to the power source.
	Faulty Pressure Switch.	If there is no power going to the solenoid valve, replace the pressure switch.
	Hydraulic Lines not installed correctly.	Reinstall hydraulic lines.
	Air Couplers or hoses are blocked.	Locate and remove restriction.
	Inline Check-Valve is leaking.	Disassemble, clean, and reinstall or replace.
	Faulty Solenoid Valve.	If there is power going to the pressure switch, press down on the solenoid valve bypass button. If the compressor starts to operate, replace the solenoid valve.
	Compressor is locked up.	Remove the coupler and lovejoy between the compressor pump and the hydraulic motor. Turn the compressor over by hand. If the compressor turns over freely, the pump is ok. This indicates there is a possible hydraulic problem.
	Hydraulic motor malfunctioning.	Inspect and repair.
Hydraulic pump malfunctioning.	Check flow and pressure settings.	

Problem	Possible Cause	Solution
Compressor runs hot:	Dirty intake filter.	Clean filter assembly.
	Low oil Level.	Add oil if needed.
	Inline check-valve leaking.	Disassemble, clean, and re-install.
	Blown Head or Reed Valve Gasket.	Replace Gasket.
	Malfunctioning reed valve.	Inspect, clean or replace valves.
Compressor runs too slow:	Speed control not working.	Check power supply and readjust.
	Check for air hose leaks.	Tighten any hose fitting leaking.
	Hydraulic system too hot.	Reservoir too small. Add cooler to system.
	Power unit relief set too low.	Readjust relief valve.
	Hydraulic motor worn.	Replace with new motor.
	Hydraulic flow too low.	Check and reset flow.
	Malfunctioning reed valves.	Inspect, clean, or replace valves.
Compressor hesitates or stumbles at restart (115 PSI):  <b>Note: Compressor kicks out at 150 PSI and kicks back in at 115 PSI</b>	Weak Hydraulic Pump.	If the hydraulic pump pressure is below the recommended GPM to the hydraulic motor, the hydraulic pump could be weak and needs to be replaced.
	Weak Hydraulic Motor.	If the hydraulic pump is supplying the recommended GPM to the hydraulic motor, the hydraulic motor could be weak and needs to be replaced.
No lubricating oil pressure:	No oil in crankcase.	Add oil.
	Pump suction blocked.	Remove oil intake plug and inspect intake screen. Clean blockage.
	Air lock in oil pump.	Loosen oil gauge while the compressor is running. When oil begins to flow, tighten the gauge.
	Oil pump pin is broken.	Replace pin.
	Malfunctioning oil pump.	If the oil pressure gauge indicator is reading in the red area, use a 1/4" lock washer and point it flat. Remove the oil pump housing cover and place the lock washer inside the oil pump transfer bushing so it is between the pump spring and the transfer bushing. If oil pressure is still low, add one more lock washer. If two lock washers don't increase the oil pressure, replace the oil pump.

Problem	Possible Cause	
Air Output low: (Air Pressure Low)	Dirty air filter.	Inspect and clean filter.
	Insufficient torque on head bolts.	Tighten bolts to required torque.
	Intake reed valves malfunction.	If air back-flows from air filter, reed valve is faulty and needs to be replaced.
Air pressure too low:	Air line leaking.	Inspect and tighten loose hoses.
	Air consumption exceeds Compressor capacity.	Check air demand for items using the air supply.
	Air pressure switch set incorrectly.	Readjust high pressure setting.
	Intake or exhaust reed valves damaged.	Inspect and replace.
Air pressure too high:	Pressure switch not functioning correctly.	Inspect and clean.
	Internal contamination.	Inspect and clean.
	Pressure switch not adjusted correctly.	Readjust to lower pressure.
High crankcase oil usage:	External oil leaks.	Inspect and repair gaskets or seals.
	Oil level too high.	Check oil level and drain if needed.
	Piston rings worn or broken.	Replace rings.
Blowing oil from crankcase breather:	Oil level in crankcase too high.	Check oil level and drain.
	Blown head gasket.	Replace gasket.
	Piston rings worn or broken.	Replace ring.
	Hole in piston.	Replace piston.
Compressor will not stop:	Air pressure switch set incorrectly .	Check points and setting on switch.
	Leaking air hoses or fittings.	Tighten all fittings and hoses.



### Limited Warranty Statement

American Eagle warrants products designed and manufactured by Stellar to be free from defects in material and workmanship under proper use and maintenance. Products must be installed and operated in accordance with Stellar's written instructions and capacities. The warranty period shall cover the following:

Twelve (12) month warranty on parts and  
Twelve (12) month repair labor

The warranty period shall begin from the date recorded by American Eagle as the in-service date. This date will be derived from the completed warranty registration card. In the event a warranty registration card is not received by American Eagle, the factory ship date will be used. New compressors will be issued on all returns within 90 days of this factory ship date. After 90 days, American Eagle reserves the right to issue remanufactured compressors. Regardless of in-service date, warranty coverage does not extend beyond twenty-four (24) months from date of manufacture.

American Eagle's obligation under this warranty is limited to, and the sole remedy for any such defect shall be, the repair and/or replacement (at American Eagle's option) of the unaltered part and/or component in question. American Eagle after-sales service personnel must be notified by telephone, fax, or letter of any warranty-applicable damage within fourteen (14) days of its occurrence. If at all possible, American Eagle will ship the replacement part within 24-hours of notification by the most economical, yet expedient, means possible. Expedited freight delivery will be at the expense of the owner.

Warranty claims must be submitted and shall be processed in accordance with American Eagle's established warranty claim procedure. American Eagle after-sales service personnel must be contacted prior to any warranty claim. A return materials authorization (RMA) account number must be issued to the claiming party prior to the return of any warranty parts. Parts returned without prior authorization will not be recognized for warranty consideration. All damaged parts must be returned to American Eagle freight prepaid; freight collect returns will be refused. Freight reimbursement of returned parts will be considered as part of the warranty claim.

Warranty service will be performed by any American Eagle new equipment distributor, or by any American Eagle-recognized service center authorized to service the type of product involved, or by the American Eagle factory in the event of a direct sale. At the time of requesting warranty service, the owner must present evidence of date of delivery of the product. The owner shall be obligated to pay for any overtime labor requested of the servicing company by the owner, any field service call charges, and any towing and/or transportation charges associated with moving the equipment to the designated repair/service provider.

All obligations of American Eagle and its authorized dealers and service providers shall be voided if someone other than an authorized American Eagle dealer provides other than routine maintenance service without prior written approval from American Eagle. In the case repair work is performed on a American Eagle-manufactured product, original American Eagle parts must be used to keep the warranty in force. The warranty may also be voided if the product is modified or altered in any way not approved, in writing, by American Eagle.

The owner/operator is responsible for furnishing proof of the date of original purchase of the American Eagle product in question. Warranty registration is the ultimate responsibility of the owner and may be accomplished by the completion and return of the American Eagle product registration card provided with the product. If the owner is not sure of registration, he is encouraged to contact American Eagle at the address below to confirm registration of the product in question. This warranty covers only defective material and workmanship. It does not cover depreciation or damage caused by normal wear and tear, accident, mishap, untrained operators, or improper or unintended use. The owner has the obligation of performing routine care and maintenance duties as stated in American Eagle's written instructions, recommendations, and specifications. Any damage resulting from owner/operator failure to perform such duties shall void the coverage of this warranty. The owner will pay the cost of labor and supplies associated with routine maintenance.

The only remedies the owner has in connection with the breach or performance of any warranty on the American Eagle product specified are those set above. In no event will American Eagle, the American Eagle distributor/dealer, or any company affiliated with American Eagle be liable for business interruptions, costs of delay, or for any special, indirect, incidental, or consequential costs or damages. Such costs may include, but are not limited to, loss of time, loss of revenue, loss of use, wages, salaries, commissions, lodging, meals, towing, hydraulic fluid, or any other incidental cost.

All products purchased by American Eagle from outside vendors shall be covered by the warranty offered by that respective manufacturer only. American Eagle does not participate in, or obligate itself to, any such warranty.

American Eagle reserves the right to make changes in design or improvement upon its products without imposing upon itself the same upon its products theretofore manufactured.

This warranty will apply to all American Eagle Drawer Sets and Compressed Air Systems shipped from American Eagle's factory after July 1, 2005. The warranty is for the use of the original owner only and is not transferable without prior written permission from American Eagle.

THIS WARRANTY IS EXPRESSLY IN LIEU OF ANY OTHER WARRANTIES, EXPRESS OR IMPLIED, INCLUDING ANY WARRANTY OF MERCHANTABILITY OR FITNESS FOR A PARTICULAR PURPOSE. REMEDIES UNDER THIS WARRANTY ARE LIMITED TO THE PROVISION OF MATERIAL AND SERVICES, AS SPECIFIED HEREIN. AMERICAN EAGLE INDUSTRIES, INC. IS NOT RESPONSIBLE FOR INCIDENTAL OR CONSEQUENTIAL DAMAGES.

Revision Date: March 2006

Document Number: 37042