

## **Operating Instructions**

### **Two component proportioning valve SKW-E**

**Sterling Material Processing**

5200 West Clinton Ave.

Milwaukee, WI 53223

Telephone: (414) 354-0970

Fax: (414) 354-6421

www.sterlco.com

**Technical service:**

Service department

Telephone: **(800) 423-3183**

**Edition: 08/02**

**Confirmation number:** \_\_\_\_\_

These operating instructions are for:*	
(* Please fill in personally)	
Serial number:	_____
Built in:	_____
Date of delivery:	_____
Number of delivery:	_____
Date of commissioning:	_____
Location:	_____
Group of machines:	_____

Sterling Material Processing retains all rights to change the information in these operating instructions at any time without notice.

We assume no liability for any errors or direct or indirect damage resulting in context with these operating instructions.

Copying, translation or publication in any form except for personal use of purchaser requires approval from Sterling Material Processing.

All rights reserved.

## Please note that our address and phone information has changed. Please reference this page for updated contact information.



These manuals are obsolete and are provided only for their technical information, data and capacities. Portions of these manuals detailing procedures or precautions in the operation, inspection, maintenance and repair of the products may be inadequate, inaccurate, and/or incomplete and shouldn't be relied upon. Please contact the ACS Group for more current information about these manuals and their warnings and precautions.

### Parts and Service Department

The ACS Customer Service Group will provide your company with genuine OEM quality parts manufactured to engineering design specifications, which will maximize your equipment's performance and efficiency. To assist in expediting your phone or fax order, please have the model and serial number of your unit when you contact us. A customer replacement parts list is included in this manual for your convenience. ACS welcomes inquiries on all your parts needs and is dedicated to providing excellent customer service.

#### For immediate assistance, please contact:

- North, Central and South America, 8am – 5pm CST +1 (800) 483-3919 for drying, conveying, heating and cooling and automation. For size reduction: +1 (800) 229-2919.  
North America, emergencies after 5pm CST (847) 439-5855  
**North America email: [acsuscanadacustserv@corpemail.com](mailto:acsuscanadacustserv@corpemail.com)**
- Mexico, Central & South America  
**Email: [acslatinamericacustserv@corpemail.com](mailto:acslatinamericacustserv@corpemail.com)**
- Europe, Middle East & Africa +48 22 390 9720  
**Email: [acseuropecustserv@corpemail.com](mailto:acseuropecustserv@corpemail.com)**
- India +91 21 35329112  
**Email: [acsindiacustserv@corpemail.com](mailto:acsindiacustserv@corpemail.com)**
- Asia/Australia +86 512 8717 1919  
**Email: [acsasiacustserv@corpemail.com](mailto:acsasiacustserv@corpemail.com)**

### Sales and Contracting Department

Our products are sold by a worldwide network of independent sales representatives. Contact our Sales Department for the name of the sales representative nearest you.

Let us install your system. The Contract Department offers any or all of these services: project planning; system packages including drawings; equipment, labor, and construction materials; and union or non-union installations.

#### For assistance with your sales or system contracting needs please Call:

North, Central and South America +1 (262) 641-8600 or +1 (847) 273-7700 Monday–Friday, 8am–5pm CST

Europe/Middle East/Africa +48 22 390 9720

India +91 21 35329112

Asia/Australia +86 512 8717 1919

#### Facilities:

ACS offers facilities around the world to service you no matter where you are located. For more information, please visit us at [www.acscorporate.com](http://www.acscorporate.com)

United States:

#### ACS Schaumburg – Corporate Offices

1100 E. Woodfield Road  
Suite 588  
Schaumburg, IL 60173  
Phone: + 1 847 273 7700  
Fax: + 1 847 273 7804

#### ACS New Berlin – Manufacturing Facility

2900 S. 160<sup>th</sup> Street  
New Berlin, WI 53151  
Phone : +1 262 641 8600  
Fax: + 1 262 641 8653

Asia/Australia:

#### ACS Suzhou

109 Xingpu Road SIP  
Suzhou, China 215126  
Phone: + 86 8717 1919  
Fax: +86 512 8717 1916

Europe/Middle East/Africa:

#### ACS Warsaw

Ul. Działkowa 115  
02-234 Warszawa  
Phone: + 48 22 390 9720  
Fax: +48 22 390 9724

India

#### ACS India

Gat No. 191/1, Sandbhor Complex  
Mhalunge, Chakan, Tal Khed,  
Dist. Pune 410501, India  
Phone: +91 21 35329112  
Fax: + 91 20 40147576

## Table of contents

<b>1. General instructions (Version: 64.10-0251GB01 08/02)</b> .....	<b>1-1</b>
1.1. Warnings and symbols .....	1-2
1.2. Explanations and information .....	1-3
1.3. Legal basis .....	1-3
1.4. Fields of applications .....	1-3
1.5. Notes on usage .....	1-3
<b>2. Safety instructions (Version: 64.10-0251GB01 08/02)</b> .....	<b>2-1</b>
2.1. For your safety .....	2-2
2.2. For the operating safety of the equipment .....	2-5
<b>3. Start-up (Version: 64.10-0251GB01 08/02)</b> .....	<b>3-1</b>
3.1. Adjusting the conveying ratio .....	3-2
3.2. Determining the switching cycle duration .....	3-3
3.3. Setting the switching cycles .....	3-5
<b>4. Error and error correction (Version: 64.10-0251GB01 08/02)</b> .....	<b>4-1</b>
<b>5. Maintenance (Version: 64.10-0251GB01 08/02)</b> .....	<b>5-1</b>
5.1. Maintenance intervals .....	5-2
<b>6. Functional description (Version: 64.10-0251D01 08/02)</b> .....	<b>6-1</b>
6.1. General information .....	6-2
6.2. Control .....	6-2
6.2.1. Version 1 .....	6-2
6.2.2. Version 2 (optional) .....	6-4
<b>7. Transport, Assembly and Storage (Version: 64.10-0251GB01 08/02)</b> .....	<b>7-1</b>
7.1. Transport and Packing .....	7-2
7.2. Assembly .....	7-2
7.3. Storage .....	7-2

**8. Installation instructions (Version: 64.10-0251GB01 08/02)..... 8-1**

- 8.1. Installation..... 8-2
- 8.2. Electrical connection ..... 8-3
  - 8.2.1. Sterling Single Conveyor Unit with 230 V-Output Port ..... 8-3
  - 8.2.2. Sterling Single Conveyor Unit with 24 V-Output Port ..... 8-4
  - 8.2.3. Connection to a conveyance control system ..... 8-4
- 8.3. Compressed air supply ..... 8-5

**9. Technical data (Version: 64.10-0251GB01 08/02) ..... 9-1**

**10. Spare Parts List (Version: 64.10-0251GB01 08/02)..... 10-1**

- 10.1. SKW-E..... 10-2
- 10.2. Accessories..... 10-2

**11. Accessories (Version: 64.10-0251GB01 08/02) ..... 11-1**

- Table Conveying time / Number of switching cycles
- 
- 

**12. Electrical manual (Version: 64.10-0 251GB01 08/02) ..... 12-1**

- Connection diagram no.: -----
- Currently not available; will be delivered at a later date !

## 1. General instructions

Version: 64.10-0251GB01 08/02



These instructions apply to all persons within the range of action of the equipment.

These operating instructions are to be used by all persons assigned activities connected with the equipment.

## 1.1. Warnings and symbols

The following warnings and symbols are used in these operating instructions:



This symbol indicates danger to life! Fatal or serious injury is possible if the corresponding instructions, regulations or warnings are not observed.



This symbol indicates that serious injury is possible if the corresponding instructions, regulations or warnings are not observed.



This symbol indicates that extensive damage to equipment is possible if the corresponding instructions, regulations or warnings are not observed.



This symbol indicates information important for becoming familiar with the equipment, i.e. technical correlations.



This symbol indicates that a technical term is explained at this point.



---

## 1.2. Explanations and information

Various terms and designations are used in these operating instructions to ensure clarity. Therefore please note that the terms used in the text stand for the corresponding explanations listed below.

- **Equipment**  
"Equipment" can mean an individual unit, a machine or an installation.
- **Operating personnel**  
The "operating personnel" are persons operating the equipment on their own responsibility or according to instructions.
- **Operator**  
The "operator" of the equipment (production manager, foreman, etc.) is the person responsible for all production sequences. The operator instructs the operating personnel of what is to be done.
- **Operating instructions**  
The "operating instructions" describe the interaction of the equipment, production sequences or methods. The operating instructions must be compiled by the operator of the equipment.
- **Equipment foreman**  
When several operating personnel work on one machine, the "equipment foreman" coordinates the sequences. The equipment foreman must be appointed by the operator.
- **Trained personnel**  
"Trained personnel" are persons who, due to their training, are authorized to carry out the required work.

## 1.3. Legal basis

See "Manufacturer's Certificate" resp. "Certificate of Conformity".

## 1.4. Fields of applications

Free adjustable regrind processing in conjunction with a conveying system. Material switching works pneumatically by a high reliable push-piston. During every conveying cycle, the SKW-E pulses rapidly between both materials, which minimizes layering. The conveying ratio can be preselected between 0 and 100 %.

## 1.5. Notes on usage

- Experienced operators can begin directly with the chapter on "Start-up" if the unit has been properly installed.
- If the unit has not been installed yet, observe the instructions in the chapters "Transport, Assembly and Storage" and "Assembly Instructions".

---

## 2. Safety instructions

Version: 64.10-0251GB01 08/02



These safety instructions apply to all persons within the range of action of the equipment.

Please inform all persons within the range of action of the equipment of the direct and indirect hazards connected with the equipment.

These operating instructions are to be used by all persons assigned activities connected with the equipment.

Knowledge of the English language is prerequisite.

Ensure in each case that the operating personnel are familiar with the operating instructions and the function of the equipment.

## 2.1. For your safety

### General

The operating personnel of this equipment must be at least 16 years old.

Please read these operating instructions carefully before taking into operation for the first time. Contact us should questions arise. This avoids injury and damage to equipment!

These operating instructions must be kept available at all times at the place of operation of the equipment. Improper operation results in danger of accidents!

Please note that, for reasons of clarity, not all conceivable cases regarding operation or maintenance of the equipment can be covered in these operating instructions.

Please observe all safety instructions and warnings on the equipment. This avoids injury and damage to equipment!

All work on the equipment is to be carried out by persons whose qualifications are specified in the pertaining chapters of the operating instructions. Improper operation results in danger of accidents!

The proper working clothes are to be worn during any work on the equipment. This avoids injury!

The local regulations and requirements pertaining to this equipment must be observed.

Disconnect electrical components from the mains supply before work is carried out on these components. Caution: Danger to life through electrical shock!

Compile detailed operating instructions based on these Operating instructions for the sequence of procedures to be carried out on this equipment. Improper operation results in danger of accidents!

Please note that sound levels exceeding 85 db(A) may in the long term damage your health. Use the appropriate ear muffs. This avoids impairment of hearing!

**Assembly**

Compare the connected loads with those of the mains supply. Danger of injury through electrical shock!

When using lifting gear, please observe the pertaining regulations. Caution: Danger of accidents!

Do not modify, add other equipment or change the design of the equipment without the approval of the manufacturer. Caution: Danger of accidents!

Attachments not supplied by Sterling must be manufactured in accordance with safety regulation EN 294. Danger of accidents!

The equipment may only be operated when all the associated components are properly connected up and in accordance with the relevant regulations. This avoids injury and damage to equipment!

Operate the device only if all its components are grounded. Danger: accident through electrical shock!

Solid particles and dust must be separated before entry to the vacuum generator. This avoids damage to equipment!

If PVC hoses are used for conveying, they must be grounded. This avoids injury and damage to equipment!

An acoustic cover should be installed when vacuum generators are located in work rooms. This avoids impairment of hearing!

### **Operation**

Appoint an equipment foreman to be responsible for the equipment.

Ensure that the operating personnel are provided detailed instruction in the operation of the equipment. Improper operation results in danger of accidents!

When the main switch is switched off for reasons pertaining to safety, it must be secured against unauthorized activation. Caution: Danger of accidents!

Repair work may be carried out by trained personnel only. Caution: Danger of accidents!

Never operate the equipment when partially dismantled! Danger! Limbs may be caught in machinery! Electric shock!

In case of malfunction, shut down the equipment immediately. Have malfunctions corrected immediately. Danger of accidents!

The equipment is intended only for conveying granulated plastics and regrinds. Any other or additional use is contrary to specifications.

This equipment is not suitable for food processing.

The safety instructions of the connected machines must be followed.

The equipment may only be operated in conjunction with a conveying unit / system. Caution: Danger of accidents!

The unit may only be operated with mounted conveying lines.

### **Maintenance**

Before starting maintenance work, appoint a supervisor.

Inform the responsible personnel before maintenance work on the system is started. Caution: Danger of accidents!

Disconnect the equipment from mains supply before starting maintenance procedures to ensure that it cannot be switched on unintentionally. Caution: Danger of accidents!

All pipes, hoses and screwed connections should be checked regularly for leaks and damage. Any faults which arise should be corrected immediately. Danger of accidents!

Depressurise all compressed air piping before starting maintenance work. Danger of accidents!

## 2.2. For the operating safety of the equipment

Never change settings if the consequences are not precisely known.

Use only original Sterling spare parts.

Please observe the maintenance schedule.

Keep record of all maintenance and repair work.

Please note that electronic components may be damaged by static discharge.

Check all electrical connections for proper fit before the equipment is taken into operation for the first time and at regular intervals.

Please ensure that the permitted operation temperature lies between 0 °C and +45 °C (32 to +113 °F).

Please ensure that the permitted storage temperature lies between -25 °C and +55 °C (-13 to +131 °F).

Note down all data which you have entered into the control system.

Please ensure that all plugs are correctly plugged in.

The operating instructions of the connected machines must be followed.

Operate the device only if all its components are grounded.

Never adjust sensors without exact knowledge of their function.

Please note that a compressed air supply is required for the operation of the unit.

Never set a higher operating pressure than 6 bar (87.02 PSI) for the unit (system overpressure).

Align the suction tubes correctly.

Please note that the set conveying ratio determines the conveying time.

The equipment may only be operated in conjunction with a conveying unit / system.

The unit may only be operated with mounted conveying lines.

If the solenoid valve is tension free the push-piston is extended and the virgin material intake port opened.

### 3. Start-up

Version: 64.10-0251GB01 08/02



This chapter is intended for operating personnel.

Prerequisite for this chapter is general knowledge of the operation of conveying units.

Also prerequisite for this chapter is that the functional description has been read and understood.

Ensure in each case that the operating personnel are sufficiently informed.



The unit may only be operated with mounted conveying lines.



Check the compressed air supply (max. 6 bar system overpressure).

Check the connections of the conveying lines.

Check the suction pipe adjustment.



The unit may only be operated in conjunction with a conveying unit / conveying system.

### 3.1. Adjusting the conveying ratio

Adjust the conveying ratio according to your specific requirements.

#### Version 1

By means of the arrow key, set the percentage of component 1 (= regrind).



#### Example

Desired conveying ratio: 40 % regrind and 60 % raw material.

Press the arrow key until "40" appears on the display.



When conveying poorly flowing components, set higher values.

#### Version 2 (optional)

Set the percentage of component 1 (= regrind) by means of the control system of the conveying control.

Observe the operating manual of the conveying control.



### 3.2. Determining the switching cycle duration

Measure the conveying time of the corresponding hopper.

Consult the table (see chapter accessories).

Look for the value in the column "conveying time".

Select a number of switching cycles.

Press the percentage key.

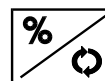

By means of the arrow key, select the desired switching cycle.

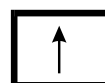

Carry through one conveying procedure.

If you are not satisfied with the result, check the setting and correct, if necessary.



No thick layers may form in the hopper loader.

#### Example

Conveying time: 50 s

Conveying ratio: 40 % regrind, 60 % virgin material

Setting options for a conveying time of 50 s:

Conveying time (seconds)	Number of switching cycles at cycle period (seconds)									
	50	45	40	35	30	25	20	15	10	5
50	1	1,1	1,3	1,4	1,7	2	2,5	3,3	5	10

a.) Setting 50 seconds = 1 switching cycle per conveying procedure

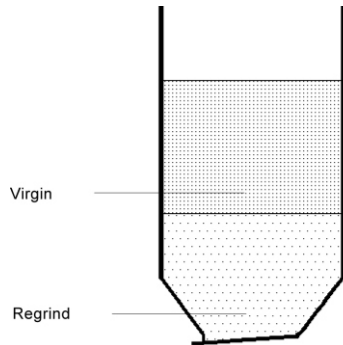

The SKW-E switches twice; it conveys regrind for 20 seconds and virgin material for 30 seconds.

**Significant zoning.**

b.) Setting 10 = 5 switching cycles per conveying procedure

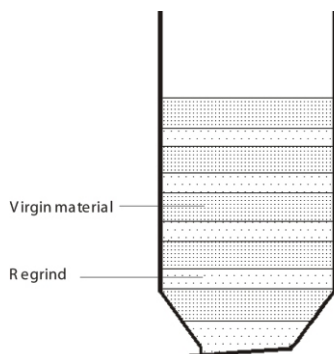

The SKW-E switches ten times; it conveys regrind for 4 seconds and virgin material for 6 seconds.

**Insignificant zoning.**

c.) Setting 5 = 10 switching cycles per conveying cycle

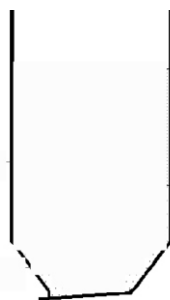

The SKW-E switches 20 times; it conveys regrind for 2 seconds and virgin material for 3 seconds. This process is repeated 10 times.

**No correct conveyance possible.**

With a conveying time of 2 to 3 seconds the material cannot be conveyed properly.

### 3.3. Setting the switching cycles

#### Version 1

Press the percentage key.

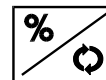

By means of the arrow key, set the determined switching cycle.



Check the result.

If the result is not satisfactory, correct the setting.



If there are too many switching cycles, proper conveying is not possible.

#### Version 2 (optional)

Set the determined value by means of the control system of the conveying control.

Observe the operating manual of the conveying control.

Check the result.

If the result is not satisfactory, correct the setting.

## 4. Error and error correction

Version: 64.10-0251GB01 08/02



This chapter is intended for the operating personnel of the equipment.

Prerequisite for this chapter is general knowledge of the operation of conveying units.

The “Start-up” description must have been read and understood.

Ensure in each case that the operating personnel are sufficiently informed.



The control unit displays no error messages.

## 5. Maintenance

Version: 64.10-0251GB01 08/02



This chapter is intended for persons with skills in electrical and mechanical areas due to their training, experience and received instructions.

Personnel using the instructions in this chapter must be instructed of the regulations for the prevention of accidents, the operating conditions and safety regulations and their implementation.

Ensure in each case that the personnel are informed accordingly.

For maintenance work taking place at heights of over approx. 1829 mm (6 ft.), use only ladders or similar equipment and working platforms intended for this purpose. At greater heights, the proper equipment for protection against falling must be worn.

Use only suitable lifting gear which is in proper working order and load suspension devices with sufficient carrying capacity. Do not stand or work under suspended loads!

Ensure that the electric motors/switch cabinets are sufficiently protected against moisture.

Use only suitable workshop equipment.

Before starting maintenance work, appoint a supervisor.

Inform the responsible personnel before maintenance work on the system is started.

Never operate the equipment when partially dismantled.

All maintenance and repair work not described in this chapter may only be carried out by Sterling service personnel or authorized personnel (appointed by Sterling).



Disconnect the equipment from mains supply before starting maintenance procedures to ensure that it cannot be switched on unintentionally.

Depressurize all compressed air piping of the equipment before starting maintenance work.



Please observe the maintenance intervals.

Before starting maintenance work, clean the equipment of oil, fuel or lubricants.

Ensure that materials and incidentals required for operation as well as spare parts are disposed of properly and in an environmentally sound manner.

Use only original Sterling spare parts.

Keep record of all maintenance and repair procedures.

## 5.1. Maintenance intervals

- Daily:
- Check warning signs on equipment for good legibility and completeness.
  - Check the oil level in the oiler.
  - Empty the water separator.
  - Check operating pressure in the plant's supply network (max. 6 bar (87.02 PSI) system overpressure).
- Every six months:
- Check all electrical and mechanical connections for secure fit.



In case of soiled material or material with a high dust content, equipment should be checked regularly for smooth operation.

The indicated maintenance intervals are average values.

Check whether for your specific type of application, the maintenance intervals must be reduced.

## 6. Functional description

Version: 64.10-0251D01 08/02



This functional description is intended for the operating personnel of the equipment.

Prerequisite for this functional description is general knowledge of conveyor systems operation.

Ensure in each case that the operating personnel are sufficiently informed.



The unit may only be operated with mounted conveying lines.



The unit may only be operated in conjunction with a conveying unit / conveying system.

## 6.1. General information

The SKW-E has 2 input connecting branches (virgin material intake port, regrind intake port) and an output connecting branch leading to the conveyor unit.

With the SKW-E it is possible to convey two components to a hopper loader.

The SKW-E works in dependence on the conveying cycles of the conveyor unit. It is only in operation when material is conveyed.

The SKW-E is available in 2 versions:

- Version 1  
operation of SKW-E  
SKW-E for connection to a Sterling single conveyor unit (230 V or 24 V output) or to a conveyance control system.
- Version 2  
operation of conveyance control system  
SKW-E for connection to a conveyance control system.

## 6.2. Control

### 6.2.1. Version 1

The control unit is installed on the base plate of the SKW-E or in a maximum distance of 3 meters.

The conveying ratio as well as the switching cycles are set by means of the keys on the front side of the control system.

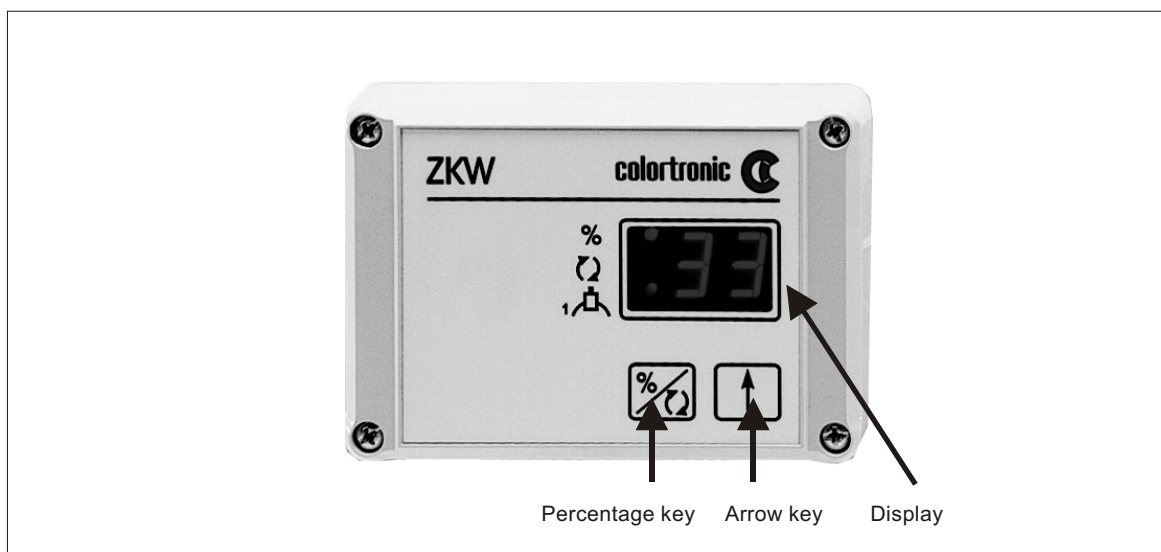

Control



### 6.2.1.1. Conveying ratio

The conveying ratio between component 1 (= regrind) and component 2 (= virgin material) can be freely selected.

The control setting refers to the conveying time of component 1 (= regrind).

The conveying time of component 1 can be set from 0 to 99 % of total conveying time.

#### Example

Proportioning valve setting: 22 %

Conveying ratio: 22 % component 1 and 78 % component 2



Conveying ratio relates to conveying time, not to the amount of material conveyed.

### 6.2.1.2. Switching cycles

During each switching cycle, the SKW-E switches back and forth one time. The pre-set conveying ratio is not affected by this. In order to prevent strong formation of layers in the conveyed material, the number of switching cycles per conveying procedure can be freely selected. Setting takes place by entry of one cycle period. The cycle period can be set between 5 and 50 seconds. The setting is carried out in five seconds.



The cycle period may not be longer than the conveying time.



The shorter the cycle period, the higher the number of switching cycles.

The higher the number of switching cycles, the less significant is the zoning effect in the hopper loader.

**Example:**

Conveying time: 90 seconds, cycle period = 15 seconds

Calculation of switching cycles:

$$\frac{\text{conveying time}}{\text{cycle period}} \quad \text{switching cycles} \quad \frac{90 \text{ s}}{15 \text{ s}} \quad 6 \text{ switching cycles}$$



Cycle period must always be high enough that both virgin material and re-grind are conveyed properly.

**6.2.2. Version 2 (optional)**

On the SKW-E housing, a terminal box is installed (optional: terminal box with 3 light-emitting diodes = LEDs for limit position monitoring).



The two green LEDs show the two end positions of the pneumatic push-piston. The red LED is illuminated in case of a disturbance.

The conveying ratio and the switching cycles are entered into the control system of the conveying control.

Observe the operating manual of the conveying control.

---

## 7. Transport, Assembly and Storage

Version: 64.10-0251GB01 08/02



This chapter is intended for all operating personnel of the equipment.

Personnel using these instructions must be instructed in the regulations for the prevention of accidents, the operating conditions and safety regulations and their implementation.

Ensure in each case that the operating personnel are sufficiently informed.

Please inform all persons within the range of action of the equipment of the direct and indirect hazards connected with the equipment.

Please observe all safety regulations for the operation of lifting equipment.

## 7.1. Transport and Packing



Please ensure adequate carrying capacity of the lifting equipment.

The equipment pass a rigorous operating test in the factory and are packed carefully to avoid transport damage.

Please check packing on delivery for transport damage.

The inlet and discharge flanges are sealed with plugs, so that no dirt can enter during transport. Plugs must be removed before assembly.

Packing materials should be disposed of according to environmental laws or reused.

Only use for transport of the equipment a suitable lifting device (e. g. a fork lift truck or a workshop crane).

For transport of control cabinets fasten the transport cables to the eyelets of the control cabinets

Transport must be shock-proofed and free from vibrations.

## 7.2. Assembly



Please ensure adequate carrying capacity of the lifting equipment.

Check the carrying capacity of the point of installation, particularly if installed on a platform.

The place selected for installation should be as free of vibrations as possible.

The main switch must be freely accessible.

Ground the equipment against electrostatic charging.

## 7.3. Storage

Between delivery and machine commissioning the equipment should be stored in a dry, dust-free and vibration-free room.

The control system may only be stored at temperatures from -25 to +55°C (-13 to +131 °F).

## 8. Installation instructions

Version: 64.10-0251GB01 08/02



These installation instructions are intended for persons with skills in electrical and mechanical areas due to their training, experience and received instructions.

Personnel using these installation instructions must be instructed in the regulations for the prevention of accidents, the operating conditions and safety regulations and their implementation.

Ensure in each case that the personnel are informed.

The installation instructions provided in the corresponding operating instructions apply for all connected equipment.

Observe safety regulations with regard to lifting gear handling

All installation work must be carried out with the equipment disconnected from electrical power and compressed air supply.



For installation work taking place at heights of over approx. 1829 mm (6 ft.), use only ladders or similar equipment and working platforms intended for this purpose. At greater heights, the proper equipment for protection against falling must be worn.

Use only suitable lifting gear which is in proper working order and load suspension devices with sufficient carrying capacity. Do not stand or work under suspended loads!

Use suitable workshop equipment.



Install the equipment such that all parts are easily accessible; this facilitates maintenance and repair work.

## 8.1. Installation

Installation is possible in any position.

The control system can be installed on the base plate or in a maximum distance of 3 m (9.84 ft.) from the unit. The control unit must be accessible at any time.

Install the SKW-E in such manner that differences in conveying distances for the two components are avoided.

Please note that the maximum ambient temperature near the SKW-E must not exceed +45°C (113°F).

Remove the plugs from the pipe bends.

Install the regrind line at intake port 1 (A).

Install the virgin material line at intake port 2 (B).

Install the feed line to the hopper loader at the outlet port (C).

Align both suction pipes nearly equally in order to avoid inaccurate percentage preselection results.

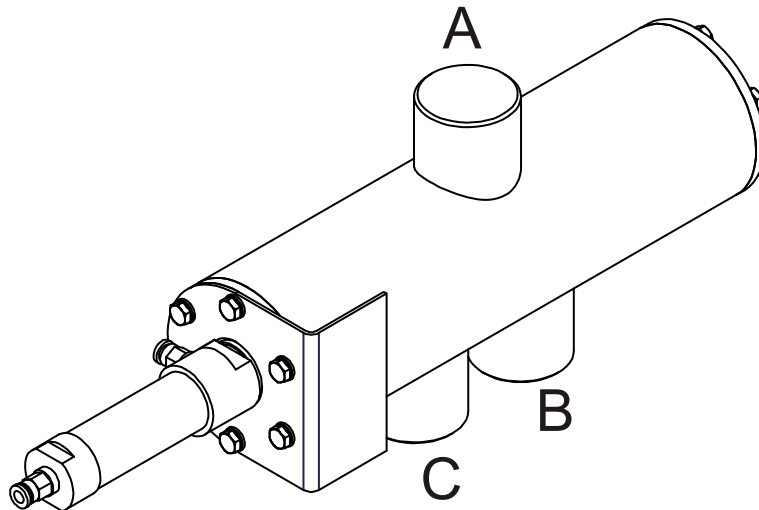

## 8.2. Electrical connection



The regulations of the local Electricity Board must be observed.

Before connection to the electricity supply, it should be ensured that the supply voltage and the power frequency are in accordance with the data on the name plate of the machine.

The electrical connection may only be carried out by Sterling service staff or trained personnel authorized by Sterling.

It is not permitted for other persons to undertake the electrical connection.

All work is to be carried out with the equipment disconnected from electric power and compressed air supply.

The main switch must be freely accessible.

Ground the equipment against electrostatic charging.

If the solenoid valve is tension free the push-piston is extended and the virgin material intake port opened.

### 8.2.1. Sterling Single Conveyor Unit with 110 V-Output Port

The power consumption amounts to approx. 15 watt.

The operating voltage amounts to approx. 110 V/60 Hz.  
Special voltages upon request.

Install the cable (2 x 0.75 mm<sup>2</sup>, 30 cm long) from the solenoid valve of the pneumatic cylinder in the control system (please follow the connection diagram).

Install the cable (3 x 0.75 mm<sup>2</sup>, 1.8 m long) from the control system of the SKW-E in the control system of the single conveyor unit (please follow the connection diagram).

Or, if it is not long enough, install and mount a cable (at least 3 x 1 mm<sup>2</sup>) from the single conveyor unit to the SKW-E (please follow the connection diagram).

Follow the operating manual of the single conveyor unit.

---

### 8.2.2. Sterling Single Conveyor Unit with 24 V-Output Port

The power consumption amounts to approx. 15 watt.

The operating voltage amounts to approx. 24 V.

Install the cable (2 x 0.75 mm<sup>2</sup>, 30 cm long) from the solenoid valve of the pneumatic cylinder in the control system (please follow the connection diagram).

Install the cable (3 x 0.75 mm<sup>2</sup>, 1.8 m long) from the control system of the SKW-E in the control system of the single conveyor unit (please follow the connection diagram).

Or, if it is not long enough, install and mount a cable (at least 3 x 1 mm<sup>2</sup>) from the single conveyor unit to the SKW-E (please follow the connection diagram).

Follow the operating manual of the single conveyor unit.

### 8.2.3. Connection to a conveyance control system



The electrical connection to a conveyance control system may only be made by skilled personnel authorized by Sterling.

Other persons are not permitted to install electrical connections.



### 8.3. Compressed air supply

For activating the pneumatic push-piston a compressed-air supply is necessary.

Check compressed air piping for correct installation and assembly.

Check fittings, length and quality of the hose connections for agreement with requirements.

The operating pressure is 5-6 bar (72.52-87.02 PSI) (system overpressure).

Check the compressed air supplied by the plant's supply network.

Adjust compressed air pressure to 5-6 bar (72.52-87.02 PSI) (system overpressure).

Connect the unit to the plant's supply network by means of a hose.



Depressurize compressed air supply lines which must be opened.



Compressed air must be dewatered, dustfree and oilfree.

Adjust pressure to a max. value of 6 bar (87.02 PSI) (system overpressure).

Install a maintenance unit (pressure reducer with water separator and oiler) if required.

## 9. Technical data

Version: 64.10-0251GB01 08/02



These instructions apply to all persons within the range of action of the equipment.

These operating instructions are to be used by all persons assigned activities connected with the equipment.

**Basic Version**

- Integrated, dustproofed controller with digital display
- Voltage 24 V DC / 230 V AC, N, PE
- Compressed air supply 4-6 bar system over pressure
- Connection to a conveying control system or a conveyor
- Regrind adjustable 0-100 %
- Weight 500 g (1.10 lbs.)

**Configurations**

- SKW-E without controller, for connection and use only in conjunction with a conveying control system
- SKW-E with integrated, dustproofed controller and digital display
- ZKW without controller, with integrated final switch position monitoring for connection and use only in conjunction with a conveying control system
- ZKW 40-E for connection to a 40 mm (1.6") pipe system
- ZKW 50-E for connection to a 50 mm (2") pipe system

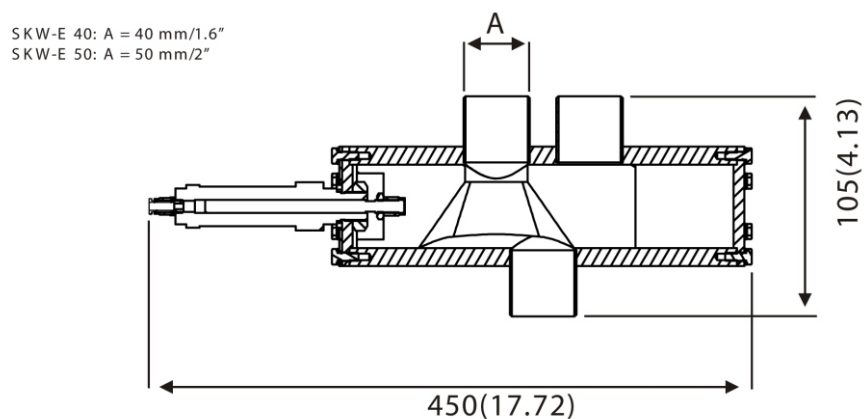
**Dimension Sheet**

Dimensions and data without obligation. Dimensions in mm.( in). Specifications may be subject to alterations.

---

## 10. Spare Parts List

Version: 64.10-0251GB01 08/02



This spare parts list is intended to be used only by trained personnel.  
Other persons are not permitted to modify or repair the equipment.



Wear Code:

A = Wearing part, fast used up

B = Wearing part

C = Spare part, storekeeping for 1 year

D = Spare part, storekeeping for 2 years

E = Spare part, storekeeping for more than 2 years

10.1. SKW-E

Pos.	Order no.	Designation
1	84082	4/2 Solenoid valve
	84080	Cable plug
	84081	Noise reducer
2	85502	Pneumatic thruster SKW-E 40
2	82981	Pneumatic thruster SKW-E 50
3	37736	Push-piston SKW-E 40 (POM)
3	37720	Push-piston SKW-E 50 (POM)
4	83401	Controller 24 V
4	83400	Controller 230 V, 50 Hz
	O/N	Controller 110V 60 Hz

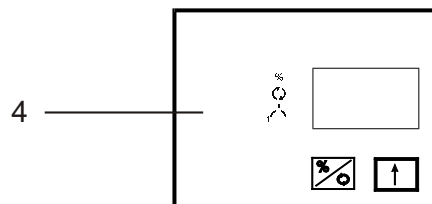
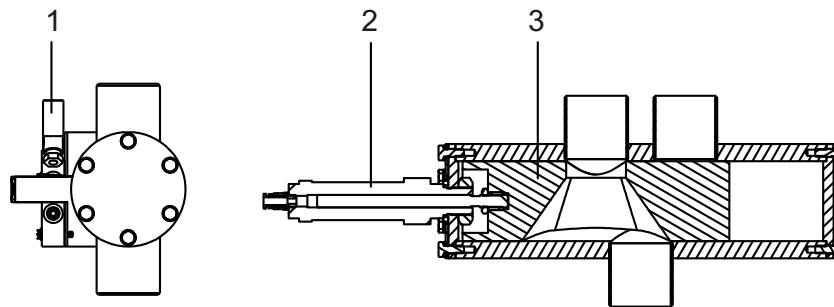

10.2. Accessories



Please observe the operating manuals in chapter 11.

## 11. Accessories

Version: 64.10-0251GB01 08/02

Table Conveying time / Number of switching cycles

-----

-----

Conveying time (sec.)	Number of switching cycles at cycle period (seconds)									
	50	45	40	35	30	25	20	15	10	5
5	*	*	*	*	*	*	*	*	*	1
10	*	*	*	*	*	*	*	*	1	2
15	*	*	*	*	*	*	*	1	1,5	3
20	*	*	*	*	*	*	1	1,3	2	4
25	*	*	*	*	*	1	1,3	1,7	2,5	5
30	*	*	*	*	1	1,2	1,5	2	3	6
35	*	*	*	1	1,2	1,4	1,8	2,3	3,5	7
40	*	*	1	1,1	1,3	1,6	2	2,7	4	8
45	*	1	1,1	1,3	1,5	1,8	2,3	3	4,5	9
50	1	1,1	1,3	1,4	1,7	2	2,5	3,3	5	10
55	1,1	1,2	1,4	1,6	1,8	2,2	2,8	3,7	5,5	11
60	1,2	1,3	1,5	1,7	2	2,4	3	4	6	12
65	1,3	1,4	1,6	1,9	2,2	2,6	3,3	4,3	6,5	13
70	1,4	1,5	1,8	2	2,3	2,8	3,5	4,7	7	14
75	1,5	1,7	1,9	2,1	2,5	3	3,8	5	7,5	15
80	1,6	1,8	2	2,3	2,7	3,2	4	5,3	8	16
85	1,7	1,9	2,1	2,4	2,8	3,4	4,3	5,7	8,5	17
90	1,8	2	2,3	2,6	3	3,6	4,5	6	9	18
95	1,9	2,1	2,4	2,7	3,2	3,8	4,8	6,3	9,5	19
100	2	2,2	2,5	2,9	3,3	4	5	6,7	10	20
105	2,1	2,3	2,6	3	3,5	4,2	5,3	7	10,5	21
110	2,2	2,4	2,8	3,1	3,7	4,4	5,5	7,3	11	22
115	2,3	2,6	2,9	3,3	3,8	4,6	5,8	7,7	11,5	23
120	2,4	2,7	3	3,4	4	4,8	6	8	12	24

\* = Setting not permitted

## 12. Electrical manual

Version: 64.10-0 251GB01 08/02



This electrical manual is intended to be used only by Sterling service personnel and trained personnel authorized by Sterling.

Other persons are not permitted to modify or repair the equipment.

- Connection diagram no.: \_\_\_\_\_
- Currently not available; will be delivered at a later date !



**SKW-E, 24 V**

**SKW-E, 110 V**