

# User Manual For Camera C6D

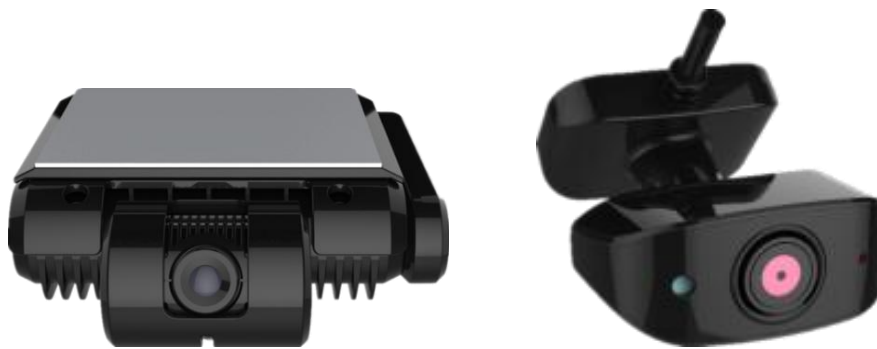

# 1. Product characteristics

## 1.1. Overview

Streamax C6D (3.0) is a kind of cost-effective device designed for mobile video surveillance. Its characteristics are as follows:

- Supports 3G / 4G, Bluetooth, WIFI, 6 axis and other functions, which is easy to install;
- It can record the vehicle track for further analysis;
- SD card video storage, maximum support 256GB, and it has anti-theft function;
- Patented file system to protect passengers' privacy;
- Industrial design requirements, aluminum alloy shell, a large area of heat teeth, good heat dissipation.
- Compact size, light weight. It can be pasted to the glass on the rear side of rearview mirror, which will not effect the driver driving.
- The internal 720P camera is with infrared, recording function, which can clearly capture the driver to protect the driver's safety;
- The external 1080P camera can clearly record the scene outside. When accidents happen, it could be used as evidence for police.

## 1.2. Specifications

<b>Network</b>	WIFI	Support,option
	Bluetooth	Support,option
	3G/4G	Support,option
<b>Location</b>	GPS	Support
<b>Sensor</b>	6-axis Sensor	Support
<b>Miles/Time Calculation</b>	Vehicle pulse acquisition	Support
<b>LED</b>	It shows the device working status The indicator light shows the four states of the device: Power: the device is powered, the red light is always bright; Normal operation: green light is always bright; Fault alarm: indicator red light flashes once a second; Sleep: green light flashes 1 second and off 10 seconds.	
<b>Storage</b>	SD Card	SDXC64G/128G/256G optional
	Main stream resolution and frame rate	Inside: 720P @ 30fps Outside: 1080P @ 30fps
	Max.	Main stream stream 1080P @ 30 frames + 720P @ 30 frames,
	Image setting	Brightness, Chroma, Contrast, saturation and sharpness
	Video coding	H.265/H.264
	Video compression bit rate	500Kbps ~ 6Mbps
	Audio compression standard	ADPCM

	General function	Heartbeat mechanism, multi-level user management
	Intelligent alarm	Not support
	CBR / VBR	Support
	Audio input	Support
	Built-in speaker	Built-in speakers for broadcasts, prompting drivers or passengers
<b>Camera parameters</b>	Sensor(inside vehicle)	1/3" 1.23M pixel CMOS Sensor
	Sensor(outside vehicle)	1/2.9" 2M pixel CMOS Sensor
	Electronic Shutter	1/30Second-1/100000 Second
	Lens	Inside:2.3mm Outside:4mm
	Lens port	M12
	Day/Night IR-Cut	Inside: support Outside: not support
	Wide Dynamic Range	Digital Wide Dynamic Range
	Black-light Compensation	Support
	S/N	≥48db
	IR distance	Inside: 3m Outside: not support
<b>Ports</b>	USB	Mini-B USB2.0
	IPC	1 channel
	SD card slot	1
	SIM card slot	1
	RS232	2 channel
	Alarm	2 channel
	SPEED	1 channel
	Sensor IN	2 channel
	Power output	5VDC@500mA , 12VDC@500mA
	Power supply	DC 9~36V
	Normal power consumption	6W
<b>Others</b>	Temperature	-30°C~+70°C
	Storage temperature	-40°C~+85°C
	Humidity	95%

### 1.3. Dimension (Unit: mm)

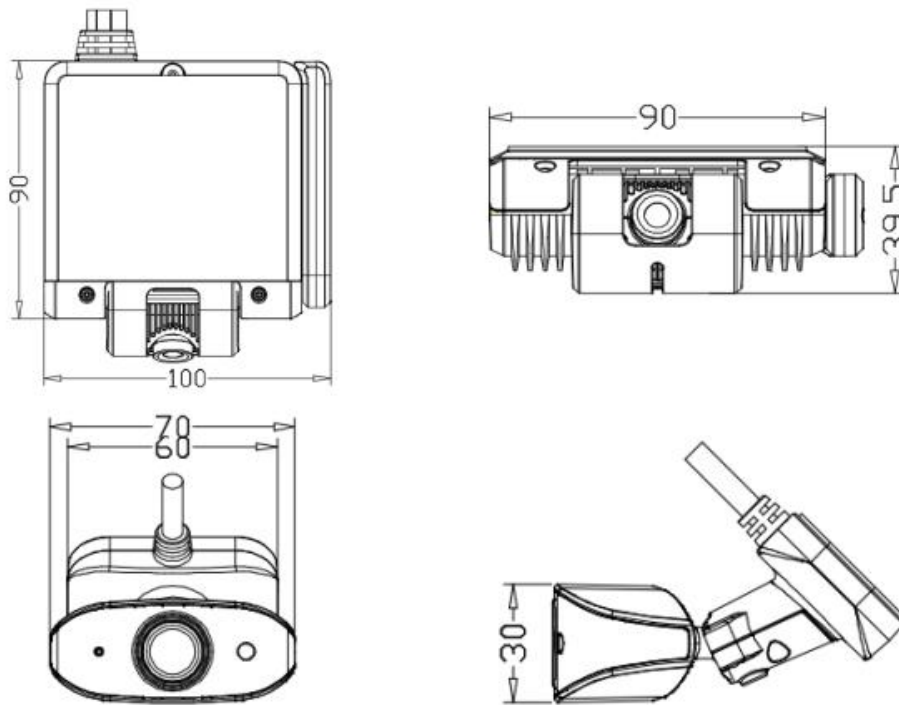

### 1.4. Definition

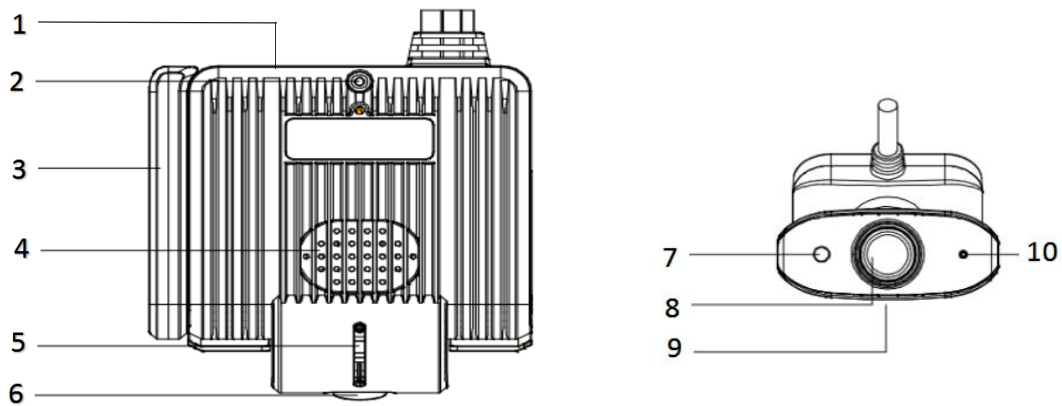

Items	Definition	Items	Definition
1	MIC	7	Photosensitive area
2	Fixing screw of cover	8	C26 lens ( towards inside )
3	Bluetooth & WIFI	9	Fixing screw of C26
4	Speaker	10	MIC
5	Fixing screw of C6D		
6	C6D lens ( towards outside )		

## 2. Product installation

### 2.1. Diagram

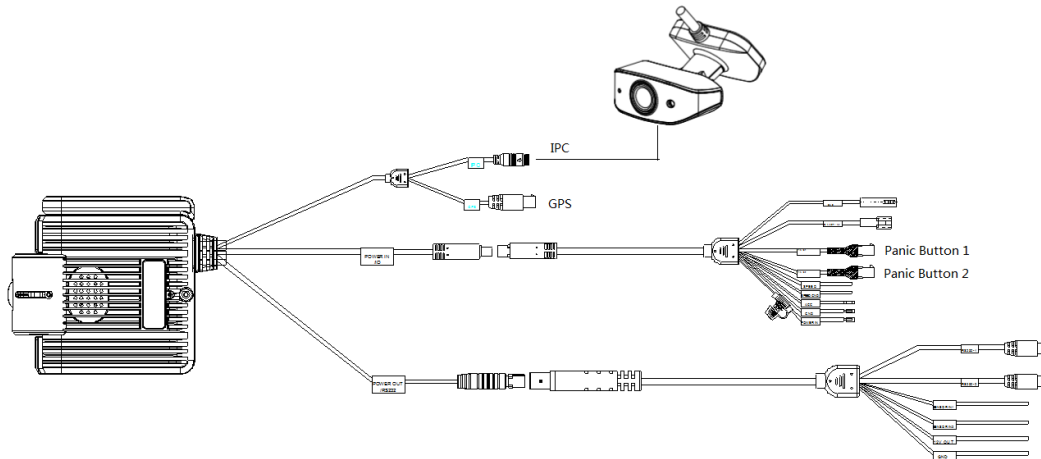

### 2.2. External cable interface definition

10P signal input line definition:

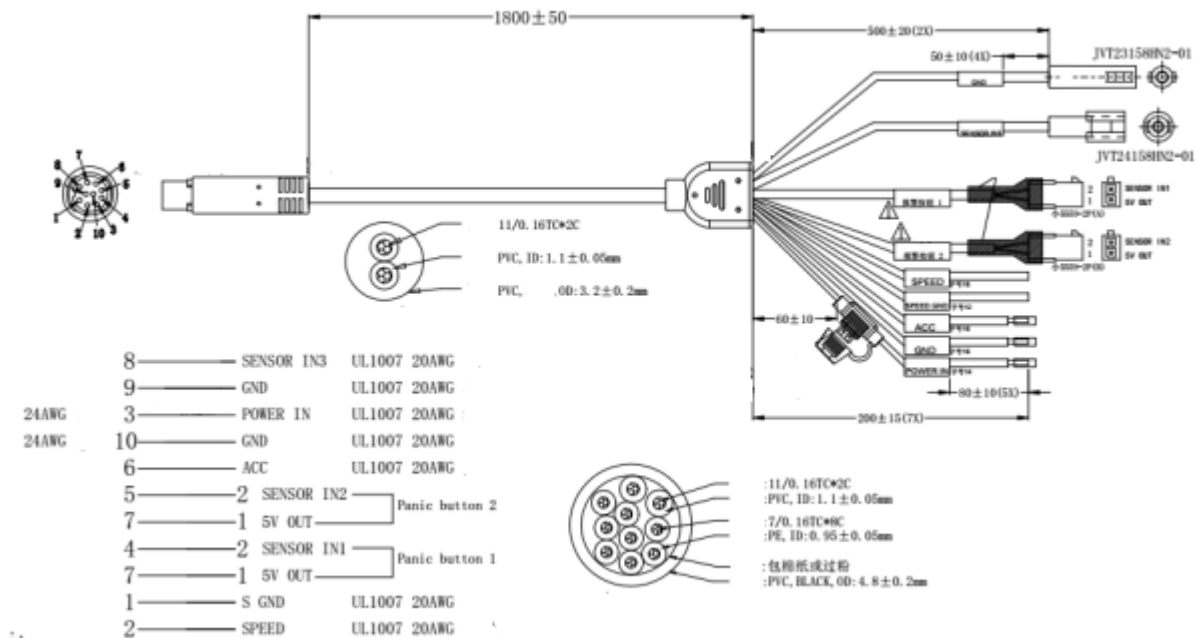

9PIN signal input line definition:(option)

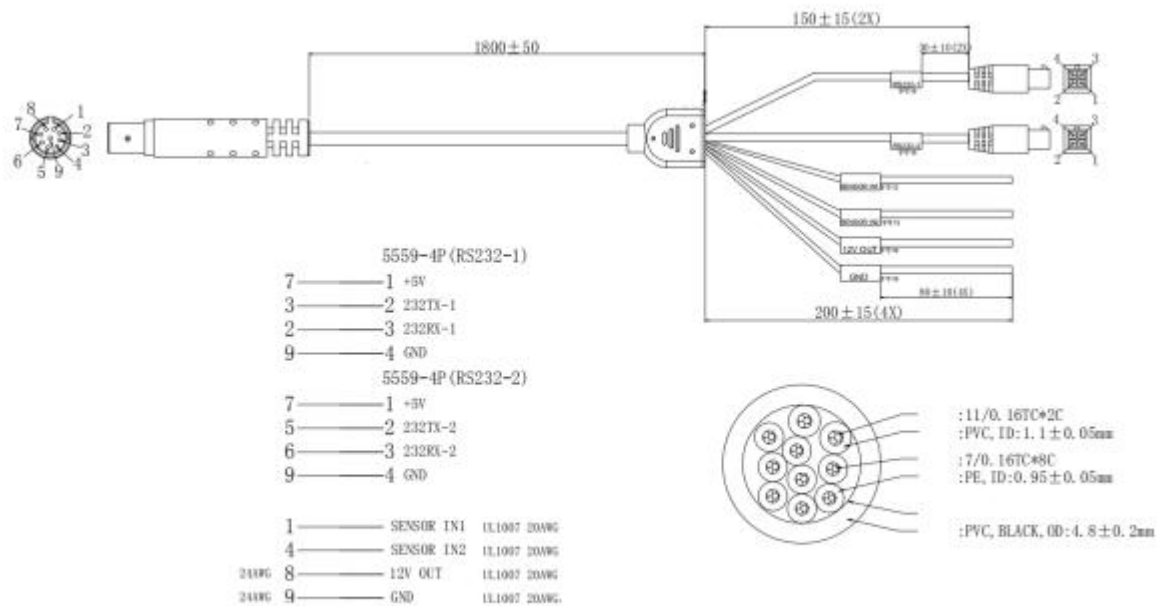

### 3. FAQ

#### 1) The system can't start?

- Check the input power, whether the power wire is connected correctly, whether the ground wire is connected back to the battery, and whether the fuse on the power wire is in good condition.
- Check whether the ACC signal wire input to the power is with voltage higher than 7 V.

#### 2) The device restarts uninterruptedly?

- Check whether the voltage of MDVR is insufficient. If the voltage is less than the start-up voltage of the device, the device would always restart.
- The problem in hard disk/SD card may cause the failure to start. Take off the storage part and check whether it is broken down.

#### 3) The device can't record?

- Check whether the storage disk is installed, whether it is in good contact, and whether the disk can be read normally in computer.
- Check whether the storage disk is formatted. The storage disk should be formatted before normally storing record files.
- Check whether there is video signal input into the device from camera, and whether there is video/image on the screen.

#### 4) There is no voice in record file?

- Check whether there is an external pickup, or whether the camera features with the

- function of audio collection.
- b. Access to Video Channel Settings, check if Audio is set on.
  - c. There must be video input into the channel for recording and it must record normally.

#### **5) The GPS works abnormally?**

- a. Check whether the GPS antenna is installed correctly. There is a silk print logo on the GPS antenna holder behind the host device.
- b. Check whether the antenna receiver is sheltered. It should not be covered by any stuff, which may cause it not to receive signals.
- c. Environmental influence such as tree shades, being inside tunnel, driving near tall building or elevated roads, thunderstorms or other weather influence, etc. can also cause signal loss or receiving wrong signals.

#### **6) The device can't shut down in ignition switch mode?**

- a. Check if the ACC line connection mode is correct; and check whether there is voltage on ACC yellow line when the key is turned off.
- b. If the device has been set with schedule recording, it can't shut down if it is still during recording time of the task table.

## **4. WARNING**

**This device complies with part 15 of the FCC Rules. Operation is subject to the following two conditions:**

- (1) This device may not cause harmful interference
- (2) this device must accept

## **FCC statement**

This device complies with Part 15 of the FCC Rules: Operation is subject to the following two conditions:

1. This device may not cause harmful interference and
2. This device must accept any interference that is received, including any interference that may cause undesired operation.

### **\*RF exposure warning statements**

This equipment complies with FCC radiation exposure limits set forth for an uncontrolled environment. This equipment shall be installed and operated with minimum distance 20cm between the radiator & body.

**NOTE:** This equipment has been tested and found to comply with the limits for a Class B digital device, pursuant to part 15 of the FCC Rules. These limits are designed to provide reasonable protection against harmful interference in a residential installation. This equipment generates uses and can radiate radio frequency energy and, if not installed and used in accordance with the instructions, may cause harmful interference to radio communications. However, there is no guarantee that interference will not occur in a particular installation. If this equipment does cause harmful interference to radio or television reception, which can be determined by turning the equipment off and on, the user is encouraged to try to correct the interference by one or more of the following measures:

- Reorient or relocate the receiving antenna.
- Increase the separation between the equipment and receiver.
- Connect the equipment into an outlet on a circuit different from that to which the receiver is connected.
- Consult the dealer or an experienced radio/TV technician for help

Changes or modifications to this unit not expressly approved by the party responsible for compliance could void the user's authority to operate the equipment.