

Power-PRO™ XT

REF Model 6506

stryker®

Operations/Maintenance Manual



For parts or technical assistance:
USA: 1-800-327-0770

CE

Table of Contents

Symbols and Definitions	6
Symbols	6
Warning/Caution/Note Definition	7
Introduction	8
Product Description	8
Intended Use of Product.	8
Specifications	9
Contact Information	11
Serial Number Location	11
Product Illustration	12
Summary of Safety Precautions	13
Pinch Points	18
Setup Procedures.	19
Setting Cot Load Height and “Jog” Function	20
Product Inspection	21
Cot Fastener Installation	23
Installing the In-Fastener Shut-Off	25
Vehicle Safety Hook Selection	26
Vehicle Safety Hook Installation	27
Vehicle Configuration	27
Required Hardware for Installation of the Safety Hook (Not Supplied)	27
Front to Back Positioning of the Safety Hook	28
Side to Side Positioning of the Safety Hook	29
Installing the Safety Hook.	29
Operation Guide	30
Operating Guidelines	30
Proper Lifting Techniques.	30
Transferring the Patient to the Cot	31
Rolling the Cot.	31
Adjusting The Height of the Cot with Two Operators	32
Loading the Cot into a Vehicle with Two Operators - Powered Method.	33
Loading the Cot into a Vehicle with Two Operators at the Foot End - Powered Method.	34
High Speed Retract/Extend	34
Loading an Empty Cot into a Vehicle with One Operator - Powered Method.	35
Unloading the Cot from a Vehicle with Two Operators - Powered Method	36
Unloading an Empty Cot from a Vehicle with One Operator - Powered Method	37
Using the Manual Override.	38
Loading the Cot into a Vehicle with Two Operators - Manual Method.	39
Unloading the Cot from a Vehicle with Two Operators - Manual Method	40
Unloading an Empty Cot from a Vehicle with One Operator - Manual Method	41
Using Additional Assistance	42
Removing and Replacing a SMRT Pak	43
Using the Battery Power Indicator.	44
Using the Hour Meter.	45

Table of Contents









Using Restraint Straps	46
Using the Optional Restraint Belt Extension	48
Operating the Siderails.	49
Operating the Backrest	49
Operating the Retractable Head Section	50
Adjusting the Footrest	51
Raising and Lowering the Optional Gatch	52
Operating the Optional Wheel Lock(s)	53
Operating the Optional 2-Stage I.V. Pole	54
Operating the Optional 3-Stage I.V. Pole	55
Optional Accessories	56
Using the Equipment Hook	57
Using the Retractable Head Section Oxygen Bottle Holder	58
Using the Kickstand for Dialysis Scale	59
Attaching the Pedi-Mate® Infant Restraint System	60
Using the Transfer Flat.	62
Installing the Backrest Storage Pouch.	62
Installing the Head End Storage Flat.	63
Installing the Base Storage Net	64
Cleaning.	65
Washing Procedure	65
Washing Limitations	65
Removal of Iodine Compounds	66
Preventative Maintenance.	67
Lubrication.	67
Regular Inspection and Adjustments	68
Maintenance Record.	71
Training Record	72
Troubleshooting Guide	73
Electronics and Hydraulics Locator.	73
Hydraulic Manifold Components Locator	74
Electrical System Block Diagram	75
Troubleshooting Guide	77
Main Cable Assembly	80
Electronics Assembly.	80
Electronics Assembly Wiring Schematics	81
Quick Reference Replacement Parts List	82
Service Information.	85
Manual Release Cable Adjustment	85
Filling the Reservoir	85
Wheel Locking Force Adjustment	86
Cot Retaining Post Adjustment	86

Table of Contents

EMC Information	87
Warranty	91
Stryker EMS Return Policy	92
Return Authorization	92
Damaged Merchandise	92
International Warranty Clause	92
Patent Information	92

Symbols and Definitions

SYMBOLS

	Warning, consult accompanying documentation
	Safe Working Load Symbol
	Dangerous Voltage Symbol
	Pinch Point
	Extend
	Retract
	Type B Equipment: equipment providing a particular degree of protection against electric shock, particularly regarding allowable leakage current and reliability of the protective earth connection. Internally Powered Equipment: Equipment able to operate from an internal (removable) electric power source. Mode of Operation: 16.7% (1 Min. On / 5 Min. Off)
IPX6	Protection from powerful jets of water
	Medical Equipment Classified by Underwriters Laboratories Inc. With Respect to Electric Shock, Fire, and Mechanical Hazards Only in Accordance with UL 60601-1, and CAN/CSA C22.2 No. 601.1.
	In accordance with European Directive 2002/96/EC on Waste Electrical and Electronic Equipment, this symbol indicates that the product must not be disposed of as unsorted municipal waste, but should be collected separately. Refer to your local distributor for return and/or collection systems available in your country.

Symbols and Definitions

WARNING/CAUTION/NOTE DEFINITION

The words **WARNING**, **CAUTION** and **NOTE** carry special meanings and should be carefully reviewed.

WARNING

Alerts the reader about a situation, which if not avoided, could result in death or serious injury. It may also describe potential serious adverse reactions and safety hazards.

CAUTION

Alerts the reader of a potentially hazardous situation, which if not avoided, may result in minor or moderate injury to the user or patient or damage to the equipment or other property. This includes special care necessary for the safe and effective use of the device and the care necessary to avoid damage to a device that may occur as a result of use or misuse.

NOTE

This provides special information to make maintenance easier or important instructions clearer.

Introduction

This manual is designed to assist you with the operation and maintenance of the Power-PRO™ XT Cot. Carefully read this manual thoroughly before using the equipment or beginning maintenance on it. To ensure safe operation of this equipment, it is recommended that methods and procedures be established for educating and training staff on the safe operation of this cot.

PRODUCT DESCRIPTION

The Model 6506 Power-PRO™ XT powered cot reduces manual lifting. The battery-powered hydraulic system raises and lowers the patient with the touch of a button and the retractable head section shortens the cot for 360-degree mobility in any height position.

INTENDED USE OF PRODUCT

The Model 6506 Power-PRO™ XT is a battery powered hydraulic lift wheeled stretcher that consists of a platform mounted on a wheeled frame that is designed to support patients in a horizontal position for transport or administration of medical care. The device has side rails, supports for fluid infusion equipment, and patient restraint straps. The frame is collapsible for use in an ambulance.

Introduction

SPECIFICATIONS

	Safe Working Load Note: Safe Working Load indicates the sum of the patient, mattress and accessory weight.	700 pounds	318 kg
Maximum Unassisted Lift Capacity		500 pounds	225 kg
Backrest Articulation/Shock Position		0° to 73° / +15°	
Overall Length/Minimum Length/Width		81" / 63" / 23"	206 cm / 160 cm / 58 cm
Height ¹		Adjustable from 14" to 41.5"	Adjustable from 36 cm to 105 cm
Weight ²		125 pounds	57 kg
Caster Diameter/Width		6" / 2"	15 cm / 5 cm
Minimum Operators Required for Loading/ Unloading an Occupied Cot		2	
Minimum Operators Required for Loading/ Unloading an Unoccupied Cot		1	
Recommended Fastener Systems		Model 6370 or 6377 Floor Mount Type Model 6371 Wall Mount Type	
Recommended Loading Height ³		Up to 36"	Up to 91 cm
Roll-In Style		Yes	
Single Wheel Lock / Double Wheel Lock		Optional	
Hydraulic Oil		Stryker Part Number 6500-001-293	
Power System ⁴		- Battery 24V DC NiCd - SMRT™ Power System - Charger 120V/240Vac or 12V DC - SMRT™ Power System	
Standards (Cots and Chargers)		IEC 60601-1 CAN/CSA-C22.2 No. 601.1-M90 UL 60601-1 IEC 60601-1-2:2001 KKK-A-1822	

¹ Height measured from bottom of mattress at seat section to ground level.

² Cot is weighed with 1 battery and without mattress and restraints.

³ Cot may be set to any ambulance deck height ranging from 26" to 36" (66 cm to 91 cm).

⁴ Cot is compatible with the SMRT™ Power System.

Stryker reserves the right to change specifications without notice.

The Power-PRO™ XT is designed to conform to the Federal Specification for the Star-of-Life Ambulance (KKK-A-1822).

The Power-PRO™ XT is designed to be compatible with competitive cot fastener systems.

Patents pending.

The yellow and black color scheme is a proprietary trademark of Stryker Corporation.



CAUTION

- Changes or modifications to the unit not expressly approved by Stryker could void the user's authority to operate the unit.
- This equipment has been tested and found to comply with the limits for a Class A digital device, pursuant to part 15 of the FCC Rules. These limits are designed to provide reasonable protection against harmful interference when the equipment is operated in a commercial environment. This equipment generates, uses, and can radiate radio frequency energy and, if not installed and used in accordance with the instruction manual, may cause harmful interference to radio communications. Operation of this equipment in a residential area is likely to cause harmful interference in which case the user will be required to correct the interference at their expense.

[Return To Table of Contents](#)

Introduction

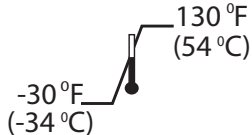
SPECIFICATIONS (CONTINUED)

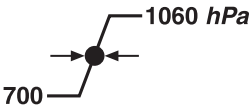
Environmental Conditions	Operation
Temperature	 A diagram showing a temperature range from -30°F (-34°C) to 130°F (54°C). The range is represented by a line with a vertical segment at the top and a vertical segment at the bottom, connected by a diagonal line. The top value is 130°F (54°C) and the bottom value is -30°F (-34°C).
Relative Humidity	 A diagram showing a relative humidity range from 0% to 100%. The range is represented by a line with a vertical segment at the top and a vertical segment at the bottom, connected by a diagonal line. The top value is 100% and the bottom value is 0%. There are three water droplets falling from the top of the vertical segment.
Atmospheric Pressure	 A diagram showing an atmospheric pressure range from 700 to 1060 hPa. The range is represented by a line with a vertical segment at the top and a vertical segment at the bottom, connected by a diagonal line. The top value is 1060 hPa and the bottom value is 700. There are two horizontal arrows pointing towards each other, meeting at a central point on the diagonal line.

Introduction

CONTACT INFORMATION

Contact Stryker Customer Service or Technical Support at: (800) 327-0770 or (269) 324-6500.

Stryker Medical
3800 E. Centre Avenue
Portage, MI 49002
USA

Please have the serial number (A) of your Stryker product available (as shown in Figure 1) when calling Stryker Customer Service or Technical Support. Include the serial number in all written communication.

SERIAL NUMBER LOCATION

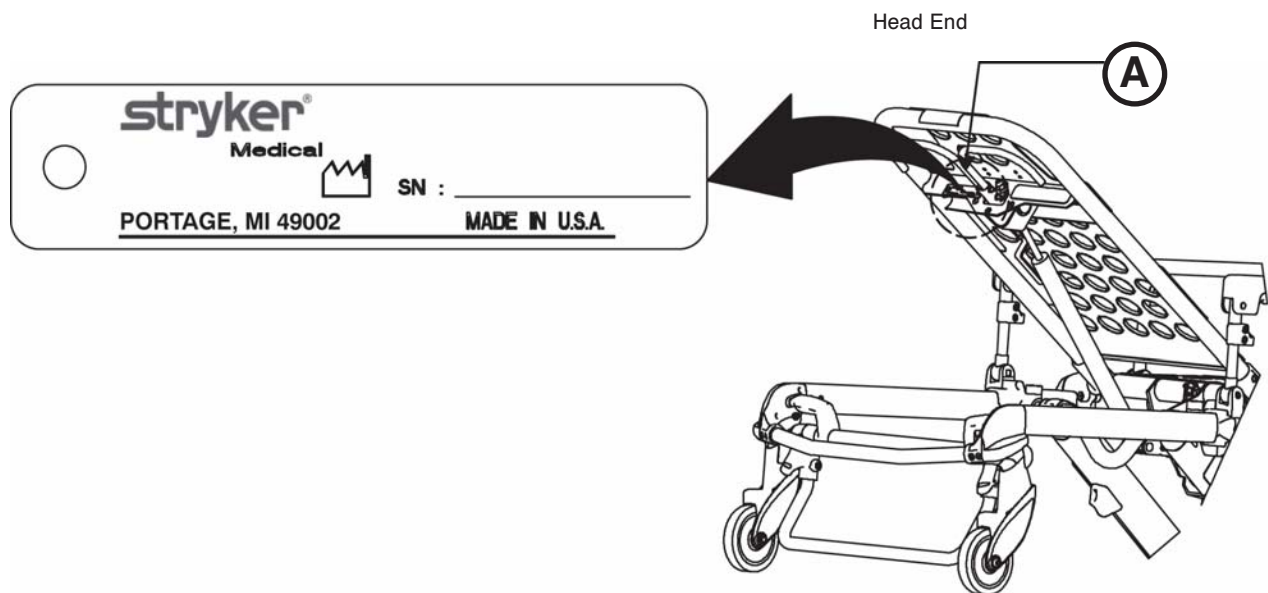

Figure 1: Cot Serial Number & Location

Introduction

PRODUCT ILLUSTRATION

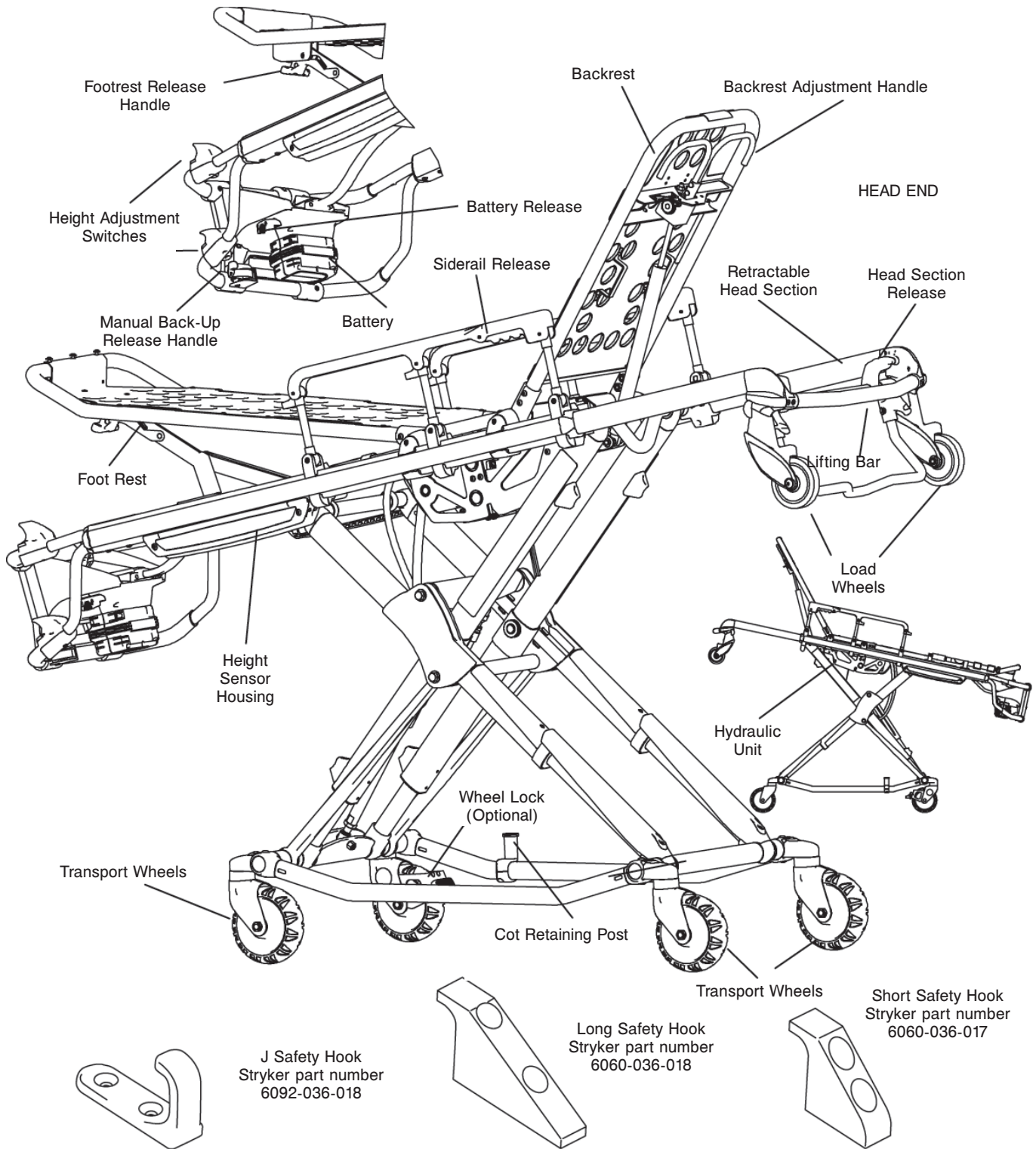

Figure 2: Cot Components

Summary of Safety Precautions

Carefully read and strictly follow the warnings and cautions listed on these pages. Service only by qualified personnel.

WARNING

- Improper usage of the cot can cause injury to the patient or operator. Operate the cot only as described in this manual.
- Do not modify the cot or any components of the cot. Modifying the product can cause unpredictable operation resulting in injury to the patient or operator. Modifying the product also voids its warranty (see [page 91](#)).
- Any emergency vehicle to be used with this cot **must** have the in-fastener shut-off system installed (see [page 25](#)).
- It is the responsibility of the cot operator to ensure that the cot being used in the Stryker Cot Fastener Systems meets the installation specifications listed on [page 24](#). Injury may result if a non-compatible cot is used in the Stryker Fastener System.
- The in-fastener shut-off must be positioned properly before placing the cot into service. Failure to install the in-fastener shut-off may cause injury to the patient or operator and/or damage to the vehicle.
- Do not attempt to operate the cot when it is loaded into a cot fastener.
- The in-fastener shut-off is **only** a means for disabling the electronic functionality. Damage to the product and/or injury to the patient and/or operator may occur if used for any other purpose.
- Have the vehicle safety hook installed by a certified mechanic. Improper safety hook installation can cause injury to the patient or operator and/or damage to the cot.
- Failure to install the safety hook can cause injury to the patient or operator. Install and use the safety hook as described on [page 27](#).
- The face of the safety hook that engages the safety bar should be located at least 3-3/4" from the leading edge of the door sill. After installation, verify that the cot legs lock into the load position without contacting the vehicle bumper.
- To avoid injury, verify that the safety bar has engaged the safety hook before removing the cot from the patient compartment.
- Verify that the safety hook always engages the cot safety bar regardless of how the cot is unloaded from the vehicle or injury to the patient or operator and/or damage to the cot may occur.
- The cot must have at least 5/8" of clearance between the vehicle bumper and the cot to disengage the safety bar when unloading the cot from the vehicle. Verify that the cot legs lock into the load position before disengaging the safety bar from the safety hook. Failure to properly lock the cot into position can cause injury to the patient or operator and/or damage to the cot.
- Entanglement in powered cot mechanisms can cause serious injury. Operate the cot only when all persons are clear of the mechanisms.
- Practice changing height positions and loading the cot until operation of the product is fully understood. Improper use can cause injury.
- Do not allow untrained assistants to assist in the operation of the cot. Untrained technicians/assistants can cause injury to the patient or themselves.
- Ensure proper hand placement on hand grips. Hands should be clear of red safety bar pivots while loading and unloading the cot or whenever changing height position of the cot with two or more operators.
- Do not ride on the base of the cot. Damage to the product could occur, resulting in injury to the patient or operator.
- Transporting the cot sideways can cause the cot to tip, resulting in possible damage to the product and/or injury to the patient or operator. Transporting the cot in a lowered position, head or foot end first, minimizes the potential of a cot tip.
- Grasping the cot improperly can cause injury. Keep hands, fingers and feet away from moving parts. To avoid injury, use extreme caution when placing your hands and feet near the base tubes while raising and lowering the cot.
- Always use all restraint straps to secure the patient on the cot. An unrestrained patient may fall from the cot and be injured.
- Never leave a patient unattended on the cot or injury could result. Hold the cot securely while a patient is on the product.
- Never apply the optional wheel lock(s) while a patient is on the cot. Tipping could occur if the cot is moved while the wheel lock is applied, resulting in injury to the patient or operator and/or damage to the cot.
- Siderails are not intended to serve as a patient restraint device. See [page 46](#) for proper restraint strap usage. Failure to utilize the siderails properly could result in patient injury.

[Return To Table of Contents](#)

Summary of Safety Precautions

WARNING (CONTINUED)

- Hydraulically raising or lowering the cot may temporarily affect electronic patient monitoring equipment. For best results, patient monitoring should be conducted when the cot is idle.
- High obstacles such as curbing, steps or rough terrain can cause the cot to tip, possibly causing injury to the patient or operator.
- If the cot is equipped with the optional kickstand, make sure that the kickstand remains in the retracted position and does not engage during transport.
- Transporting the cot in lower positions reduces the potential of a cot tip. If possible, obtain additional assistance or take an alternate route.
- Two operators must be present when the cot is occupied.
- Operators must be able to lift the total weight of the patient, cot and any items on the cot.
- The higher an operator must lift the cot, the more difficult it becomes to hold the weight. An operator may need help loading the cot if he/she is too short or if the patient is too heavy to lift safely. The operator must be able to lift the cot high enough for the cot legs to unfold completely and lock when the cot is unloaded. A shorter operator needs to raise their arms higher to enable the undercarriage to unfold.
- There must be a safety hook properly installed in the vehicle so that the bumper does not interfere with the front legs of the base frame.
- When using a standard cot fastener, do not load the cot into the vehicle with the head section retracted. Loading the cot with the head section retracted may cause the product to tip or not engage properly in the cot fastener, possibly causing injury to the patient or operator and/or damage to the cot.
- Whenever the weight of the cot and patient is off of the wheels, the cot will **automatically** enter the high speed retract mode if the retract (-) button is pressed.
- Once the weight is off of the ground, the operator(s) must support the load of the patient, cot and any accessories. Failure to support the load properly may cause injury to the patient or operator.
- The one person loading and unloading procedures are for use only with an empty cot. Do not use the procedures when loading/unloading a patient. Injury to the patient or operator could result.
- Do not pull or lift on the safety bar when unloading the cot. Damage to the safety bar could result and injury to the patient or operator could occur.
- Do not press the extend (+) button until the safety bar has engaged the safety hook.
- To avoid risk of electric shock, never attempt to open the battery pack for any reason. If the battery pack case is cracked or damaged, do not insert it into the charger. Return damaged battery packs to a service center for recycling.
- Do not remove the battery when the cot is activated.
- Avoid direct contact with a wet battery or battery enclosure. Contact may cause injury to the patient or operator.
- Do not attach restraints to the base or cross tubes, improper restraint attachment could result in damage to the cot further resulting in injury to the patient or operator.
- Siderails are not intended to serve as a patient restraint device. See [page 46](#) for proper restraint strap usage. Failure to utilize the siderails properly could result in patient injury.
- To avoid injury, always verify that the head section is locked into place prior to operating the cot.
- Never install or use a wheel lock on a cot with excessively worn wheels. Installing or using a wheel lock on a wheel with less than a 6" diameter could compromise the holding ability of the wheel lock, possibly resulting in injury to the patient or operator and/or damage to the cot or other equipment.
- If the cot is equipped with the optional retractable head section oxygen bottle holder, use caution while the oxygen bottle holder is installed to avoid pinching your fingers between the fowler bracket and the oxygen bottle.
- Stryker recommends that a two person operation is used when using the kickstand.
- Make sure that the patient weight is centered on the cot before using the kickstand.
- Engage the kickstand with your foot only.
- Lower cot height prior to engaging kickstand for increased stability.
- Make sure that the kickstand remains in the retracted position and does not engage during transport.
- Do not use the kickstand as a brake.
- Do not engage kickstand on a sloped surface.
- To avoid accidental release of the Pedi-Mate®, and possible injury to the infant, ensure that the restraint buckle is located away from obstructions on the cot or accessories.

Summary of Safety Precautions

WARNING (CONTINUED)

- When the optional head end storage flat is being used, ensure that it does not interfere with the operation of the retractable head section, safety bar and safety hook. Injury to the patient or operator could result. Use any appropriate personal safety equipment (goggles, respirator, etc.) to avoid the risk of inhaling contagion. Use of power washing equipment can aerate contamination collected during the use of the cot.
 - **SOME CLEANING PRODUCTS ARE CORROSIVE IN NATURE AND MAY CAUSE DAMAGE TO THE PRODUCT IF USED IMPROPERLY.** If the products described above are used to clean Stryker EMS equipment, measures must be taken to insure the cots are wiped with clean water and thoroughly dried following cleaning. Failure to properly rinse and dry the cots will leave a corrosive residue on the surface of the cots, possibly causing premature corrosion of critical components.
 - Failure to properly clean or dispose of contaminated mattress or other cot components will increase the risk of bloodborne pathogens and may cause injury to the patient or operator.
 - Escaping fluid under pressure can penetrate the skin causing serious injury. Avoid the hazard by relieving pressure before disconnecting hydraulic or other lines. Tighten all connections before applying pressure. If an accident occurs, see a doctor immediately. Any fluid injected into the skin must be surgically removed within a few hours or gangrene may result. Doctors unfamiliar with this type of injury should reference a knowledgeable medical source.
 - To avoid the risk of injury, do not use bare hands to check for hydraulic leaks.
-

CAUTION

- Changes or modifications to the unit not expressly approved by Stryker could void the user's authority to operate the unit.
 - This equipment has been tested and found to comply with the limits for a Class A digital device, pursuant to part 15 of the FCC Rules. These limits are designed to provide reasonable protection against harmful interference when the equipment is operated in a commercial environment. This equipment generates, uses, and can radiate radio frequency energy and, if not installed and used in accordance with the instruction manual, may cause harmful interference to radio communications. Operation of this equipment in a residential area is likely to cause harmful interference in which case the user will be required to correct the interference at their expense.
 - The cot can be set at any cot load height position. Establish the required cot load height before placing the cot into service.
 - When charging a battery in an ambulance, locate the charger in an enclosed cabinet and out of patient reach during transport.
 - Set the cot load height to the proper stop height prior to operation.
 - Installation of the safety hook should be done by a certified mechanic familiar with ambulance vehicle construction. Consult the vehicle manufacturer before installing the safety hook and be sure that the installation of the safety hook does not damage or interfere with the brake lines, oxygen lines, fuel lines, fuel tank or electrical wiring of the vehicle.
 - Before operating the cot, clear any obstacles that may interfere and cause injury to the operator or patient.
 - Do not "jog" the cot past the established cot load height of the product when the safety bar engages the vehicle safety hook or damage may occur to the product.
 - When unloading the cot from the patient compartment, ensure that the caster wheels are safely set on the ground or damage to the product may occur.
 - Do not "jog" the cot past the load height while the safety bar is engaged.
 - Remove the battery if the cot is not going to be used for an extended period of time (more than 24 hours).
 - Only use the battery and charger as specified.
 - The cot is not for use with an AC adapter.
 - Ensure that the battery is fully charged prior to placing into service. An uncharged or depleted battery may cause poor cot performance.
 - Ensure that the restraints are not entangled in the base frame when raising and lowering the cot.
 - Wheel lock(s) are only intended to help prevent the cot from rolling while unattended and to aid in patient transfer. A wheel lock may not provide sufficient resistance on all surfaces or under loads.
 - To avoid damage to the I.V. pole, the weight of the I.V. bags or equipment must not exceed 40 pounds (18 kg).
-

[Return To Table of Contents](#)

Summary of Safety Precautions

CAUTION (CONTINUED)

- To avoid damage to the equipment hook, the weight of the accessories or equipment must not exceed 35 pounds (15.9 kg).
 - To avoid damage to the retractable head section oxygen bottle holder (if equipped), the weight of the equipment must not exceed 40 pounds (18 kg).
 - Do not use two head end oxygen bottle holders at the same time.
 - Do not store items under the cot mattress. Storing items under the mattress can interfere with the operation of the cot.
 - The weight of the equipment in the pocketed backrest storage pouch (if equipped) must not exceed 20 pounds (9 kg).
 - The weight of the equipment in the base storage net (if equipped) must not exceed 20 pounds (9 kg).
 - Be careful when retracting the base to avoid damaging items stored in the base storage net.
 - The weight of the equipment in the head end storage flat (if equipped) must not exceed 40 pounds (18 kg).
 - DO NOT STEAM CLEAN OR ULTRASONICALLY CLEAN THE UNIT.
 - Maximum water temperature should not exceed 180°F/82°C.
 - Maximum air dry temperature (cart washers) should not exceed 240°F/115°C.
 - Maximum water pressure should not exceed 1500 psi/130.5 bar. If a hand held wand is being used to wash the unit, the pressure nozzle must be kept a minimum of 24 inches (61 cm) from the unit.
 - Towel dry all casters and interface points.
 - Failure to comply with these instructions may invalidate any/all warranties.
 - Always remove the battery before washing the cot.
 - A preventative maintenance program should be established for all Stryker EMS equipment. Preventative maintenance may need to be performed more frequently based on the usage level of the product. Close attention should be given to safety features including, but not limited to:
 - Hydraulic power mechanism
 - All electrical controls return to off or neutral position when released.
- For additional maintenance information, see the preventative maintenance information.
- Improper maintenance can cause injury or damage to the product. Maintain the cot as described in this manual. Use only Stryker approved parts and maintenance procedures. Using unapproved parts and procedures could cause unpredictable operation and/or injury and will void the product warranty (see [page 91](#)).
 - Failure to use authorized parts, lubricants, etc. could cause damage to the cot and will void the warranty of the product.
 - Hydraulic lines, hoses, and connections can fail or loosen due to physical damage, kinks, age, and exposure. Check hoses and lines regularly to avoid damage to the cot. Check and tighten loose connections.
 - Do not tip the cot onto its load wheels and actuate the product as this will allow air to enter the hydraulic system.
 - Do not lubricate the bearings in the X-frame as it will degrade the performance of the cot and may void its warranty (see [page 91](#)).
 - The cot retaining post comes preconfigured for an X-frame cot, if the fastener has been configured for an H-frame style cot, the cot retaining post must be adjusted to accommodate the fastener.
-

Summary of Safety Precautions

NOTE

- Loose items or debris on the patient compartment floor can interfere with the operation of the safety hook and cot fastener. Keep the patient compartment floor clear.
- This manual should be considered a permanent part of the cot and should remain with the product even if the cot is subsequently sold.
- Stryker continually seeks advancements in product design and quality. Therefore, while this manual contains the most current product information available at the time of printing, there may be minor discrepancies between your cot and this manual. If you have any questions, please contact Stryker Customer Service or Technical Support at (800) 327-0770 or (269) 324-6500.
- Adjustment of the rail clamp assembly may be required in order to compensate for any variation in the cot retaining post position depending on the cot manufacturer and model number.
- When replacing an existing safety hook with a new style, adjust the mounting location to maintain the proper position of the safety hook face.
- Stryker recommends that, prior to installation, the certified mechanic plan the placement of the safety hook in the rear of the vehicle.
- If the extend (+) button on the control switch remains activated after reaching the set load height, the motor will remain halted until the operator releases the button. Once the button is released, press the extend (+) button again to “jog” the cot height up further.
- The operators must lift the cot weight slightly off of the wheels to use the manual extend or retract while a patient is on the cot.
- Activation of the manual back-up release handle may cause the cot to lower slowly if less than 40 pounds (18 kg) are on the cot.
- Hydraulic fluid will become more viscous when the cot is used for extended periods in cold temperatures. When using the manual back-up release function to extend the base during unloading in cold weather conditions, hold the release handle for approximately one second after the cot wheels touch the ground to minimize sagging of the litter as the cot is removed from the ambulance.
- When operating the manual back-up release handle, avoid rapid lifting or lowering of the base or movement may appear sluggish; lift with a slow constant motion.
- Batteries slowly lose power when not on the charger.
- Inspect the straps and clips for wear between use and replace the strap if it is no longer holding the oxygen bottle.
- The kickstand assembly is configured for an X-frame cot retention system only.
- The kickstand (p/n 6085-002-000) is not compatible with the optional base storage net (p/n 6500-160-000).
- These are general instructions for installation of the Pedi-Mate®. Safe and proper use of the Pedi-Mate® is solely at the discretion of the user. Stryker recommends that all users be trained on the proper use of the Pedi-Mate® before using it in an actual situation. Retain these instructions for future reference. Include them with the product in the event of transfer to new users.
- Failure to follow the cleaning directions when using the specified types of cleaners may void this product's warranty (see [page 91](#)).
- If the arrow on the bottom bracket of the retaining post points toward the head end of the cot, the retaining post is set for an X-frame style cot. If the arrow points toward the foot end of the cot the post is set for an H-frame style cot.

Summary of Safety Precautions

PINCH POINTS

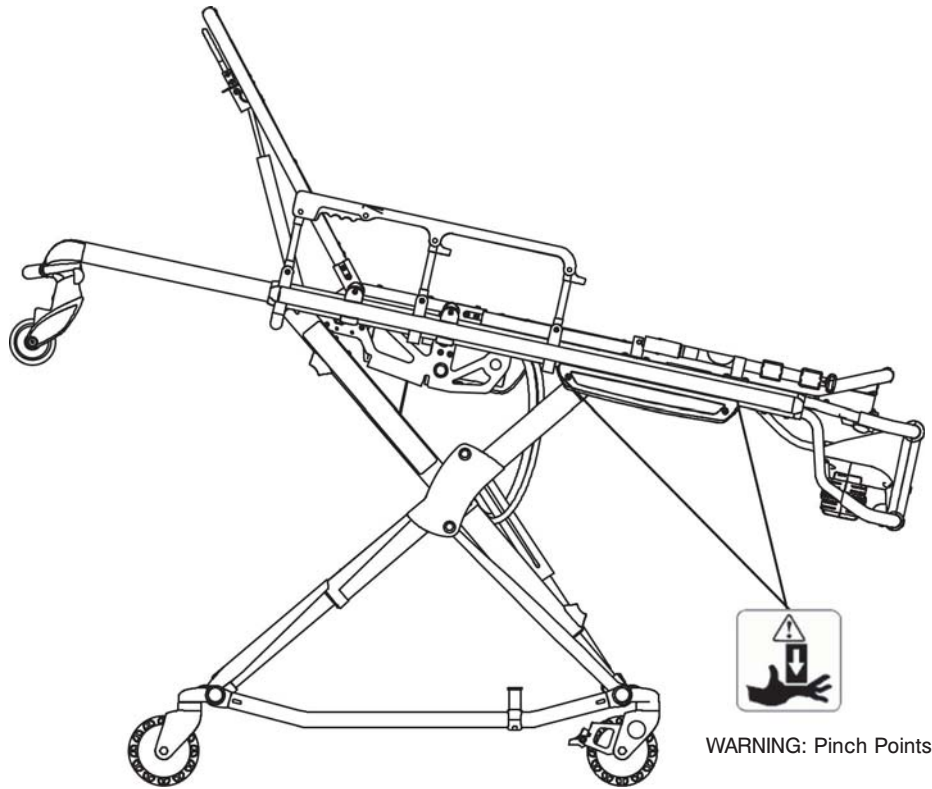

Figure 3: Potential Pinch Points

WARNING

Ensure proper hand placement on hand grips. Hands should be clear of red safety bar pivots while loading and unloading the cot or whenever changing height position of the cot with two or more operators.

Setup Procedures

Ensure that all shipping and packaging materials have been removed from the product(s) prior to use.

Unpack the cartons and check all items for proper operation. It is important that the cot is working properly before it is put into service. Have a qualified service technician use the Product Inspection checklist on [page 21](#) and the operation instructions to check the cot before it is put into service. See Figure 2 on [page 12](#) to identify all of the cot components.

The patient compartment of the vehicle in which the cot will be used must have a:

- Smooth rear edge for cot loading.
- Level floor large enough for the folded cot.
- Stryker Model 6370/6377/6378/6379 or 6371 Cot Fastener System (not included).
- In-fastener shut-off module installed and positioned properly (see [page 25](#)).
- Space to properly install the safety hook.

Note: Loose items or debris on the patient compartment floor can interfere with the operation of the safety hook and cot fastener. Keep the patient compartment floor clear.

When necessary, modify the vehicle to fit the cot. Do not modify the cot.



WARNING

- Improper usage of the cot can cause injury to the patient or operator. Operate the cot only as described in this manual.
- Do not modify the cot or any components of the cot. Modifying the product can cause unpredictable operation resulting in injury to the patient or operator. Modifying the product also voids its warranty (see [page 91](#)).
- Any emergency vehicle to be used with this cot **must** have the in-fastener shut-off system installed (see [page 25](#)).

Note:

- This manual should be considered a permanent part of the cot and should remain with the product even if the cot is subsequently sold.
- Stryker continually seeks advancements in product design and quality. Therefore, while this manual contains the most current product information available at the time of printing, there may be minor discrepancies between your cot and this manual. If you have any questions, please contact Stryker Customer Service or Technical Support at (800) 327-0770 or (269) 324-6500.

Setup Procedures

SETTING COT LOAD HEIGHT AND “JOG” FUNCTION

The cot control mechanism uses height sensors to set the load height stop for the cot. These height sensors match the load wheel height for a specific ambulance deck height.

The cot load height can be set from 26" to 36" (66 cm to 91,4 cm), measured from the ground to the bottom of the load wheel. Determine the cot load height before placing the cot into service. You can modify the cot load height at any time, but you must determine and set the cot load height before the cot is placed into service.

To set the cot load height:

1. Locate the sensor housing on the patient right side of the cot as shown in Figure 4.1.
2. Using a T27 Torx wrench, remove the sensor housing cover by loosening the two (2) screws (one on each end) as shown in Figure 4.2.
3. Adjust the left height sensor only as shown in Figure 4.3.
 - a. Move the sensor to the left to increase the set load height or move the sensor to the right to decrease the set load height.
 - b. Press the retract (-) button to lower the cot to its lowest position, then press the extend (+) button to raise the cot to its highest position.
 - c. Measure the cot height from the bottom of the load wheels to the floor.
Note: Add an additional 1/2" (1,3 cm) to your deck height measurement to allow for variations with patient height and other equipment added to the cot.
 - d. Repeat steps 3a and 3b until the desired cot load height is reached.
4. After the proper load wheel height is set, ensure that all of the height sensor cables are secure and lying flat inside of the housing between the sensors as shown in Figure 4.4.
5. Using a T27 Torx wrench, replace the sensor housing cover by reinstalling the two screws that were removed in step 2.
6. Following completion of the sensor height adjustment, verify that the cot properly engages the safety hook.



Figure 4.1: Sensor Housing



Figure 4.2: Loosening Screws



Figure 4.3: Adjusting Height



Figure 4.4: Securing Cables

CAUTION

The cot can be set at any cot load height position. Establish the required cot load height before placing the cot into service.

Product Inspection

The condition of the cot is the responsibility of the owner. It is important that the cot is working properly before the product is put into service. Have a qualified service technician use the following list and the operation instructions to check the cot before the product is put into service.

The battery must be charged prior to checking the features and condition of the cot.

Item	Routine
Battery	Unpack batteries and charger
	Charge battery according to SMRT Power System instructions (6500-009-101)

The power indicator LED, located at the foot end control enclosure of the cot, is solid green when the battery is fully charged or has adequately charged battery power.

CAUTION

When charging a battery in an ambulance, locate the charger in an enclosed cabinet and out of patient reach during transport.

After the battery is fully charged, inspect the cot for the following points:

Item	Routine	Page
Battery	Charge spare battery (if necessary) according to SMRT Pak instructions	
	Install battery into foot end enclosure - power indicator LED operates	44
	Ensure that the battery remains firmly secured	44
	Release and remove battery from foot end enclosure	44
	Reinstall battery into foot end enclosure	44
Hydraulics	Inspect motor mount - all fasteners secure	73
	Check cylinder attachments at both ends - all fasteners secure	73
	Inspect main cable - all connections secure	73
	Inspect hoses and cylinder seal for leaks	73
Electronic Controls	Check power indicator LED - charged	44
	Extend cot to raised position	32
	Verify "jog" function operates smoothly	32
	Lower to retracted position - cot secures in a mid-height position (motor does not operate)	32
	Determine and set ambulance vehicle load height	20
	Check high speed retract	34
	Extend cot to full height - no drift	32
Manual Back-up Release	Verify the manual back-up release handle functions properly - adjust accordingly	38
	With the cot empty, check the raise/lower function	38
	With the cot loaded with a minimum of 99 pounds (45 kg), check the raise/lower function	38
	With the cot loaded with a minimum of 99 pounds (45 kg), check the load/unload function	38

[Return To Table of Contents](#)

Product Inspection

Item	Routine	Page
Litter	All fasteners secure (reference all assembly drawings)	
	All welds intact - not cracked or broken	
	No bent, broken, or damaged components	
	Inspect hand grips - no defects or tears	
	Verify siderails operate and latch properly	49
	Verify backrest cylinder operates properly through range of motion	49
	Verify the foot rest operates properly	51
	Install body restraints. Restraints intact and operating properly.	46
	No rips or tears in mattress cover	
Head Section	All fasteners secure (reference all assembly drawings)	
	No bent or broken tubing or sheet metal	
	Verify the head section extends and retracts properly	50
	Inspect grip on lift bar - no defects or tears	
	Load wheels are secure and roll freely	
	Verify the safety bar operates properly	
Base	All fasteners secure (reference all assembly drawings)	
	All welds intact - not cracked or broken	
	No bent, broken, or damaged components	
Wheels and Tires	No debris in wheels	
	All wheels secure, rolling and swiveling properly	
	Operate wheel locks (if equipped) - wheel secure when engaged, rolls freely when disengaged	53
Cot Fastener	Inspect the cot retaining post - fasteners secure	86
	Install in-fastener shut-off module. Determine and set in-fastener shut-off position. Verify the cot and cot fastener fit and function properly.	25
	Install vehicle safety hook	27
	Verify the safety bar engages the vehicle safety hook properly	27
Accessories	Verify I.V. pole (if equipped) operates properly	54
	Verify foot end oxygen bottle holder (if equipped) operates properly	
	Verify removable oxygen bottle holder (if equipped) operates properly	
	Verify Pedi-Mate® restraint package (if equipped) is installed properly	60
	Verify equipment hook (if equipped) is installed properly	57
	Verify head extension with pillow (if equipped) is installed properly	
	Verify pocketed backrest storage pouch (if equipped) is installed properly	62
	Verify head end storage flat (if equipped) is installed properly	63
	Verify pillow (if equipped) included	
	Verify 36" restraint extender (if equipped) is included	48
	Verify the transfer flat (if equipped) is included	62

Cot Fastener Installation

The Stryker Cot Fastener Systems are designed to be compatible only with cots which conform to the installation specifications listed on [page 24](#).

 **WARNING**

It is the responsibility of the cot operator to ensure that the cot being used in the Stryker Cot Fastener Systems meets the installation specifications listed on [page 24](#). Injury may result if a non-compatible cot is used in the Stryker Fastener System.

Note: Adjustment of the rail clamp assembly may be required in order to compensate for any variation in the cot retaining post position depending on the cot manufacturer and model number.

For more information about the Stryker Cot Fastener Systems, see the Cot Fastener Operations/Maintenance Manual (6370-009-001).

Cot Fastener Installation

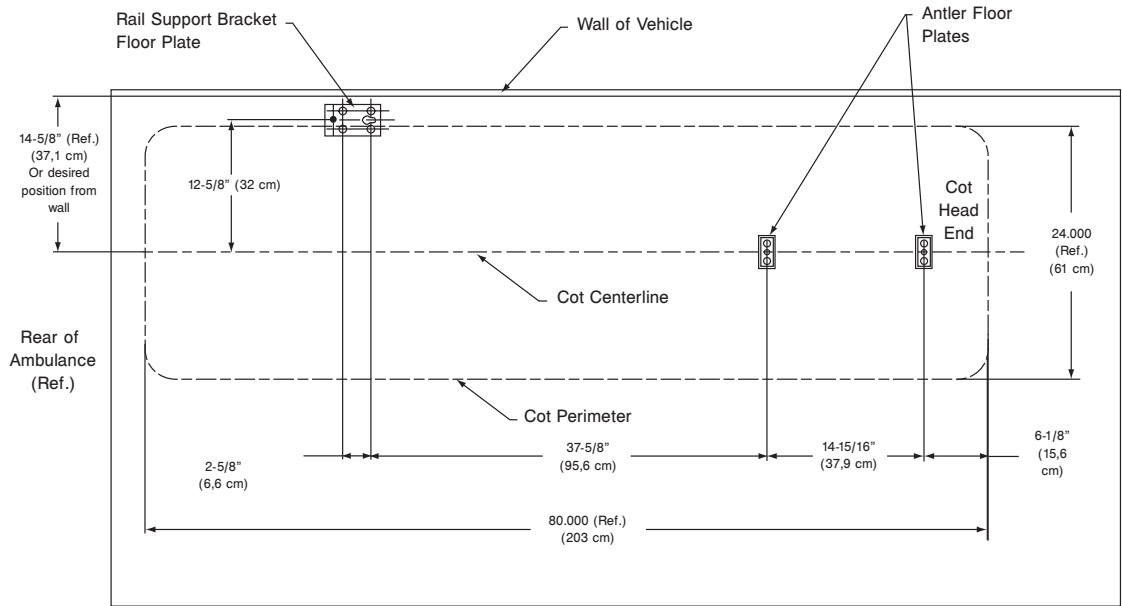

Figure 5: Installation Specifications - Floor Mount Fastener

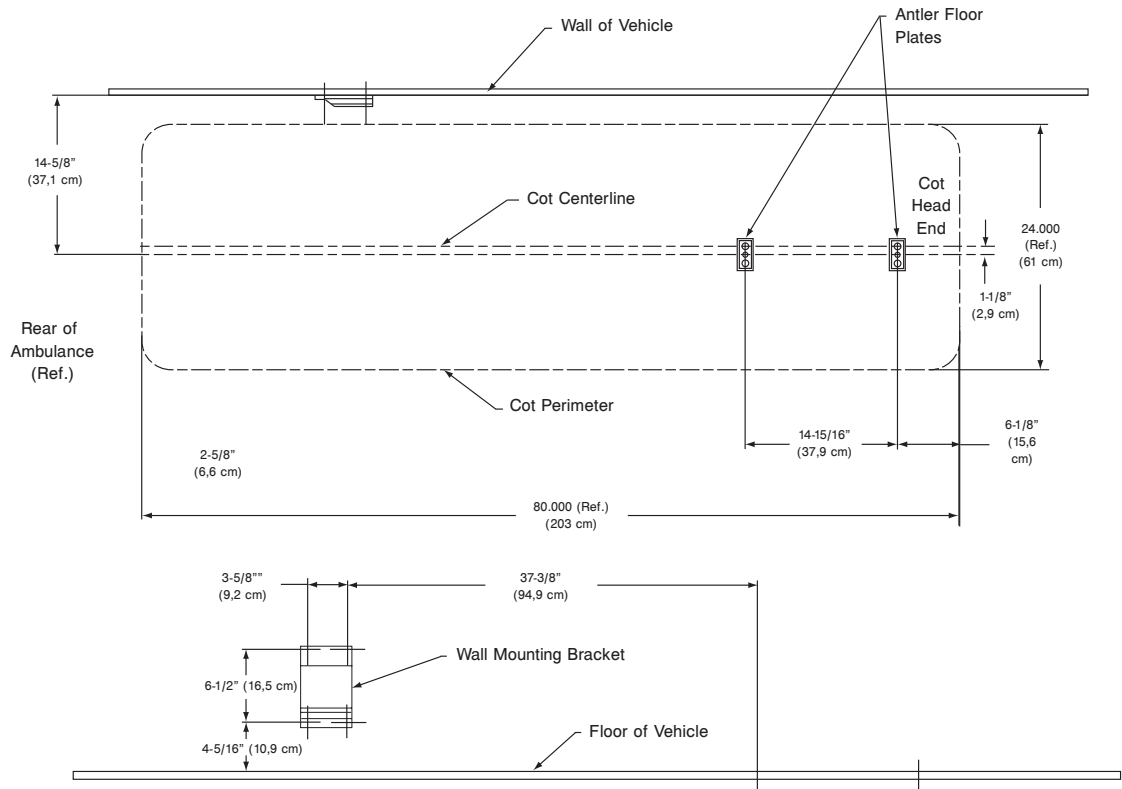

Figure 6: Installation Specifications - Wall Mount Fastener

Cot Fastener Installation

INSTALLING THE IN-FASTENER SHUT-OFF

WARNING

The in-fastener shut-off must be positioned properly before placing the cot into service. Failure to install the in-fastener shut-off may cause injury to the patient or operator and/or damage to the vehicle.

The cot and fastener system have an integrated in-fastener shut-off function that disables the cot motor when the cot is secured into the cot fastener. Securely tighten the bolts on the fastener before installing the shut-off bracket. Install the shut-off bracket onto the rail clamp assembly before putting the cot into service.

1. Place the cot into a loading position (any position where the load wheels of the head section meet the vehicle floor height).
2. Lift the vehicle bumper to the raised position (if equipped).
3. Roll the cot to the open door of the patient compartment.
4. Push the cot forward until the load wheels are on the compartment floor and the safety bar passes the safety hook.
3. For maximum clearance to lift the base, pull the cot back until the safety bar engages the safety hook.
4. Raise the base and push the cot into the patient compartment following the appropriate loading instructions.
5. Engage the **extended** head section of the cot into the cot fastener antler and secure the cot post into the fastener rail clamp.
6. Adjust the shut-off bracket along the rail clamp until the “diamond” on the sensor housing is lined up with the pop rivet head as shown in Figure 7.
7. Using a T27 Torx wrench, securely fasten the bolts to attach the shut-off bracket to the rail clamp assembly.
8. Press the retract (–) button to ensure that the motor does not turn on while the cot is in the fastener. The battery indicator will still illuminate. If the motor turns on, readjust the shut-off bracket.

Note: Align the ‘diamond’ (A) on the sensor housing cover with the pop rivet head (B) on the in-ambulance shut-off.

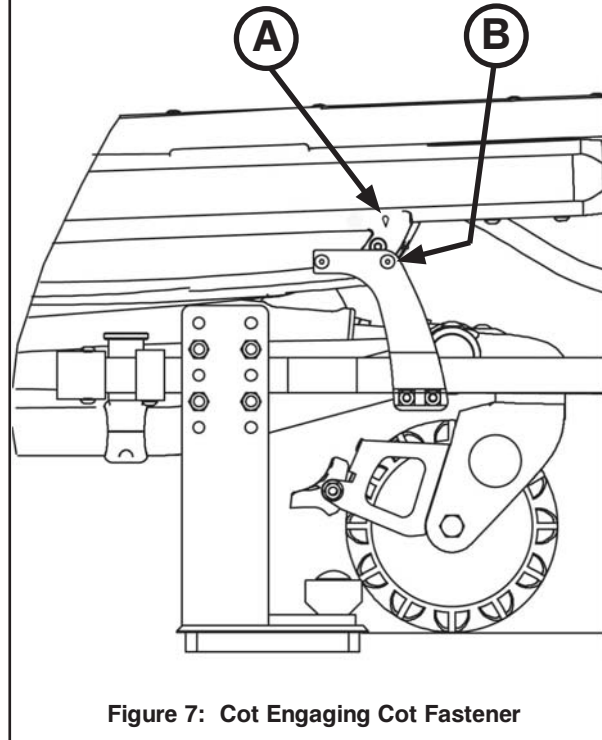

Figure 7: Cot Engaging Cot Fastener

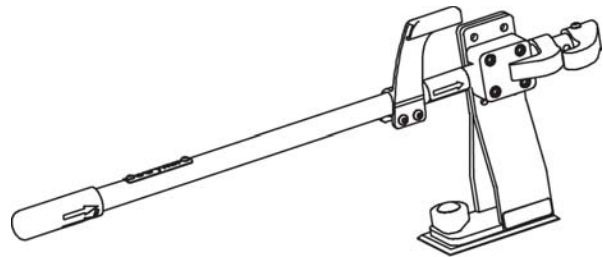

Figure 8: In-Fastener Shut-Off Module

WARNING

- Do not attempt to operate the cot when it is loaded into a cot fastener.
- The in-fastener shut-off is **only** a means for disabling the electronic functionality. Damage to the product and/or injury to the patient and/or operator may occur if used for any other purpose.
- Any emergency vehicle to be used with this cot **must** have the in-fastener shut-off system installed.

Vehicle Safety Hook Selection

The vehicle safety hook is a device that ships with the cot. The cot safety bar and vehicle safety hook are designed to keep the cot from being accidentally removed from the vehicle and to provide increased operator assurance and confidence when loading and unloading. The safety hook was designed for compatibility and proper operation when loading and unloading the cot from a vehicle that is compliant with Federal Regulation KKK-A-1822.

Stryker offers three different types of safety hooks that are ordered and shipped with your cot. These safety hook types are designed to meet the needs of various emergency vehicle configurations, specifically the length and location of the floor structure support that is located in the rear of the vehicle.

Consider the following information when selecting which safety hook is appropriate for your vehicle configuration:

- Determine the location of the floor structure support where there is adequate room to mount the safety hook.
- Ensure that the safety hook can be securely mounted into the back of the vehicle while providing adequate bumper clearance to allow the cot to be loaded and unloaded from the vehicle.
- Note the differences in vehicle design. Each safety hook provides a different mounting location option to maintain the appropriate distance between the face of the safety hook and the edge of the door sill.

Due to the differences in vehicle dimensions and the floor structure support locations, each safety hook requires a different mounting location. See "Vehicle Safety Hook Installation" to determine the correct positioning for safety hook installation.

Note: When replacing an existing safety hook with a new style, adjust the mounting location to maintain the proper position of the safety hook face.

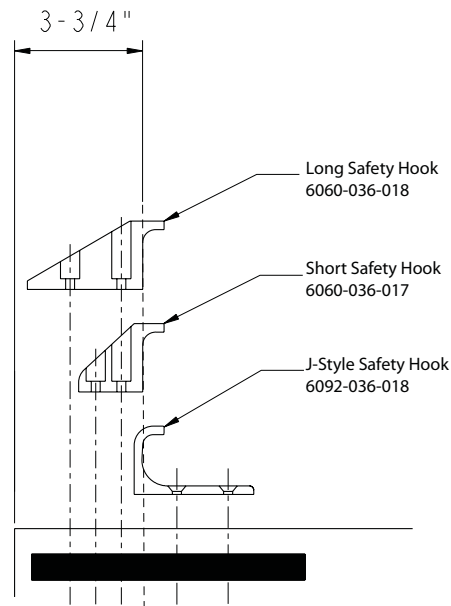

Figure 9: Safety Hook Types

Vehicle Safety Hook Installation

VEHICLE CONFIGURATION

According to federal regulations (reference KKK-A-1822), the bumper height of the vehicle shall be installed equidistant ± 5 cm (2 inches) from the vehicle floor to the ground level, which is defined as the vehicle deck height. The bumper step shall have a minimum depth of 13 cm (5 inches) and a maximum depth of 25 cm (10 inches). If the bumper depth is greater than 18 cm (7 inches), then the bumper must be able to fold. Installation of the safety hook into any vehicle compliant with this federal specification provides adequate clearance for the cot base to lower to its fully extended position. The cot is compatible with all vehicle deck heights (see specifications for maximum load height) as long as the vehicle meets the federal specifications that are outlined in KKK-A-1822.

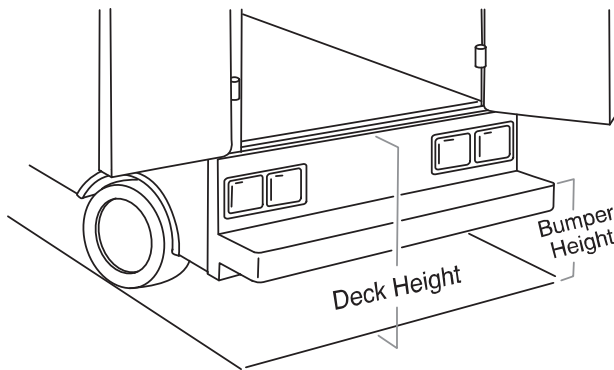

Figure 10.1: Vehicle Deck Height

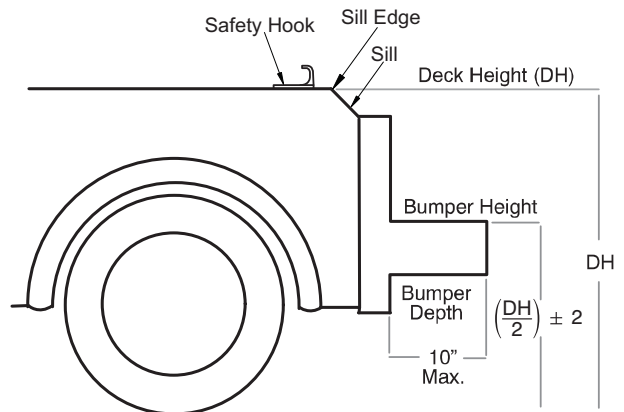

Figure 10.2: Vehicle Deck Height

CAUTION

- Set the cot load height to the proper stop height prior to operation.
- Installation of the safety hook should be done by a certified mechanic familiar with ambulance vehicle construction. Consult the vehicle manufacturer before installing the safety hook and be sure that the installation of the safety hook does not damage or interfere with the brake lines, oxygen lines, fuel lines, fuel tank or electrical wiring of the vehicle.

REQUIRED HARDWARE FOR INSTALLATION OF THE SAFETY HOOK (NOT SUPPLIED)

- (2) Grade 5, 1/4"-20 Socket Head Cap Screws*
- (2) Grade 5, 1/4"-20 Flat Socket Head Cap Screws*
- (2) Flat Washers
- (2) Lock Washers
- (2) 1/4"-20 Nuts

* The length of the socket head cap screws depends on the thickness of the vehicle floor. Use screws that are long enough to go completely through the patient compartment floor, washer and nut by at least two full threads.

Vehicle Safety Hook Installation

WARNING

- Have the vehicle safety hook installed by a certified mechanic. Improper safety hook installation can cause injury to the patient or operator and/or damage to the cot.
- Failure to install the safety hook can cause injury to the patient or operator.
- The face of the safety hook that engages the safety bar should be located at least 3-3/4" from the leading edge of the door sill. After installation, verify that the cot legs lock into the load position without contacting the vehicle bumper.
- To avoid injury, verify that the safety bar has engaged the safety hook before removing the cot from the patient compartment.

Note: Stryker recommends that, prior to installation, the certified mechanic plan the placement of the safety hook in the rear of the vehicle.

Before installing the safety hook into your vehicle, check the front to back and side to side positioning when unloading and loading the cot to ensure that the safety hook will be installed properly. The cot safety bar must engage the safety hook every time, regardless of cot position.

FRONT TO BACK POSITIONING OF THE SAFETY HOOK

1. Select the appropriate safety hook for your vehicle configuration.
2. Position the safety hook at least 3-3/4" from the leading edge of the door sill.
3. Ensure that the safety hook can be securely mounted into the back of the vehicle while providing adequate bumper clearance to allow the cot to be loaded and unloaded from the vehicle.
4. See "Side to Side Positioning of the Safety Hook" to confirm the side to side placement.

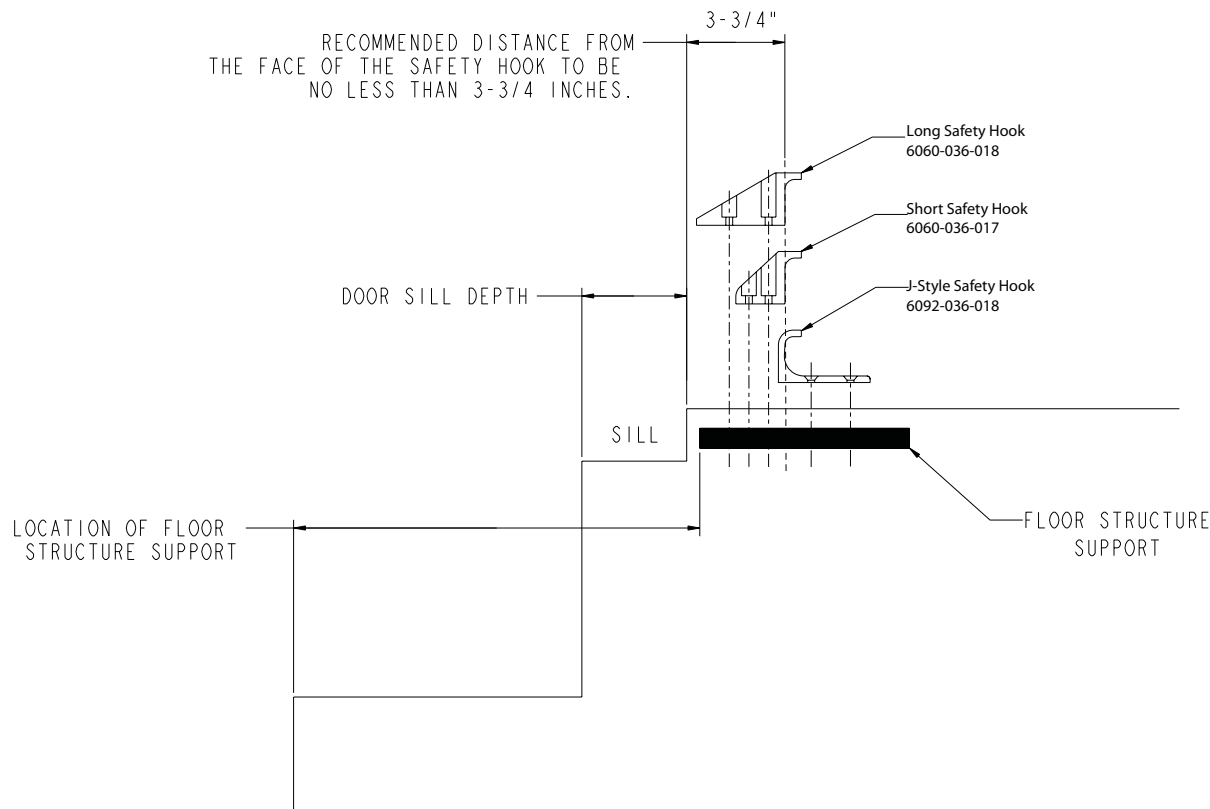

Figure 11: Safety Hook Placement

Vehicle Safety Hook Installation

SIDE TO SIDE POSITIONING OF THE SAFETY HOOK

1. Remove the cot from the fastener and unload it from the vehicle.
2. While the cot is being removed, note the position of the load wheels and the safety bar.
3. Mark the center of the cot safety bar on the vehicle floor.
4. Verify that the position marked in Step 3 is where the safety bar engages the safety hook every time when unloading the cot in a variety of positions (all the way to the left and all the way to the right), regardless of cot position.
 - If the cot safety bar does not engage the safety hook in any of these positions (left, center, or right), modify the vehicle, not the cot or safety hook.
 - If the cot safety bar engages the safety hook every time, install the safety hook.

INSTALLING THE SAFETY HOOK

1. Determine the correct safety hook front to back and side to side positioning, so the cot safety bar engages the safety hook every time.
2. Drill the holes for the socket head cap screws.
3. Fasten the safety hook to the patient compartment floor and verify that the safety hook always engages the cot safety bar regardless of how the cot is unloaded from the vehicle.

WARNING

Verify that the safety hook always engages the cot safety bar regardless of how the cot is unloaded from the vehicle or injury to the patient or operator and/or damage to the cot may occur.

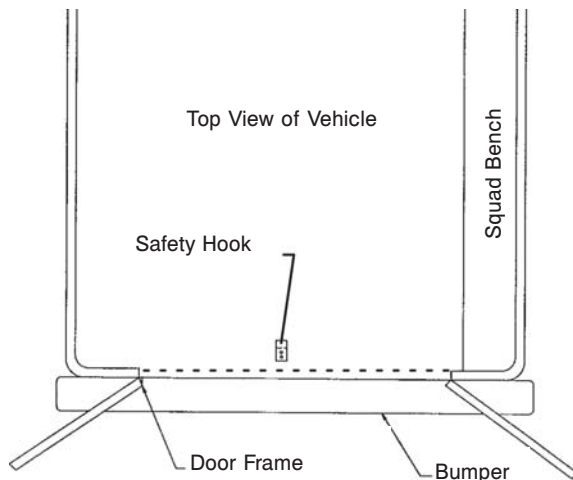

**Figure 12: Safety Hook Placement
(For Reference Only)**

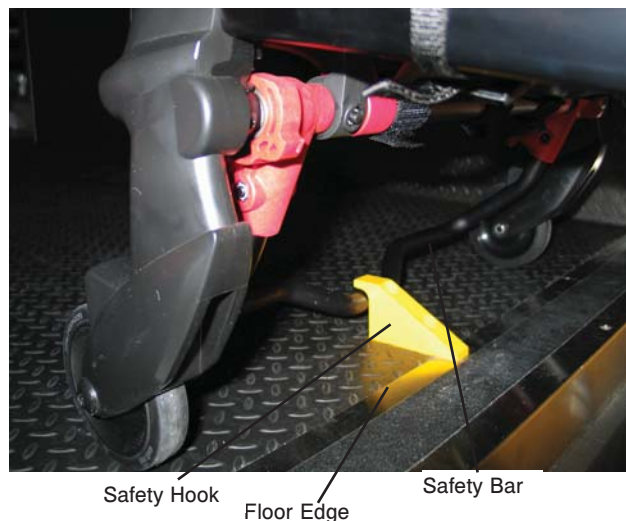

Figure 13: Safety Bar Engaging Safety Hook

WARNING

The cot must have at least 5/8" of clearance between the vehicle bumper and the cot to disengage the safety bar when unloading the cot from the vehicle. Verify that the cot legs lock into the load position before disengaging the safety bar from the safety hook. Failure to properly lock the cot into position can cause injury to the patient or operator and/or damage to the cot.

[Return To Table of Contents](#)

Operation Guide

OPERATING GUIDELINES

- Use the cot only as described in this manual.
- Read all labels and instructions on the cot before using the cot.
- Use a minimum of two (2) trained operators to operate the cot while a patient is on the cot. If additional assistance is needed, see “Using Additional Assistance” on [page 42](#).
- Do not adjust, roll or load the cot into a vehicle without advising the patient. Stay with the patient and control the cot at all times.
- The cot can be transported in any position. Stryker recommends that the operators transport the patient in the lowest comfortable position to maneuver the cot.
- Only use the wheel lock(s) during patient transfer or without a patient on the cot.
- Always use the restraint straps.
- Use properly trained helpers, when necessary, to control the cot.

WARNING

- Improper usage of the cot can cause injury to the patient or operator. Operate the cot only as described in this manual.
- Entanglement in powered cot mechanisms can cause serious injury. Operate the cot only when all persons are clear of the mechanisms.
- Practice changing height positions and loading the cot until operation of the product is fully understood. Improper use can cause injury.
- Do not allow untrained assistants to assist in the operation of the cot. Untrained technicians/assistants can cause injury to the patient or themselves.
- Ensure proper hand placement on hand grips. Hands should be clear of red safety bar pivots while loading and unloading the cot or whenever changing height position of the cot with two or more operators.
- Do not ride on the base of the cot. Damage to the product could occur, resulting in injury to the patient or operator.
- Transporting the cot sideways can cause the cot to tip, resulting in possible damage to the product and/or injury to the patient or operator. Transporting the cot in a lowered position, head or foot end first, minimizes the potential of a cot tip.
- Grasping the cot improperly can cause injury. Keep hands, fingers and feet away from moving parts. To avoid injury, use extreme caution when placing your hands and feet near the base tubes while raising and lowering the cot.
- Any emergency vehicle to be used with this cot **must** have the in-fastener shut-off system installed (see [page 25](#)).

CAUTION

Before operating the cot, clear any obstacles that may interfere and cause injury to the operator or patient.

PROPER LIFTING TECHNIQUES

When lifting the cot and patient, there are five basic guidelines to help you avoid injury:

- Keep your hands close to your body.
- Keep your back straight.
- Coordinate your movements with your partner and lift with your legs.
- Avoid twisting.
- Always operate the cot as described in this manual.

Operation Guide

TRANSFERRING THE PATIENT TO THE COT

To transfer the patient to the cot:

1. Roll the cot to the patient.
2. Place the cot beside the patient and raise or lower the cot to the level of the patient.
3. Lower the siderails and open the restraint straps.
4. Transfer the patient to the cot using accepted EMS procedures.
5. Use all the restraint straps to secure the patient to the cot (see [page 46](#)).
6. Raise the siderails and adjust the backrest and foot rest as necessary.

WARNING

- Always use all restraint straps to secure the patient on the cot. An unrestrained patient may fall from the cot and be injured.
 - Never leave a patient unattended on the cot or injury could result. Hold the cot securely while a patient is on the product.
 - Never apply the optional wheel lock(s) while a patient is on the cot. Tipping could occur if the cot is moved while the wheel lock is applied, resulting in injury to the patient or operator and/or damage to the cot.
 - Siderails are not intended to serve as a patient restraint device. See [page 46](#) for proper restraint strap usage. Failure to utilize the siderails properly could result in patient injury.
 - Hydraulically raising or lowering the cot may temporarily affect electronic patient monitoring equipment. For best results, patient monitoring should be conducted when the cot is idle.
-

ROLLING THE COT

When rolling the cot:

- Make sure that all of the restraint straps are securely buckled around the patient (see [page 46](#)).
- Place the cot in any position for rolling.
- Position an operator at the foot end and one at the head end of the cot **at all times** when rolling the cot with a patient on it.
- Approach door sills and/or other low obstacles squarely and lift each set of wheels over the obstacle separately.

WARNING

- High obstacles such as curbing, steps or rough terrain can cause the cot to tip, possibly causing injury to the patient or operator.
 - If the cot is equipped with the optional kickstand, make sure that the kickstand remains in the retracted position and does not engage during transport.
 - Transporting the cot in lower positions reduces the potential of a cot tip. If possible, obtain additional assistance or take an alternate route.
-

Operation Guide

ADJUSTING THE HEIGHT OF THE COT WITH TWO OPERATORS

Changing the height of the cot while a patient is on the cot requires a minimum of **two (2) trained operators** who are positioned at each end of the cot.

To raise or lower the cot:

1. **Operator 1 (Foot End)** – Grasp the cot frame at the foot end and press either the extend (+) button on the control switch to raise the litter or the retract (–) button on the control switch to lower the litter to the desired position.
2. **Operator 2 (Head End)** – Maintain a firm grip on the outer rail until the cot is securely in the desired position.

WARNING

- Grasping the cot improperly can cause injury. Keep hands, fingers and feet away from moving parts. To avoid injury, use extreme caution when placing your hands and feet near the base tubes while raising and lowering the cot.
- Ensure proper hand placement on hand grips. Hands should be clear of red safety bar pivots while loading and unloading the cot or whenever changing height position of the cot with two or more operators.

Note: If the extend (+) button on the control switch remains activated after reaching the set load height, the motor will remain halted until the operator releases the button. Once the button is released, press the extend (+) button again to “jog” the cot height up further.

CAUTION

Do not “jog” the cot past the established cot load height of the product when the safety bar engages the vehicle safety hook or damage may occur to the product.

Operation Guide

LOADING THE COT INTO A VEHICLE WITH TWO OPERATORS - POWERED METHOD

Loading an occupied cot into a vehicle requires a minimum of **two (2) trained operators**.

WARNING

- Two operators must be present when the cot is occupied.
- Operators must be able to lift the total weight of the patient, cot and any items on the cot.
- The higher an operator must lift the cot, the more difficult it becomes to hold the weight. An operator may need help loading the cot if he/she is too short or if the patient is too heavy to lift safely. The operator must be able to lift the cot high enough for the cot legs to unfold completely and lock when the cot is unloaded. A shorter operator needs to raise their arms higher to enable the undercarriage to unfold.
- Ensure proper hand placement on hand grips. Hands should be clear of red safety bar pivots while loading and unloading the cot or whenever changing height position of the cot with two or more operators.
- There must be a safety hook properly installed in the vehicle so that the bumper does not interfere with the front legs of the base frame.
- Failure to install the safety hook can cause injury to the patient or operator. Install and use the safety hook as described on [page 27](#).

To load the cot into a vehicle with two operators:

1. Place the cot in a loading position (any position where the load wheels meet the vehicle floor height).
2. Lift the vehicle bumper to the raised position (if equipped).
3. Roll the cot to the open door of the patient compartment.
4. Push the cot forward until the load wheels are on the compartment floor and the safety bar passes the safety hook as shown in Figure 14.
5. For maximum clearance to lift the base, pull the cot back until the safety bar engages the safety hook.
6. **Operator 2** – Verify that the bar engages the safety hook.
7. **Operator 1** – Grasp the cot frame at the foot end and press the retract (–) button until the undercarriage of the cot retracts fully as shown in Figure 15.
8. **Operator 2** – Securely grasp the cot outer rail to stabilize the cot during retraction.
9. **Both Operators** – Push the cot into the patient compartment as shown in Figure 16, engaging the cot fastener (not included).

WARNING

When using a standard cot fastener, do not load the cot into the vehicle with the head section retracted. Loading the cot with the head section retracted may cause the product to tip or not engage properly in the cot fastener, possibly causing injury to the patient or operator and/or damage to the cot.

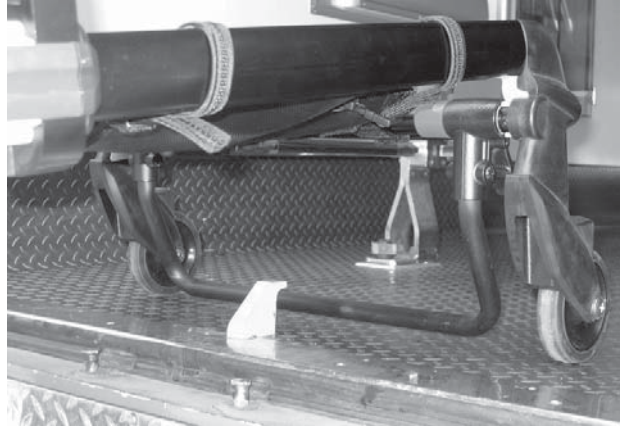

Figure 14: Safety Bar Engaging Safety Hook



Figure 15: 2 Operators - One Pressing the Retract Button



Figure 16: 2 Operators Loading the Cot

Operation Guide

LOADING THE COT INTO A VEHICLE WITH TWO OPERATORS AT THE FOOT END - POWERED METHOD

WARNING

Ensure proper hand placement on hand grips. Hands should be clear of red safety bar pivots while loading and unloading the cot or whenever changing height position of the cot with two or more operators.

1. Place the cot in a loading position (any position where the load wheels meet the vehicle floor height).
2. Lift the vehicle bumper to the raised position (if equipped).
3. Roll the cot to the open door of the patient compartment.
4. Push the cot forward until the load wheels are on the compartment floor and the safety bar passes the safety hook.
5. For maximum clearance to lift the base, pull the cot back until the safety bar engages the safety hook.
6. **Operator 1** – Grasp the cot frame at the foot end.
7. **Operator 2** – Verify that the bar engages the safety hook and return to the foot end.
8. **Both Operators** – Lift the cot together, while Operator 1 presses the retract (-) button until the undercarriage of the cot retracts fully.
9. **Both Operators** – Push the cot into the patient compartment, until the cot engages the cot fastener (not included).

HIGH SPEED RETRACT/EXTEND

The cot is equipped with a high-speed retract mode to expedite loading/unloading the cot into and out of a vehicle.

- The undercarriage **rapidly** retracts toward the highest position once the weight of the cot and patient is off of the wheels. Press the retract (-) button to actuate the control switch.
- The undercarriage **rapidly** extends toward the lowest position once the weight of the cot and patient is off of the wheels. Press the extend (+) button to actuate the control switch.

WARNING

- Whenever the weight of the cot and patient is off of the wheels, the cot will **automatically** enter the high speed retract mode if the retract (-) button is pressed.
 - Once the weight is off of the ground, the operator(s) must support the load of the patient, cot and any accessories. Failure to support the load properly may cause injury to the patient or operator.
-

Operation Guide

LOADING AN EMPTY COT INTO A VEHICLE WITH ONE OPERATOR - POWERED METHOD

Loading an **unoccupied** cot into the emergency vehicle can be accomplished by a single operator.

WARNING

- The one person loading and unloading procedures are for use only with an empty cot. Do not use the procedures when loading/unloading a patient. Injury to the patient or operator could result.
- Ensure proper hand placement on hand grips. Hands should be clear of red safety bar pivots while loading and unloading the cot or whenever changing height position of the cot with two or more operators.

To load an empty cot into a vehicle with one operator:

1. Place the cot into a loading position (any position where the load wheels of the head section meet the vehicle floor height).
2. Lift the vehicle bumper to the raised position (if equipped).
3. Roll the cot to the open door of the patient compartment.
4. Push the cot forward until the load wheels are on the patient compartment floor (Figure 17) and the safety bar passes the safety hook.
5. For maximum clearance to lift the base, pull the cot back until the safety bar engages the safety hook.
6. Grasp the cot frame at the foot end and press the retract (-) button, until the undercarriage of the cot retracts into its highest position as shown in Figure 18).
7. Push the cot into the patient compartment until the cot engages the cot fastener (not included) as shown in Figure 19.

WARNING

When using a standard cot fastener, do not load the cot into the vehicle with the head section retracted. Loading the cot with the head section retracted may cause the product to tip or not engage properly in the cot fastener, possibly causing injury to the patient or operator and/or damage to the cot.



Figure 17: Load Wheels on the Vehicle Floor



Figure 18: Press the Retract Button



Figure 19: Push the Cot into the Vehicle

Operation Guide

UNLOADING THE COT FROM A VEHICLE WITH TWO OPERATORS - POWERED METHOD

Unloading the cot from the vehicle while a patient is on the cot requires a minimum of **two (2) trained operators**, positioned at each end of the cot. Each operator must grasp the cot frame securely.

WARNING

- To avoid injury, verify that the safety bar has engaged the safety hook before removing the cot from the patient compartment.
- Do not pull or lift on the safety bar when unloading the cot. Damage to the safety bar could result and injury to the patient or operator could occur.
- Ensure proper hand placement on hand grips. Hands should be clear of red safety bar pivots while loading and unloading the cot or whenever changing height position of the cot with two or more operators.
- Do not press the extend (+) button until the safety bar has engaged the safety hook.

To unload the cot from a vehicle with two operators:

1. Lift the vehicle bumper to the raised position (if equipped).
2. Disengage the cot from the cot fastener. (For more information about the cot fastener, see [page 24](#)).
3. **Operator 1** – Grasp the cot frame at the foot end. Pull the cot out of the patient compartment until the safety bar engages the safety hook as shown in Figure 20.
4. **Operator 2** - Verify that the bar engages the safety hook.
5. **Operator 2** – Stabilize the cot during the unloading operation by securely grasping the outer rail.
6. **Operator 1** – Depress the extend (+) button to lower the undercarriage to its fully extended position as shown in Figure 21.
7. **Operator 2** – Pull the safety bar release lever forward to disengage the safety bar from the safety hook in the patient compartment as shown in Figure 22.
8. Remove the load wheels from the patient compartment of the vehicle.

CAUTION

- When unloading the cot from the patient compartment, ensure that the caster wheels are safely set on the ground or damage to the product may occur.
- Do not “jog” the cot past the load height while the safety bar is engaged.



Figure 20: 2 Operators Unloading the Cot



Figure 21: 2 Operators - One Pressing the Extend Button

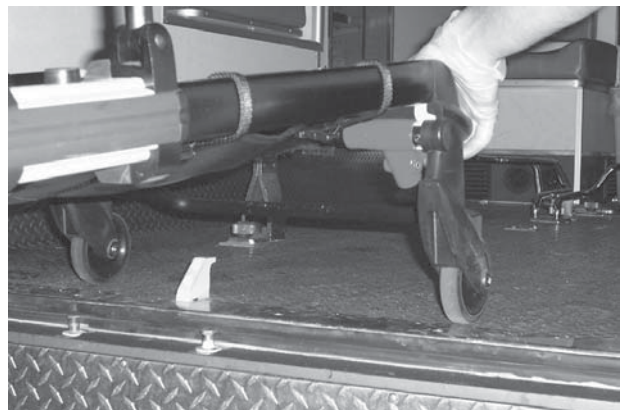

Figure 22: Disengaging the Safety Bar

Operation Guide

UNLOADING AN EMPTY COT FROM A VEHICLE WITH ONE OPERATOR - POWERED METHOD

Unloading an **unoccupied** cot from a vehicle can be accomplished by a single operator.

WARNING

- The one person loading and unloading procedures are for use only with an empty cot. Do not use the procedures when loading or unloading a patient. Injury to the patient or operator could result.
- Do not pull or lift on the safety bar when unloading the cot. Damage to the safety bar could result and injury to the patient or operator could occur.
- Ensure proper hand placement on hand grips. Hands should be clear of red safety bar pivots while loading and unloading the cot or whenever changing height position of the cot with two or more operators.

To unload an empty cot from a vehicle with one operator:

1. Lift the vehicle bumper to the raised position (if equipped).
2. Disengage the cot from the cot fastener. (For more information about the cot fastener, see [page 24](#)).
3. Grasp the cot frame at the foot end.
4. Pull the cot from the vehicle until the safety bar engages the safety hook as shown in Figure 23.
5. Depress the extend (+) button to lower the undercarriage to its fully extended position as shown in Figure 24.
6. Disengage the safety bar from the safety hook by pulling the safety bar release lever forward and roll the cot out of the vehicle as shown in Figure 25.
7. Remove the load wheels from the patient compartment of the vehicle.

CAUTION

- When unloading the cot from the patient compartment, ensure that the caster wheels are safely set on the ground or damage to the product may occur.
- Do not “jog” the cot past the load height while the safety bar is engaged.



Figure 23: Pull the Cot out of the Vehicle



Figure 24: Press the Extend Button



Figure 25: Roll the Cot out of the Vehicle

Operation Guide

USING THE MANUAL OVERRIDE

In the event of loss of electrical function, the cot is equipped with a manual override to allow manual operation of the product until electrical functionality is restored. You can use the red manual back-up release handle to raise or lower the cot.

The **red** manual back-up release handle (A) is located along the patient left side of the lower lift bar at the foot end of the cot as shown in Figure 26.

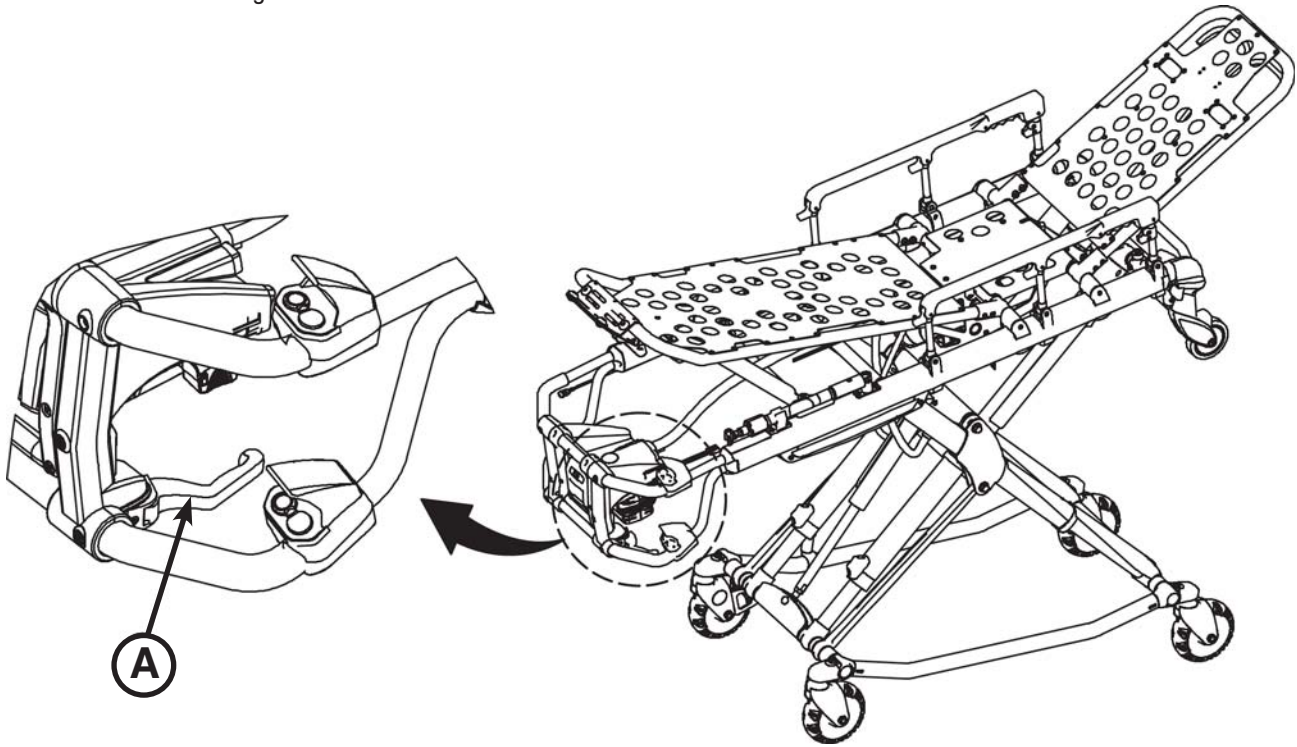

Figure 26: Manual Back-Up Release Handle

To raise or lower the cot with the manual back-up release handle:

1. **Both Operators** – Lift the cot during the raise/lower operation to support the weight of the cot at each end.
2. **Operator 1 (Foot End)** – Pull the manual back-up release handle toward the lift bar. While the manual back-up release handle is pulled, raise or lower the cot to the desired position and then release the handle to lock the cot into position.

Note:

- The operators must lift the cot weight slightly off of the wheels to use the manual extend or retract while a patient is on the cot.
- Activation of the manual back-up release handle may cause the cot to lower slowly if less than 40 pounds (18 kg) are on the cot.
- Hydraulic fluid will become more viscous when the cot is used for extended periods in cold temperatures. When using the manual back-up release function to extend the base during unloading in cold weather conditions, hold the release handle for approximately one second after the cot wheels touch the ground to minimize sagging of the litter as the cot is removed from the ambulance.

Operation Guide

LOADING THE COT INTO A VEHICLE WITH TWO OPERATORS - MANUAL METHOD

Loading an occupied cot into a vehicle requires a minimum of **two (2) trained operators**.

WARNING

- Two operators must be present when the cot is occupied.
- Operators must be able to lift the total weight of the patient, cot and any items on the cot.
- The higher an operator must lift the cot, the more difficult it becomes to hold the weight. An operator may need help loading the cot if he/she is too short or if the patient is too heavy to lift safely. The operator must be able to lift the cot high enough for the cot legs to unfold completely and lock when the cot is unloaded. A shorter operator needs to raise their arms higher to enable the undercarriage to unfold.
- Ensure proper hand placement on hand grips. Hands should be clear of red safety bar pivots while loading and unloading the cot or whenever changing height position of the cot with two or more operators.
- There must be a safety hook properly installed in the vehicle so that the bumper does not interfere with the front legs of the base frame.
- Failure to install the safety hook can cause injury to the patient or operator. Install and use the safety hook as described on [page 27](#).

To load the cot into a vehicle with two operators using the manual back-up release handle:

1. Place the cot in a loading position (any position where the load wheels meet the vehicle floor height).
2. Lift the vehicle bumper to the raised position (if equipped).
3. Roll the cot to the open door of the patient compartment.
4. Push the cot forward until the load wheels are on the patient compartment floor and the safety bar passes the safety hook.
5. For maximum clearance to lift the base, pull the cot back until the safety bar engages the safety hook.
6. **Operator 2** – Verify that the bar engages the safety hook.
7. **Operator 1** – Grasp the cot frame at the foot end. Lift the foot end of the cot until the weight is off of the cot base. Squeeze and hold the release handle as shown in Figure 27.
8. **Operator 2** – Stabilize the cot by placing your hand on the outer rail. Grasp the base frame. After the foot end operator has lifted the cot and squeezed the release handle, raise the undercarriage until it stops in the highest position and hold it there as shown in Figure 28.
9. **Both Operators** – Push the cot into the patient compartment, engaging the cot fastener (not included) as shown in Figure 29.

Note: When operating the manual back-up release handle, avoid rapid lifting or lowering of the base or movement may appear sluggish; lift with a slow constant motion.



Figure 27: Manual Back-up Release Handle



Figure 28: 2 Operators - One Lifting Base



Figure 29: Push the Cot Into the Vehicle

Operation Guide

UNLOADING THE COT FROM A VEHICLE WITH TWO OPERATORS - MANUAL METHOD

Unloading the cot from the vehicle while a patient is on the cot requires a minimum of **two (2) trained operators**, positioned at each end of the cot as shown in Figure 30. Each operator must grasp the cot frame securely.

WARNING

- To avoid injury, verify that the safety bar has engaged the safety hook before removing the cot from the patient compartment.
- Do not pull or lift on the safety bar when unloading the cot. Damage to the safety bar could result and injury to the patient or operator could occur.
- Ensure proper hand placement on hand grips. Hands should be clear of red safety bar pivots while loading and unloading the cot or whenever changing height position of the cot with two or more operators.

To unload the cot from a vehicle with two operators:

1. Lift the vehicle bumper to the raised position (if equipped).
2. Disengage the cot from the cot fastener. (For more information about the cot fastener, see [page 24](#)).
3. **Operator 1** – Grasp the cot frame at the foot end. Pull the manual back-up release handle to lower the undercarriage to its fully extended position (Figure 31). Pull the cot out of the patient compartment until the safety bar engages the safety hook.
4. **Operator 2** - Verify that the bar engages the safety hook.
5. **Operator 2** – Stabilize the cot during the unloading operation by securely grasping the outer rail.
6. **Operator 2** – Pull the safety bar release lever forward to disengage the safety bar from the safety hook in the patient compartment (Figure 32).
7. Remove the load wheels from the patient compartment of the vehicle.

CAUTION

When unloading the cot from the patient compartment, ensure that the caster wheels are safely set on the ground or damage to the product may occur.



Figure 30: 2 Operators Unloading the Cot



Figure 31: 2 Operators - One Pulling the Manual Back-up Release Handle

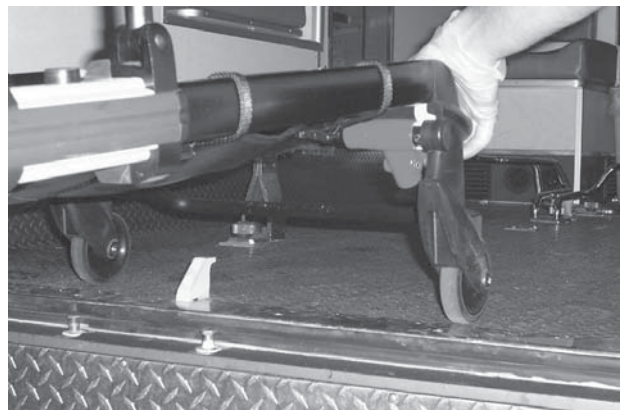

Figure 32: Disengaging the Safety Bar

Operation Guide

UNLOADING AN EMPTY COT FROM A VEHICLE WITH ONE OPERATOR - MANUAL METHOD

Unloading an **unoccupied** cot from a vehicle can be accomplished by a single operator.

WARNING

- The one person loading and unloading procedures are for use only with an empty cot. Do not use the procedures when loading or unloading a patient. Injury to the patient or operator could result.
 - Do not pull or lift on the safety bar when unloading the cot. Damage to the safety bar could result and injury to the patient or operator could occur.
 - Ensure proper hand placement on hand grips. Hands should be clear of red safety bar pivots while loading and unloading the cot or whenever changing height position of the cot with two or more operators.
-

To unload an empty cot from a vehicle with one operator:

1. Lift the vehicle bumper to the raised position (if equipped).
2. Disengage the cot from the cot fastener. (For more information about the cot fastener, see [page 24](#)).
3. Grasp the cot frame at the foot end.
4. Pull the cot from the vehicle until the safety bar engages the safety hook as shown in Figure 33.
5. Pull the manual back-up release handle to lower the undercarriage to its fully extended position as shown in Figure 34.
6. Disengage the safety bar from the safety hook by pulling the safety bar release lever forward and roll the cot out of the vehicle as shown in Figure 34.
7. Remove the load wheels from the patient compartment of the vehicle.



Figure 33: Pull the Cot out of the Vehicle



Figure 34: Pull the Manual Back-up Release Handle and Roll the Cot out of the Vehicle

CAUTION

When unloading the cot from the patient compartment, ensure that the caster wheels are safely set on the ground or damage to the product may occur.

Operation Guide

USING ADDITIONAL ASSISTANCE

	Changing Levels	Rolling	Loading/Unloading
Two Operators Two Helpers			
Two Operators Four Helpers			

WARNING

Ensure proper hand placement on hand grips. Hands should be clear of red safety bar pivots while loading and unloading the cot or whenever changing height position of the cot with two or more operators.

Operation Guide

REMOVING AND REPLACING A SMRT PAK

The cot is supplied with two removable 24V SMRT Paks as the power source.

See the SMRT Power System Operations/Maintenance manual (6500-009-101) for additional SMRT Pak and SMRT Charger information.

WARNING

- To avoid risk of electric shock, never attempt to open the battery pack for any reason. If the battery pack case is cracked or damaged, do not insert it into the charger. Return damaged battery packs to a service center for recycling.
 - Do not remove the battery when the cot is activated.
 - Avoid direct contact with a wet battery or battery enclosure. Contact may cause injury to the patient or operator.
-

To remove the SMRT Pak:

1. Press the RED one hand release button (C) or press the battery release button (A) to release the SMRT Pak (B) from the cot as shown in Figure 35.
2. Slide the released SMRT Pak out of the enclosure.

To reinstall or replace the SMRT Pak:

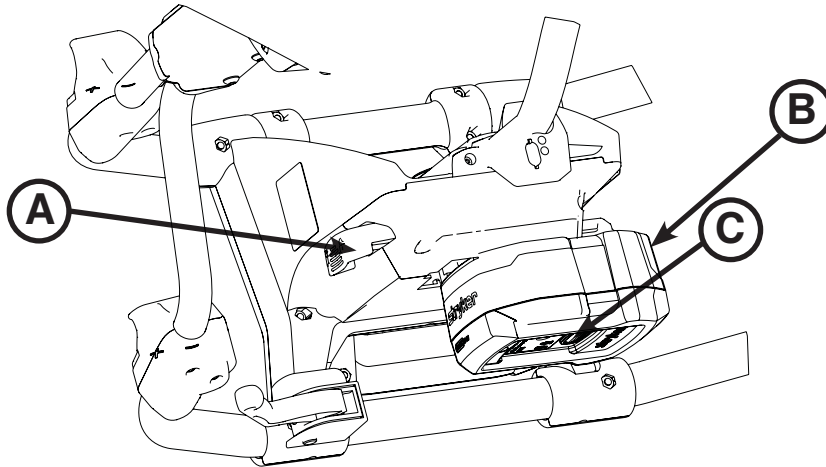

Figure 35: SMRT Pak Removal and Replacement

1. Align the tabs in the battery enclosure.
2. Push the SMRT Pak into the enclosure until the latch clicks into place.
 - The cot power indicator LED is solid GREEN if the SMRT Pak is fully charged and ready.
 - The cot power indicator LED flashes RED if the SMRT Pak needs to be recharged or replaced.

Note: Batteries slowly lose power when not on the charger.

CAUTION

Remove the battery if the cot is not going to be used for an extended period of time (more than 24 hours).

Operation Guide

USING THE BATTERY POWER INDICATOR

To check the battery power level, depress **lightly** on the retract (–) switch (A) to activate the power indicator LED (B) as shown in Figures 36 and 37.

The power indicator LED is located at the foot end control enclosure as shown in Figure 37, represented by a battery icon.

- The indicator LED is solid green when the battery is fully charged or has adequately charged battery power.
- The indicator LED flashes red when the battery needs to be recharged or replaced.

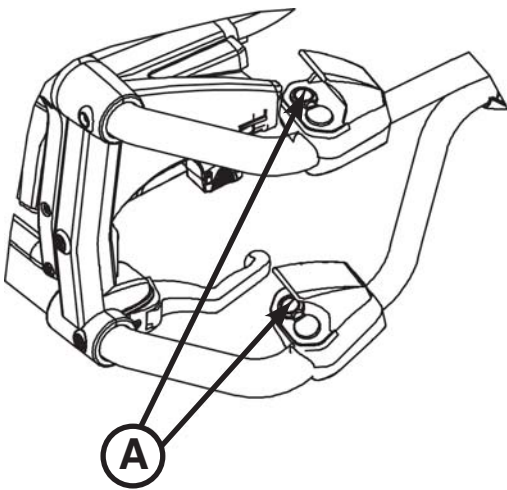

Figure 36: Retract Switches

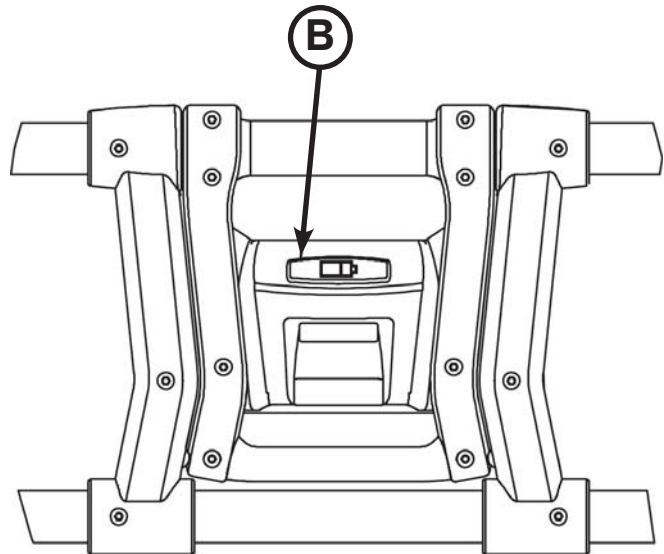

Figure 37: Power Indicator LED

WARNING

- To avoid risk of electric shock, never attempt to open the battery pack for any reason. If the battery pack case is cracked or damaged, do not insert it into the charger. Return damaged battery packs to a service center for recycling.
- Do not remove the battery when the cot is activated.
- Avoid direct contact with a wet battery or battery enclosure. Contact may cause injury to the patient or operator.

CAUTION

- Only use the battery and charger as specified.
- The cot is not for use with an AC adapter.
- When charging a battery in an ambulance, locate the charger in an enclosed cabinet and out of patient reach during transport.
- Ensure that the battery is fully charged prior to placing into service. An uncharged or depleted battery may cause poor cot performance.

See the SMRT Power System Operations/Maintenance manual (6500-009-101) for additional SMRT Pak and SMRT Charger information.

Operation Guide

USING THE HOUR METER

The hour meter, located on the foot end control enclosure as shown in Figure 38, indicates the amount of time (HHH.H hours) that the hydraulics have been activated. You can use the hour meter to determine the frequency for preventative maintenance procedures as listed on [page 67](#).

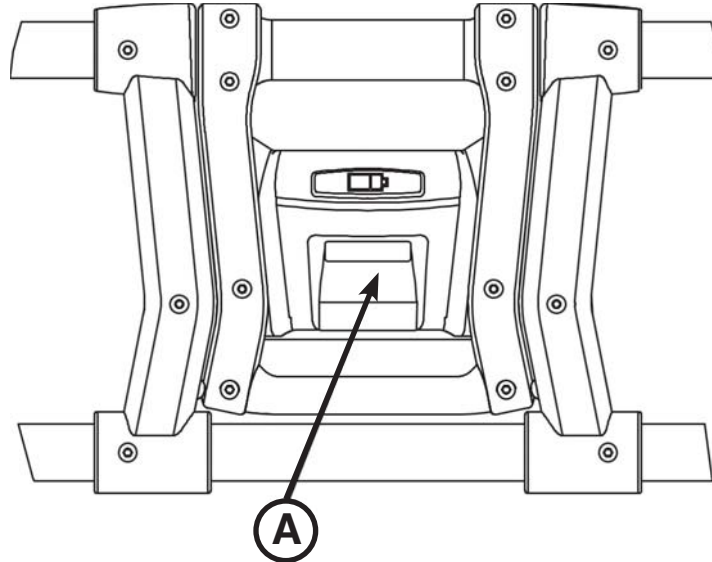

Figure 38: Hour Meter

Operation Guide

USING RESTRAINT STRAPS

WARNING

Always use all restraint straps to secure the patient on the cot. An unrestrained patient may fall from the cot and be injured.

Always secure the patient on the cot with all of the restraint straps. Buckle the restraints across the patient's chest/shoulders, waist and legs as shown in Figure 39.1. Keep the restraint straps buckled when the cot is not being used with a patient to avoid damage to the buckles and straps.

WARNING

Do not attach restraints to the base or cross tubes, improper restraint attachment could result in damage to the cot further resulting in injury to the patient or operator.

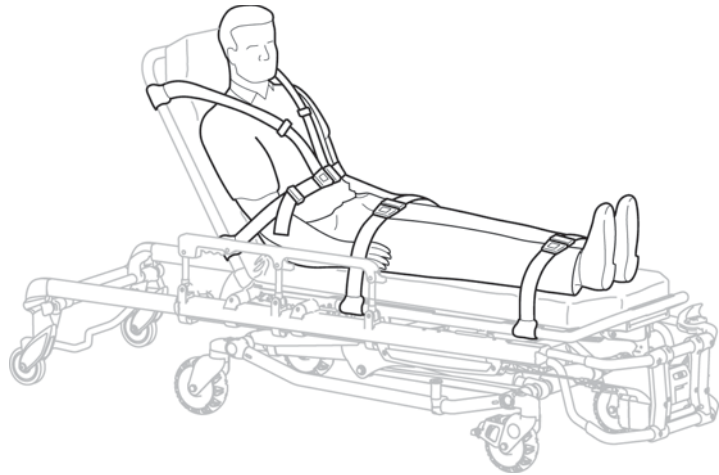

Figure 39.1: Safety Restraints

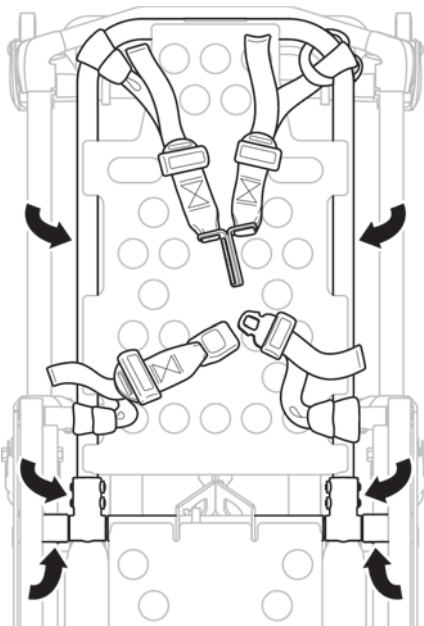

Figure 39.2: Head Section Restraints

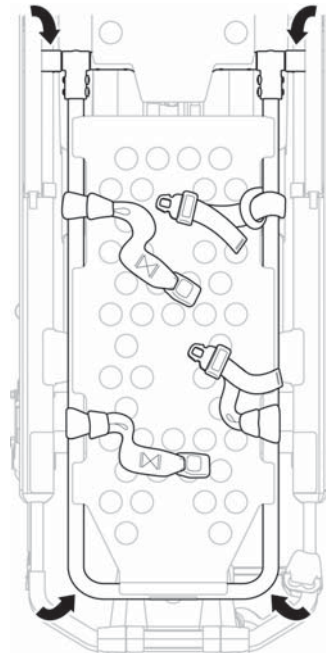

Figure 39.3: Foot Section Restraints

Wrap the strap around the cot frame and back through the loop on the end of the strap as shown in Figures 40.2 and 40.3. The arrows indicate alternate attachment areas.

When attaching the restraint straps to the cot, the attachment points should provide both strong anchorage and proper restraint position while not interfering with equipment and accessories.

Operation Guide

USING RESTRAINT STRAPS (CONTINUED)

CAUTION

Ensure that the restraints are not entangled in the base frame when raising and lowering the cot.

When the cot is put into service, open the restraints and place them at either side of the cot until the patient is positioned on the cot mattress. Lengthen the restraints, buckle them around the patient and shorten them until the required tightness is achieved.

- **To open the restraint**, press the red button (A) on the front of the buckle “receiver”. This releases the buckle latch plate (B) which can then be pulled out of the receiver (Figure 41.1).
- **To close the restraint**, push the latch plate into the receiver until a “click” is heard. When fastening the chest restraint ensure that the latch plate passes through both links (C) on the shoulder strap (Figure 40.1).
- **To lengthen the restraint**, grasp the buckle latch plate, turn it at an angle to the webbing, then pull it out (Figure 40.2). A hemmed tab at the end of the webbing prevents the latch plate from coming off of the strap.
- **To shorten the restraint**, grasp the hemmed tab and pull the webbing back through the latch plate until the required tightness is achieved (Figure 40.3).

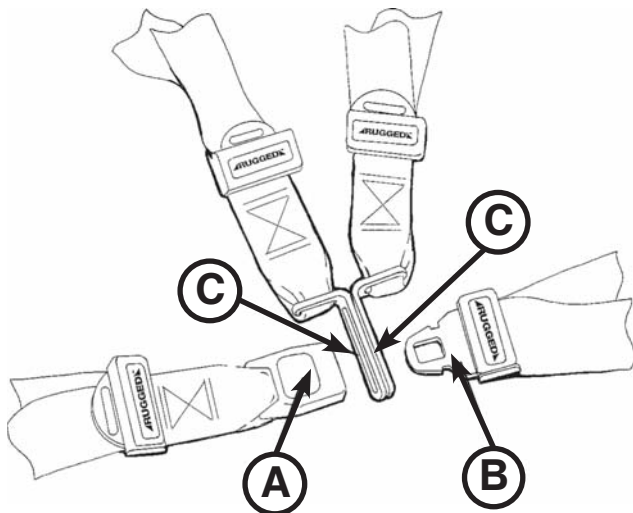

Figure 40.1: Buckling the Safety Restraints



Figure 40.2: Lengthening the Safety Restraint

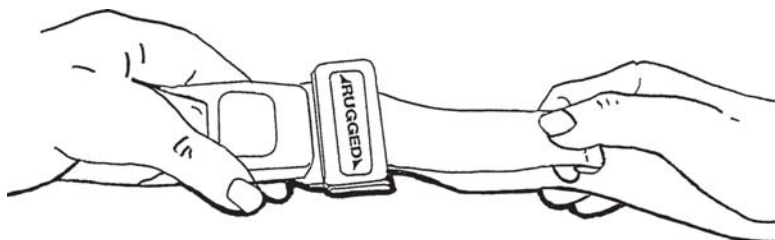

Figure 40.3: Shortening the Safety Restraint

Whenever a restraint is buckled on a patient, verify that the latch plate is fully engaged and any extra webbing is not tangled in the cot or hanging loose.

Inspect the restraints **at least** once a month (more frequently if used heavily). Inspection should include checking for a bent or broken receiver or latch plate, torn or frayed webbing, etc. Any restraint showing wear or not operating properly **must** be replaced immediately.

[Return To Table of Contents](#)

Operation Guide

USING THE OPTIONAL RESTRAINT BELT EXTENSION

Use the restraint belt extension, as shown in Figure 41, for extra length when buckling the lap belt around large patients.

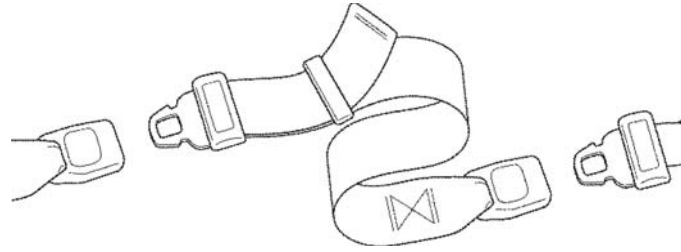

Figure 41: Attaching the Restraint Belt Extension

Operation Guide

OPERATING THE SIDERAILS

To raise the siderails, as shown in Figure 42, lift up on the siderail until the latch clicks and the siderail locks into place. When a patient is on the cot, always keep the siderails in the raised position unless the patient is being transferred.

To lower the siderails, squeeze handle (B) to release the siderail latch. Guide the siderail down toward the foot end until flat.

WARNING

Siderails are not intended to serve as a patient restraint device. See [page 46](#) for proper restraint strap usage. Failure to utilize the siderails properly could result in patient injury.

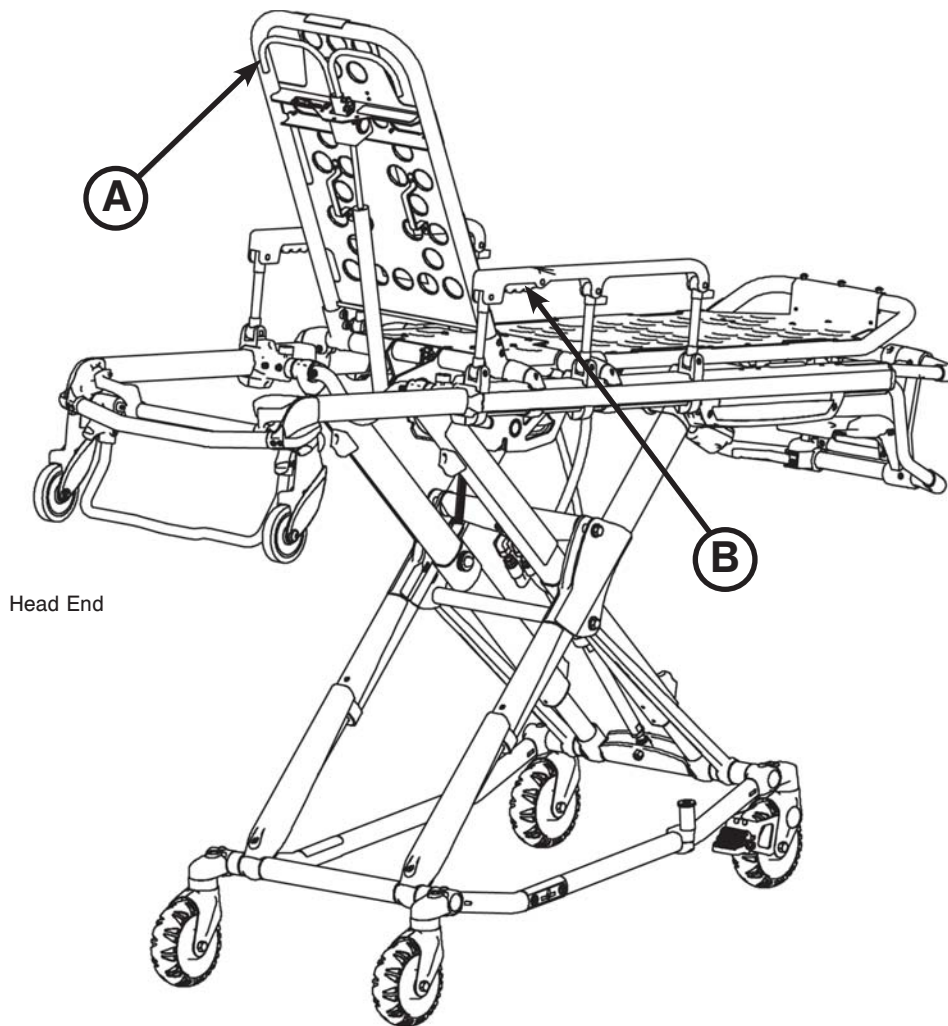

Figure 42: Backrest Elevated and Siderails Raised

OPERATING THE BACKREST

To raise the backrest, as shown in Figure 42, squeeze handle (A) for pneumatic assist in lifting the backrest to the desired height.

To lower the backrest, squeeze handle (A) and push down on the backrest frame until the backrest has reached the desired height.

[Return To Table of Contents](#)

Operation Guide

OPERATING THE RETRACTABLE HEAD SECTION

The head section telescopes from a first position suitable for loading the cot into an emergency vehicle to a second position retracted within the litter frame. When retracted, the cot can roll in any direction on the caster wheels even in the lowest position, allowing for improved mobility and maneuverability.

To extend the head section:

1. Grasp the outer rail with one hand for support and pull the lever (A), rotating the lever toward the head end of the cot to release the head section from the locked position.
2. While holding the handle (A) in the released position, pull the head section away from the litter frame, lengthening the head section until it engages in the fully extended position.
3. Release lever (A) to lock the head section in the extended position.

To retract the head section:

1. Grasp the outer rail with one hand for support and release the lever (A), rotate the lever toward the head end of the cot to release the head section from the locked position.
2. While holding the handle (A) in the released position, push the head section toward the litter frame, retracting the head section until it engages in the retracted position.
3. Release lever (A) to lock the head section in the retracted position.

WARNING

- To avoid injury, always verify that the head section is locked into place prior to operating the cot.
- When using a standard cot fastener, do not attempt to load the cot into the patient compartment with the head section retracted. Loading the cot with the head section retracted may cause the product to tip or not engage properly in the cot fastener, possibly causing injury to the patient or operator and/or damage to the product.

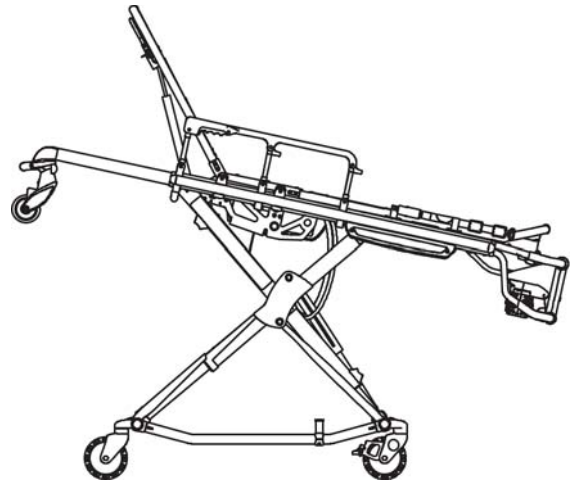

Figure 43.1: Head Section Extended

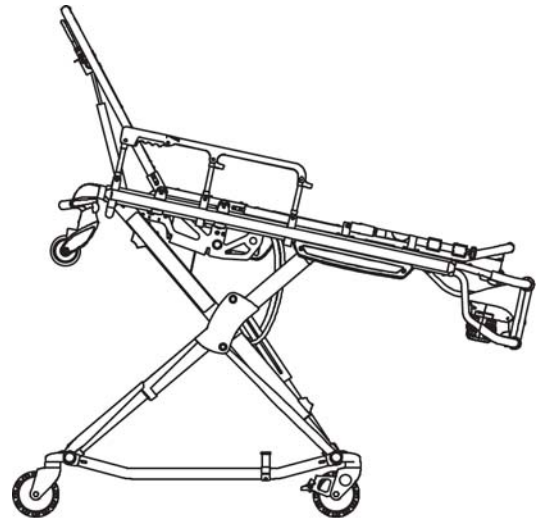

Figure 43.2: Head Section Retracted

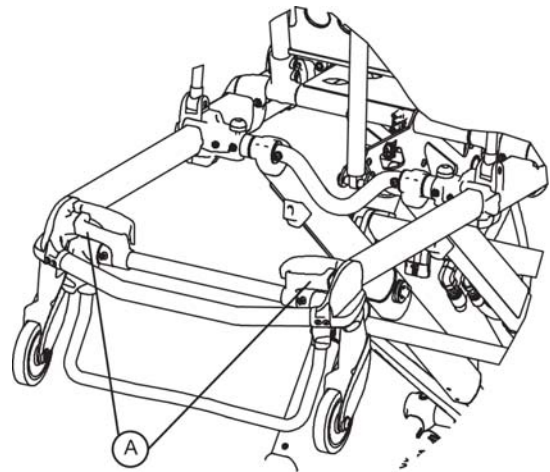

Figure 43.3: Head Section Release Handles

Operation Guide

ADJUSTING THE FOOTREST

The footrest is adjustable to elevate the patient's legs (see Figure 44).

To raise the footrest, lift the footrest frame (A) as high as possible. The support bracket engages automatically when released.

To lower the footrest, lift the footrest frame (A) and while holding the frame, lift up on the release handle (B) until the bracket disengages. Lower the footrest until flat.

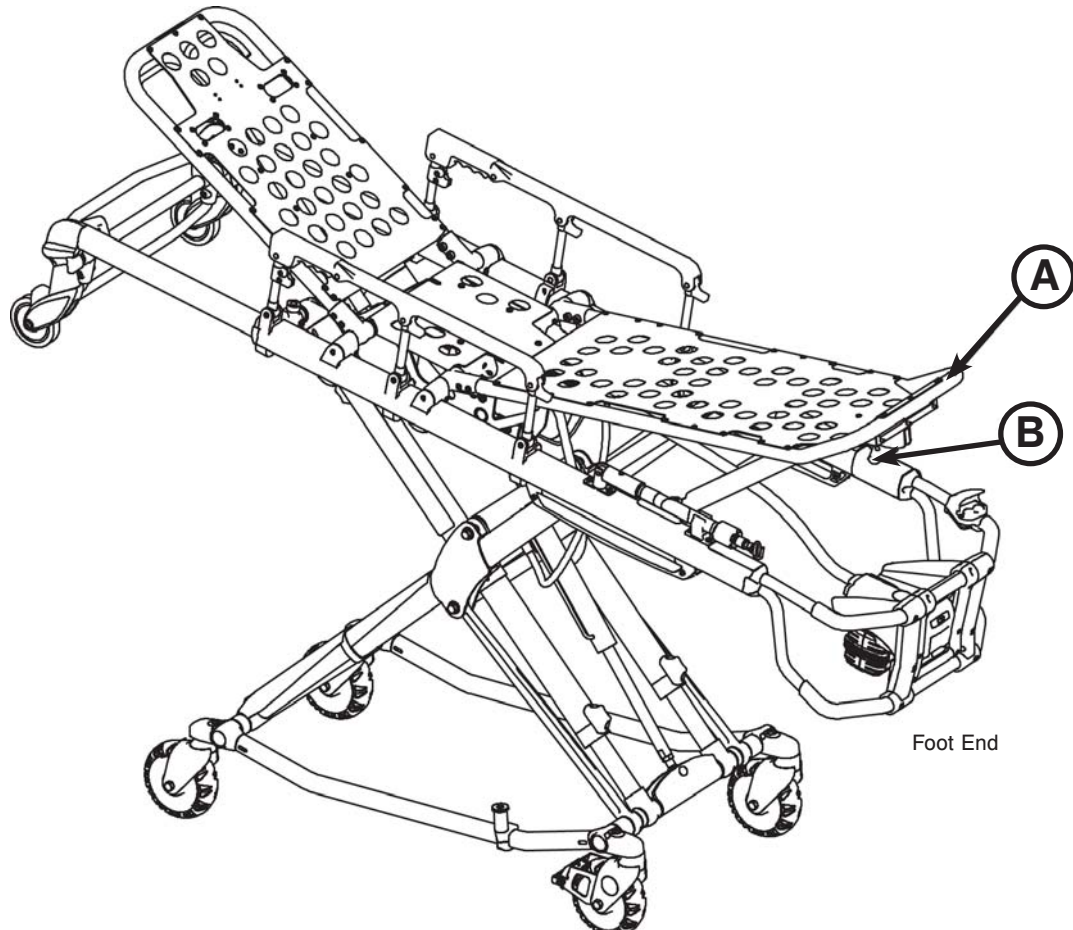

Figure 44: Footrest Elevated

Operation Guide

RAISING AND LOWERING THE OPTIONAL GATCH

To raise the gatch, lift either of the red lifting loops (A) until the gatch is in its fully raised position, then slowly lower the gatch to allow the support bracket to engage into the locking mechanism. Make sure that the lock is fully engaged before releasing the lifting loop.

To lower the gatch, lift either of the red lifting loops (A) to relieve pressure on the locking mechanism and while holding the loop, lift up on the red release handle (B) until the bracket disengages. Lower the gatch to the flat position.

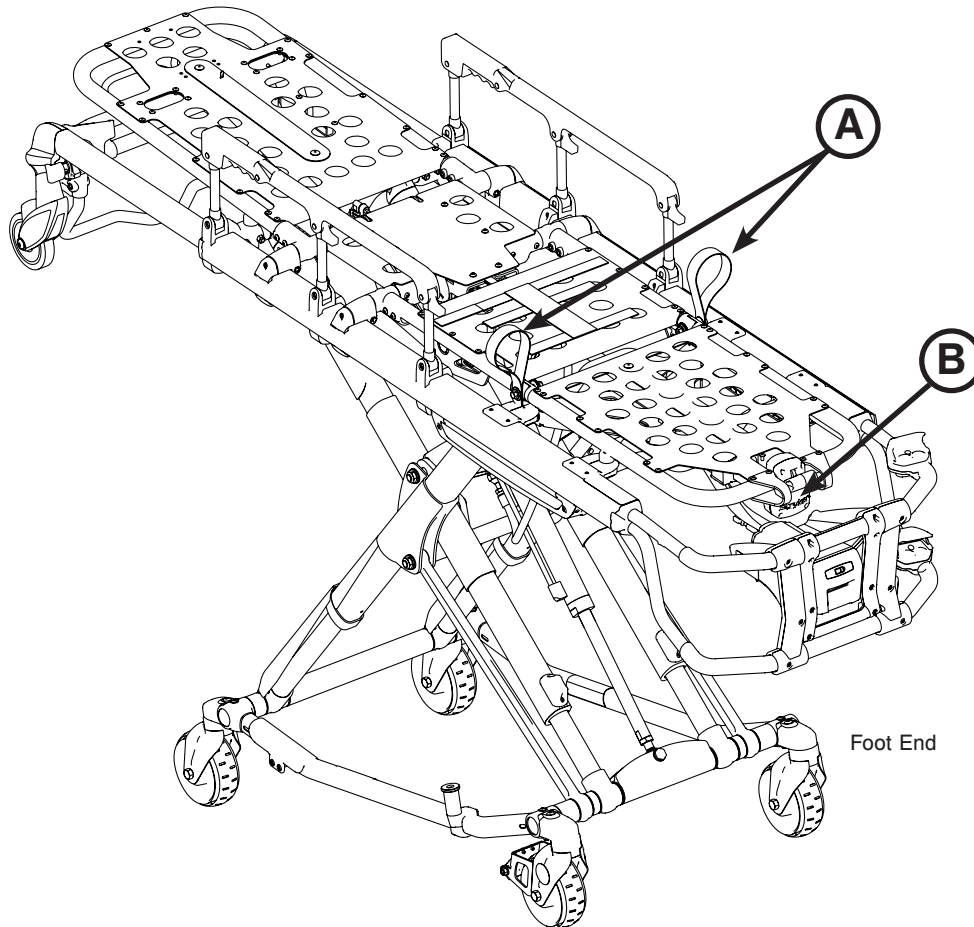

Figure 45: Gatch

Operation Guide

OPERATING THE OPTIONAL WHEEL LOCK(S)

To activate the optional wheel lock(s), press fully down on the pedal (A) as shown in Figure 46 until it stops and is resting firmly against the surface of the wheel.

To release the optional wheel lock(s), depress the upper face of the pedal with your foot or lift up with your toe under the pedal. The upper portion of the pedal will rest against the caster frame when the wheel lock is released.

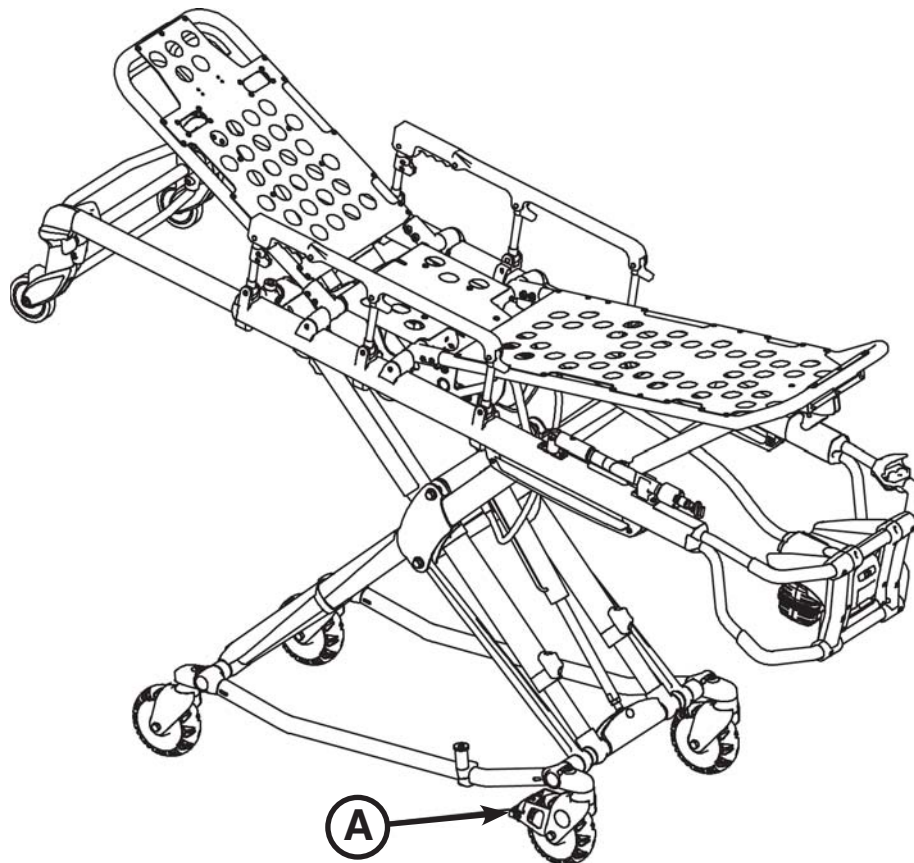

Figure 46: Wheel Lock

WARNING

- Never apply the optional wheel lock(s) while a patient is on the cot. Tipping could occur if the cot is moved while a wheel lock is applied, resulting in injury to the patient or operator and/or damage to the cot.
- Never leave a patient unattended on the cot or injury could result. Hold the cot securely while a patient is on the cot.
- Never install or use a wheel lock on a cot with excessively worn wheels. Installing or using a wheel lock on a wheel with less than a 6" diameter could compromise the holding ability of the wheel lock, possibly resulting in injury to the patient or operator and/or damage to the cot or other equipment.

CAUTION

Wheel lock(s) are only intended to help prevent the cot from rolling while unattended and to aid in patient transfer. A wheel lock may not provide sufficient resistance on all surfaces or under loads.

[Return To Table of Contents](#)

Operation Guide

OPERATING THE OPTIONAL 2-STAGE I.V. POLE

To use the 2-stage I.V. pole (see Figure 47.2):

1. Lift and pivot the pole from the storage position and push down until it is locked into the receptacle (A).
2. To raise the height of the pole, turn the lock actuator (B) counterclockwise and pull up on the telescoping portion (C) of the pole to raise it to the desired height.
3. Turn the lock actuator (B) clockwise to lock the telescoping portion in place.
4. Hang the I.V. bags on the I.V. hook (D).
5. Turn the lock actuator (B) counterclockwise and slide section (C) into the bottom tube.
6. Turn the lock actuator (B) clockwise to tighten.
7. Lift up and pivot the pole down into the storage position (see Figure 47.1).

CAUTION

To avoid damage to the I.V. pole, the weight of the I.V. bags or equipment must not exceed 40 pounds (18 kg).

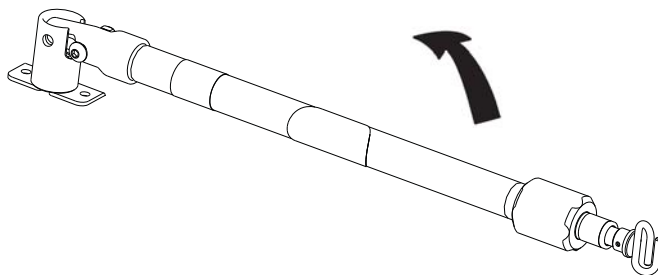

Figure 47.1: 2-Stage I.V. Pole Storage Position

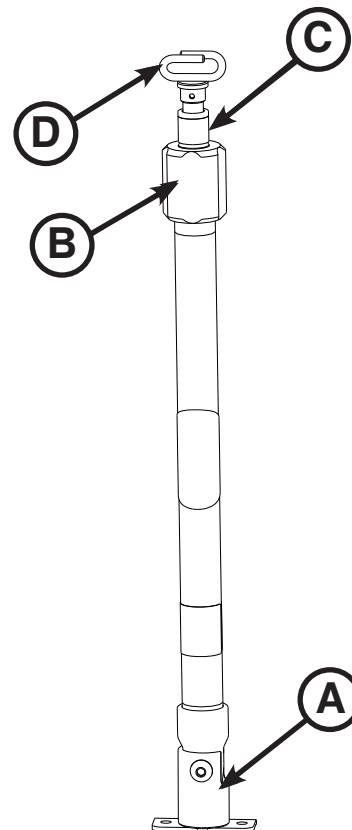

Figure 47.2: 2-Stage I.V. Pole

Operation Guide

OPERATING THE OPTIONAL 3-STAGE I.V. POLE

To use the 3-stage I.V. pole (see Figure 48.2):

1. Lift and pivot the pole from the storage position and push down until it is locked into the receptacle (A).
2. To raise the height of the pole, turn the lock actuator (B) counterclockwise and pull up on the bottom telescoping portion (C) of the pole to raise it to the desired height.
3. Turn the lock actuator (B) clockwise to lock the bottom telescoping portion in place.
4. For a higher I.V. pole, pull up on section (D) until the spring clip (E) engages.
5. Hang I.V. bags on the I.V. hook (F).
6. To lower the I.V. pole, push in on the spring clip (E) and slide section (D) down into section (C). Turn the lock actuator (B) counterclockwise and slide section (C) into the bottom tube.
7. Turn the lock actuator (B) clockwise to tighten.
8. Lift up and pivot the pole down into the storage position (see Figure 48.1).

CAUTION

To avoid damage to the I.V. pole, the weight of the I.V. bags or equipment must not exceed 40 pounds (18 kg).

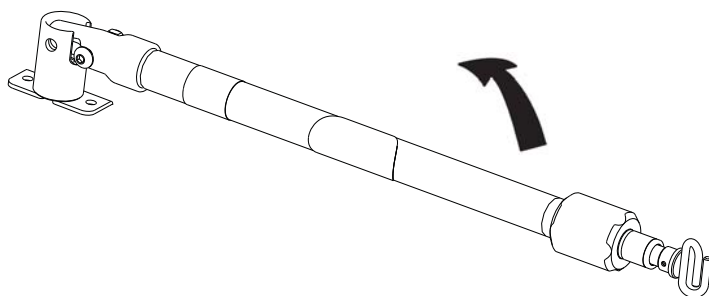

Figure 48.1: 3-Stage I.V. Pole Storage Position

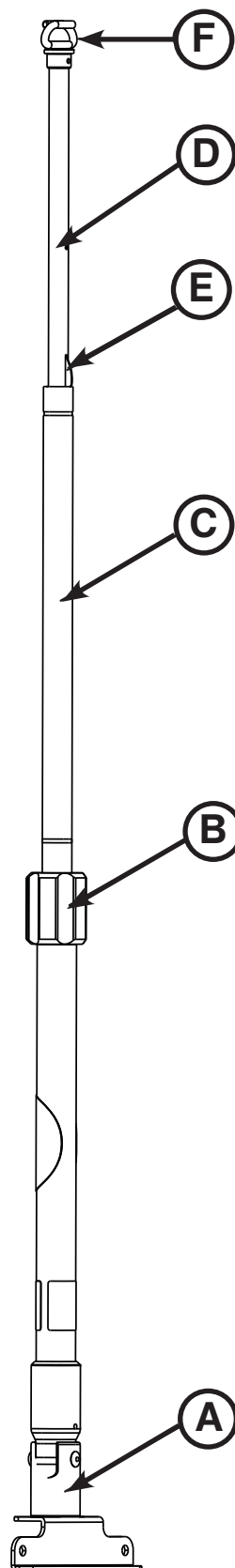

Figure 48.2: 3-Stage I.V. Pole

Optional Accessories

The accessories listed below can be purchased and installed on the Power-PRO XT cot.

Accessory	Part Number	Operation Guide Page Number
Equipment Hook	6500-147-000	57
Oxygen Bottle Holder, Removable	6080-140-000	58
Kickstand	6085-002-000	59
Pedi-Mate® Restraint Package	6091-300-010	60
Transfer Flat	6005-001-001	62
Pocketed Back Rest Pouch	6500-130-000	62
Head End Storage Flat	6500-128-000	63

Optional Accessories

USING THE EQUIPMENT HOOK

Use the equipment hook (A) (see Figure 49) to hang additional accessories or equipment, such as defibrillators or monitors.

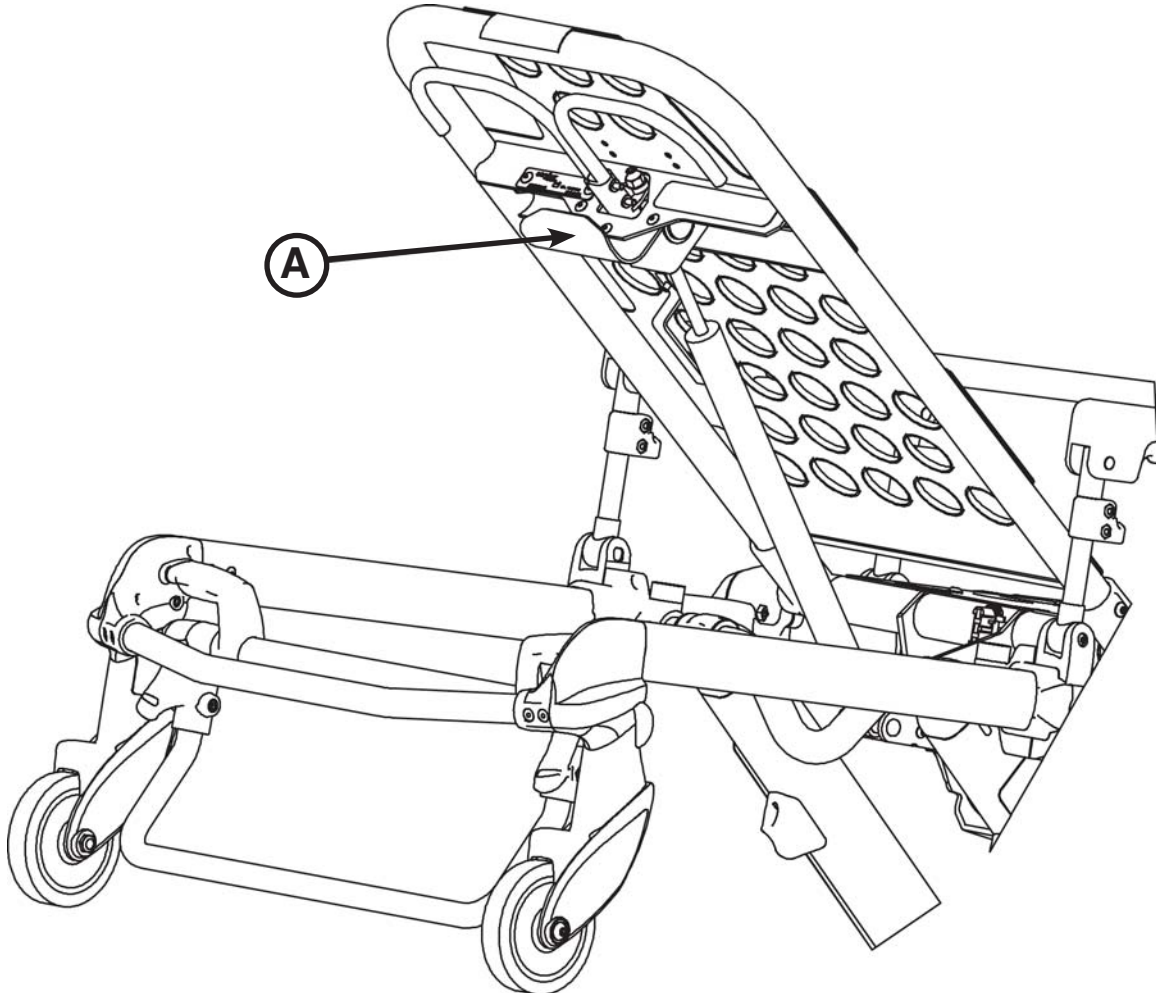

Figure 49: Equipment Hook

⚠ CAUTION

To avoid damage to the equipment hook, the weight of the accessories or equipment must not exceed 35 pounds (15.9 kg).

Optional Accessories

USING THE RETRACTABLE HEAD SECTION OXYGEN BOTTLE HOLDER

To attach an oxygen bottle to the retractable head section oxygen bottle holder:

1. Center the oxygen bottle on the cradled surface of item (A) as shown in Figure 50.
2. Tighten both straps (B) around the oxygen bottle.
3. Secure the slack on the straps to the Velcro® on the straps.

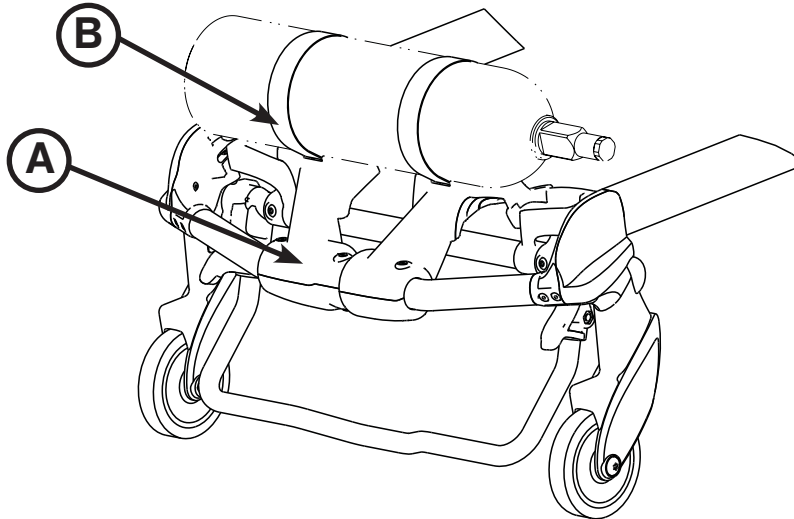

Figure 50: Retractable Head Section Oxygen Bottle Holder

Note: Inspect the straps and clips for wear between use and replace the strap if it is no longer holding the oxygen bottle.

⚠ WARNING

If the cot is equipped with the optional retractable head section oxygen bottle holder, use caution while the oxygen bottle holder is installed to avoid pinching your fingers between the fowler bracket and the oxygen bottle.

⚠ CAUTION

- To avoid damage to the retractable head section oxygen bottle holder (if equipped), the weight of the equipment must not exceed 40 pounds (18 kg).
 - Do not use two head end oxygen bottle holders at the same time.
-

Optional Accessories

USING THE KICKSTAND FOR DIALYSIS SCALE

The kickstand is intended for weighing patients on a scale.

Note:

- The kickstand assembly is configured for an X-frame cot retention system only.
- The kickstand (p/n 6085-002-000) is not compatible with the optional base storage net (p/n 6500-160-000).

WARNING

- Stryker recommends that a two person operation is used when using the kickstand.
- Make sure that the patient weight is centered on the cot before using the kickstand.
- Engage the kickstand with your foot only.
- Lower cot height prior to engaging kickstand for increased stability.
- Make sure that the kickstand remains in the retracted position and does not engage during transport.
- Do not use the kickstand as a brake.
- Do not engage kickstand on a sloped surface.

To use the kickstand:

1. Operator 1 engages the kickstand with their foot as shown in Figure 51.1.
2. Operator 2 lifts the foot end of the cot at a height sufficient to actuate the kickstand.
3. Both operators must make sure that the kickstand is in the forward locked position as shown in Figure 51.2.

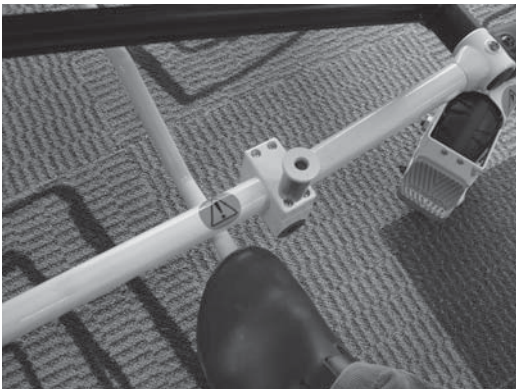

Figure 51.1



Figure 51.2

To release the kickstand:

1. Operator 1 lifts the foot end of the cot until both wheels are off of the floor.
2. Operator 2 rolls the cot slightly forward to make sure that the kickstand retracts on its own as shown in Figure 51.3.

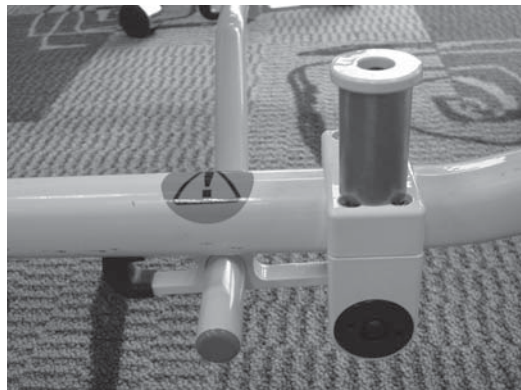

Figure 51.3

[Return To Table of Contents](#)

Optional Accessories

ATTACHING THE PEDI-MATE® INFANT RESTRAINT SYSTEM

See the Pedi-Mate® users manual for the manufacturer's recommendations for the use, operation and care of the Pedi-Mate® Infant Restraint System.

To secure the Pedi-Mate® to the cot:

1. Remove any restraints that are already attached to the cot.
2. Raise the cot backrest to the full upright position.
3. Position the Pedi-Mate® pad flat on the backrest with the black backrest straps out (see Figure 52.1).



Figure 52.1: Positioning the Pedi-Mate®

4. Wrap the straps around the backrest and insert the ends of the straps through the brackets. Securely fasten the buckle (see Figure 52.2).

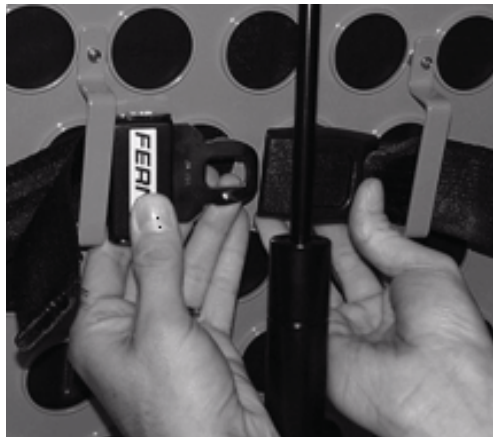

Figure 52.2: Fastening the Pedi-Mate® Buckle

WARNING

To avoid accidental release of the Pedi-Mate®, and possible injury to the infant, ensure that the buckle is located away from obstructions on the cot or accessories.

Optional Accessories

ATTACHING THE PEDI-MATE® INFANT RESTRAINT SYSTEM (CONTINUED)

5. Pull firmly on the end of the adjustable backrest strap and tighten it securely.
6. Insert the mainframe straps between the cot frame and the mattress. To ensure that the release button is located toward the foot end of the cot, insert the buckle behind the litter cross brace and bring it up in front of the cross brace. Secure the buckle around the cross brace, leaving a little slack in the strap for final adjustment (see Figure 52.3).



Figure 52.3: Securing the Safety Restraints on a Cot

WARNING

To avoid accidental release of the Pedi-Mate®, and possible injury to the infant, ensure that the buckle is located away from obstructions on the cot or accessories.

7. Verify that all of the straps are snug and fastened securely (see Figure 52.4).



Figure 52.4: Pedi-Mate® Strapped to a Cot

Note: These are general instructions for installation of the Pedi-Mate®. Safe and proper use of the Pedi-Mate® is solely at the discretion of the user. Stryker recommends that all users be trained on the proper use of the Pedi-Mate® before using it in an actual situation. Retain these instructions for future reference. Include them with the product in the event of transfer to new users.

Pedi-Mate® is a registered trademark of Ferno-Washington, Inc.

[Return To Table of Contents](#)

Optional Accessories

USING THE TRANSFER FLAT

When transferring larger patients, use of the Transfer Flat is recommended.

INSTALLING THE BACKREST STORAGE POUCH

Install the optional backrest storage pouch using the Velcro® straps as shown in Figure 53. Insert each strap through a hole in the backrest skin and mount the pouch flat against the backrest.

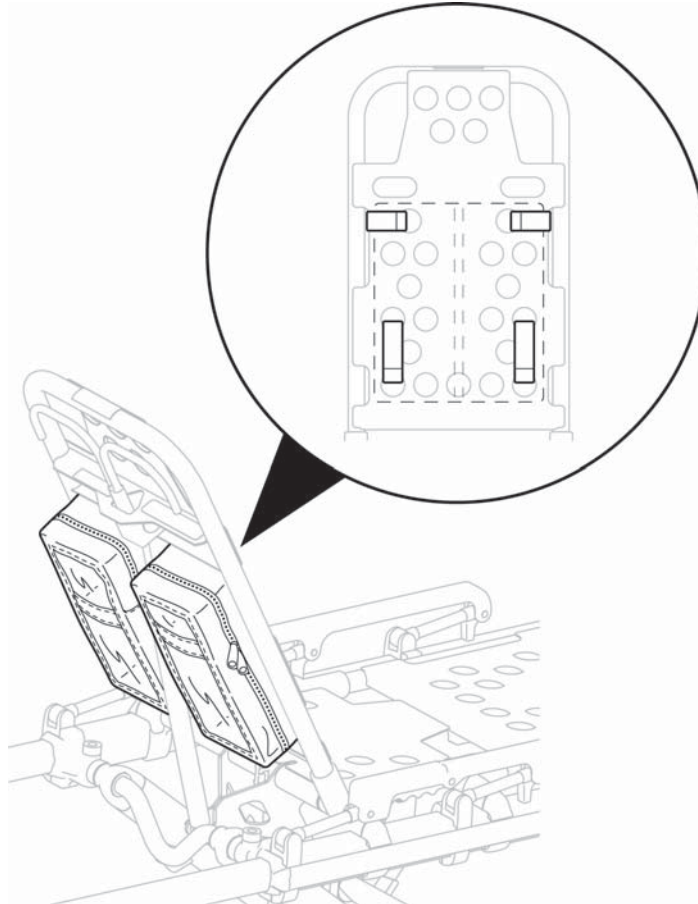

Figure 53: Backrest Storage Pouch

CAUTION

- Do not store items under the cot mattress. Storing items under the mattress can interfere with the operation of the cot.
 - The weight of the equipment in the pocketed backrest storage pouch (if equipped) must not exceed 20 pounds (9 kg).
-

Optional Accessories

INSTALLING THE HEAD END STORAGE FLAT

To install the optional head end storage flat (see Figure 54):

1. Install the Velcro® straps (A) near the pneumatic cylinder and around the cross bar of the retractable head section.
2. Buckle the restraint straps (B) around the outer rails of the retractable head section.

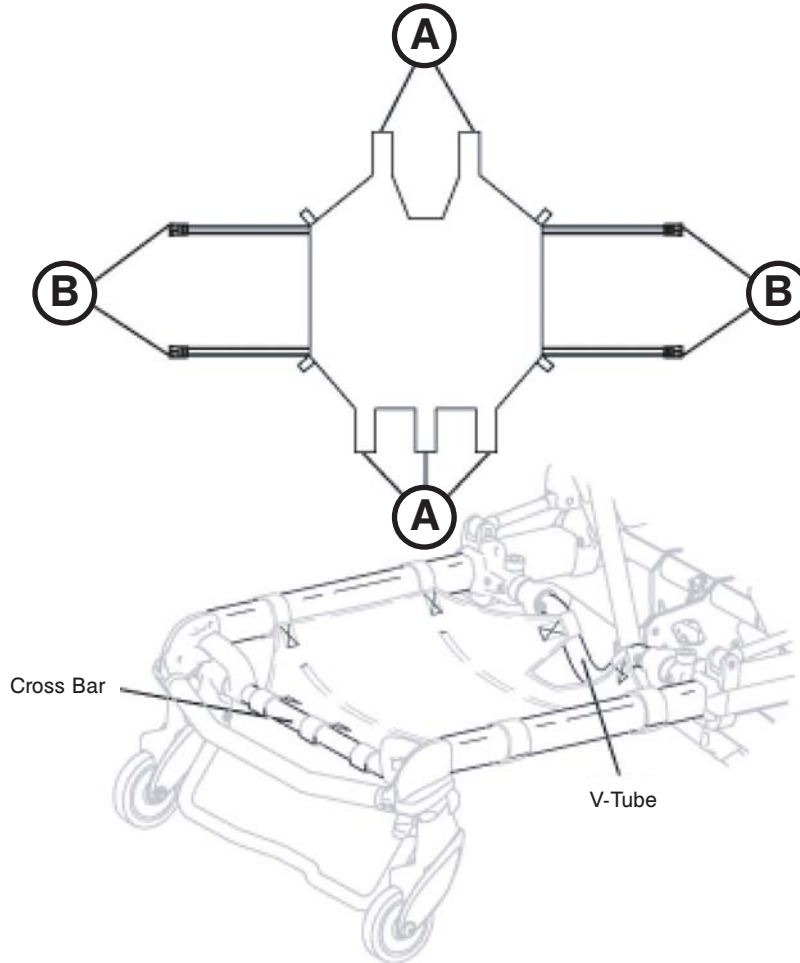

Figure 54: Head End Storage Flat

WARNING

When the optional head end storage flat is being used, ensure that it does not interfere with the operation of the retractable head section, safety bar and safety hook. Injury to the patient or operator could result.

CAUTION

- Do not store items under the cot mattress. Storing items under the mattress can interfere with the operation of the cot.
- The weight of the equipment in the head end storage flat (if equipped) must not exceed 40 pounds (18 kg).

[Return To Table of Contents](#)

Optional Accessories

INSTALLING THE BASE STORAGE NET

To install the base storage net, wrap the Velcro straps around the base tubes.

CAUTION

- The weight of the equipment in the base storage net (if equipped) must not exceed 20 pounds (9 kg).
- Be careful when retracting the base to avoid damaging items stored in the base storage net.

Note: The kickstand (p/n 6085-002-000) is not compatible with the optional base storage net (p/n 6500-160-000).

Cleaning

The Power-PRO™ XT cot is designed to be power washable. The unit may show some signs of oxidation or discoloration from continuous washing, however, no degradation of the cot's performance characteristics or functionality will occur due to power washing as long as the proper procedures are followed.

Thoroughly clean the cot once a month. Clean Velcro® AFTER EACH USE. Saturate Velcro® with disinfectant and allow disinfectant to evaporate. (Appropriate disinfectant for nylon Velcro® should be determined by the service.)

WASHING PROCEDURE

- **Always remove the battery!** Never wash the cot with the battery installed.
- Follow the cleaning solution manufacturer's dilution recommendations exactly.
- The preferred method Stryker Medical recommends for power washing the cot is with the standard hospital surgical cart washer or hand held wand unit.

WASHING LIMITATIONS

WARNING

Use any appropriate personal safety equipment (goggles, respirator, etc.) to avoid the risk of inhaling contagion. Use of power washing equipment can aerate contamination collected during the use of the cot.

CAUTION

- DO NOT STEAM CLEAN OR ULTRASONICALLY CLEAN THE UNIT.
 - Maximum water temperature should not exceed 180°F/82°C.
 - Maximum air dry temperature (cart washers) should not exceed 240°F/115°C.
 - Maximum water pressure should not exceed 1500 psi/130.5 bar. If a hand held wand is being used to wash the unit, the pressure nozzle must be kept a minimum of 24 inches (61 cm) from the unit.
 - Towel dry all casters and interface points.
 - Failure to comply with these instructions may invalidate any/all warranties.
 - Always remove the battery before washing the cot.
-

Cleaning

In general, when used in those concentrations recommended by the manufacturer, either phenolic type or quaternary (excluding Virex® TB) type disinfectants can be used. Iodophor type disinfectants are not recommended for use because staining may result.

Suggested cleaners for the cot surfaces:

- Quaternary Cleaners (active ingredient - ammonium chloride)
- Phenolic Cleaners (active ingredient - o-phenylphenol)
- Chlorinated Bleach Solution (5.25% - less than 1 part bleach to 100 parts water)

Avoid over saturation and ensure that the product does not stay wet longer than the chemical manufacturer's guidelines for proper disinfecting.

WARNING

SOME CLEANING PRODUCTS ARE CORROSIVE IN NATURE AND MAY CAUSE DAMAGE TO THE PRODUCT IF USED IMPROPERLY. If the products described above are used to clean Stryker EMS equipment, measures must be taken to insure the cots are wiped with clean water and thoroughly dried following cleaning. Failure to properly rinse and dry the cots will leave a corrosive residue on the surface of the cots, possibly causing premature corrosion of critical components.

Note: Failure to follow the above directions when using these types of cleaners may void this product's warranty (see [page 91](#)).

REMOVAL OF IODINE COMPOUNDS

Use a solution of 1/2 Tablespoon Sodium Thiosulfate in a pint of warm water to clean the stained area. Clean as soon as possible after staining occurs. If stains are not immediately removed, allow solution to soak or stand on the surface. Rinse surfaces which have been exposed to the solution in clear water before returning unit to service.

WARNING

Failure to properly clean or dispose of contaminated mattress or cot components will increase the risk of exposure to bloodborne pathogens and may cause injury to the patient or the operator.

Preventative Maintenance

Preventative maintenance should be performed at a minimum of annually. A preventative maintenance program should be established for all Stryker Medical equipment. Preventative maintenance may need to be performed more frequently based on the usage level of the product. The cot requires regular maintenance. Establish and follow a maintenance schedule and keep records of maintenance activity (see [page 71](#) for a form).

CAUTION

A preventative maintenance program should be established for all Stryker EMS equipment. Preventative maintenance may need to be performed more frequently based on the usage level of the product. Close attention should be given to safety features including, but not limited to:

- Hydraulic power mechanism
- All electrical controls return to off or neutral position when released

For additional maintenance information, see the preventative maintenance information on [page 71](#).

WARNING

- Do not modify the cot or any components of the cot. Modifying the product can cause unpredictable operation resulting in injury to the patient or operator. Modifying the product will also void its warranty (see [page 91](#)).
 - Escaping fluid under pressure can penetrate the skin causing serious injury. Avoid the hazard by relieving pressure before disconnecting hydraulic or other lines. Tighten all connections before applying pressure. If an accident occurs, see a doctor immediately. Any fluid injected into the skin must be surgically removed within a few hours or gangrene may result. Doctors unfamiliar with this type of injury should reference a knowledgeable medical source.
 - To avoid the risk of injury, do not use bare hands to check for hydraulic leaks.
-

When using maintenance products, follow the directions of the manufacturer and reference all material safety data sheets.

CAUTION

- Improper maintenance can cause injury or damage to the product. Maintain the cot as described in this manual. Use only Stryker approved parts and maintenance procedures. Using unapproved parts and procedures could cause unpredictable operation and/or injury and will void the product warranty (see [page 91](#)).
 - Failure to use authorized parts, lubricants, etc. could cause damage to the cot and will void the warranty of the product.
 - Hydraulic lines, hoses, and connections can fail or loosen due to physical damage, kinks, age, and exposure. Check hoses and lines regularly to avoid damage to the cot. Check and tighten loose connections.
 - Do not tip the cot onto its load wheels and actuate the product as this will allow air to enter the hydraulic system.
-

LUBRICATION

The cot has been designed to operate without the need for lubrication.

CAUTION

Do not lubricate the bearings in the X-frame as it will degrade the performance of the cot and may void its warranty (see [page 91](#)).

You can apply Tri-Flow[®] lubrication to the optional kickstand during periodic maintenance (see [page 68](#)).

Preventative Maintenance

REGULAR INSPECTION AND ADJUSTMENTS

Maintenance Intervals

The following schedule is intended as a general guide to maintenance. Bear in mind that such factors as weather, terrain, geographical location, and individual usage will alter the required maintenance schedule. If you are unsure as to how to perform these checks please contact your Stryker service technician. If you are in doubt as to what intervals to follow in maintaining your product, consult your Stryker service technician. Use the hour meter (see [page 45](#)) to determine the frequency for preventative maintenance procedures.

Item	Routine	Every (whichever comes first)			
		1 Month or 2 hours	3 Months or 6 hours	6 Months or 12 hours	12 Months or 24 hours
Settings	Verify the in-fastener shut-off is configured properly	X			
	Verify the cot and fastener fit and function properly				X
	Verify the safety bar engages the vehicle safety hook properly				X
Cylinder	All fasteners are secure (reference all assembly drawings)		X		
	Verify the cylinder is adjusted so the lock nut is tight and the cot stops moving when it hits the dead stops				X
	Inspect for and verify that there are no hydraulic fluid (red) leaks; inspect the fittings and tighten as necessary		X		
	Extend cylinder rod completely and wipe down rod with soft cloth and household cleaner	X			
Hydraulics	Inspect motor mount and verify that all fasteners are secure		X		
	Verify that there are no hydraulic fluid leaks		X		
	Inspect the reservoir and verify that there are no leaks		X		
	Inspect hoses and fittings for damage or wear; replace as necessary			X	
	Verify the hydraulic velocity fuse - Place a weight of approximately 50 pounds on the cot, raise the cot, lift the cot with two operators, pull the manual back-up release handle, rapidly set the cot down, verify that the cot does not drop				X
Electronic Controls	Extend cot to raised position, measure and check load height			X	
	Verify "jog" function is operating			X	
	Verify high speed retract is working			X	
Switches	Verify there is no damage or wear to either switch			X	
	Verify both switches operate correctly - Replace if necessary			X	
Cables/Wires	Verify there is no damage or pinching of wiring harness, cables or lines		X		
	Check routing(s) and connection(s), verify there are no hanging wires	X			
	Verify there are no damaged connectors, replace if necessary		X		

Preventative Maintenance

Item	Routine	Every (whichever comes first)			
		1 Month or 2 hours	3 Months or 6 hours	6 Months or 12 hours	12 Months or 24 hours
Manual Back-up Release Handle	Verify that the manual back-up release handle functions properly	X			
	Verify the manual back-up release handle returns to the stowed position				X
	Verify the base extends/retracts smoothly when the manual back-up release handle is engaged		X		
	With 100 pounds or more on the cot, verify the cot does not lower when the manual backup release handle is pulled		X		
	Inspect the cot frame/litter	X			
Litter	Verify all welds intact, not cracked or broken				X
	Verify no bent, broken or damaged components			X	
	Verify all fasteners secure (reference all assembly drawings)		X		
	Verify warning labels present, legible (reference assembly drawings)				X
	Verify no damage or tears on cot grips			X	
	Verify the siderails operate and latch properly			X	
	Verify the backrest cylinder operates properly		X		
	Adjust pneumatic cylinder for full range of motion, if required		X		
	Verify the footrest operates properly			X	
	Verify no cracks or tears on cot mattress			X	
Mattress					
Restraints	Inspect patient restraints for proper function and no excessive wear	X			
Base	Inspect the cot frame/base	X			
	Verify all welds intact, not cracked or broken				X
	Verify no bent, broken, or damaged components			X	
	Verify all fasteners secure		X		
Wheels	Verify no excessive damage to X-frame guards, replace if necessary			X	
	Verify wheels are free of debris			X	
	Verify tires in good condition				X
	Verify all wheels secure, rolling and swiveling properly	X			
	Check and adjust optional wheel locks as necessary				X

[Return To Table of Contents](#)

Preventative Maintenance

Item	Routine	Every (whichever comes first)			
		1 Month or 2 hours	3 Months or 6 hours	6 Months or 12 hours	12 Months or 24 hours
X-Frame Head Section	Verify smooth operation of X-frame		X		
	Verify all fasteners secure		X		
	Verify no bent, broken, or damaged components			X	
	Verify the head section extends and locks properly		X		
	Verify the grip bar has no excessive damage or tears			X	
	Verify load wheels are secure and roll properly			X	
	Verify the safety bar operates properly	X			
Accessories	Inspect the straps and clips on the retractable head section oxygen bottle holder (optional) for wear				X
	Verify the I.V. pole (optional) operates properly		X		
	Verify the head extension & pillow (optional) operates properly		X		
	Verify the restraint extender (optional) operates properly		X		
	Verify the kickstand (optional) retracts fully to the transport position		X		
	Verify that the kickstand (optional) bolts are tightened properly		X		
	Lubricate the kickstand spring and internal spring housing (optional) using Tri-Flow® lubrication			X	

Maintenance Record

Date	Maintenance Operation Performed	By	Hours

[Return To Table of Contents](#)

Training Record

Trainee Name	Training Date		Training Method Owner's Manual, In-Service, Formal Class, Etc.
	Basic Training	Refresher Update	

Troubleshooting Guide

ELECTRONICS AND HYDRAULICS LOCATOR

Note: Some components have been removed for clarity.

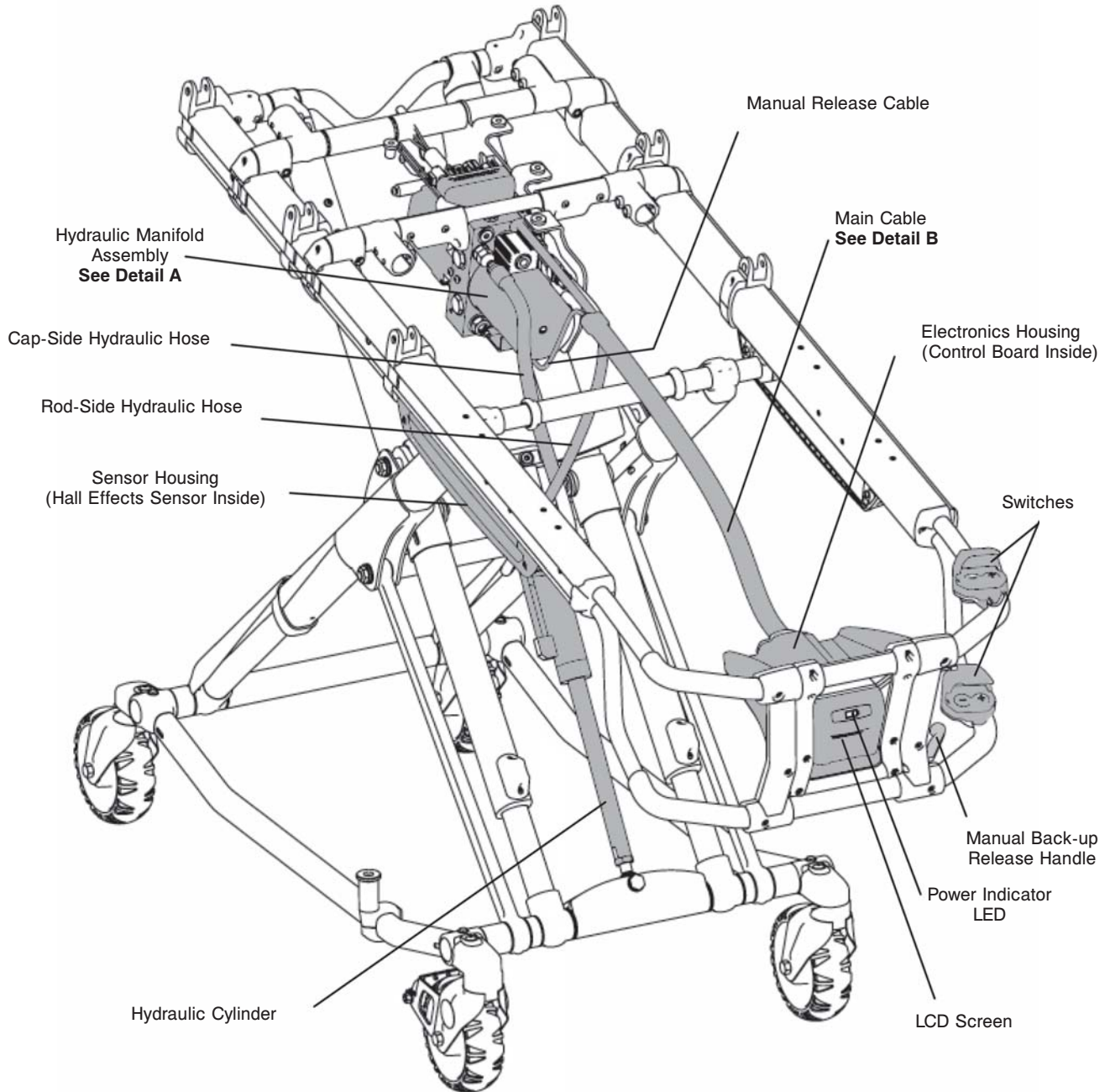

[Return To Table of Contents](#)

Troubleshooting Guide

HYDRAULIC MANIFOLD COMPONENTS LOCATOR

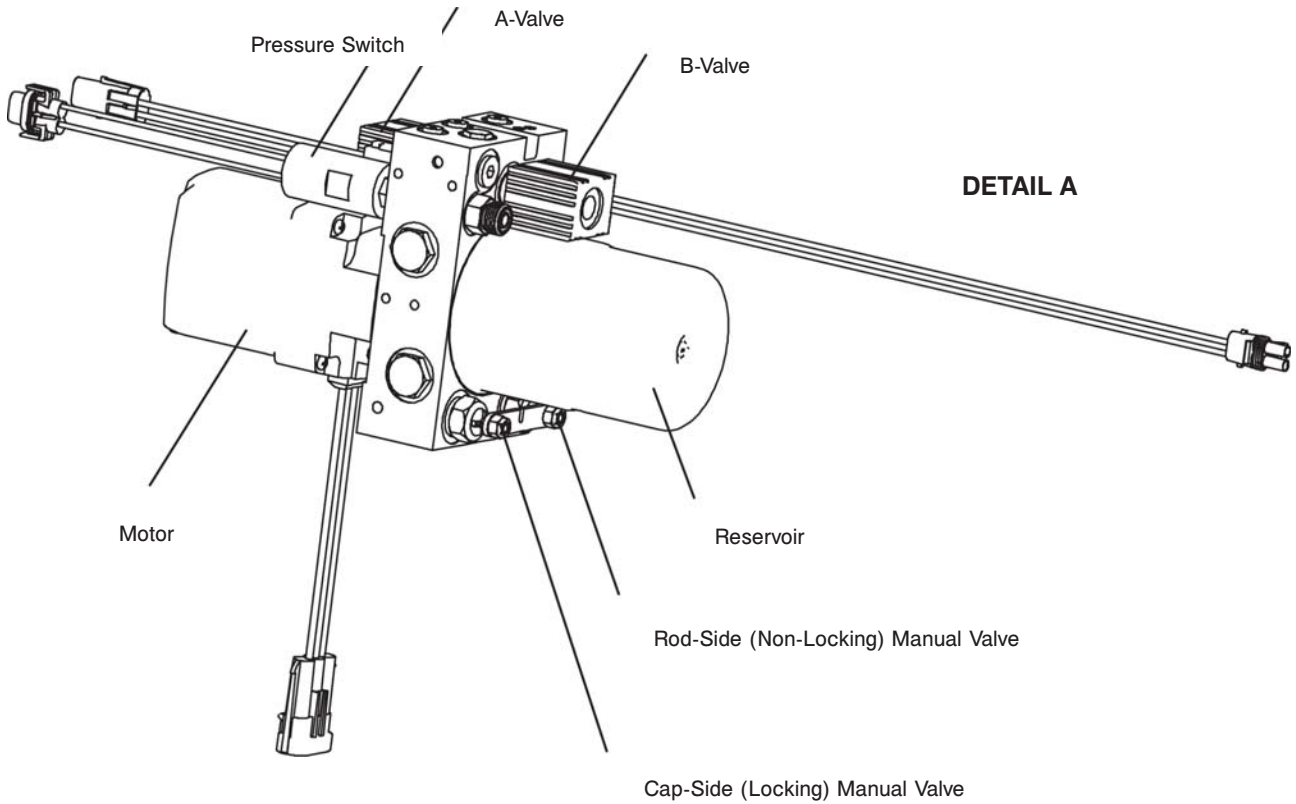

DETAIL B

Wiring Schematics
Main Cable 8-Pin Connector

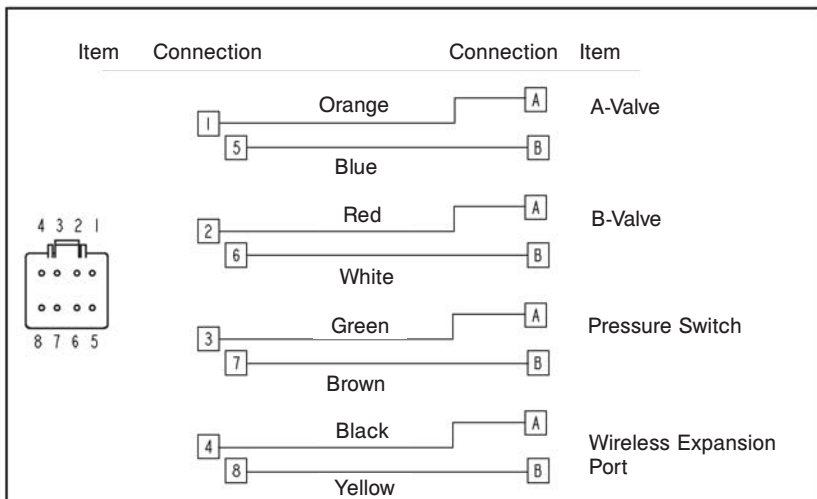

Troubleshooting Guide

ELECTRICAL SYSTEM BLOCK DIAGRAM

Lift and Extend (Unload) Functions

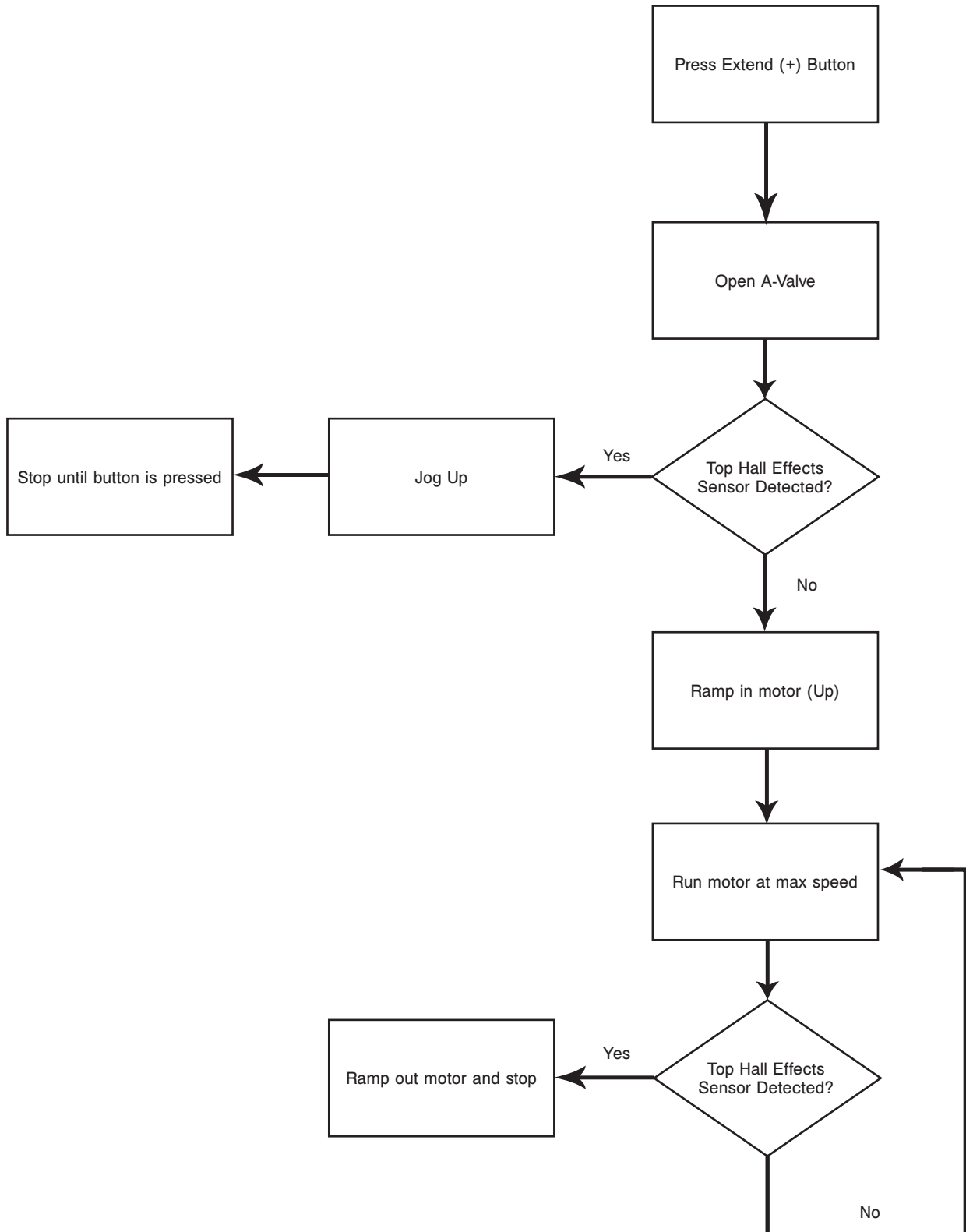

[Return To Table of Contents](#)

Troubleshooting Guide

Electrical System Block Diagram

Lower and Retract (Load) Functions

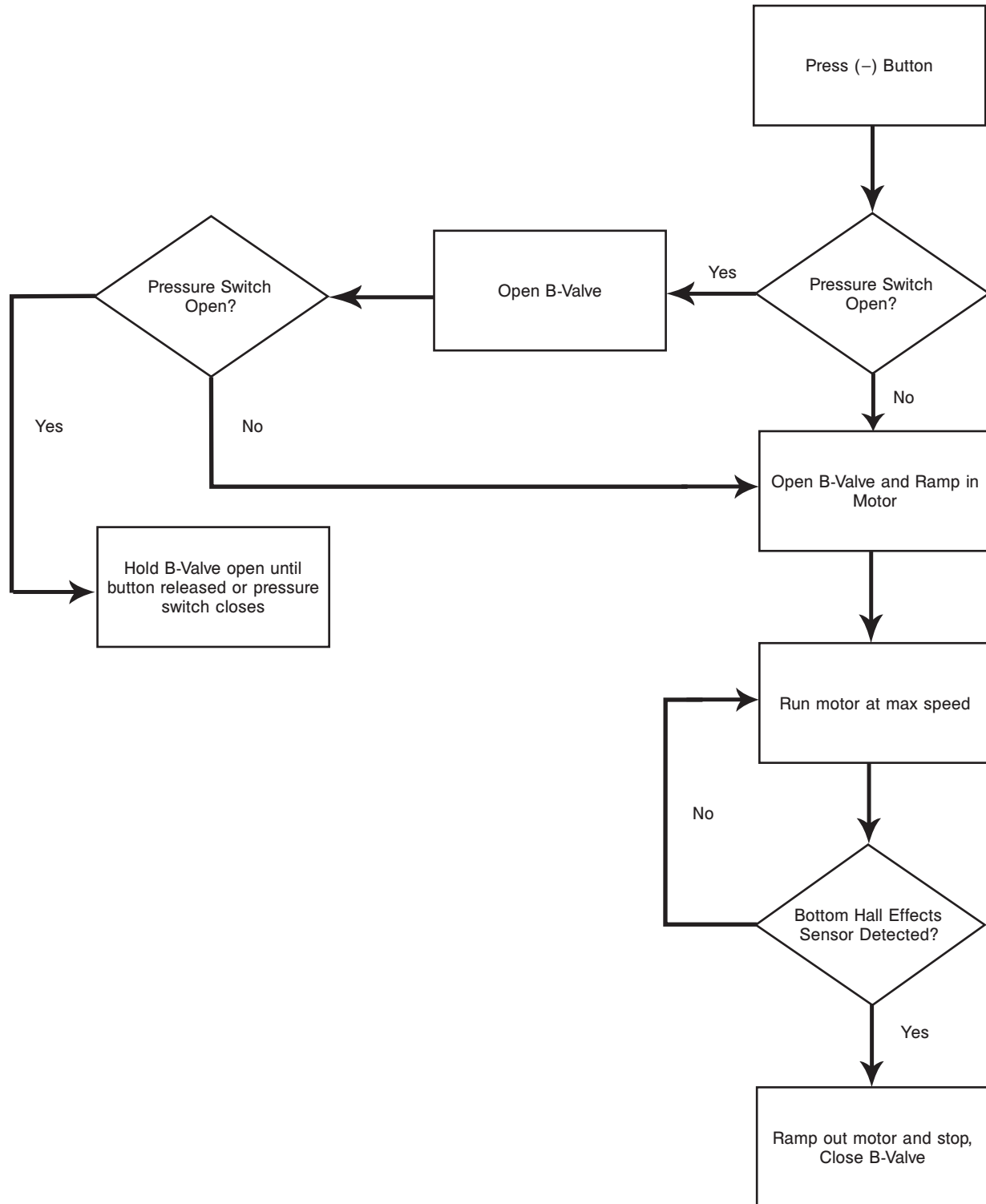

Troubleshooting Guide

TROUBLESHOOTING GUIDE

Check for proper operation after each step. When the problem is fixed, return the cot to service. If assistance is needed at any time during troubleshooting, please contact a service technician at (800) 327-0770 or (269) 324-6500.

PROBLEM	SOLUTION	PAGE(S)
Litter drifts (without patient weight).	<ol style="list-style-type: none"> 1. Flush the hydraulic system by squeezing the manual release handle while simultaneously pressing the (+) power button for approximately 15 seconds. Repeat if necessary. 2. Check manual release cable adjustment. 3. Change 'locking' manual valve. 4. Change 'B' valve. 	
Base drifts (without patient weight).	<ol style="list-style-type: none"> 1. Flush the hydraulic system by squeezing the manual release handle while simultaneously pressing the (+) power button for approximately 15 seconds. Repeat if necessary. 2. Check manual release cable adjustment. 3. Change 'non-locking' manual valve. 4. Change 'A' valve. 	
Litter does not lower in the powered mode.	<ol style="list-style-type: none"> 1. Check power indicator LED. <ol style="list-style-type: none"> A. If blinking constant RED, change battery. B. If blinking a patterned RED short, short, long flash: <ol style="list-style-type: none"> i. Check for broken or disconnected wires. ii. Check for 24 VDC at connector (C) on the main cable by the motor while pressing the retract (-) button. If voltage is present, replace (in order) the hall effects sensor, solenoid, and or 'B' valve. If voltage is not present, go to step iii. iii. Check for 24 VDC on electronics assembly pins 1 blue and 5 orange on (F) while pressing the retract (-) button. If voltage is not present, replace the electronics assembly. If voltage is present, replace the wire harness. C. If the GREEN light turns on, but does not lower, try the other switch. If the other switch works, replace the bad switch. 	80, 81

Troubleshooting Guide

TROUBLESHOOTING GUIDE (CONTINUED)

PROBLEM	SOLUTION	PAGE(S)
<p>Litter does not extend in the powered mode.</p>	<ol style="list-style-type: none"> 1. Check power indicator LED. <ol style="list-style-type: none"> A. If blinking constant RED, change battery. B. If blinking a patterned RED short, short, long flash: <ol style="list-style-type: none"> i. Check for broken or disconnected wires. ii. Check for 24 VDC at connector (B) on the main cable by the motor while pressing the extend (+) button. If voltage is present, replace (in order) the hall effects sensor, solenoid, and or 'A' valve. If voltage is not present, go to step iii. iii. Check for 24 VDC on electronics assembly pins 2 white and 6 red on (F) while pressing the extend (+) button. If voltage is not present, replace the electronics assembly. If voltage is present, replace the wire harness. C. If the GREEN light turns on, but does not lower, try the other switch. If the other switch works, replace the bad switch. 2. Check motor. <ol style="list-style-type: none"> A. If the motor runs, but does not raise the cot: <ol style="list-style-type: none"> i. Check the manual release cable for too much tension. ii. Lightly tap the manual locking valve. iii. Replace the manual locking valve. B. If the motor is stalled, replace the 'A' valve. C. If the light is GREEN, but the motor does not run <ol style="list-style-type: none"> i. Check for 24 VDC at connector (E) on the main cable. If voltage is present, replace the hall effects sensor. If the hall effects sensor is replaced, and the motor still does not run, replace the hydraulic sub assembly. If voltage is not present, go to step ii. ii. Check for 24 VDC on electronics assembly connection (H) (-) lead on black (+) lead on green while pressing the extend (+) button. If voltage is not present, replace the electronics assembly. If voltage is present, replace the main cable. 	<p>80, 81</p>

Troubleshooting Guide

TROUBLESHOOTING GUIDE (CONTINUED)

PROBLEM	SOLUTION	PAGE(S)
Base does not retract in the powered mode.	<ol style="list-style-type: none"> 1. Check power indicator LED. <ol style="list-style-type: none"> A. If blinking constant RED, change battery. B. If blinking a patterned RED short, short, long flash: <ol style="list-style-type: none"> i. Check for broken or disconnected wires. ii. Check for 24 VDC at connector (B) on the main cable by the motor while pressing the extend (+) button. If voltage is present, replace (in order) the hall effects sensor, solenoid, and or 'A' valve. If voltage is not present, go to step iii. iii. Check for 24 VDC on electronics assembly pins 2 white and 6 red on (F) while pressing the (+a) button. If voltage is not present, replace the electronics assembly. If voltage is present, replace the wire harness. 	80, 81
Base does not extend in the manual mode.	<ol style="list-style-type: none"> 1. Check manual cable adjustment. 2. Change 'non-locking' manual valve. 	
Base does not retract in the manual mode.	<ol style="list-style-type: none"> 1. Check manual release cable adjustment. 2. Change 'locking' manual valve. 	
Litter does not retract in the manual mode (with patient weight).	<ol style="list-style-type: none"> 1. Make sure that the weight is off of the casters before lowering the cot. 2. Check manual cable adjustment. 3. Replace 'locking' manual valve. 	
Litter does not extend in the manual mode.	<ol style="list-style-type: none"> 1. Check manual cable adjustment. 2. Change 'non-locking' manual valve. 	
High Speed retract does not engage.	<ol style="list-style-type: none"> 1. Check that weight is off of the casters. 2. Change pressure switch. 3. Change hall effect cable. 	

Troubleshooting Guide

MAIN CABLE ASSEMBLY

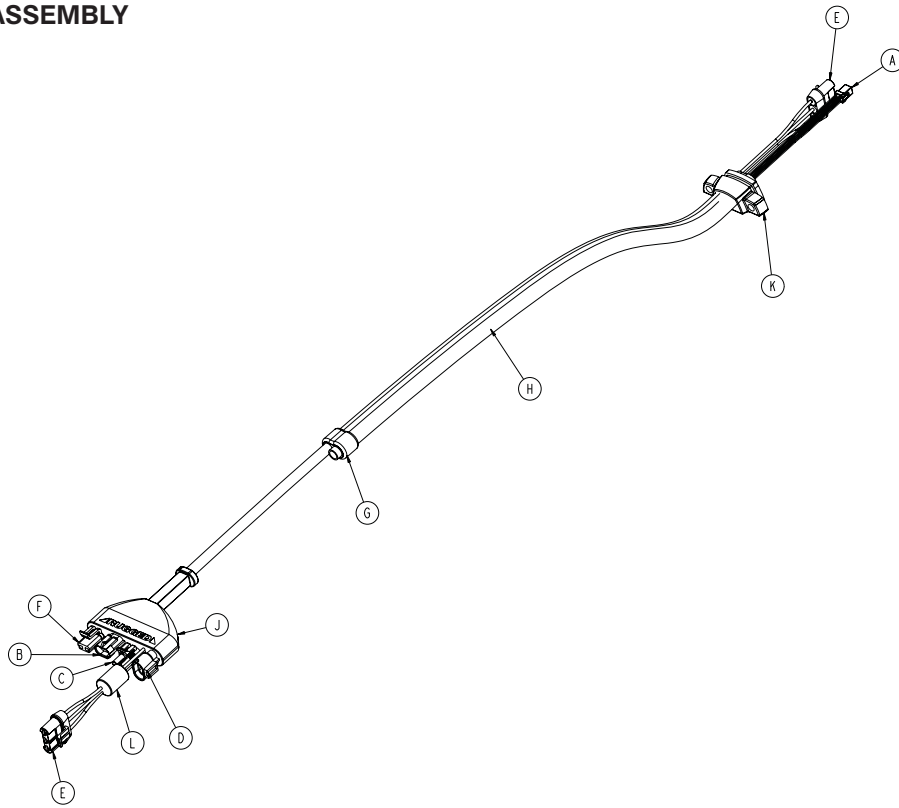

ELECTRONICS ASSEMBLY

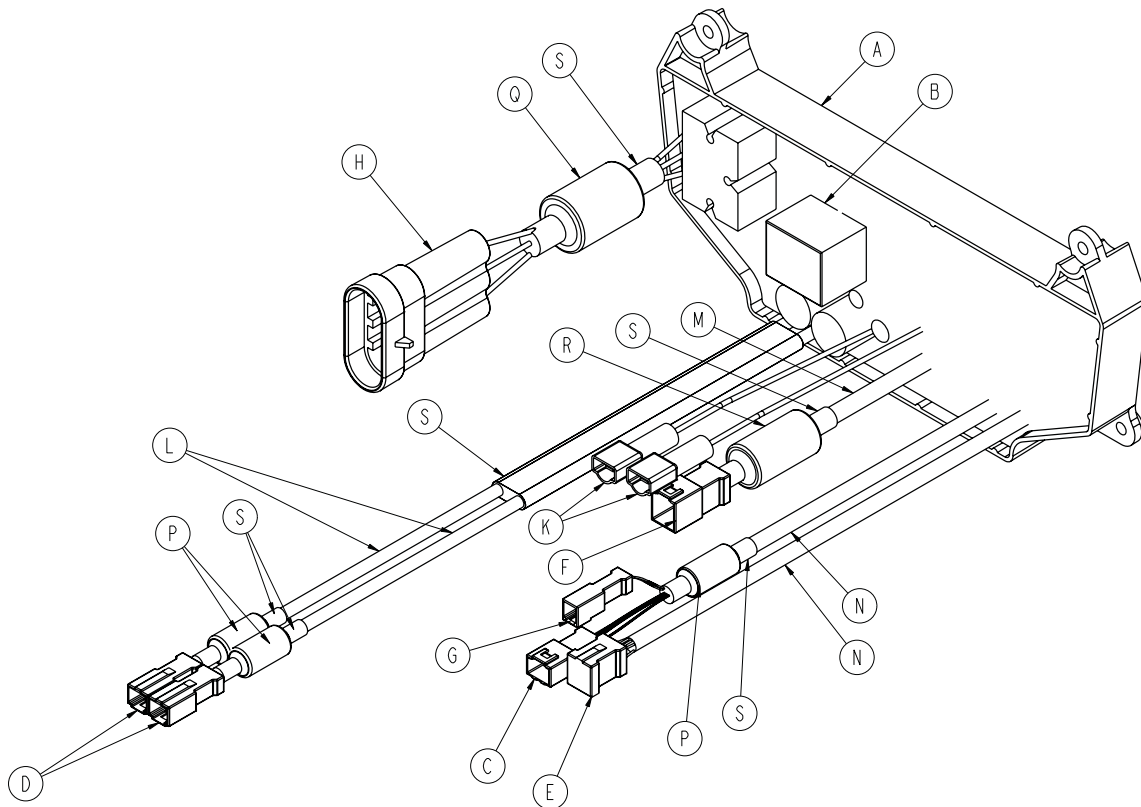

Troubleshooting Guide

ELECTRONICS ASSEMBLY WIRING SCHEMATICS

ITEM	CONNECTION	CONNECTION	ITEM
------	------------	------------	------

HYDRAULICS - 22 AWG

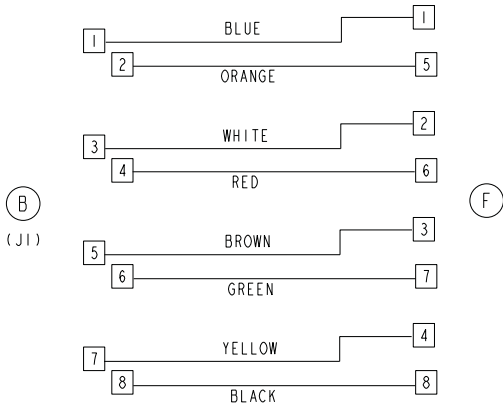

SWITCH - 22 AWG



ITEM	CONNECTION	CONNECTION	ITEM
------	------------	------------	------

HAND HELD PROGRAMMER - 22 AWG

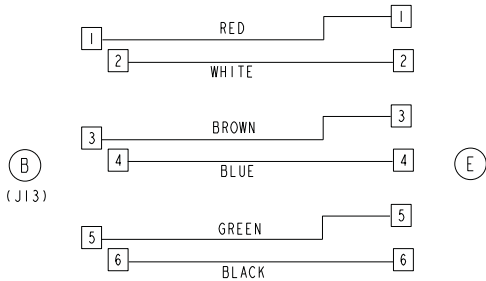

HALL-EFFECT SENSOR - 22 AWG

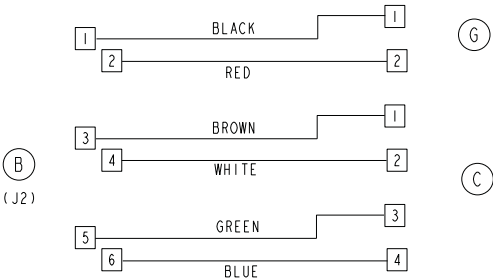

ITEM	CONNECTION	CONNECTION	ITEM
------	------------	------------	------

MOTOR CABLE - 14 AWG



BATTERY POSITIVE - 14 AWG



BATTERY NEGATIVE - 14 AWG

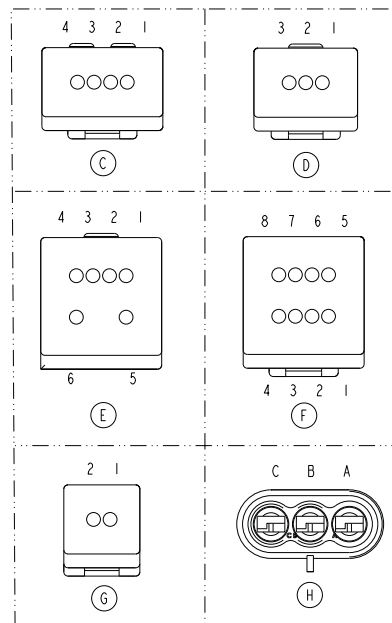

[Return To Table of Contents](#)

Quick Reference Replacement Parts List

The parts and accessories listed on these pages are all currently available for purchase. Some of the parts identified on the assembly drawing parts in this manual may not be individually available for purchase. Please call Stryker Customer Service USA: 1-800-327-0770 (Option 2) for availability and pricing.

Part Name	Part Number
Backrest Pouch Option	6500-130-000
Base Storage Flat	6500-160-000
Cable, Hall Effect Sensor	6500-001-160
Cylinder	6500-001-213
Defibrillator Tray Option	6500-170-000
Electronics Assembly	6500-001-014
Equipment Hook Option	6500-147-000
Equipment Hook	6500-700-003
Gas Cylinder, Fowler	1010-031-077
Head Extension Kit	6100-700-012
Head Extension Pillow Only Option	6100-045-000
Head Section Assembly	6085-001-037
Hydraulic Oil	6500-001-293
In-Fastener Shut-Off Assembly	6500-001-027
I.V. Pole, 2-Stage, Right	6500-210-000
I.V. Pole, 2-Stage, Left	6500-211-000
I.V. Pole, 2-Stage, Dual	6500-212-000
I.V. Pole, 3-Stage, Right	6500-215-000
I.V. Pole, 3-Stage, Left	6500-216-000
I.V. Pole, 3-Stage, Dual	6500-217-000
Kit, Base Tube Protector	6500-700-015
Kit, Battery Pack, SMRT Pak	6500-700-046
Kit, SMRT Power System 12 VDC (Car Charger), includes charger, 2 paks, and power cord	6500-700-040
Kit, SMRT Power System 120 Vac (Wall Charger), includes charger, 2 paks, and power cord	6500-700-041
Kit, Brake Adjuster	6080-700-018
Kit, Brake - Single Wheel, Foot End Right	6080-201-000
Kit, Brake - Dual Wheel, Foot End Left and Right	6082-202-000
Kit, Base Tube Protector	6500-700-015
Kit, Equipment Hook	6500-700-003

Quick Reference Replacement Parts List

Part Name	Part Number
Kit, Lift Capable Safety Bar	6082-700-031
Kit, Oxygen Bottle Holder, Foot End	6500-700-017
Kit, Oxygen Bottle Holder, Fowler	6500-700-011
Kit, Oxygen Bottle Holder, Retractable Head Section	6085-700-003
Label, Base, "Lift Here"	6080-090-008
Label, I.V. Pole Caution	6070-090-005
Label, Damage Warning	6080-090-009
Manual, Installation/Operation, Cot Fastener	6370-090-010
Mattress, Bolster	6090-041-010
Mattress, Flat	6090-042-010
Mounting Bracket, SMRT Charger	6500-201-100
Oxygen Bottle Holder, Foot End	6500-140-000
Oxygen Bottle Holder, Head End	6500-141-000
Oxygen Bottle Holder, Removable	6080-140-000
Oxygen Bottle Holder, Retractable Head Section	6085-046-000
Restraint Belt Extension	6082-160-050
Restraint, Chest	6060-260-046
Restraint, Lap Belt (2 Used per Unit)	6060-160-044
Restraint Package, Domestic	6082-260-010
Restraint, Shoulder Harness	6060-260-045
Restraint Strap Plastic Cap (Short)	6082-160-051
Restraint Strap Plastic Cap (Tall)	6082-160-055
Safety Hook, Long	6060-036-017
Safety Hook, Short	6092-036-018
Siderail Assembly	6060-026-010
Storage Flat Option	6500-128-000
Switch, Control	6500-101-016
Touch-Up Paint (Yellow)	6060-199-010
Touch-Up Paint (Black)	7000-001-322
Valve, "A"	6500-001-286
Valve, "B"	6500-001-287
Valve, Locking	6500-001-288

[Return To Table of Contents](#)

Quick Reference Replacement Parts List

Part Name	Part Number
Valve, Non-Locking	6500-001-289
Velcro® 4.6" Adhesive Loop Pile, Litter	6060-032-046
Velcro® 10"	6082-001-082
Wheel Lock	6082-200-010

Service Information

MANUAL RELEASE CABLE ADJUSTMENT

Tools Required:

- 8mm Combination Wrench
- 10mm Wrench

Procedure:

1. Support the litter so no weight is on the base.
2. Ensure that the cable is intact.
3. Using a 10mm wrench, loosen the cable lock nut.
4. Using a 8mm hex wrench, adjust the tension on the manual release cable.
5. Tighten cable lock nut.

FILLING THE RESERVOIR

Use only Mobil Mercon® V Synthetic Blend Oil (6500-001-293)

Note: Any time you work with the hydraulics you may lose some oil.

Tools Required:

- 3/16" Allen Wrench

Procedure:

1. Raise the cot to the full up position.
2. Ensure that the fill port is horizontal and lined up with the hole in the motor mount.
3. Remove the port plug using a 3/16" Allen wrench.
4. Fill the reservoir up to the bottom of the fill port.
5. Replace the plug and run the cot up and down a few times.

Service Information

WHEEL LOCKING FORCE ADJUSTMENT

Tools Required:

- 5/32" Allen Wrench
- 7/16" Combination Wrench or Socket

Procedure:

1. Using the 5/32" Allen wrench and 7/16" combination wrench or socket, remove the socket screw from the center of the lock pedal. The wheel lock is initially assembled with the pedal set at the minimum locking force. The marker on the pedal (A) is aligned with the marker on the octagonal sleeve (B).
2. Remove the sleeve (B). Rotate the sleeve counterclockwise to increase the pedal locking force and clockwise to decrease the locking force. Insert the sleeve into the pedal.
3. Using the 5/32" Allen wrench and 7/16" combination wrench or socket, reinstall the socket screw.
4. Test the pedal locking force and verify that the pedal holds properly before returning the cot to service.



Figure 55: Wheel Locking Force Adjustment

COT RETAINING POST ADJUSTMENT

Tools Required:

- 3/16" Allen Wrench

CAUTION

The cot retaining post comes preconfigured for an X-frame cot, if the fastener has been configured for an H-frame style cot, the cot retaining post must be adjusted to accommodate the fastener.

Procedure:

1. Using a 3/16" Allen wrench, remove the bolts that hold the two retaining post brackets to the base frame.
2. Turn the bottom bracket 180°.
3. Using a 3/16" Allen wrench, reinstall the bolts that were removed in step 1.

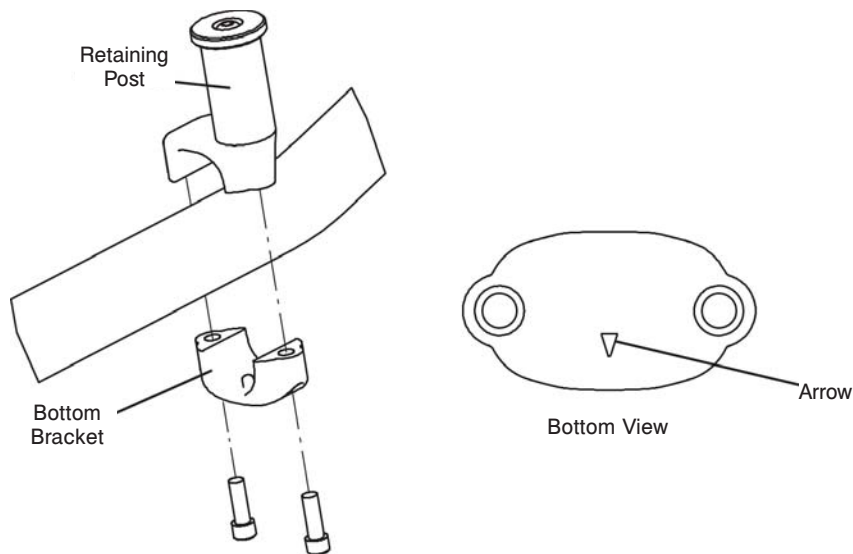

Figure 56: Cot Retaining Post

Note: If the arrow on the bottom bracket of the retaining post points toward the head end of the cot, the retaining post is set for an X-frame style cot. If the arrow points toward the foot end of the cot the post is set for an H-frame style cot.

EMC Information

POWER-PRO™ XT

Guidance and Manufacturer's declaration - Electromagnetic Immunity			
The model 6506 Power-PRO™ XT cot is suitable for use in the electromagnetic environment specified below. The customer or the user of the model 6506 Power-PRO™ XT cot should assure that it is used in such an environment.			
Immunity Test	IEC 60601 Test Level	Compliance Level	Electromagnetic Environment Guidance
Electrostatic Discharge (ESD) IEC 61000-4-2	±6 kV contact ±8 kV air	±6 kV contact ±8 kV air	Floors should be wood, concrete, or ceramic tile. If floors are covered with synthetic material, the relative humidity should be at least 30%. Applies to: • Cot, • SMRT Charger (6500-201-010)
Electrostatic fast Transient/burst IEC 61000-4-4	±2 kV for power supply lines ±1 kV for input/output lines	±2 kV for power supply lines ±1 kV for input/output lines	Main power quality should be that of a typical commercial or hospital environment. Applies to: • SMRT Charger (6500-201-010)
Surge IEC 61000-4-5	±8 kV differential mode ±2 kV common mode	±8 kV differential mode ±2 kV common mode	Main power quality is that of a typical commercial and/or hospital environment. Applies to: • SMRT Charger (6500-201-010)
Voltage dips, voltage variations and short interruptions on power supply input lines IEC 61000-4-11	<5% U_T (>95% dip in U_T) for 0,5 cycle 40% U_T (60% dip in U_T) for 5 cycles 70% U_T (30% dip in U_T) for 25 cycles <5% U_T (>95% dip in U_T) for 5 seconds	<5% U_T (>95% dip in U_T) for 0,5 cycle 40% U_T (60% dip in U_T) for 5 cycles 70% U_T (30% dip in U_T) for 25 cycles <5% U_T (>95% dip in U_T) for 5 seconds	Main power quality should be that of a typical commercial and/or hospital environment. If the user of the charger requires continued operation during power main interruptions, it is recommended that the device be powered from an uninterrupted power supply or a battery.
Power frequency (50/60 Hz) magnetic field IEC 61000-4-8	3 A/m	3 A/m	Power frequency magnetic fields should be at levels characteristic of a typical location in a typical commercial and/or hospital environment. Applies to: • Cot, • SMRT Charger (6500-201-010).
Note: U_T is the alternating current mains voltage prior to application of the test level.			

[Return To Table of Contents](#)

EMC Information

POWER-PRO™ XT (CONTINUED)

Recommended separation distances between portable and mobile RF communications equipment and the Power-PRO™ XT.			
The model 6506 Power-PRO™ XT cot is intended for use in an electromagnetic environment in which radiated RF disturbances are controlled. The customer or the user of the model 6506 Power-PRO™ XT cot can help prevent electromagnetic interferences by maintaining a minimum distance between portable and mobile RF communications equipment (transmitters) and the model 6506 Power-PRO™ XT cot as recommended below, according to the maximum output power of the communications equipment.			
Rated maximum output power of transmitter W	Separation distance according to frequency of transmitter		
	m		
	150 kHz to 80 MHz	80 MHz to 800 MHz	800 MHz to 2.5 GHz
	$d=1.17\sqrt{P}$	$d=1.17\sqrt{P}$	$d=2.33\sqrt{P}$
0,01	0,12	0,12	0,23
0,1	0,38	0,38	0,73
1	1,2	1,2	2,3
10	3,8	3,8	7,3
100	12	12	23
For transmitters rated at a maximum output power not listed above, the recommended separation distance d in meters (m) can be estimated using the equation applicable to the frequency of the transmitter, where P is the maximum output power rating of the transmitter in watts (W) according to the transmitter manufacturer.			
Note 1: At 80 MHz and 800 MHz, the separation distance for the higher frequency range applies.			
Note 2: These guidelines may not apply in all situations. Electromagnetic propagation is affected by absorption and reflection from structures, objects and people.			

EMC Information

POWER-PRO™ XT (CONTINUED)

The model 6506 Power-PRO™ XT cot is suited for use in the electromagnetic environment specified below. The customer or the user of the model 6506 Power-PRO™ XT cot should assure that it is used in such an environment.			
Immunity Test	IEC 60601 Test Level	Compliance Level	Electromagnetic Environment - Guidance
Conducted RF IEC 61000-4-6	3 Vrms 150 kHz to 80 MHz	3 Vrms	<p>Portable and mobile RF communications equipment should be used no closer to any part of the model 6506 Power-PRO™ XT cot, including cables, than the recommended separation distance calculated from the equation appropriate for the frequency of the transmitter.</p> <p>Recommended separation distance $d=1.2\sqrt{P}$</p> <p>Applies to:</p> <ul style="list-style-type: none"> • SMRT Charger (6500-201-010)
Radiated RF IEC 61000-4-3	3 V/m 80 MHz to 2,5 GHz	3 V/m	<p>$d=1.2\sqrt{P}$ 80 MHz to 800 MHz</p>
			<p>$d=2.3\sqrt{P}$ 800 MHz to 2.5 GHz</p> <p>where P is the maximum output power rating of the transmitter in watts (W) according to the transmitter manufacturer and d is the recommended separation distance in metres (m).</p> <p>Field strengths from fixed RF transmitters, as determined by an electromagnetic site survey, ^a should be less than the compliance level in each frequency range. ^b</p> <p>Interference may occur in the vicinity of equipment marked with the following symbol:</p> <div style="text-align: center;">  </div>
<p>Note 1: At 80 MHz and 800 MHz, the higher frequency range applies.</p> <p>Note 2: These guidelines may not apply in all situations. Electromagnetic propagation is affected by absorption and reflection from structures, objects and people.</p>			
<p>^a Field strengths from fixed transmitters, such as base stations for radio (cellular/cordless) telephones and land mobile radios, amateur radio, AM and FM radio broadcast, and TV broadcast cannot be predicted theoretically with accuracy. To assess the electromagnetic environment due to fixed RF transmitters, an electromagnetic site survey should be considered. If the measured field strength in the location in which the model 6506 Power-PRO™ XT cot is used exceeds the applicable RF compliance level above, the model 6506 Power-PRO™ XT cot should be observed to verify normal operation. If abnormal performance is observed, additional measures may be necessary, such as reorienting or relocating the model 6506 Power-PRO™ XT cot.</p> <p>^b Over the frequency range 150 kHz to 80 MHz, field strengths are less than 3 V/m.</p>			

[Return To Table of Contents](#)

EMC Information

POWER-PRO™ XT (CONTINUED)

Guidance and Manufacturer's declaration - Electromagnetic Emissions		
The model 6506 Power-PRO™ XT cot is intended for use in an electromagnetic environment specified below. The customer or the user of the model 6506 Power-PRO™ XT cot should assure that it is used in such an environment.		
Emissions Test	Compliance	Electromagnetic Environment
RF Emissions CISPR 11	Group 1	The model 6506 Power-PRO™ XT cot uses RF energy only for its internal function. Therefore, its RF emissions are very low and are not likely to cause any interference in nearby electronic equipment.
RF Emissions CISPR 11	Cot: Class A	The model 6506 Power-PRO™ XT cot is suitable for use in all establishments other than domestic and those directly connected to the public low-voltage power supply network that supplies buildings used for domestic purposes.
	SMRT Charger (6500-201-010): Class A	The SMRT Charger is suitable for use in all establishments other than domestic establishments other than domestic and those directly connected to the public low-voltage power supply network that supplies buildings used for domestic purposes.
Harmonic Emissions IEC 61000-3-2	Cot: N/A	
	SMRT Charger (6500-201-010): Class A	
Voltage Fluctuations Flicker Emissions IEC 61000-3-3	Cot: N/A	
	SMRT Charger (6500-201-010): Complies	

Warranty

Stryker EMS, a division of the Stryker Corporation, offers one warranty option in the United States:

Two (2) year parts and labor. Stryker EMS warrants to the original purchaser that its products should be free from manufacturing non-conformances that affect product performance and customer satisfaction for a period of two (2) years after date of delivery. Stryker's obligation under this warranty is expressly limited to supplying replacement parts and labor for, or replacing, at its option, any product that is, in the sole discretion of Stryker, found to be defective. Expendable components, i.e. mattresses, restraints, I.V. poles, storage nets, storage pouches, oxygen straps, and other soft goods, have a one (1) year limited warranty.

The Stryker Power-PRO XT is designed for a 7 year expected service life under normal use conditions, and with appropriate periodic maintenance as described in the maintenance manual. Stryker warrants to the original purchaser that the welds on the Power-PRO XT will be free from structural defects for the expected 7 year life of the product as long as the original purchaser owns the product. Original purchasers will also obtain a three (3) year limited parts warranty for the X-frame components of the Power-PRO cot and a three (3) year limited power train warranty covering the motor pump assembly and hydraulic cylinder assembly. Stryker's obligation under this three (3) year limited warranty is expressly limited to supplying replacement parts and labor for, or replacing, at its option, any part that is, in the sole discretion of Stryker, found to be defective.

SMRT Power Warranties. Stryker EMS warrants the SMRT Charger for the same duration as the Stryker product for which it is furnished. All SMRT Paks are warranted to be free from manufacturing non-conformances that affect product performance and customer satisfaction for a period of one (1) year.

Upon Stryker's request, purchaser shall return to Stryker's factory any product or part (freight prepaid by Stryker) for which an original purchaser makes a warranty claim.

Any improper use or alteration or repair by unauthorized service providers in such a manner as in Stryker's judgment affects the product materially and adversely, shall void this warranty. Any repair of Stryker products using parts not provided or authorized by Stryker shall void this warranty. No employee or representative of Stryker is authorized to change this warranty in any way.

This statement constitutes Stryker EMS's entire warranty with respect to the aforesaid equipment. STRYKER MAKES NO OTHER WARRANTY OR REPRESENTATION EITHER EXPRESSED OR IMPLIED, EXCEPT AS SET FORTH HEREIN. THERE IS NO WARRANTY OF MERCHANTABILITY AND THERE ARE NO WARRANTIES OF FITNESS FOR ANY PARTICULAR PURPOSE. IN NO EVENT SHALL STRYKER BE LIABLE HEREUNDER FOR INCIDENTAL OR CONSEQUENTIAL DAMAGES ARISING FROM OR IN ANY MANNER RELATED TO SALES OR USE OF ANY SUCH EQUIPMENT.

Warranty

STRYKER EMS RETURN POLICY

Cots, Stair Chairs, Evacuation Chairs, Cot Fasteners and Aftermarket Accessories may be returned up to 180 days of receipt if they meet the following guidelines:

Prior to 30 Days

- 30 day money back guarantee in effect
- Stryker EMS is responsible for all charges
- Returns will not be approved on modified items

Prior to 90 Days

- Product must be **unused, undamaged** and in the original packaging
- Customer is responsible for a 10% restocking fee

Prior to 180 Days

- Product must be **unused, undamaged** and in the original packaging
- Customer is responsible for a 25% restocking fee

RETURN AUTHORIZATION

Stryker customer service department must approve any merchandise return and will provide an authorization number to be printed on any returned merchandise. Stryker reserves the right to charge shipping and restocking fees on returned items. SPECIAL, MODIFIED, OR DISCONTINUED ITEMS NOT SUBJECT TO RETURN.

DAMAGED MERCHANDISE

ICC Regulations require that claims for damaged merchandise must be made with the carrier within fifteen (15) days of receipt of merchandise. DO NOT ACCEPT DAMAGED SHIPMENTS UNLESS SUCH DAMAGE IS NOTED ON THE DELIVERY RECEIPT AT THE TIME OF RECEIPT. Upon prompt notification, Stryker will file a freight claim with the appropriate carrier for damages incurred. Claim will be limited in amount to the actual replacement cost. In the event that this information is not received by Stryker within the fifteen (15) day period following the delivery of the merchandise, or the damage was not noted on the delivery receipt at the time of receipt, the customer will be responsible for payment of the original invoice in full.

Claims for any short shipment must be made within thirty (30) days of invoice.

INTERNATIONAL WARRANTY CLAUSE

This warranty reflects U.S. domestic policy. Warranty outside the U.S. may vary by country. Please contact your local Stryker Medical representative for additional information.

PATENT INFORMATION

The Stryker Power-PRO XT cot is covered by one or more of the following patents:

United States	5,537,700	5,575,026	6,908,133	7,398,571	7,540,047
---------------	-----------	-----------	-----------	-----------	-----------

Other patents pending

The Stryker SMRT Power System is covered by one or more of the following patents:

United States	5,977,746	6,018,227
---------------	-----------	-----------

Other patents pending



United States

Stryker Medical
3800 E. Centre Ave.,
Portage, Michigan USA
49002

EC	REP
----	-----

European Representative

Stryker France
ZAC Satolas Green Pusignan
Av. De Satolas Green
69881 MEYZIEU Cedex
France



stryker[®]