

DECT
6.0

DECT 6.0
Cordless Telephone
with Caller ID



800401

DECT

6.0

CONTENTS

Important Information

- 6 What's in the box?
- 7 For your safety
- 7 Installation requirements
- 7 Need help

Your Phone Overview

- 8 Overview of the handset
- 9 Handset Keys
- 10 Display icons
- 11 Base station overview
- 12 Menu navigation

Connect

- 13 Connect to the base station
- 13 Position the base station
- 14 Connect the cables

Install

- 15 Install and charge the handset batteries
- 15 Battery life and range
- 16 Out of range
- 17 Setting up your phone

Call

- 18 Make a call
- 20 Call in progress

CONTENTS(cont.)

- 22 Hotkeys
- 22 Intercom
- 23 Three party conference call
- 23 Call waiting
- 24 Caller identification
- 24 Voicemail

Phonebook

- 25 View and dial phonebook entries
- 26 Edit phonebook entry
- 28 Copying phonebook entries
- 29 Dialing code
- 30 Useful numbers

Calls List

- 32 Calls List
- 33 Viewing the calls list
- 35 Access the redial list

Clock & Alarm

- 36 Date & time
- 37 Alarm

Settings

- 38 Handset setting
- 45 Base settings
- 47 System PIN
- 47 Factory Default

CONTENTS(cont.)

Registration

48 Registration

50 Switch Bases

Troubleshooting

52 Troubleshooting

General Information

54 Conformity

55 Recycling and disposal



Congratulations on your selection of this quality product by **XACT Communication**. With proper care and adherence to the set-up and user instructions in this Owner's Manual, this unit will provide you with years of trouble-free service. **XACT** is committed to providing quality products that fit your needs. We would like to have any comments or suggestions you might have on this product. You may mail your comments to:

XACT Communication, LLC
105 Madison Avenue
New York, NY 10016
info@xactcommunication.com

WHAT'S IN THE BOX?

User manual
Edge 1.4 handset
Edge 1.4 base station
Line cord
Power adapter for base station
Battery door
2 x AAA rechargeable batteries
Warranty information

In the event that any item is missing or if you find any mismatch or damage, promptly contact your retailer.

FOR YOUR SAFETY

This equipment is not designed to make emergency calls in the event of a power failure. An alternative means of communication must be available to make emergency calls when this phone has no power.

- Do not allow the product to come into contact with liquid.
- Do not open it as you could be exposed to high voltages.
- Never use any battery type other than the one supplied. There is a risk of explosion if the batteries are replaced by an incorrect type. Dispose of used batteries according to all applicable laws and regulations.
- When the phone is ringing or when activating the speaker phone, please do not hold the handset too close to your ear as it may damage your hearing.

INSTALLATION REQUIREMENTS

This product requires an electrical supply of 110 volts of alternating current. In case of power failure, the communication will be lost. The electrical network is classified as hazardous according to criteria in the standard **UL 60-950**. The only way to power down this product is to unplug the power supply unit from the electrical outlet. Ensure the electrical outlet is located close to the apparatus and is always easily accessible.

The voltage on the network is classified as **TNV-3 (Telecommunication Network Voltages)**, as defined in the standard **EN 60-950**.

NEED HELP?

Troubleshooting on Page 50-53

Online Help: www.getxact.com

OVERVIEW OF THE HANDSET

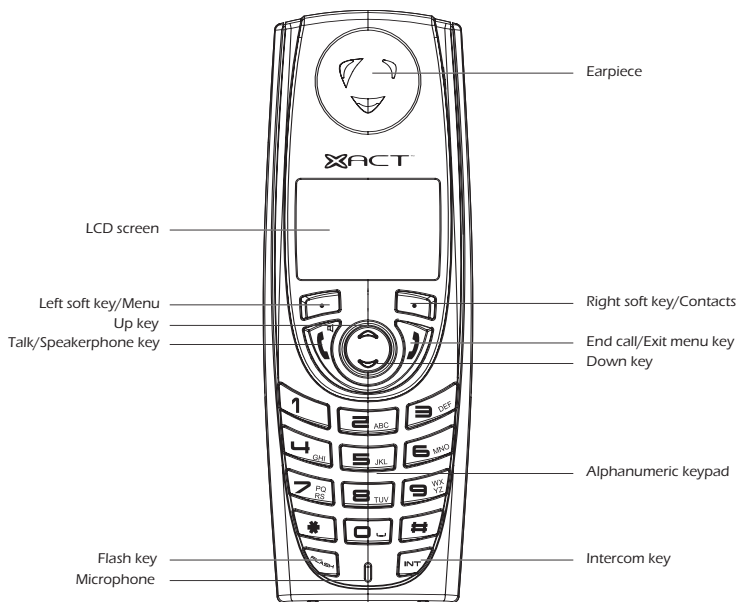

HANDSET KEYS

Press

To



Up/Down Key
Scroll through lists and menus
Increase earpiece volume or speaker volume



Answer a call
Switch between handset and speakerphone during a call



End a call
Exit a menu key

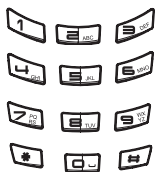

Alphanumeric keypad



Switch between phone calls



Intercom

SOFT KEYS

The soft keys are the  and  keys directly below the screen.



Right soft key (Menu)



Left soft key (Contacts)



DISPLAY ICONS



Status Icon

Description



Handset battery charge level



Ringer volume is set to 'off'



Alarm clock is activated

Reminder Icon

Description



New voicemail messages on your network answer service



Missed call

BASE STATION OVERVIEW

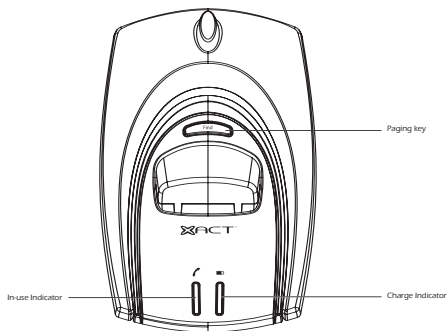

Here is a quick view of the menu options available on your phone.

For a full explanation of each menu option, see the detailed sections in this User Manual.

MENU

Add Names, edit and manage your phonebook entries

Calls Lists Display details missed, received, dialed and network voicemail calls. Call, save or delete numbers.

Useful Numbers Store up to 10 important phone numbers for easy dialing

Clock & Alarm Set the date and time, set an alarm time

Handset Settings Set ring tone, ringer volume, receiver volume, handset name, language, wallpaper, screensaver and more on the handset.

Base Settings Set dialing mode, ring priority, system PIN, master reset and more on the base station

Registration Register and unregister handsets. Select preferred base. Paging key



MENU NAVIGATION



The basic steps of navigating through the menus and on-screen options:

(1) From the standby screen, press **Menu**.

The main menu is opened.



(2) Use  scroll through the options and press

Select to open the menu displayed.



(3) Use the  and  soft keys to select on-screen options, eg.

Select to choose the highlighted option, or **Back** to return to the previous menu.

STANDBY MODE

If you do not press any button on the handset for 30 seconds the display will automatically return to standby mode. It will also return to standby mode if the handset is placed on the base station.

CONNECT TO THE BASE STATION

Note: The position in which you placed the base station can have an effect on the range and performance of your phone. Avoid placing the base station too close to large metal objects such as filing cabinets, radiators or electrical appliances. This can impair the range and sound quality. Buildings with thick internal and external walls may impair transmission of signals to and from the base.

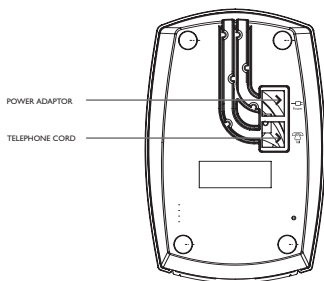

POSITION THE BASE STATION

Place the base station within reach of the telephone line and electrical outlets.



CONNECT THE CABLES

(1.) Plug the line cord and the power cable to the appropriate ports on the bottom of the base station as shown. Make sure you connect the power adapter and telephone line cord correctly, as incorrect connection could damage the unit. Always use the telephone line cord supplied with the unit. Otherwise, you may not get a dial tone.

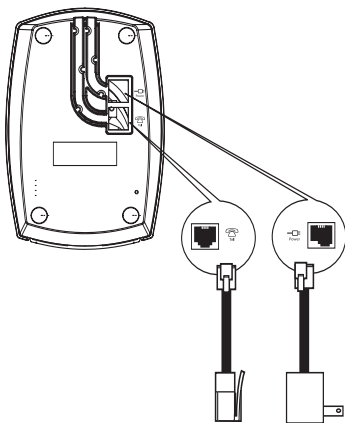

(2) Plug the other end of the line cord and power cable into the telephone wall socket and electrical power outlet. The line adapter may not be attached to the line cord. If this is the case, please connect the line cord to the line adapter before plugging it into the electrical outlet.

WARNING: The base station does not have an ON/OFF switch. Power is applied when the power adapter is plugged into the unit and connected to the electrical outlet. The only way to power down the unit is to unplug the power adapter from the electrical outlet. Therefore, ensure that the electrical outlet is easily accessible. The power cord may also be disconnected from the base station.

INSTALL AND CHARGE THE HANDSET BATTERIES

- (1) Slide off the battery door (if fitted).
- (2) Insert the batteries as shown. Slide the battery door back in place.

Charge Batteries

- (1) Place the Edge 1.4 handset face-up on the base station. A beep confirms that the handset is placed correctly.

A charging animation on the handset screen shows that the battery is charging.

- (2) Leave the handset on the base station until the batteries are fully charged (at least 24 hours).

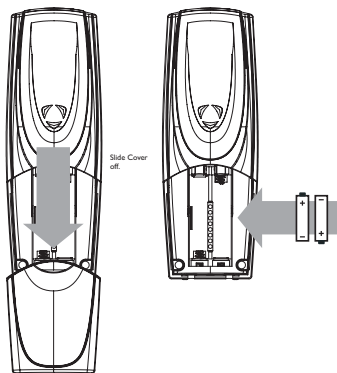

The handset batteries are fully charged when the charging animation stops and the full battery icon is displayed.

BATTERY LIFE AND RANGE

Talk time and standby time

When the battery is fully charged, the talk time of your Edge 1.4 is approximately 12 hours and the standby time is approximately 150 hours.

Low battery warning

The battery level is shown in the top left-hand corner of the handset screen. If the battery level becomes low, you will hear a beep and the icon will flash.



BATTERY LIFE (CONT.)

A low battery alert will inform you that the handset has to be recharged. If this happens during a call, the call may end shortly after the alert. If the battery level becomes exceedingly low, the phone automatically switches off shortly after the alert. Any function in progress will not be saved.

The approximate power levels of your battery are indicated as follows:



Battery is fully charged



Battery is partially charged



Battery is running low



Battery is almost fully discharged



Out of Range Warning

In ideal conditions, the range of the phone may exceed 150 feet indoors and 1000 feet outdoors. If the handset moves outside this range, the display will show *Searching...* then *Not Available*. Move back towards the base to ensure your connection remains established.

SETTING UP YOUR PHONE

You may wish to set the display language to an alternate language when you first use your phone. The default language is English (US)

If the Welcome Screen Appears

- (1) The welcome screen will briefly appear, then a list of countries is displayed.
- (2) Scroll  to your country and press **Select**. A list of network operators is displayed. If you made an incorrect entry, press **Back**.
- (3) Scroll  to your operator, and press **Select**.

The standby screen is displayed and your phone is ready to use. You can still make and receive calls without first selecting your country and network operator, however the Welcome screen will appear after each call.

If the Welcome Screen Does Not Appear

Your language and network operator has been preset at the factory.



MAKE A CALL

- (1) Press . Display shows **Dialing**.
- (2) Enter the number



Pre-dial

- (1) Enter the phone number (maximum 32 digits). If you make an error, press **Clear** to delete the last digit.
- (2) Press  to dial the number.



Call from the phonebook

- (1) Press  in standby mode.
- (2) Scroll  to a phonebook entry.
- (3) Press  to dial the number.





Search alphabetically for phonebook entries

- (1) Press **Names** then press **Select** to choose **Search**.
- (2) Press the numeric key containing the first letter of the name you want. For example, pressing  will show the entries starting with **A**. Pressing  again will show the entries starting with **B**, etc...

Call from the useful numbers list

- (1) Press **Menu** and scroll  to **Useful Numbers**.
- (2) Press **Select** and scroll  to the number.
- (3) Press **Dial** to dial the number.

Call from the call lists

- (1) Press **Menu** and scroll  to **Calls Lists**.
- (2) Press **Select** and scroll  to the **Calls List** you want.
- (3) Press **Select** and scroll  to an entry.
- (4) Press  to dial the number.

You need to subscribe to your network's Caller Line Identification (Caller ID) service to be able to see the caller's number in the Missed and Received Calls logs.

Answer a call

- (1) When the phone rings, press .





Note: If Auto Talk mode is activated, you can simply lift up the handset from its base station to answer the call. The default setting is off.

An incoming call has priority over other events. Whenever there is an incoming call, other status in progress such as phone setting, menu navigation, etc. will be aborted.

WARNING: When the handset rings during an incoming call, please do not hold the handset too close to your ear as the volume of the ringing tone may damage your hearing.



Answer a call in hands free mode (Speaker Phone)

- (1) When the phone rings, press  then press  again. The call is transferred to the handset loudspeaker. The icon  is displayed
- (2) Press  to switch between the earpiece and loudspeaker.

WARNING: Switching on the Speaker Phone mode can suddenly increase the volume in the earpiece to a higher level than expected. Make sure the handset is not too close to your ear when first activating this mode.

End a call

- (1) Press  to end a call.

The call duration will be displayed on the handset screen for 5 seconds.

CALL IN PROGRESS

The following options are available during a call:

Adjust earpiece volume



- (1) Press  or to adjust the volume .

Mute

You can mute the microphone so that you can talk to someone else in the room without your caller hearing you.

- (1) Press **Mute** to turn the microphone off.
- (2) Press **Off** to turn the microphone back on.

Speaker Phone (Hands free) mode

(1) During a call, press  to switch on the loudspeaker. Press  again to switch the call back to the earpiece.



WARNING: Switching on hands free mode can suddenly increase the volume in the earpiece to a very high level. Make sure the handset is not too close to your ear.

Adjust loudspeaker volume

(1) Press  to adjust the volume displayed on-screen.



HOTKEYS (1-3)

Your phone can have three numbers stored under the ,  and  keys which allow quick dialing of network service numbers, eg. directory services or voicemail.



Dial a stored number (hotkey)

(1) Press and hold the hotkey you wish to dial. The stored number is automatically dialed.

INTERCOM

This feature is only available when there are at least 2 registered handsets. It allows you to make internal calls, transfer external calls from one handset to another and use the conference call option.

Call another handset



- (1) Press . If there are only two handsets, the other handset is called automatically.
- (2) If there are more than two handsets, on your handset dial the number of the other handset, for example , then press **OK**.

Or, press  to call all handsets.

- (3) Press to  end the call.



If the handset does not belong to the DECT frequency range, this function may not be available.

Transfer an external call to another handset



- (1) During an external call, press . Your caller is put on hold.
- (2) Enter the number of the other handset and press **OK**.
- (3) When the other handset answers you can announce the caller. Or press  to return to your external caller.
- (4) Press  to transfer the call.

If the other handset is engaged, the screen shows **Not Available**, press  to speak to your caller again.

Switch between an internal and external call



- (1) During an external call, press . Your caller is put on hold.
- (2) Enter the number of the other handset and press **OK**.
- (3) When the other handset answers you can speak privately to your internal caller.
- (4) Press  to transfer a call back and forth.
- (5) Press  to hang up.

THREE-PARTY CONFERENCE CALL

- (1) During an external call, press . Your caller is put on hold.
- (2) Enter the number of the other handset and press **OK**.
- (3) When the other handset answers, press  to join both calls together. The display shows **Conference Call**.
- (4) Press to  hang up.

CALL WAITING

If you have subscribed to a Call Waiting service, the earpiece will emit a beep tone to inform you that there is a second incoming call. The number or name of the second caller will also be displayed (if you have subscribed to Caller Line Identification service). Please contact your network provider for more information on these services.

- (1) To answer the second call and put your first call on hold, press .
- (2) To switch between both callers, press .
- (3) Press  to hang up with the person you are talking to and return to the caller on hold.



CALLER IDENTIFICATION

If you have subscribed to a Caller Line Identification (Caller ID) service, the number of the caller will be displayed together with the date & time of the call (if provided by the network). If the number matches an entry in the phonebook, the name will be displayed instead. For some incoming calls the telephone number may not be available. The handset will display an alternative explanation, for example:

<i>Unavailable</i>	the number is not available
<i>Withheld</i>	the caller has withheld their number
<i>Ringback</i>	it is a Ringback call
<i>Operator</i>	the call has been made through the operator
<i>Payphone</i>	the caller is ringing from a payphone
<i>International</i>	it is an international number



Information about incoming calls may vary by network operator. Some operators may charge a subscription fee for their Caller Identification (Caller ID) service.



VOICEMAIL

If you have subscribed to your network operator's voicemail messaging service, your handset can inform you when you receive new voicemail. If you have new voicemail, *You have new voicemail* is displayed.

- Press **Listen** to listen to your voicemail. Your handset will automatically dial your voicemail messaging service.
- Or press **Back** to listen to your voicemail at a later time. A reminder icon  will be displayed indicating the number of messages.

View and dial phonebook entries

- (1) Press  down in standby mode to open the phonebook. If there are entries stored they are listed in alphabetical order.
- (2) Scroll  up or down to browse the phonebook.

Note: Instead of scrolling  to browse the phonebook entries, you can press the numeric key corresponding to the first letter of the entry you wish to locate. For example, pressing  will show the entries starting with **A**. Pressing  again will show the entries starting with **B**, etc...

- (3) Press  to dial the displayed entry. Or to view details of a phonebook entry, press **Options** then **Select**.
- (4) Press **Back** to return to standby mode.

Add entry in the phonebook

You can store up to 50 entries. Each entry must included a name and number.





- (1) Press **Names**.
- (2) Scroll  to **Add Entry** and press **Select**.
- (3) Enter the name (see next page). Press **Select**.
- (4) Enter the number. Press **Select**.
- (5) If you wish, scroll to select a ring tone. Press **Select**.
- (6) The display shows **Name Saved**. Press **Back** to return to standby mode.

Ring tones

You can choose a different ring tones for different numbers. For example, assign one ring tone for friends and family and another for work. When the phone rings, you will have an audible indication of who is calling.

Note: This feature requires a subscription to a Caller Line Identification (Caller ID) service.





Text and number entry

For example, to enter the name 'Paul': Press  once to enter **P**, press  once to enter **A**, press  twice to enter **U**, then press  three times to enter **L**. If you make a mistake, press **Clear** to delete the last character.





Names can be up to 12 characters and numbers up to 24 digits. The number of available characters/digits remaining is shown at the top right of the display.

When entering a name, the first character is automatically given as an upper case letter with the rest of the name in lower case lettering. Press  to switch between upper and lower case, the **Abc** icon indicates the current letter case.



Edit phonebook entry

- (1) Press  down in standby mode.
- (2) Scroll  up or down to the entry and press **Options**.
- (3) Scroll  to **Edit Entry** and press **Select**. Press **Clear** to delete current name. Enter the new name then press **OK**.
- (4) Press **Clear** to delete current number. Enter the new number then press **OK**.
- (5) Scroll  to select the ring tones. Press **Select**.
- (6) The display shows **[Entry] Saved**. Press **Back** to return to standby.

Change ring tone for an entry

- (1) Press  down in standby mode.
- (2) Scroll  up or down to the entry and press **Options**.
- (3) Scroll  up or down to **Edit Entry** and press **Select**.
- (4) Press **Select** twice to display the list of ring tones.
- (5) Scroll  to the ring tone you want and press **Select** to save the changes.
The display shows **[Entry] Saved**.
- (6) Press **Back** to return to standby.

Delete phonebook entry

- (1) Press  down in standby mode.
- (2) Scroll  up or down to the entry and press **Options**.
- (3) Scroll  down to **Delete Entry** and press **Select**. The display shows **Delete Entry?**.
- (4) Press **Yes** to confirm or **No** to cancel. If **Yes** is selected the display shows **[Entry] Deleted**.
- (5) Press **Back** to return to standby.





Delete all phonebook entries

- (1) Press **Names**.
- (2) Scroll  to **Delete Phonebook** and press **Select**. Screen shows **Delete All?**.
- (3) Press **Yes** to confirm or **No** to cancel. If **Yes** is selected the display shows **All Entries Deleted**.
- (4) Press **Back** to return to standby.

COPYING PHONEBOOK ENTRIES

When copying phonebook entries, the other handset must be registered to the same base as your handset. If the other handset does not belong to the correct DECT range, this function may not be available.

Copy entry to another handset

- (1) Press  down in standby mode.
- (2) Scroll  up or down to the entry and press **Options**.
- (3) Scroll to **Copy Entry** and press **Select**.
- (4) **To Handset** is highlighted. Press **Select**.
- (5) Scroll  up or down to the destination handset number and press **Select**. The display shows **Copying [Entry]** and the entry is copied. Once copied, the display shows **[Entry] Copied**.
- (6) Select another entry to be copied or press **Back** to return to standby.

If the receiving handset memory is full, it displays **Phonebook Memory Full**.
The sending handset displays **Copying Unsuccessful**.



Copy phonebook to another handset

- (1) Press **Names** in standby mode.
- (2) Scroll  up or down to **Copy Phonebook** and press **Select**.
- (3) Press **Select** to choose **To handset** then scroll to the destination handset number.
- (4) Press **Select** to begin copying. The display shows **Copying...** On completion the number of entries copied is displayed.
- (5) Press **Back** to return to standby. At the receiving handset. The display shows **Replace Phonebook?**. Press **Yes** to confirm or **No** to cancel.

Check phonebook memory status

- (1) Press **Names** in standby mode.
- (2) Scroll  up or down to **Memory Status** and press **Select**. The display shows how much storage space remains in the phonebook memory.
- (3) Press **Back** to return to standby.

DIALING CODE

You can automatically give all numbers in the phonebook an international, national and local dialing code prefix.



Set dialling code prefix

- (1) Press **Names** in standby mode.
- (2) Scroll  up or down to **Dialing Codes** and press **Select**.
- (3) Scroll to **International**, **Country** or **Local** and press **Select**.
- (4) Enter the relevant code and press **Save**. The display shows **Code Saved**.
- (5) Set another code, or press **Back** to return to standby.

USEFUL NUMBERS

Store a useful number



Store up to 10 of your most important or useful numbers or dialing prefixes in the useful numbers list, for example help lines, directory services, etc.

- (1) Press **Menu**, scroll  up or down to **Useful Numbers** and press **Select**.
- (2) Scroll  to an empty space and press **Options**.
- (3) Scroll  down to **Edit** and press **Select**.
- (4) Enter the name and press **Save**.
- (5) Enter the number and press **Save**.
- (6) Press **Back** to return to standby.



View and dial a useful number

- (1) Press **Menu**, scroll or to **Useful Numbers** and press **Select**.
- (2) Scroll  to the entry and press **Options**.
- (3) Press **Select** to choose Show **Details**.
- (4) Press **Dial** to call the number. If the number is a prefix, you can enter the rest of the number or add an entry from the phonebook. Press **Back** to return to standby mode.

Edit a useful number

- (1) Press **Menu**, scroll  up or down to **Useful Numbers** and press **Select**.
- (2) Scroll  up or down to the entry and press **Options**.
- (3) Scroll  down to **Edit** and press **Select**.
- (4) Edit the name, press **Save**.
- (5) Edit the number, press **Save**. The display shows **[Entry] Saved**.
- (6) Press **Back** to return to standby.

Delete a useful number

- (1) Press **Menu**, scroll  to Useful Numbers and press **Select**.
- (2) Scroll  to the entry and press **Options**.
- (3) Scroll  to **Delete** and press **Select**. The display shows **Delete [Entry]?**.
- (4) Press **Yes** to confirm or **No** to cancel. If **Yes** is selected the display shows **[Entry] Deleted**.
- (5) Press **Back** to return to standby.

Delete all useful numbers

- (1) Press **Menu**, scroll  to **Useful Numbers** and press **Select**.
- (2) Press **Options**, scroll to **Delete All** and press **Select**. The display shows **Delete All Entries?**.
- (3) Press **Yes** to confirm or **No** to cancel. If **Yes** is selected the display shows **All Entries Deleted**.
- (4) Press **Back** to return to standby.



CALLS LIST

The calls lists contain details of missed, received and dialed calls. Entries are displayed in chronological order with the most recent call at the top of the list. In order to receive details of received and missed calls you will need to subscribe to a Caller Line Identification (Caller ID) service. Some operators may charge a fee for this service.



The received call list holds details of up to the last 40 calls received and the dialed calls list holds up to 10 of the last numbers dialed. When a calls list is full, a new call replaces the oldest in the list.

Missed calls

When you have missed calls (incoming calls that you haven't answered) the screen will display **You have x new calls**. The alert light on the base will also flash.

- Press **View** to view your missed calls. The screen shows the missed calls list with the newest call at the top. New calls are marked with a green dot.
- Press **Back** to view the calls later. A reminder icon  will be displayed indicating the number of missed calls.





VIEWING THE CALLS LIST

- (1) Press **Menu** and scroll  to **Calls Lists** and press **Select**.
- (2) Scroll  to the list you want: **Missed**, **Received** or **Dialed** and press **Select**.
- (3) Scroll  to view the entries. If the list is empty, the screen displays **Call List(s) Empty**.

If a calls list contains a number from your phonebook, the name stored with the number will be displayed in the calls list(s).

- (4) To view further details about the call, press **Options** then **Select** to choose **Show Details**.
To dial the number displayed, press .
- (5) Press **Back** to return to standby.





Save number from the calls list to the phonebook

- (1) Press **Menu** and scroll  to **Calls Lists**.
- (2) Press **Select** and scroll  to the list you want: **Missed**, **Received** or **Dialed**.
- (3) Press **Select** then scroll  to the entry you want.
- (4) Press **Options** and scroll  to **Save Number**.

Note: The Save Number option will not be available if the number is already stored in the phonebook. If the phonebook is full when **Save Number** is selected, the display will show **Phonebook Memory Full** and returns to the previous screen.

- (5) Press **Select** and enter a name. Press **OK**. The number is displayed.
- (6) Press **Select** and scroll  to select the ring tone. Press **Select** to confirm. The display shows **[Entry] Saved**.
- (7) Press **Back** to return to standby.





Delete a Calls List entry

- (1) Press **Menu** and scroll  to **Calls Lists** and press **Select**.
- (2) Scroll  to the list you want: **Missed**, **Received** or **Dialed** and press **Select**.
- (3) Scroll  to the entry you want and press **Options**
- (4) Scroll  to **Delete Call** and press **Select**. The display shows **Call Deleted**.
- (5) Press **Back** to return to standby.

ACCESS THE REDIAL LIST

- (1) Press  up from standby and scroll  to view the entries.



Save redial list entry to phonebook

- (1) Press  up from standby and scroll  to view the entries.
- (2) Press **Options** and scroll  to **Save Number** and press **Select**.
- (3) Enter a name and Press **Select**. The number is displayed.
- (4) If necessary, edit the number and press **Select**.
- (5) Scroll  to select the ring tone. Press **OK** to confirm.
- (6) Press **Back** to return to standby.

Delete number from redial list

- (1) Press  up from standby and scroll  to the number.
- (2) Press **Options**. Scroll  to **Delete Call** and press **Select**.

Delete the redial list

- (1) Press  up from standby.
- (2) Press **Options**. Scroll  to **Delete All** and press **Select**.
- (3) Press **Yes** to confirm or **No** to cancel.
- (4) Press **Back** to return to standby.

DATE AND TIME

If you have subscribed to a Caller Line Identification (Caller ID) service, the date and time is set when the first incoming call is received. You can also manually set the time and date.



Set the date and time

- (1) Press **Menu**, scroll  to **Clock & Alarm** and press **Select**.
- (2) Press **Select** to choose **Date & Time**.
- (3) Enter the date (DD/MM/YY) then time (HH:MM) in 24-hour format, eg. 7.30pm is 1930. Press **Clear** if you make a mistake.
- (4) Press **Save** then **Back** to return to standby mode.

If you have more than one handset, you only need to set the time and date on one handset. The other handsets are updated automatically.

Set time format

Select the desired clock format, (12 or 24 hours).

- (1) Press **Menu**, scroll  to **Clock & Alarm** and press **Select**.
- (2) Scroll  down to **Time Format** and press **Select**.
- (3) Scroll  to **12 hour** or **24 hour** and press **Select**.
- (4) Press **Back** to return to standby.



If you have more than one handset, you can set a different time format for each.



ALARM

You can set a daily, weekday or one time only alarm. If you have more than one handset, you can set a different alarm on each.

Set/cancel an alarm

- (1) Press **Menu**, scroll  to **Clock & Alarm** and press **Select**.
- (2) Scroll  down to **Alarm** and press **Select**.
- (3) Scroll  to **On** and press **Select**.

To cancel a previously set alarm, press **Select** to choose **Off**, then **Back** to return to standby.

- (4) Scroll  to choose:

Once for a one time only alarm

Mon-Fri for alarm to sound Monday-Friday only

On Daily for the alarm to sound every day

- (5) Press **Select** and enter the desired time for the alarm to activate and press **Save**.
- (6) Press **Back** to return to standby.

When an alarm is set the icon  is displayed.

Silence the alarm

- (1) When the alarm sounds the handset(s) will ring. Press **Stop**.

If the Stop button is not pressed the alarm will stop automatically after 1 minute.



If the handset is in use when the alarm sounds, the  icon will flash and a beep will be heard in the handset earpiece.

HANDSET SETTINGS

Change the ring tone



Choose from 10 ring tones (8 polyphonic).

You can set different ring tones for internal and external calls.

- (1) Press **Menu**, then scroll  down to **Settings** and press **Select**.
- (2) Press **Select** to choose **Set Handset**.
- (3) Press **Select** again to choose **ring tone**, then scroll  to choose **External** or **Internal Calls**.
- (4) Press **Select** and scroll  to choose the ring tone.
- (5) Press **Select** to confirm.
- (6) Press **Back** to return to standby.

Set the ringer volume

There are 5 volume levels. You can also switch the ringer off.



- (1) Press **Menu**, then scroll  down to **Settings** and press **Select**.
- (2) Press **Select** to choose **Set Handset**.
- (3) Scroll  down to **Ringer Volume** and press **Select**.
- (4) Scroll  or to choose the volume level **1-5** or **Ringer Off**.
- (5) Press **Save** to confirm.
- (6) Press **Back** to return to standby.

When Ringer Off is selected is, the icon  is displayed on the screen.

WARNING: When the handset rings during an incoming call, please do not hold the handset too close to your ear as the volume of the ringing tone may damage your hearing.

Set the receiver volume



There are 8 receiver volume levels.

- (1) Press **Menu**, then scroll  down to **Settings** and press **Select**.
- (2) Press **Select** to choose **Set Handset**.
- (3) Scroll  down to **Receiver Volume** and press **Select**.
- (4) Scroll  to choose the volume level **1– 8**.
- (5) Press **Save** to confirm.
- (6) Press **Back** to return to standby.

Change the handset name



You can name the handset and display the handset name in standby mode. The default name of your handset is XACT.

The handset name can be a maximum of 10 characters, e.g. Mike, Kitchen.

- (1) Press **Menu**, then scroll  down to **Settings** and press **Select**.
- (2) Press **Select** to choose **Set Handset**.
- (3) Scroll  down to **Handset Name** and press **Select**.
- (4) Enter the name (up to 10 characters). If you make a mistake, press **Clear** to delete the last character.
- (5) Press **Save** to confirm.
- (6) Press **Back** to return to standby.



Change the display language

View menus and display information in different languages.

- (1) Press **Menu**, then scroll  down to **Settings** and press **Select**.
- (2) Press **Select** to choose **Set Handset**.
- (3) Scroll  down to **Language** and press **Select**.
- (4) Scroll  to choose the language.
- (5) Press **Save** to confirm.
- (6) Press **Back** to return to standby.



Change the wallpaper

The 'wallpaper' is the background image you see on the standby screen.

- (1) Press **Menu**, then scroll  down to **Settings** and press **Select**.
- (2) Press **Select** to choose **Set Handset**.
- (3) Scroll  down to **Wallpaper** and press **Select**.
- (4) Scroll  to choose the wallpaper.
- (5) Press **View** to see the wallpaper.
- (6) Press **Use** to select the wallpaper.
- (7) Press **Back** to return to standby.





Change the menu color

- (1) Press **Menu**, then scroll  down to **Settings** and press **Select**.
- (2) Press **Select** to choose **Set Handset**.
- (3) Scroll  down to **Menu Color** and press **Select**.
- (4) Scroll  to choose the color **Blue**, **Orange** or **Pink**.
- (5) Press **Select** to set the new color.
- (6) Press **Back** to return to standby.



Switch the screensaver on/off

The screensaver displays a clock face plus the time and date. The screensaver comes on when the backlight goes off and will only appear when your handset is in standby.

- (1) Press **Menu**, then scroll  down to **Settings** and press **Select**.
- (2) Press **Select** to choose **Set Handset**.
- (3) Scroll  down to **Screensaver** and press **Select**.
- (4) Scroll  to **Clock** or **Off**.
- (5) Press **Select** to confirm.
- (6) Press **Back** to return to standby.



Set the backlight time

You can set how long the backlight stays active – 15, 30 or 45 seconds.

- (1) Press **Menu**, then scroll  down to **Settings** and press **Select**.
- (2) Press **Select** to choose **Set Handset**.
- (3) Scroll  down to **Light Timeout** and press **Select**.
- (4) Scroll  to 15, 30 or 45 seconds.
- (5) Press **Select** to confirm.
- (6) Press **Back** to return to standby.



Set the display contrast

You can adjust the contrast to suit different lighting conditions.

- (1) Press **Menu**, then scroll  down to **Settings** and press **Select**.
- (2) Press **Select** to choose **Set Handset**.
- (3) Scroll  to **Display Contrast** and press **Select**.
- (4) Scroll  to **Low**, **Medium** or **High**.
- (5) Press **Select** to confirm.
- (6) Press **Back** to return to standby.



Switch Auto Talk on/off

This function enables you to answer a call automatically by simply lifting the handset from the base station or charger and ending a call by returning it to the base station or charger. The default setting is Off. When Auto Talk is switched off, you must always press to answer a call and to end a call.

- (1) Press **Menu**, then scroll  down to **Settings** and press **Select**.
- (2) Press **Select** to choose **Set Handset**.
- (3) Scroll  to **Auto Talk** and press **Select**.
- (4) Scroll  to **On** or **Off**.
- (5) Press **Select** to confirm.
- (6) Press **Back** to return to standby.



Switch key beeps on/off

A single beep is emitted when a key is pressed. You can enable or disable this key beep. The default setting is key beep On.

- (1) Press **Menu**, then scroll  down to **Settings** and press **Select**.
- (2) Press **Select** to choose **Set Handset**.
- (3) Scroll  to **Key Beep** and press **Select**.
- (4) Scroll  to **On** or **Off**.
- (5) Press **Select** to confirm.
- (6) Press **Back** to return to standby.





Set the redial number length

This feature sets the length of numbers stored in the redial list. The maximum length is 32 digits.

- (1) Press **Menu**, then scroll  down to **Settings** and press **Select**.
- (2) Press **Select** to choose **Set Handset**.
- (3) Scroll  to **Redial Length** and press **Select**.
- (4) Scroll  to **Long** or **Short**.
- (5) Press **Select** to confirm.
- (6) Press **Back** to return to standby.

Set the PBX/switchboard access code

If your phone is connected to a PBX/switchboard you may have to dial a number – e.g. 9 – in order get an outside line. You can set this number so that your phone dials it automatically before each number in the phonebook and Useful Numbers lists. You can set an access code and switch the function on or off.





- (1) Press **Menu**, then scroll  down to **Settings** and press **Select**.
- (2) Scroll  down to **Set Handset** and press **Select**.
- (3) Scroll  to **PBX Access Code** and press **Select**.
- (4) Scroll  to **Off, On** or **Set Code** and press **Select**.
- (5) If you choose **Set Code**, enter the access code and press **Save**, you can now use  to switch the code **On** or **Off**.
- (6) Press **Select**.
- (7) Press **Back** to return to standby.

BASE SETTINGS

Set the dialing mode







The default dialing mode setting is suitable for your country and network operator. It is unlikely that you should need to change this setting.

When connected to certain switchboards or public exchanges, you may need to switch from tone to pulse dialing.

- (1) Press **Menu**, then scroll  down to **Settings** and press **Select**.
- (2) Scroll  down to **Set Base** and press **Select**.
- (3) Scroll  to **Dialing Mode** and press **Select**.
- (4) Scroll  to **Tone** or **Pulse**.
- (5) Press **Save** to confirm.
- (6) Press **Back** to return to standby.





To set ring priority

If you have more than one handset, all handsets normally ring at the same time. You can set one handset to ring 2, 4 or 6 rings before the others. This gives one person the chance to act as a receptionist and answer incoming calls first. Calls can then be transferred to other handsets.

- (1) Press **Menu**, then scroll  down to **Settings** and press **Select**.
- (2) Scroll  down to **Set Base** and press **Select**.
- (3) Scroll  to **Ring Priority** and press **Select**.
- (4) Scroll  to **All Handsets** or **Select Handset** and press **Select**.
- (5) If you chose **Select Handset**, scroll  to the handset number you want to ring first and press **Select**. Then press  to choose the number of rings that will be heard before the other handsets start ringing and press **Select** again.
- (6) Press **Back** to return to standby.





Set the recall mode

The  key is used with certain network services and PBX/switchboard services. You will not normally need to change this setting unless advised to do so.

- (1) Press **Menu**, then scroll  down to **Settings** and press **Select**.
- (2) Scroll  down to **Set Base** and press **Select**.
- (3) Scroll  to **Recall Mode** and press **Select**.
- (4) Scroll  to **Recall** or **Recall 2**.
- (5) Press **Select** to confirm.
- (6) Press **Back** to return to standby.

Set first ring



When this function is set to **Off**, the first ring from a voice call will not sound. This is particularly useful in countries where caller identity (Caller ID) is sent after the first ring, the phone would not ring without displaying Caller ID information.

- (1) Press **Menu**, then scroll  down to **Settings** and press **Select**.
- (2) Scroll  down to **Set Base** and press **Select**.
- (3) Scroll  to **First Ring** and press **Select**.
- (4) Scroll  to choose **On** or **Off**.
- (5) Press **Select** to confirm.
- (6) Press **Back** to return to standby.

SYSTEM PIN

The system PIN is a 4-digit code which is used as a security check when changing certain settings. The default system PIN is **0000**; this can be changed for increased security.



Change system PIN

- (1) Press **Menu**, then scroll  down to **Settings** and press **Select**.
- (2) Scroll  down to **Set Base** and press **Select**.
- (3) Scroll  to **System PIN** and press **Select**.
- (4) Enter the current PIN and press **Save**.
- (5) Enter the new PIN and press **Save**.
- (6) Re-enter the new PIN and press **Save**.
- (7) Press **Back** to return to standby.

FACTORY DEFAULT

This restores all the original settings to your phone. However, entries stored the phonebook and handset registrations will not be affected.

To achieve a Factory Default

- (1) Press **Menu**, then scroll  down to **Settings** and press **Select**.
- (2) Scroll  down to **Set Base** and press **Select**.
- (3) Scroll  to **Factory Default** and press **Select**.
- (4) Press **Yes** to confirm or **No** to cancel
- (5) If **Yes** is selected, enter your System PIN (default setting **0000**).
- (6) Press **OK** and wait while your phone is reset.

REGISTRATION

Up to 5 handsets can be registered to one base station. Additional handsets must be registered to the base unit before you can use them. Your handset can also be registered to a total of 4 bases. You can then select the base you want to use. For example, one at work and another at home.

The instructions below apply specifically to your XACT Edge 1.4 handset. If you wish to register another manufacturer's handset, the instructions may vary. In this case, please refer to the manufacturer of the additional handset. The system PIN is required before you can register or unregister handsets. The default PIN is 0000.



Register a handset to a base

(1) Press and hold  the button on the base station for 3 seconds. The indicator light on the base will flash to show the registration process has begun. The base station is able to accept registration from a handset within 60 seconds. If no key is pressed within 10 seconds, the registration procedure will be aborted.

(2) At the handset, press **Menu** the scroll  down to **Registration** then press **Select**.

(3) Press **Select** again to choose **Register Handset**.

(4) Scroll  to select the **Base** and press **Select**.

(5) Enter the system PIN (the default setting is **0000**) and press **OK** to start registration.

If the base is found and the PIN is correct, the unused handset numbers will be shown and you can select a handset number by entering the number directly.

If the PIN is incorrect, **Incorrect PIN** will be displayed and the handset returns to standby mode.

A long confirmation tone is emitted to indicate successful registration and the screen displays **Handset Registered** before returning to standby mode.



If the registration fails, the display shows **Registration Unsuccessful**. Try repeating the registration process.

If registration is unsuccessful make sure that there are not 5 handsets already registered to the base. If there are, you must unregister one of the handsets in order to register the new one.

SWITCH BASES

If your handset is registered to more than one base, you can switch between them.



Switch bases

- (1) At the handset, press **Menu** then scroll  down to **Registration** and press **Select**.
- (2) Scroll  down to **Select Base** and press **Select**.
- (3) **In Use** is shown next to the base currently being used by the handset. Scroll  to select a new base and press **Select**.
- (4) Enter the system PIN of the base station and press **OK** to start registration.

UNREGISTER A HANDSET



You can use one handset to unregister another.

To unregister a handset

- (1) Press **Menu** then **Select**
- (2) Scroll  to **Registration** and press **Select**.
- (3) Scroll  to **Unregister** and press **Select**.
- (4) Enter the system PIN (original setting **0000**) and press **OK**.
- (5) Scroll  to the handset to be unregistered and press **Select**.
- (6) Press **Yes** to confirm or **No** to cancel.

Paging

Paging is a useful way of finding lost handsets.

- (1) Press  on the base. All handsets ring and display **Paging Call**.
- (2) Press  again to cancel the paging call.

FCC Interference Information

□

This device complies with Part 15 of the FCC Rules. Operation is subject to the following two conditions: (1) This device may not cause harmful interference; and (2) This device must accept any interference received, including interference that may cause undesired operation.

□

This equipment has been tested and found to comply with the limits for a Class B digital device, pursuant to Part 15 of the FCC Rules. These limits are designed to provide reasonable protection against harmful interference in a residential installation.

This equipment generates, uses, and can radiate radio frequency energy and, if not installed and used in accordance with the instructions, may cause harmful interference to radio communications. However, there is no guarantee that interference will not occur in a particular installation.

□

If this equipment does cause harmful interference to radio or television reception, which can be determined by turning the equipment off and on, the user is encouraged to try to correct the interference by one or more of the following measures:

- Reorient or relocate the receiving antenna (that is, the antenna for radio or television that is “receiving” the interference).
- Reorient or relocate and increase the separation between the telecommunications equipment and receiving antenna.
- Connect the telecommunications equipment into an outlet on a circuit different from that to which the receiving antenna is connected.

□

FCC RF Radiation Exposure Statement

□

The installation of the base unit should allow at least 20 centimeter between the base and persons to be in compliance with FCC RF exposure guidelines. For body worn operation, the portable part (handset) has been tested and meets FCC RF exposure guidelines.

□

This device must not be co-located or operating in conjunction with any other antenna or transmitter. The changes or modifications not expressly approved by the party responsible for compliance could void the user's authority to operate the equipment.



TROUBLESHOOTING

Problem

The  icon is not blinking when the handset is placed on the base

- Bad battery contact – move the handset slightly
- Dirty contact - Clean the battery contact with a cloth moistened with alcohol
- Battery is full – no need to charge

No dialling tone

- No power – check the connections. Reset the phone: unplug and plug back in the main power connector
- Batteries are empty - charge the batteries for at least 24 hours
- You are too far from the base station - move closer to the base station
- Wrong line cable - use the line cable provided
- Line adapter (when needed) is not connected to the line cord – connect the line adapter (when needed) to the line cord

Poor audio quality

- The base station is too close to electrical appliances, reinforced concrete walls or metal door frames - move the base station at least 3 feet away from any electrical appliances

TROUBLESHOOTING

The handset display is not available

- Try again by disconnecting and connecting the base station power supply and follow the procedure to register a handset. Remove and replace the handset batteries

...when attempting to add another handset to the base station

- Maximum number of 5 handsets has been reached – unregister a handset in order to register a new one.

... when using a handset

- Base station may be busy with another handset. Wait until it is available.

Noise Interference on your radio or television

- Your base station or charger may be too close to the radio or Television. Move it as far away as possible.

Caller Line Identification service does not work

- Check your subscription with your network operator

No ring tone

- The ring tone is deactivated. Increase the volume.

A phonebook entry cannot be stored

- The phonebook is full. Delete an entry to free memory.



Electric, Magnetic and Electromagnetic Fields (“EMF”)

- (1) XACT Communication manufactures and sells many consumer oriented products which usually, as with any electronic apparatus, have the ability to emit and receive electro-magnetic signals.
- (2) One of XACT's leading Business Principles is to take all necessary health and safety precautions for our products, to comply with all applicable legal requirements and to stay well within the EMF standards applicable at the time of producing the products.
- (3) XACT is committed to develop, produce and market products that cause no adverse health effects.
- (4) XACT confirms that if its products are handled properly for their intended use, they are safe to use according to scientific evidence available today.
- (5) XACT plays an active role in the development of international EMF and safety standards, enabling XACT to anticipate further developments in standardization for early integration in its products.

CONFORMITY

The Declaration of conformity is available on www.getxact.com.

RECYCLING AND DISPOSAL

Your product is designed and manufactured with high quality materials and components which can be recycled and reused. Do not dispose of your old product with your general household trash.

Inform yourself about the local separate collection system for electrical and electronic products marked by the recycling symbol. Dispose of any batteries at designated collection facilities.





FOR MORE INFORMATION, VISIT XACT AT
www.getxact.com