

Electronic Ballast - Shoplight Series

Product Description

The series electronic ballasts are suitable for shop-light fixtures. It performs rapid start to optimize lamps life. Main specifications are listed below:

- 120V/60Hz
- 2 lamps in parallel
- Middle power factor: >0.50
- Lamp current Crest factor: < 1.7
- End of life protection
- Sound rated A
- UL, cUL recognized

Grantee code: N96

FCC ID: N96-SL2x

Model No: SL2x

Detailed models vs. Lamps

SL26/SL26T	FC12T9 + FC16T9
SL27/SL27T	F17T8 + F17T8 or PLC-13W + PLC13W or PLC-18W + PLC-18W

*Those models with T are potted for outdoor use.

Block diagram

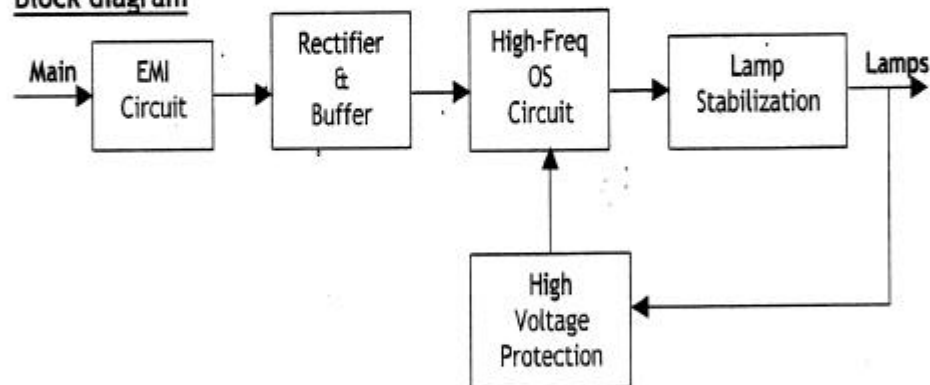

Before Installation

Disconnect line voltage before installing or replacing lamp.
Ballast case must be grounded.

Installation:

Please connect the ballast according to the label on the ballast. Ballast supports only the lamps specified on the product label.

FCC Warning

This equipment has been tested and found to comply with the limits for a Consumer device, Pursuant to Part 18 of the FCC Rules. Operation is subject to the following conditions: (1) this device may not cause harmful interference, and (2) this device must accept any interference received, including interference that may cause undesired operation.

This product may cause interference to radio equipment and should not be installed near maritime safety communications equipment or other critical navigation or communication equipment operating between 0.45-30MHz.