

SUPERCHUTE® DEBRIS REMOVAL SYSTEM

CHUTE HOIST INSTALLATION MANUAL

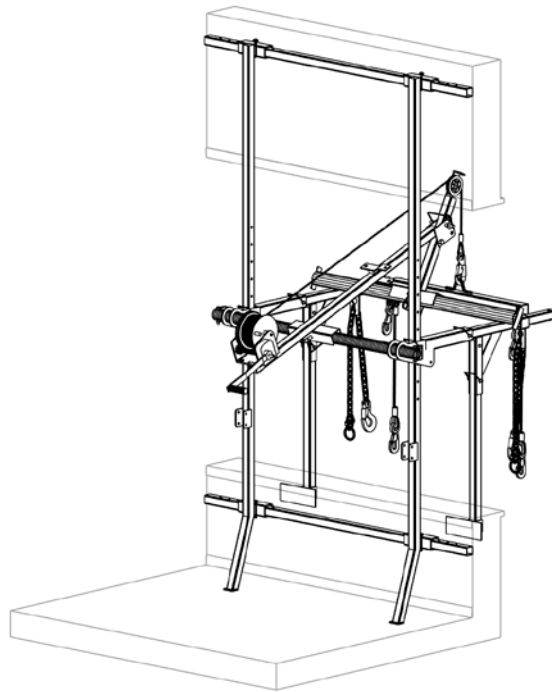

The Loadspreader *For Model N° SC-350-w*

SUPERCHUTE® FACTORY

Edition of Aug 10, 2018

- toll free: 800-363-2488
- telephone: 514-365-6121
- facsimile: 514-365-8987
- internet: www.superchute.com
- e-mail: info@superchute.com
- address: 8810 Elmslie Road, Montreal, Canada, H8R 1V6

**IMPORTANT REFERENCE
DOCUMENT**

IMPORTANT NOTICE:

IT IS THE RESPONSIBILITY OF COMPANIES THAT SELL, RENT OR USE THE SUPERCHUTE® PRODUCT TO FREELY SUPPLY THE LATEST EDITION OF THIS MANUAL TO THE FOLLOWING PERSONS:

- **THE PLANNERS AND SUPERVISORS OF THE CHUTE SYSTEM**
- **THE INSTALLERS OF THE CHUTE SYSTEM**
- **THE USERS OF THE CHUTE SYSTEM**

If you have any questions or comments concerning this manual, please feel free to contact Superchute Ltd.

The contents of this manual remain the intellectual property of Superchute Ltd. Superchute Ltd. authorizes reproduction (photocopies or similar) of all of its safety manuals, provided the reproduction is intended for users of the Superchute® product. Reproductions must be made in their entirety.

*© Superchute Ltd., 1999
All Rights Reserved
Printed in Canada*

This manual refers to the following products, which are protected by international patent laws:

Door Sections	Wraparound® Regular Sections	Chute Hoists
U.S. Pat. No. Des. 328,174 Can. Ind. Des. 1990 RD 66842	U.S. Pat. 5,472,768 Can. Pat. 2,119,108 U.K. Pat. 2,276,151	U.S. Pat. 5,934,437 Can. Pat. Application 2,177,741



WARNING

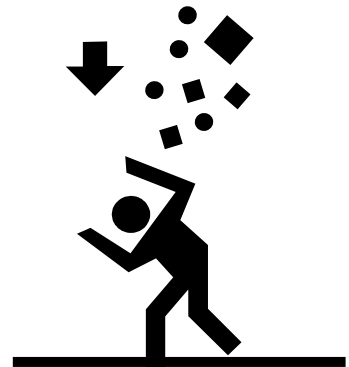
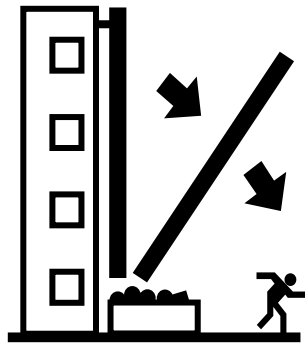
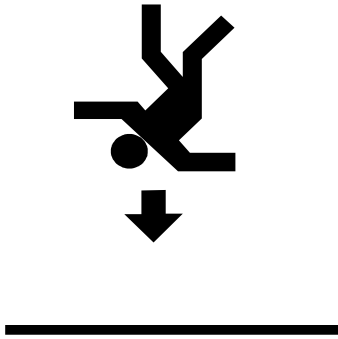

- The installation and use of a Superchute Chute System involves many hazards, for example, the risk of:
 - a worker falling off a building
 - a blockage in the chute causing the chute system to collapse
 - a person being struck by falling debris
- Failure to follow Superchute's instructions may result in serious injury or death.
- Planners, Supervisors, Installers, and Users must read, understand, and follow the instructions found in these manuals before rigging or using a chute system:
 1. The "Chutes Manual"
 2. The applicable "Chute Hoist Installation Manual(s)"
- For copies of these manuals contact Superchute® Ltd: **1-800-363-2488**
or download them from www.superchute.com

HOW TO USE THIS MANUAL

Many people read this manual from beginning to end when they first receive their chute hoist. The manual explains the hoist's features and the procedures for using it safely.

In this manual, you'll find that pictures and words work together to explain things quickly.

A) USE THE MOST RECENT EDITION

- Each new edition of the SC-350-w Chute Hoist Installation Manual contains important new information.
- **ALWAYS USE THE MOST RECENT EDITION:** Compare the edition date of this booklet (printed at the bottom of every page) to the edition available for download on the Superchute website: www.superchute.com. Use the edition with the most recent date. If you do not have access to the internet, call Superchute (1-800-363-2488) and ask a representative for assistance.
- The instructions in a new edition supersede any instruction found in a prior edition.
- Avoid confusion: discard any old SC-350-w Chute Hoist Installation Manuals.

B) IF USING THIS MANUAL EDITION WITH AN OLDER HOIST

Over time, improvements have been made to the Loadspreader Hoist. If you are using this manual with an older hoist, you may find some of the sketches do not match the product you have. If you are unsure of how to proceed, call the Superchute® Factory: 1-800-363-2488.

Older hoists can be upgraded to reflect the latest improvements. Contact the Superchute® factory for details.

C) USE THE TABLE OF CONTENTS

A good place to look for what you need is the Table of Contents located on **page 6** of the manual. It's a list of all that's in the manual along with the page number where you'll find it.

D) SAFETY WARNINGS AND SYMBOLS

You will find a number of safety warnings in this book. Safety warnings tell you about things that could hurt you, or others, if you were to ignore the warning. We use the following symbol to attract your attention to the warning:



A warning indicates a potentially hazardous situation which, if not avoided, could result in death or serious injury.

Here is an example of a Superchute® warning:

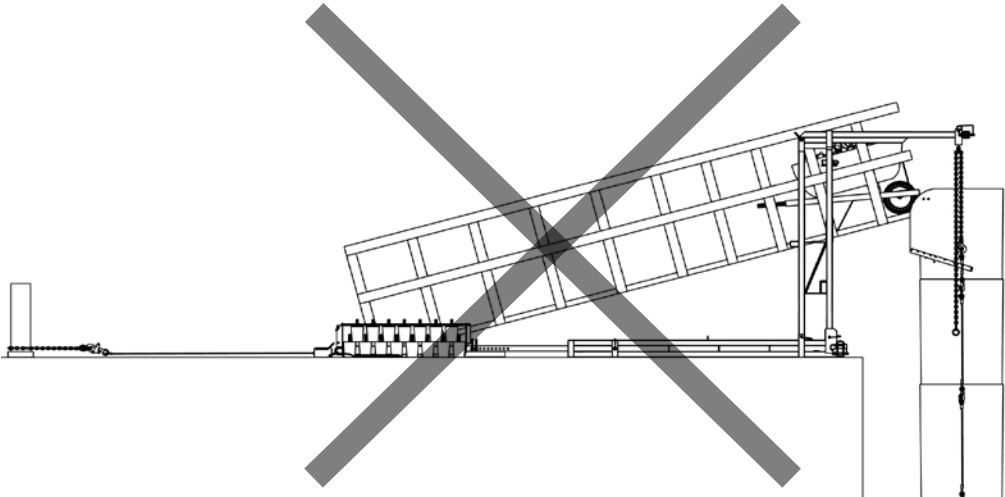
		 WARNING
Hazard	<input type="checkbox"/>	<ul style="list-style-type: none">• A ramp resting on the hoist frame could greatly increase the loading on the hoist frame.• The load increase could cause the hoist frame to fail.• Do NOT rest ramps on the hoist frame. Do NOT attach ramps to the hoist frame. Ramp designs must be approved by a structural engineer.
Consequence	<input type="checkbox"/>	
Instruction	<input type="checkbox"/>	
Pictorial (optional)	<input type="checkbox"/>	<p><u>WRONG:</u></p> <p>The wheelbarrow ramp increases the load on the hoist frame.</p> 

E) STORE THE MANUAL IN THE SUPERCHUTE DOCUMENTS CANISTER

Use a canister at the jobsite to:

- protect and store the manual.
- make the manual readily available to users of the Hoist.

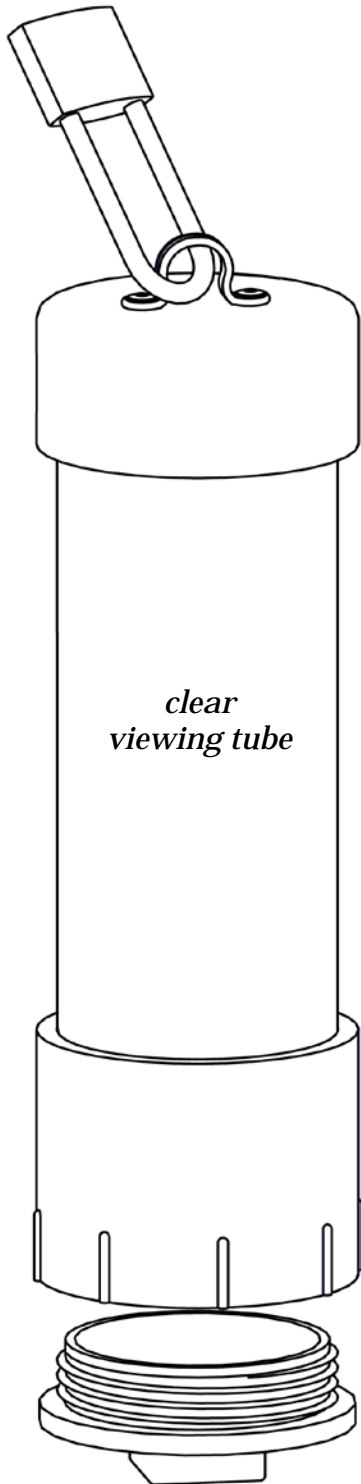

The canister is virtually indestructible and weatherproof. It features a clear plastic viewing tube that allows users to see its contents. The canister is supplied with a brass padlock to allow it to be locked to the hoist.

An on-site canister protects your workers and your company by ensuring greater jobsite safety. Use the canister as part of your overall safety program.

Color pictures with more explanations are provided on the Superchute website: www.superchute.com.

TABLE OF CONTENTS

WARNING	2
HOW TO USE THIS MANUAL.....	3
1. INTRODUCTION.....	7
2. IDENTIFY THE PIECES	8
3. DIMENSIONS.....	11
4. NORMAL LOADS	12
5. ULTIMATE LOADS	12
6. IMPORTANT INFORMATION	13
7. ASSESS CHUTE HEIGHT & WEIGHT	16
8. CHUTE SECTION WEIGHT CHARTS	18
9. A FEW FALL PROTECTION REGULATIONS	19
10. ASSEMBLE THE FRAME.....	20
11. MAST EXTENSIONS.....	24
12. INSTALL THE BOOMS	26
13. INSTALL THE INNER PIPE	29
14. PREPARE THE FISHPOLE (IF APPLICABLE)	30
15. INSTALL THE FISHPOLE (IF APPLICABLE)	32
16. RAISE THE CHUTE SECTIONS.....	37
17. TRANSFER THE CHUTE LOAD FROM THE LIFTING DEVICE TO THE BOOM CHAINS	42
18. REMOVE THE FISHPOLE (IF APPLICABLE).....	44
19. CONGRATULATIONS!	46
20. FALL PROTECTION & THE GATEKEEPER	47
21. DISMANTLE THE CHUTE & HOIST.....	48
22. STORE THE HOIST AS FIVE PACKETS:	52
APPENDIX A: WARRANTY	53
APPENDIX B: STAY INFORMED.....	53
APPENDIX C: PARTS LIST & FACTORY CERTIFICATE.....	54
APPENDIX D: GLOSSARY	55
APPENDIX E: WINCH INFORMATION (IF APPLICABLE).....	56

1. INTRODUCTION

Welcome to safer, quicker, and easier chute installations!

The Superchute® Loadspreader is a chute hoist that mounts to the window of a structurally adequate wall. The wall's exterior must be faced in brick or stone. The advantage of this hoist is its ability to support a chute load without the need for anchor bolts or counterweights.

Superchute Ltd. manufactures two models of Loadspreader: the SC-350-w and the SC-600-w. This installation manual concerns model SC-350-w, which can raise, support, and lower up to 350 lb. of chute. The length of chute that can be created depends on the diameter of chute to be used, and must be calculated (refer to **Section 5** in this manual entitled: **Assess Chute Height & Weight**).

The entire unit assembles in 10 minutes with just a few locking pins. No tools are needed. The design features a 3:1 safety factor.

A removable Fishpole is available for lifting and lowering the chute. A single Fishpole can serve many SC-350-w frames.

When not in use the entire Loadspreader folds into 5 neat, compact packets. Each packet can easily be carried by one fit man.

Understand the Name:

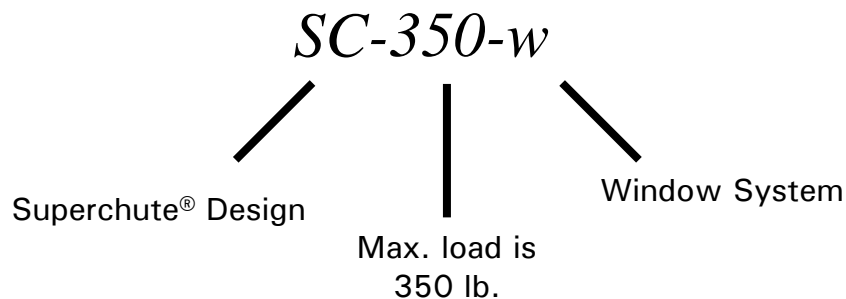

U.S. Pat. 5,934,437

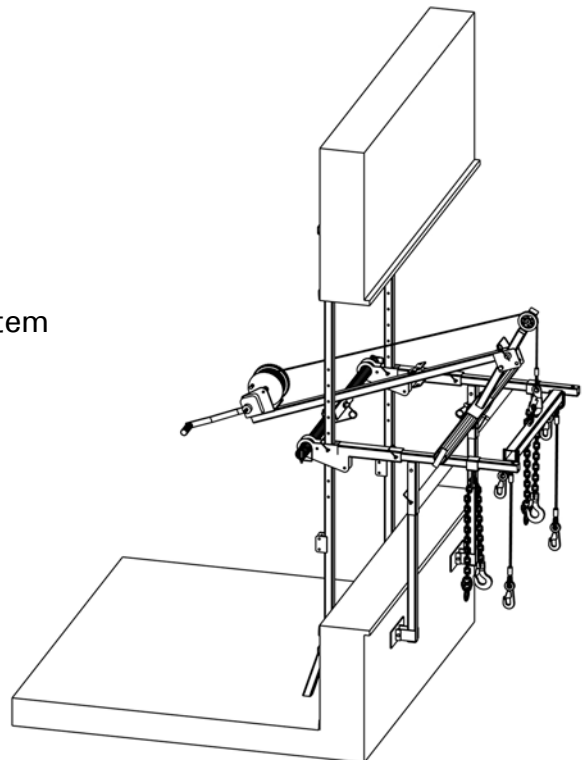

2. IDENTIFY THE PIECES

Frame Components

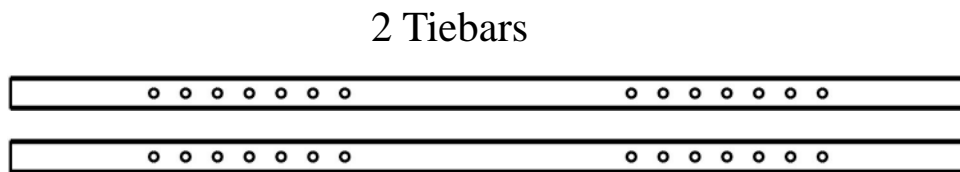
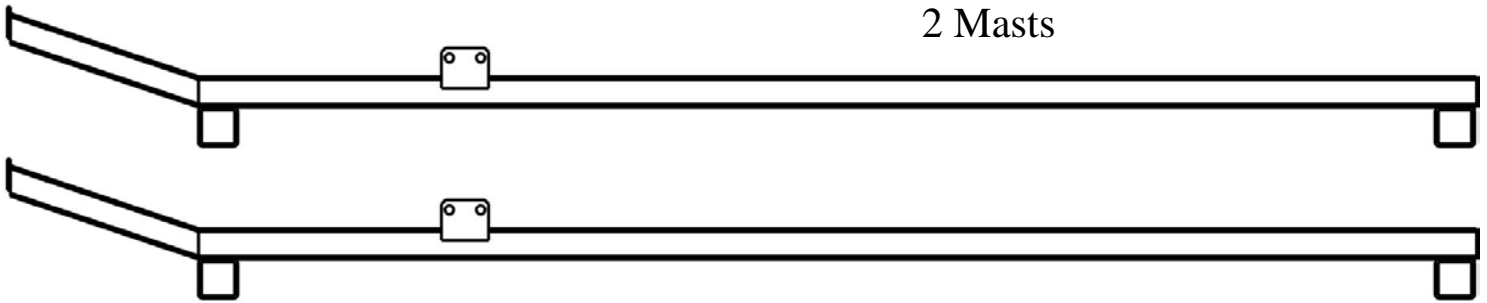

2 Boom Tails

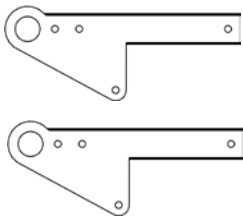

2 Boom Packets

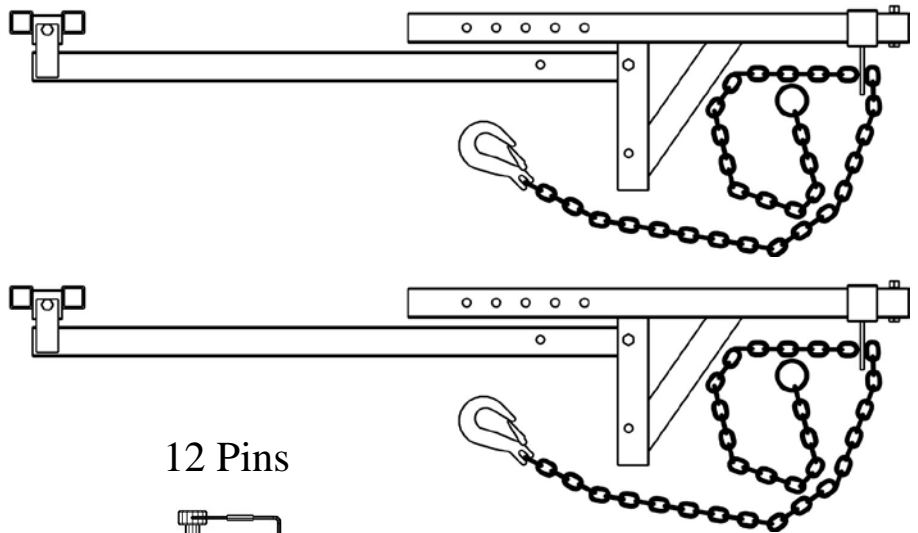

12 Pins

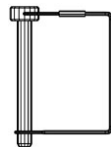

2 Mast Extensions + 4 Pins
(special order)

*Use only with the 7'8" tall masts.
The extensions add 16" in height.*

1 Inner Pipe

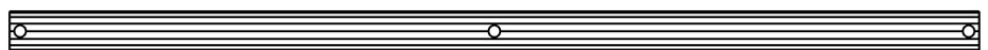

Hoisting Components

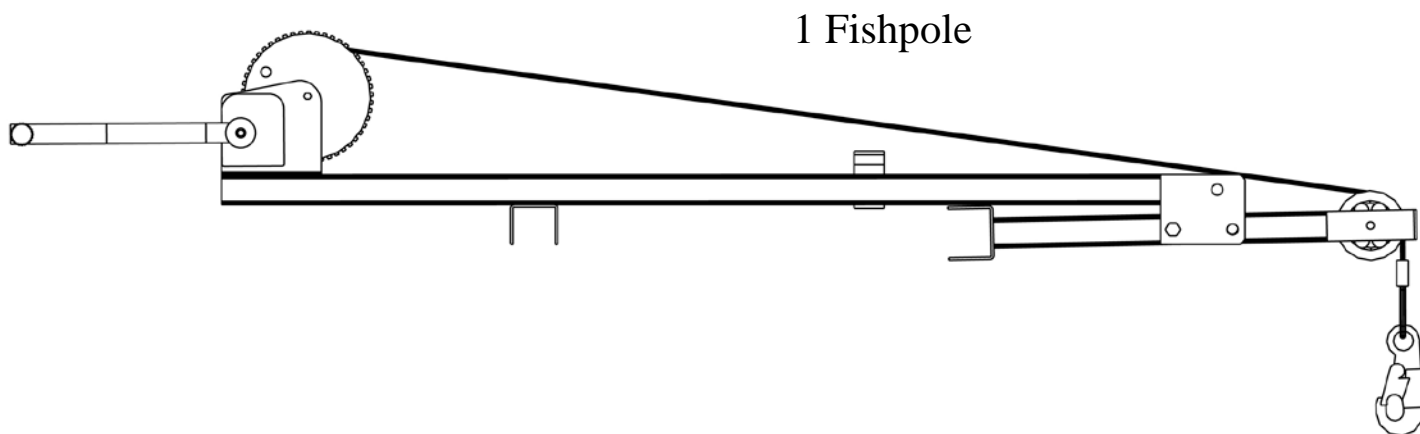

1 Outer Pipe

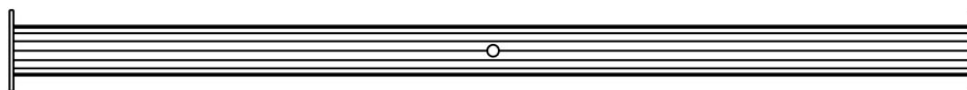

1 Spreader Bar

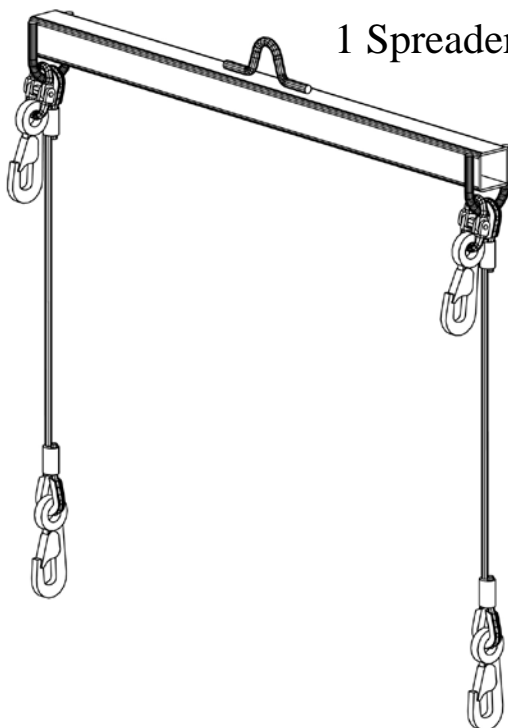

3 Pins

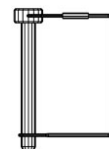

Exploded View

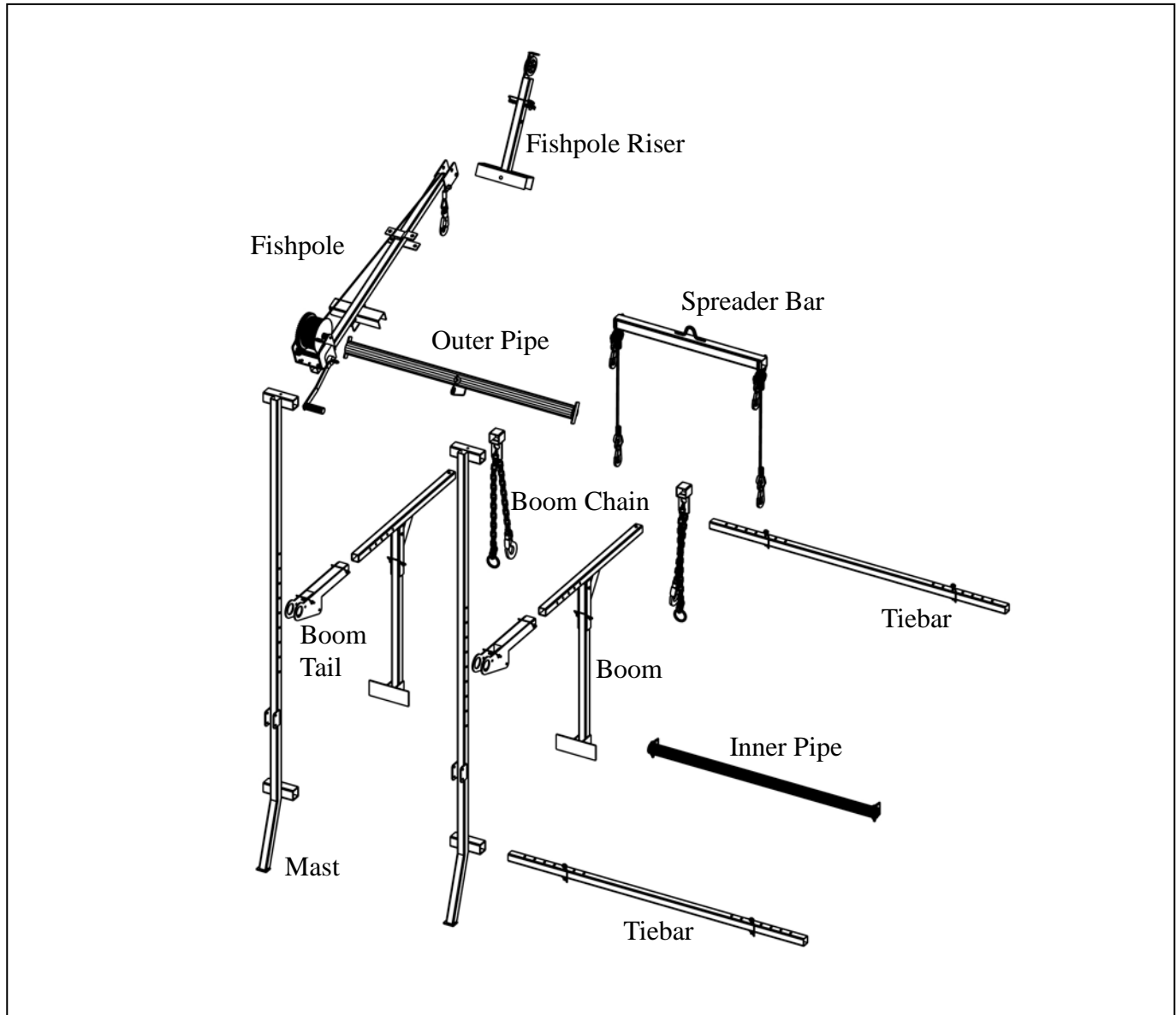

3. DIMENSIONS

- Frame Weight: 100 lb.
- Fishpole Weight: 67 lb.
- Total Weight: 167 lb.

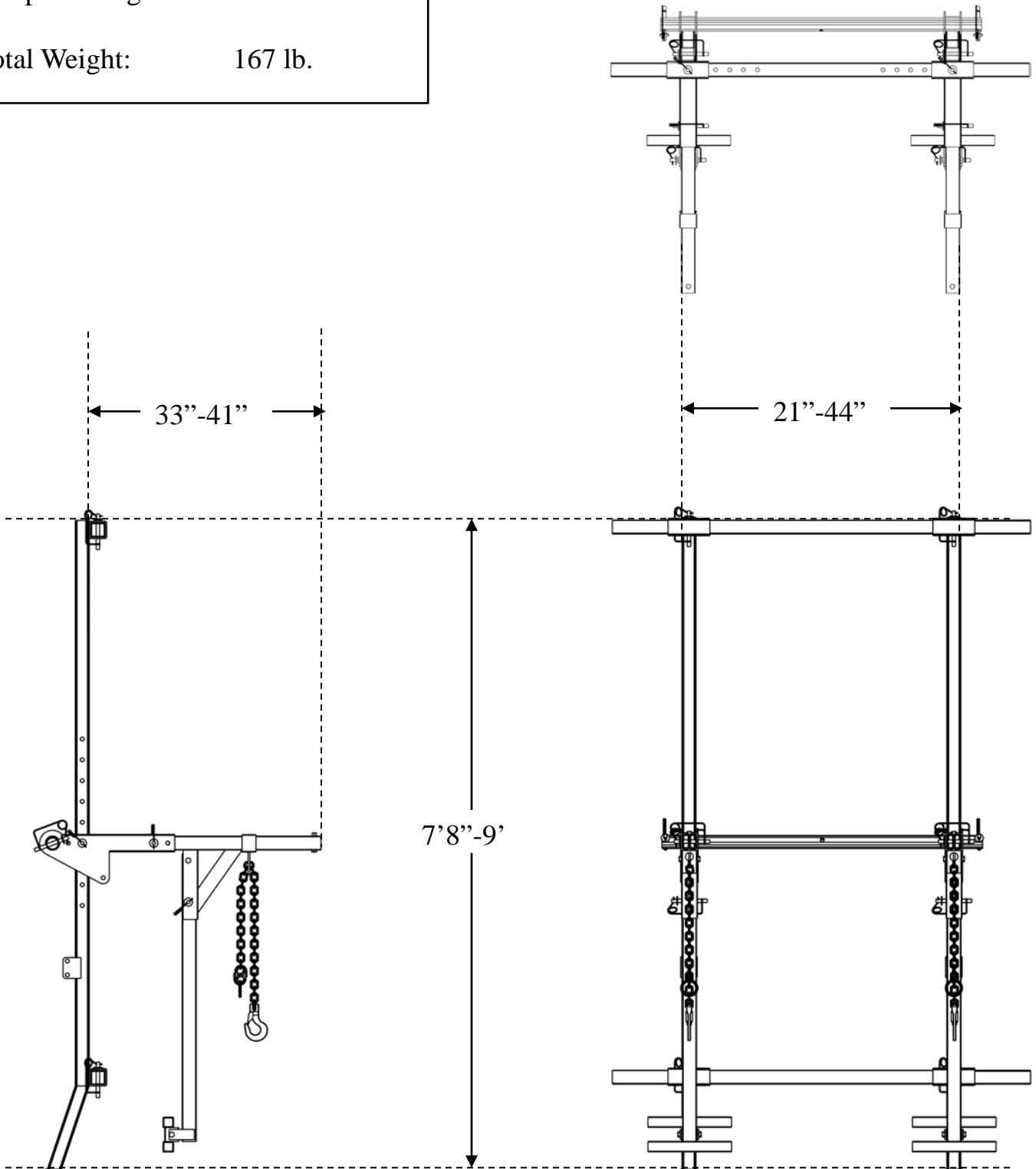

4. NORMAL LOADS

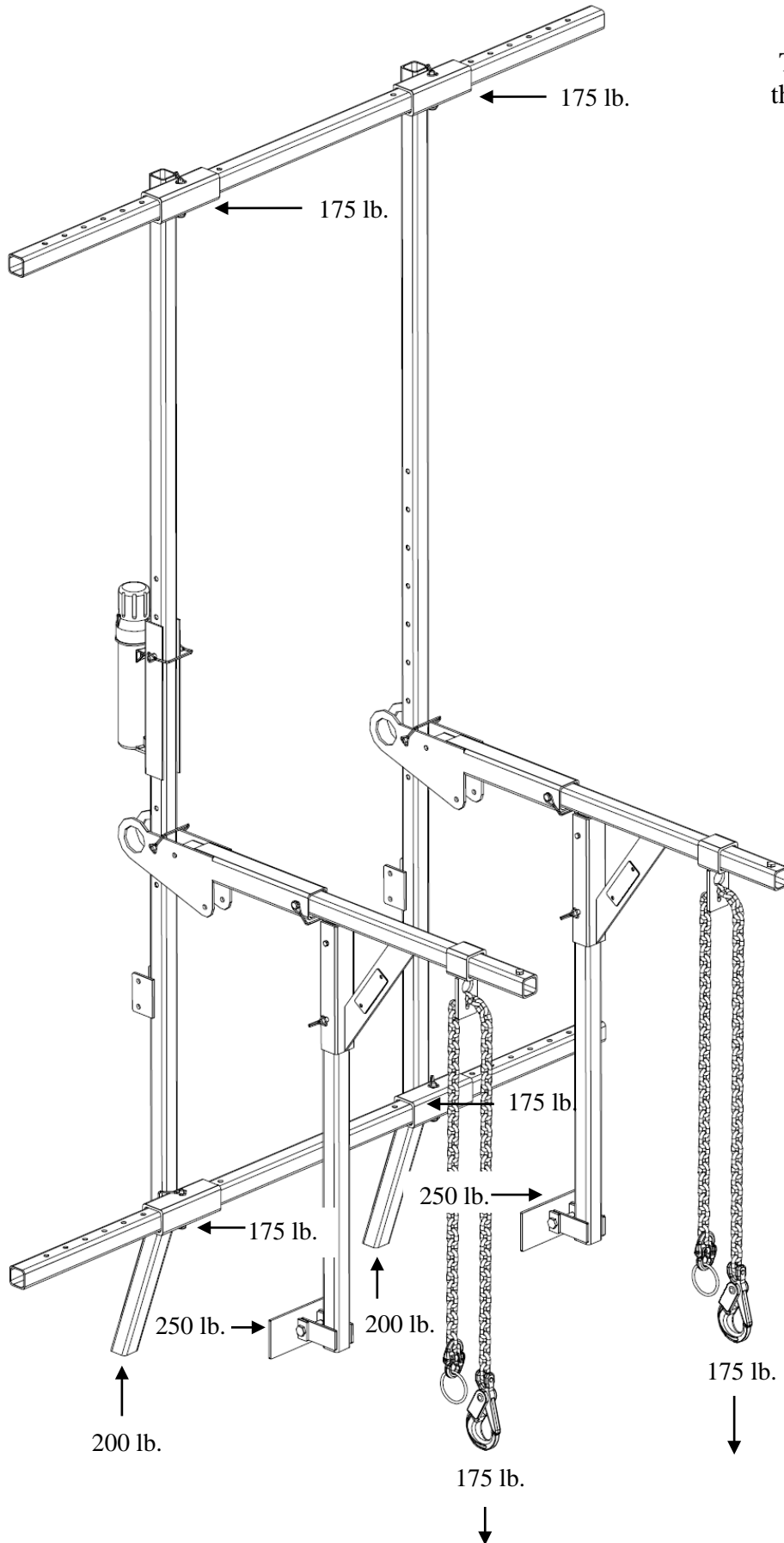

The sketch shows the loads imposed on the supporting structure with normal use.

A structural engineer must verify the adequacy of the supporting structure.

Showing Normal Applied Loading

Maximum Suspended Load
350 lb.
(Shared equally over 2 booms)



175 lb.
↓

5. ULTIMATE LOADS

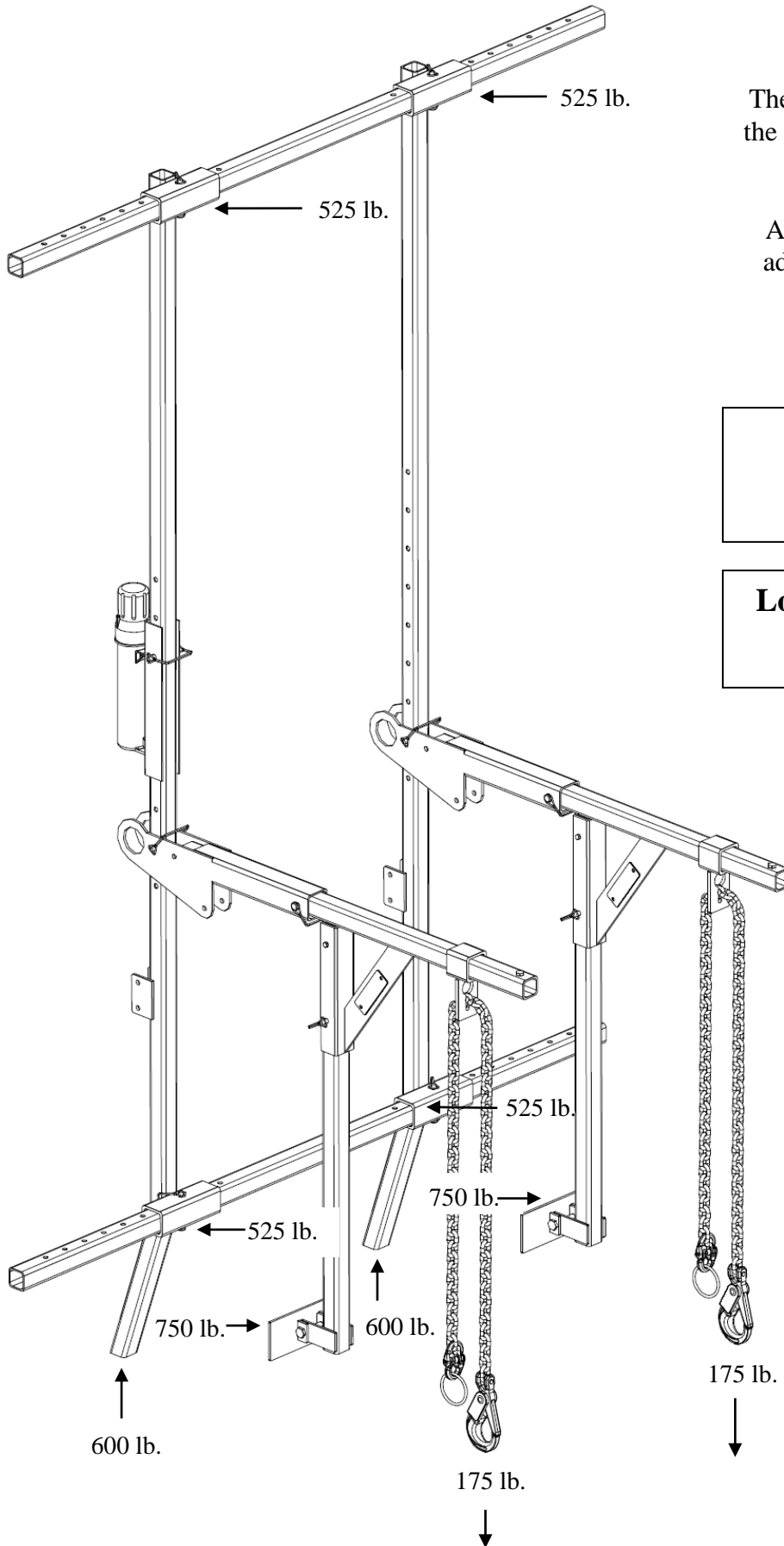

The sketch shows the loads imposed on the supporting structure when the device is overloaded.

A structural engineer must verify the adequacy of the supporting structure.

Showing Ultimate Load Requirement

Loads Imposed On Structure at 3:1 Stability Factor

Maximum Suspended Load
350 lb.
(Shared equally over 2 booms)



175 lb.
↓

6. IMPORTANT INFORMATION

Applicable Regulations:

Before rigging or using the chute system, planners, supervisors, installers and users should be aware of applicable federal, state, and local safety regulations.

Additional Expertise

This manual should not be taken as an overall survey on rigging technique, fall protection, or structure appraisal. Whenever these considerations arise, the planners, supervisors, installers and users of the chute system should secure the services of trained professionals.

Availability of the Manual:

Planners, supervisors, installers and users of the chute system must be able to refer to this manual at any time. Copies of this manual are available from Superchute Ltd. free of charge, **by mail or fax, and can be downloaded from the Superchute® web site at: www.superchute.com**. If this manual is not with the chute system on the job site, postpone installation and use of the chute system until a manual is obtained.

Condition of the Equipment

Every time the chute is to be rigged or used, make sure the following items are in good condition: Superchute® hoist(s), Superchute® cable assemblies, Superchute® chute sections, Superchute® steel liners, and any other ancillary Superchute® equipment, such as door adjustment kits and tie-back kits. Thorough overhaul servicing is available from Superchute Ltd.

Condition of the Workers

Superchute® equipment should only be used by workers who are fit to operate it in a responsible manner.

Corrosive Substances

Keep corrosive substances away from all hoist components.

Engineered Rigging Equipment

Use engineered rigging equipment to install and anchor chute sections (for example, a Superchute® chute hoist)

Fire Prevention

Do not weld or flame-cut within 20 ft. of the hoist or chute.

Help Line

If at any time you are unsure of how to proceed call Superchute Toll Free: 1-800-363-2488

Intent of the Product

Do not use the chute hoist to lift or lower materials other than a Superchute® trash chute. Do not use the chute hoist as a man-hoist.

Lightning Storm

During a lightning storm stay away from the hoist & suspended chute system.

Other Brands of Chute

Do not mix Superchute® chute sections with chute sections of another brand.

Parts

Do not replace original Superchute® parts with non-Superchute® parts.

Powered loaders

Do not use powered loaders to introduce debris into the chute.

Prevent Electrocution

Install the hoist and chute in an area free of electric cables. If cables are present contact your local electrical authority before proceeding.

Structural Engineer

Before a chute installation begins, a structural engineer must verify the adequacy of the supporting structure.

Training

A one-day training seminar is offered free of charge at the Superchute® factory. The seminar examines the proper installation and use of Superchute® chute sections and chute hoists. Call 1-800-363-2488 for details.

7. ASSESS CHUTE HEIGHT & WEIGHT

EXAMPLE

- The first step in undertaking a chute installation is to formulate an installation plan.
- This page is a planning tool, which is used here to illustrate an imaginary chute job.
- The next page is clean and is for your own use. Photocopy it and use it to plan your chute installations.

JOB NAME: Hotel On First Ave.

1. What is the anticipated height of the chute? 26' feet.

26 feet x 3 divided by 10 = 7.8

2. How many chute sections will be needed? Height in ft x 3 ÷ 10 = 8 sections.
When linked, 3 chute sections of any type will create a 10 foot drop.

3. What diameter of chute will be used? [18"] [23"] [27"] [30"] [33"] [36"]
Every chute section is branded with its diameter.

4. Calculate the total weight of the chute system using the form below:
Every chute section is branded with its weight.
Section Weights are also provided on [page 16](#).

Chute Weight Calculation Form

(A) 1 Top Hopper x 42 lb. each = 42 lb.
Wraparound

(B) 0 Door Sections x 52 lb. each = 0 lb.
Wraparound

(C) 7 Regular Sections x 39 lb. each = 273 lb.
Wraparound - 3/16" wall

(D) 0 Steel Liners x 40 lb. each = 0 lb.

A+B+C+ D = The Total Weight Of The Chute System = 315 lb.

5. Does this weight exceed 350 lb? If "YES", then model SC-350-w is not adequate.
Call the Superchute® factory if your chute weight will exceed 350 lb.

No. The weight of the chute and liners is 315 lb. which is less than 350 lb.

OK - Proceed!

ASSESS CHUTE HEIGHT & WEIGHT – Photocopy this page

Before the chute is rigged it's height and weight must be calculated. Photocopy this form and use it with the weight charts provided on the next page. Knowing the total weight of the chute allows the installer(s) to choose an appropriate lifting device and suitable anchors. If at any time you would like to discuss the particulars of your job situation, please feel free to call the Superchute® factory: 1-800-363-2488.

JOB NAME: _____

1. What is the anticipated height of the chute? _____ feet.
2. How many chute sections will be needed? Height in ft x 3 ÷ 10 = _____ sections.
When linked, 3 chute sections of any type will create a 10 foot drop.
3. What diameter of chute will be used? [18"] [23"] [27"] [30"] [33"] [36"]
Every chute section is branded with its diameter.
4. Calculate the total weight of the chute system using the form below:
Every chute section is branded with its weight.
Section Weights are also provided on the next page.

Chute Weight Calculation Form

(A)	<u> 1 </u>	Top Hopper	x	_____ lb. each	=	_____ lb.
(B)	_____	Door Sections	x	_____ lb. each	=	_____ lb.
(C)	_____	Regular Sections	x	_____ lb. each	=	_____ lb.
(D)	_____	Steel Liners	x	_____ lb. each	=	_____ lb.
A+B+C+ D = The Total Weight Of The Chute System						= _____ lb.

5. Does this weight exceed 350 lb? If "YES", then model SC-350-w is not adequate.
Call the Superchute® factory if your chute weight will exceed 350 lb.

8. CHUTE SECTION WEIGHT CHARTS

- An “x” signifies that no such section exists.
- If using steel liners, do not forget to account for their weight.

WELDED SECTIONS WEIGHTS (in lb.)

Diameter	Wall Thick.	Regular	Top Hopper	Door
18”	5 mm	23	24	29
23”	5 mm	27	30	36
27”	5 mm	32	34	41
30”	5 mm	37	40	47
30”	4 mm	27	X	X
30”	3.2 mm	X	X	X
33”	5 mm	40	42	50
36”	6 mm	48	53	60

WRAPAROUND® SECTIONS WEIGHTS (in lb.)

Diameter	Wall Thick.	Regular	Top Hopper	Door
18”	5 mm	X	X	X
23”	5 mm	29	30	40
27”	5 mm	35	40	49
30”	5 mm	39	42	52
30”	4 mm	31	X	X
30”	3.2 mm	28	X	X
33”	5 mm	43	48	57
36”	6 mm	49	57	68

LINER WEIGHTS (in lb.)

18”	23”	27”	30”	33”	36”
23 lb.	32 lb.	37 lb.	40 lb.	48 lb.	53 lb.

9. A FEW FALL PROTECTION REGULATIONS

“The employer shall determine if the walking/working surfaces on which its employees are to work have the strength and structural integrity to support employees safely. Employees shall be allowed to work on those surfaces only when the surfaces have the requisite strength and structural integrity.”

“Each employee on a walking/working surface ... with an unprotected side or edge which is 6 ft or more above a lower level shall be protected from falling by the use of guardrail systems, safety net systems, or personal fall arrest systems.”

“An unprotected side or edge means any side or edge ... where there is no wall or guardrail system at least 39” high.”

“Each employee in a hoist area shall be protected from falling 6 feet or more to lower levels by guardrail systems or personal fall arrest systems. If guardrail systems ... or portions thereof, are removed to facilitate the hoisting operation ... and an employee must lean through the access opening or out over the edge of the access opening (to receive or guide equipment and materials, for example) that employee shall be protected from fall hazards by a personal fall arrest system.”

From OSHA Part 1926 Safety and Health Regulations for Construction, Subpart M, Fall Protection

For a more complete understanding of the OSHA Regulations you can:

- Consult OSHA’s excellent online documentation on the internet: www.osha.gov.
- Telephone the OSHA bookstore (206) 553-4270 and order the OSHA Regulations on CD-ROM (price \$53).
- Telephone the OSHA bookstore (206) 553-4270 and order **29 CFR Part 1926** in print (price \$30).
- Some states have their own regulations, which will differ from the U.S. Dept. of Labor’s OSHA regulations.

10. ASSEMBLE THE FRAME



WARNING

- A person can easily fall off of a building if the floor edge they are working near does not offer fall protection safeguards.
- A fall from a height of 6 ft. is enough to seriously injure or kill.
- OSHA requires that fall prevention barriers be at least 42” high, plus or minus 3”. Guardrail systems, parapet walls, and window sills may be acceptable fall prevention barriers provided they meet OSHA’s height criteria.
- Use a personal fall arrest system (body harness and lanyard, or similar device) when working near a floor edge that does not offer proper fall prevention barrier(s).
- Read and understand the OSHA fall protection regulations (a few of the regulations are provided on the previous page).

- Start with two Mast packets.

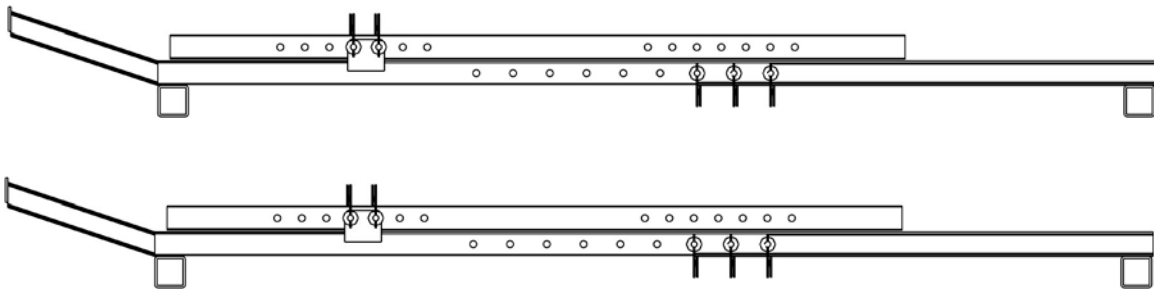



WARNING

- The frame may fail when load is applied if the correct pins are not used.
- A falling load can seriously injure or kill.
- Use only the pins that were supplied with this hoist (see “Pin Info” below).
- To prevent pin loss, store the pins on the unit.
- Order replacement pins from Superchute Ltd.

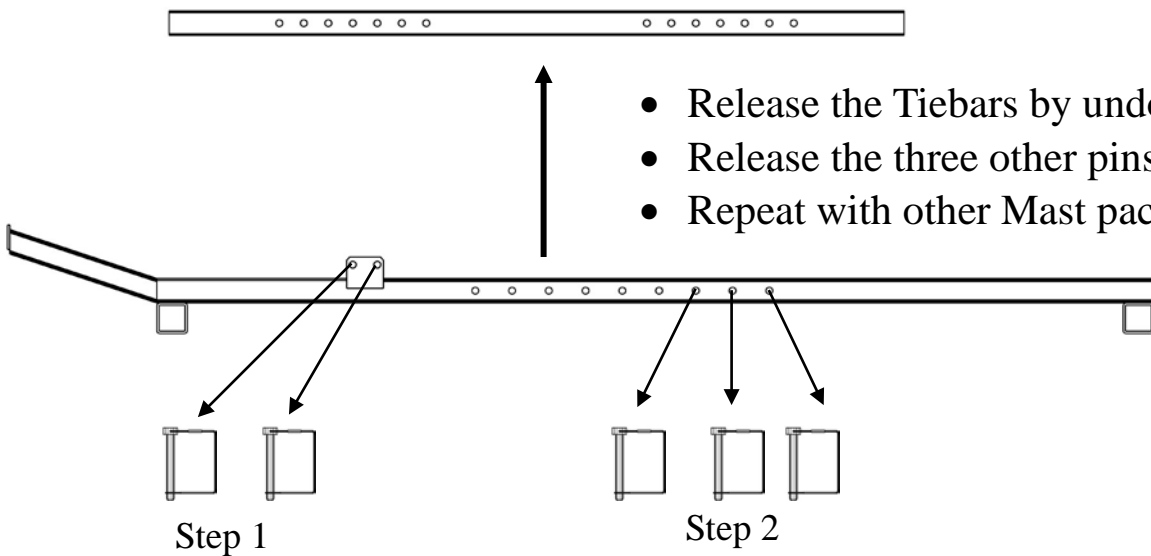

Pin Information:

- 12 pins are required to assemble and use the FRAME.
- 3 pins are required to assemble and use the FISHPOLE.
- 2 spare pins are provided with every frame.
- All of the pins used on the SC-350-w are identical:

- Diameter: 5/16"
- Overall Length: 3"
- Usable Length: 2½"

- Lean two Masts against the wall.
- The window opening must be at least 5" wider than the chute diameter.

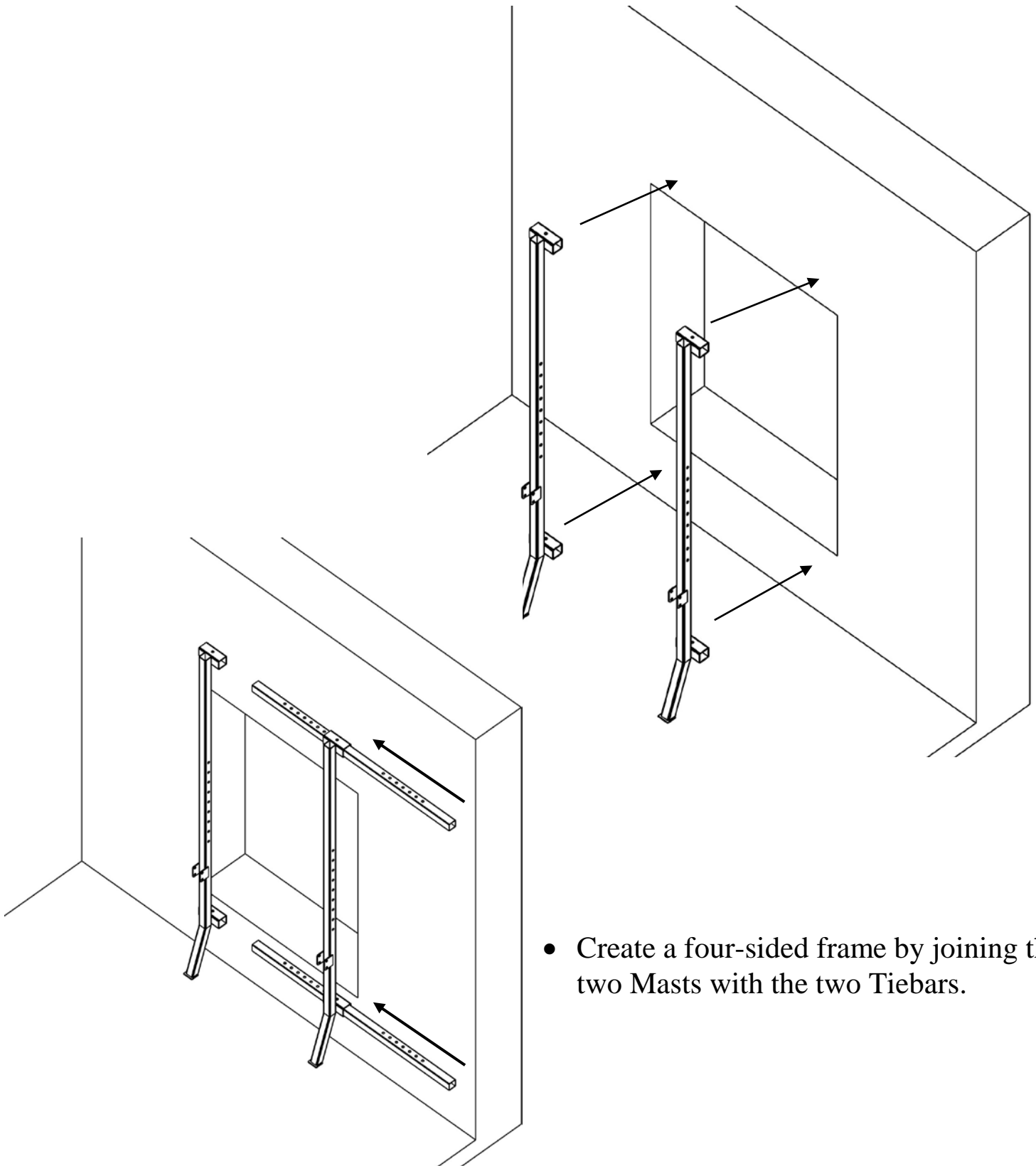

- Create a four-sided frame by joining the two Masts with the two Tiebars.

- Pin the Tiebars in place.
- Use 4 pins.

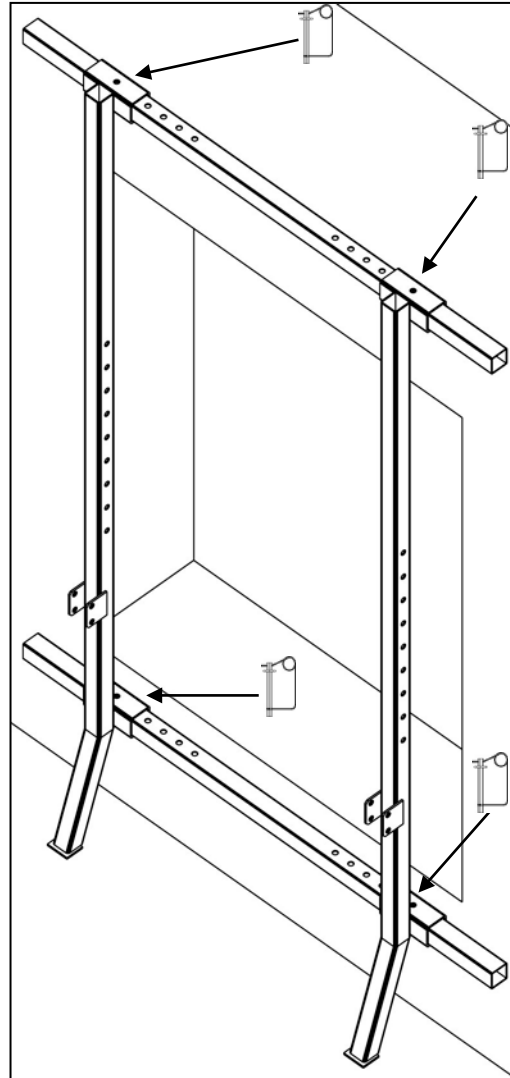

WARNING

- If the Tiebars do not contact the wall above and below the window, the hoist frame could be pulled through the window when load is applied.
- A falling frame can seriously injure or kill.
- The Tiebars must rest against the wall above and below the window. If they do not, the SC-350-w hoist is not appropriate for the job.

11. MAST EXTENSIONS

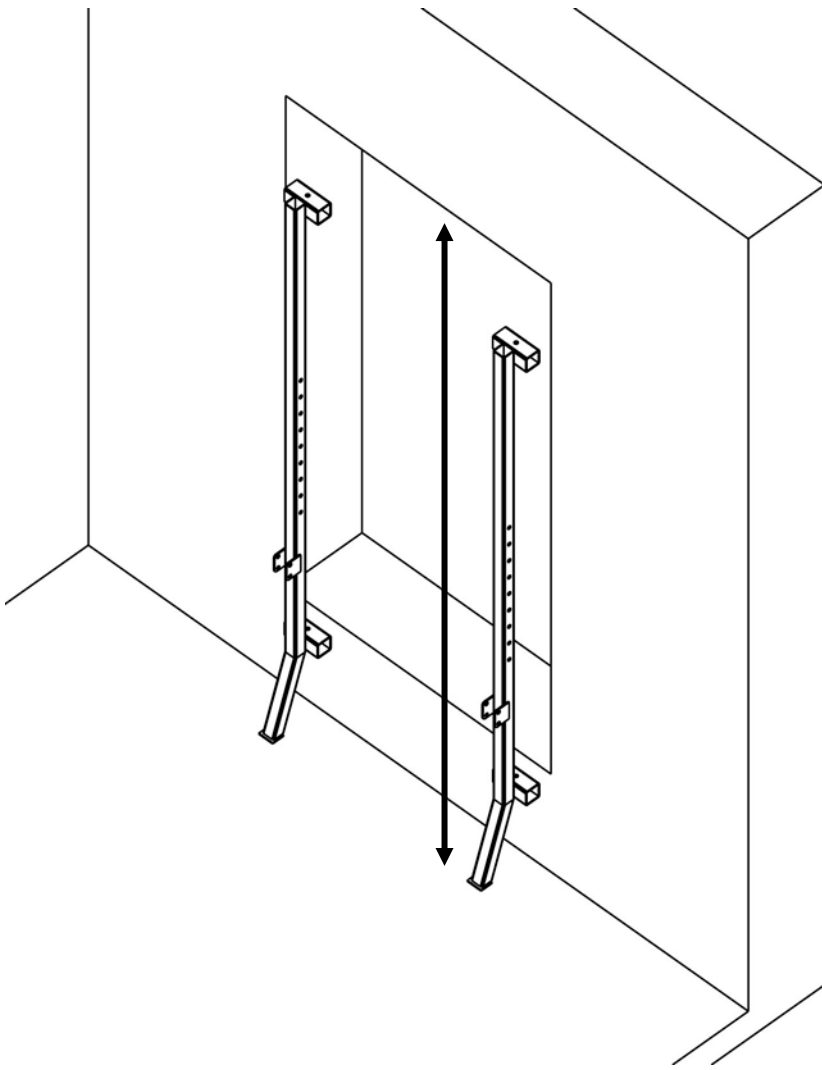

- Mast Extensions are available for purchase.
- They will increase the height of 7'8" Masts to 9 feet.
- 9 ft. tall Masts are available for purchase. Mast Extensions must not be used on the 9 ft. Masts.

- The following sketches show the attachment of the Extensions.

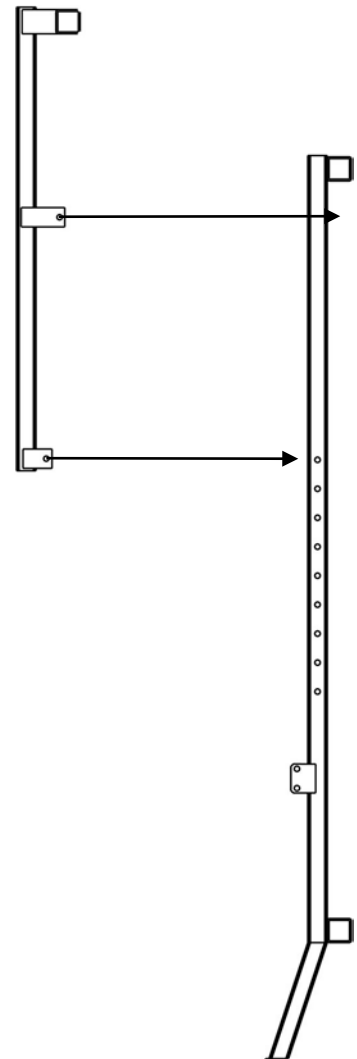

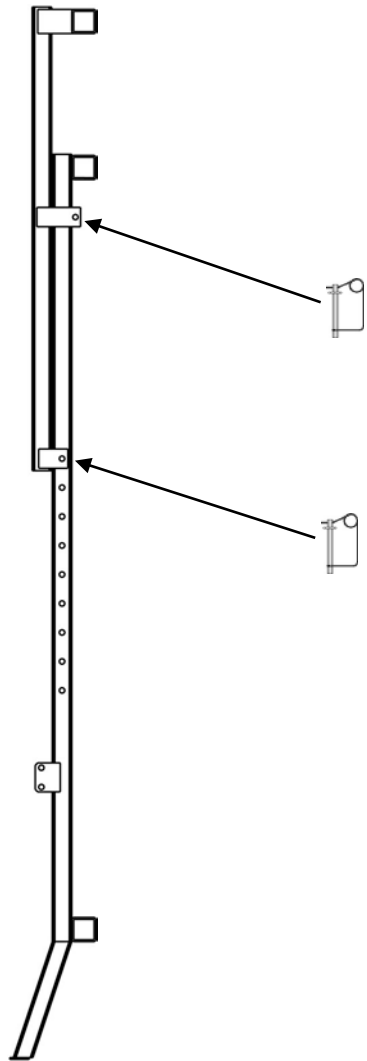

- Pin the Extensions as shown.

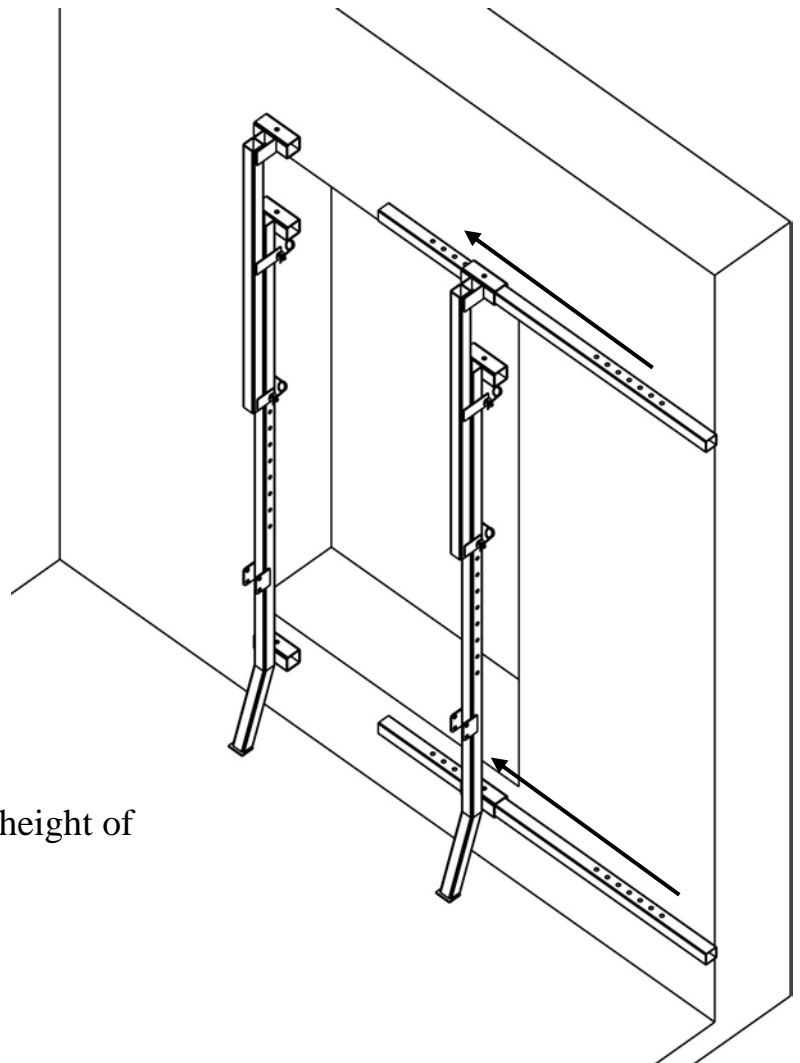

- The Extensions increase the height of the upper Tiebar.

12. INSTALL THE BOOMS

- Release the two pins on each Boom packet.

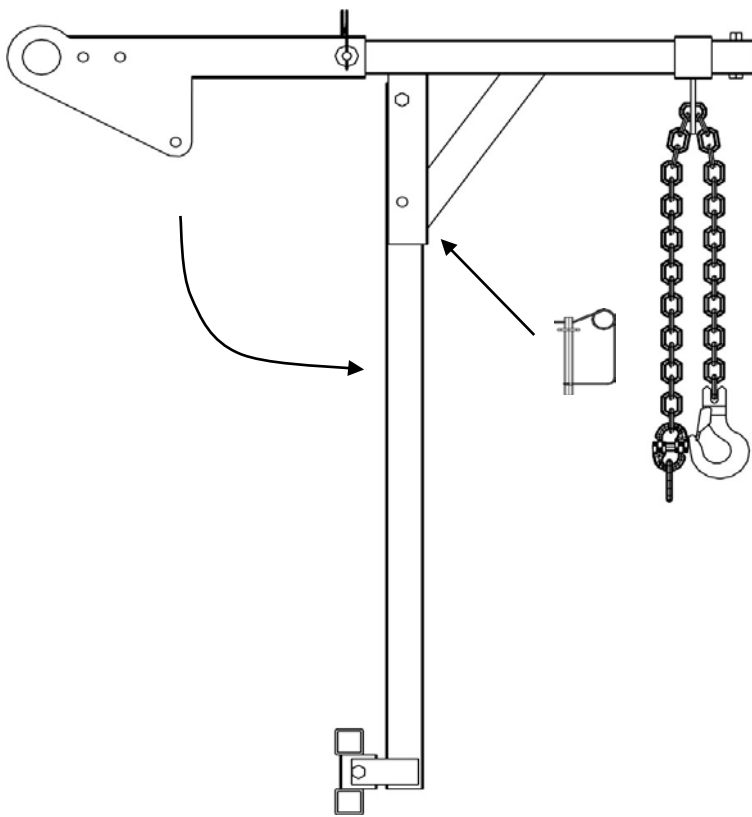
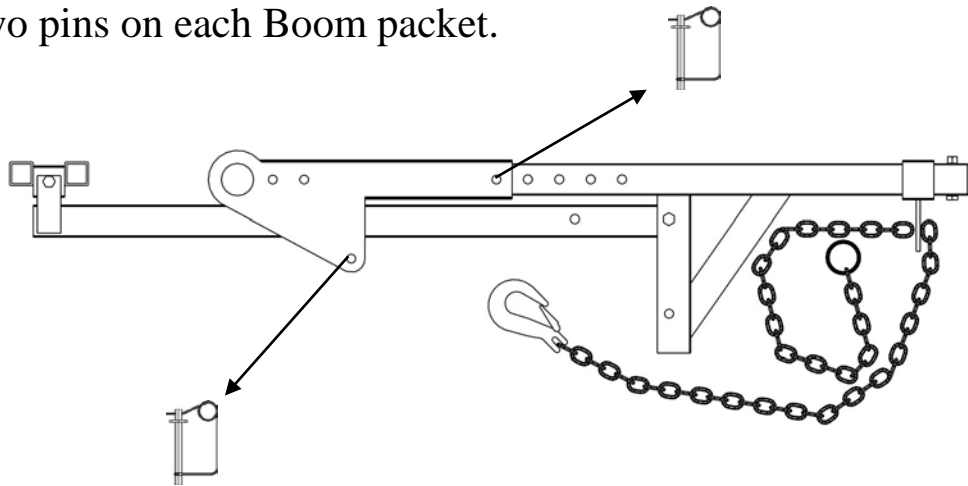

- Unfold the Boom.
- Pin Boom Leg in place.

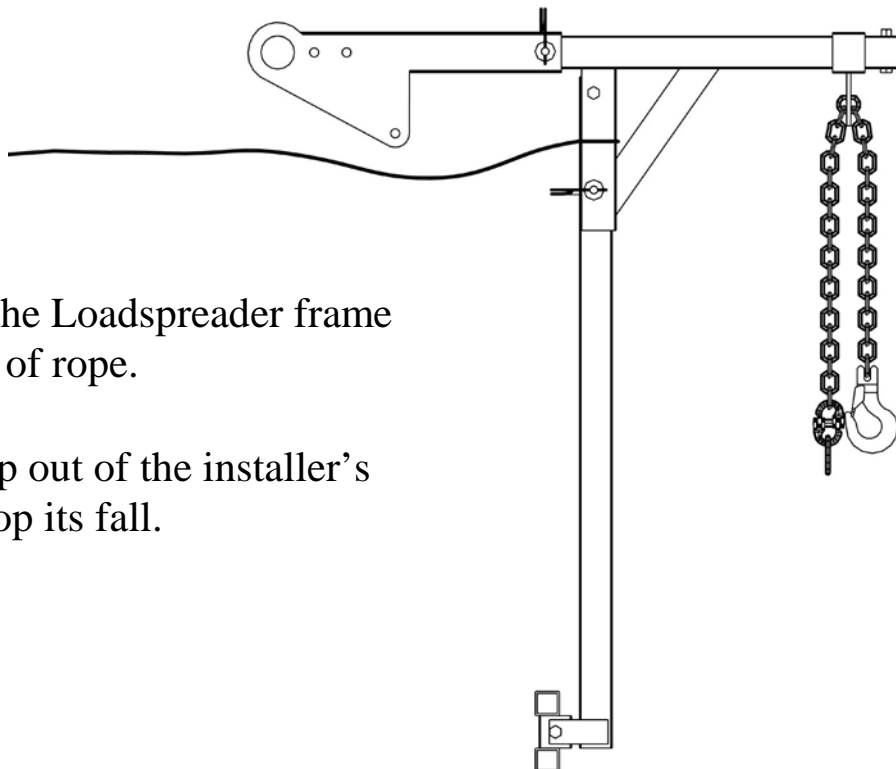

- Secure each Boom to the Loadspreader frame using a six foot length of rope.
- If the Boom should slip out of the installer's hands, the rope will stop its fall.



WARNING

- In the steps shown on the next page, two awkward and heavy booms will be lifted through the window and attached to the frame.
- If the installer loses his balance, he could fall through the window and be killed by the fall.
- Before installing the booms put on a body harness with a lanyard attached to a 5000 lb. capacity anchor.

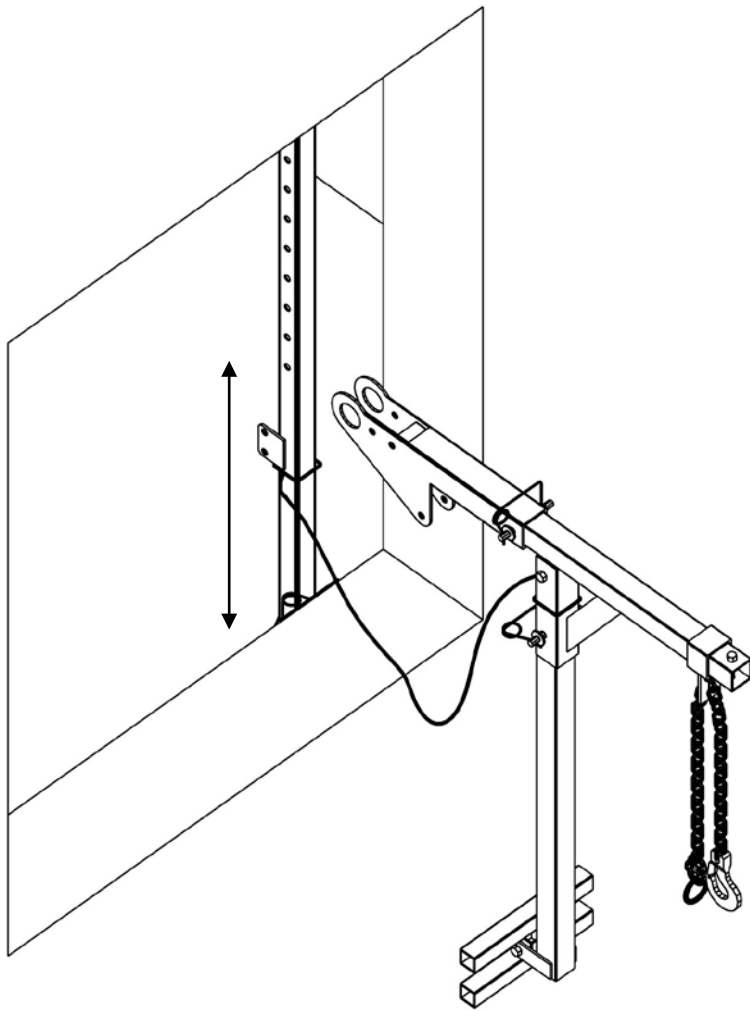

- Lift a Boom through the window and attach it to the Frame.
- Repeat with the other Boom.
- The Booms must both be installed at the same height.
- To facilitate the chute installation, pin the Booms at approximately chest height.

THE MAXIMUM WALL THICKNESS THE LOADSPREADER CAN ACCEPT IS 20".

- Pull the booms towards the building.
- If necessary, lengthen or shorten the Booms (by adjusting the Boom Tails) to accommodate the wall thickness.
- Pin the Booms in position.

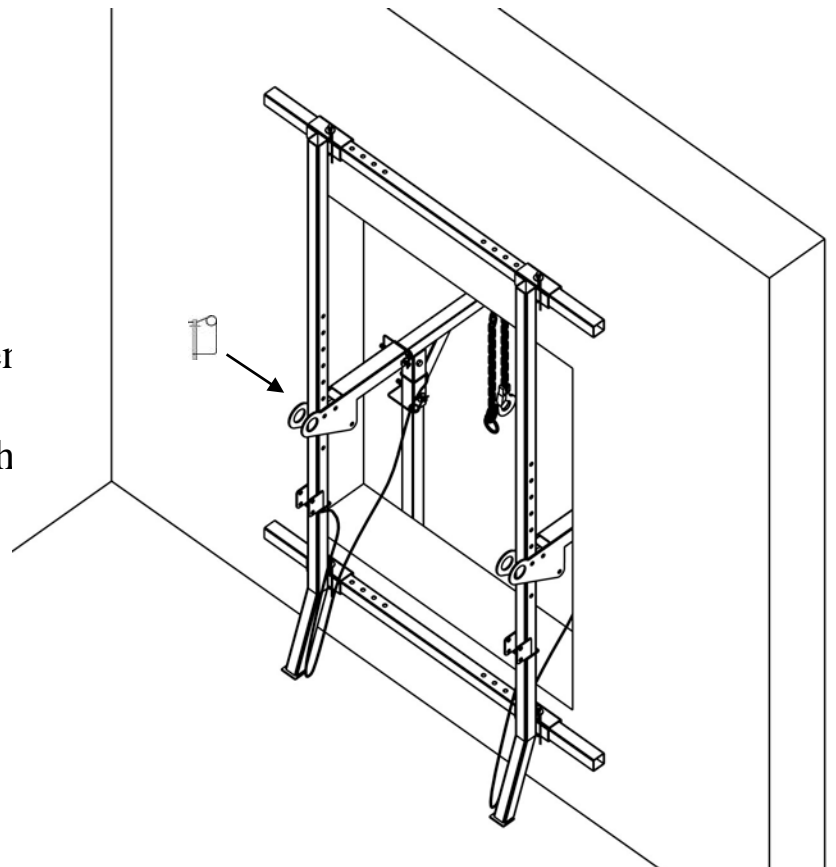

13. INSTALL THE INNER PIPE

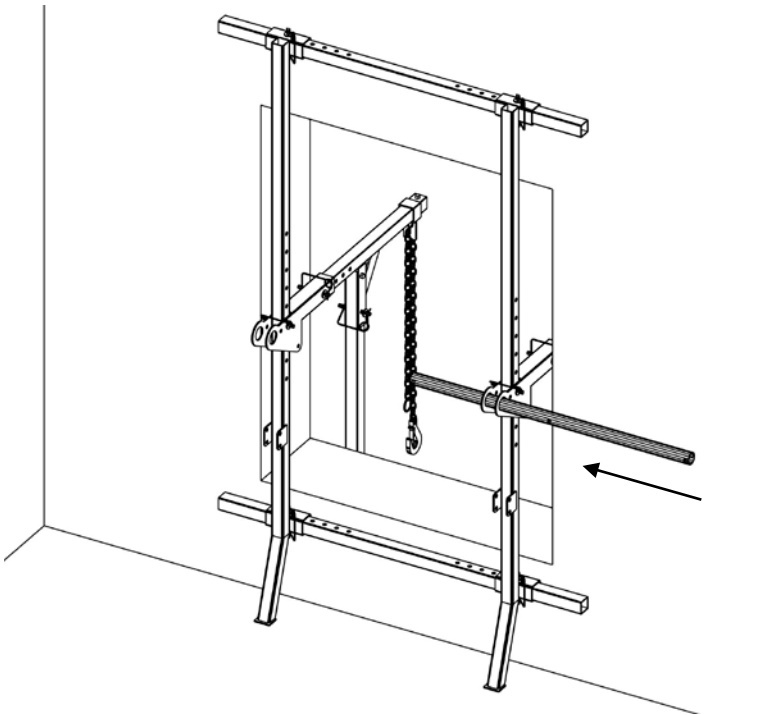

- Pass the Inner Pipe through the Boom Tails.
- The Inner Pipe will be used to support the Fishpole.
- If the window sill is less than 39” high, then the Inner Pipe can also serve as a partial **fall protection barrier**, providing it is installed at a height of 42” plus or minus 3” (OSHA requirement).

- Secure the Inner Pipe with two pins.

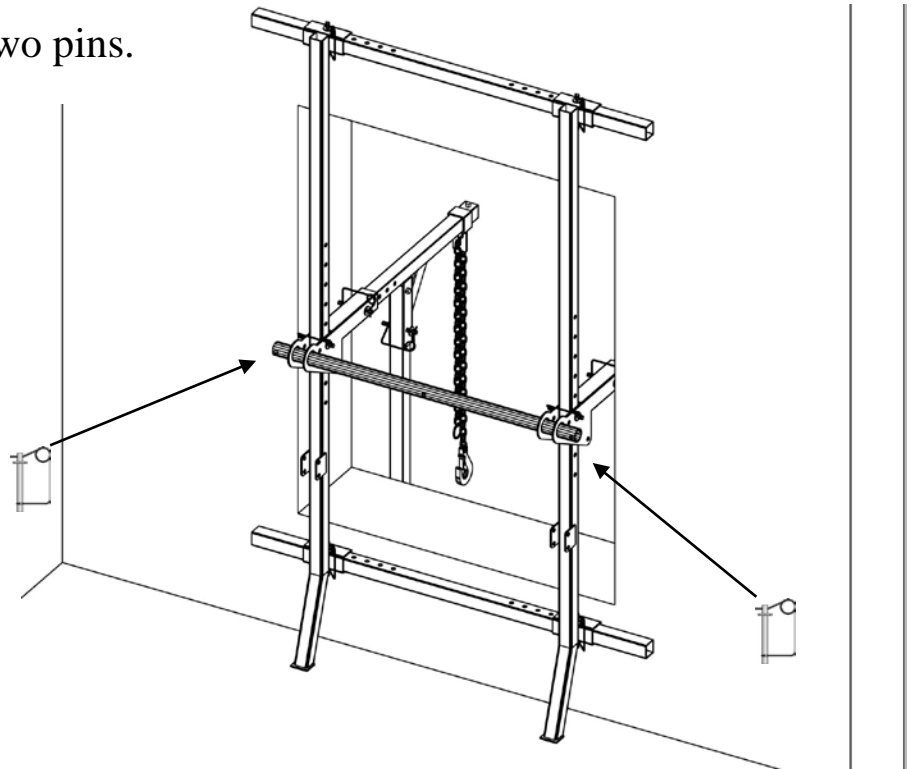

14. PREPARE THE FISHPOLE (IF APPLICABLE)

The Fishpole will be unnecessary if a crane, or similar device, will be used to lift the chute.

*If using a crane, or similar device, then please go directly to **Section 14**.*

- Start with the Fishpole packet.
(The Inner Pipe has already been removed for use in the prior step).

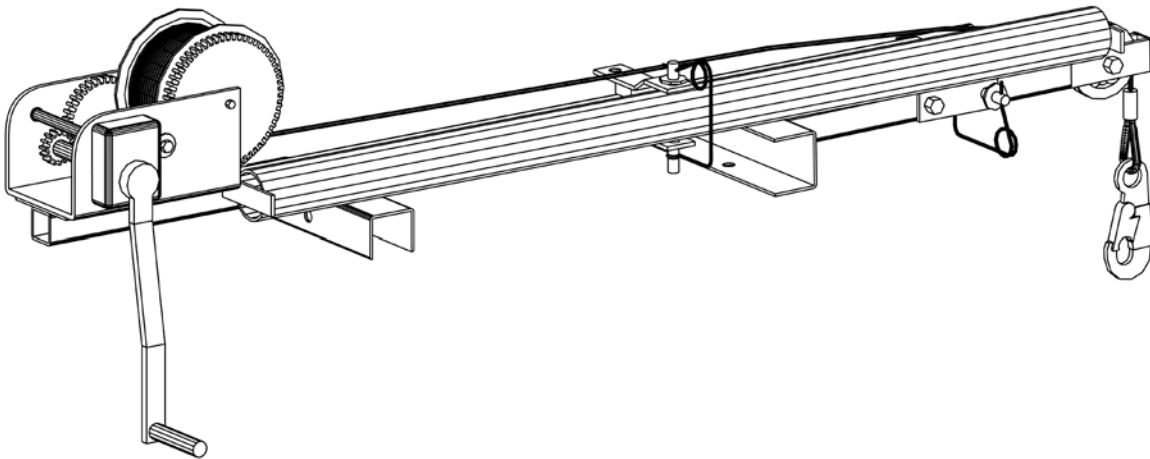

- Release the pin that secures the Outer Pipe
- Release the pin that secures the Fishpole Riser.

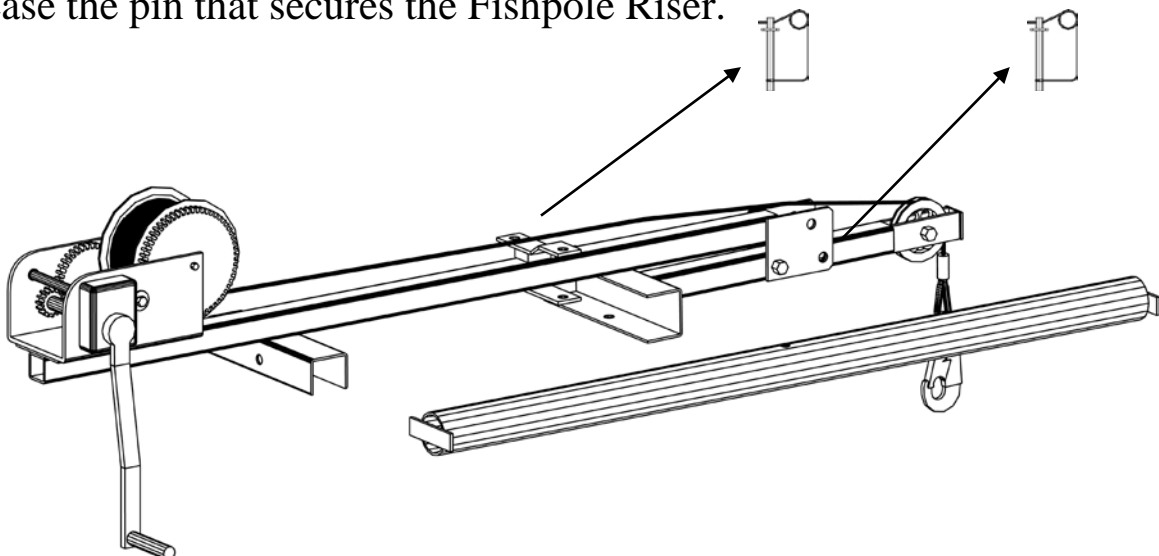

- Pin the Riser in the raised position, as shown below.

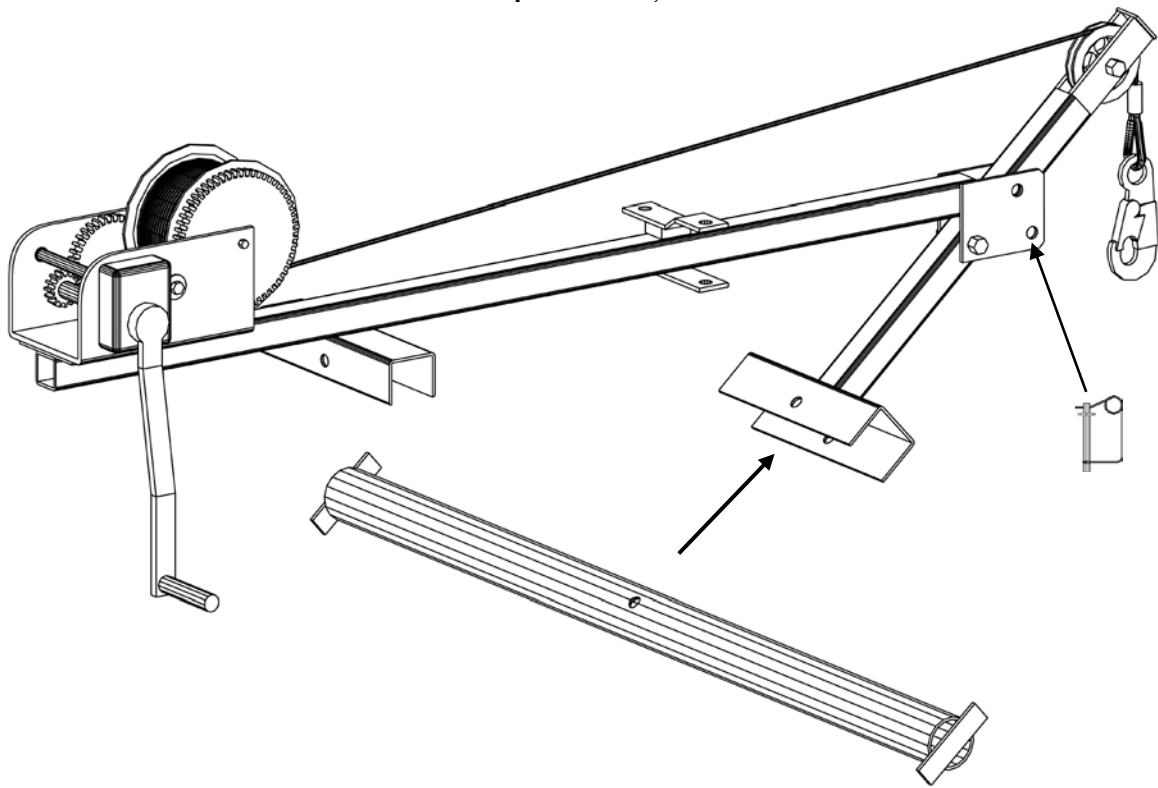

- Pin the Outer Pipe to the Riser.

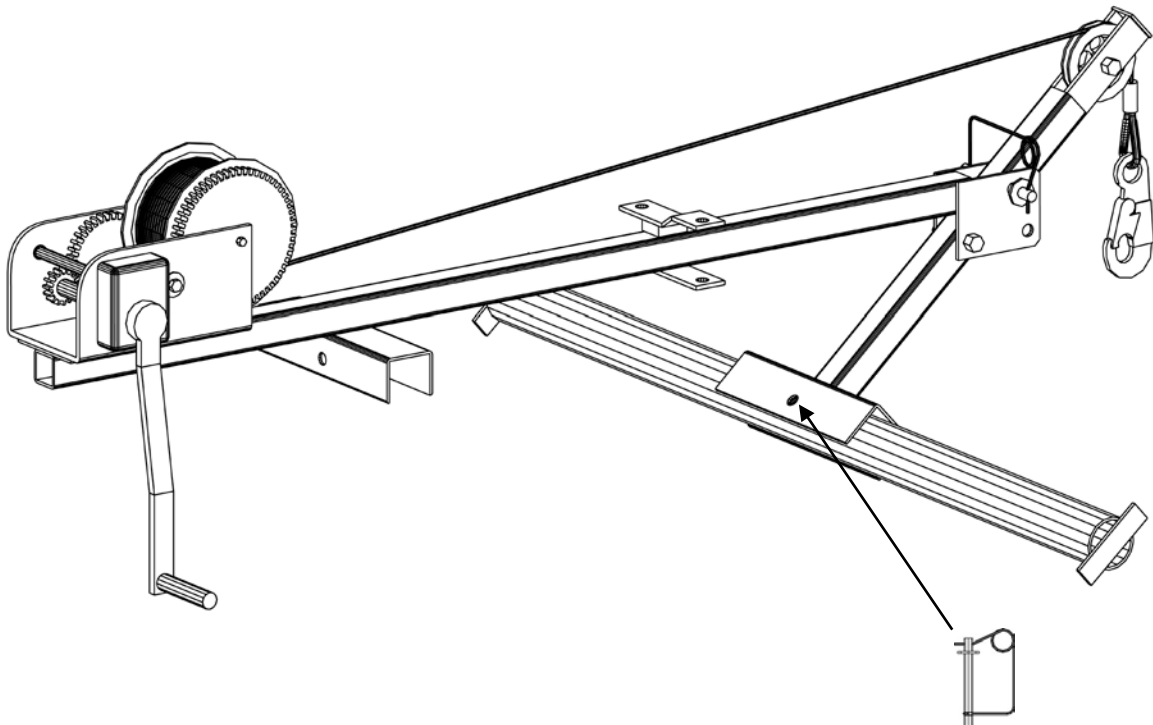

15. INSTALL THE FISHPOLE (IF APPLICABLE)

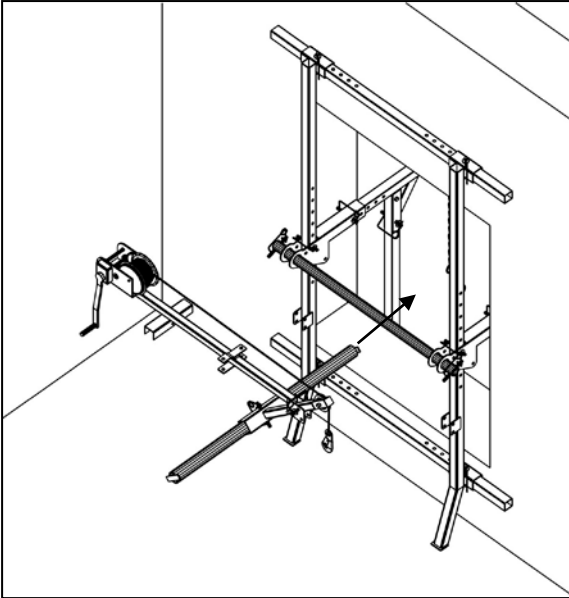

- Pass the assembled Fishpole through the window, as shown.

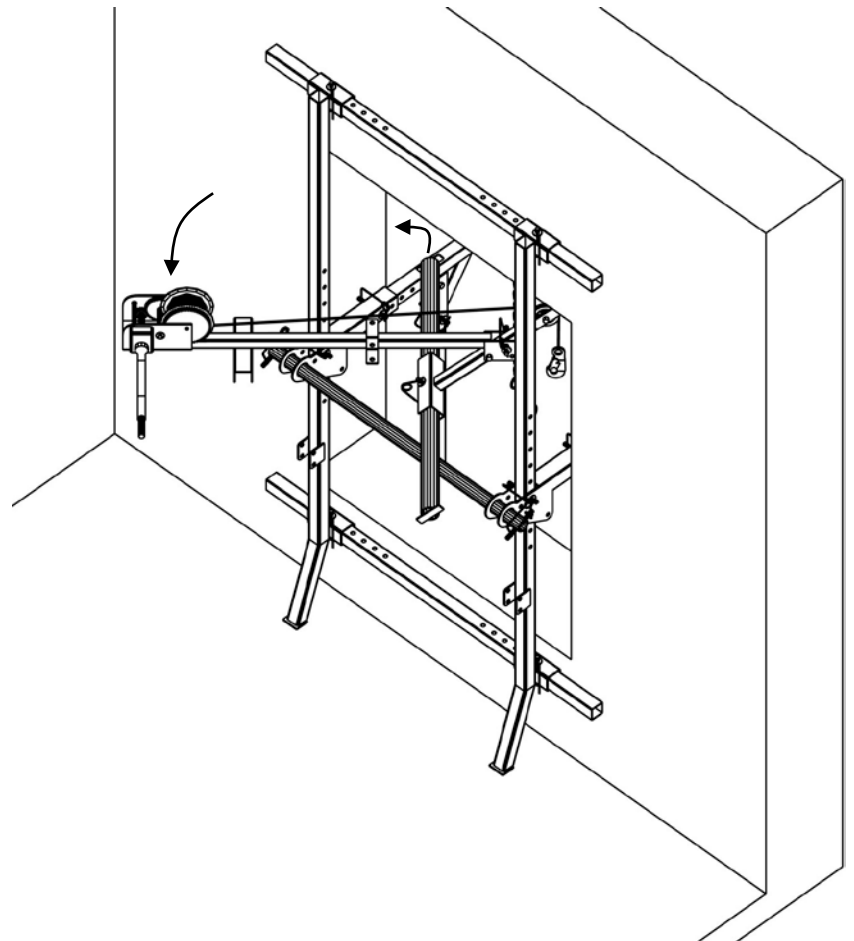

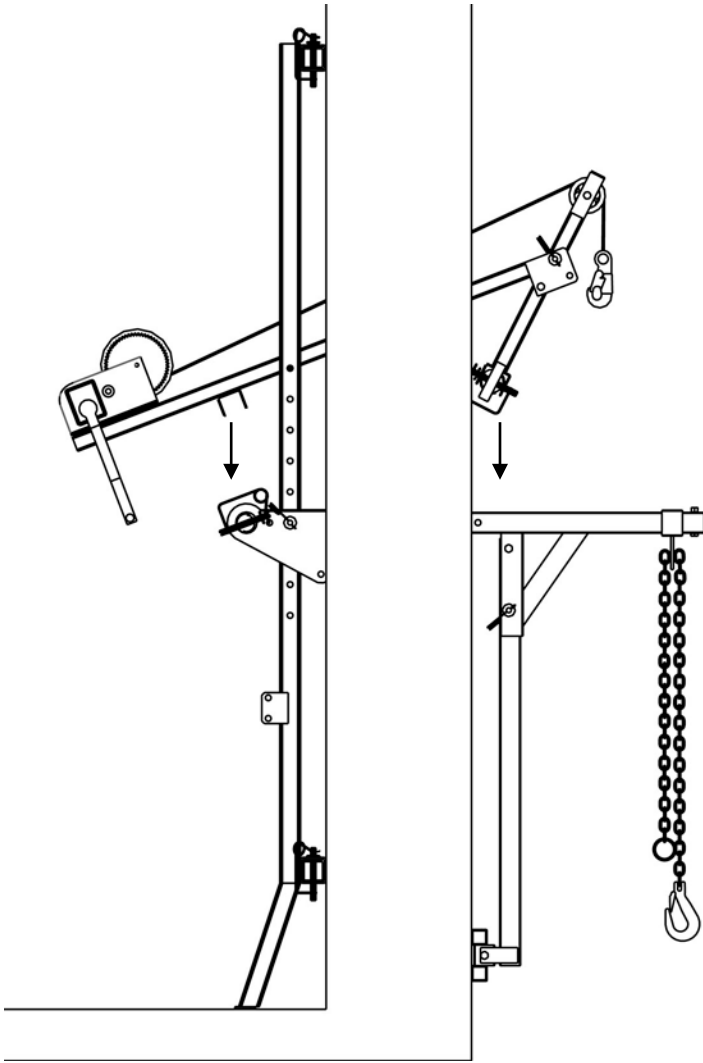

- Seat the Fishpole on the Inner Pipe, and the Booms.

- Pin the Fishpole to the Inner Pipe.

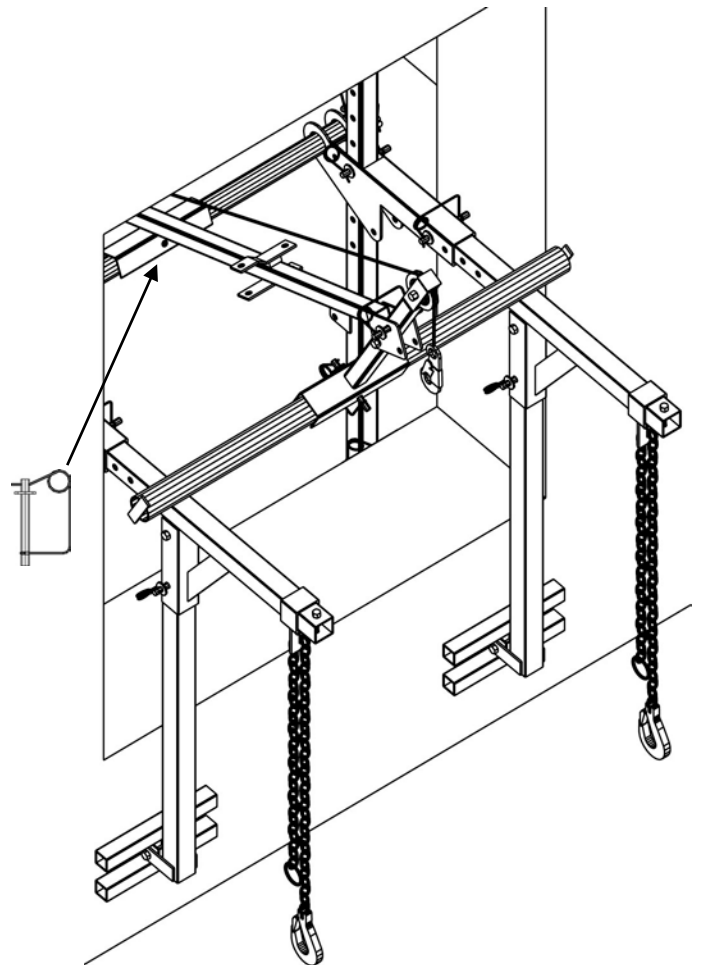

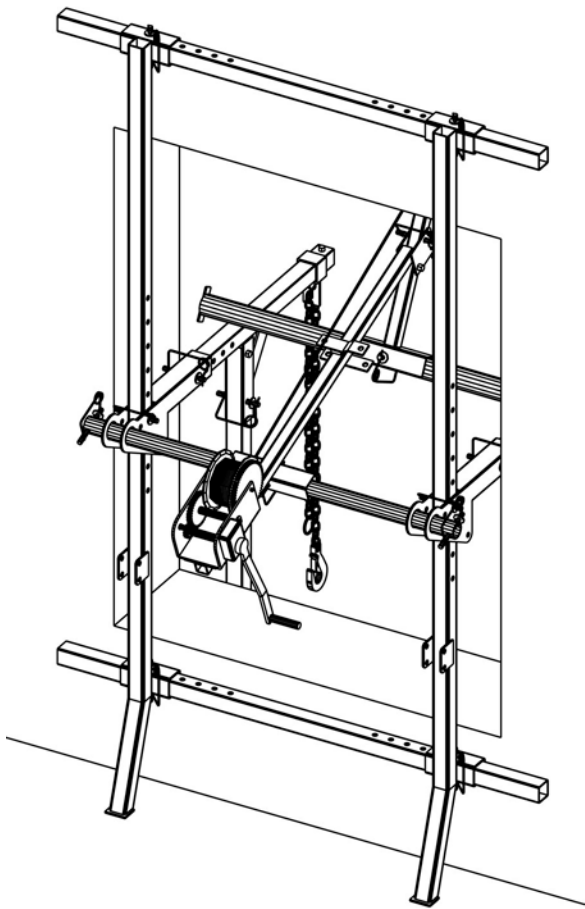

- The Fishpole is installed as shown.

- Turn the winch handle in a counter-clockwise direction to lower a few feet of cable. As the cable unspools, check it for wear and tear. If it is frayed or kinked, postpone the installation and order a new cable from Superchute Ltd.
- Use a stick, pole, broom, or some other long instrument to bring the cable onto the deck.

Warning!

Never substitute the cable (3/16" diameter, 7x19 construction) for another size or strand design.

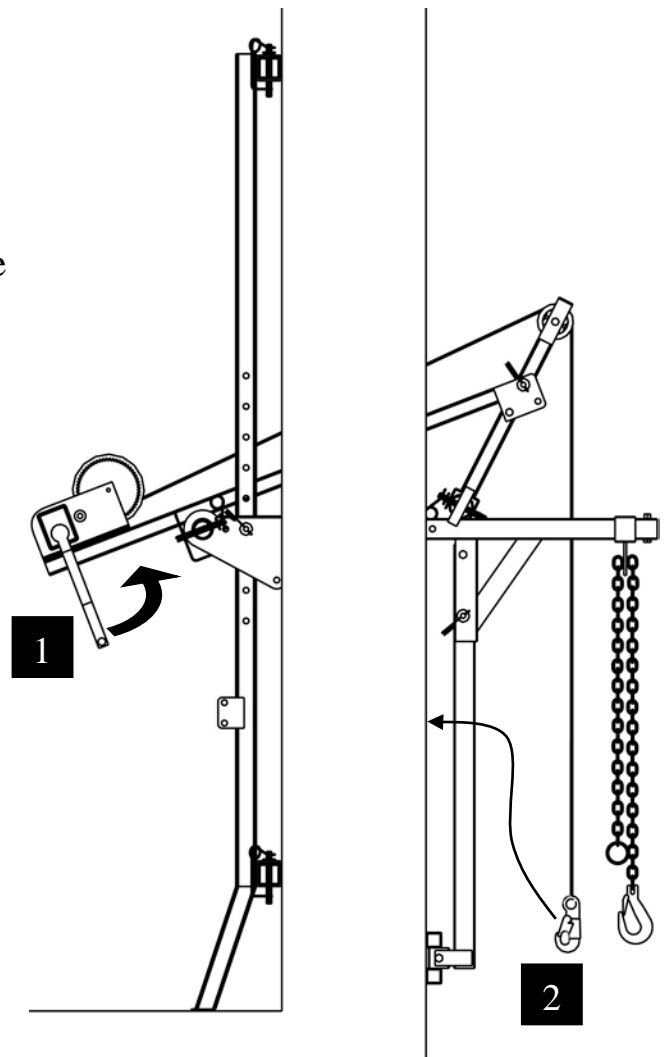

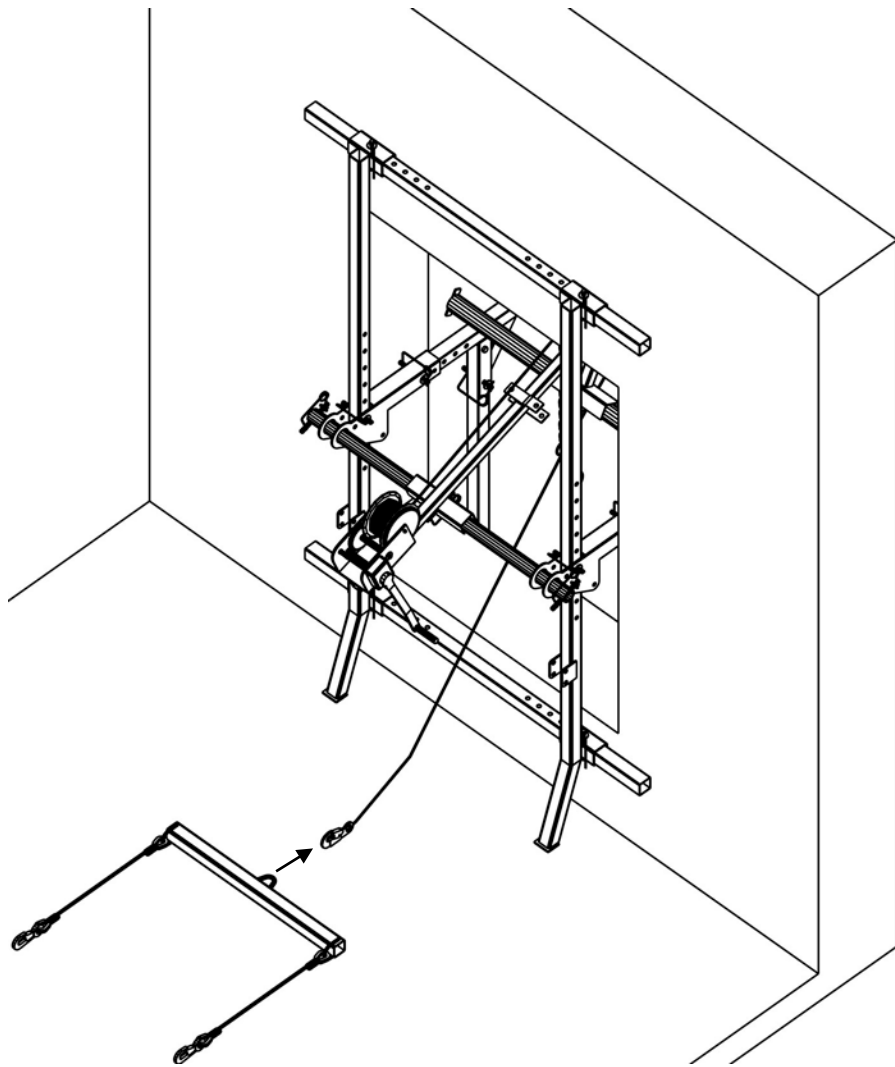

- Attach the cable's hook to the Spreader Bar.

- Lower the Spreader Bar over the building edge.

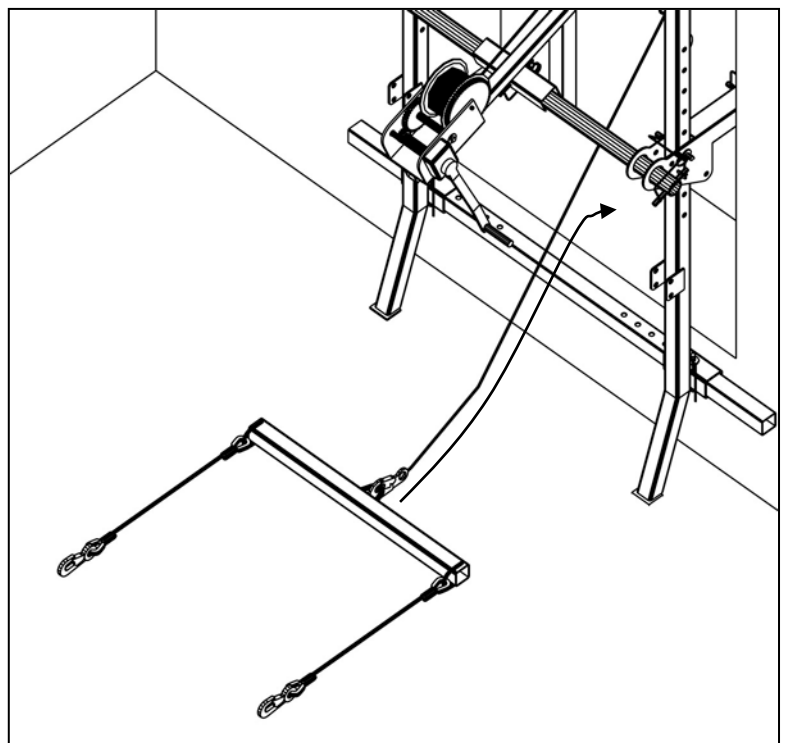

- Lower the Spreader Bar to the ground.
- Continue checking the cable for wear & tear.

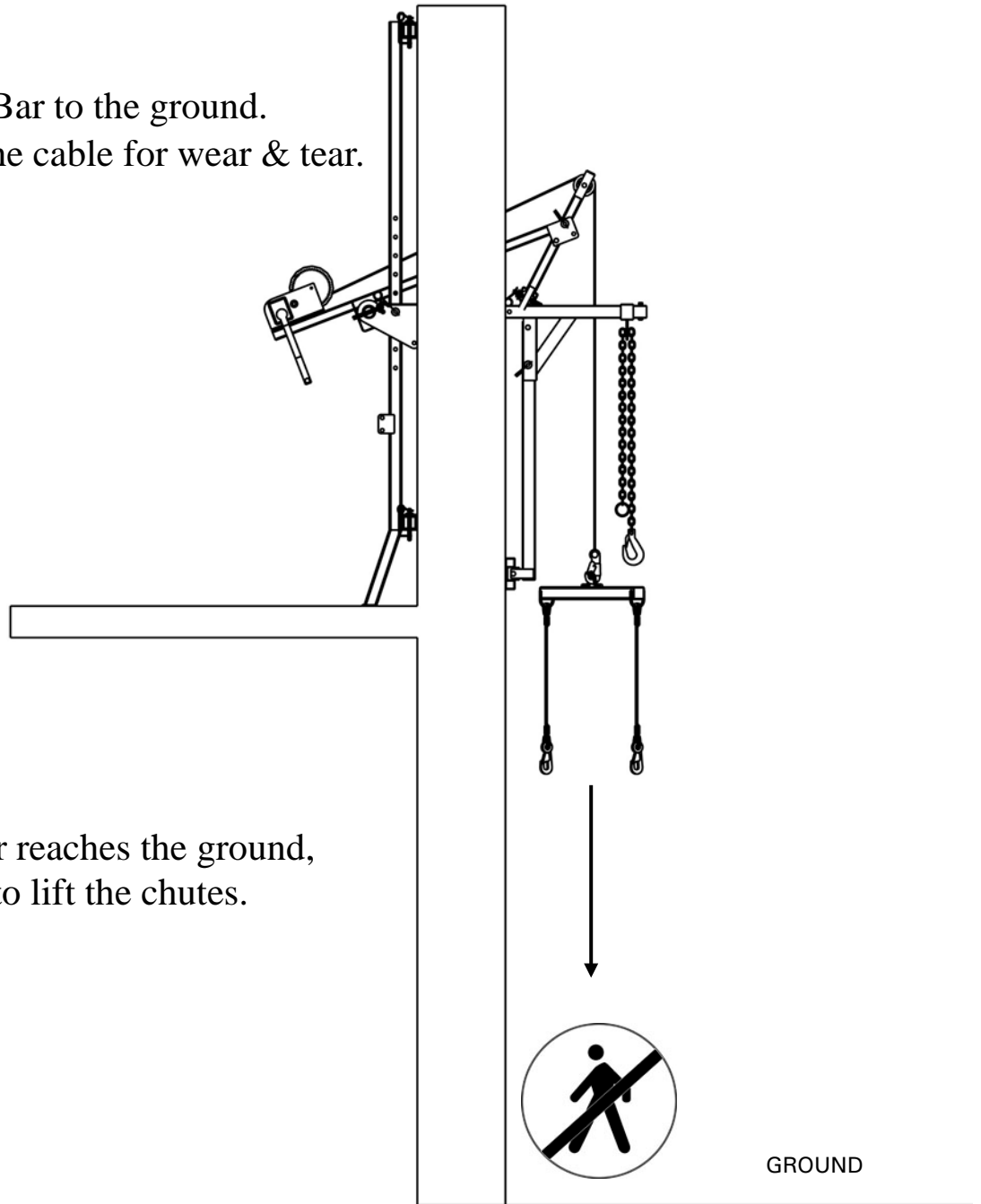

When the Spreader Bar reaches the ground, you will be ready to lift the chutes.

 **WARNING**

- The Spreader Bar can descend quickly.
- If the descending Spreader Bar were to hit a worker or bystander it could seriously injure or kill.
- Ensure the area below the hoist is clear of workers and bystanders while the Spreader Bar is descending.

16. RAISE THE CHUTE SECTIONS

Although the following sketches show the Fishpole in use, other lifting devices, such as cranes, material hoists, or boom lifts, may be appropriate as long as they can safely manage the chute load. All lifting devices require the procedure shown in this section.

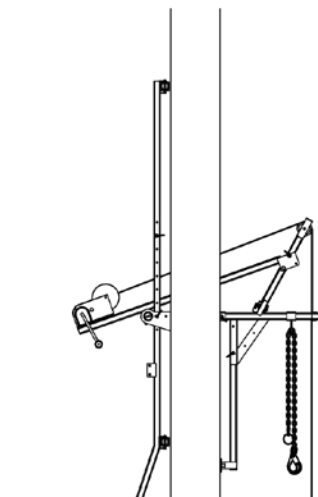
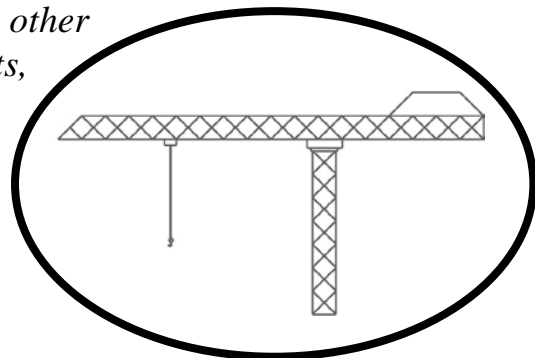

- Attach a Regular Section to the Spreader Bar.

Communication:

Ground-level workers and hoist level-workers should use 2-way radios (walkie-talkies) to communicate with each other.

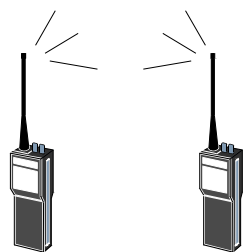

GROUND



WARNING

- GROUND WORKERS MUST WEAR HARDHATS

HOIST THE CHUTE SECTIONS INTO PLACE (continued)

- Raise the section 4 feet.

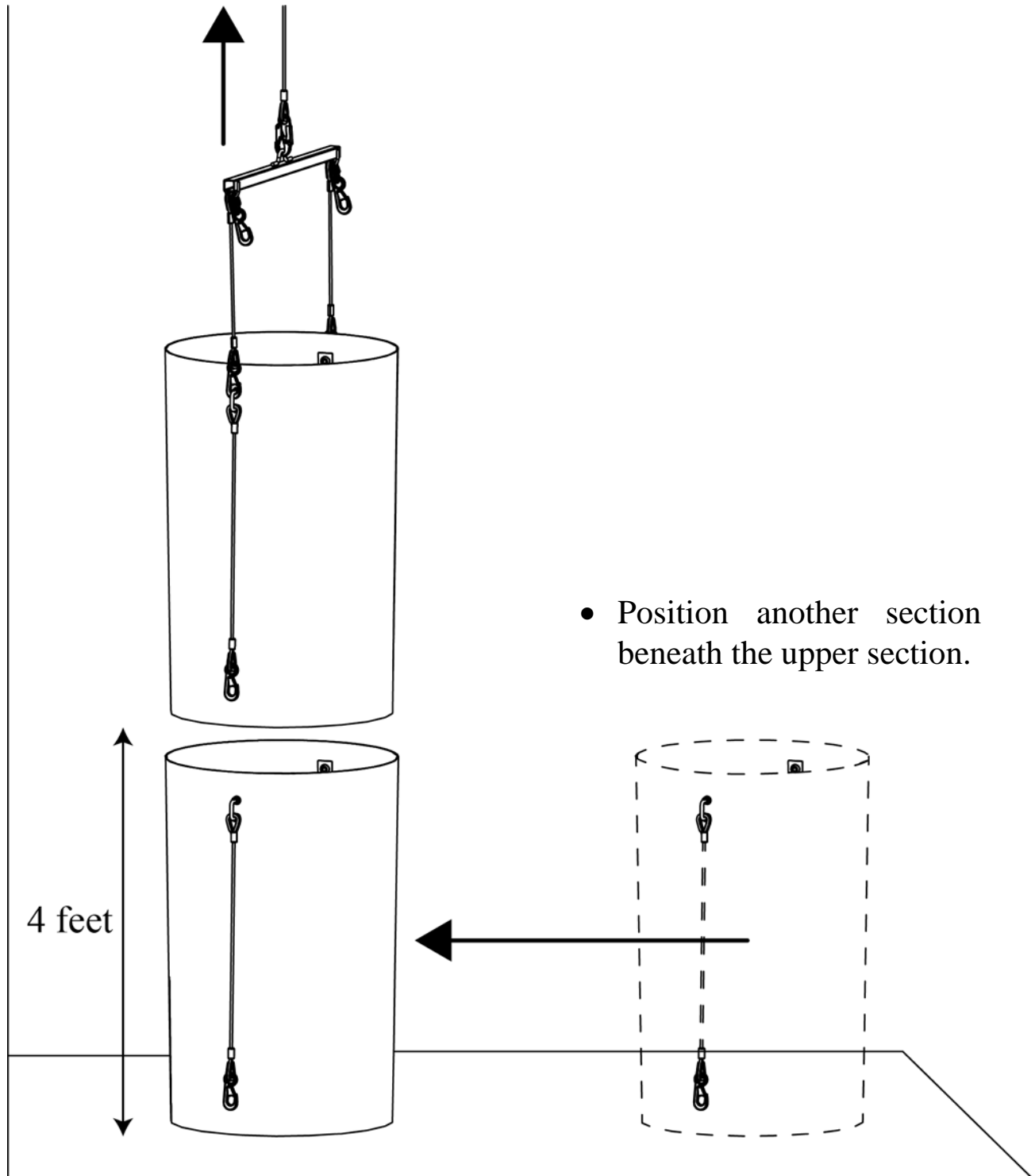

HOIST THE CHUTE SECTIONS INTO PLACE (continued)

- Lower the suspended section into the section beneath it.
- Connect the two sections with the upper section's cable assemblies.

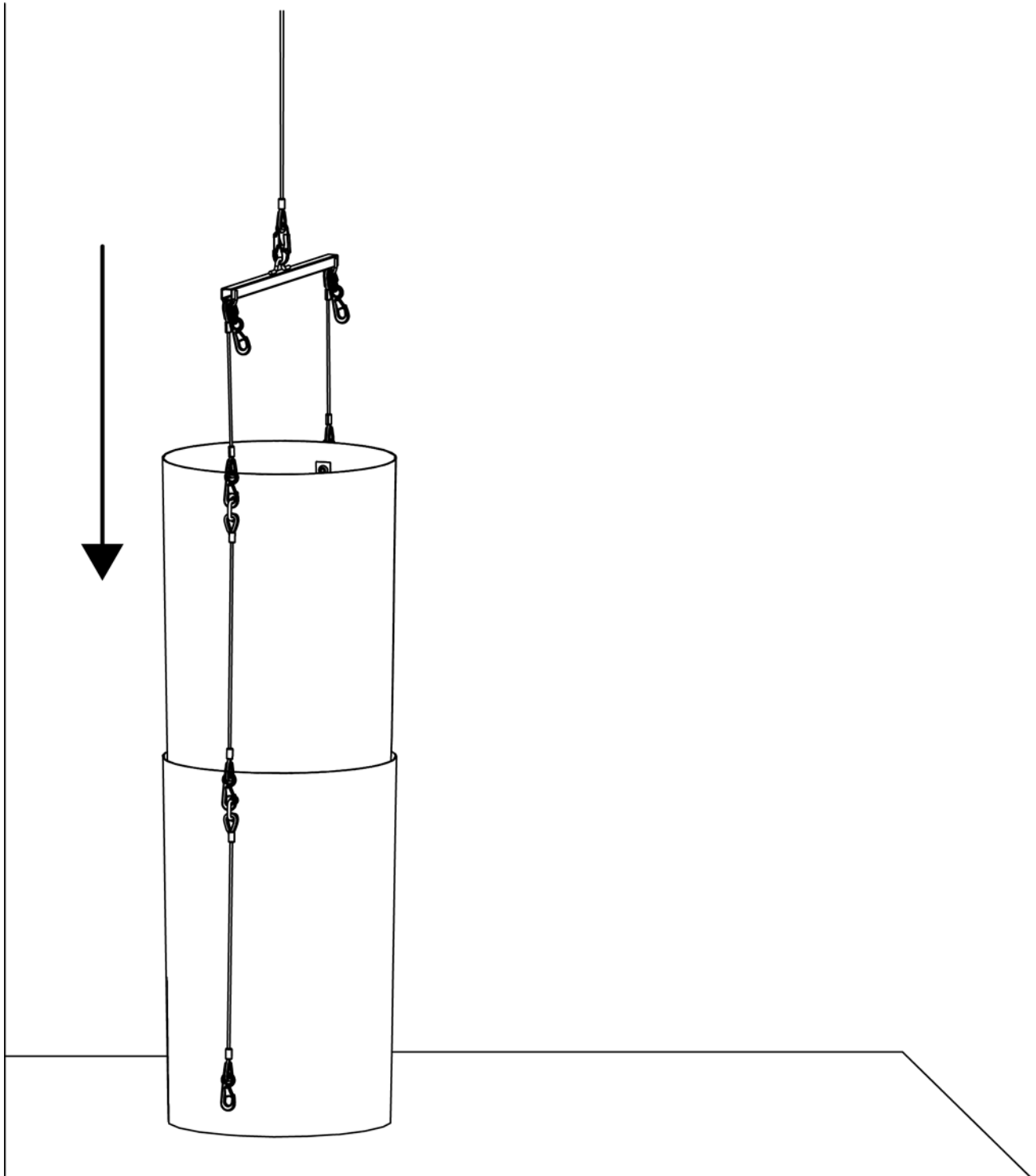

HOIST THE CHUTE SECTIONS INTO PLACE (continued)

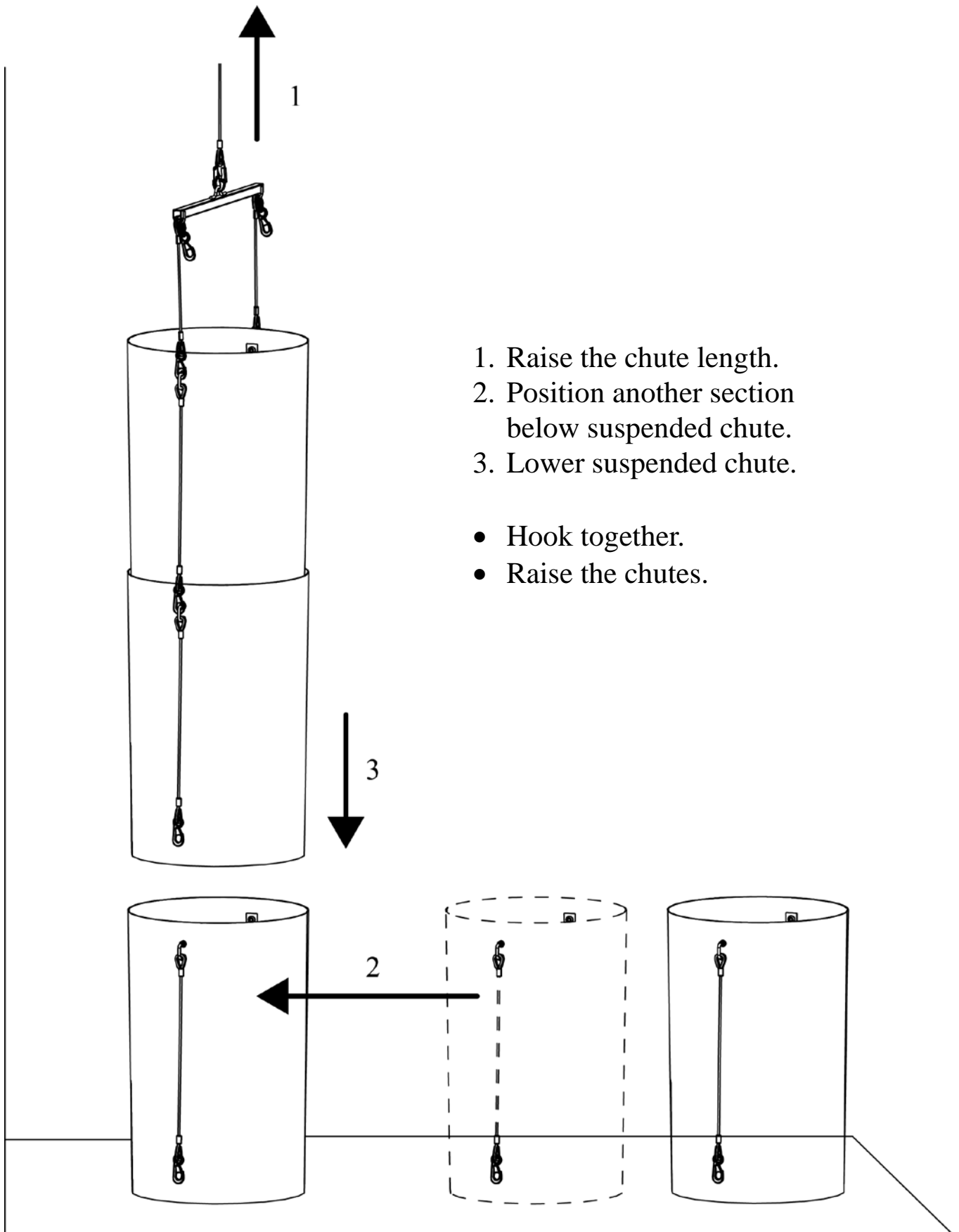

1. Raise the chute length.
2. Position another section below suspended chute.
3. Lower suspended chute.

- Hook together.
- Raise the chutes.

HOIST THE CHUTE SECTIONS INTO PLACE

- Repeat the last step until the first Regular Section arrives at the hoist level.

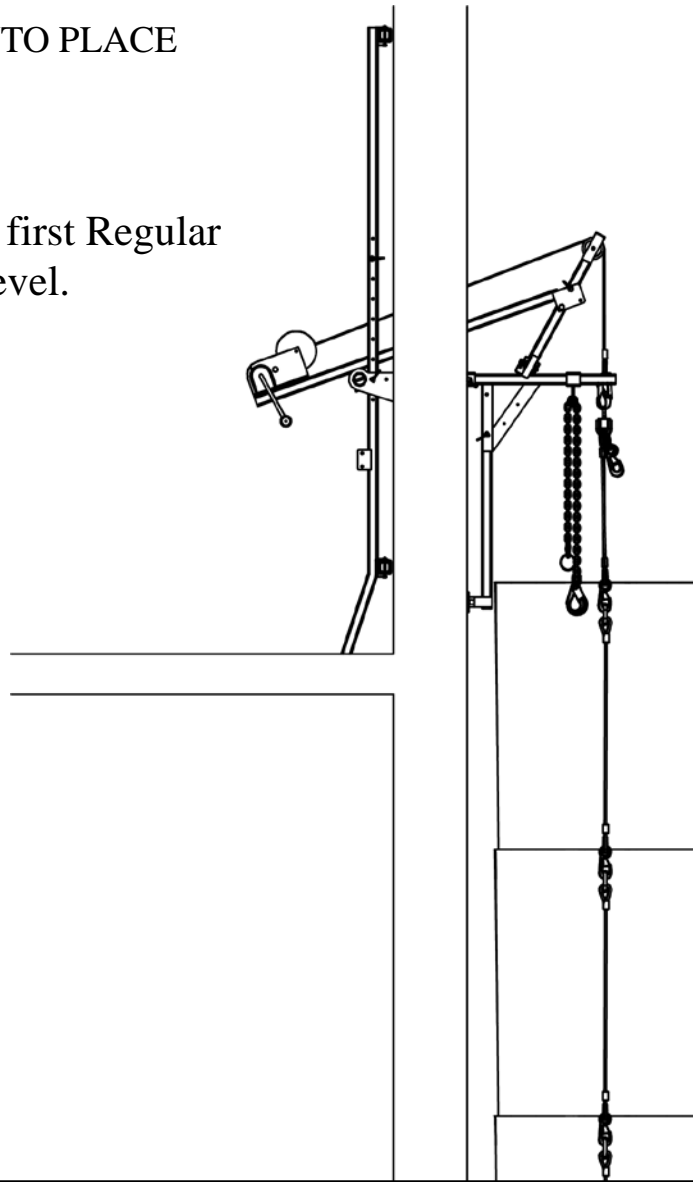

WARNING

- The SC-350-w Loadspreader has a Working Load Limit of 350 lb. (It is designed to safely lift, support, and lower a chute load weighing up to 350 lb).
- The hoist frame and/or Fishpole may fail if more than 350 lb. is applied.
- A falling chute system can seriously injure or kill.
- Do not overload the hoist frame or the Fishpole.
- Use the information in **Sections 5 & 6** to calculate the maximum number of Superchute® sections you can safely lift, suspend, & lower.

17. TRANSFER THE CHUTE LOAD FROM THE LIFTING DEVICE TO THE BOOM CHAINS

Although the following sketches show the Fishpole in use, other lifting devices, such as cranes, material hoists, or boom lifts, may be appropriate as long as they can safely manage the chute load. All lifting devices require the procedure shown in this section.

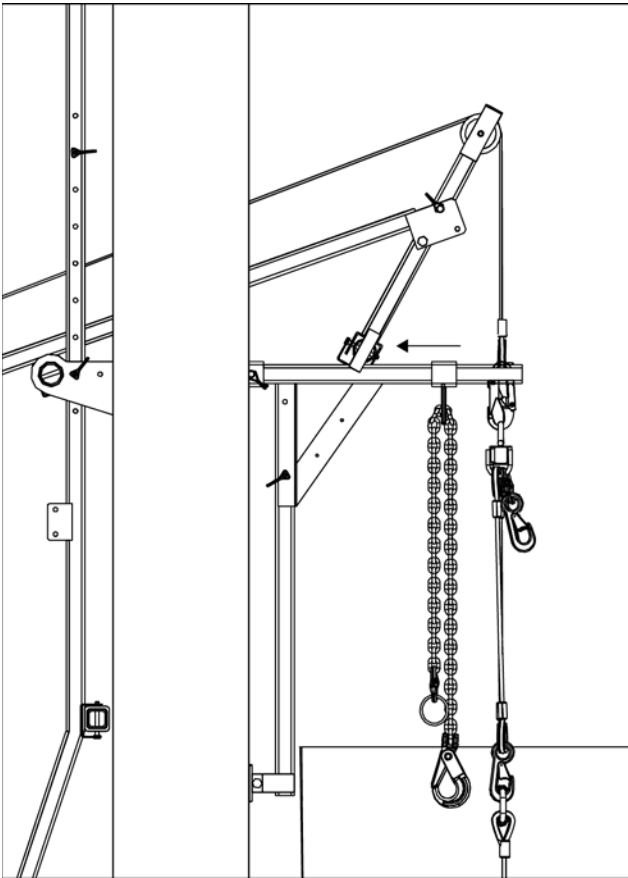

- Pull the hangers & chains towards the building.

- Adjust chains through the keyholes until the clips are level with the chute section's U-bolts.

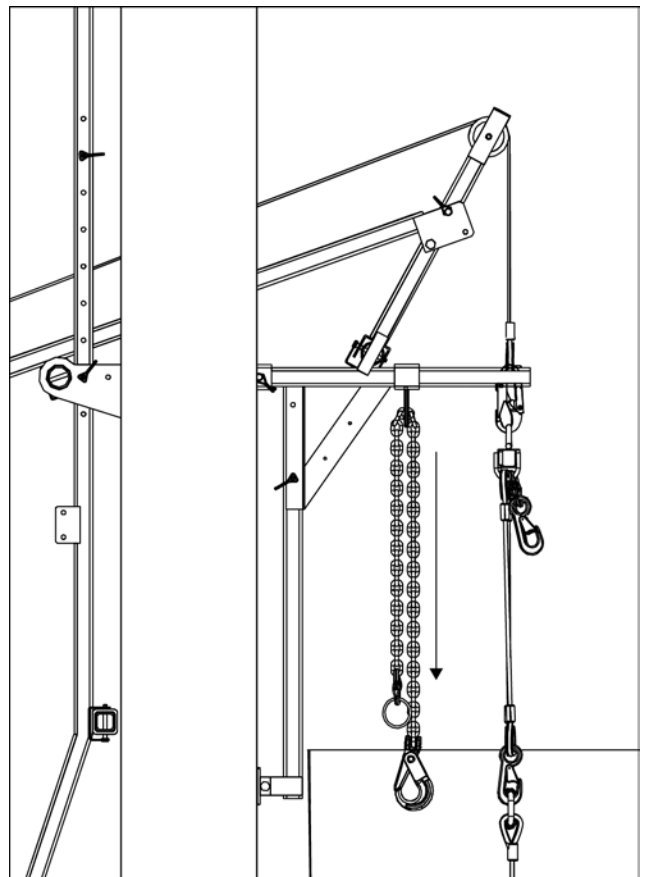

- Fine-tune the height of the uppermost Regular Section using the winch.
- Attach a Boom Chain to each U-Bolt.
- Adjust the chain lengths.
- **The chain lengths must be equal (count the links).** If the chain lengths are unequal the weight of the chute will be unevenly distributed on the hoist frame.

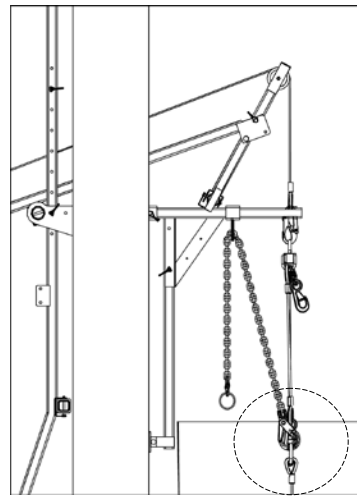

Figure A.

- Turn winch handle counter-clockwise to lower the Spreader Bar.
- The weight of the chute will transfer to the Boom Chains.
- Unhook the Spreader Bar from the chute section's U-bolts (Figure A.)
- Remove Fishpole (Figure B.)
- Insert Top Hopper into suspended chute (Figure C.)
- Secure Top Hopper to Chute (Figure D.)

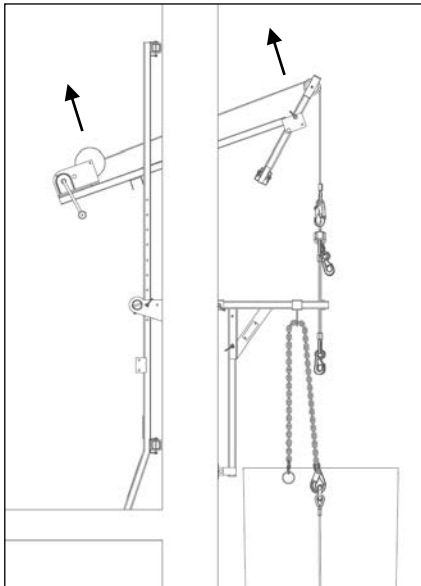

Figure B.

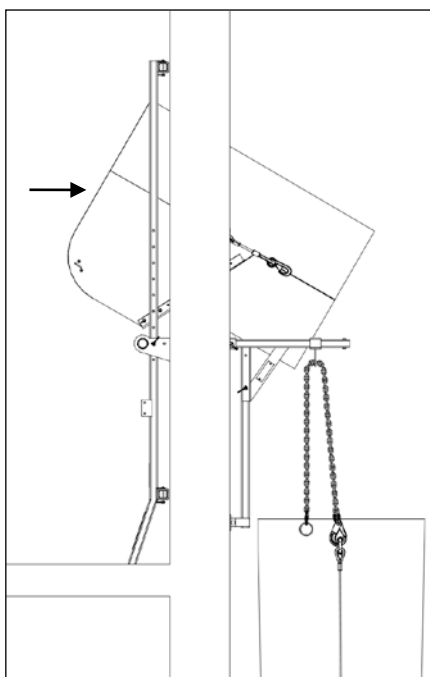

Figure C.

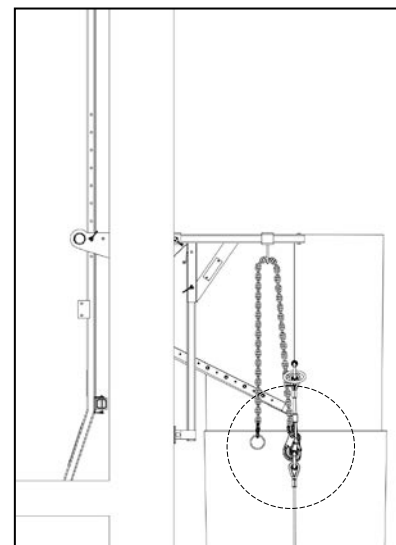
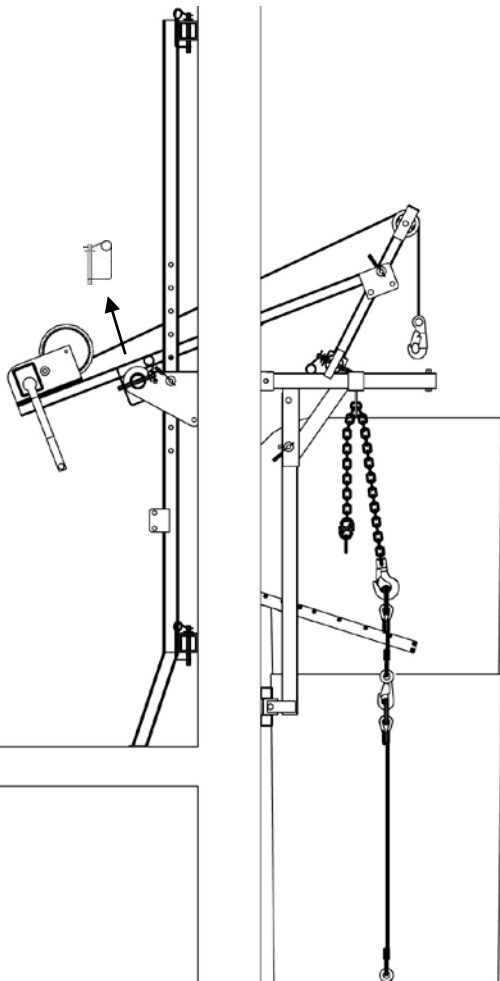
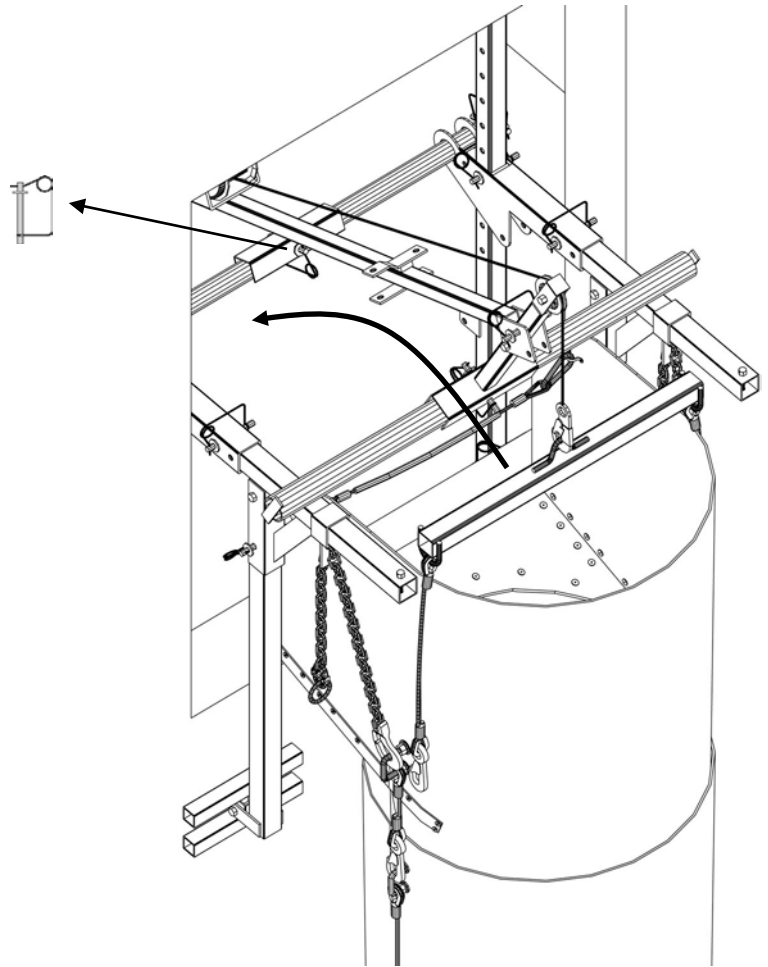

Figure D.

18. REMOVE THE FISHPOLE (IF APPLICABLE)

*If using a crane (or similar device), then please go directly to **Section 17**.*

- Remove the Spreader Bar.
- Unpin the Fishpole.



- Remove the Fishpole.

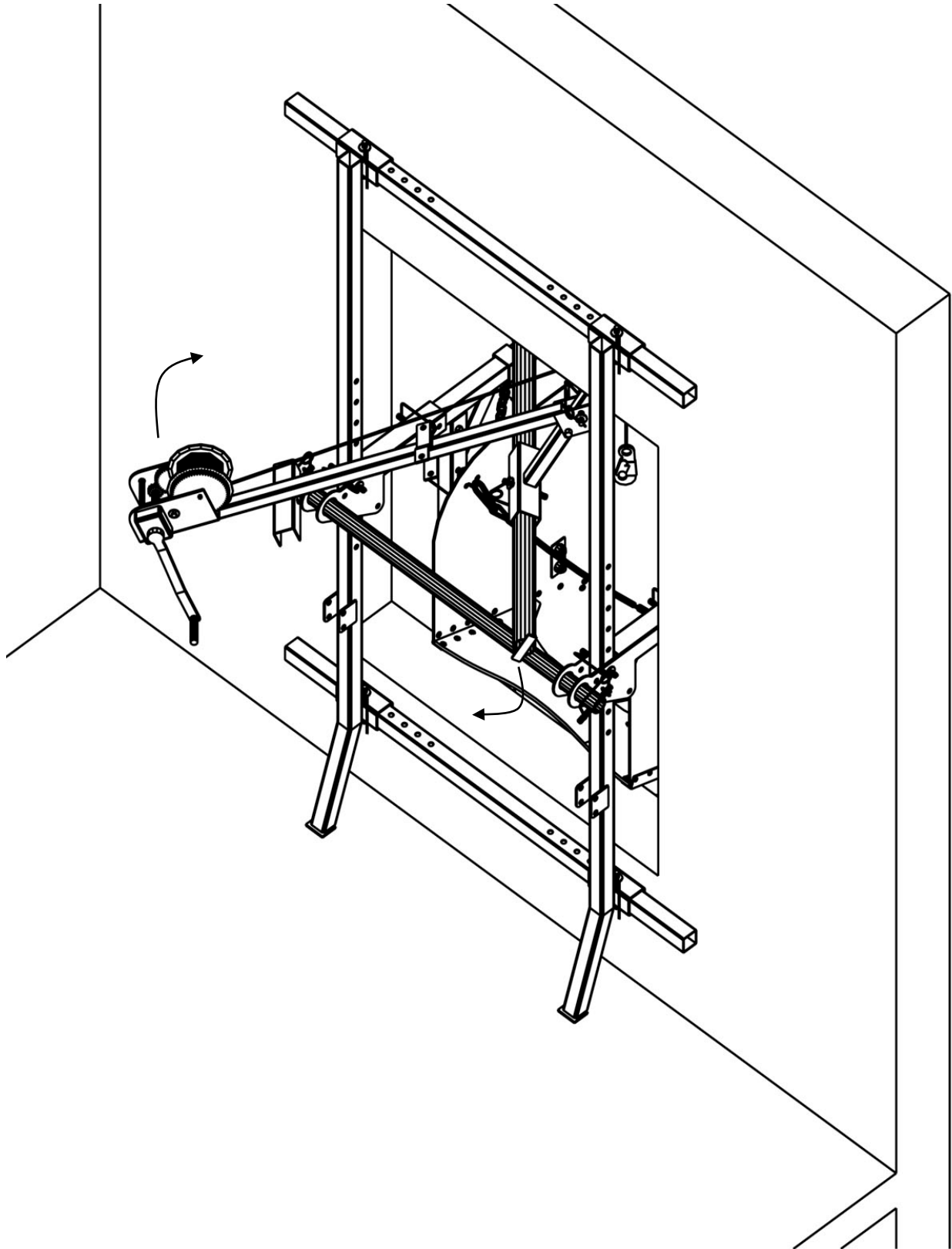

19. CONGRATULATIONS!

The installation of your SC-350-w Loadspreader Hoist is complete!

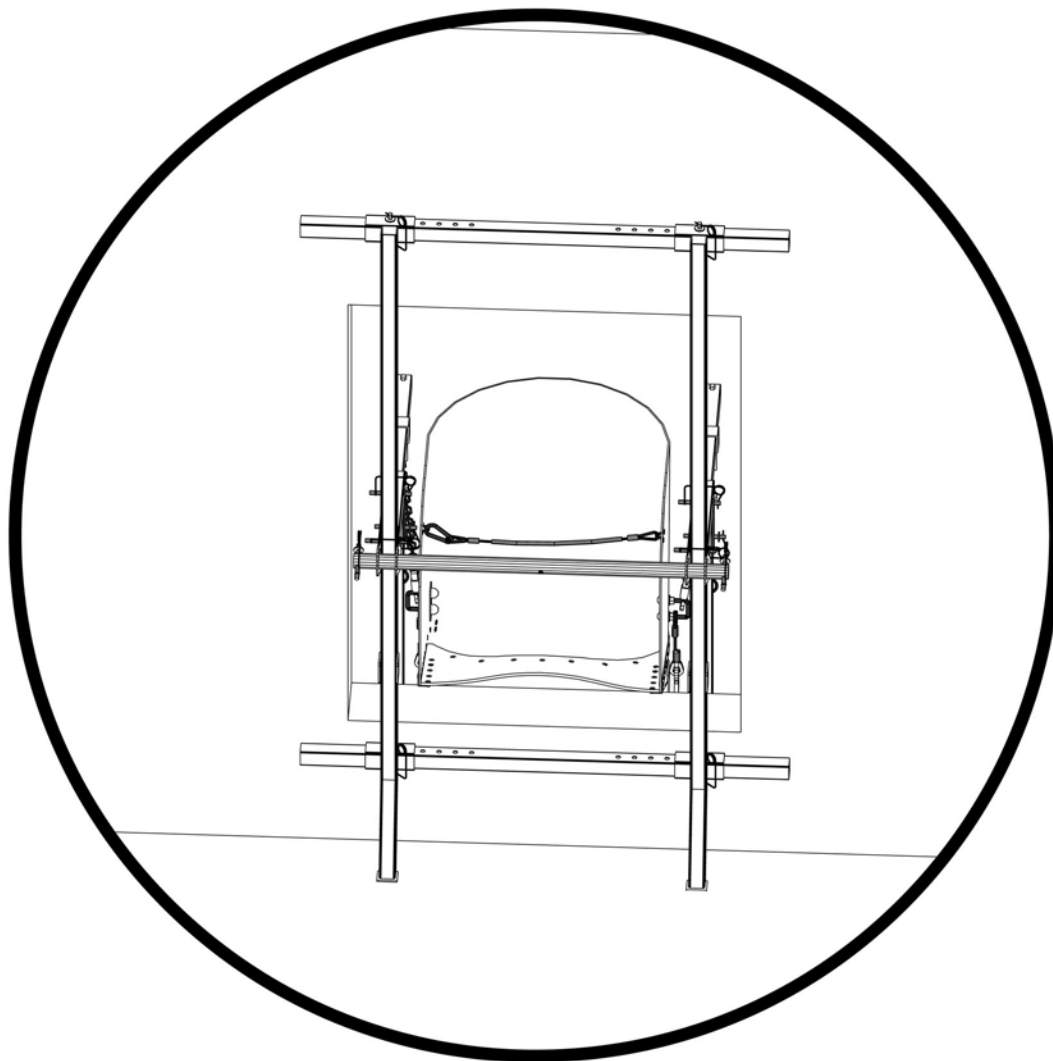

Please see the next few pages for some important information.

20. FALL PROTECTION & THE GATEKEEPER



WARNING

- If the hoisting area does not feature adequate fall prevention barriers, a person could easily fall into the chute or off the building.
- A fall from a height of 6 ft. is enough to seriously injure or kill.
- OSHA requires the use of fall prevention barriers along unprotected edges. The barriers must be at least 42" high, plus or minus 3". Guardrail systems, parapet walls, and window sills may be acceptable fall prevention barriers provided they meet OSHA's height and strength criteria.
- If the hoist's Inner Pipe is installed at a height of 42" plus or minus 3" from the floor, it is acting as a safe fall prevention barrier. The Inner Pipe may be detached if it is interfering with the debris removal process, as long as personal fall arrest systems are used, or alternate fall prevention barriers are present.
- Keep the debris removal process quick and safe in areas without adequate fall protection by designating a worker as the **Gatekeeper**.
- The Gatekeeper is secured by a personal fall arrest system to an anchor that is independent of the chute system. Because he is protected against falls, he can work near the exposed edge. At a demarcated "stop line" (where there is no risk of falling over the edge), the Gatekeeper receives full wheelbarrows from unprotected workers. He empties the wheelbarrows into the chute and returns them to the stop line in exchange for full ones.

21. DISMANTLE THE CHUTE & HOIST

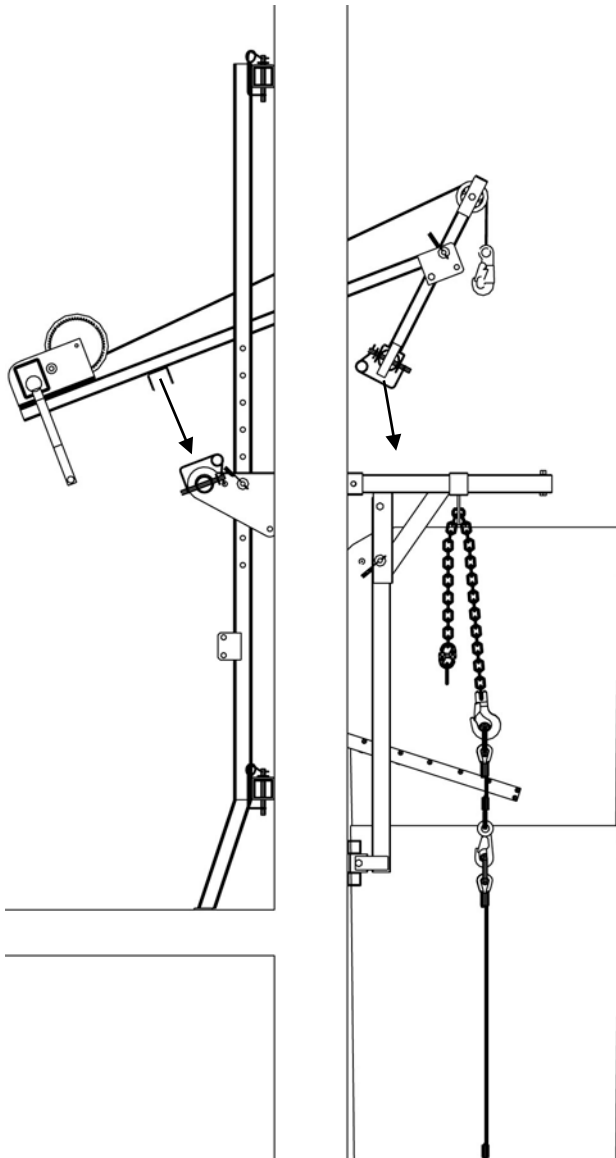

- Attach the hoisting cable to the Spreader Bar.
- Attach the Spreader Bar to the chute.
- Raise the chute a few inches to relieve the tension on the Boom Chains.
- Unhook the Boom Chains from the Top Hopper U-Bolts.

- When the debris removal operation has finished the chute and hoist will need to be dismantled using the following procedure.
- Re-attach the Fishpole (if applicable).

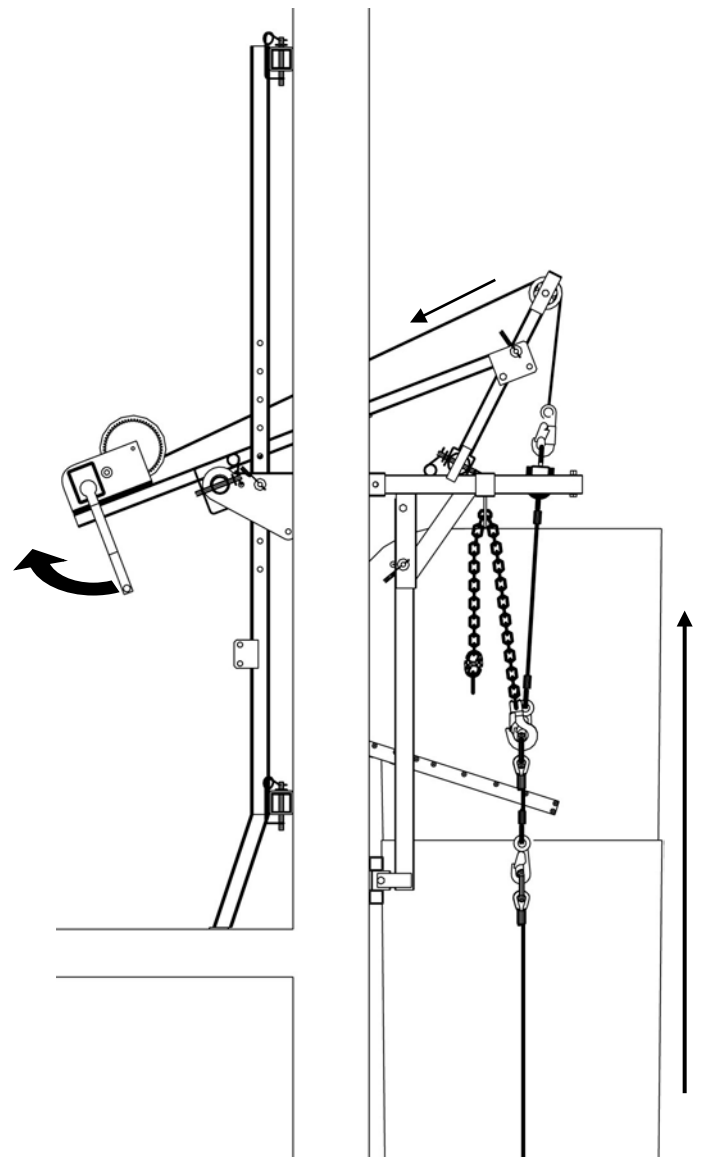

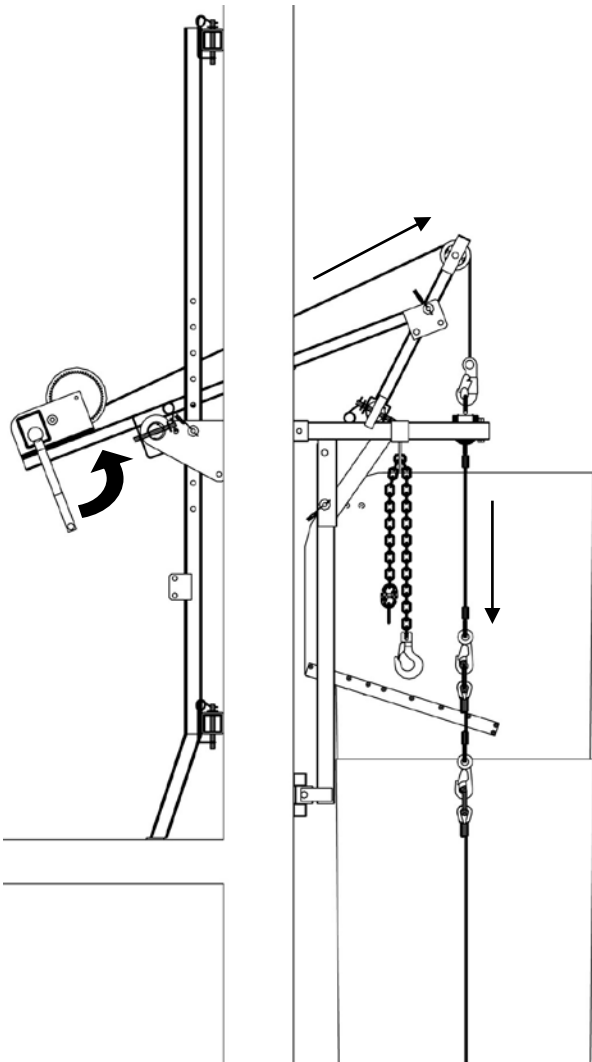

- Lower the chute length.
- As the chute descends, ground workers should remove sections.

- Remove the Fishpole (if applicable).

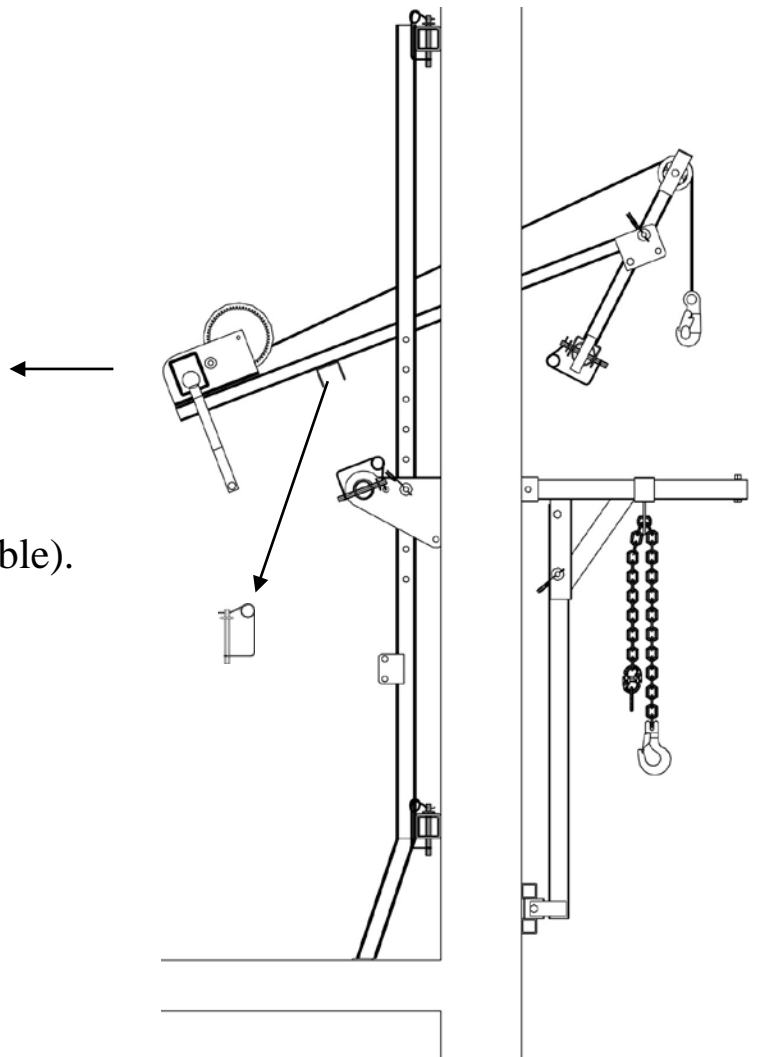



WARNING

- In the next steps, the two awkward and heavy booms will be detached and lifted through the window and into the room.
- If the worker loses his balance, he could fall through the window and be killed by the fall.
- Before detaching the booms put on a body harness with a lanyard attached to a 5000 lb. capacity anchor.

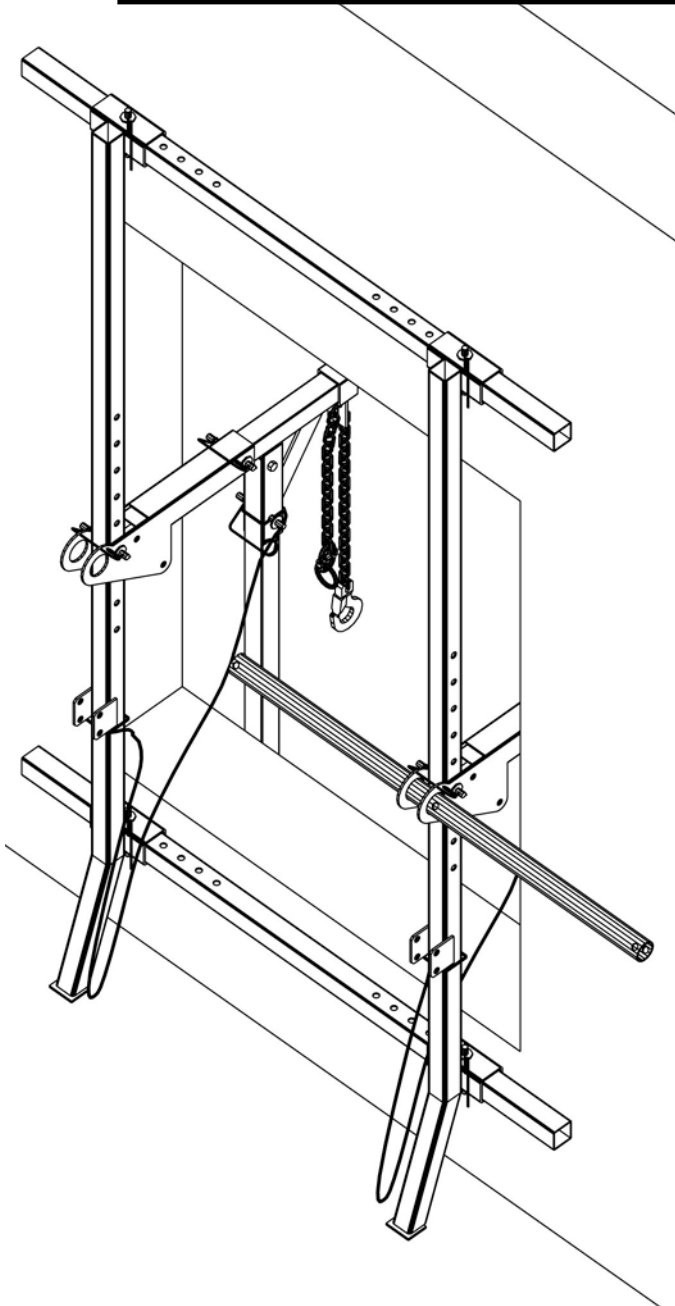

- Secure each Boom to the hoist frame using a six foot length of rope.
- If the Boom should slip out of the installer's hands, the rope will stop its fall.
- Unpin and remove the Inner Pipe.

- Unpin and remove the Booms.

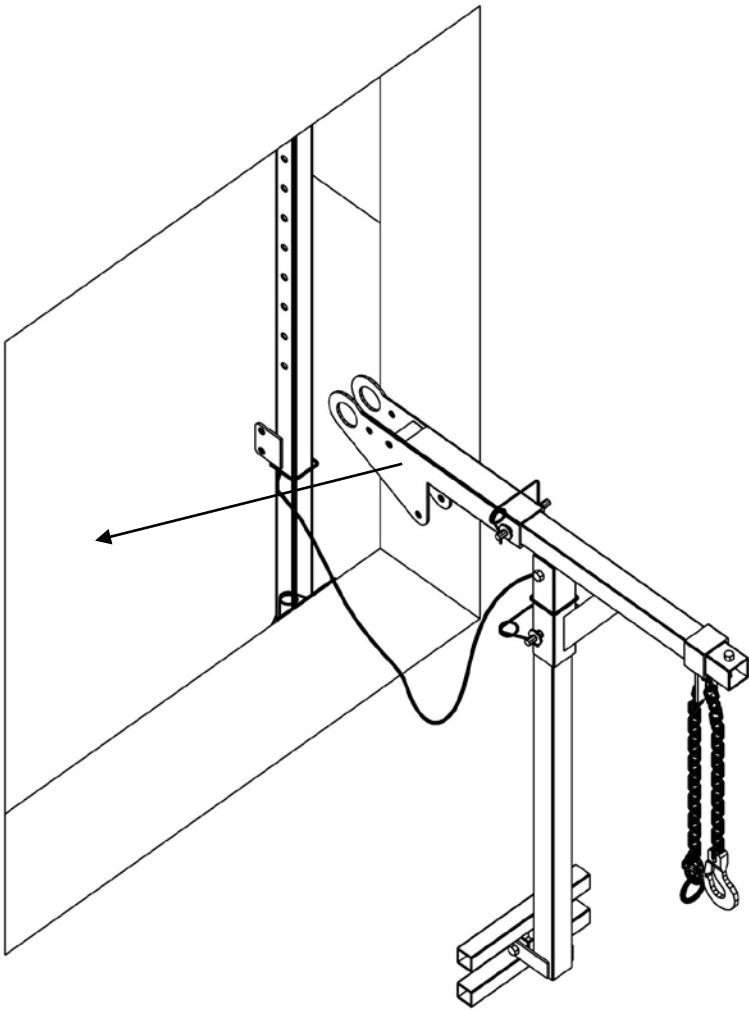

- Unpin and remove the Tie Bars.
- Store all components as packets.

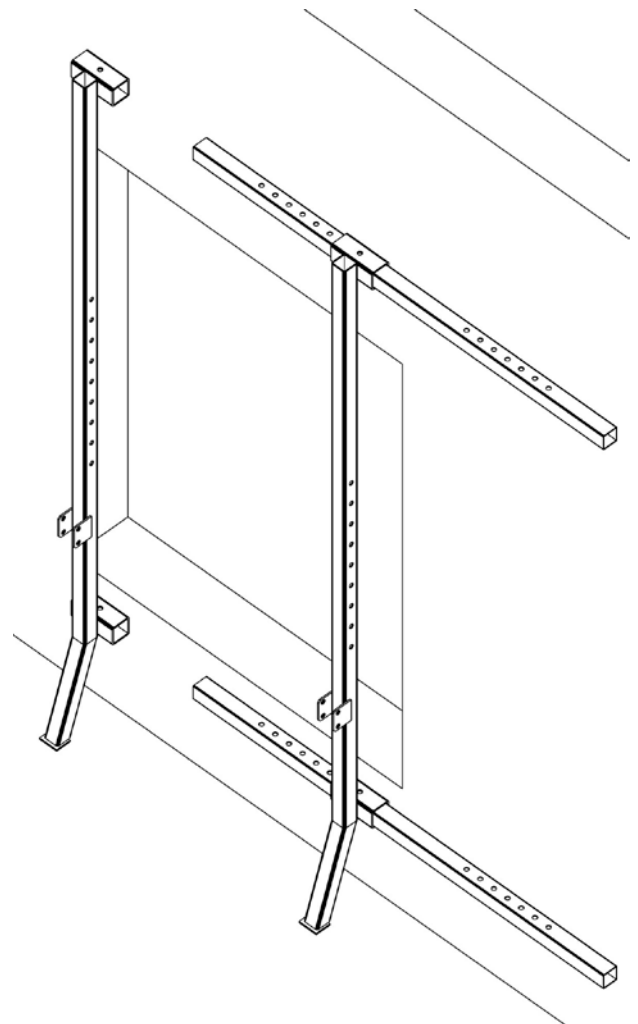

22. STORE THE HOIST AS FIVE PACKETS:

The 5 Packets:

- Mast + Tiebar (2 packets)
- Boom + Boom Tail (2 packets)
- Fishpole + Outer & Inner Pipes (1 packet)
- Spreader Bar (loose)

Spreader Bar

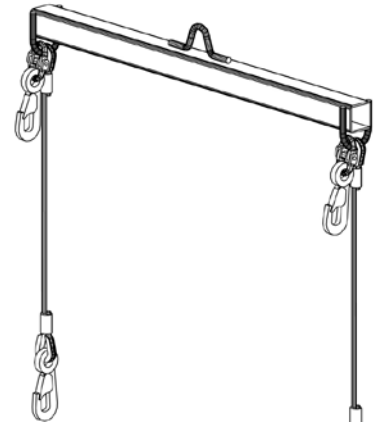

Mast + Tiebar Packets

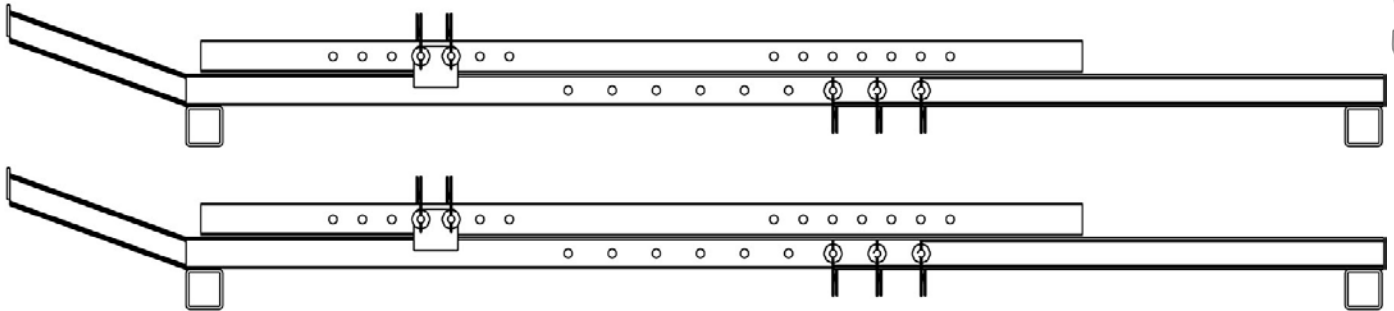

Boom + Boom Tail Packets

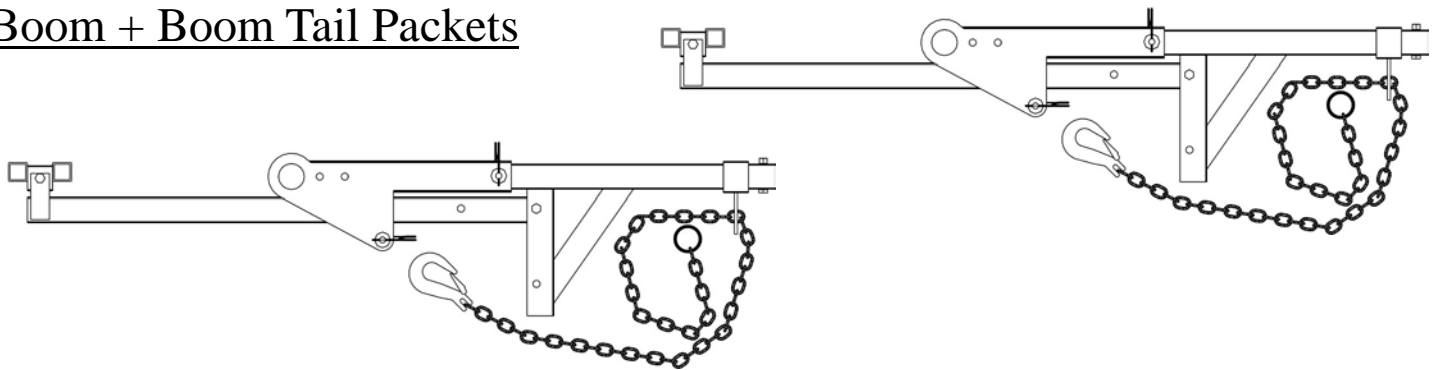

Fishpole + Outer Pipe + Inner Pipe Packet

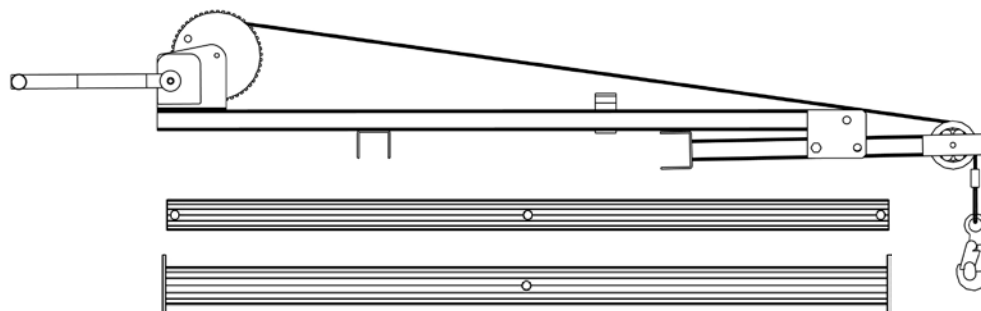

APPENDIX A: WARRANTY

Superchute® chute hoists are made for heavy wear, but like all tools, time and use will take its toll. There is no warranty for wear and tear, or misuse of the hoist. Superchute® warrants all products against manufacturing defects, which must be reported in writing to Superchute® Ltd. upon receipt of goods. Thorough overhaul servicing is offered by Superchute® Ltd.

APPENDIX B: STAY INFORMED

The Superchute® factory sends out regular notices regarding new products, changes, recalls, and upgrades. Stay informed by filling out the form below and sending it in. Please feel free to enclose any other comments. Thank you for choosing Superchute® Ltd.

Your Name: _____	E-mail address: _____
Company: _____	
Address: _____	Website: _____
Phone: _____	
Fax: _____	
Number of chute sections owned: _____	
Diameter(s) of the chute sections: _____	
Date(s) of purchase: _____	
Name of the Supplier: _____	
Number of chute hoist(s) owned: _____	
Models and Serial Numbers: _____	
Date(s) of purchase: _____	
Name of the Supplier: _____	

Fax to: 514-365-8987, or mail to: Superchute® Ltd., 8810 Elmslie Road, Montreal, QC, Canada, H8R 1V6

APPENDIX C: PARTS LIST & FACTORY CERTIFICATE

LOADSPREADER MODEL SC-350-w

1. Frame Components

Quantity

Factory

Office
Initials:

	Quantity	Factory	Office Initials:
Masts	2		
Tiebars	2		
Booms with chains	2		
Boom Tails	2		
Inner Pipe	1		
5/16" diameter locking pins	12		
5/16" diameter locking pins: SPARE	2		

2. Hoisting Components

Fishpole + sheave + Shelby winch + cable	1		
Outer Pipe	1		
5/16" diameter locking pins	3		
Light Duty Lifting Bar (WLL 1000 lb.)	1		

I _____ certify that the frame was fully assembled & checked prior to leaving the factory.

use capitals

signed: production crew member

date

Serial Number(s):

TESTER: PHOTOCOPY THIS FORM AND ATTACH TO CLIENT'S FILE

APPENDIX D: GLOSSARY

Breaking Strain: The average load at which a new component (for example: a cable or chain assembly) will fail. The breaking strain is obtained by applying direct tension to a component at a uniform rate of speed, in a testing machine.

Chute: A series of linked chute sections that are used to convey debris.

Chute Hoist: An engineered device that has been designed specifically to raise, anchor, and lower a chute. A chute hoist consists of a support frame and a detachable winch apparatus (known as the Fishpole). The support frame, without the Fishpole, can still be referred to as a chute hoist.

Chute Sections: Modular conical tubes that can be linked together in series to form a chute.

Chute System: A suspended chute and the anchors (including chute hoists) that support it.

Design Factor: Also known as the “safety factor”, it is a product’s theoretical reserve capacity. The design factor is calculated by dividing the Breaking Strain by the Working Load Limit. The design factor is generally expressed as a ratio, for example: 10 to 1, or 10:1.

Users: The term “users” includes planners, supervisors, installers, and end-users of the chute hoist.

Working Load Limit:

The maximum load which can be applied to the component, when the component is new, or in “good as new” condition, and when the load is applied in the intended manner. This term can be abbreviated to WLL.

The Working Load Limit of the SC-350-w Loadspreader Hoist is 350 lb.

APPENDIX E: WINCH INFORMATION (IF APPLICABLE)

If a Fishpole is part of your SC-350-w Loadspreader hoist, then the following information applies:

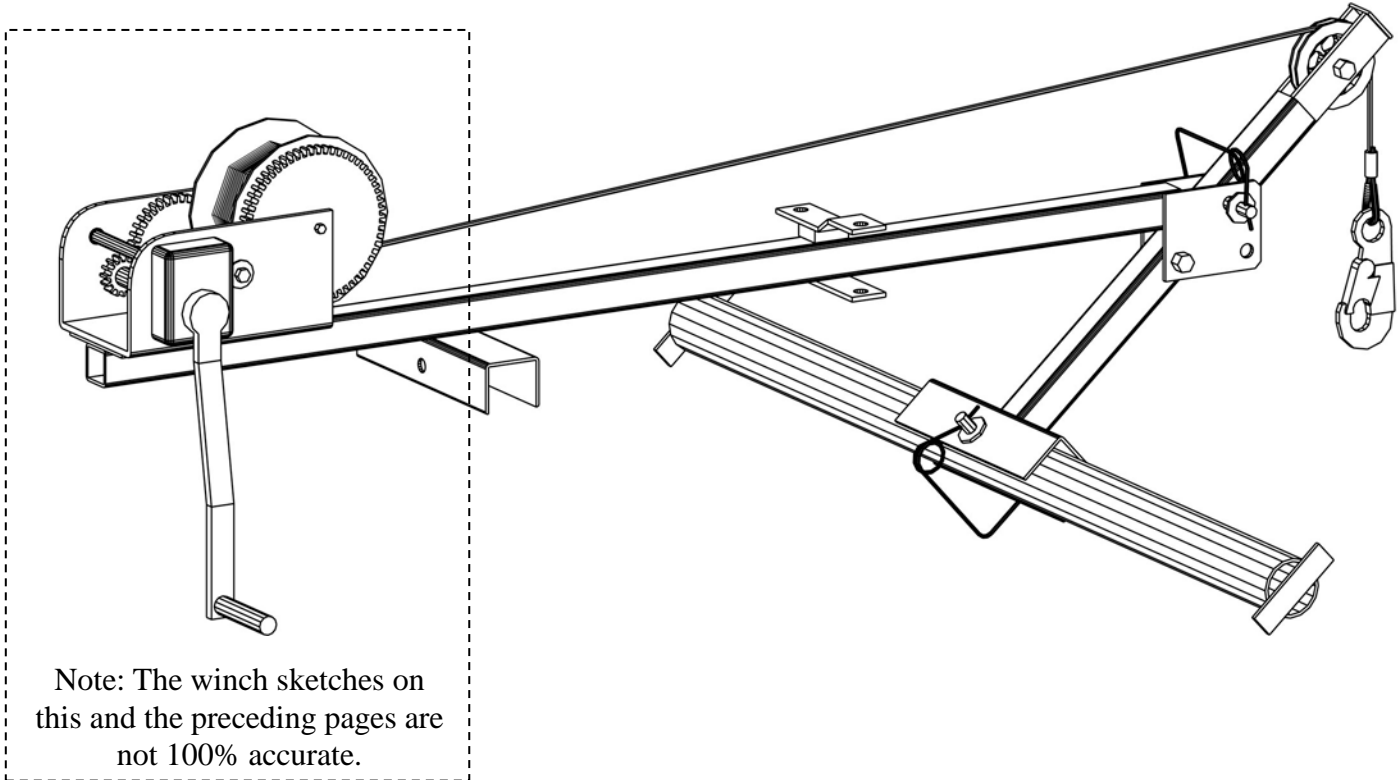

The Fishpole is equipped with a drum-style winch.

Winch manufacturer: Shelby Industries
Telephone: (502) 633-2040
Winch model: 5352
Further information: The next 4 pages are provided by the manufacturer of the winch.

SHELBY INDUSTRIES WINCH MANUAL

OWNER'S MANUAL & PARTS LIST WINCH MODEL 5352

1500 Lb. (680 kg) Maximum Rated Line Pull

WARNING

THIS EQUIPMENT SHOULD NOT BE INSTALLED, OPERATED OR MAINTAINED BY ANY INDIVIDUAL WHO HAS NOT READ ALL THE CONTENTS OF THIS OWNER'S OPERATING MANUAL.

FAILURE TO READ AND APPLY THE INSTRUCTIONS AND WARNINGS CONTAINED HEREIN CAN RESULT IN SUDDEN FAILURE OF EQUIPMENT, PROPERTY DAMAGE AND SERIOUS INJURY.

I. ASSEMBLY INSTRUCTIONS

- A. **HANDLE.** Insert handle (item 6, Fig. 1) on threaded brake assembly shaft. Thread handle to point of engagement (touching) of brake pad.
- B. **HANDLE RETAINER ASSEMBLY.** Insert Bolt (Item 1, Fig. 1) through lockwasher (Item 2, Fig. 1), flatwasher (Item 3, Fig. 1), spacer (Item 4, Fig. 1) and spring (Item 5, Fig. 1- spring will fit over spacer). Recheck Fig. 1 to ensure proper order of assembly.

Install bolt containing assembled retainer parts (Fig. 1) into threaded end of brake shaft and tighten bolt securely.

II. MOUNTING INSTRUCTIONS

- A. This winch is designed to be attached to a mounting plate or structure capable of supporting the load that it is intended to pull (lift).
- B. The winch should be mounted, using three 3/8" dia. S.A.E. Grade 5 bolts (not supplied). Two bolts should attach the winch to the mounting structure utilizing the outside rear holes or slots. The third bolt should be inserted through the winch frame and mounting structure in a manner to utilize the foremost remaining frame slot (hole) (Fig. 2).

III. CABLE ASSEMBLY INSTRUCTIONS

- A. **CABLE ATTACHMENT.** Winch model 5352 is designed for up to 95 ft. of 1/4" dia., 7 x 19 galvanized aircraft-quality cable.
 1. Feed cable into bottom of drum (item 7, Fig.3). From inside drum, thread the cable through one round hole in the drum side, until it extends 1-1/2" past the two square holes.
 2. Clamp the cable to the outside of the drum with keeper parts (items 8, 9, 10, Fig. 3). Be sure that carriage bolt heads are on the inside of winch drum.

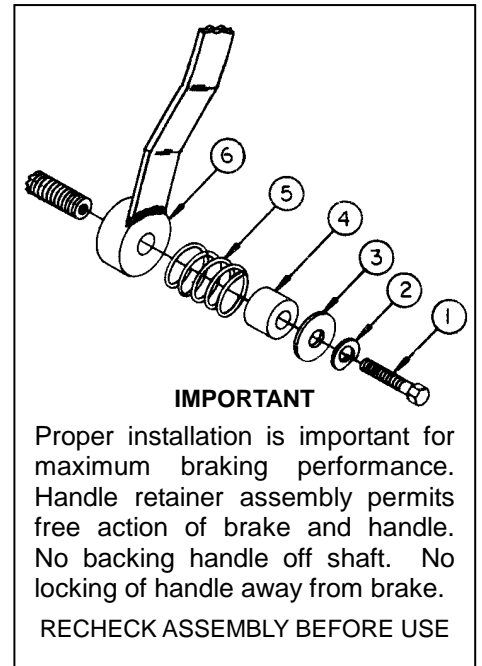

Fig. 1: Handle Retainer Assembly

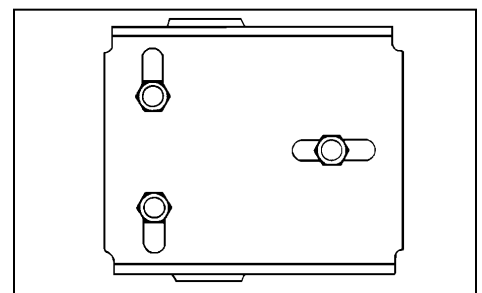

Fig. 2: Mounting instruction

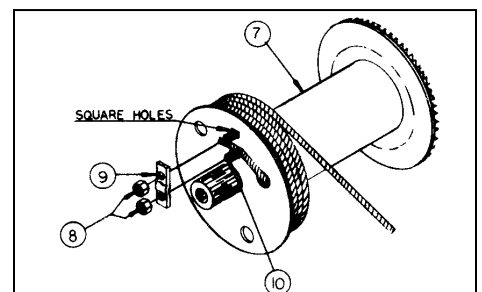

Fig. 3: Cable installation



CAUTION

1. Always be sure cable is strong enough to support the load to lifted.
2. Always inspect cable and attachment hook before each use to ensure they are not damaged.
3. Replace cable if worn, frayed or kinked. If the cable or hook breaks, the cable can act like a whip and inflict serious injury to anyone in the path of its movement.
4. Never stand alongside winch cable, or guide the cable with your hands.
5. Never fully extend cable and ALWAYS keep three (3) complete wraps of cable around drum.
6. Always be sure cable is pulling straight off winch – not at an angle. This will prevent cable from rubbing against winch drum, avoiding cable damage.

IV. OPERATING PROCEDURE

- A. **TO REEL IN OR LIFT LOAD.** This winch is designed to lift a load (reel in) by turning the hand crank in a clockwise direction. This action will produce a clicking sound inside the winch mechanism. To LOCK the load at any desired position, release handle slowly.
- B. **TO REEL OUT OR LOWER LOAD.** To lower load (reel out), turn handle crank in a counter-clockwise direction. To LOCK load in any desired position, turn handle clockwise until at least (2) clicks (approximately 8” movement of handle) are heard inside the winch mechanism before releasing handle.

CAUTION: If hand slips off handle while turning counter-clockwise, the brake will prevent the handle from spinning rapidly backwards. **NOTE:** The brake is not fully locked until the handle is turned clockwise far enough to hear two (2) clicks of the ratchet.

WARNING: Sufficient load must be applied to the cable to overcome internal resistance and operate brake properly. **NEVER CONTINUE TURNING THE HANDLE COUNTER-CLOCKWISE IF THE CABLE DOES NOT KEEP MOVING OUT.** This will disengage the brake mechanism and can create an unsafe or hazardous condition. **MINIMUM OPERATING LOAD REQUIREMENTS – Model 5352 – 100 lbs.**

The brake mechanism under continuous long periods of lift and lower movement will get HOT.
DO NOT TOUCH BRAKE MECHANISM UNDER THESE CONDITIONS.

V. MAINTENANCE INSTRUCTIONS

- A. **LUBRICATION.** All gears must be clean and lubricated (auto-type grease) to ensure proper and safe operation. All shafts, bushings and ratchet parts must be clean and wet with oil (auto-type 10W-30) to ensure proper and safe operation.
- B. **BRAKE DISC.** Brake disc wear can be inspected by removing handle retainer assembly, handle and brake disc cover. Brake discs should be replaced if the thickness is less than 1/16”, cracked or broken. **DO NOT USE OIL OR GREASE ON FIBRE BRAKE FACES.**

WARNING: If brake disc mechanism operates intermittently or erratically, brake disc inspection should be accomplished.

- C. **BRAKE RATCHET MECHANISM.** Check ratchet operation by listening for “clicking sound” when cable is reeled in (turn handle clockwise). Also, when the cable is reeled out, there will NOT be a clicking sound of the ratchet. Brake ratchet parts can be inspected for worn parts and unsafe conditions by removing handle retainer assembly, handle and disc cover.

CAUTION: CARE MUST BE TAKEN DURING REASSEMBLY TO ENSURE THAT ALL PARTS ARE INSTALLED CORRECTLY FOR PROPER OPERATION.

VI. PARTS LIST

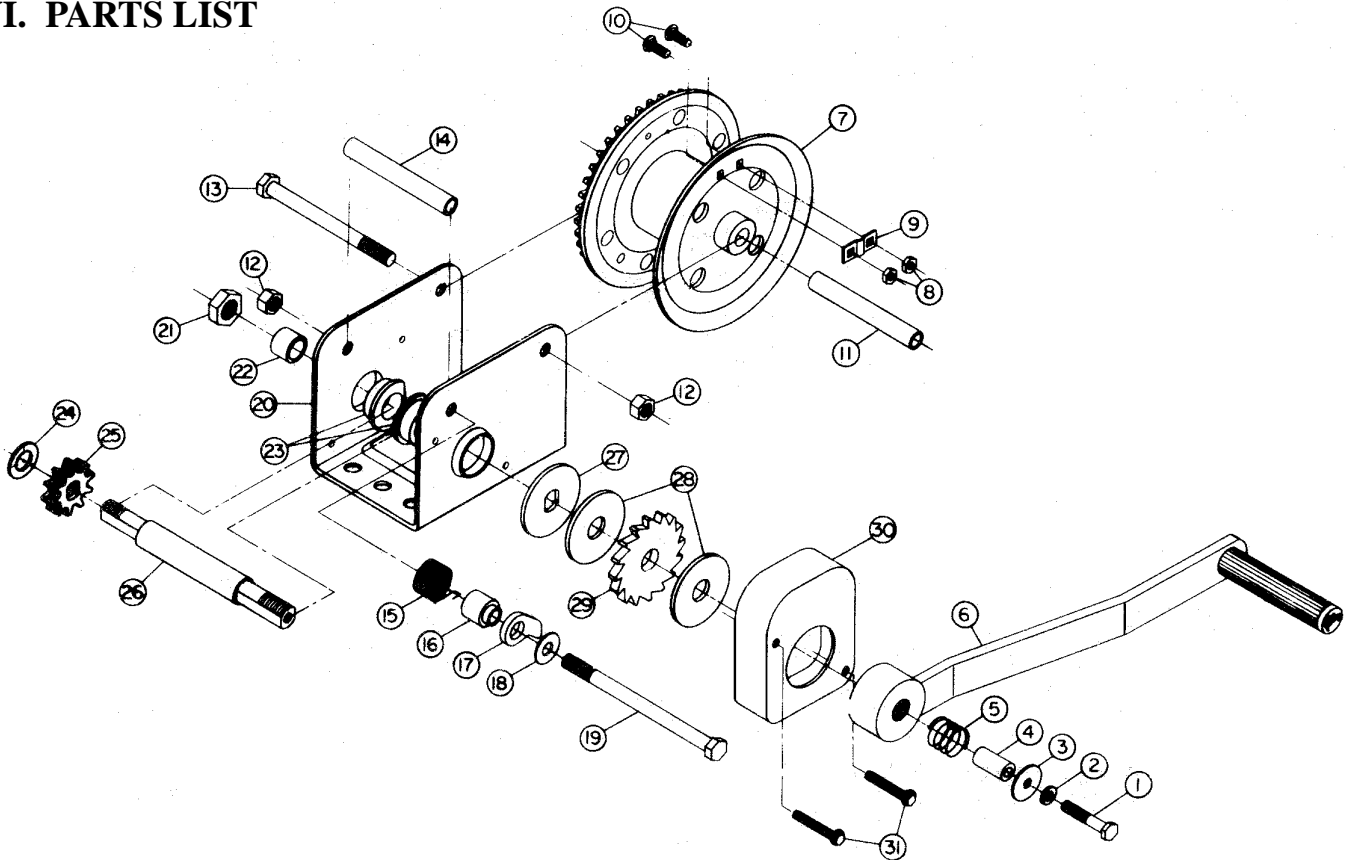

ITEM	DESCRIPTION	PART NO.	KIT NO.
1	1/4"-20 x 1 1/2 Hex screw	0913-03	
2	1/4" Lockwasher	2524-03	
3	1/4" Wide Flatwasher	0917-07	5444-81
4	Handle Retaining Spacer	1907-02	
5	Spring	0940-00	
6	Handle	2089-04	
7	Reel Assembly	0560-05	
8	10-24 Hex Nut (2)	2706-03	
9	Cable Keeper	2704-03	5441-81
10	10-24 x 5/8 Carriage Bolt (2)	2705-03	
11	Front Frame Spacer	2610-02	
12	3/8" Locknut (2)	1873-03	
13	3/8 x 5 Reel Bolt	2625-03	
14	Back Frame Spacer	1867-04	
15	Pawl Spring	1909-05	
16	Pawl Spacer	1890-05	

ITEM	DESCRIPTION	PART NO.	KIT NO.
17	Pawl	1891-07	
18	Washer	0904-03	
19	3/8 x 6 Pawl Bolt	0845-04	
20	Frame	0436-07	
21	9/16 Locknut	0673-03	
22	Bearing	2680-03	
23	Bushing (2)	2679-09	
24	Washer	0229-03	
25	Pinion Gear (5)	0776-03	
26	Pinion Shaft	1870-07	
27	Brake Backup Plate	1878-09	5442-81
28	Brake Pad (2)	0846-06	
29	Ratchet	1906-06	
30	Cover	1915-05	
31	10-32x1 1/2 Cover Screw (2)	2016-03	

- Please order by specifying: Model Number, Name of Part or Kit, Part or Kit Number
- Replacements parts are available from your dealer or the factory.
- If kit number covers a combination of part numbers, parts are sold only by kit number.



CAUTION

THIS WINCH IS NOT DESIGNED TO BE USED FOR HOISTING OR TRANSFER OF PEOPLE OR HOISTING LOADS OVER PEOPLE-OCCUPIED AREAS.

1. NEVER leave a weight hanging by the winch while the winch is unattended, as unauthorized persons may attempt to operate the winch, thereby creating an unsafe condition.
2. NEVER exceed maximum rated line pull (stamped on winch). Exceeding this rating could cause failure of the winch, serious injury to the operator, bystanders and damage to equipment.

NOTE: Maximum rated line pull for Model 5352 is 1500 lbs. (680 kg) for the first layer (minimum of 3 wraps) of line on the drum, and 700 lbs. for full drum rating.

As more line is wrapped on the drum, the mechanical advantage of the winch is reduced and the rating will also be reduced.

3. ALWAYS keep winch maintained in accordance with this instruction sheet. **REMEMBER:** Worn parts cause unsafe conditions.
4. Winch components can be affected by chemicals, salts and rust and should be examined for unsafe conditions before operating.
5. NEVER alter the mechanics of the winch (Example: do not add to the handle length to make easier lifting).
6. NEVER use two or more winch units to lift a load that is greater than the load rating of any single unit. A shifting load may place the entire load on one unit, causing sudden failure of equipment, property damage and serious injury.
7. Apply the load evenly. Do not jerk or bounce the load or allow the load to swing. Avoid violent motion and shock loads. This type of operation requires equipment with higher load ratings.
8. Each time a load is to be lifted, test winch for safe operation by lifting the load a few inches first.
9. ALWAYS keep hands away from load-bearing cables, ropes, sheaves, drums and pulleys while operating.

REMAIN CONSTANTLY AWARE THAT SAFE OPERATING IS YOUR RESPONSIBILITY.

LIMITED WARRANTY

Shelby Industries, Division of Prospects Boat Works, Incorporated warrants its products described herein to be free from defects in material and workmanship to the original purchaser at the date of purchase at retail. If any of these products is found to be defective, it may be replaced or repaired, at the option of Shelby, when returned with proof of purchase to Shelby's manufacturing facility in Shelbyville, Kentucky. The owner shall pay all transportation and shipping charges associated with the return of said product and the returned product shall become the property of Shelby. Where Shelby determines that circumstances are such as to preclude the remedying of warranted defects by replacements or repair, Shelby shall, upon return of the products and proof of purchase, refund owner's purchase price.

In no instance shall Shelby be responsible to repair or replace a product under this limited warranty where said product was improperly installed, altered or misused, including using the product contrary to Shelby's printed instructions or instructions stamped on the product itself.

The foregoing states the sole and exclusive remedy for any breach of warranty or for any other claim based on any defect in or non-performance of, the products, whether sounding in contract, warranty or negligence or strict liability. Shelby makes no other warranties express or implied, hereby excludes any implied warranties of mechanability or fitness.

Without limiting the generality of the foregoing, Shelby shall under no circumstances be liable for any incidental or consequential loss or damage whatsoever arising out of, or in any way relating to, any such breach of warranty or claimed defect in, or non-performance of, the products.

This limited warranty is designed to fully comply with the terms and provisions of the Magnuson-Moss Warranty Act. Some states may not allow the limitation of exclusion of incidental or consequential damages, so the above limitations or exclusions may not apply to you.

For more information or assistance regarding this product, contact your dealer or write to: Customer Service Manager, Shelby Industries, Division Boat Works, P.O. Box 308, Shelbyville, Kentucky 40065.

NOTE: THIS PRODUCT COMPLIES WITH REGULATION V-5 AND C.S.A. STANDARD D-264

NOTE: SOME STATES REQUIRE CLEAR VIEW OF LICENCE. REMOVE BALL WHEN NOT IN USE IF IT RESTRICTS VIEW.

NOTE: THIS PRODUCT COMPLIES WITH SAFETY SPECIFICATION & REQUIREMENTS FOR CONNECTING DEVICES & TOWING SYSTEMS OF THE STATE OF NEW YORK.