

SUPERCHUTE® DEBRIS REMOVAL SYSTEM

CHUTE HOIST INSTALLATION MANUAL

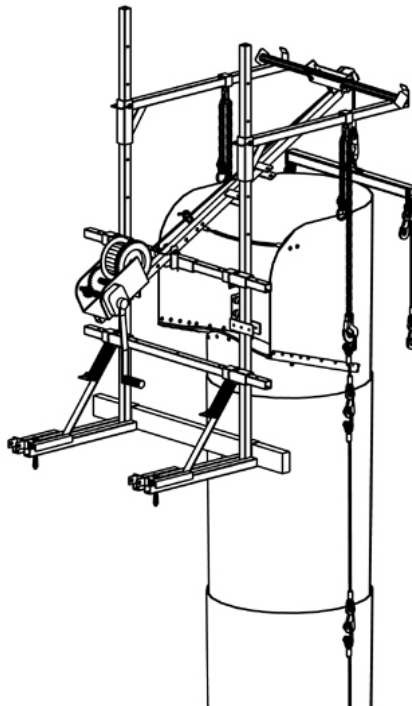

**IMPORTANT REFERENCE
DOCUMENT**

For Bolt-Down Frame Model N° SC-500-bd

SUPERCHUTE® FACTORY

- toll free: 800-363-2488
- telephone: 514-365-6121
- facsimile: 514-365-8987
- internet: www.superchute.com
- e-mail: info@superchute.com
- address: 8810 Elmslie Road, Montreal, Canada, H8R 1V6

Edition of Sept 3, 2013

IMPORTANT NOTICE:

IT IS THE RESPONSIBILITY OF COMPANIES THAT SELL, RENT OR USE THE SUPERCHUTE® PRODUCT TO FREELY SUPPLY THE LATEST EDITION OF THIS MANUAL TO THE FOLLOWING PERSONS:

- **THE PLANNERS AND SUPERVISORS OF THE CHUTE SYSTEM**
- **THE INSTALLERS OF THE CHUTE SYSTEM**
- **THE USERS OF THE CHUTE SYSTEM**

If you have any questions or comments concerning this manual, please feel free to contact Superchute Ltd.

The contents of this manual remain the intellectual property of Superchute Ltd. Superchute Ltd. authorizes reproduction (photocopies or similar) of all of its safety manuals, provided the reproduction is intended for users of the Superchute® product. Reproductions must be made in their entirety.

*© Superchute Ltd., 1999
All Rights Reserved
Printed in Canada*

This manual refers to the following products, which are protected by international patent laws:

Door Sections	Wraparound® Regular Sections	Chute Hoists
U.S. Pat. No. Des. 328,174 Can. Ind. Des. 1990 RD 66842	U.S. Pat. 5,472,768 Can. Pat. 2,119,108 U.K. Pat. 2,276,151	U.S. Pat. 5,934,437 Can. Pat. Application 2,177,741



WARNING

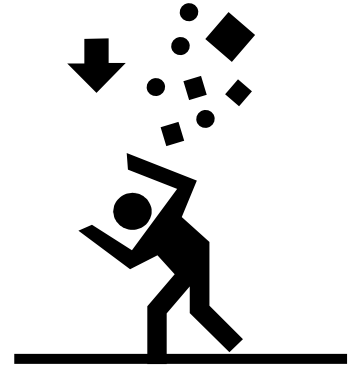
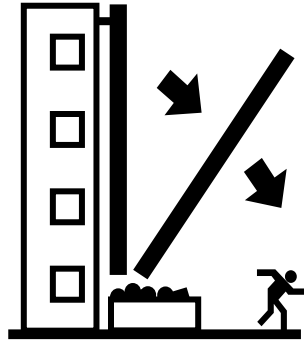
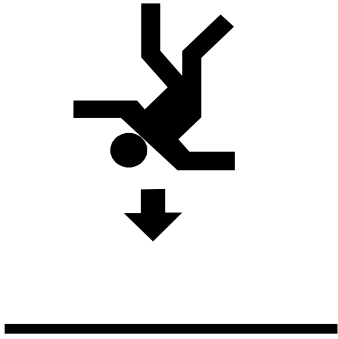

- The installation and use of a Superchute Chute System involves many hazards, for example, the risk of:
 - a worker falling off a building
 - a blockage in the chute causing the chute system to collapse
 - a person being struck by falling debris
- Failure to follow Superchute's instructions may result in serious injury or death.
- Planners, Supervisors, Installers, and Users must read, understand, and follow the instructions found in these manuals before rigging or using a chute system:
 1. The "Chutes Manual"
 2. The applicable "Chute Hoist Installation Manual(s)"
- For copies of these manuals contact Superchute® Ltd: 1-800-363-2488 or download them from www.superchute.com

HOW TO USE THIS MANUAL

Many people read this manual from beginning to end when they first receive their chute hoist. The manual explains the hoist's features and the procedures for using it safely.

In this manual, you'll find that pictures and words work together to explain things quickly.

A) USE THE MOST RECENT EDITION

- Each new edition of the SC-500-bd Chute Hoist Installation Manual contains important new information.
- **ALWAYS USE THE MOST RECENT EDITION:** Compare the edition date of this booklet (printed at the bottom of every page) to the edition available for download on the Superchute website: www.superchute.com. Use the edition with the most recent date. If you do not have access to the internet, call Superchute (1-800-363-2488) and ask a representative for assistance.
- The instructions in a new edition supersede any instruction found in a prior edition.
- Avoid confusion: discard any old SC-500-bd Chute Hoist Installation Manuals.

B) IF USING THIS MANUAL EDITION WITH AN OLDER HOIST

Over time, improvements have been made to the Bolt Down Frame. If you are using this manual with an older hoist, you may find some of the sketches do not match the product you have. If you are unsure of how to proceed, call the Superchute® Factory: 1-800-363-2488.

Older hoists can be upgraded to reflect the latest improvements. Contact the Superchute® factory for details.

C) USE THE TABLE OF CONTENTS

A good place to look for what you need is the Table of Contents located on **page 6** of the manual. It's a list of all that's in the manual along with the page number where you'll find it.

D) SAFETY WARNINGS AND SYMBOLS

You will find a number of safety warnings in this book. Safety warnings tell you about things that could hurt you, or others, if you were to ignore the warning. We use the following symbol to attract your attention to the warning:



A warning indicates a potentially hazardous situation which, if not avoided, could result in death or serious injury.

Here is an example of a Superchute® warning:

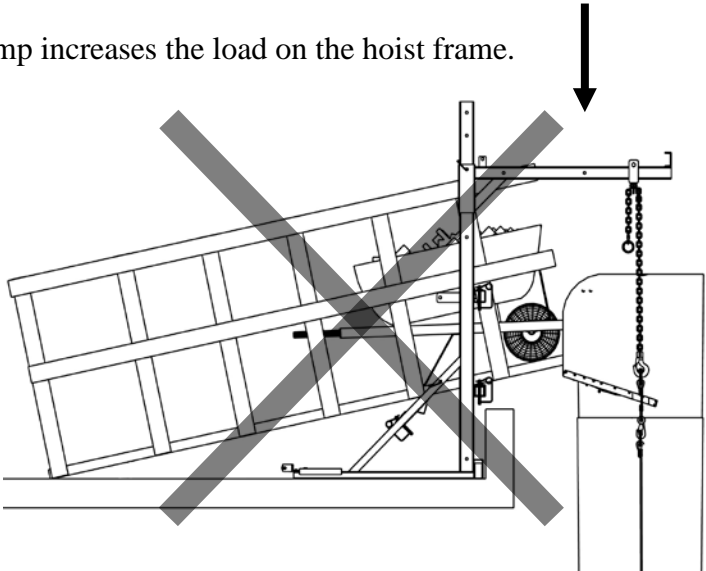
 WARNING	
Hazard	<ul style="list-style-type: none">• A ramp resting on the hoist frame could greatly increase the loading on the hoist frame.• The load increase could cause the hoist frame to fail.• Do NOT rest ramps on the hoist frame. Do NOT attach ramps to the hoist frame. Ramp designs must be approved by a structural engineer.
Consequence	
Instruction	
Pictorial (optional)	<p><u>WRONG:</u></p> <p>The wheelbarrow ramp increases the load on the hoist frame.</p> 

E) STORE THE MANUAL IN THE SUPERCHUTE DOCUMENTS CANISTER

Use a canister at the jobsite to:

- protect and store the manual.
- make the manual readily available to users of the Hoist.

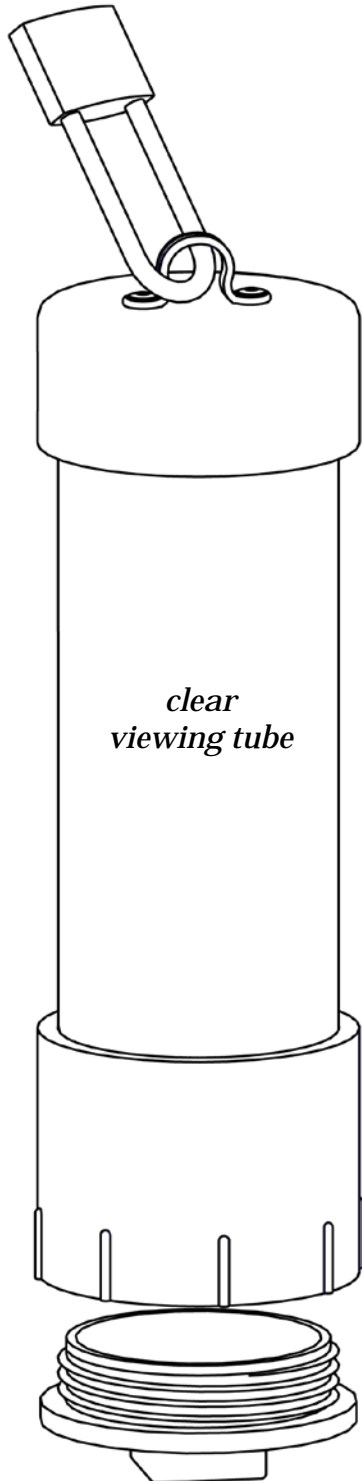

The canister is virtually indestructible and weatherproof. It features a clear plastic viewing tube that allows users to see its contents. The canister is supplied with a brass padlock to allow it to be locked to the hoist.

An on-site canister protects your workers and your company by ensuring greater jobsite safety. Use the canister as part of your overall safety program.

Color pictures with more explanations are provided on the Superchute website: www.superchute.com.

TABLE OF CONTENTS

HOW TO USE THIS MANUAL.....	3
1. INTRODUCTION.....	7
2. IDENTIFY THE PIECES	8
3. DIMENSIONS.....	14
4. NORMAL LOADS	16
5. ULTIMATE LOADS	18
6. IMPORTANT INFORMATION.....	20
7. ASSESS CHUTE HEIGHT & WEIGHT	22
8. CHUTE SECTION WEIGHT CHARTS	24
9. ASSEMBLY OF THE FRAME	25
10. A FEW FALL PROTECTION REGULATIONS.....	29
11. SECURE THE FRAME.....	30
12. PREPARE THE HOLES FOR THE ANCHOR BOLTS	31
A) BEFORE DRILLING THE HOLES.....	31
B) DRILL THE HOLES	32
C) HOLE ALIGNMENT.....	33
13. ANCHOR THE FRAME TO THE CONCRETE SLAB.....	34
14. THE COUNTERWEIGHT KIT.....	36
15. ATTACH THE BOOMS	39
16. TOEBOARD BRACKETS	40
17. PREPARE & INSTALL THE FISHPOLE (if applicable)	41
18. HOIST THE CHUTE SECTIONS INTO PLACE.....	47
19. TRANSFER THE CHUTE LOAD FROM THE LIFTING DEVICE TO THE BOOM CHAINS	53
20. REMOVE THE FISHPOLE (if applicable)	55
21. CONGRATULATIONS!	57
22. FALL PROTECTION & THE GATEKEEPER	58
23. RAMPS	59
24. PIGGYBACKING	60
25. PIGGYBACKING - SPECIAL CONSIDERATIONS.....	61
A) USE A RESTRAINT TO KEEP CHUTE LENGTHS FROM KISSING	61
B) DO NOT LINK CHUTE LENGTHS USING THE CABLE ASSEMBLIES	62
C) LEAPFROG THE TOP HOPPER ON A GROWING BUILDING	64
D) OVERVIEW OF THE LEAPFROG PROCEDURE:.....	65
26. DE-INSTALLATION OF THE HOIST	66
APPENDIX A: WARRANTY.....	67
APPENDIX B: STAY INFORMED	67
APPENDIX C: PARTS LIST	68
APPENDIX D: FACTORY CERTIFICATE.....	70
APPENDIX E: GLOSSARY.....	71
APPENDIX F: WINCH INFORMATION (IF APPLICABLE)	72

1. INTRODUCTION

Welcome to safe, quick, and easy chute installations!

The Bolt-Down Frame is a simple chute hoist that attaches to a concrete floor slab using 2 expansion anchor bolts (supplied). In cases where drilling into the floor is not possible, the Frame can be secured using a Counterweight Kit (sold separately).

Superchute Ltd manufactures three models of Bolt-Down Frame: the SC-250-bd, SC-500-bd, and SC-750-bd. This installation manual concerns model SC-500-bd, which lifts, supports, and lowers up to 500 lb. of chute. A 500 lb. chute load translates into approximately 40 feet (12 chute sections) – The length of chute that can be created depends on the total weight of the chute, which must be calculated (refer to **Section 7** in this manual entitled: **Assess Chute Height & Weight**).

The design features a 3:1 safety factor.

The frame ships and stores as a neat, compact rectangular packet. It is assembled in less than 5 minutes, using just 6 locking pins. A removable Fishpole is available for lifting and lowering the chute. The same Fishpole can serve many SC-250-bd and SC-500-bd frames.

Built-in storage tubes hold 2 expansion anchor bolts. There are no loose pieces whatsoever.

On jobs where a taller chute is needed, frames can be piggybacked approximately every 40 feet (depending on the chute diameter used) in order to achieve a maximum chute height of 200 ft.

Understand the Name:

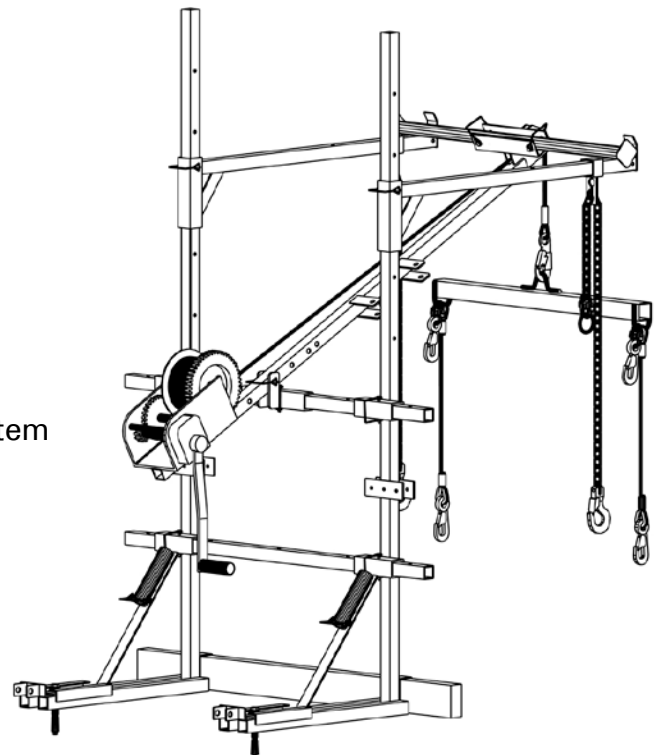
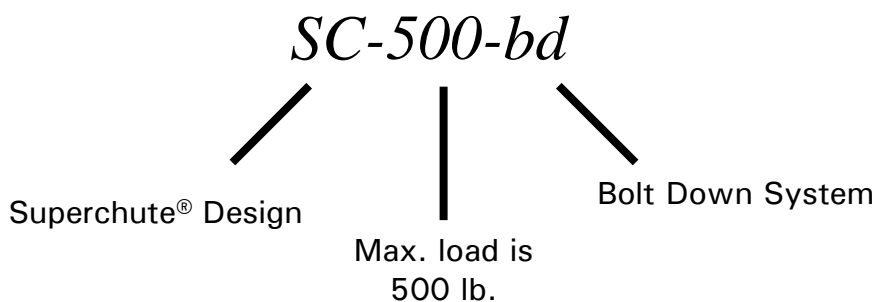

2. IDENTIFY THE PIECES

Frame Pieces

2 Expansion
Anchors

8 Pins

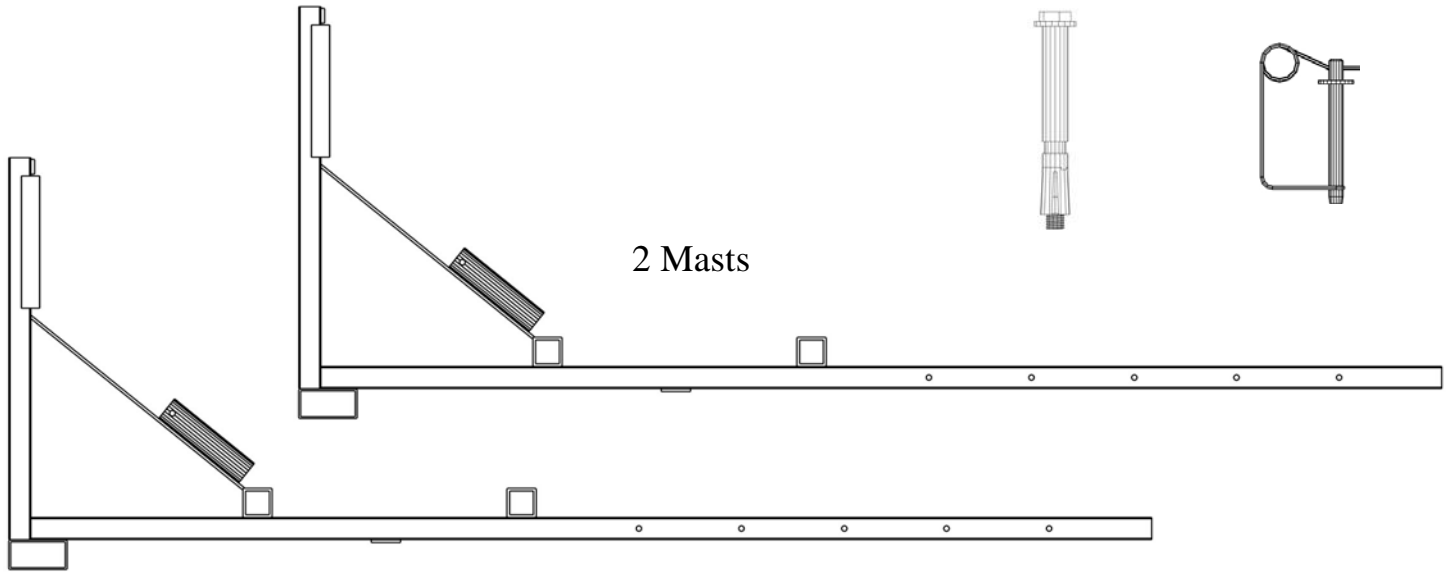

2 Booms with chains

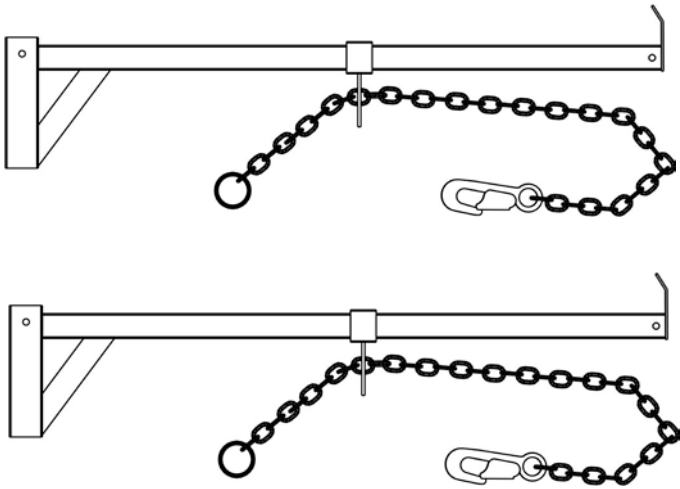

Spreader Bar
(1 per order)

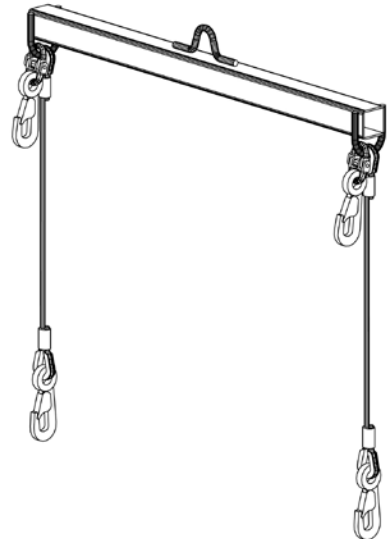

2 Tie Bars



Standard Hoisting Device (F-250/500)

1 Standard Fishpole equipped with:

- Shelby drum winch
- 90' cable & hook
- sheave wheel
- 4 locking pins

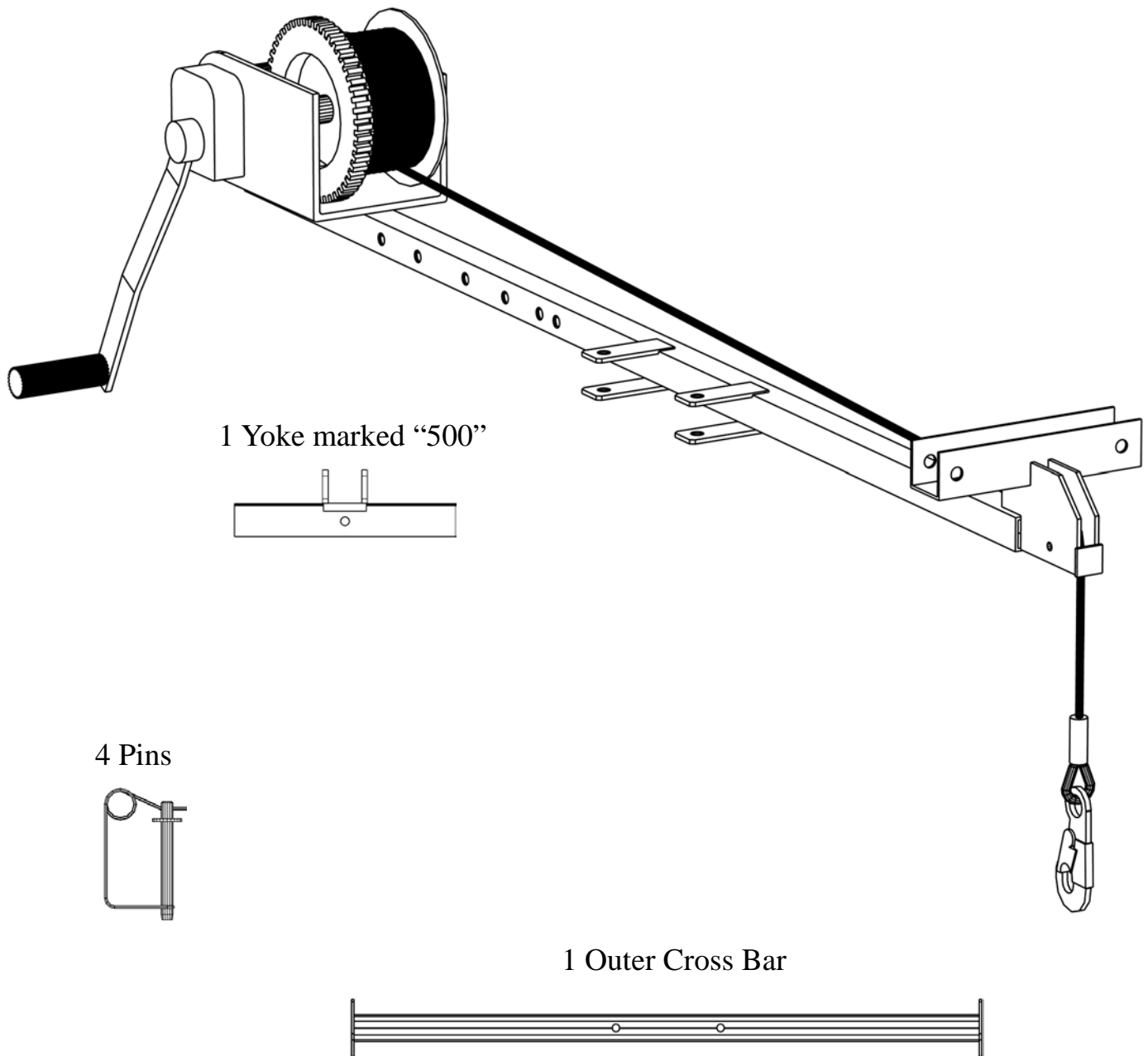

Special Hoisting Device (F-250-X)

For tall jobs: 1 Fishpole equipped with:

- Griphoist®-Tirfor® winch model T-508
- Winch handle
- 150 ft cable with hook
- Cable reeler
- Sheave wheel

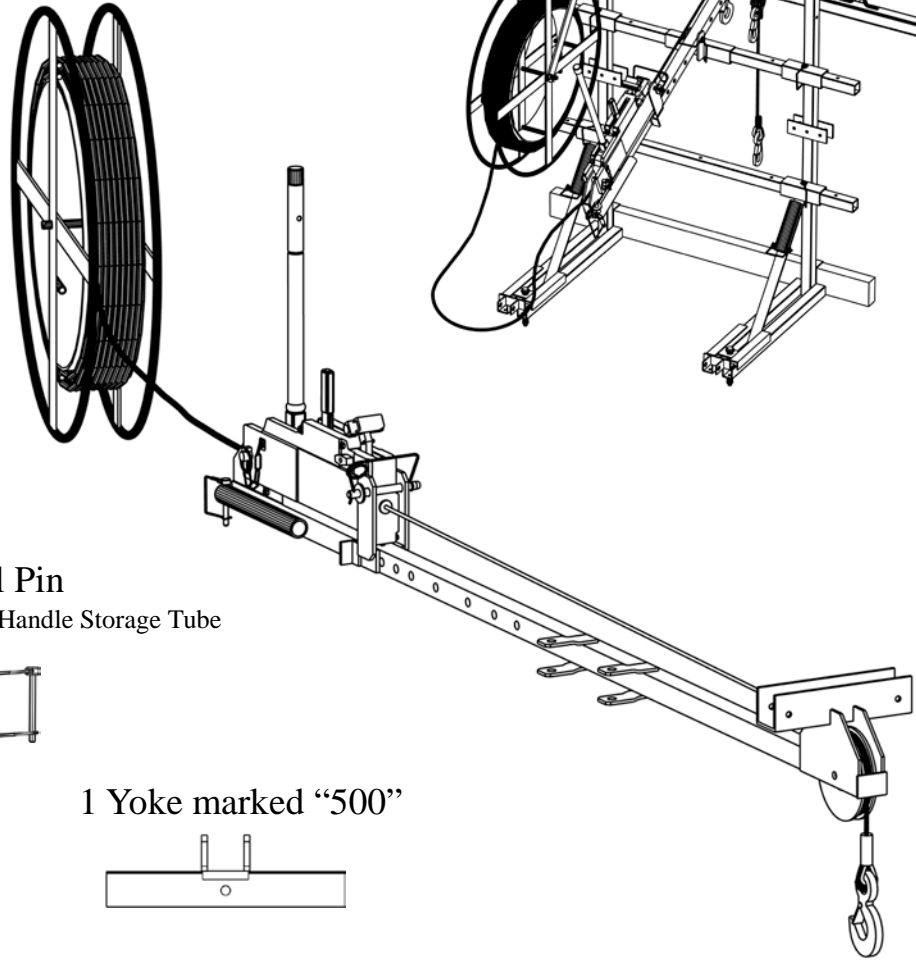
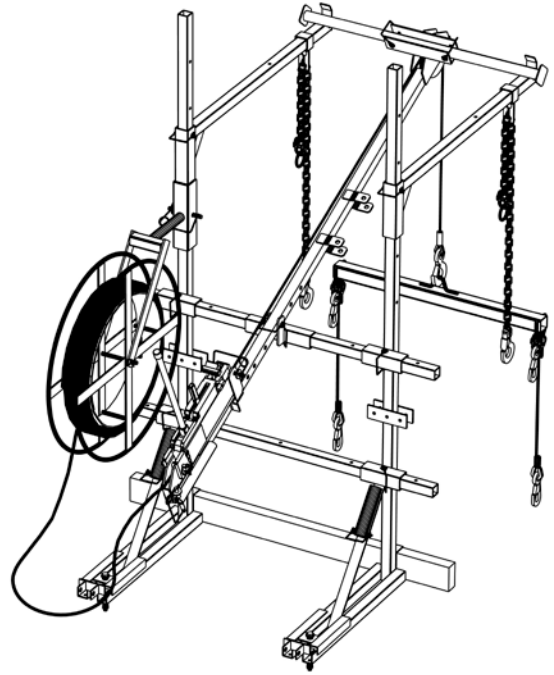

6 large Pins

- 2 for the Yoke
- 2 for the OCB
- 1 for the Winch bracket
- 1 for the Reeler Hanger

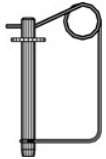

1 small Pin

- for the Handle Storage Tube



1 Yoke marked "500"

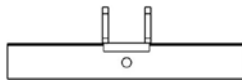

Booklet containing winch instructions:
 "Tirfor – Operating and Maintenance Instructions"



1 Outer Cross Bar

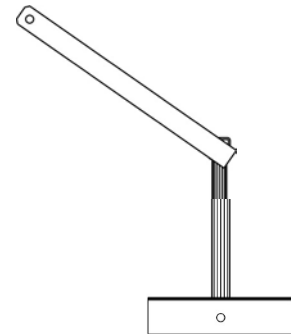

1 Reeler Hanger

Optional Components:

The Weight Kit

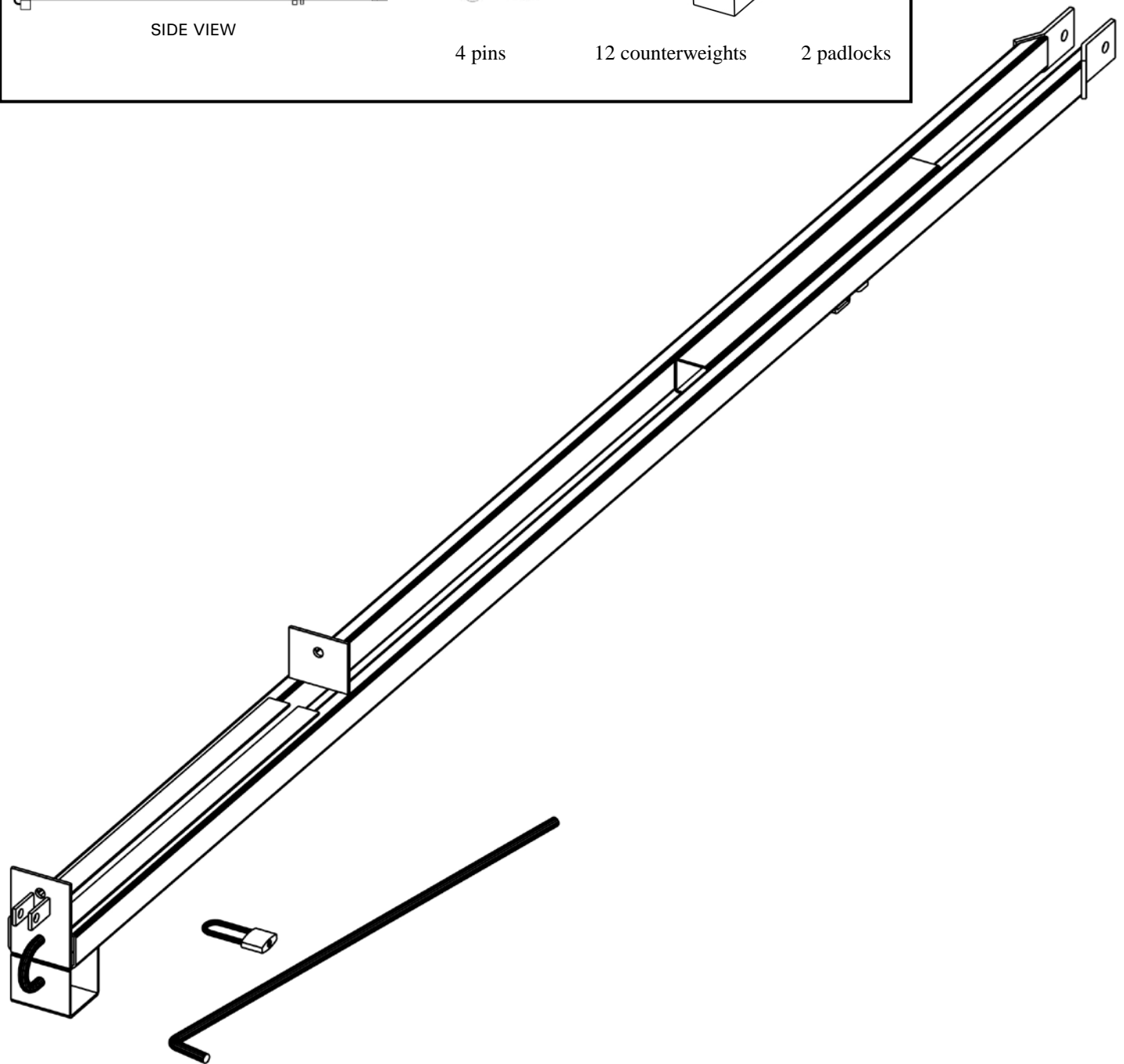
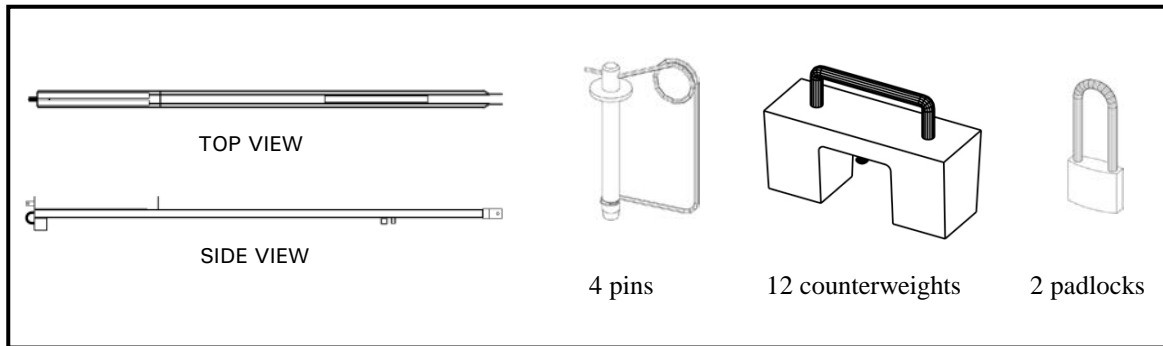

Tie-Backs for the Weight Kit

In the event of a blockage (or similar) tie-backs will help prevent the hoist from being pulled over the edge of the supporting structure.

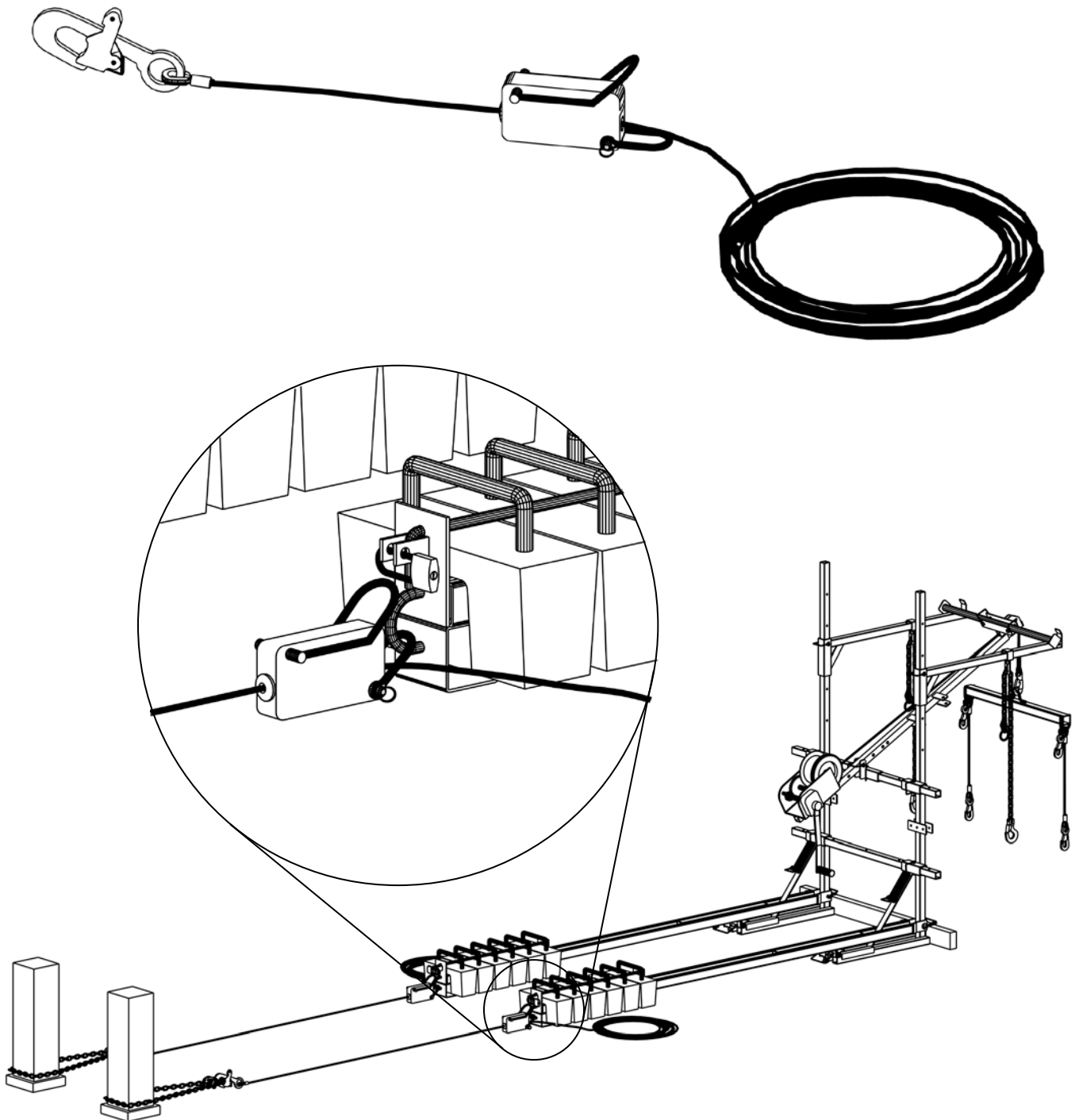

Exploded View

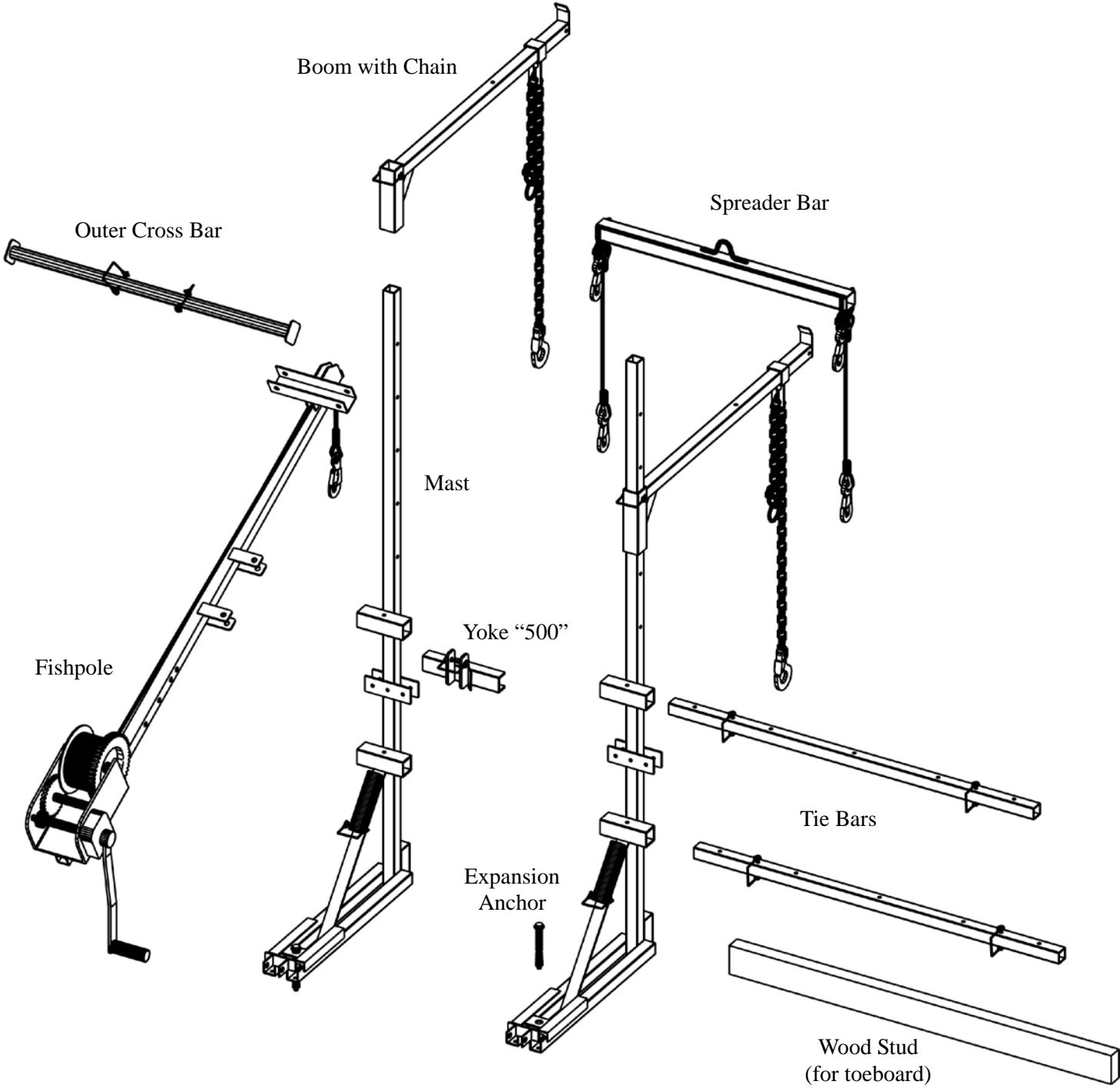

3. DIMENSIONS

WHEN BOLTED TO THE SLAB

- Frame Weight: 190 lb.
 - Fishpole Weight: 70 lb.
- Total Weight: 260 lb.

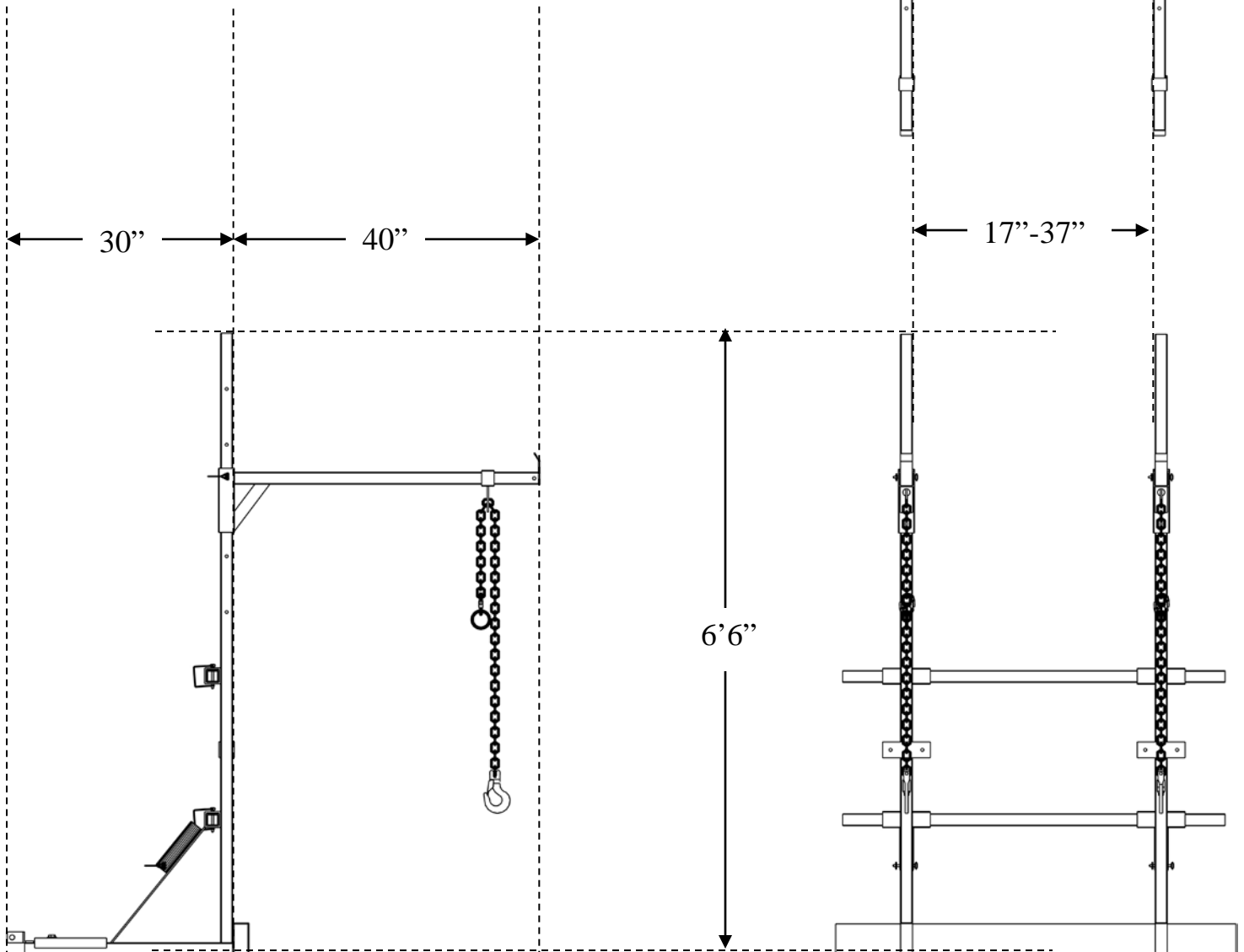

WHEN COUNTERWEIGHTED

- Frame Weight: 190 lb. (excluding counterweights)
- Fishpole Weight: 70 lb.
- Counterweights: 660 lb. (12 required x 55 lb each)
- Weight Beams: 110 lb.

Total Weight: 1030 lb.

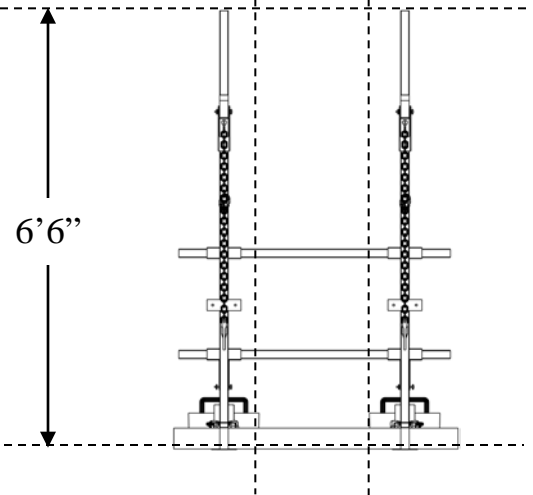
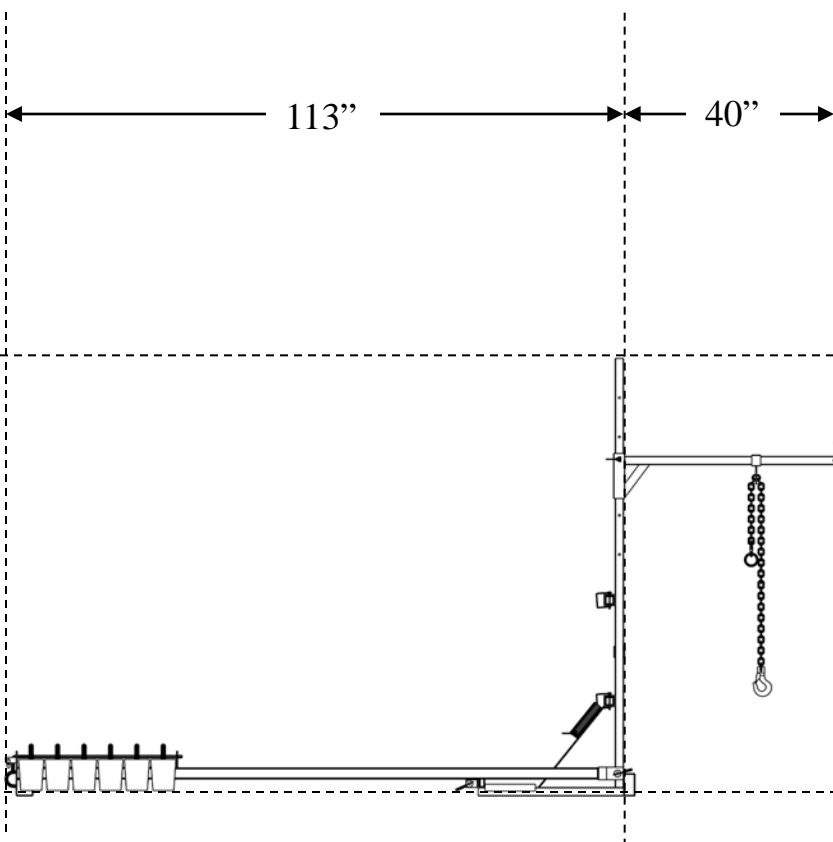
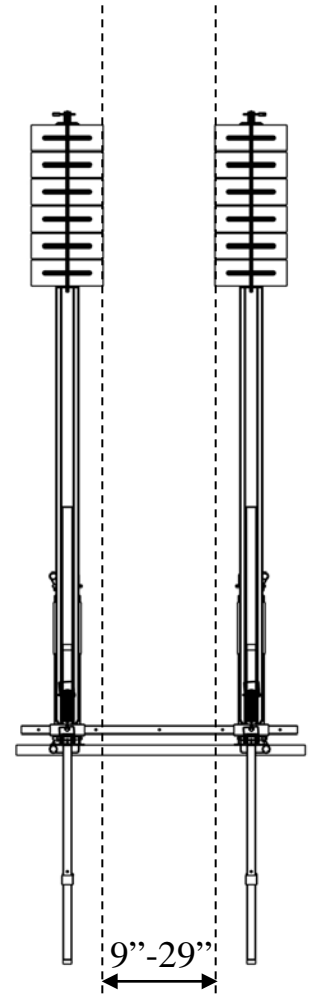

4. NORMAL LOADS

Secured using 2 Factory-Approved Expansion Anchor Bolts

The sketch shows the loads imposed on the supporting structure with normal use.

A structural engineer must verify the adequacy of the supporting concrete slab.

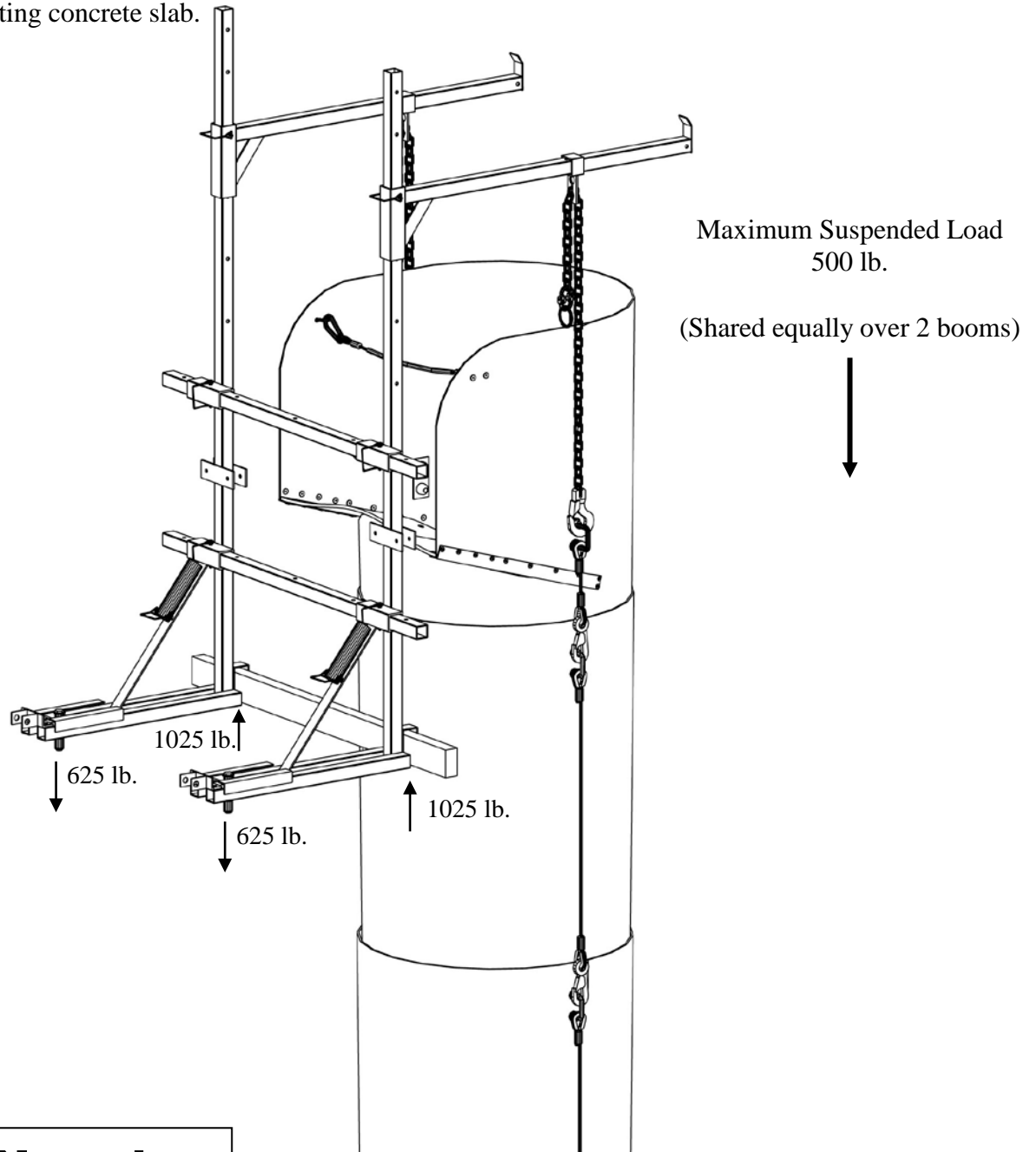

**Showing Normal
Applied Loading**

Secured using 2 Counterweighted Extensions (instead of Expansion Anchor Bolts)

The sketch shows the loads imposed on the supporting structure with normal use.

A structural engineer must verify the adequacy of the supporting floor.

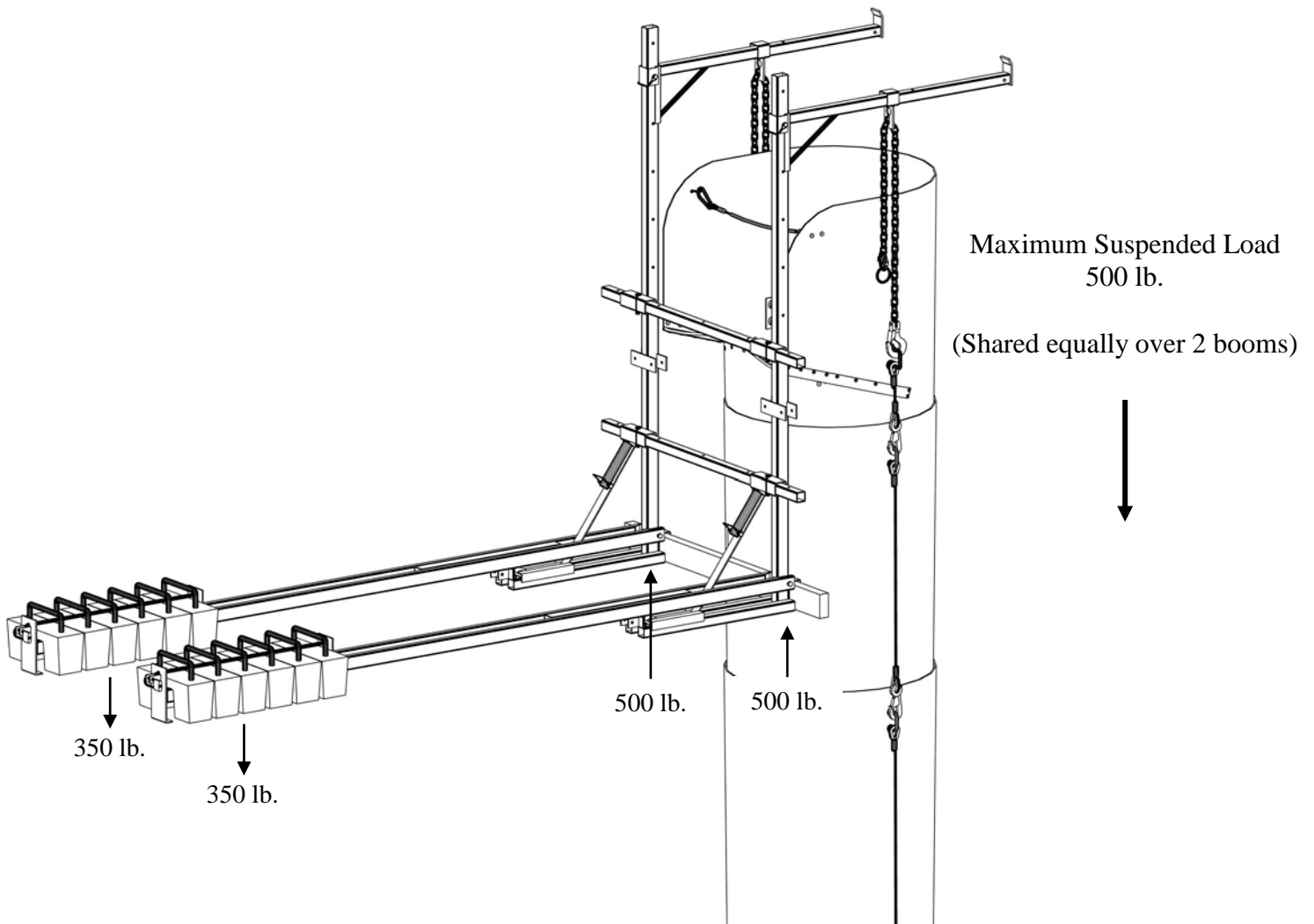

**Showing Normal
Applied Loading**

5. ULTIMATE LOADS

**Secured using 2 Factory-Approved
Expansion Anchor Bolts**

The sketch shows the loads imposed on the supporting structure when the device is overloaded.

A structural engineer must verify the adequacy of the supporting concrete slab.

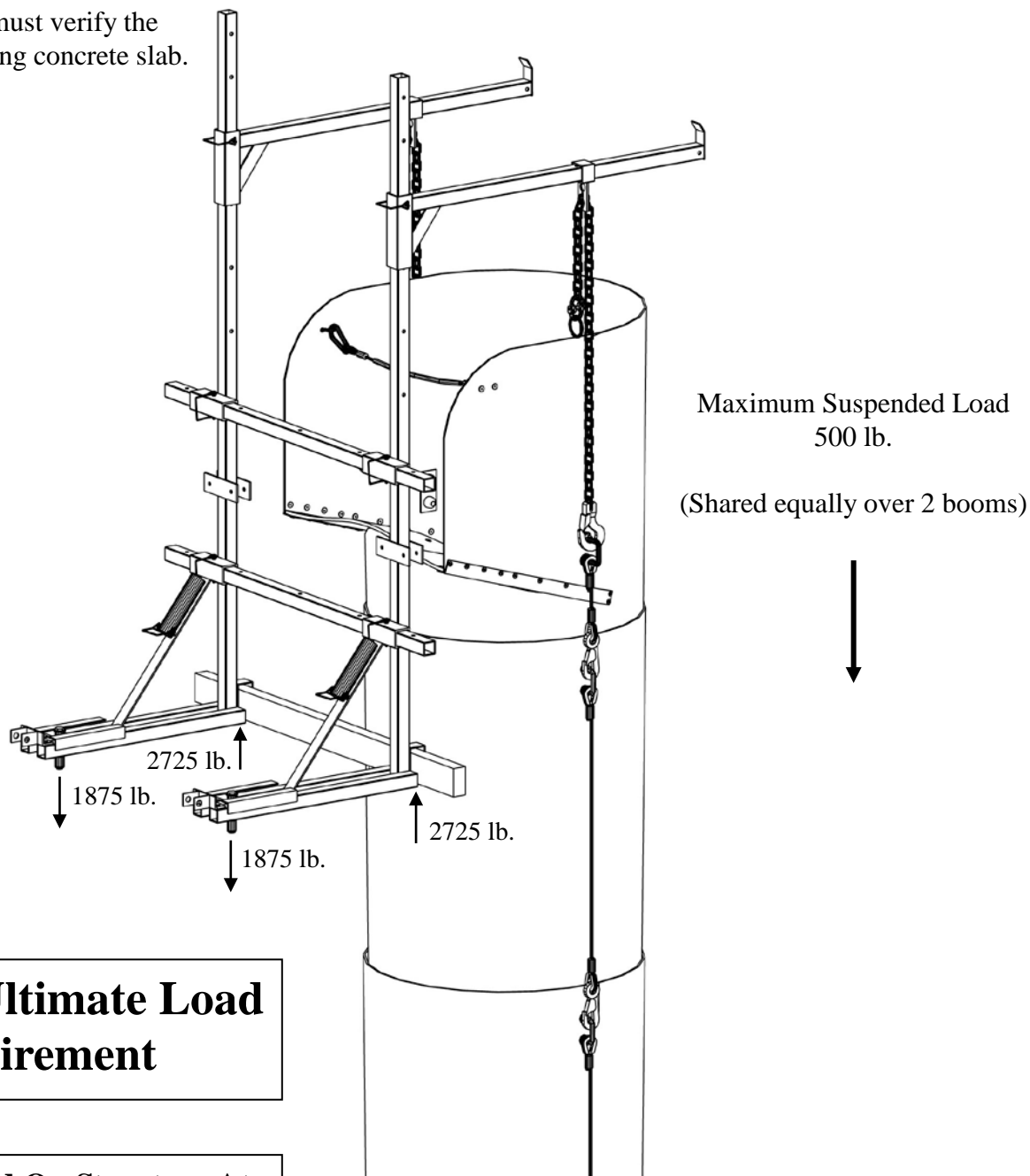

**Showing Ultimate Load
Requirement**

**Loads Imposed On Structure At
3:1 Stability Factor**

Secured using 2 Counterweighted Extensions (instead of Expansion Anchor Bolts)

The sketch shows the loads imposed on the supporting structure when the device is overloaded.

A structural engineer must verify the adequacy of the supporting floor.

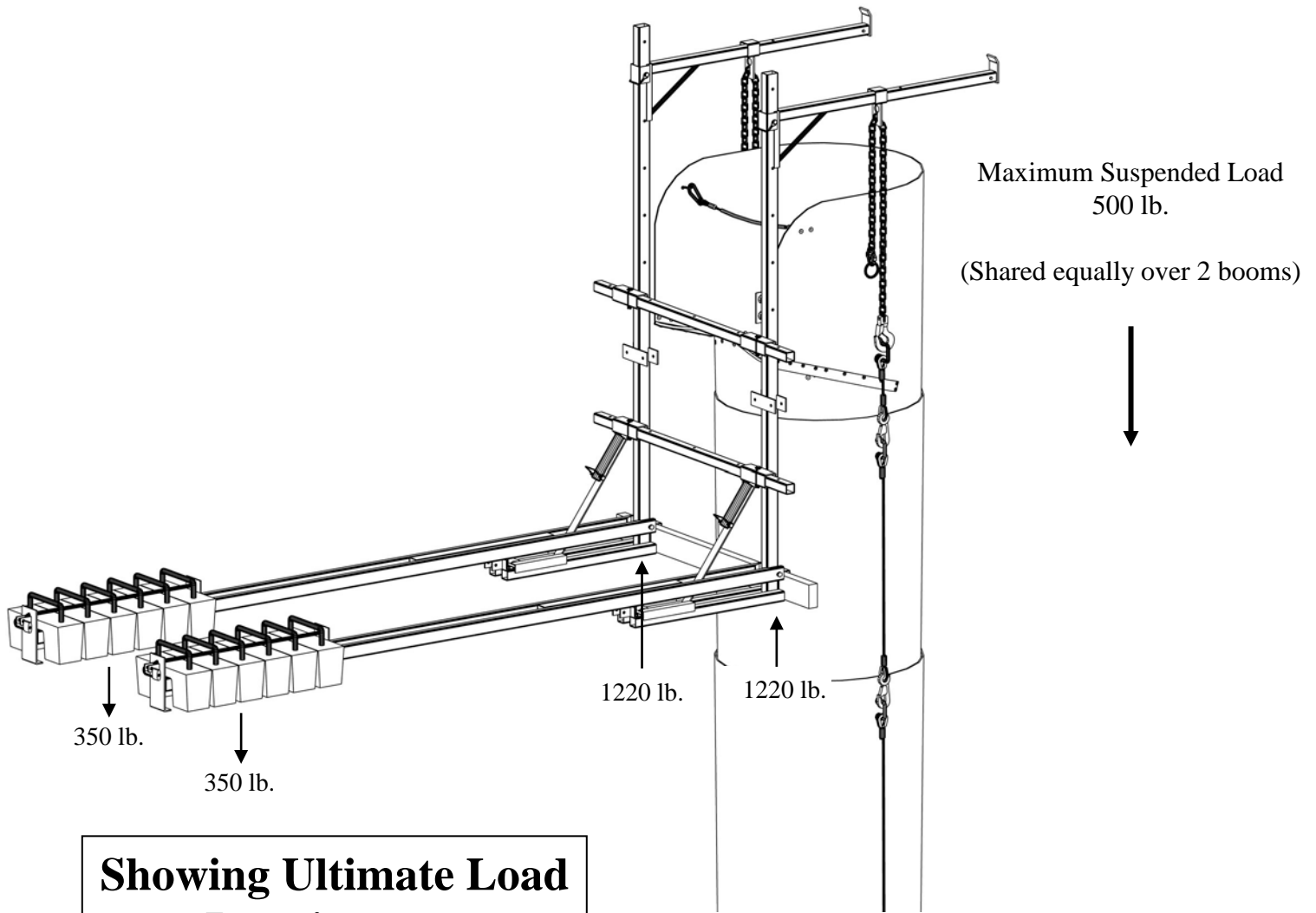

Showing Ultimate Load Requirement

Loads Imposed On Structure At 3:1 Stability Factor

6. IMPORTANT INFORMATION

Applicable Regulations

Before rigging or using the chute system, planners, supervisors, installers and users should be aware of applicable federal, state, and local safety regulations.

Additional Expertise

This manual should not be taken as an overall survey on rigging technique, fall protection, or structure appraisal. Whenever these considerations arise, the planners, supervisors, installers and users of the chute system should secure the services of trained professionals.

Availability of the Manual

Planners, supervisors, installers and users of the chute system must be able to refer to this manual at any time. Copies of this manual are available from Superchute Ltd. free of charge, **by mail or fax, and can be downloaded from the Superchute® web site at: www.superchute.com.** If this manual is not with the chute system on the job site, postpone installation and use of the chute system until a manual is obtained.

Condition of the Equipment

Every time the chute is to be rigged or used, make sure the following items are in good condition: Superchute® hoist(s), Superchute® cable assemblies, Superchute® chute sections, Superchute® steel liners, and any other ancillary Superchute® equipment, such as door adjustment kits and tie-back kits. Thorough overhaul servicing is available from Superchute Ltd.

Condition of the Workers

Superchute® equipment should only be used by workers who are fit to operate it in a responsible manner.

Corrosive Substances

Keep corrosive substances away from all hoist components.

Engineered Rigging Equipment

Use engineered rigging equipment to install and anchor chute sections (for example, a Superchute® chute hoist).

Fire Prevention

Do not weld or flame-cut within 20 ft. of the hoist or chute.

Help Line

If at any time you are unsure of how to proceed call Superchute Toll Free: 1-800-363-2488

Intent of the Product

Do not use the chute hoist to lift or lower materials other than a Superchute® trash chute. Do not use the chute hoist as a man-hoist.

Lightning Storm

During a lightning storm stay away from the hoist & suspended chute system.

Other Brands of Chute

Do not mix Superchute® chute sections with chute sections of another brand.

Parts

Do not replace original Superchute® parts with non-Superchute® parts.

Powered loaders

Do not use powered loaders to introduce debris into the chute.

Prevent Electrocutation

Install the hoist and chute in an area free of electric cables. If cables are present contact your local electrical authority before proceeding.

Structural Engineer

Before a chute installation begins, a structural engineer must verify the adequacy of the supporting structure.

Training

A one-day training seminar is offered free of charge at the Superchute® factory. The seminar examines the proper installation and use of Superchute® chute sections and chute hoists. Call 1-800-363-2488 for details.

7. ASSESS CHUTE HEIGHT & WEIGHT

SAMPLE

- The first step in undertaking a chute installation is to formulate an installation plan.
- This page is a planning tool, which is used here to illustrate an imaginary chute job.
- The next page is clean and is for your own use. Photocopy it and use it to plan your chute installations.

JOB NAME: Hotel On First Ave.

1. What is the anticipated height of the chute? 100' feet.
The maximum allowable height of a chute is 200 ft.

$$100 \text{ feet} \times 3 \text{ divided by } 10 = 30$$

2. How many chute sections will be needed? Height in ft x 3 ÷ 10 = 30 sections.
When linked, 3 chute sections of any type will create a 10 foot drop.

3. What diameter of chute will be used? [18"] [23"] [27"] [30"] [33"] [36"]
Every chute section is branded with its diameter.

4. Calculate the total weight of the chute system using the form below:
Every chute section is branded with its weight.
Section Weights are also provided on [page 24](#).

Chute Weight Calculation Form

(A) 1 Top Hopper x 42 lb. each = 42 lb.
 Wraparound

(B) 2 Door Sections x 52 lb. each = 104 lb.
 Wraparound

(C) 27 Regular Sections x 39 lb. each = 1053 lb.
 Wraparound - 3/16" wall

(D) 2 Steel Liners x 40 lb. each = 80 lb.

A + B + C + D = The Total Weight Of The Chute System = 1279 lb.

5. How many SC-500-bd frames will be needed to handle the total weight.
Divide the total weight of the chute system by 500, and round up. This is your answer.

$$1279 \text{ lb. divided by } 500 \text{ lb. of Capacity per frame} = 2.6 \text{ frames}$$

3 Frames Needed

ASSESS CHUTE HEIGHT & WEIGHT – Photocopy this page

Before the chute is rigged it's height and weight must be calculated. Photocopy this form and use it with the weight charts provided on the next page. Knowing the total weight of the chute allows the installer(s) to choose an appropriate lifting device and suitable anchors. If at any time you would like to discuss the particulars of your job situation, please feel free to call the Superchute® factory: 1-800-363-2488.

JOB NAME: _____

1. What is the anticipated height of the chute? _____ feet.
The maximum allowable height of a chute is 200 ft.
2. How many chute sections will be needed? Height in ft x 3 ÷ 10 = _____ sections.
When linked, 3 chute sections of any type will create a 10 foot drop.
3. What diameter of chute will be used? [18"] [23"] [27"] [30"] [33"] [36"]
Every chute section is branded with its diameter.
4. Calculate the total weight of the chute system using the form below:
Every chute section is branded with its weight.
Section Weights are also provided on the next page.

Chute Weight Calculation Form

(A)	<u>1</u>	Top Hopper	x	_____ lb. each	=	_____ lb.
(B)	_____	Door Sections	x	_____ lb. each	=	_____ lb.
(C)	_____	Regular Sections	x	_____ lb. each	=	_____ lb.
(D)	_____	Steel Liners	x	_____ lb. each	=	_____ lb.
A + B + C + D = The Total Weight Of The Chute System					=	_____ lb.

5. How many SC-500-bd frames will be needed to handle the total weight.
Divide the total weight of the chute system by 500, and round up. This is your answer.

8. CHUTE SECTION WEIGHT CHARTS

- An “x” signifies that no such section exists.
- If using steel liners, do not forget to account for their weight.

WELDED SECTIONS WEIGHTS (in lb.)

Diameter	Wall Thick.	Regular	Top Hopper	Door
18”	5 mm	23	24	29
23”	5 mm	27	30	36
27”	5 mm	32	34	41
30”	5 mm	37	40	47
30”	4 mm	27	X	X
30”	3.2 mm	X	X	X
33”	5 mm	40	42	50
36”	6 mm	48	53	60

WRAPAROUND® SECTIONS WEIGHTS (in lb.)

Diameter	Wall Thick.	Regular	Top Hopper	Door
18”	5 mm	X	X	X
23”	5 mm	29	30	40
27”	5 mm	35	40	49
30”	5 mm	39	42	52
30”	4 mm	31	X	X
30”	3.2 mm	28	X	X
33”	5 mm	43	48	57
36”	6 mm	49	57	68

LINER WEIGHTS (in lb.)

18”	23”	27”	30”	33”	36”
23 lb.	32 lb.	37 lb.	40 lb.	48 lb.	53 lb.

9. ASSEMBLY OF THE FRAME

- Start with a folded frame packet.
- Unclip the chains.
- Split the packet into 2 half frames by releasing the 2 corner pins.

Pin Information:

- 6 pins are required to assemble and use the FRAME.
- 2 spare pins are provided with every frame.
- 4 pins are required to assemble and use the Standard FISHPOLE.
- 6 pins are required to assemble and use the Special FISHPOLE.
- All of the pins used on the SC-500-bd hoist are identical:

Diameter:	1/2"
Overall Length:	5"
Usable Length:	3 1/2"

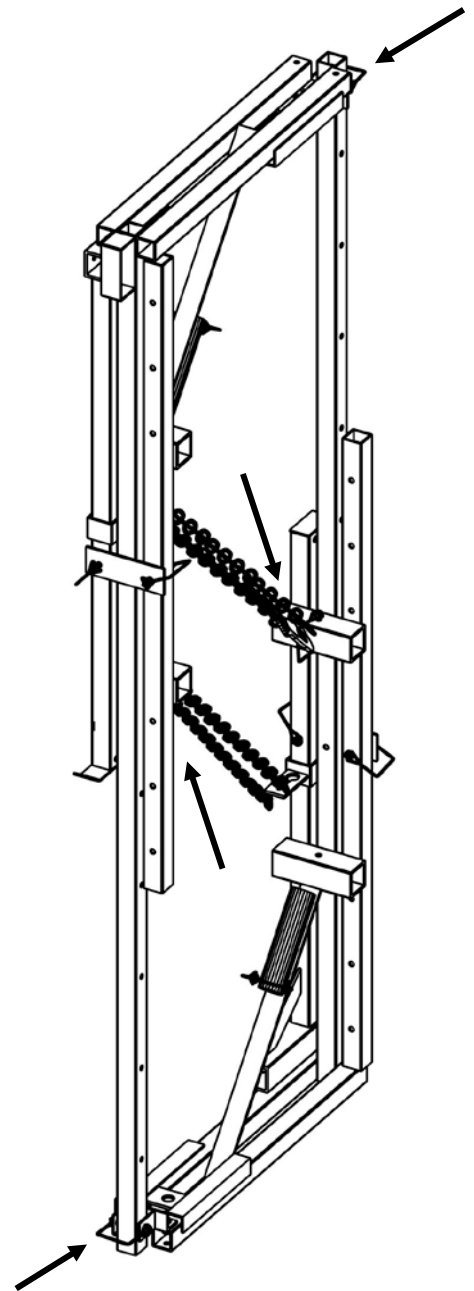

WARNING

- The frame may fail when load is applied if the correct pins are not used.
- A falling load can seriously injure or kill.
- Use only the pins that were supplied with this hoist (see "Pin Info" above).
- To prevent pin loss, store the pins on the unit.
- Order replacement pins from Superchute Ltd.

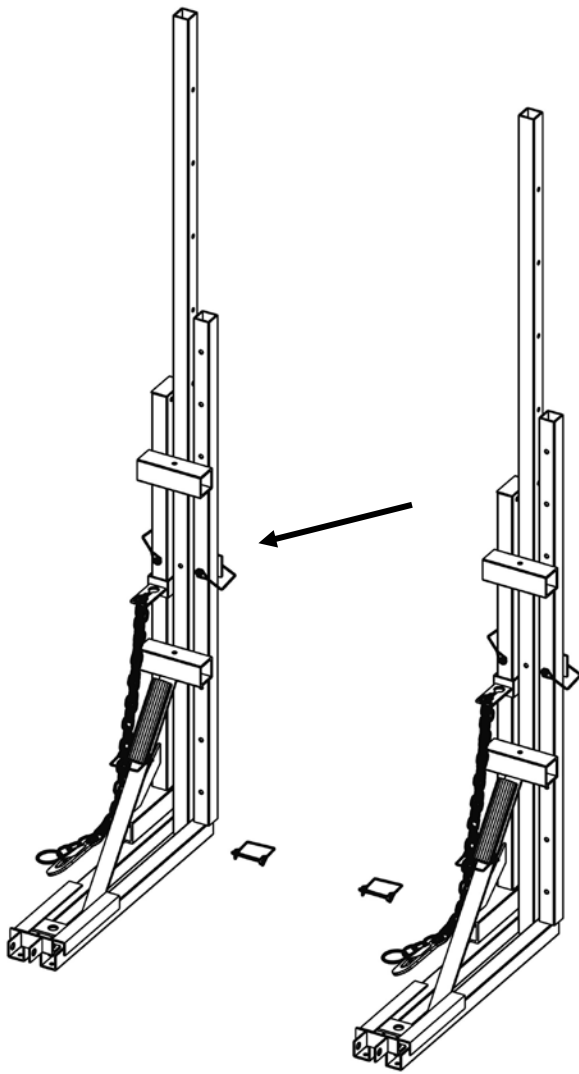

- Release the 2 Tie Bars.

- Install the Tie Bars.
- Secure with 4 pins.

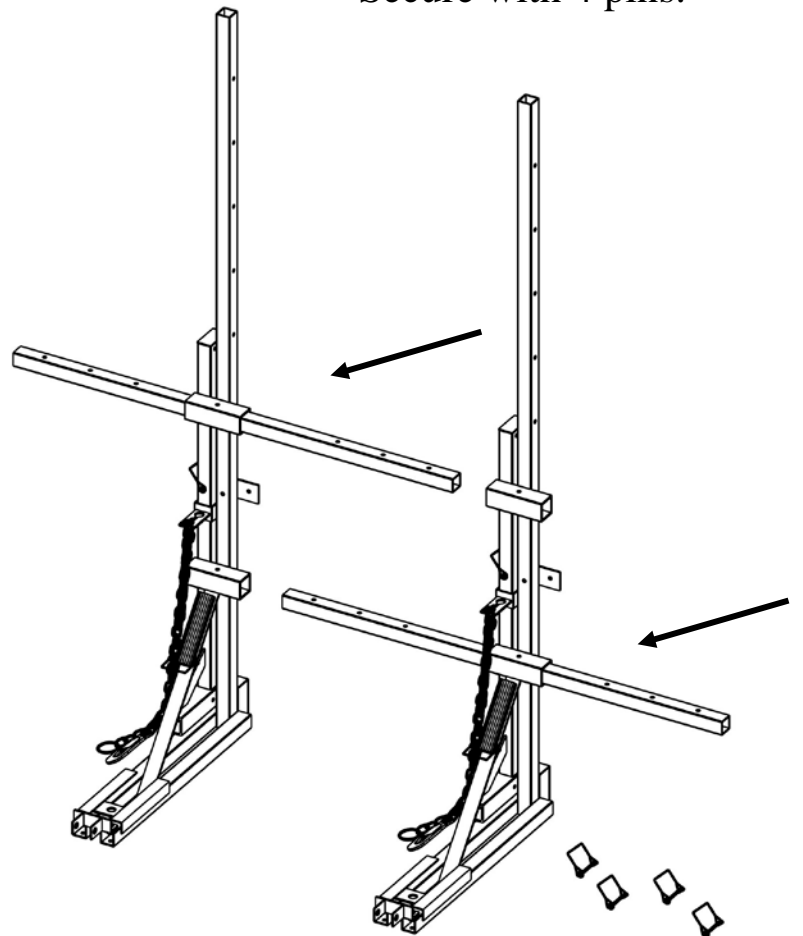

- Release the Booms from their storage slots.
- Place the Booms on the concrete floor slab.
- **To prevent the unsecured hoist frame from toppling over, DO NOT install the Booms at this time.**

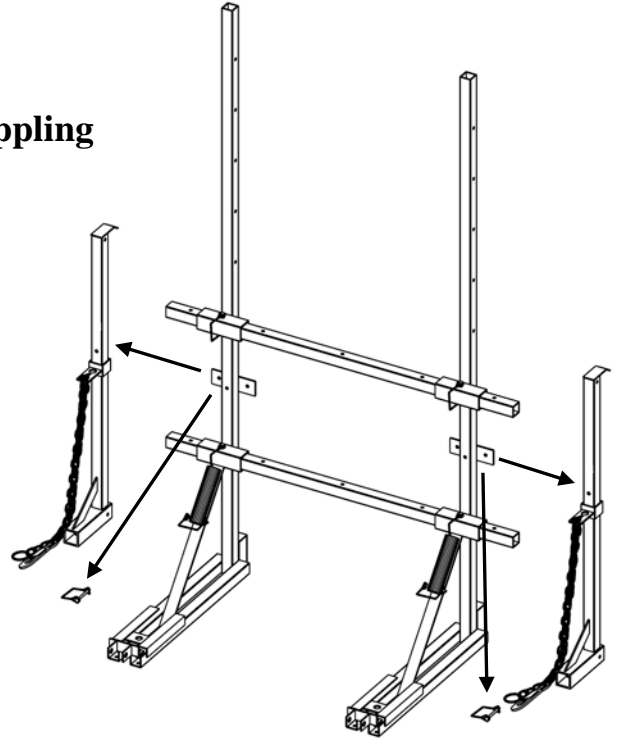

- Position the hoist frame where you wish to anchor it
- (if the hoist will be installed facing an unprotected edge, leave 3” between the toeboard brackets and the floor edge).

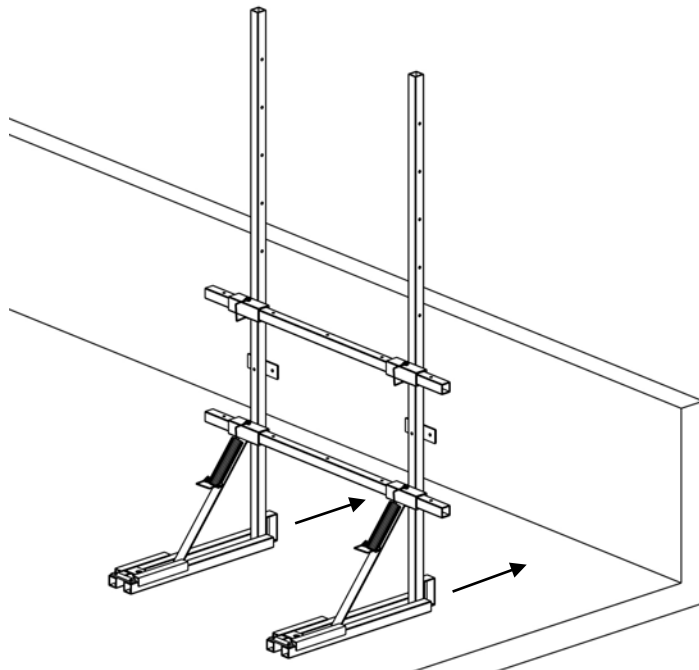

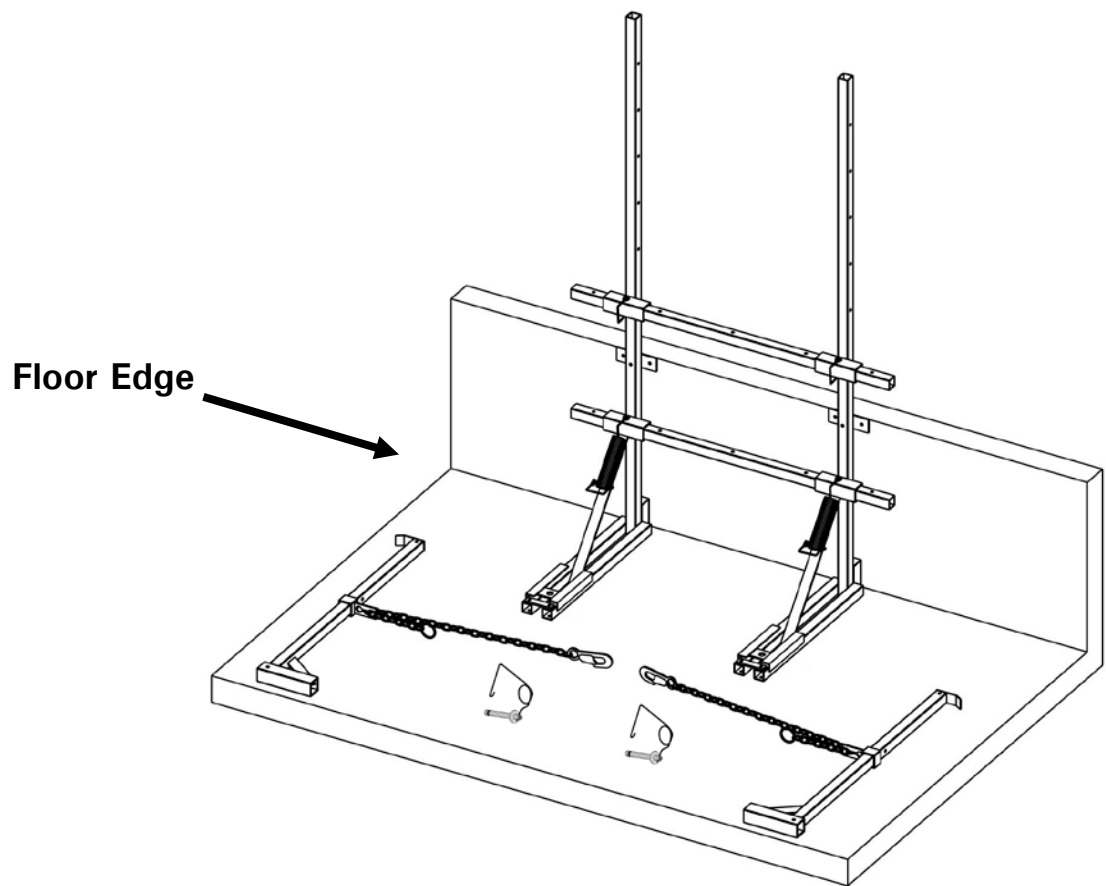

WARNING

- A person can easily fall off of a building if the floor edge they are working near does not offer fall protection safeguards.
- A fall from a height of 6 ft. is enough to seriously injure or kill.
- OSHA requires that fall prevention barriers be at least 42" high, plus or minus 3". Guardrail systems, parapet walls, and window sills may be acceptable fall prevention barriers provided they meet OSHA's height and strength criteria.
- Use a personal fall arrest system (harness and rope, or similar device) when working near a floor edge that does not offer proper fall prevention barrier(s).
- Read and understand the OSHA fall protection regulations (a few of the regulations are provided on the next page).

10. A FEW FALL PROTECTION REGULATIONS

“The employer shall determine if the walking/working surfaces on which its employees are to work have the strength and structural integrity to support employees safely. Employees shall be allowed to work on those surfaces only when the surfaces have the requisite strength and structural integrity.”

“Each employee on a walking/working surface ... with an unprotected side or edge which is 6 ft or more above a lower level shall be protected from falling by the use of guardrail systems, safety net systems, or personal fall arrest systems.”

“An unprotected side or edge means any side or edge ... where there is no wall or guardrail system at least 39” high.”

“Each employee in a hoist area shall be protected from falling 6 feet or more to lower levels by guardrail systems or personal fall arrest systems. If guardrail systems ... or portions thereof, are removed to facilitate the hoisting operation ... and an employee must lean through the access opening or out over the edge of the access opening (to receive or guide equipment and materials, for example) that employee shall be protected from fall hazards by a personal fall arrest system.”

From OSHA Part 1926 Safety and Health Regulations for Construction, Subpart M, Fall Protection.

When properly used, the SC-500-bd Bolt-Down Frame Chute Hoist meets the applicable requirements of OSHA Part 1926, Subpart M, Fall Protection.

For a more complete understanding of the OSHA Regulations you can:

- Consult OSHA’s excellent online documentation on the internet: www.osha.gov.
- Telephone the OSHA bookstore (206) 553-4270 and order the OSHA Regulations on CD-ROM (price \$53).
- Telephone the OSHA bookstore (206) 553-4270 and order **29 CFR Part 1926** in print (price \$30).
- Some states have their own regulations, which will differ from the U.S. Dept. of Labor’s OSHA regulations.

11. SECURE THE FRAME

There are two ways to secure the frame:

- With two expansion anchor bolts

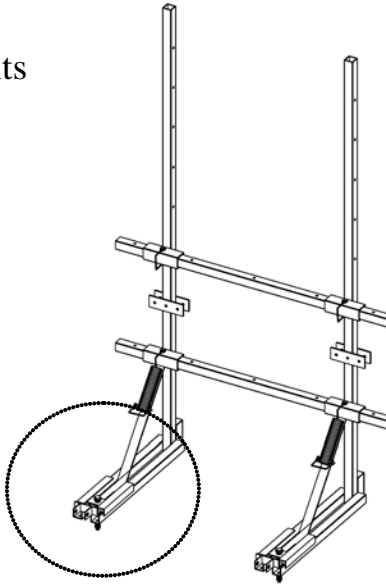

- With twelve counterweights

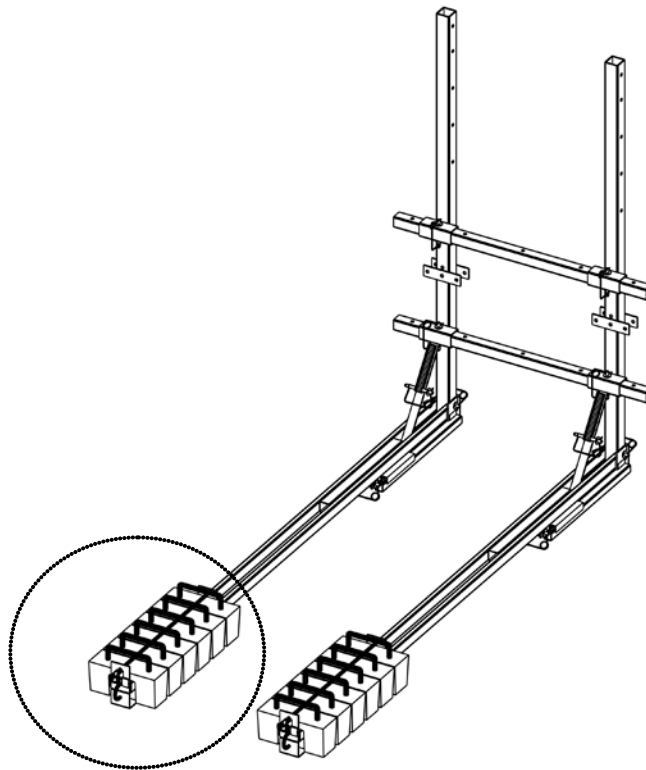

If securing the frame with counterweights, please proceed to [Section 14](#).

B) DRILL THE HOLES

1. Slide the anchor plates away from the diagonal mast braces.
2. While wearing eye protection, drill 2 holes into the concrete. Use the hole in each anchor plate as a template.
3. Drill the holes to the appropriate depth (consult chart on previous page) using the correct drill bit diameter.
4. To prevent damage to the underside of the floor, avoid drilling right through the slab.
5. Use a blow-out bulb or compressed air to clean the dust from the holes.

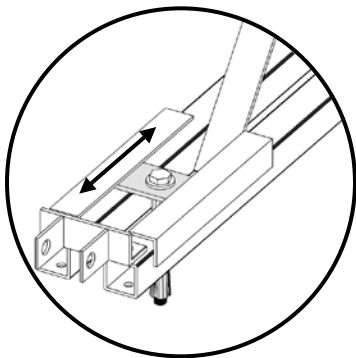

1

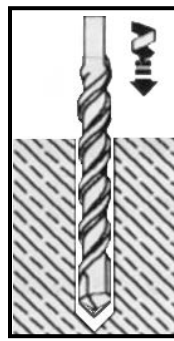

2, 3, 4

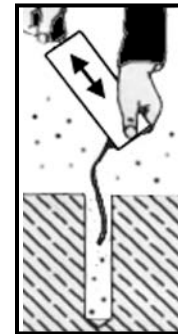

5



WARNING

- Concrete floors can contain embedded cables that are under tension.
- Drilling a hole in such a floor could cut through an embedded cable.
- A severed cable could shoot out of the slab like a missile, and could seriously injure or kill.
- Before drilling holes into the floor, ask a structural engineer to verify the adequacy of the concrete floor slab.

C) HOLE ALIGNMENT

- It is possible that 2 suitable holes will not be aligned. The frame features sliding anchor plates to account for this possibility. For example: the worker may encounter embedded steel reinforcement bar.
- Although a hole can be drilled at any point offered by the sliding anchor plate, it is best to drill it at the position that is the furthest from the masts.

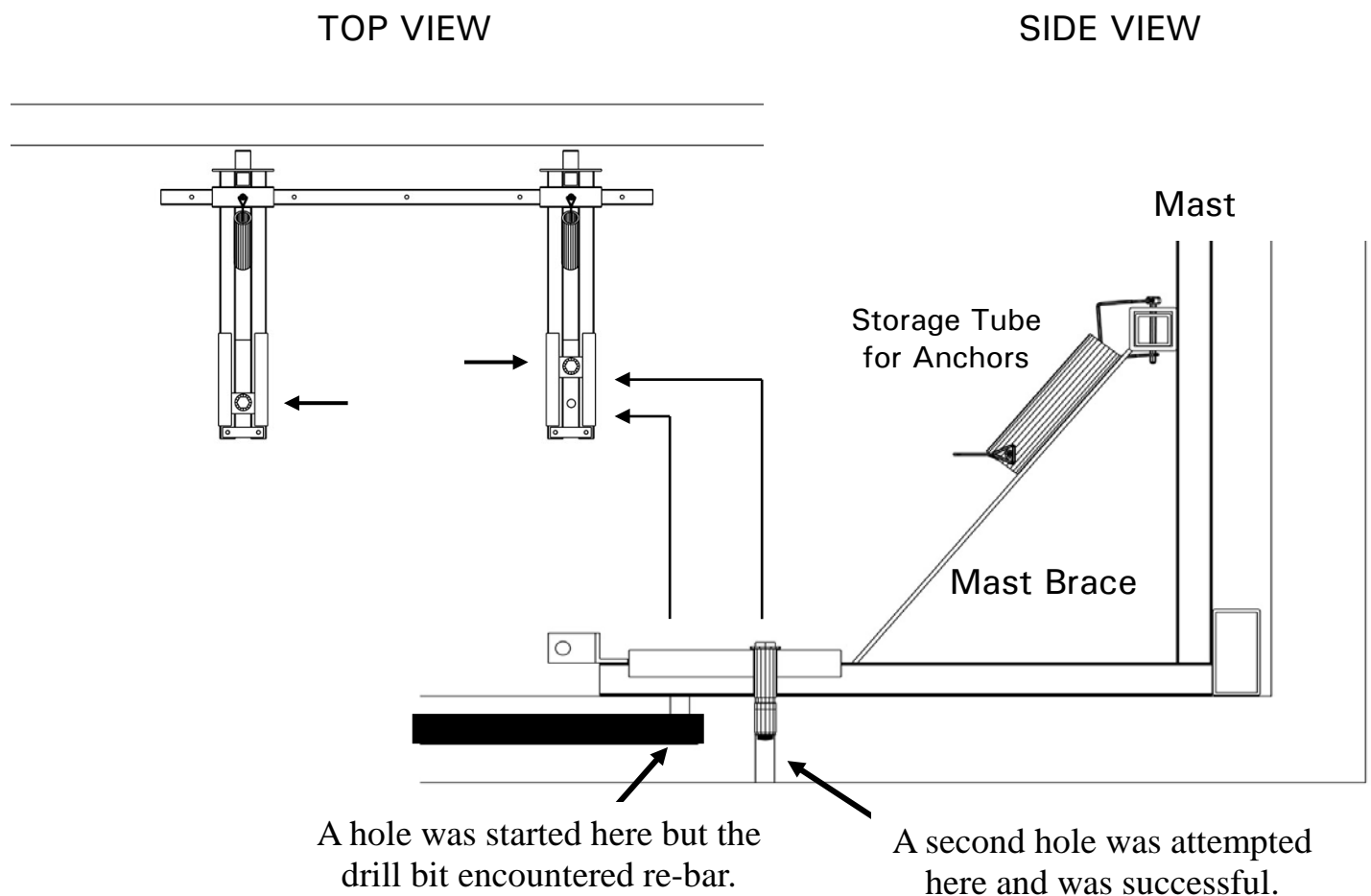

13. ANCHOR THE FRAME TO THE CONCRETE SLAB

1. Insert an approved model of anchor bolt through each anchor plate and into the prepared holes. The anchor plates may, or may not, be in alignment.
2. Gently hammer the anchor bolts until the bolt heads & washers are firmly seated against the anchor plates. Do not expand the anchor bolts by hand before tapping them into the hole.
3. Tighten the anchor bolts with a torque wrench.¹ A torque wrench will allow you to ensure that the bolts are properly tightened. Torque wrenches are available for purchase from Superchute Ltd.
4. Use this chart to determine the required tightening torque.

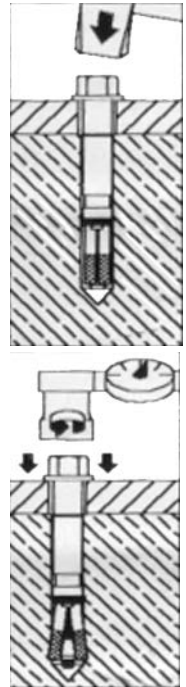

Scale	Brand of Bolt	Model No.	Wrench Size	Max. Torque
Metric →	HILTI® Bolt	HSLB M12/50	24 mm socket	60 ft. lb. ¹
Metric →	HILTI® Bolt	HSL M12/50	19 mm socket	60 ft. lb.
Imperial →	Power-Bolt™	6945	¾” socket	See note below ²

¹ Model HSLB M12/50 does not require the use of a torque wrench. When the required tightening torque is applied, the red indicator cap shears off.

² If installing the Power-Bolt™ in NORMAL WEIGHT CONCRETE use a guide torque of 100 ft. lb. If installing the Power-Bolt™ in STRUCTURAL LIGHTWEIGHT CONCRETE use a guide torque of 60 ft. lb. Where the concrete type, material strength or condition is unknown or questionable, job site tests are needed.

WARNING

- The frame may pullout when load is applied if an approved model of anchor bolt is not used.
- A falling load can seriously injure or kill.
- Use only an approved model of anchor bolt. The three anchor bolt models listed above are the only approved models.
- Replacement anchor bolts can be ordered from Superchute Ltd.

Armstrong® Torque Wrench:

- Made in the USA
- Model No. 64-407
- Large Dial provides readings in Foot Pounds & Newton Meters
- Drop Forged ½” drive
- Has ratchet head
- Has memory needle
- Includes protective case
- Lifetime Guarantee

*Available for purchase
from Superchute Ltd.*

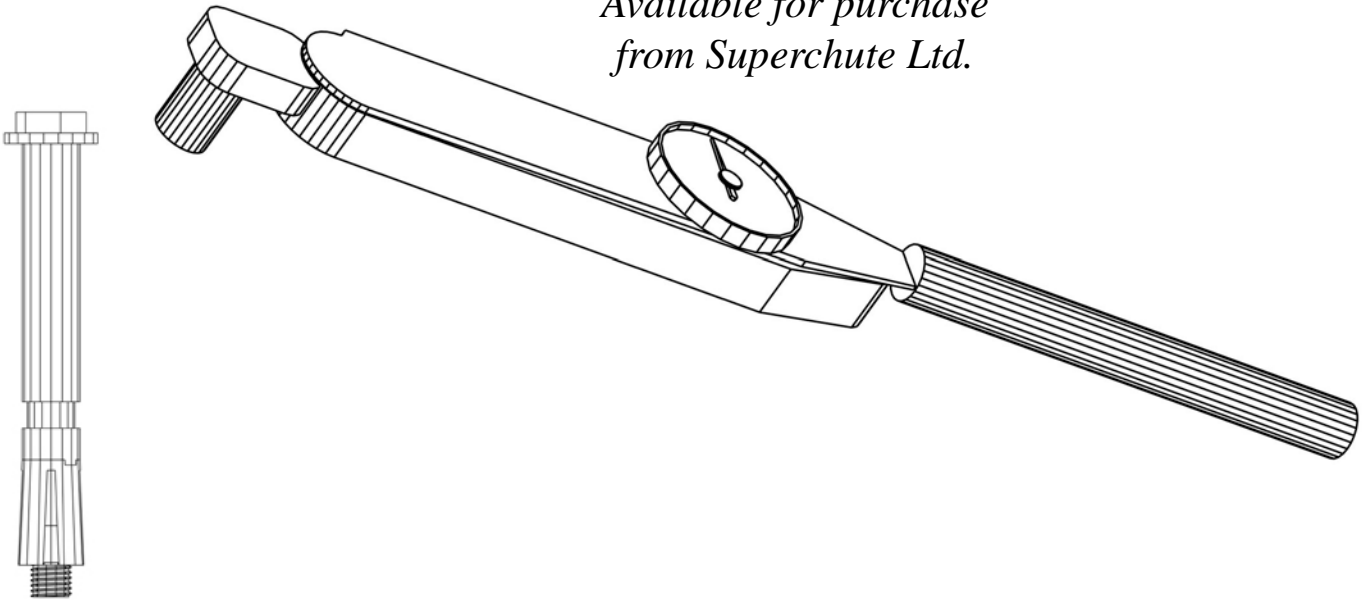

The expansion bolts are not reusable,
except in the original hole.
Order spares from Superchute Ltd.

14. THE COUNTERWEIGHT KIT

In cases where the floor cannot accommodate Expansion Anchors, the Frame may be secured using a Counterweight Kit. The Kit is installed as shown:

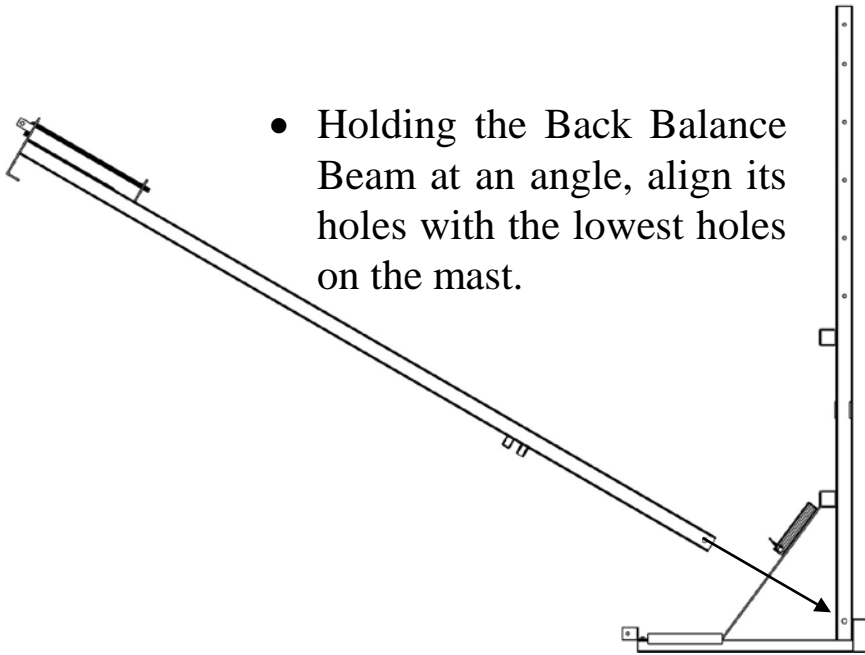

- Holding the Back Balance Beam at an angle, align its holes with the lowest holes on the mast.

A close-up technical drawing of a hole in a pipe. The hole is labeled "Centered" and "9/16" Diameter". A vertical dimension line indicates the hole's center is "2 1/4" above the base of the pipe.

If the masts do not have a hole near the toeboard bracket:

- Drill a 9/16" diameter hole in the center of the main vertical pipe, per the sketch above.
- The hole's center should be 2 1/4" above the Mast base.

All hoists can be sent to the Superchute® Factory for upgrades.

- Insert the supplied pin while keeping the tail of the Back Balance Beam raised off the ground.
- Repeat with other Mast.

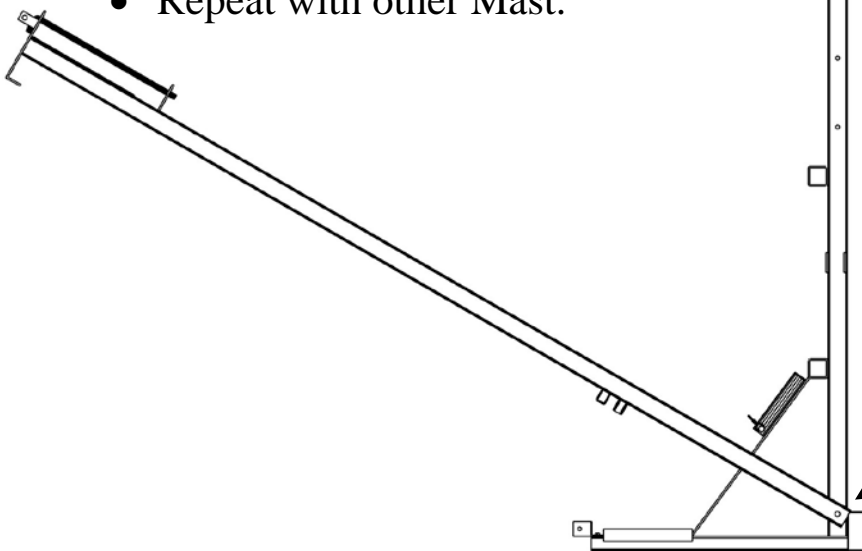

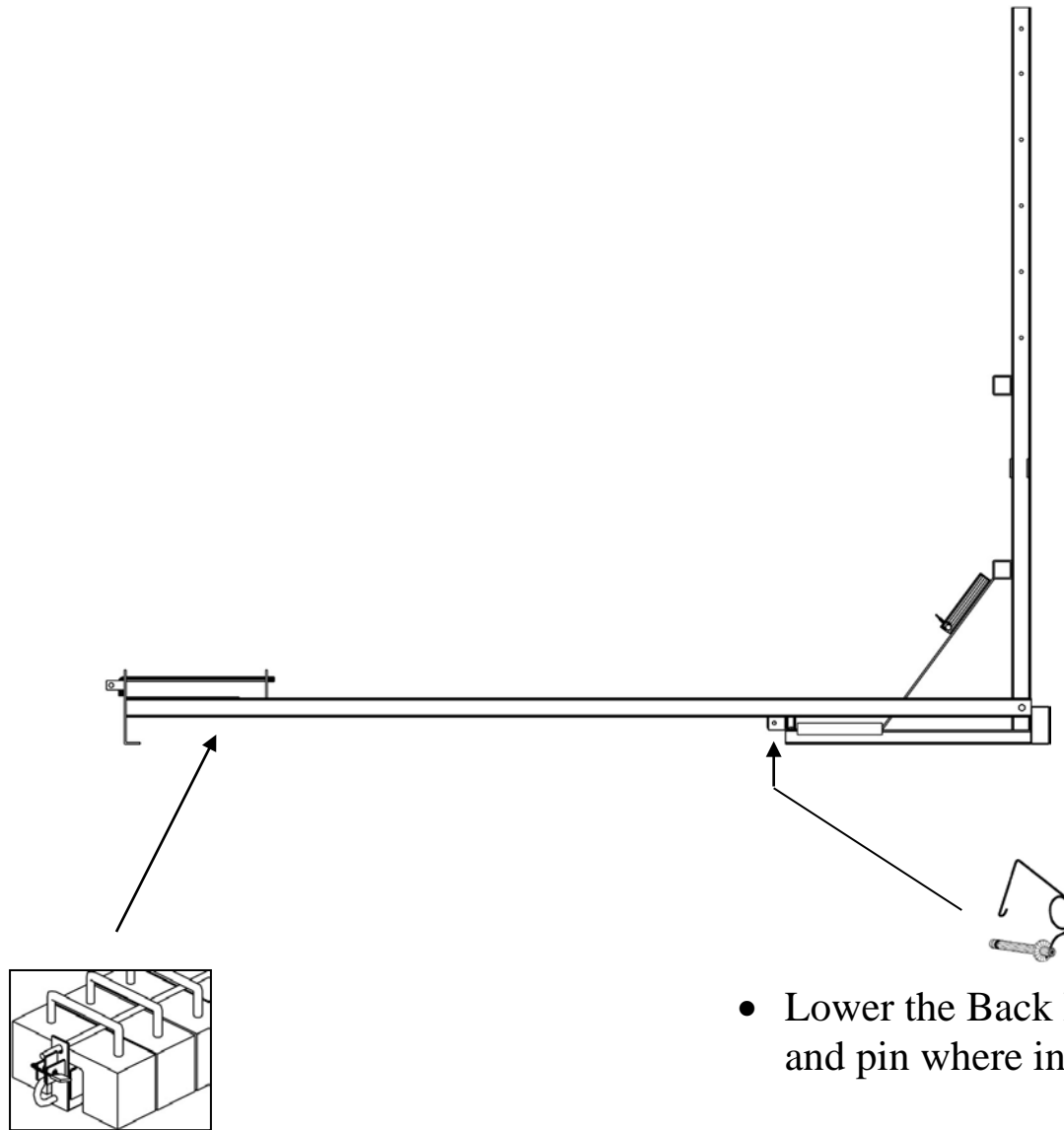

- Lower the Back Balance Beam and pin where indicated.

- Lower a weight into the weight carriage and slide it back. Repeat.
- Place 6 counterweights in each weight carriage.
- In total there should be 12 cast iron weights (55 lb. each) on the hoist.
- Always install all of the weights.
- Pass the weight retaining rods through the weight handgrips.
- Use the 2 supplied padlocks to lock the retaining rods and prevent weight removal.

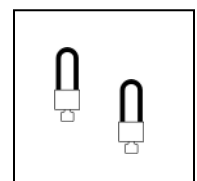

- If the hoist frame was secured using counterweights, then it should be tied-back to the building to prevent it from being dragged or pulled off the building in the event of a blockage.
- Tie-back each weight beam to a structural member of the building using 5/8" nylon or 5/16" wire rope. Use the tie-back loops on the Weight Beams.
- Affix these two tie-backs to suitable structural members of the building (portions of the building structure, and window cleaning anchors are usually adequate, while roof vents, air conditioners, and parapets are usually not adequate). Avoid tying or running the rope over any sharp surfaces. **DO NOT** tie back to anchors that will be used concurrently by personal fall arrest systems.
- **Nylon Rope:** install snug, using recognized safety knots (eg. figure eight).
- **Wire Rope:** install snug, using proper hooks and fittings.
- **Tie Back Kits:** are available from Superchute® for quicker & safer tie-backs.

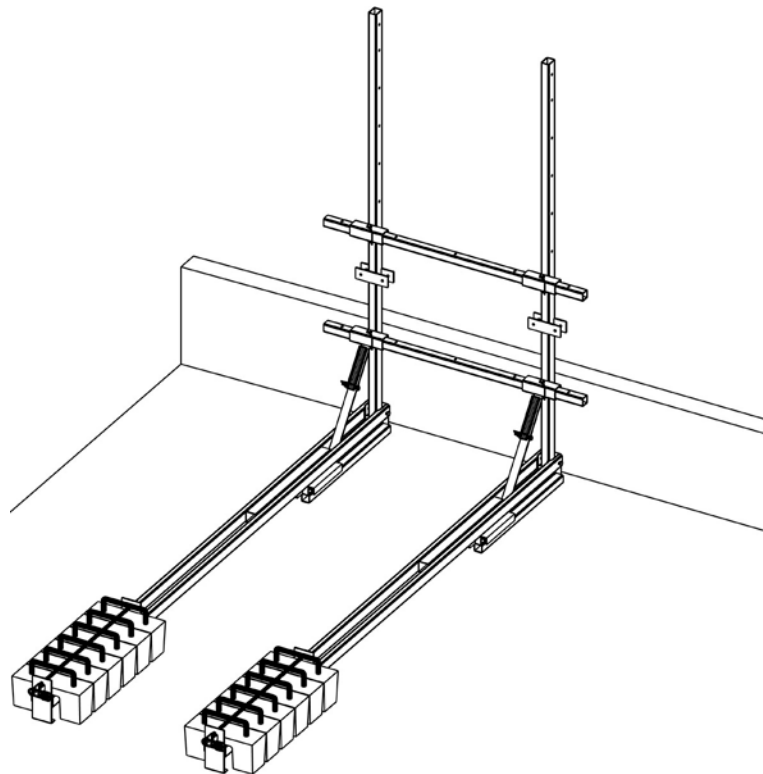

Note: The remainder of the sketches in this installation manual show the Hoist secured to the floor slab by means of expansion anchor bolts.

15. ATTACH THE BOOMS

- Install the Booms, and pin in place.
- If you will use a Fishpole to install the chutes, it is preferable to use the highest mast holes available.

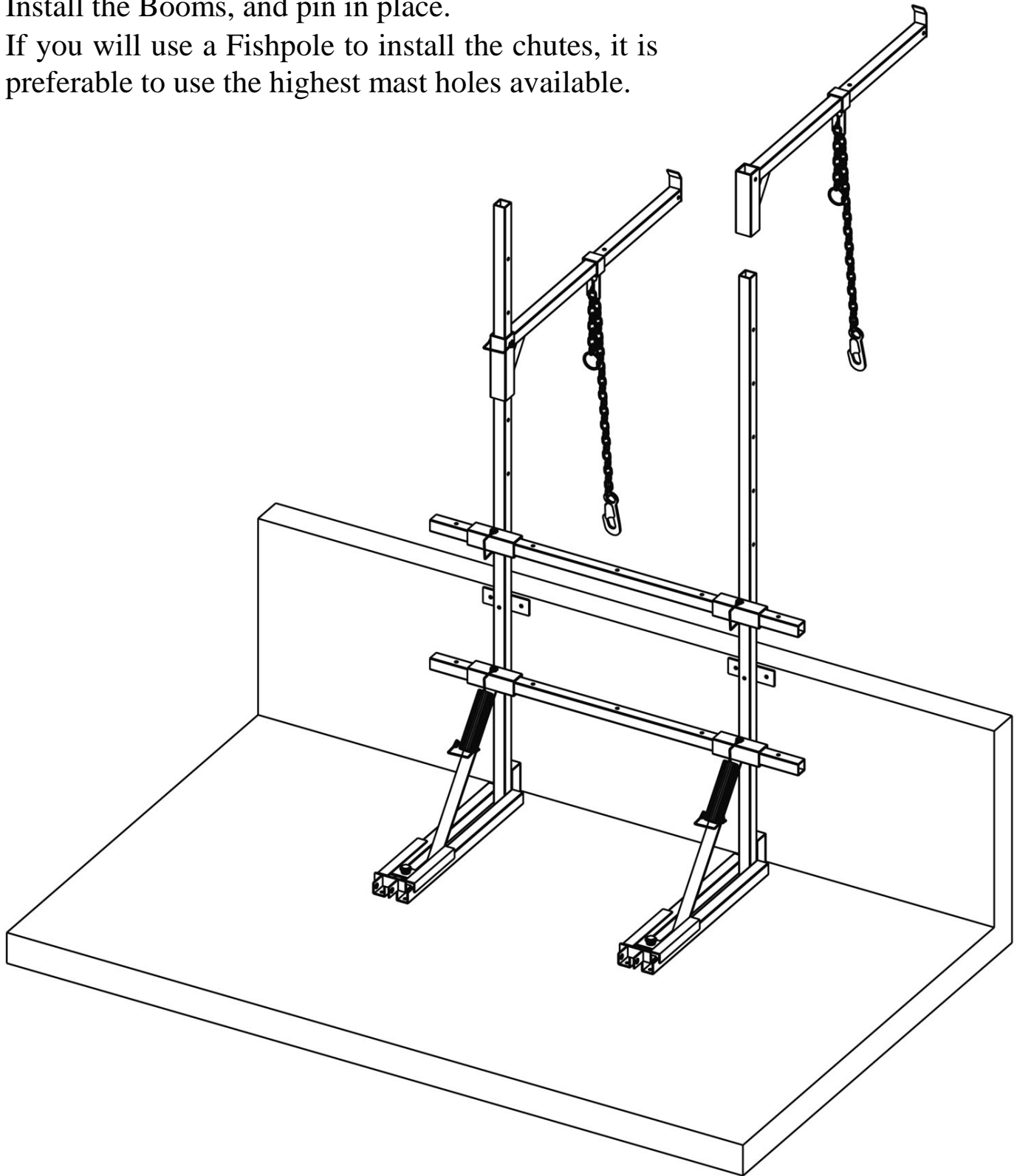

16. TOEBOARD BRACKETS

Insert a 2" x 4" wood stud through the toeboard brackets if the frame is on a floor slab without a toeboard (or equivalent, like a window sill, or parapet). This is an OSHA requirement.

The installed 2" x 4" will prevent small objects from being accidentally kicked over the edge.

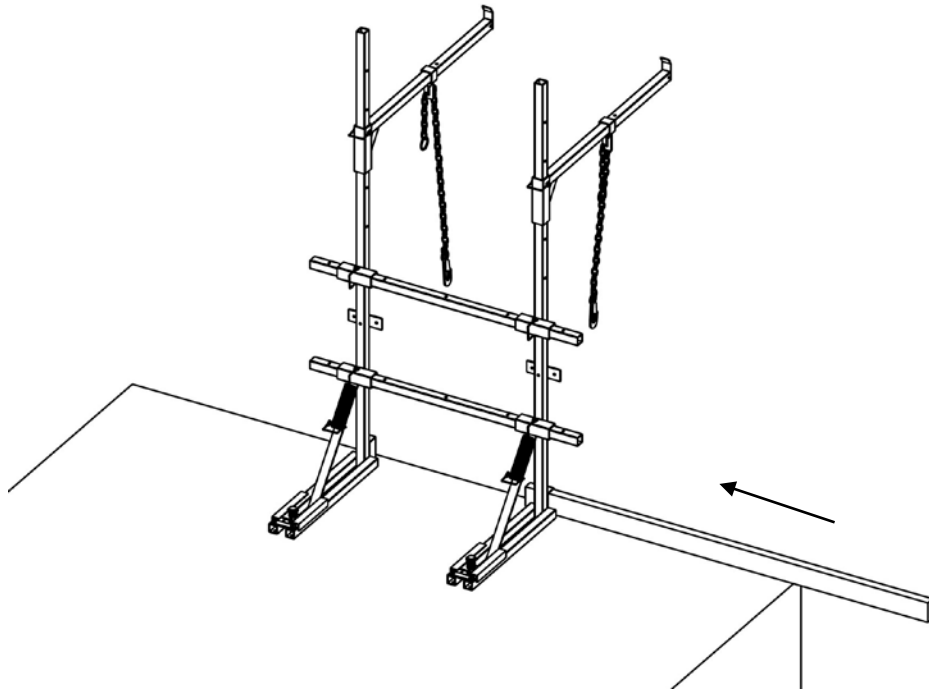

- 2" x 4" in place

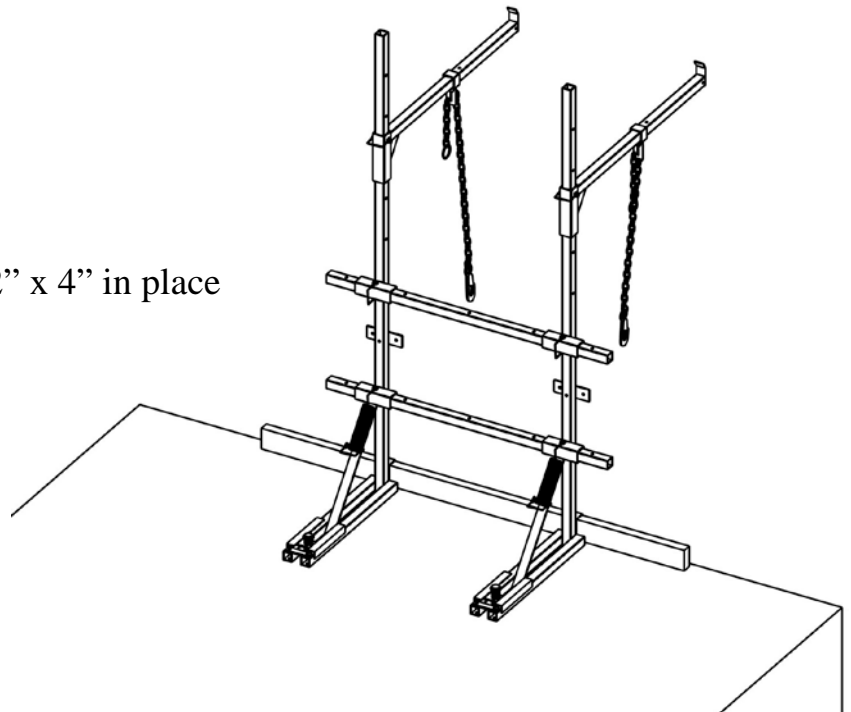

17. PREPARE & INSTALL THE FISHPOLE (IF APPLICABLE)

- ✓ *The Fishpole will be unnecessary if a crane, or similar device, will be used to lift the chute.*
- ✓ *If using a crane, or similar device, then please go directly to **Section 18**.*
- ✓ *The following instructions show the Standard Fishpole in use.*
- ✓ *If using the Tall-Job Fishpole, refer to separate instruction booklet for operation of the winch.*

- Release the Outer Cross Bar.

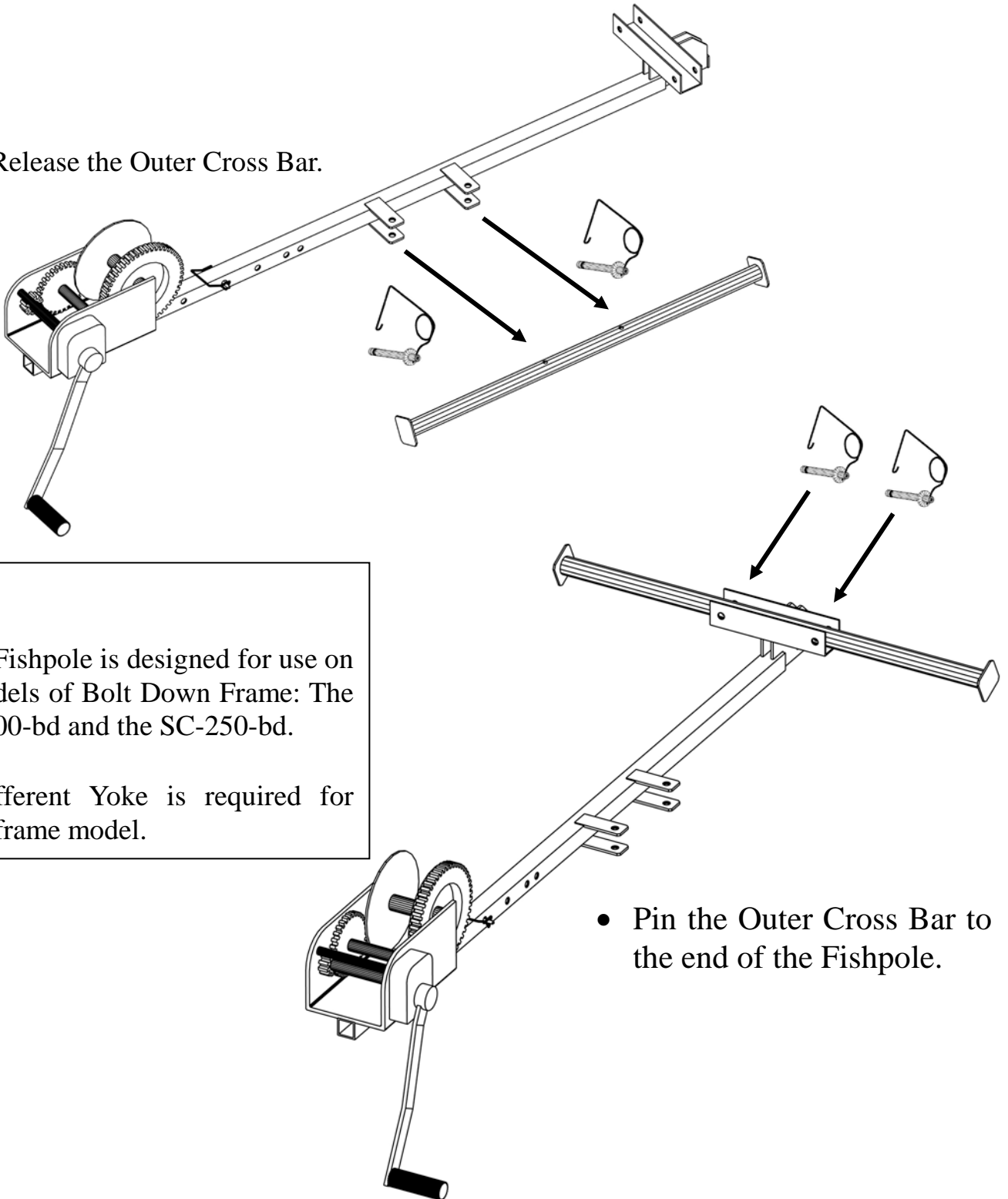

Note:

- This Fishpole is designed for use on 2 models of Bolt Down Frame: The SC-500-bd and the SC-250-bd.
- A different Yoke is required for each frame model.

- Pin the Outer Cross Bar to the end of the Fishpole.

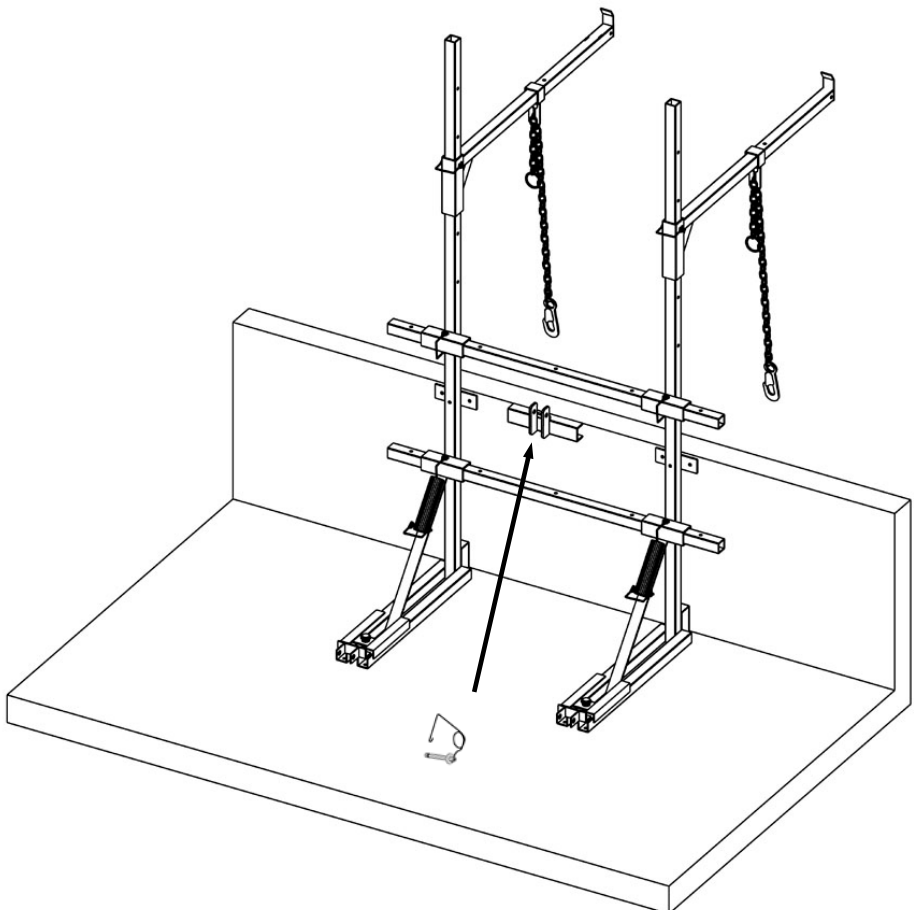

- Pin the Yoke to the upper Tiebar.

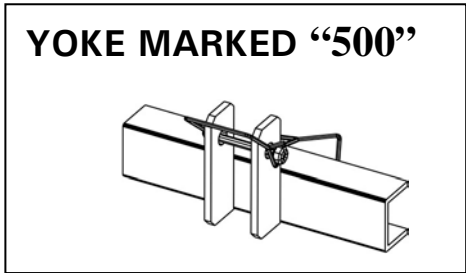

- Position the Fishpole for attachment to the Yoke.

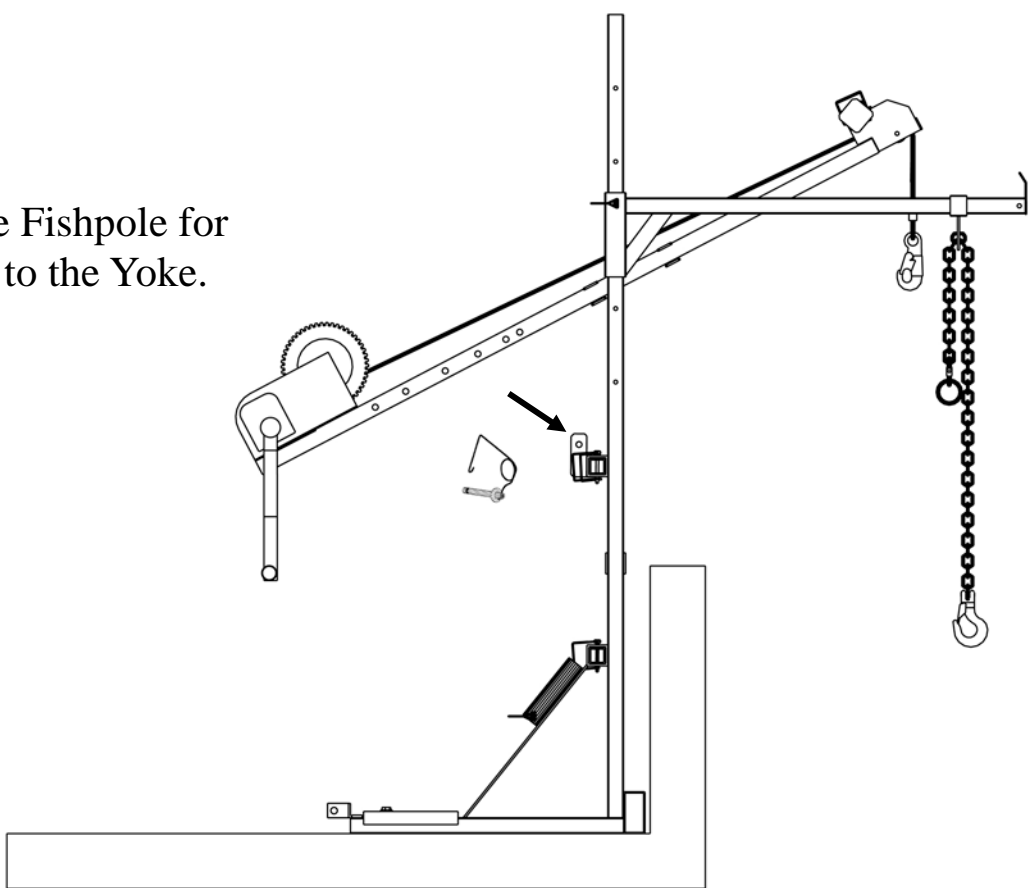

Pin the Fishpole to the Yoke

- There are five holes on the upper half of each Mast. These holes correspond to the five holes found on the Fishpole, nearest the winch.
- In the diagram below, the holes on the Masts and Fishpole are numbered 1 through 5. Hole “1” on the Mast matches hole “1” on the Fishpole, hole “2” on the Mast matches hole “2” on the Fishpole, and so on.
- For example, if the Booms are pinned to Mast hole “3” (as shown below), then the Fishpole would be attached to the Yoke using the corresponding hole “3”.
- Matching the Mast & Fishpole holes will provide the maximum amount of clearance from the building face for the chutes when they are raised.

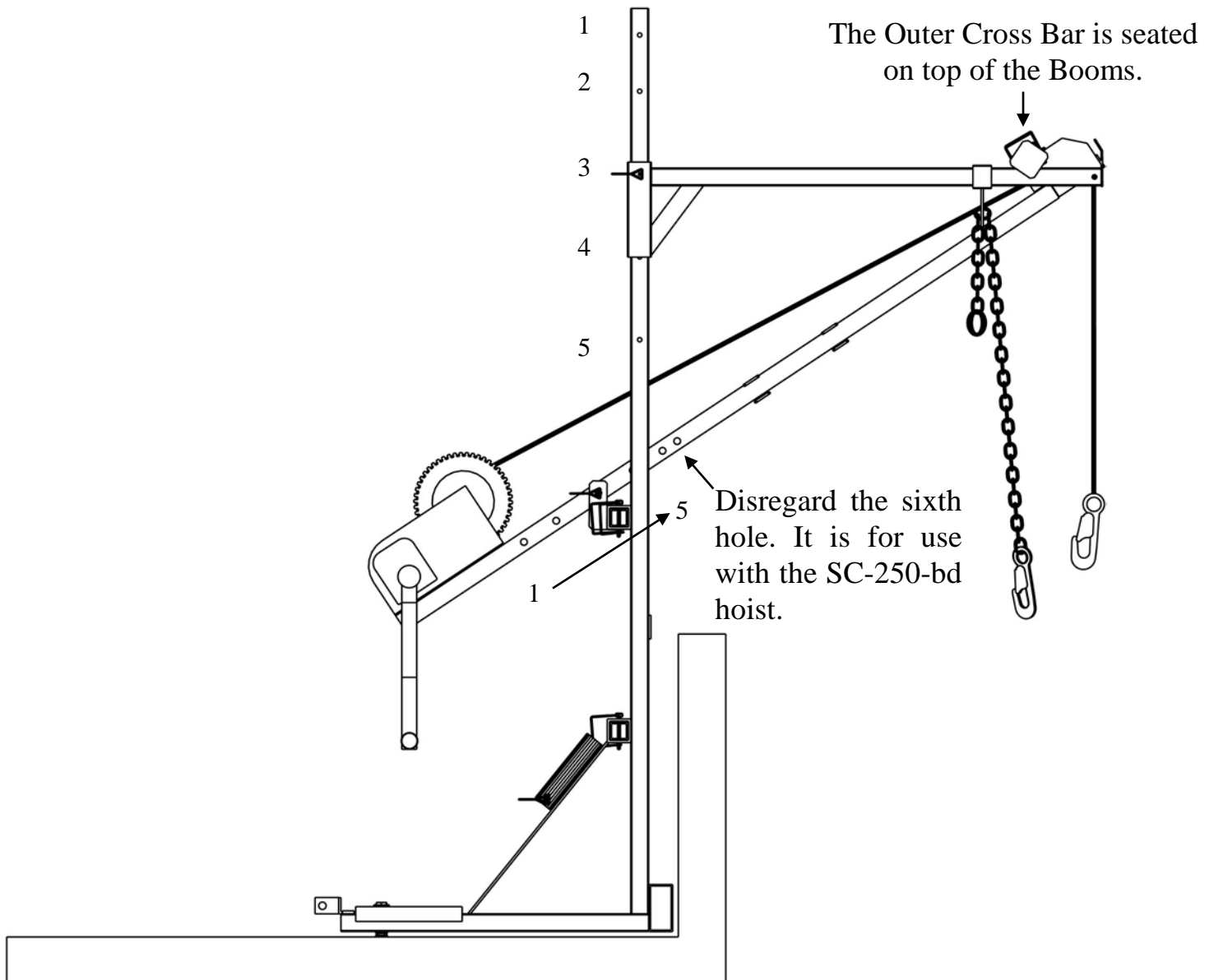

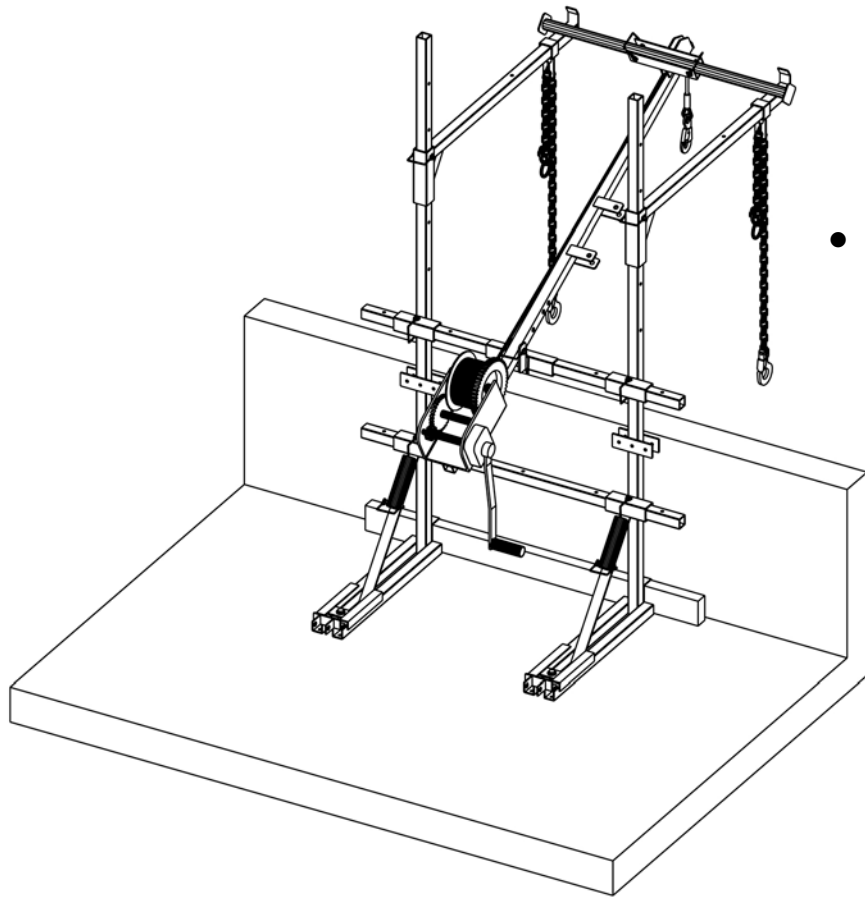

- The Fishpole is installed as shown.

- Turn the winch handle in a counter-clockwise direction to lower a few feet of cable. As the cable unspools, check it for wear and tear. If it is frayed or kinked, postpone the installation and order a new cable from Superchute Ltd.

Never substitute the cable (3/16" diameter - 7 x 19 construction) for another size or strand design.

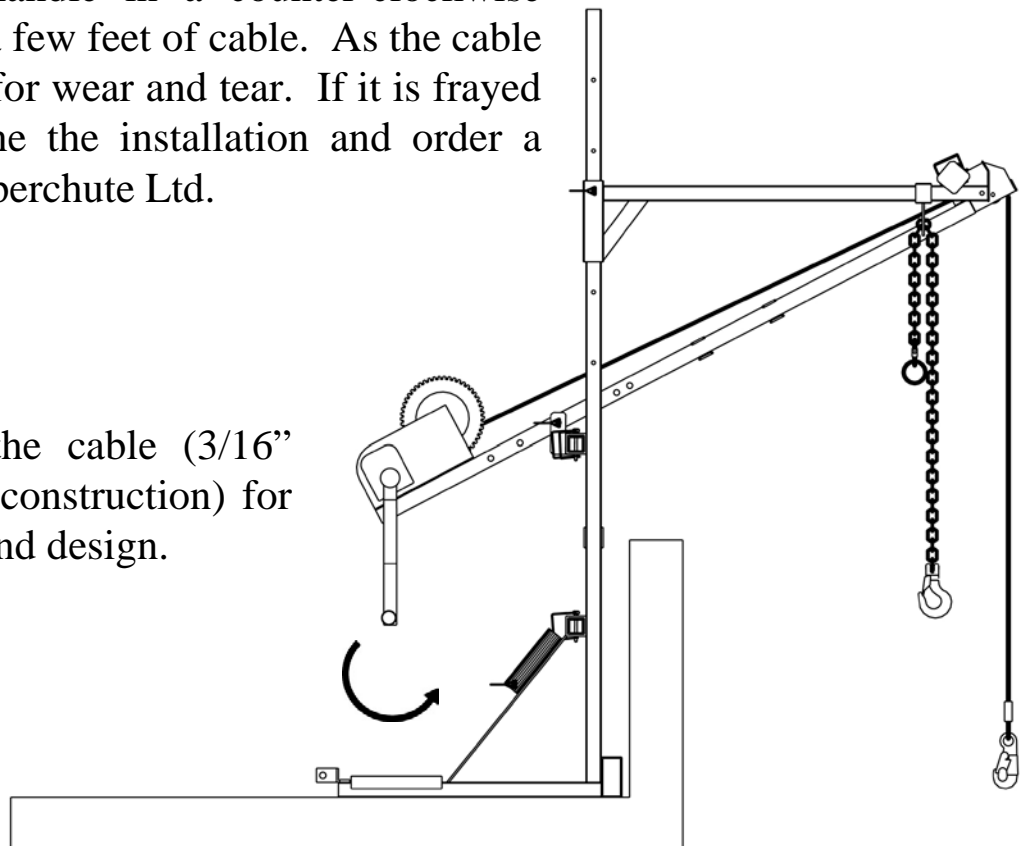

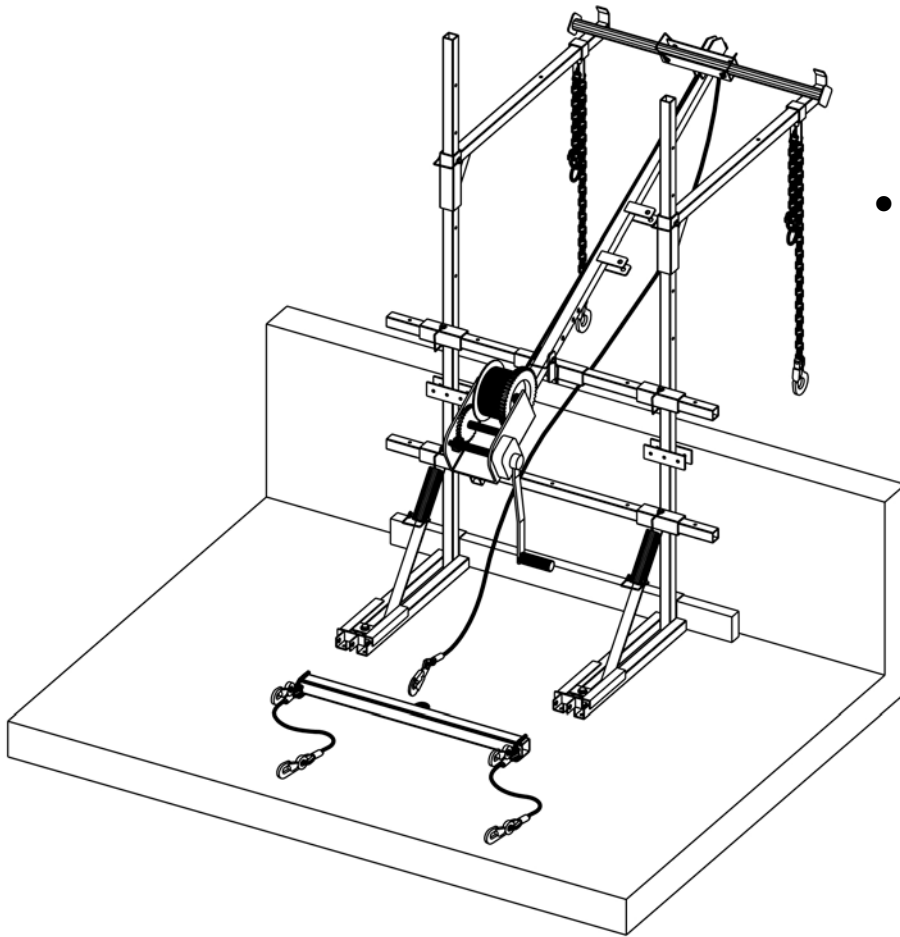

- Use a stick, pole, broom, or some other long instrument, to bring the cable onto the deck.

- Attach the cable's hook to the Spreader Bar.

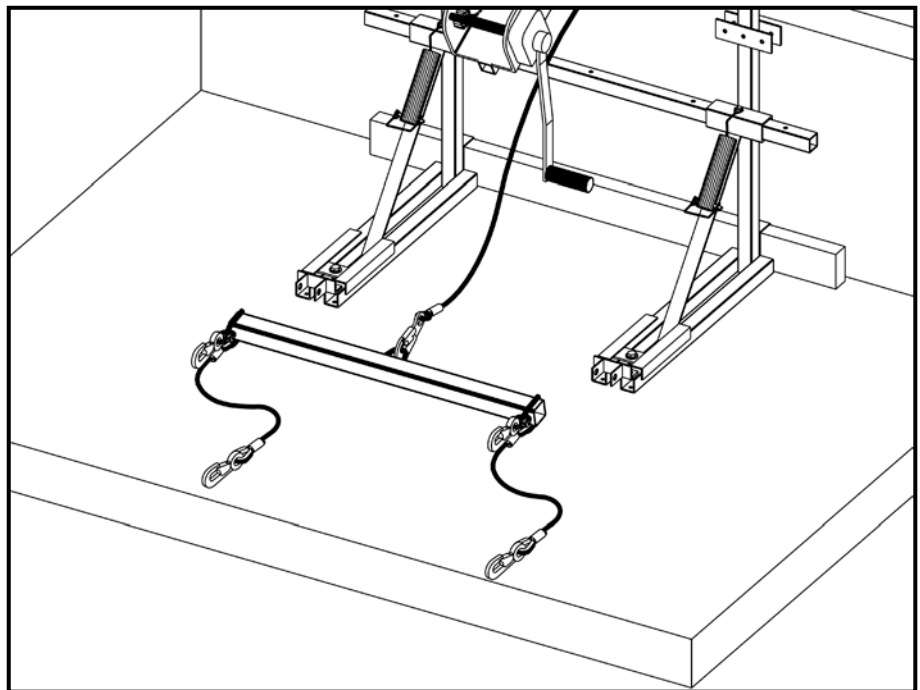

- Lower the Spreader Bar to the ground.
- Continue checking cable for wear & tear.

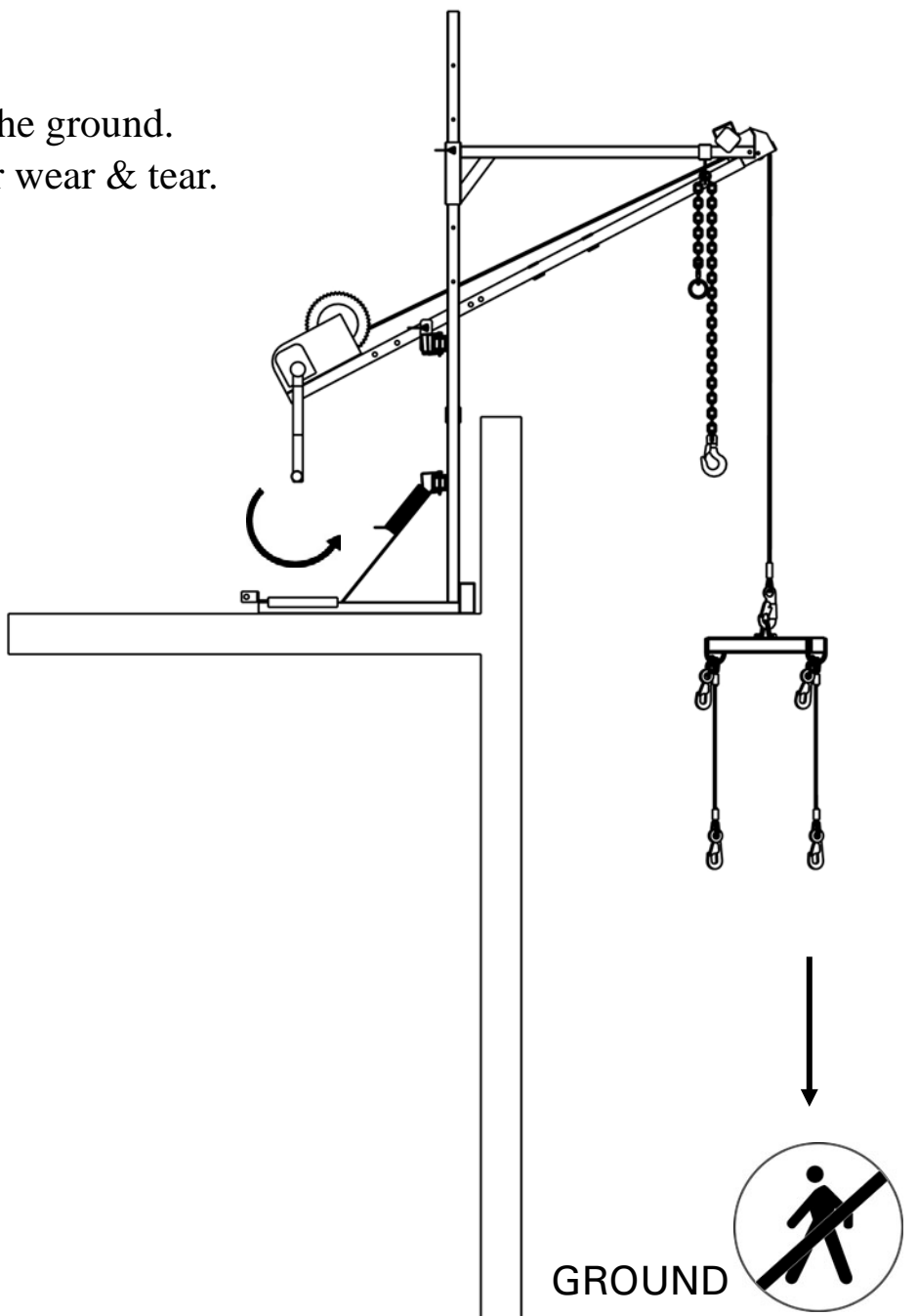

When the Spreader Bar reaches the ground you will be ready to lift.

! WARNING

- The Spreader Bar can descend quickly.
- If the descending Spreader Bar were to hit a worker or bystander it could seriously injure or kill.
- Ensure the area below the hoist is clear of workers and bystanders while the Spreader Bar is descending.

18. HOIST THE CHUTE SECTIONS INTO PLACE

Although the following sketches show the Fishpole in use, other lifting devices, such as cranes, material hoists, or boom lifts, may be appropriate as long as they can safely manage the chute load. All lifting devices require the procedure shown in this section.

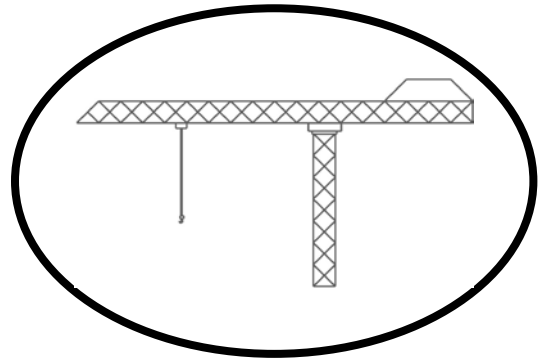

- Attach a chute section to the Spreader Bar.

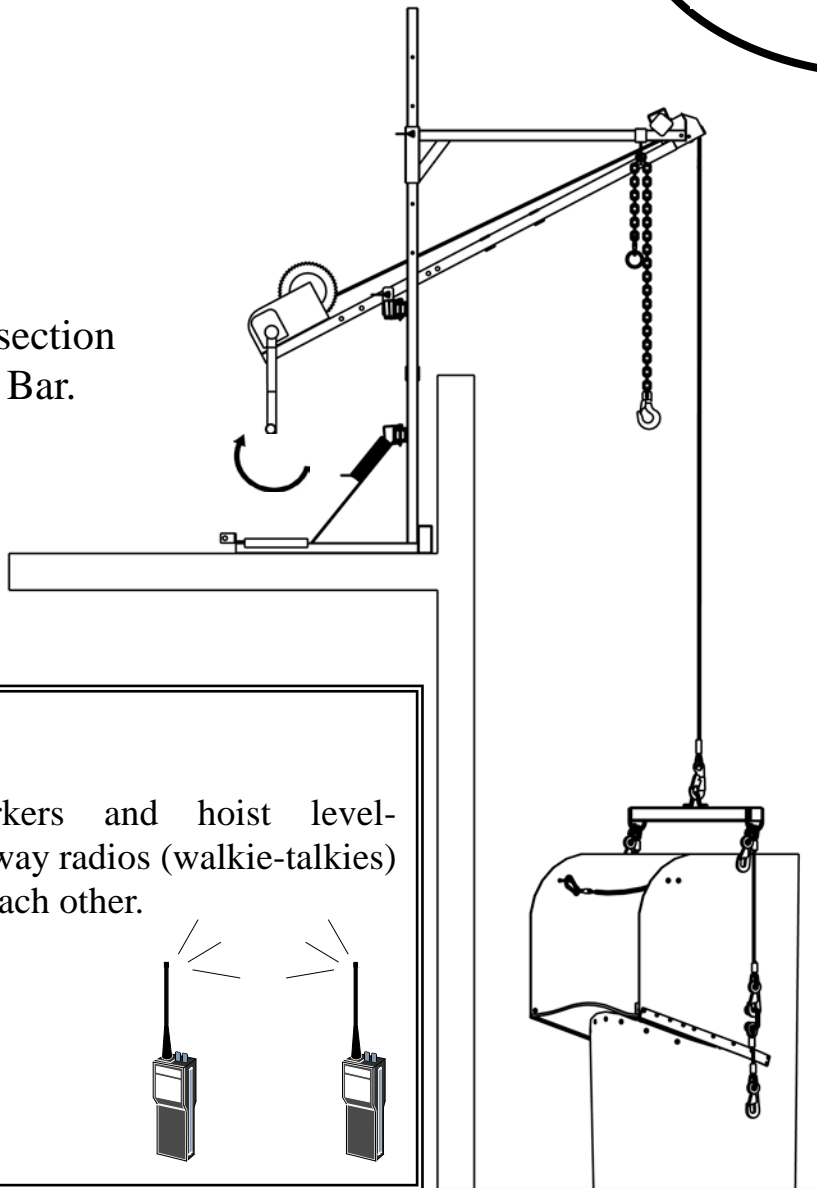

Communication:

Ground-level workers and hoist level-workers should use 2-way radios (walkie-talkies) to communicate with each other.

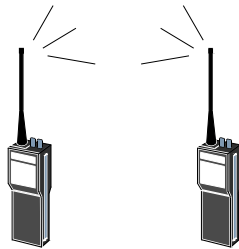

WARNING

- GROUND WORKERS MUST WEAR HARDHATS

HOIST THE CHUTE SECTIONS INTO PLACE (continued)

- Raise the section 4 feet.

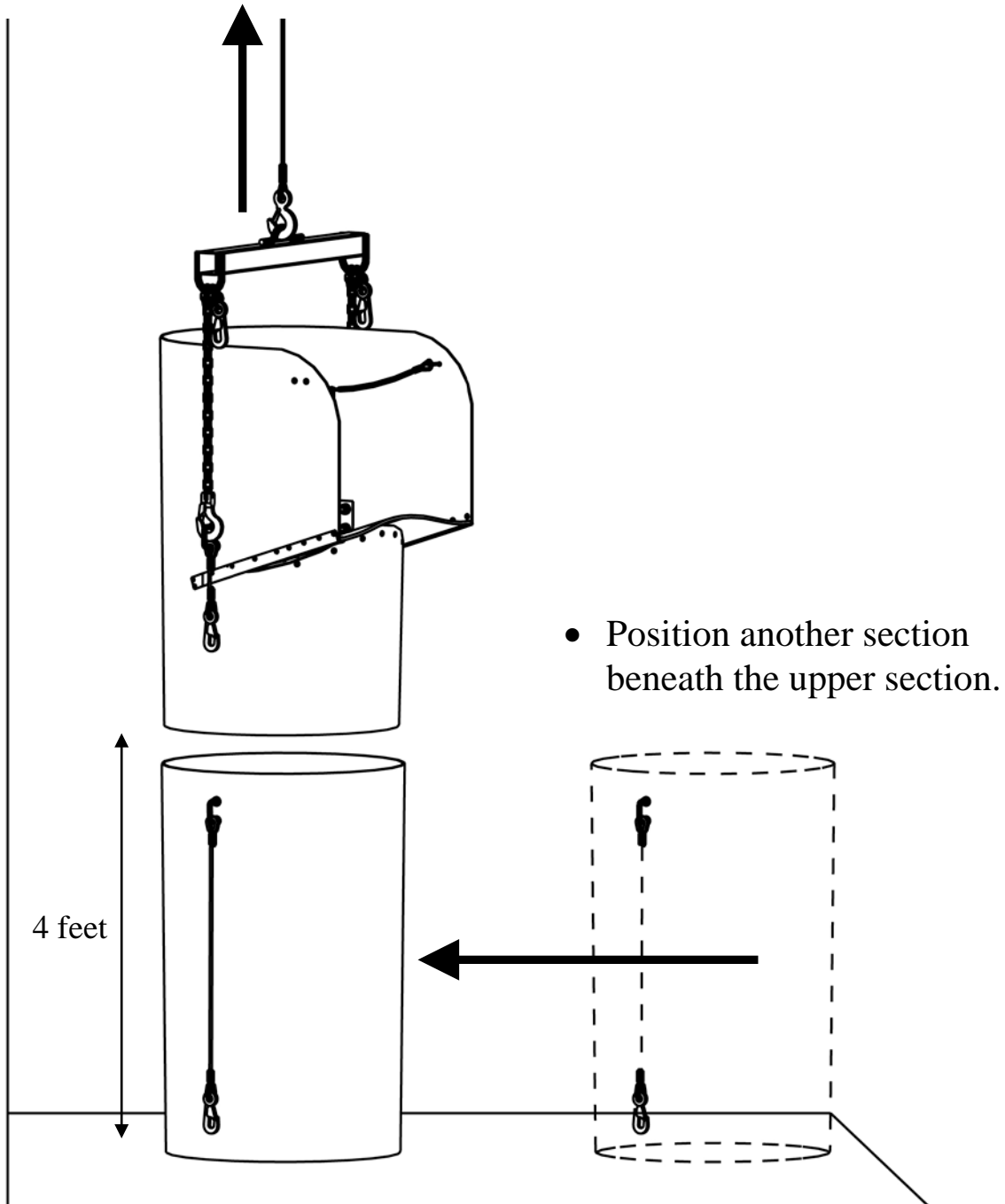

HOIST THE CHUTE SECTIONS INTO PLACE (continued)

- Lower the suspended section into the section beneath it.
- Connect the two sections with the upper section's cable assemblies.

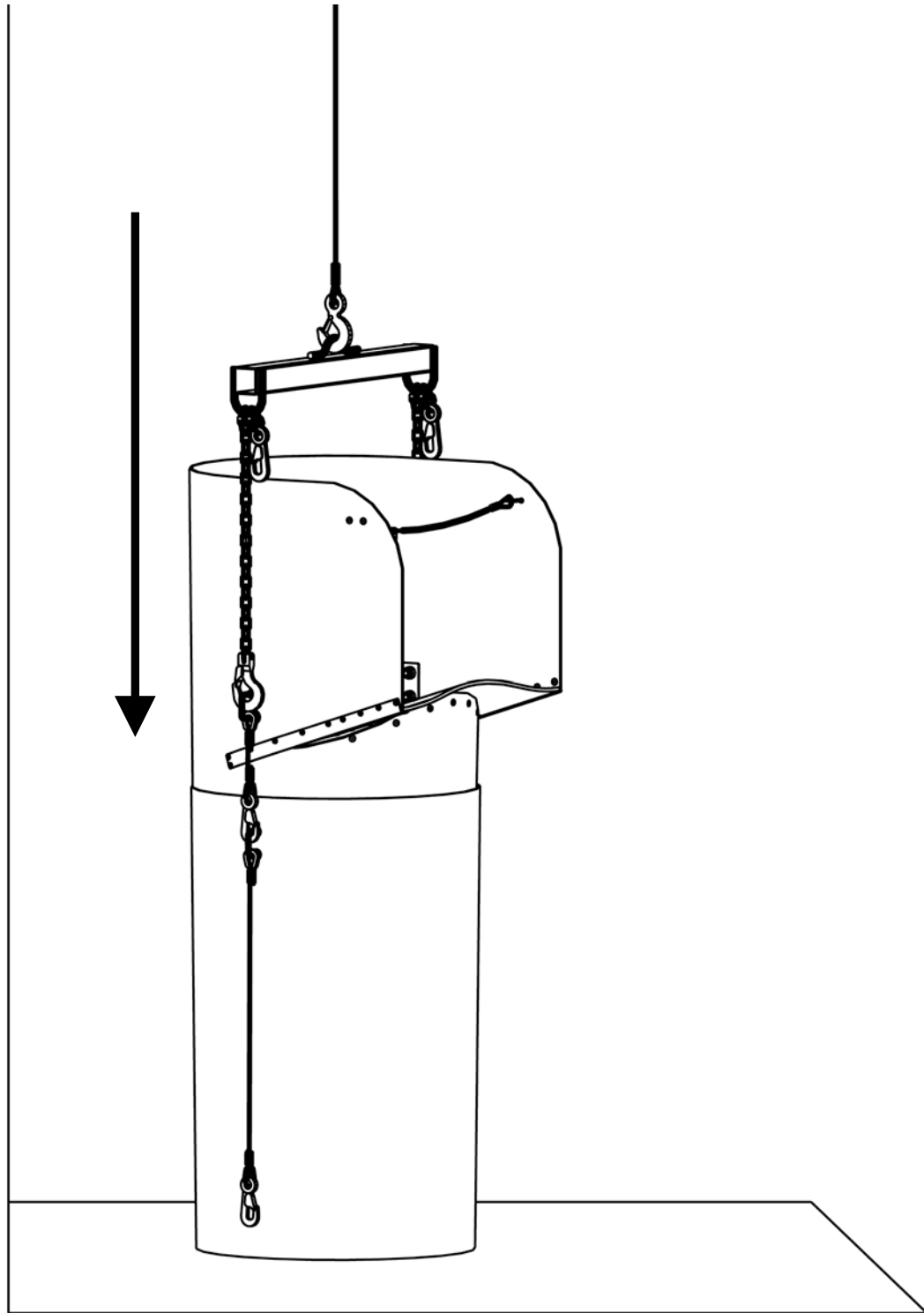

ALTERNATE THE SEAMS

As you add Regular sections, arrange them so that the **plastic weld seams** or **Wraparound® clasp seams** alternate from side to side, as depicted in the sketch below. Alternating the seams from side to side will help the chute hang straight.

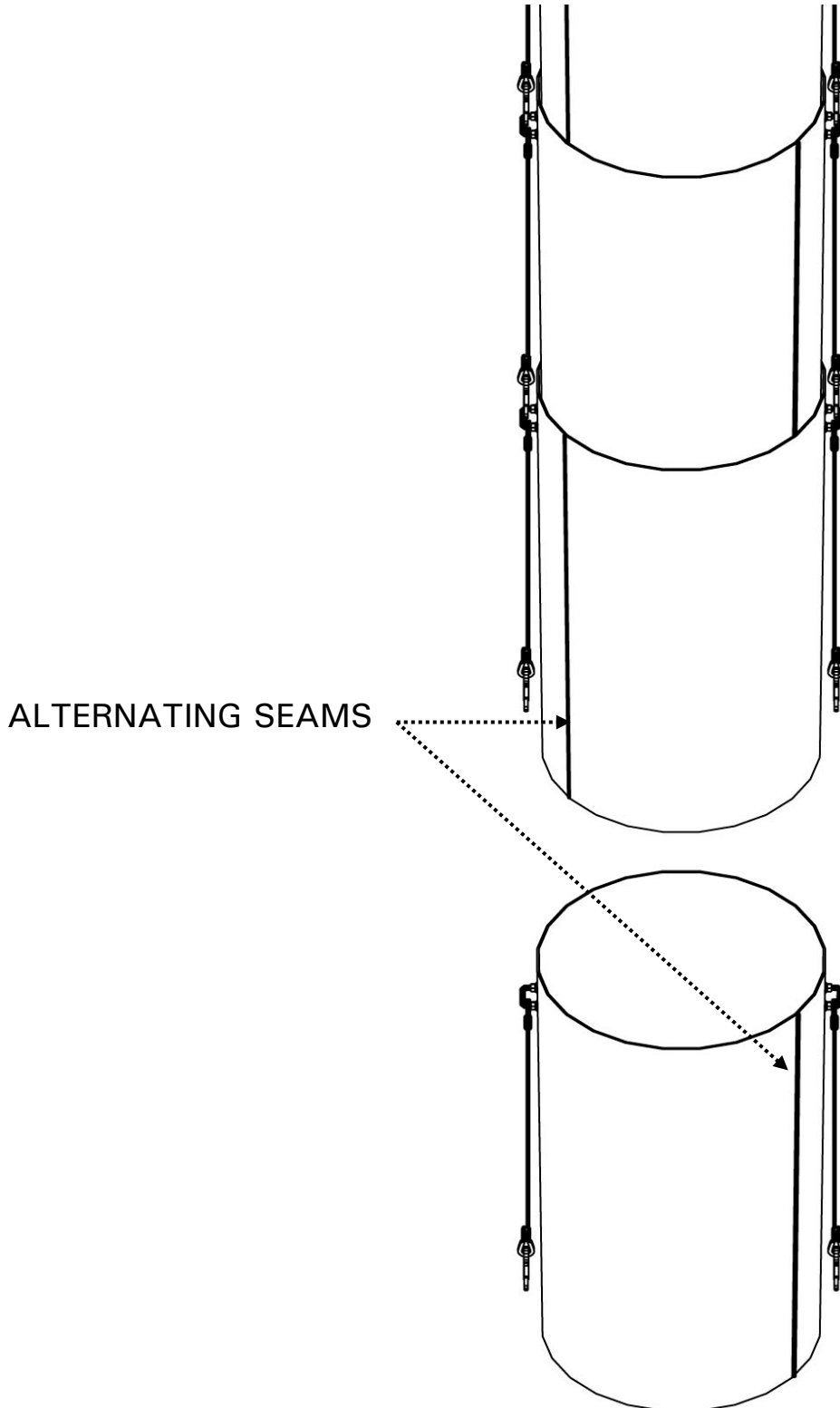

HOIST THE CHUTE SECTIONS INTO PLACE (continued)

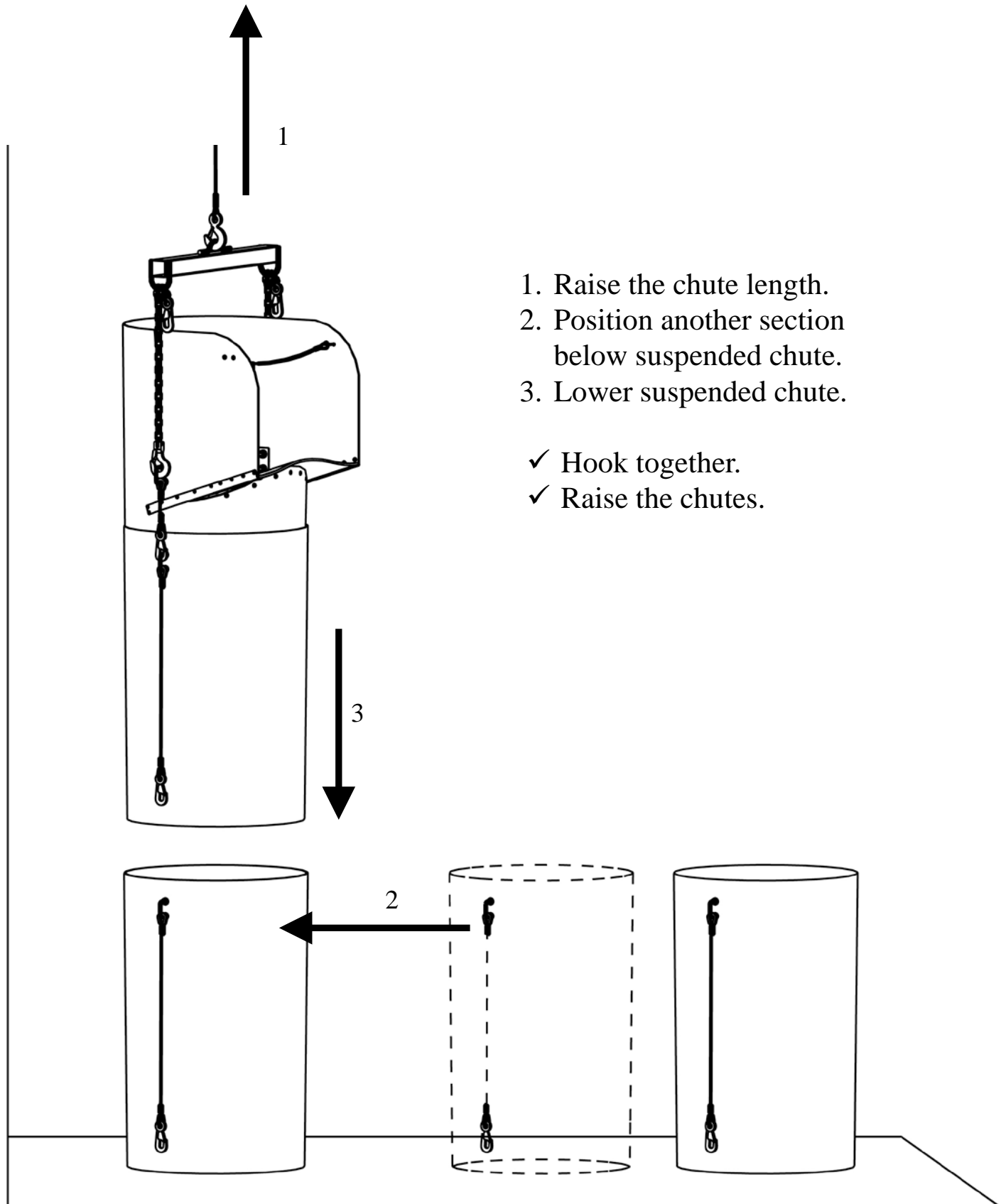

HOIST THE CHUTE SECTIONS INTO PLACE (continued)

- Repeat the last step until the uppermost section arrives at the hoist level.

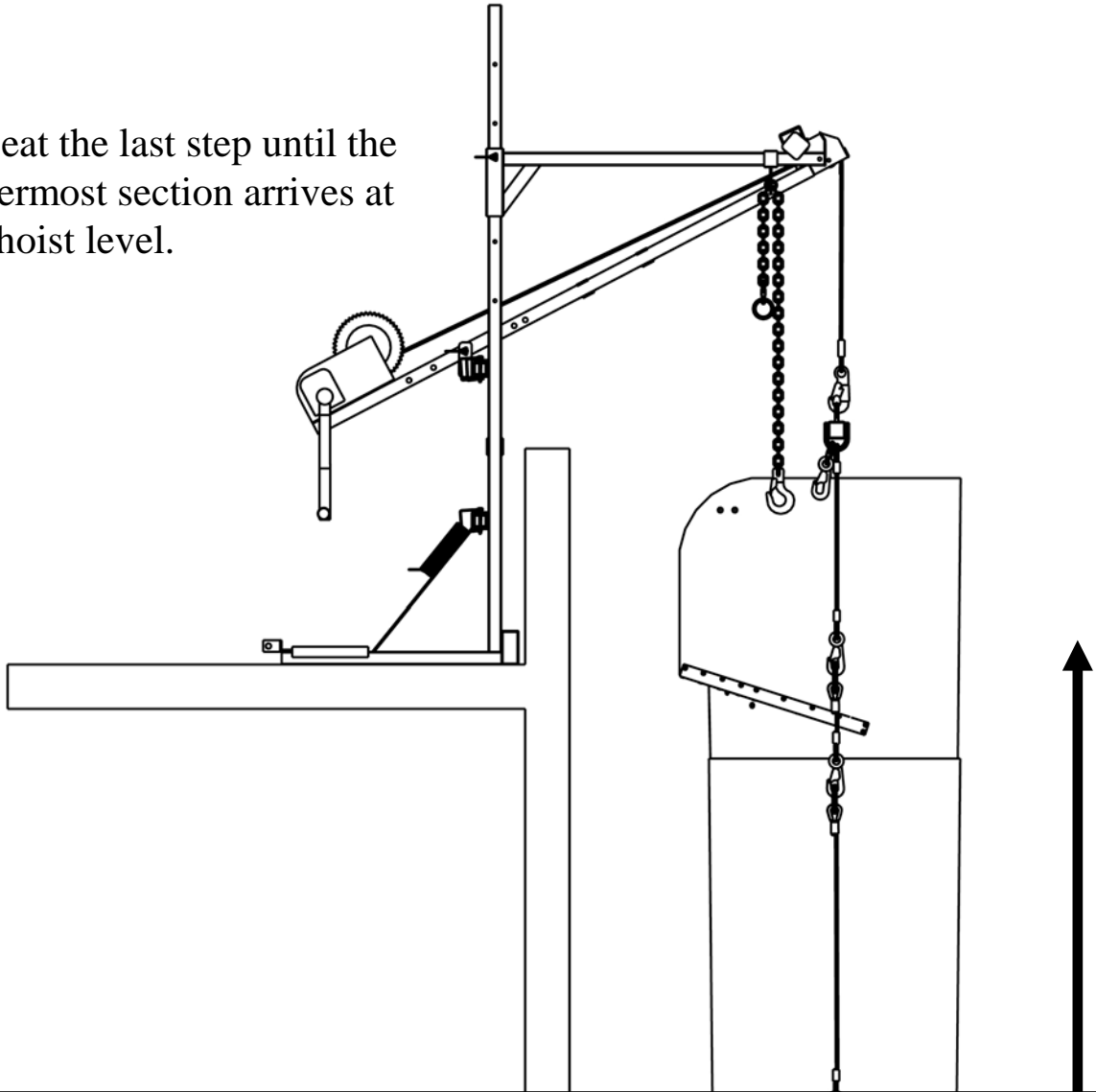

WARNING

- The SC-500-bd Bolt Down Frame has a Working Load Limit of 500 lb. (It is designed to safely lift, support, and lower a chute load weighing up to 500 lb).
- The hoist frame and/or Fishpole may fail if more than 500 lb. is applied.
- A falling chute system can seriously injure or kill.
- Do not overload the hoist frame or the Fishpole.
- Use the information in **Sections 7 & 8** to calculate the maximum number of Superchute® sections you can safely lift, suspend, & lower per frame.

19. TRANSFER THE CHUTE LOAD FROM THE LIFTING DEVICE TO THE BOOM CHAINS

Although the following sketches show the Fishpole in use, other lifting devices, such as cranes, material hoists, or boom lifts, may be appropriate as long as they can safely manage the chute load. All lifting devices require the procedure shown in this section.

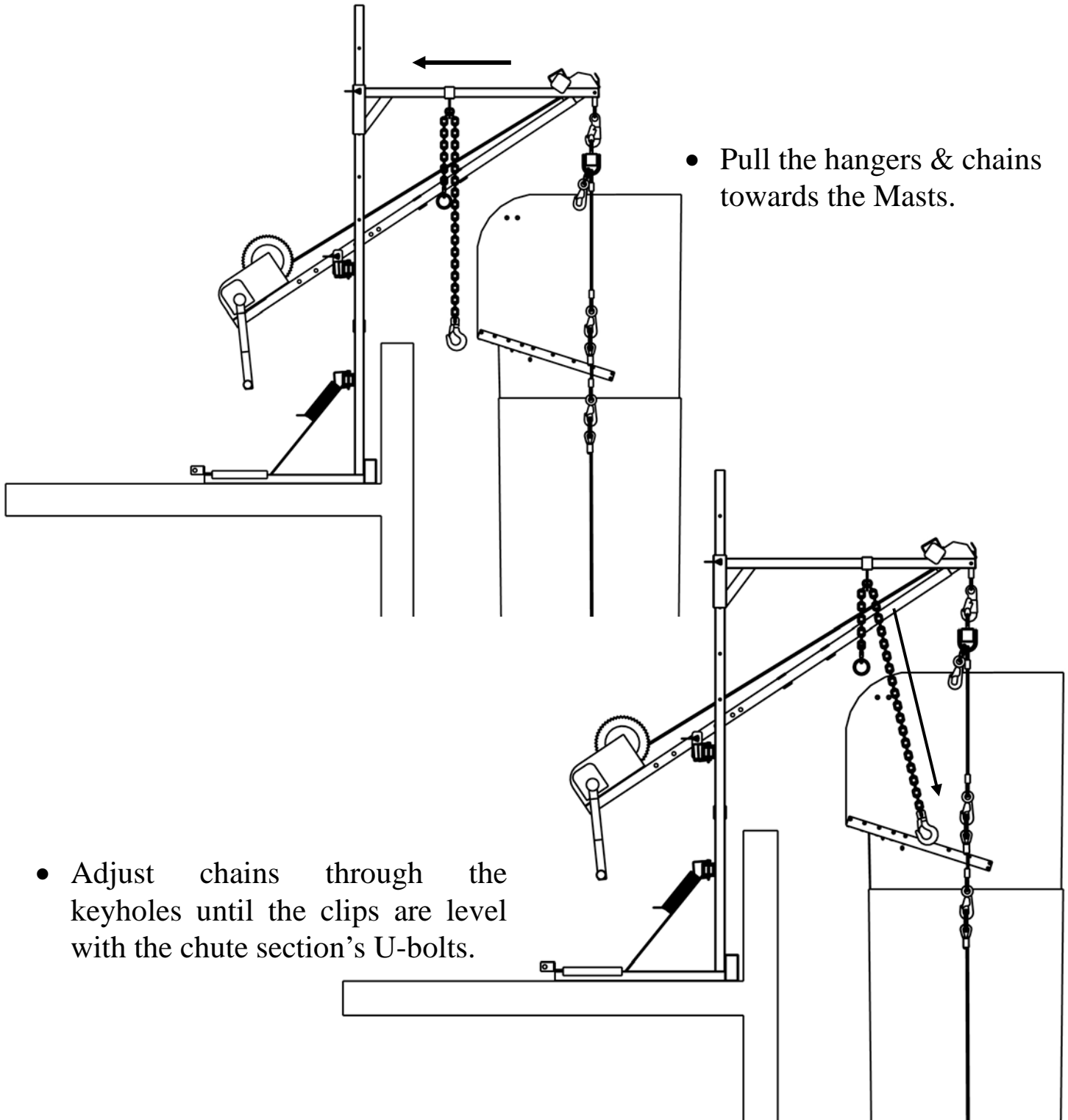

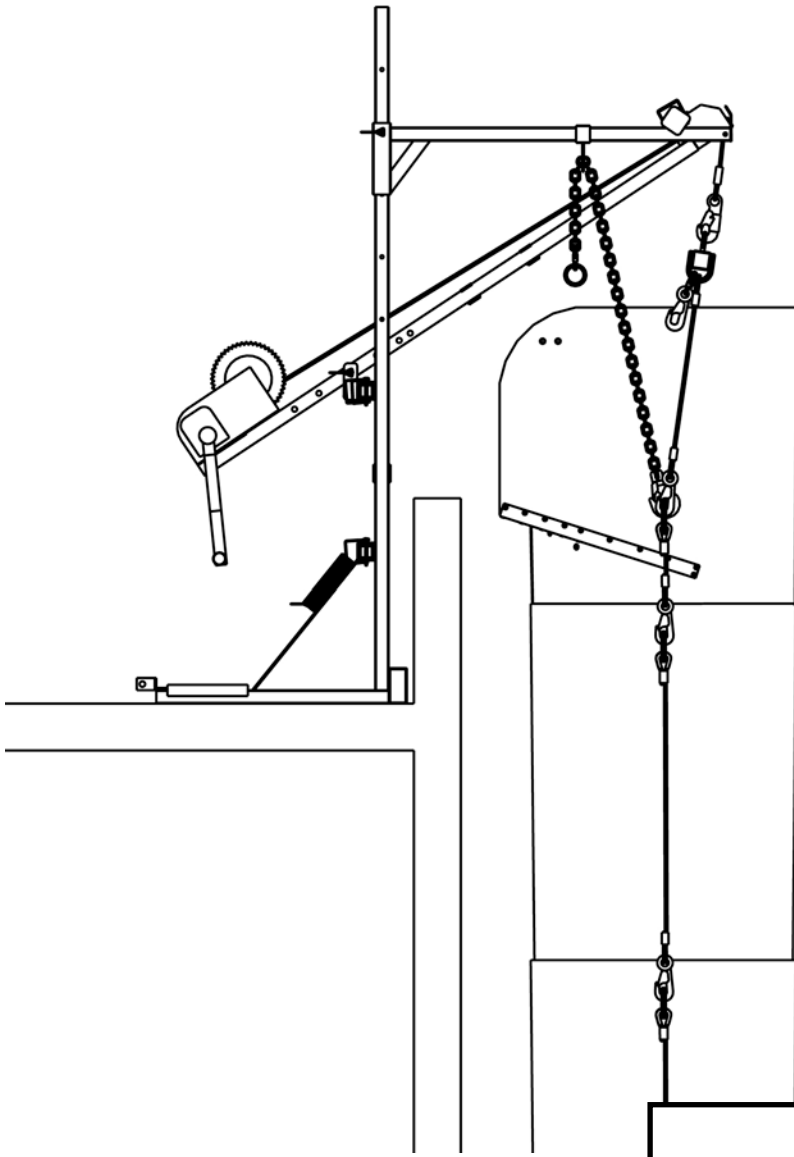

- Fine-tune the height of the chute section.
- Attach a chain clip to each U-Bolt.
- Adjust the chain lengths.
- **The chain lengths must be equal (count the links).**
If the chain lengths are not equal the weight of the chute will be unevenly distributed on the hoist frame.

- Turn winch handle counter-clockwise to lower the spreader bar.
- The weight of the chute will transfer to the boom chains.
- Unhook the Spreader Bar from the chute section's U-bolts.

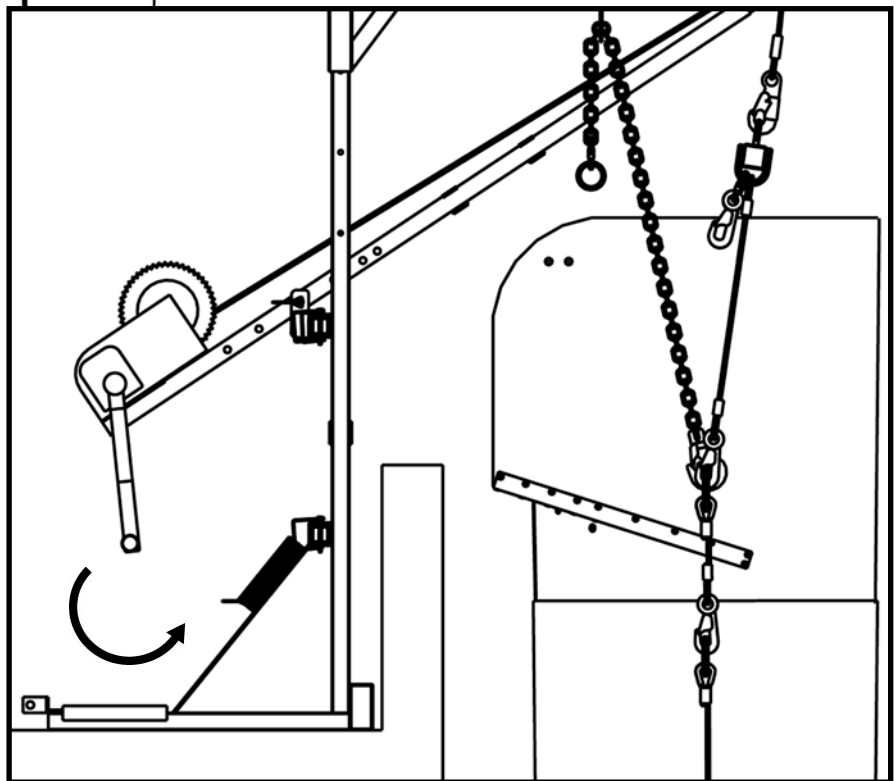

20. REMOVE THE FISHPOLE (IF APPLICABLE)

If using a crane (or similar device), then please go directly to [Section 21](#).

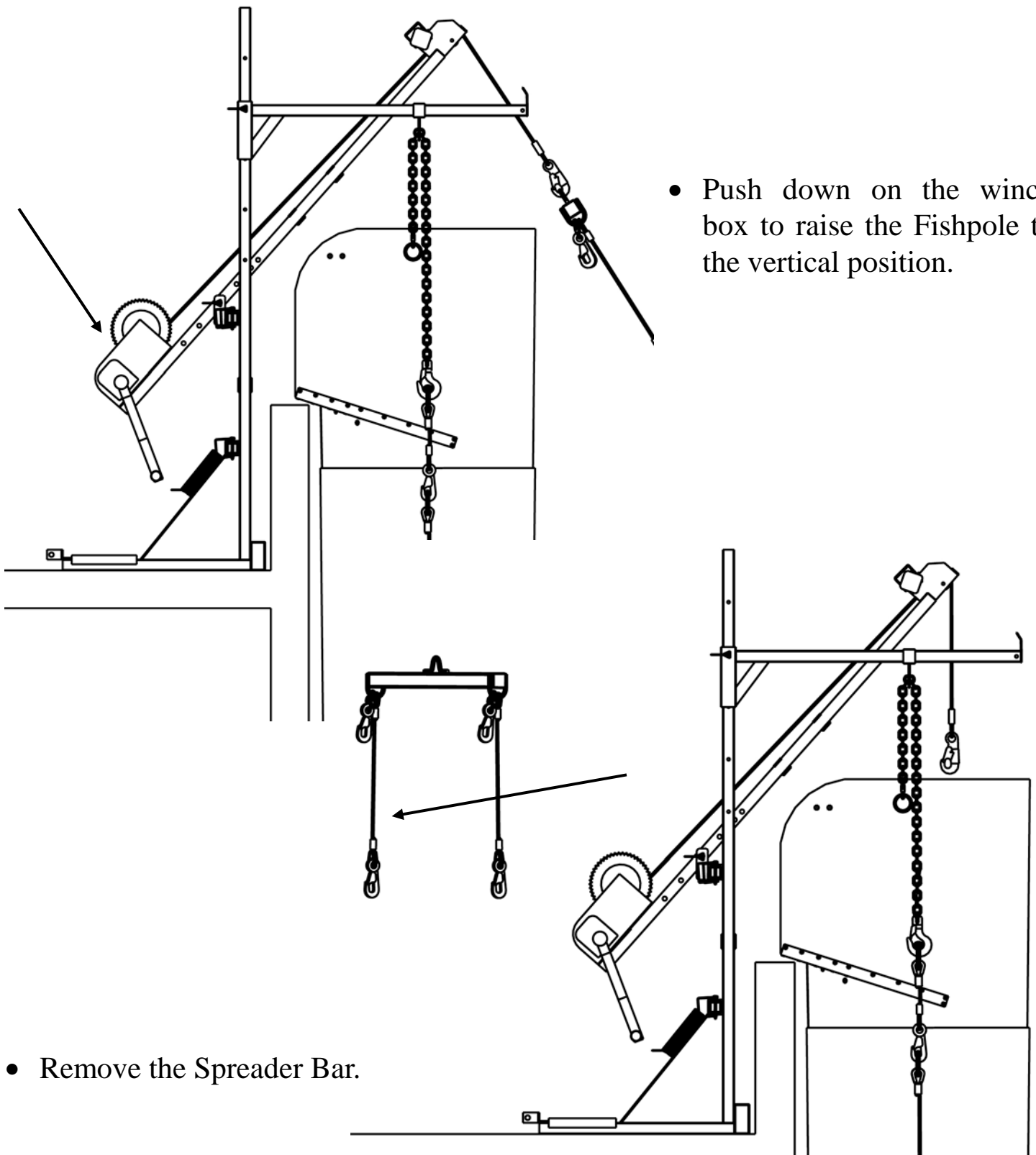

- Unpin the Fishpole and Yoke as shown.
- Detach the Fishpole & store it in a safe place along with the Yoke.

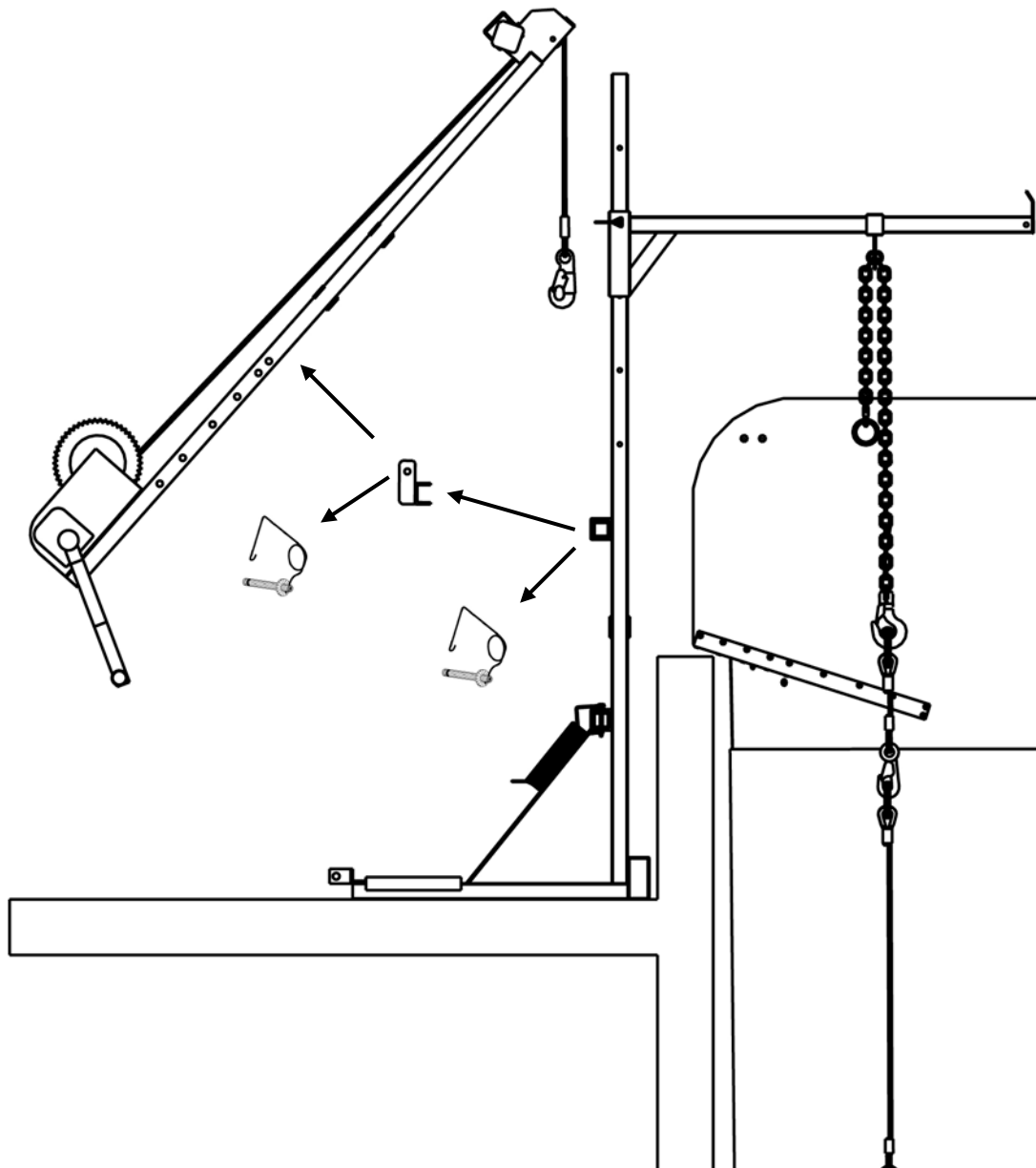

21. CONGRATULATIONS!

The installation of your SC-500-bd Bolt-Down Frame Hoist is complete!

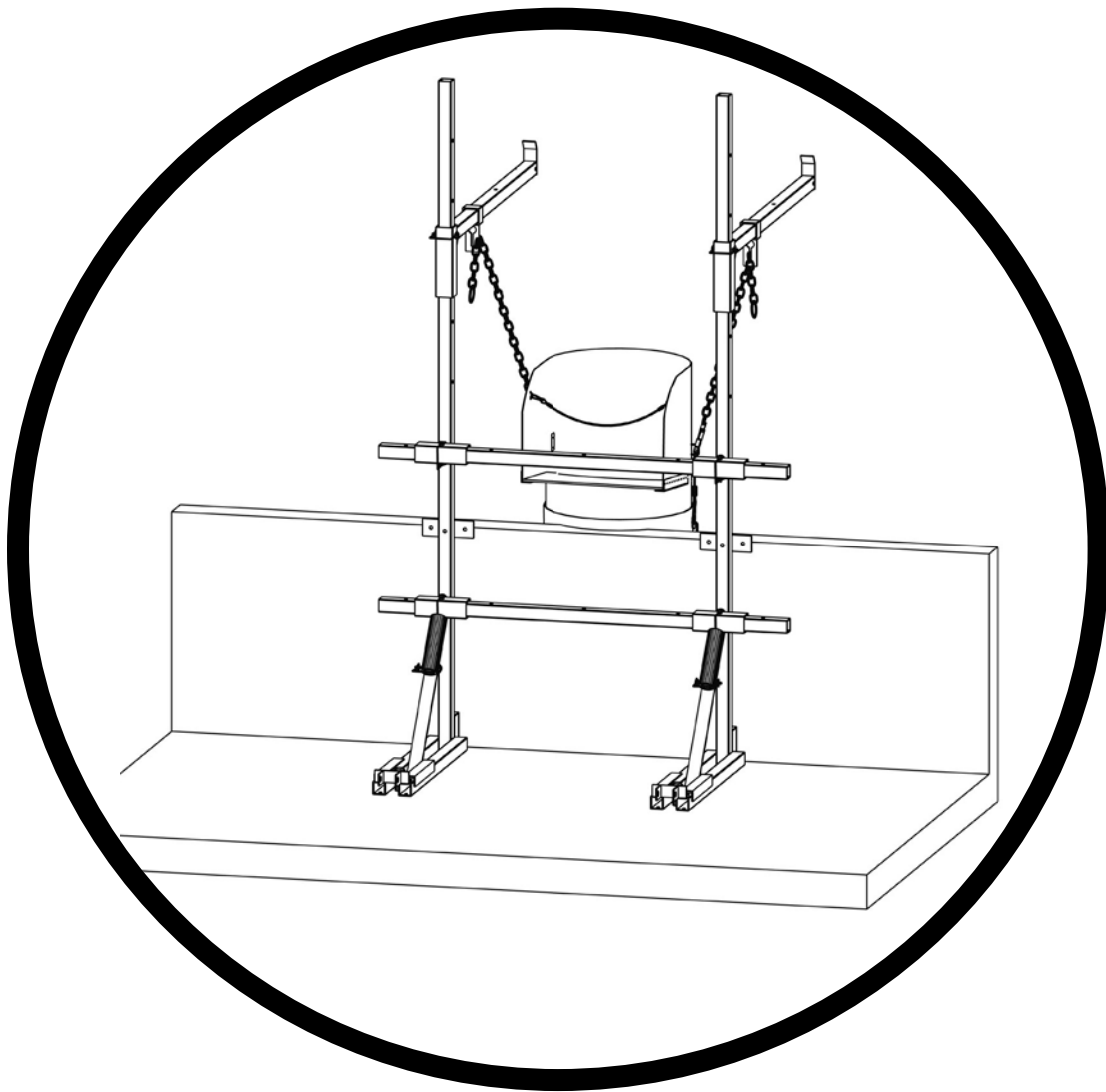

Please see the next few pages for more important information.

22. FALL PROTECTION & THE GATEKEEPER



WARNING

- The upper Tie Bar is a substantial fall prevention barrier. If the upper Tie Bar is removed, and an alternate fall prevention barrier does not exist, a person could easily fall into the chute or off the building.
- A fall from a height of 6 ft. is enough to seriously injure or kill.
- OSHA requires that fall prevention barriers be at least 42" high, plus or minus 3". Guardrail systems, parapet walls, and window sills may be acceptable fall prevention barriers provided they meet OSHA's height and strength criteria.
- The upper Tie Bar may be detached if it is interfering with the debris removal process, as long as personal fall arrest systems are used, or alternate fall prevention barriers are present.
- Keep the debris removal process quick and safe in areas without adequate fall protection by designating a worker as the **Gatekeeper**.
- The Gatekeeper is secured by a personal fall arrest system to an anchor that is independent of the chute system. Because he is protected against falls, he can work near the exposed edge. At a demarcated "stop line" (where there is no risk of falling over the edge), the Gatekeeper receives full wheelbarrows from unprotected workers. He empties the wheelbarrows into the chute and returns them to the stop line in exchange for full ones.

In the situation shown below, the parapet is less than 39" high, so fall protection is required to prevent people from falling over the edge.

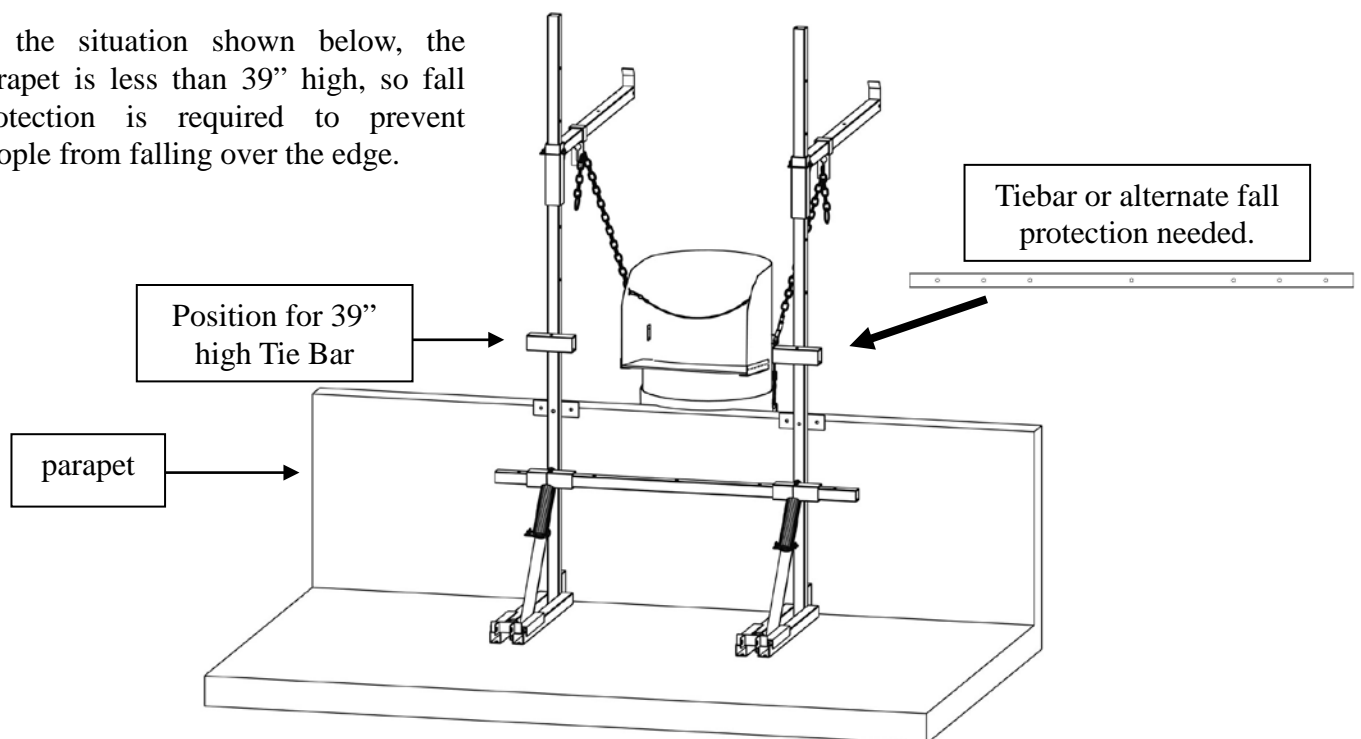

23. RAMPS



WARNING

- A ramp resting on the hoist frame could greatly increase the loading on the hoist frame.
- The load increase could cause the hoist frame to fail.
- Do NOT rest ramps on the hoist frame. Do NOT attach ramps to the hoist frame.
- Ramp designs should be approved by a structural engineer.

WRONG:

The wheelbarrow ramp increases the load on the hoist frame.

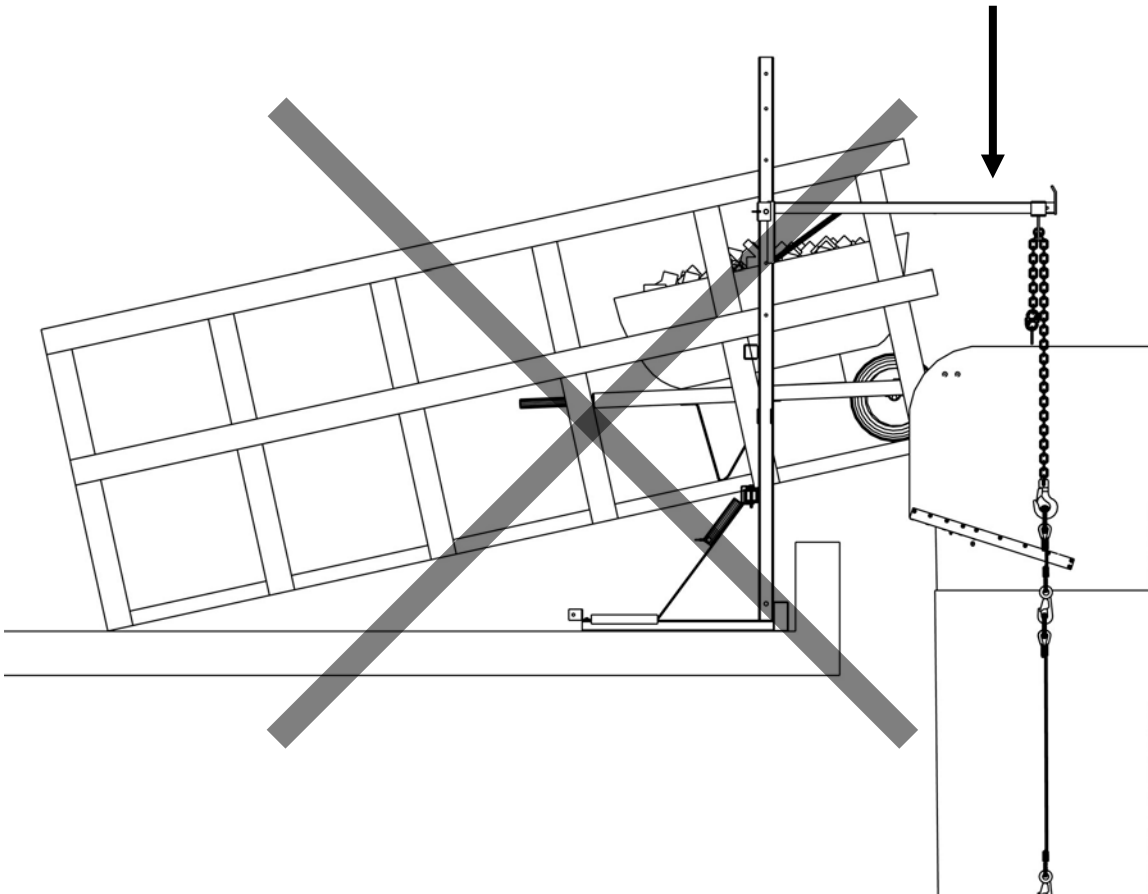

24. PIGGYBACKING

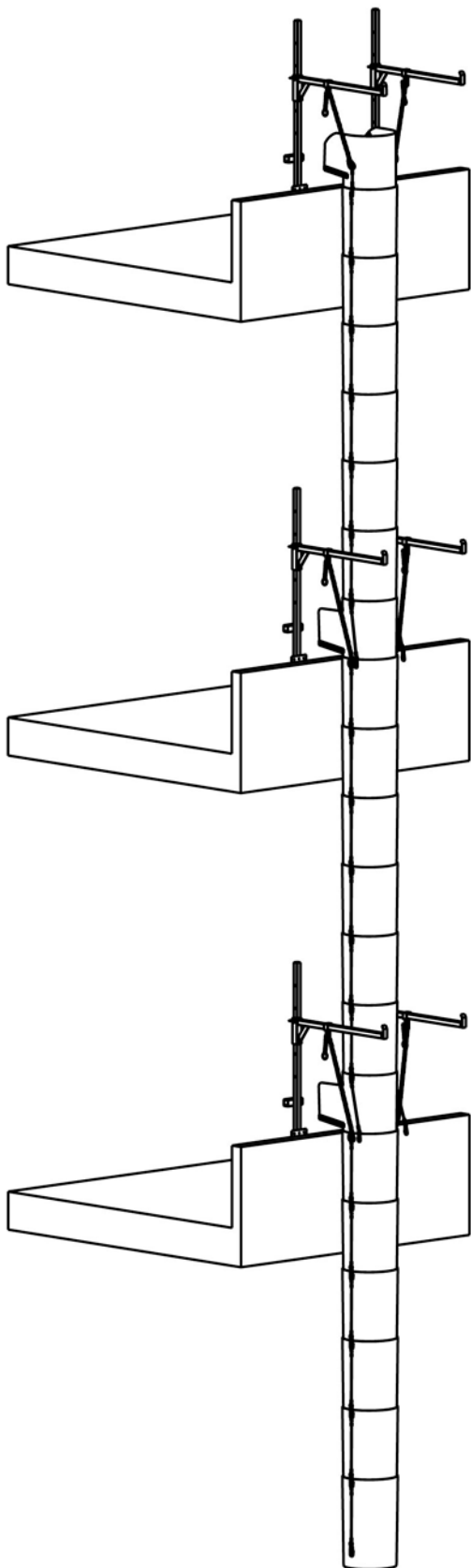

On jobs where a taller chute is needed, frames can be piggybacked approximately every 40 feet (depending on the chute diameter used) in order to achieve a maximum chute height of 200 ft.

For buildings that are growing skywards, the piggyback arrangement may be the only practical installation method. Piggybacking allows the chute to be lengthened quickly, without disturbing segments that have already been installed. As the building rises, install an additional frame on the new floor. Use either the Fishpole or a crane to lift a length of chute into the air. Chain the chute to the frame, and mate the bottom of it to the chute already in use below.

If the chute system contains door sections, the piggyback arrangement will also allow the door sections to be better aligned with the window openings.



WARNING

- A frame may fail if more than 500 lb. of load is applied.
- A falling frame and its load can seriously injure or kill.
- When piggybacking, never raise more than **one chute length** at a time. To do so risks placing the weight of many chute lengths on a single frame.
- Use the information in [Sections 7 & 8](#) to calculate the maximum number of Superchute® sections you can safely lift, suspend, & lower per frame.

25. PIGGYBACKING - SPECIAL CONSIDERATIONS

A) USE A RESTRAINT TO KEEP CHUTE LENGTHS FROM KISSING

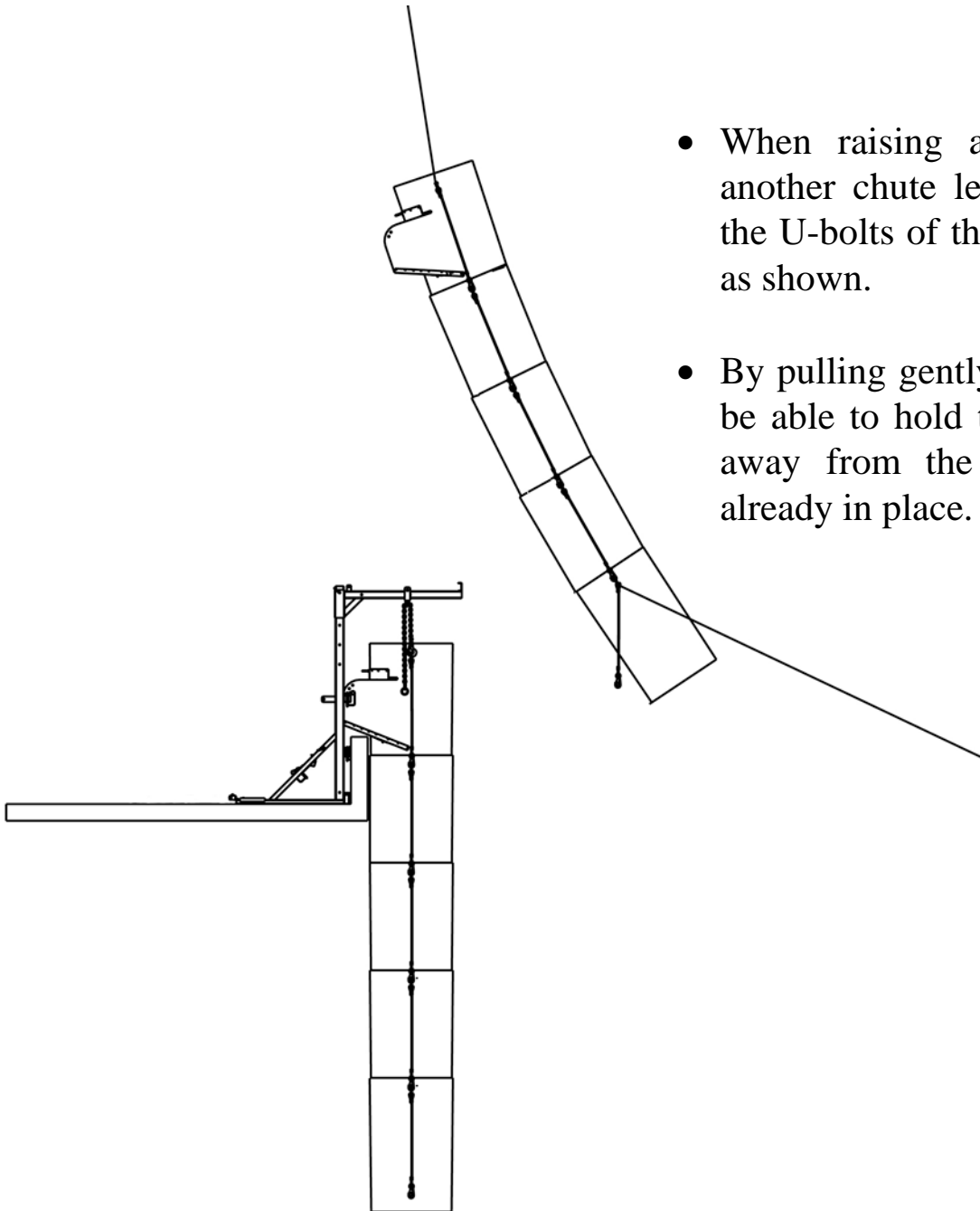

- When raising a chute length above another chute length, attach a rope to the U-bolts of the lowest chute section, as shown.
- By pulling gently on the rope, you will be able to hold the rising chute length away from the chute length that is already in place.

B) DO NOT LINK CHUTE LENGTHS USING THE CABLE ASSEMBLIES



WARNING

- A single frame could be forced to carry the weight of many chute lengths if the chute lengths are linked together using cable assembly pairs.
- A frame may fail if more than 500 lb. of load is applied. A falling frame and its load can seriously injure or kill.
- Do NOT use cable assembly pairs to link chute lengths. Where two chute lengths meet, use two 4 foot lengths of the supplied Superchute® Breakaway Container Cord to create a weak linkage, which can fail if necessary.

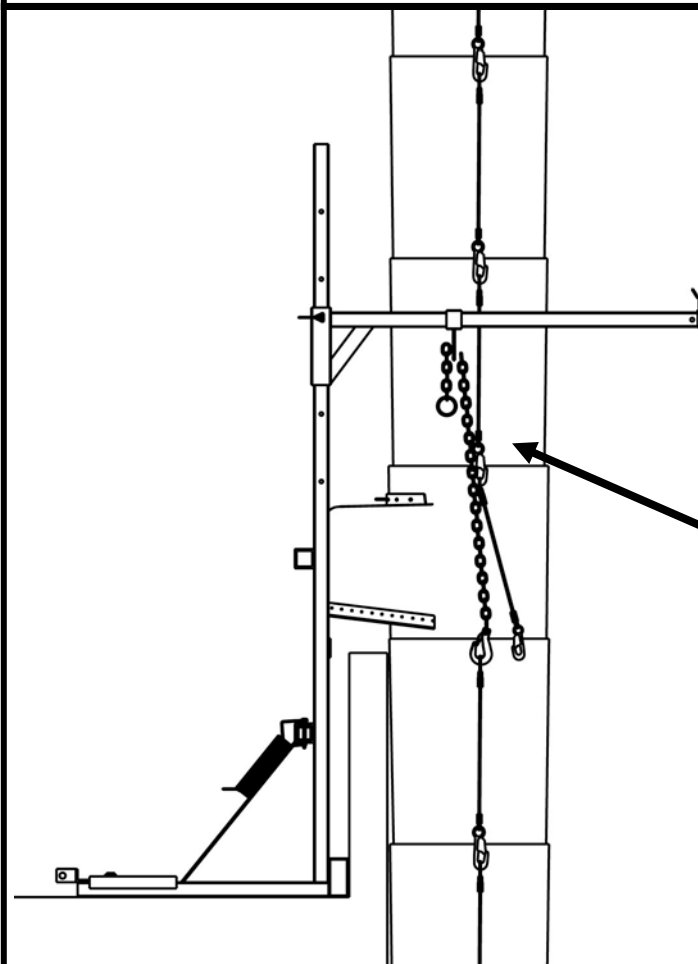

The cable assembly pair is not used where the chute lengths meet. Use Container Cord (or similar weak cord) to link the chute lengths instead.

Chute lengths must hang independently of one another. Should a major blockage occur in a length, it must be able to break and fall away, without pulling down other chute lengths.

If a blocked length were attached by cable assemblies to the length above it, then an unintentional transfer of weight could occur, whereby a single frame is forced to support the weight of more than one chute length.

To prevent an unintentional transfer of weight the joint between the two segments should be secured using a breakaway cord like Superchute® Container Cord (breaking strain 700 lb). Do not link chute lengths together using the chute's cable assemblies (breaking strain 10,000 lb).

Please call Superchute Ltd. if you are unclear on this concept.

C) LEAPFROG THE TOP HOPPER ON A GROWING BUILDING

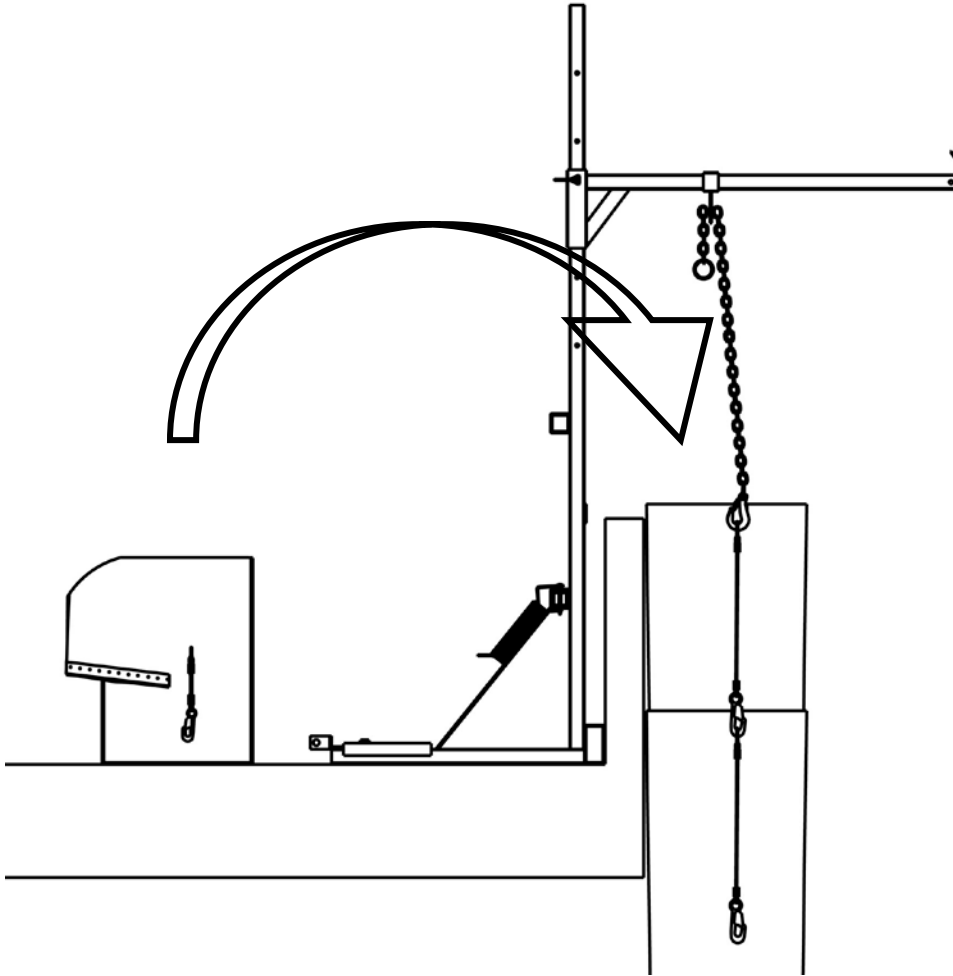

Tie the boom chains to the topmost regular section.

Place the Top Hopper on top of the chute length.

Placing the Top Hopper in this manner will allow it to be easily removed later when the chute system needs to be expanded.

- To prevent the Top Hopper from falling off the chute length, always use its two cable assemblies to secure it to the regular section below.

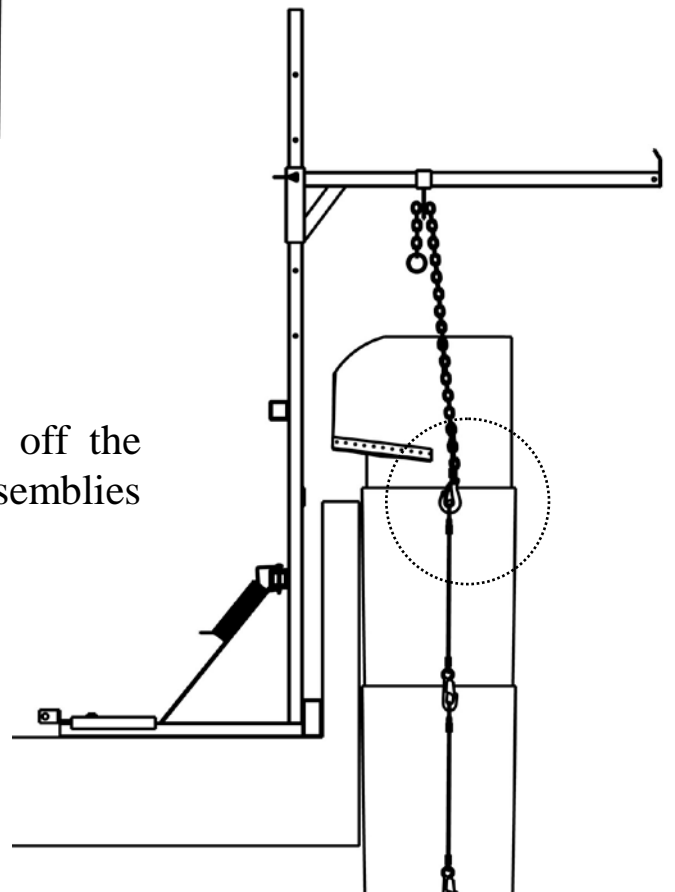

D) OVERVIEW OF THE LEAPFROG PROCEDURE:

1. The Top Hopper is removed from the chute length. It is brought to the floor above.
2. A new chute length is raised. A Door Section can be used to replace the Top Hopper's previous location.
3. The Top Hopper is placed on top of the new chute length. Its cable assemblies are connected to the U-bolts of the regular section below.

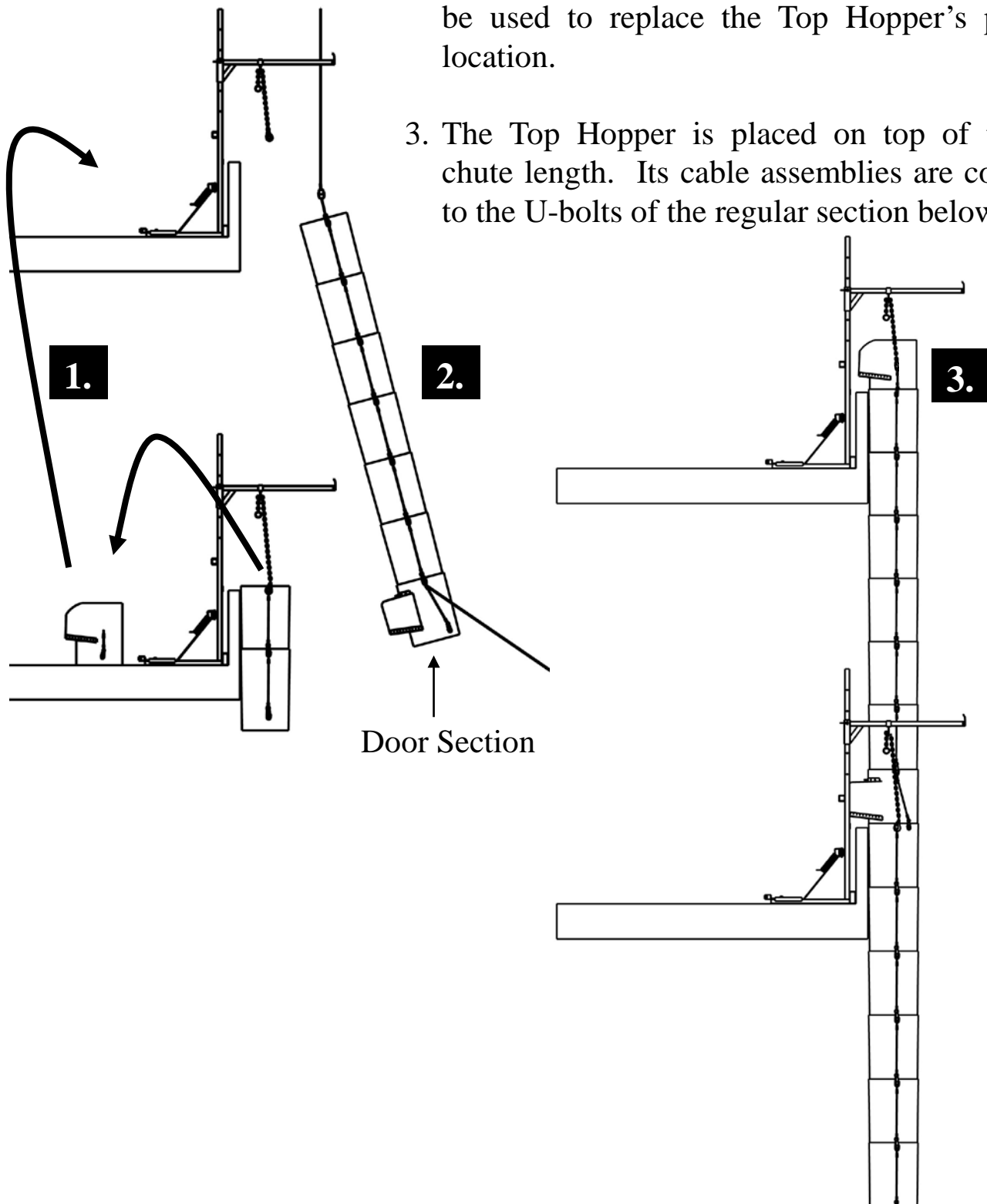

26. DE-INSTALLATION OF THE HOIST

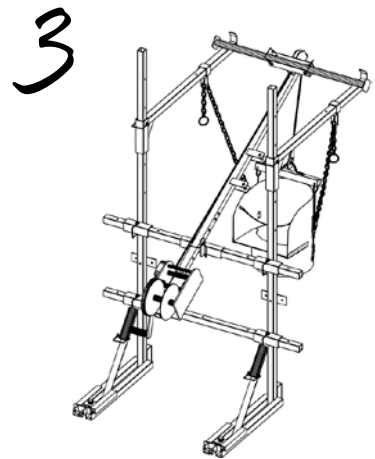
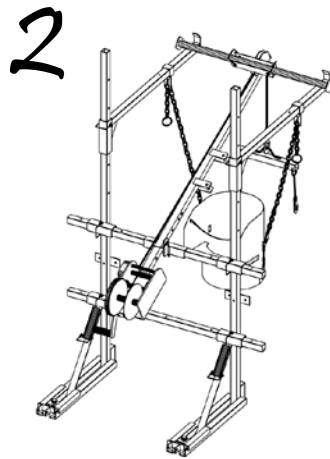
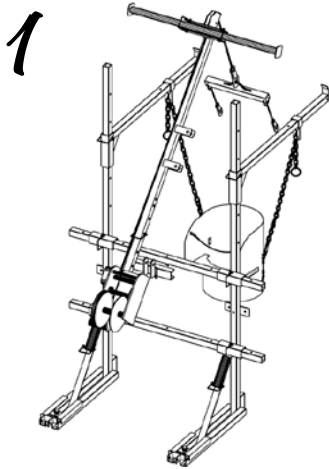

- Using the Fishpole or a crane, transfer the chute load from the booms, and lower the chute.

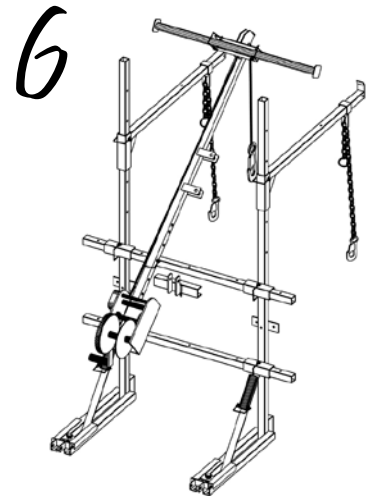
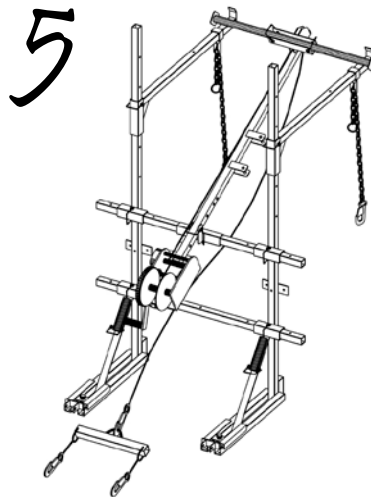
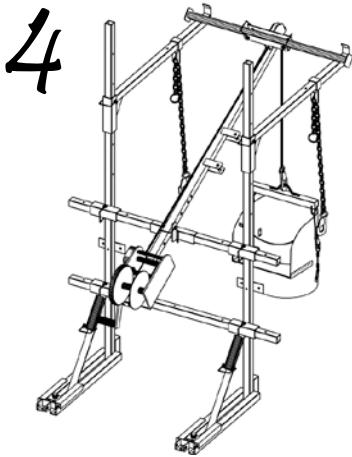

- After lowering the chute, wind up the cable, remove the Spreader Bar, and remove the Fishpole.

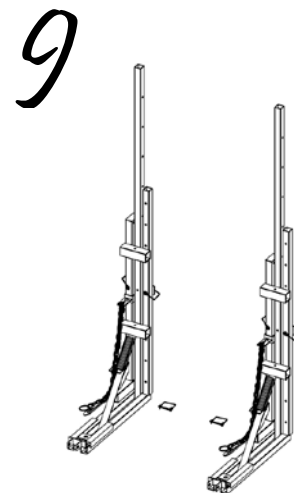
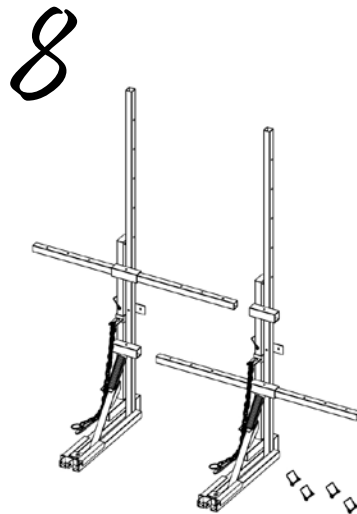
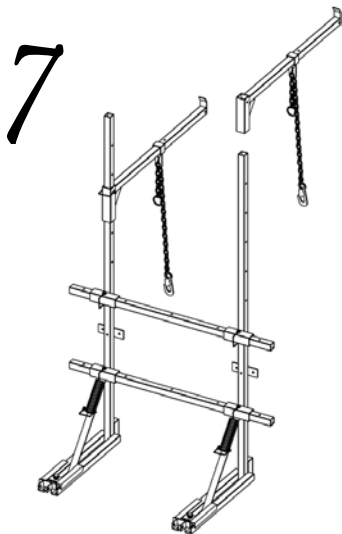

- Remove the Booms & Tiebars. Store them on the Masts. Remove bolts or Counterweights. Store Frame.

APPENDIX A: WARRANTY

Superchute® chute hoists are made for heavy wear, but like all tools, time and use will take its toll. There is no warranty for wear and tear, or misuse of the hoist. Superchute® warrants all products against manufacturing defects, which must be reported in writing to Superchute® Ltd. upon receipt of goods. Thorough overhaul servicing is offered by Superchute® Ltd.

APPENDIX B: STAY INFORMED

The Superchute® factory sends out regular notices regarding new products, changes, recalls, and upgrades. Stay informed by filling out the form below and sending it in. Please feel free to enclose any other comments. Thank you for choosing Superchute® Ltd.

Your Name: _____	E-mail address: _____
Company: _____	
Address: _____	Website: _____
Phone: _____	
Fax: _____	
Number of chute sections owned: _____	
Diameter(s) of the chute sections: _____	
Date(s) of purchase: _____	
Name of the Supplier: _____	
Number of chute hoist(s) owned: _____	
Models and serial numbers: _____	
Date(s) of purchase: _____	
Name of the Supplier: _____	

Fax to: 514-365-8987, or mail to: Superchute® Ltd., 8810 Elmslie Road, Montreal, QC, Canada, H8R 1V6

APPENDIX C: PARTS LIST

BOLT-DOWN HOIST MODEL SC-500-bd

1. Frame Components

Quantity

Factory

Office
Initials:

	Quantity	Factory	Office Initials:
Masts	2		
Booms with chains	2		
Tie bars	2		
½" diameter locking pins	6		
½" diameter locking pins - SPARE	2		

2. Hoisting Components

Standard Fishpole + sheave + Shelby winch + cable	1		
Special Fishpole + sheave + Tirfor winch + cable + reeler	1		
Fishpole Yoke (labeled Yoke 500)	1		
Reeler Arm + Reeler Arm Yoke (labeled SC-500-bd)	1		
Outer cross bar	1		
½" diameter locking pins	4 (st) 6 (sp)		
Light Duty Spreader Bar (WLL 1000 lb.)	1		
Leave in Place Lifting Bar (WLL 2000 lb.)	1		

3. Anchor Bolts

HILTI®	Model: HSL M12/50	2		
HILTI®	Model: HSLB M12/50	2		
Power-Bolt™	Model: 6945	2		
Superchute® Thru-Bolt	Length: 18" or 36"	2		

4. Counterweight Kit

Back Balance Beams	2		
Counterweights	12		
½" diameter locking pins	4		
Padlocks	2		

PHOTOCOPY THIS PAGE AND ATTACH TO CLIENT'S FILE

APPENDIX D: FACTORY CERTIFICATE

I _____ certify that the frame was fully assembled & checked prior to leaving the factory.
(use capitals)

signed: production crew member

date

Serial Number(s):

PHOTOCOPY THIS PAGE AND ATTACH TO CLIENT'S FILE

APPENDIX E: GLOSSARY

Breaking Strain: The average load at which a new component (for example: a cable or chain assembly) will fail. The breaking strain is obtained by applying direct tension to a component at a uniform rate of speed, in a testing machine.

Chute: A series of linked chute sections that are used to convey debris.

Chute Hoist: An engineered device that has been designed specifically to raise, anchor, and lower a chute. A chute hoist consists of a support frame and a detachable winch apparatus (known as the Fishpole). The support frame, without the Fishpole, can still be referred to as a chute hoist.

Chute Length: A short series of chute sections whose total weight is less than the Hoist Frame's load capacity. For example, workers using the SC-500-bd should build chute lengths weighing less than 500 lb.

Chute Sections: Modular conical tubes that can be linked together in series to form a chute.

Chute System: A suspended chute and the anchors (including chute hoists) that support it.

Design Factor: Also known as the "safety factor", it is a product's theoretical reserve capacity. The design factor is calculated by dividing the Breaking Strain by the Working Load Limit. The design factor is generally expressed as a ratio, for example: 10 to 1, or 10:1.

Users: The term "users" includes planners, supervisors, installers, and end-users of the chute hoist.

Working Load Limit:

The maximum load which can be applied to the component, when the component is new, or in "good as new" condition, and when the load is applied in the intended manner. This term can be abbreviated to WLL.

The Working Load Limit of the SC-500-bd chute hoist is 500 lb.

APPENDIX F: WINCH INFORMATION (IF APPLICABLE)

If a Standard Fishpole is part of your SC-500-bd Bolt Down Frame, then the following information applies:

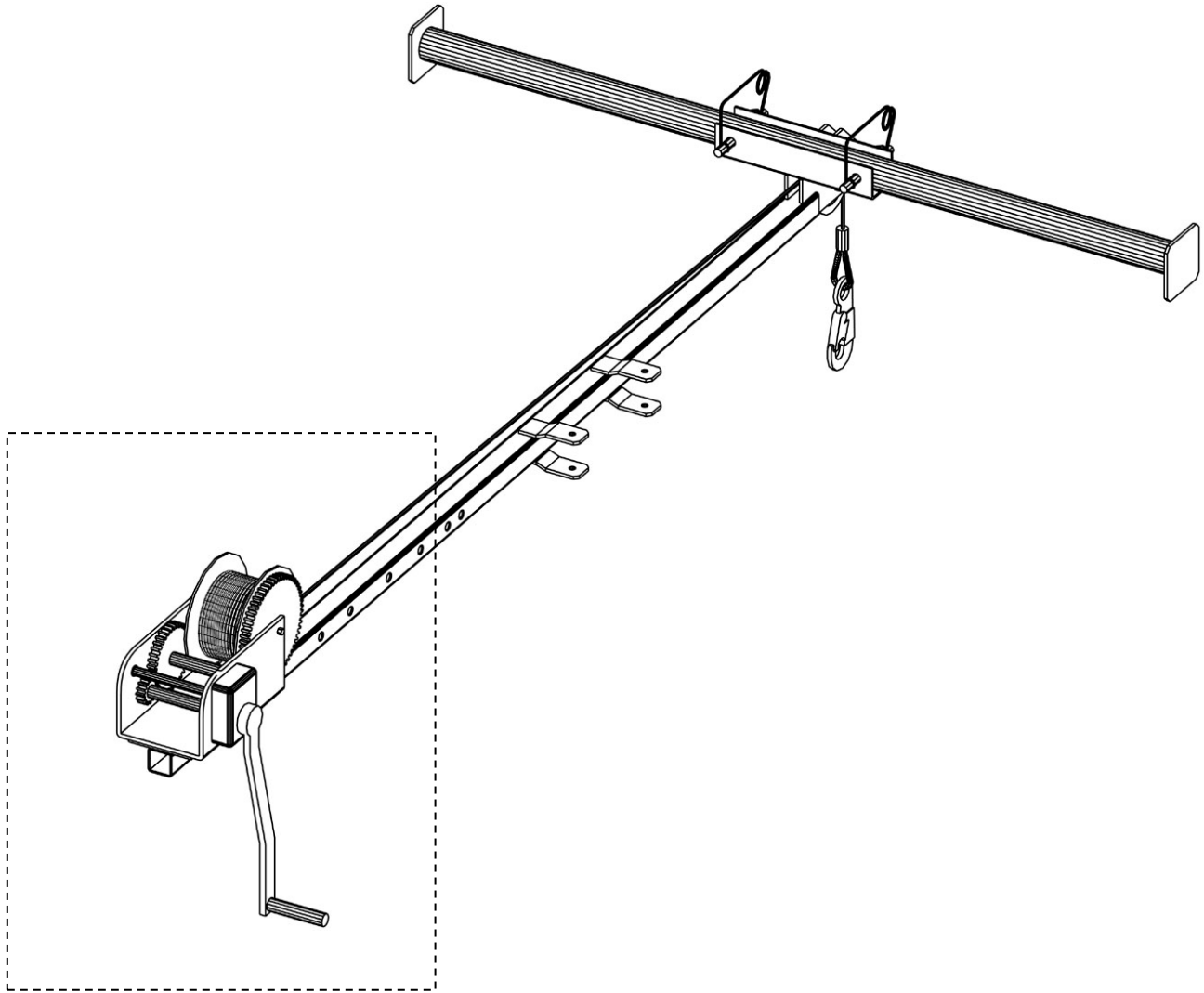

The Fishpole is equipped with a drum-style winch.

Winch manufacturer: Shelby Industries
Telephone: (502) 633-2040
Winch model: 5353
Further information: See the next 4 pages for manufacturer's information on the winch.

SHELBY INDUSTRIES WINCH MANUAL

OWNER'S MANUAL & PARTS LIST WINCH MODEL 5353

2500 Lb. (1134 kg) Maximum Rated Line Pull

WARNING

THIS EQUIPMENT SHOULD NOT BE INSTALLED, OPERATED OR MAINTAINED BY ANY INDIVIDUAL WHO HAS NOT READ ALL THE CONTENTS OF THIS OWNER'S OPERATING MANUAL.

FAILURE TO READ AND APPLY THE INSTRUCTIONS AND WARNINGS CONTAINED HEREIN CAN RESULT IN SUDDEN FAILURE OF EQUIPMENT, PROPERTY DAMAGE AND SERIOUS INJURY.

I. ASSEMBLY INSTRUCTIONS

- A. **HANDLE.** Insert handle (item 6, Fig. 1) on threaded brake assembly shaft. Thread handle to point of engagement (touching) of brake pad.
- B. **HANDLE RETAINER ASSEMBLY.** Insert Bolt (Item 1, Fig. 1) through lockwasher (Item 2, Fig. 1), flatwasher (Item 3, Fig. 1), spacer (Item 4, Fig. 1) and spring (Item 5, Fig. 1- spring will fit over spacer). Recheck Fig. 1 to ensure proper order of assembly.

Install bolt containing assembled retainer parts (Fig. 1) into threaded end of brake shaft and tighten bolt securely.

II. MOUNTING INSTRUCTIONS

- A. This winch is designed to be attached to a mounting plate or structure capable of supporting the load that it is intended to pull (lift).
- B. The winch should be mounted, using five 3/8" dia. S.A.E. Grade 5 bolts (not supplied). Four bolts should attach the winch to the mounting structure utilizing the outside rear holes or slots. The fifth bolt should be inserted through the winch frame and mounting structure in a manner to utilize the foremost remaining frame slot (hole) (Fig. 2).

III. CABLE ASSEMBLY INSTRUCTIONS

- A. **CABLE ATTACHMENT.** Winch model 5353 is designed for up to 65 ft. of 5/16" dia., 7 x 19 galvanized aircraft-quality cable.
 1. Feed cable into bottom of drum (item 7, Fig. 3). From inside drum, thread the cable through one round hole in the drum side, until it extends 1-1/2" past the two square holes.
 2. Clamp the cable to the outside of the drum with keeper parts (items 8, 9, 10, Fig. 3). Be sure that carriage bolt heads are on the inside of winch drum.

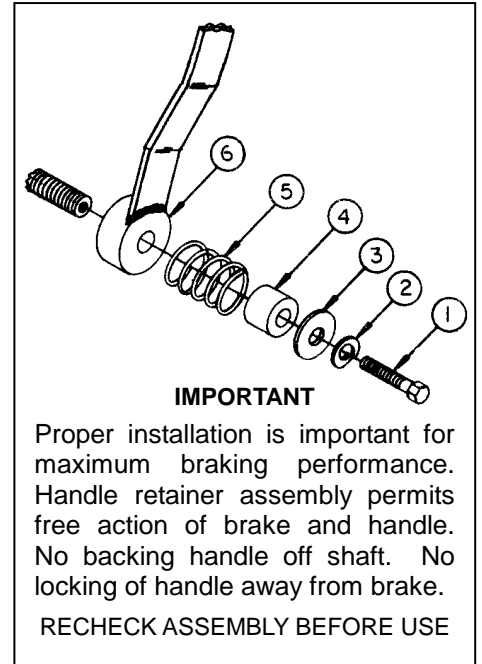

Fig. 1: Handle Retainer Assembly

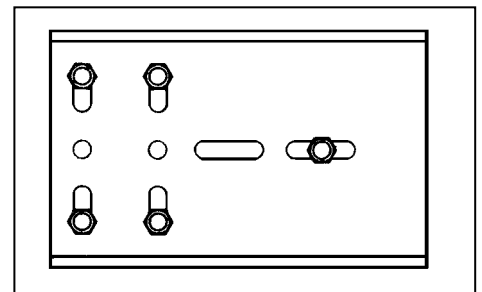

Fig. 2: Mounting Instruction

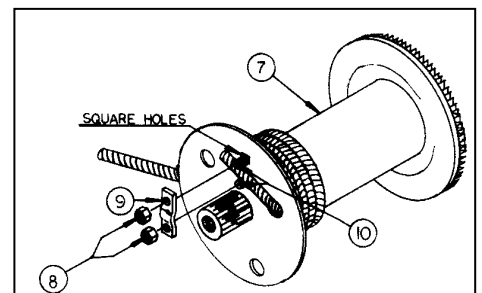

Fig. 3: Cable Installation



CAUTION

1. Always be sure cable is strong enough to support the load to lifted.
2. Always inspect cable and attachment hook before each use to insure they are not damaged.
3. Replace cable if worn, frayed or kinked. If the cable or hook breaks, the cable can act like a whip and inflict serious injury to anyone in the path of its movement.
4. Never stand alongside winch cable, or guide the cable with your hands.
5. Never fully extend cable and ALWAYS keep three (3) complete wraps of cable around drum.
6. Always be sure cable is pulling straight off winch – not at an angle. This will prevent cable from rubbing against winch drum, avoiding cable damage.

IV. OPERATING PROCEDURE

- A. **TO REEL IN OR LIFT LOAD.** This winch is designed to lift a load (reel in) by turning the hand crank in a clockwise direction. This action will produce a clicking sound inside the winch mechanism. To **LOCK** the load at any desired position, release handle slowly.
- B. **TO REEL OUT OR LOWER LOAD.** To lower load (reel out), turn handle crank in a counter-clockwise direction. To **LOCK** load in any desired position, turn handle clockwise until at least (2) clicks (approximately 8” movement of handle) are heard inside the winch mechanism before releasing handle.

CAUTION: If hand slips off handle while turning counter-clockwise, the brake will prevent the handle from spinning rapidly backwards. **NOTE:** The brake is not fully locked until the handle is turned clockwise far enough to hear two (2) clicks of the ratchet.

WARNING: Sufficient load must be applied to the cable to overcome internal resistance and operate brake properly. **NEVER CONTINUE TURNING THE HANDLE COUNTER-CLOCKWISE IF THE CABLE DOES NOT KEEP MOVING OUT.** This will disengage the brake mechanism and can create an unsafe or hazardous condition. **MINIMUM OPERATING LOAD REQUIREMENTS – Model 5353 – 525 lbs.**

The brake mechanism under continuous long periods of lift and lower movement will get **HOT**.
DO NOT TOUCH BRAKE MECHANISM UNDER THESE CONDITIONS.

V. MAINTENANCE INSTRUCTIONS

- A. **LUBRICATION.** All gears must be clean and lubricated (auto-type grease) to ensure proper and safe operation. All shafts, bushings and ratchet parts must be clean and wet with oil (auto-type 10W-30) to ensure proper and safe operation.
- B. **BRAKE DISC.** Brake disc wear can be inspected by removing handle retainer assembly, handle and brake disc cover. Brake discs should be replaced if the thickness is less than 1/16”, cracked or broken. **DO NOT USE OIL OR GREASE ON FIBRE BRAKE FACES.**

WARNING: If brake disc mechanism operates intermittently or erratically, brake disc inspection should be accomplished.

- C. **BRAKE RATCHET MECHANISM.** Check ratchet operation by listening for “clicking sound” when cable is reeled in (turn handle clockwise). Also, when the cable is reeled out, there will **NOT** be a clicking sound of the ratchet. Brake ratchet parts can be inspected for worn parts and unsafe conditions by removing handle retainer assembly, handle and disc cover.

CAUTION: CARE MUST BE TAKEN DURING REASSEMBLY TO ENSURE THAT ALL PARTS ARE INSTALLED CORRECTLY FOR PROPER OPERATION.

VI. PARTS LIST

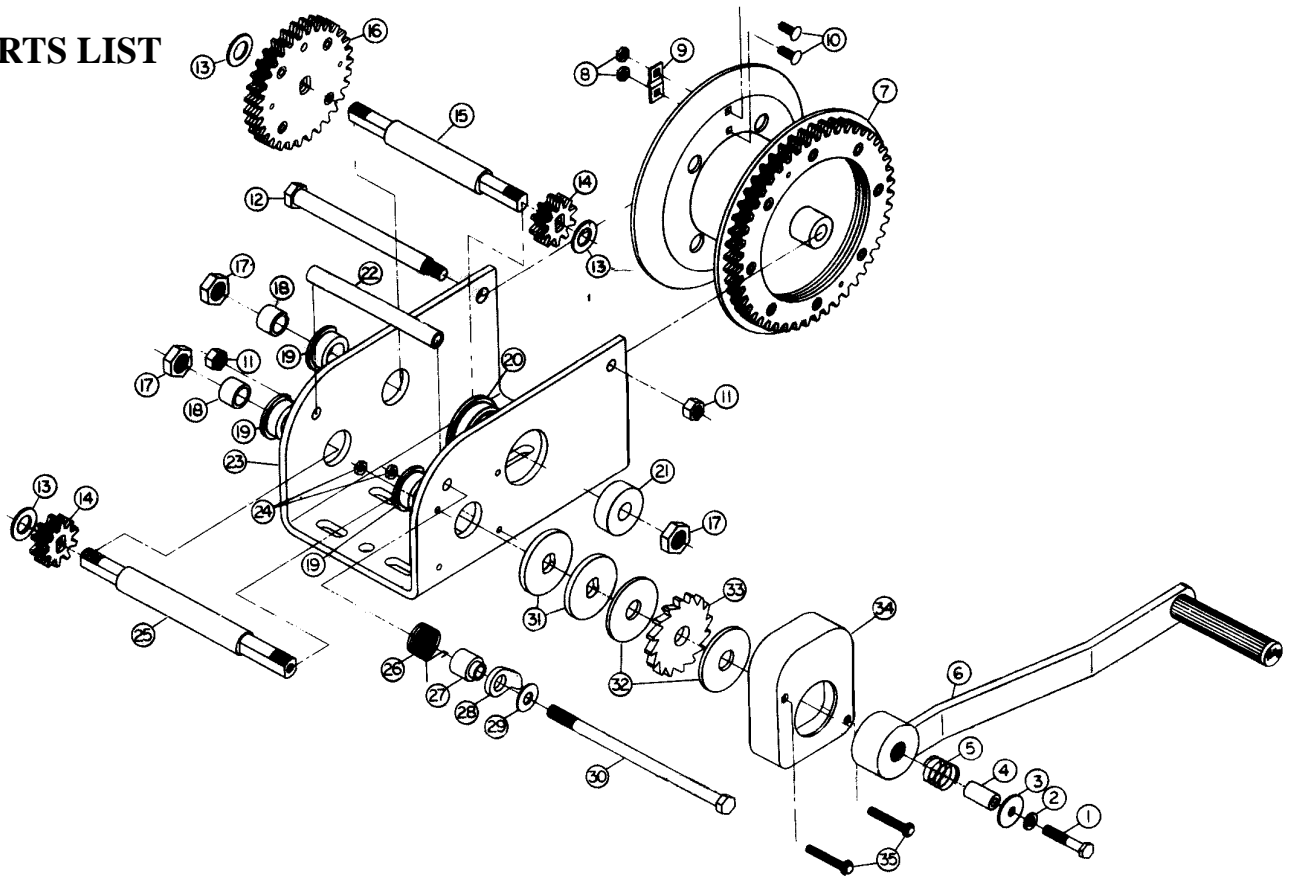

ITEM	DESCRIPTION	PART NO.	KIT NO.
1	¼"-20 x 1 ½ Hex screw	0913-03	
2	¼" Lockwasher	2524-03	
3	¼" Wide Flatwasher	0917-07	5444-81
4	Handle Retaining Spacer	1907-02	
5	Spring	0940-00	
6	Handle	2089-04	
7	Reel Assembly	0840-05	
8	10-24 Hex Nut (2)	2706-03	
9	Cable Keeper	2704-03	5441-81
10	10-24 x 5/8 Carriage Bolt (2)	2705-03	
11	3/8" Locknut (2)	1873-03	
12	Reel Bolt	2627-03	
13	Washer (3)	0232-03	
14	Pinion Gear (8)	0776-03	
15	Front Shaft	1873-05	
16	Pick-Off Gear Assembly	0951-05	
17	9/16" Locknut (3)	0673-03	
18	¾ O.D. Bearing (2)	1855-02	

ITEM	DESCRIPTION	PART NO.	KIT NO.
19	¾ I.D. Bushing (3)	2679-09	
20	1 ½ I. D. Bushing	0969-07	
21	1 ½ O. D. Bearing	0970-04	
22	Frame Spacer	1877-04	
23	Frame	0460-07	
24	10-32 Locknut (2)	2713-03	
25	Back Pinion Shaft	1872-06	
26	Pawl Spring	1909-05	
27	Pawl Spacer	1890-05	
28	Pawl	1891-07	
29	Washer	0904-03	
30	Pawl Bolt	0968-01	
31	Brake Backup Plate (2)	1878-09	5443-81
32	Brake Pad (2)	0846-06	
33	Brake Ratchet	1906-06	
34	Cover	1915-05	
35	10-32 x 1 ¾ Cover Screw	0874-07	

- Please order by specifying: Model Number, Name of Part or Kit, Part or Kit Number.
- Replacements parts are available from your dealer or the factory.
- If kit number covers a combination of part numbers, parts are sold only by kit number.



CAUTION

THIS WINCH IS NOT DESIGNED TO BE USED FOR HOISTING OR TRANSFER OF PEOPLE OR HOISTING LOADS OVER PEOPLE-OCCUPIED AREAS.

1. NEVER leave a weight hanging by the winch while the winch is unattended, as unauthorized persons may attempt to operate the winch, thereby creating an unsafe condition.
2. NEVER exceed maximum rated line pull (stamped on winch). Exceeding this rating could cause failure of the winch, serious injury to the operator, bystanders and damage to equipment.

NOTE: Maximum rated line pull for Model 5353 is 2500 lbs. (1134 kg) for the first layer (minimum of 3 wraps) of line on the drum, and 1675 lbs. for full drum rating.

As more line is wrapped on the drum, the mechanical advantage of the winch is reduced and the rating will also be reduced.

3. ALWAYS keep winch maintained in accordance with this instruction sheet. **REMEMBER:** Worn parts cause unsafe conditions.
4. Winch components can be affected by chemicals, salts and rust and should be examined for unsafe conditions before operating.
5. NEVER alter the mechanics of the winch (Example: do not add to the handle length to make easier lifting).
6. NEVER use two or more winch units to lift a load that is greater than the load rating of any single unit. A shifting load may place the entire load on one unit, causing sudden failure of equipment, property damage and serious injury.
7. Apply the load evenly. Do not jerk or bounce the load or allow the load to swing. Avoid violent motion and shock loads. This type of operation requires equipment with higher load ratings.
8. Each time a load is to be lifted, test winch for safe operation by lifting the load a few inches first.
9. ALWAYS keep hands away from load-bearing cables, ropes, sheaves, drums and pulleys while operating.

REMAIN CONSTANTLY AWARE THAT SAFE OPERATING IS YOUR RESPONSIBILITY.

LIMITED WARRANTY

Shelby Industries, Division of Prospects Boat Works, Incorporated warrants its products described herein to be free from defects in material and workmanship to the original purchaser at the date of purchase at retail. If any of these products is found to be defective, it may be replaced or repaired, at the option of Shelby, when returned with proof of purchase to Shelby's manufacturing facility in Shelbyville, Kentucky. The owner shall pay all transportation and shipping charges associated with the return of said product and the returned product shall become the property of Shelby. Where Shelby determines that circumstances are such as to preclude the remedying of warranted defects by replacements or repair, Shelby shall, upon return of the products and proof of purchase, refund owner's purchase price.

In no instance shall Shelby be responsible to repair or replace a product under this limited warranty where said product was improperly installed, altered or misused, including using the product contrary to Shelby's printed instructions or instructions stamped on the product itself.

The foregoing states the sole and exclusive remedy for any breach of warranty or for any other claim based on any defect in or non-performance of, the products, whether sounding in contract, warranty or negligence or strict liability. Shelby makes no other warranties express or implied, hereby excludes any implied warranties of mechanability or fitness.

Without limiting the generality of the foregoing, Shelby shall under no circumstances be liable for any incidental or consequential loss or damage whatsoever arising out of, or in any way relating to, any such breach of warranty or claimed defect in, or non-performance of, the products.

This limited warranty is designed to fully comply with the terms and provisions of the Magnuson-Moss Warranty Act. Some states may not allow the limitation of exclusion of incidental or consequential damages, so the above limitations or exclusions may not apply to you.

For more information or assistance regarding this product, contact your dealer or write to: Customer Service Manager, Shelby Industries, Division Boat Works, P.O. Box 308, Shelbyville, Kentucky 40065.

NOTE: THIS PRODUCT COMPLIES WITH REGULATION V-5 AND C.S.A. STANDARD D-264.

NOTE: SOME STATES REQUIRE CLEAR VIEW OF LICENCE. REMOVE BALL WHEN NOT IN USE IF IT RESTRICTS VIEW.

NOTE: THIS PRODUCT COMPLIES WITH SAFETY SPECIFICATION & REQUIREMENTS FOR CONNECTING DEVICES & TOWING SYSTEMS OF THE STATE OF NEW YORK.