

Product Dimension



Front



Side

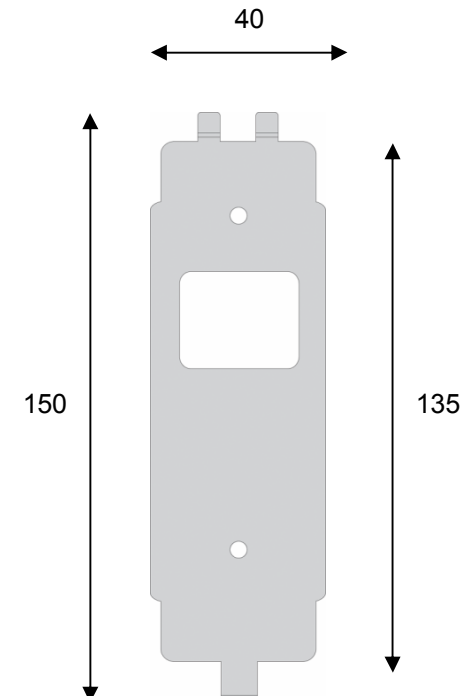

Metal Bracket

(unit : mm)

Cables and Connectors

Power and RS485

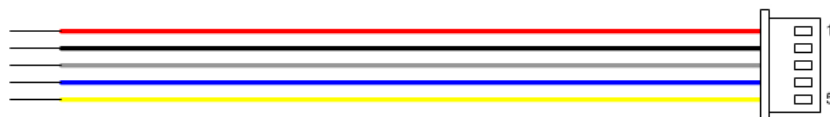

PIN	PIN DESCRIPTION	WIRE
1	POWER +12V	RED
2	POWER GND	BLACK
3	RS -485 GND	GRAY
4	RS -485 TRX+	BLUE
5	RS -485 TRX-	YELLOW

TCP/IP



PIN	PIN DESCRIPTION	WIRE	RJ45 PIN
1	TX +	YELLOW	6
2	TX -	GREEN	3
3	RX +	RED	2
4	RX -	BLACK	1

Wiegand output



PIN	PIN DESCRIPTION	WIRE
1	WIEGAND DATA0	GREEN
2	WIEGAND DATA1	WHITE
3	WIEGAND GND	BLACK

Digital Inputs and Relay output

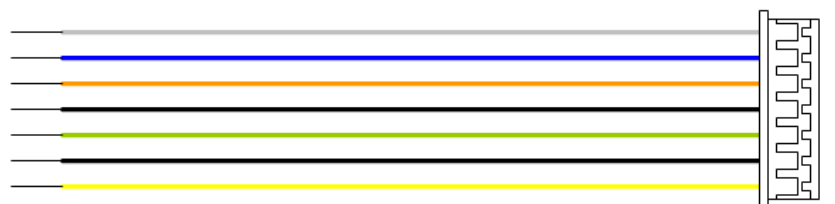

PIN	PIN DESCRIPTION	WIRE
1	SW1 INPUT	YELLOW
2	SW1 GND	BLACK
3	SW2 INPUT	GREEN
4	SW2 GND	BLACK
5	RELAY NORMAL CLOSE	ORANGE
6	RELAY COMMON	BLUE
7	RELAY NORMAL OPEN	WHITE

Installation of Wall-mount Bracket

- Fix wall mount bracket on a wall using wall mounting screws

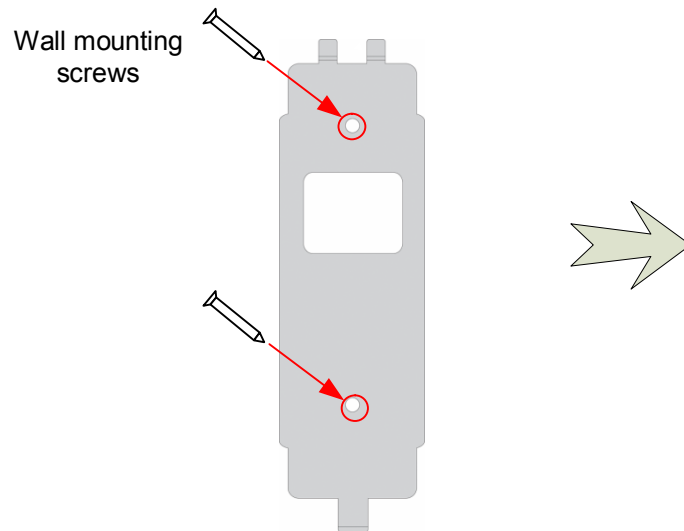

- Hook BioEntry Plus on the wall mount bracket

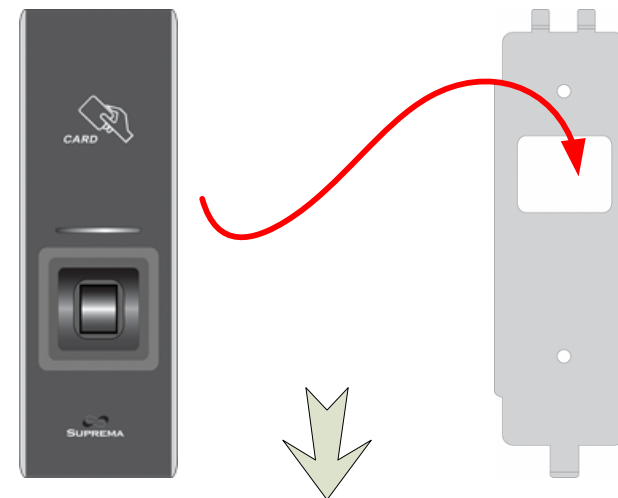

- Fix BioStation and wall mounting bracket using a star shape screw.

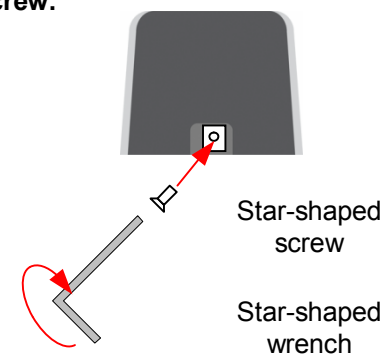

Power Connection

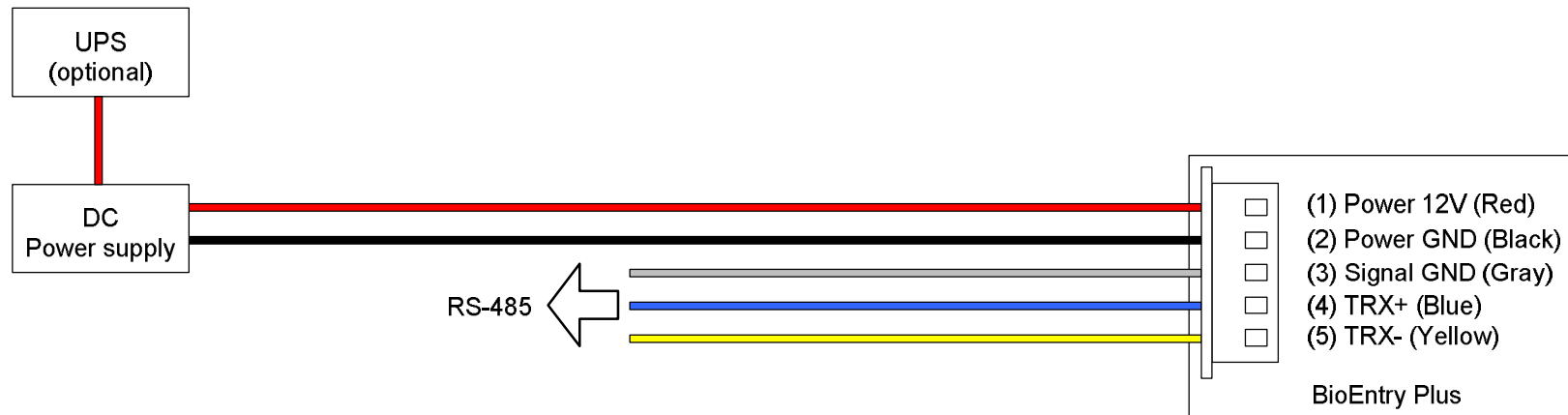

- **Recommended power supply**
 - 12V \pm 10%, at least 1500mA.
 - Comply with standard IEC/EN 60950-1.
 - To share the power with other devices, use a power supply with higher current ratings.

Ethernet Connection

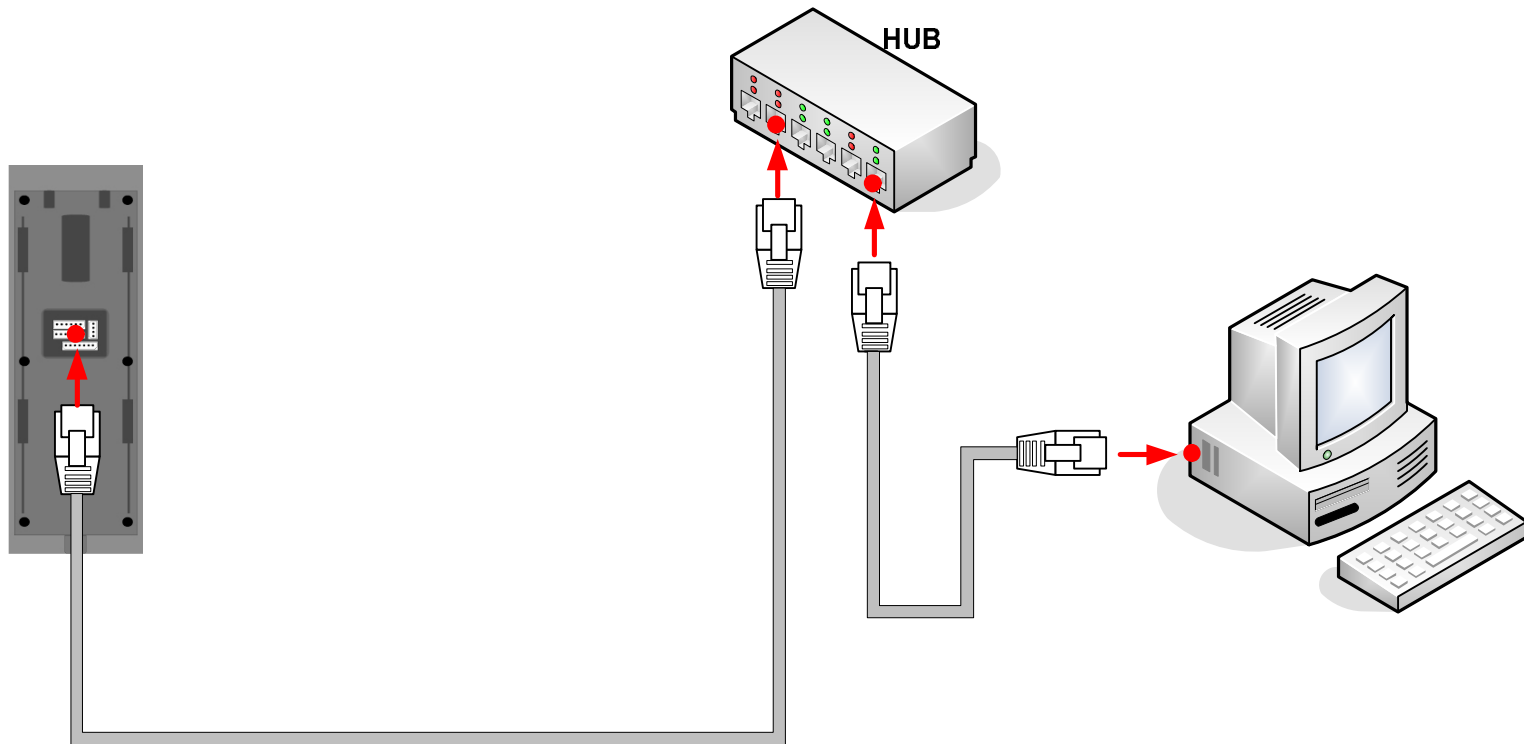

Ethernet Connection (Direct connection with PC)

- To connect BioEntry Plus with a PC directly, connect both devices with a straight CAT-5 cable. As the BioEntry Plus supports auto MDI/MDIX feature, it is not necessary to use a crossover type cable.

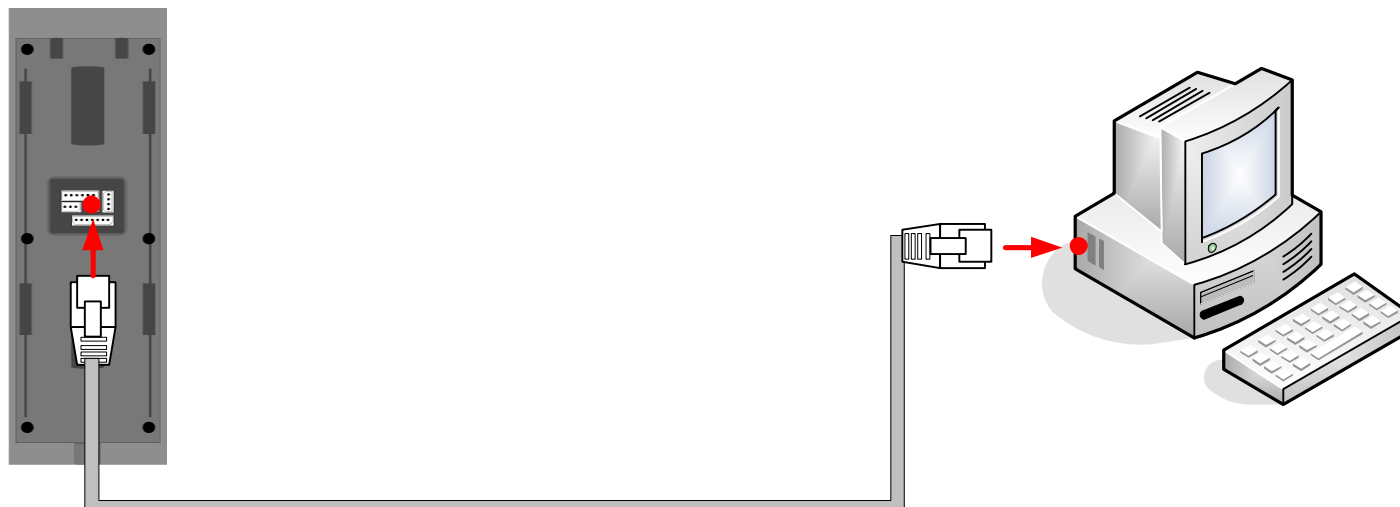

RS485 Connection for Host Communication

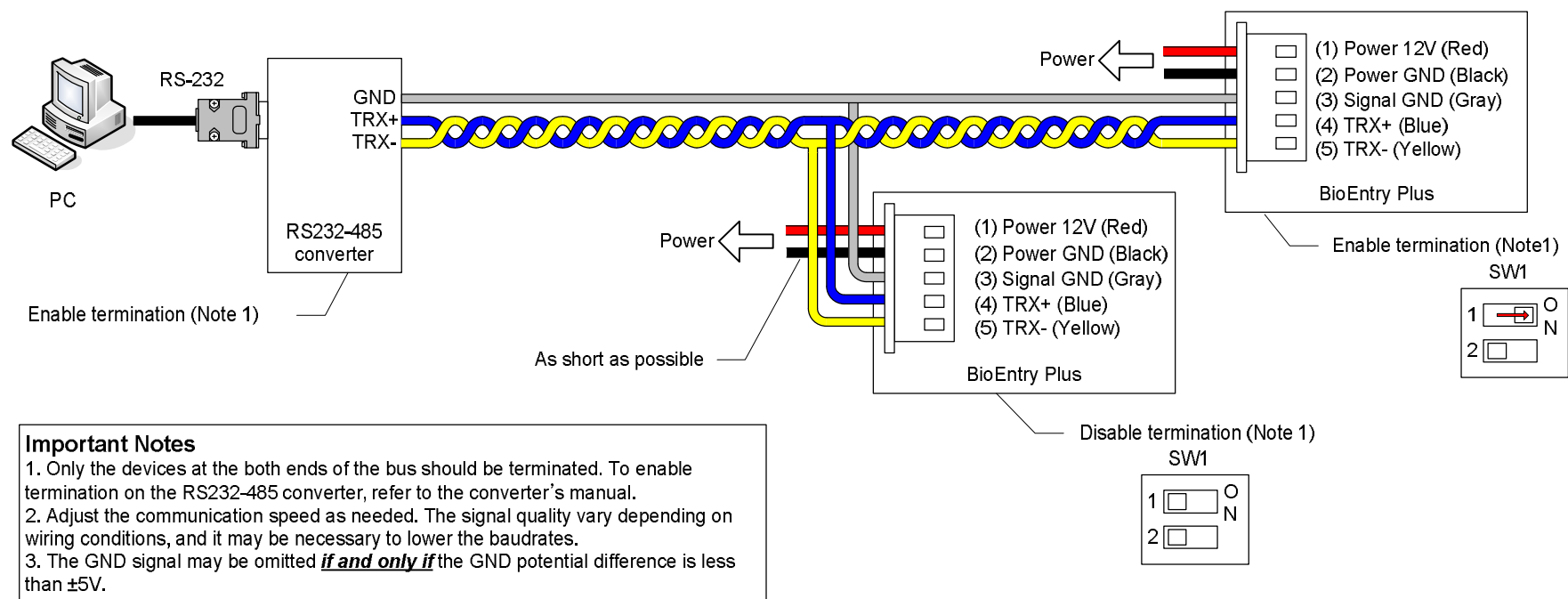

RS485 Connection for Secure I/O

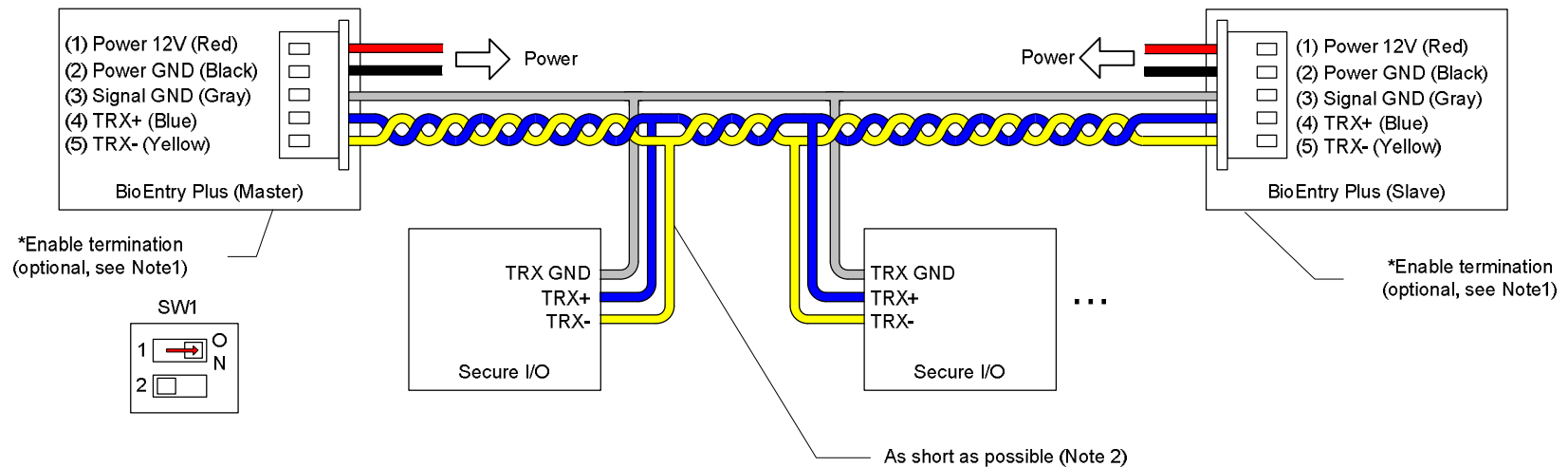

Important Notes

1. For bus termination, only the devices at both ends of the bus should be terminated. To enable termination on the RS232-485 converter, refer to the converter's manual.
2. The stubs should be as short as practical

■ Max number of devices

- Maximum numbers of devices in an RS485 loop are two(2) devices (BioStation or BioEntry Plus) and four(4) Secure I/Os

Relay Connection – Fail safe lock

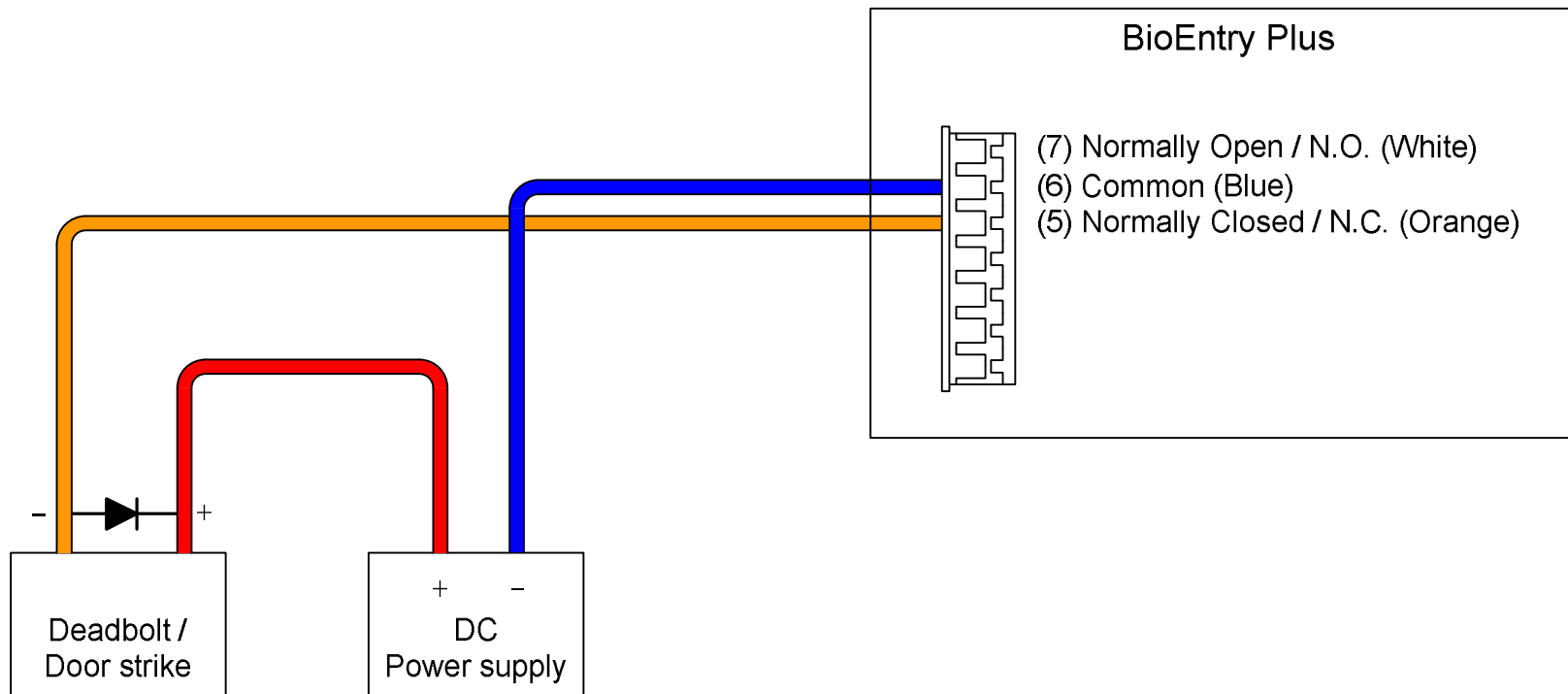

Relay Connection – Fail secure lock

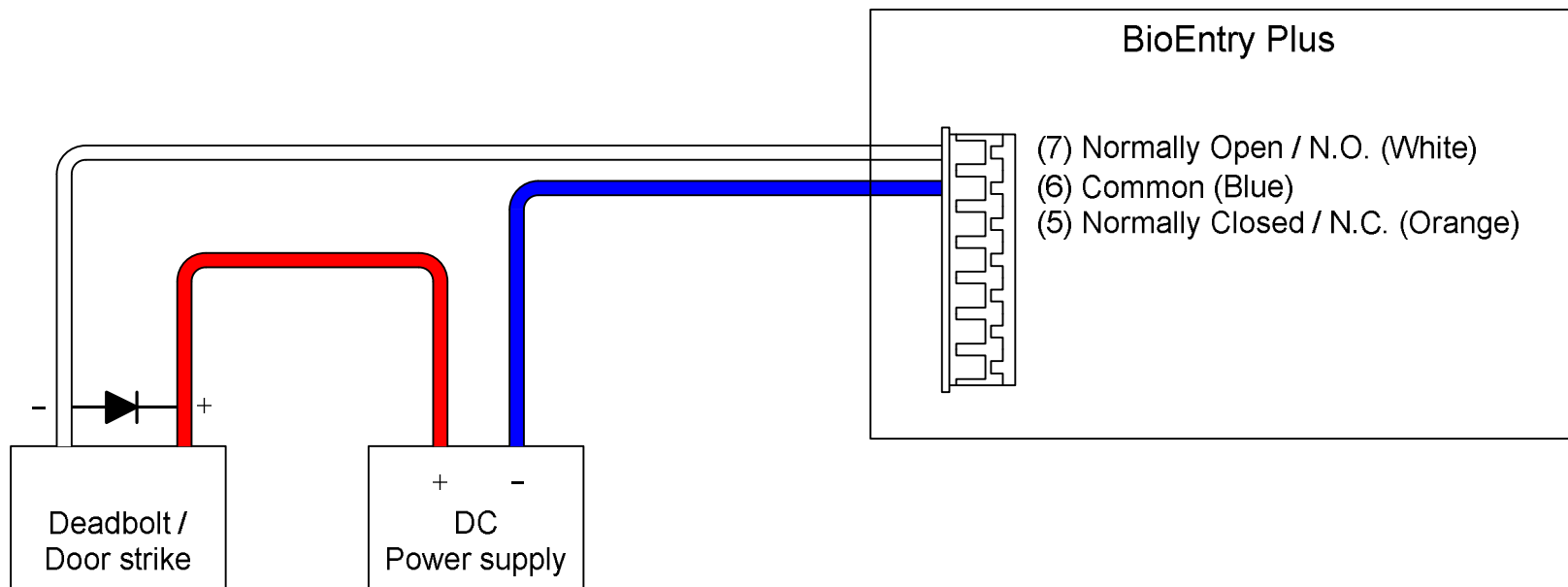

Relay Connection - Automatic door

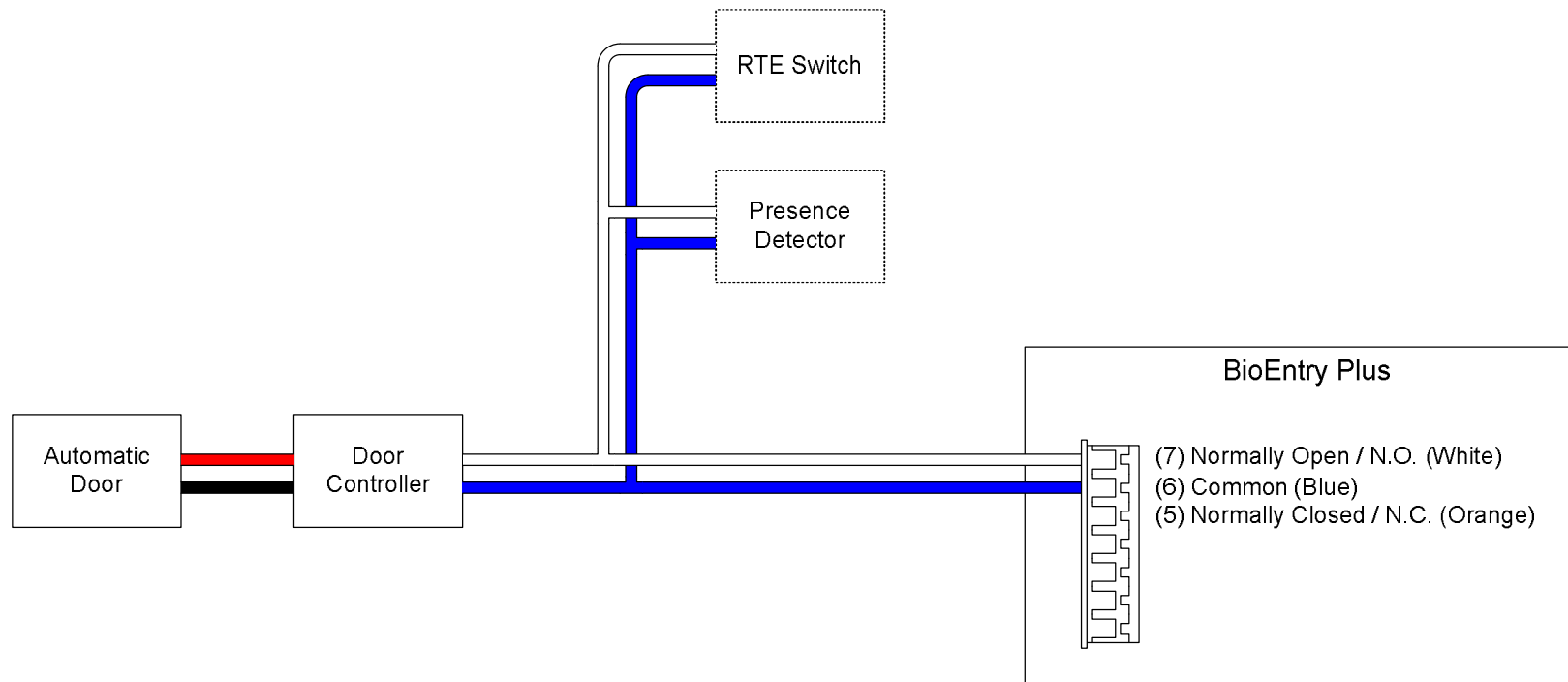

Digital Input Connection (RTE, Door sensor)

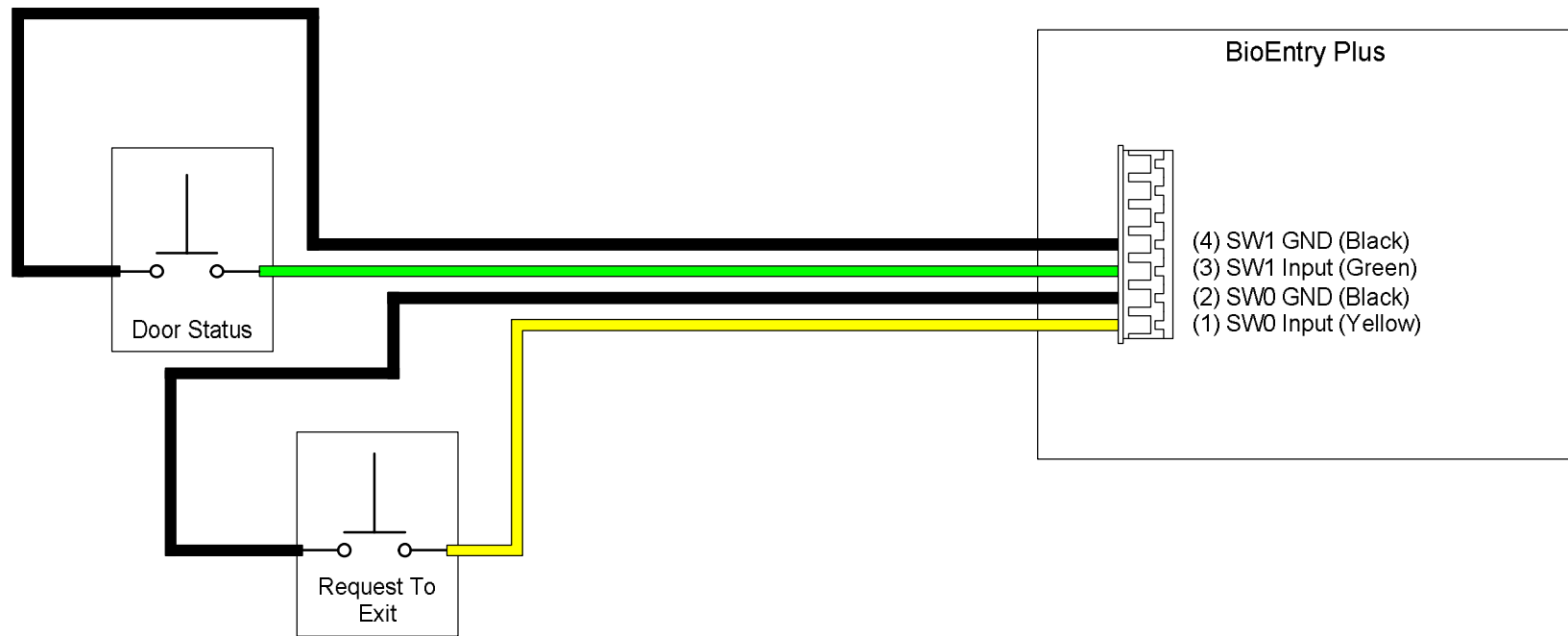

Digital Input Connection (Alarm, Emergency sw)

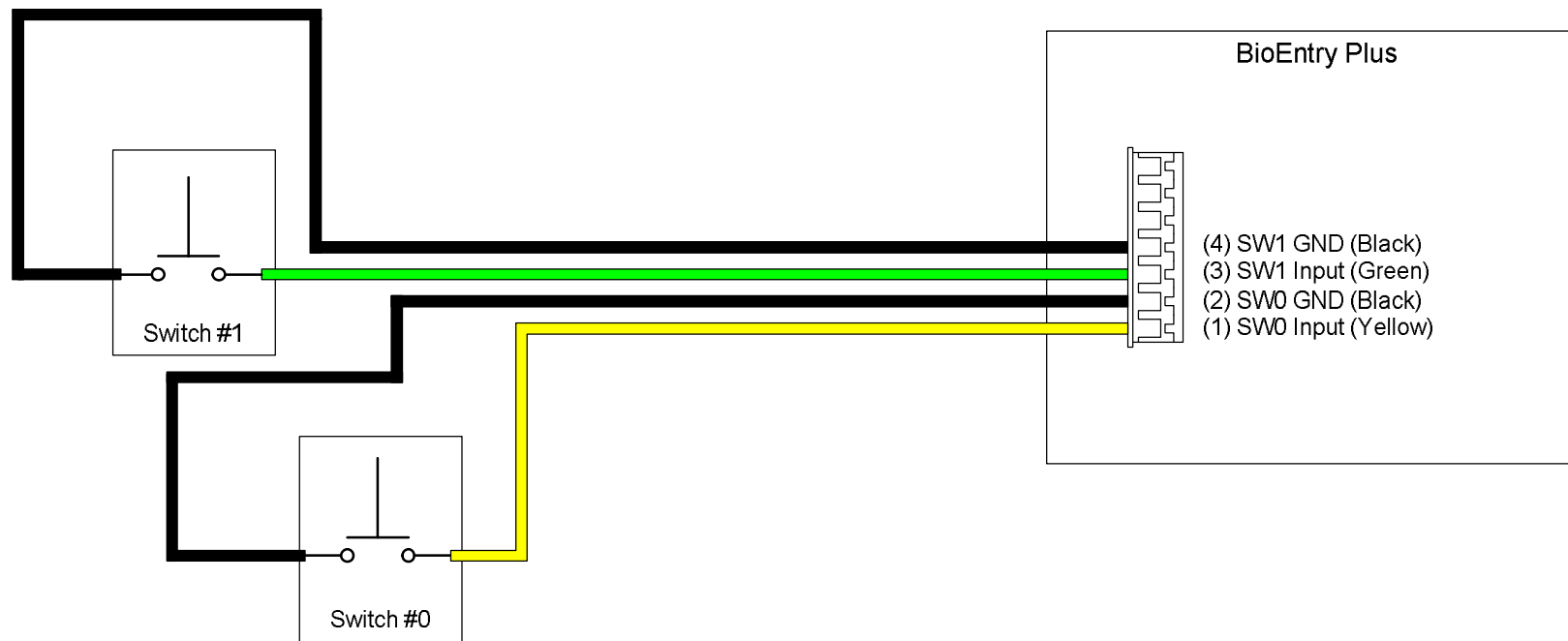

Wiegand Output

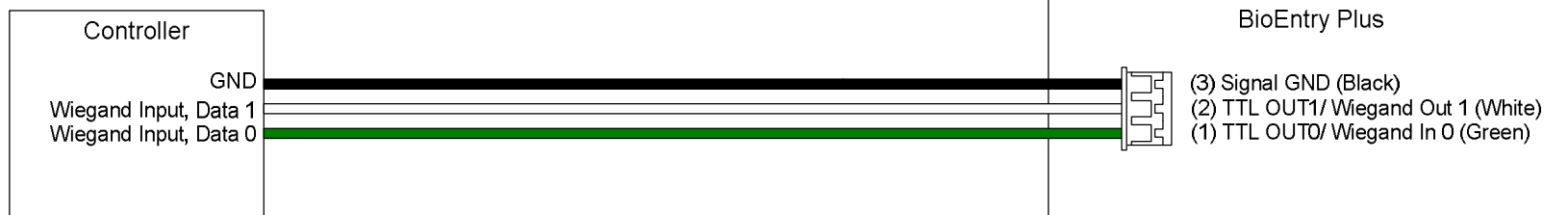

Installation Reference 1 - Stand alone

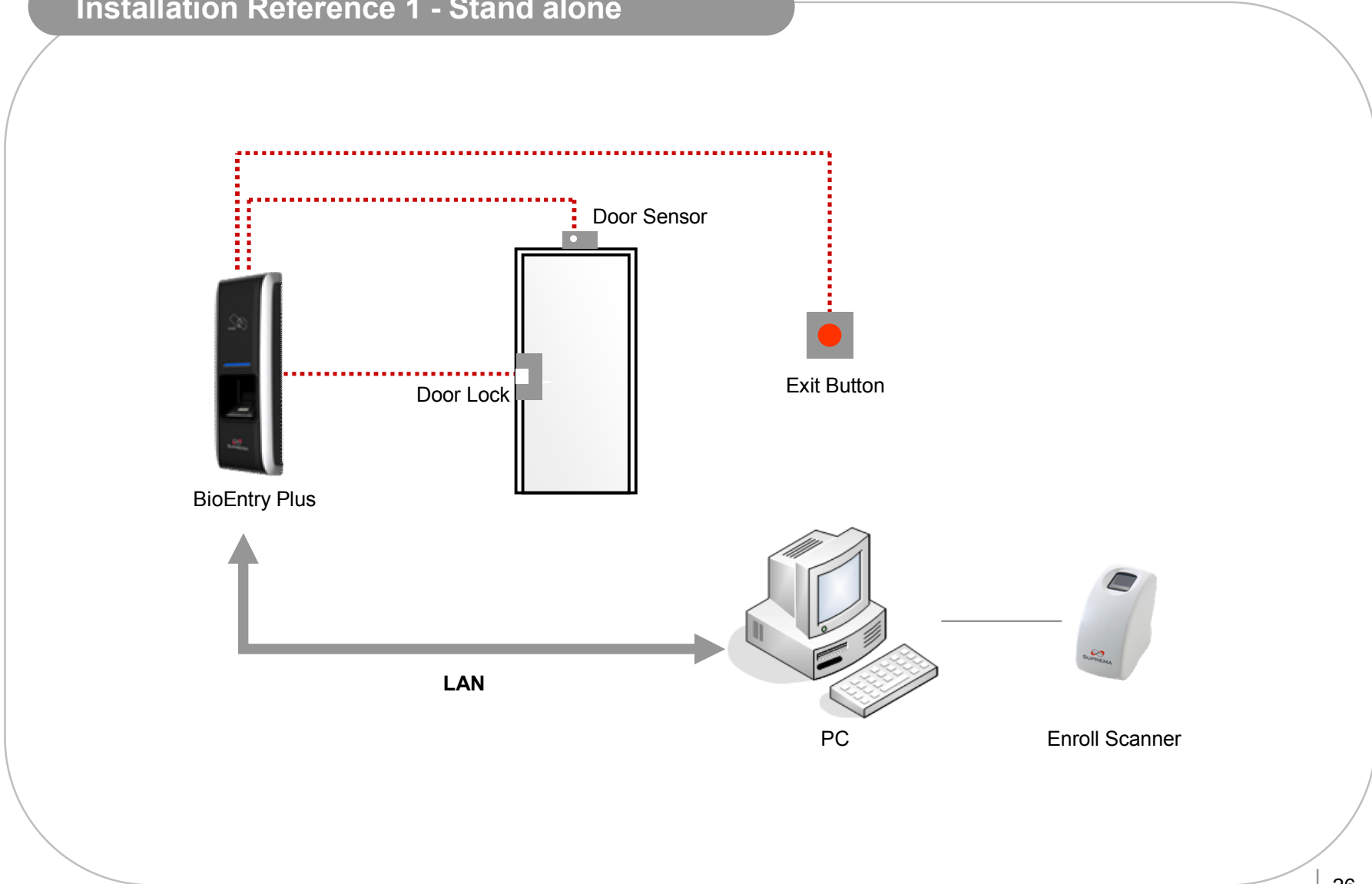

Installation Reference 2 – Secure

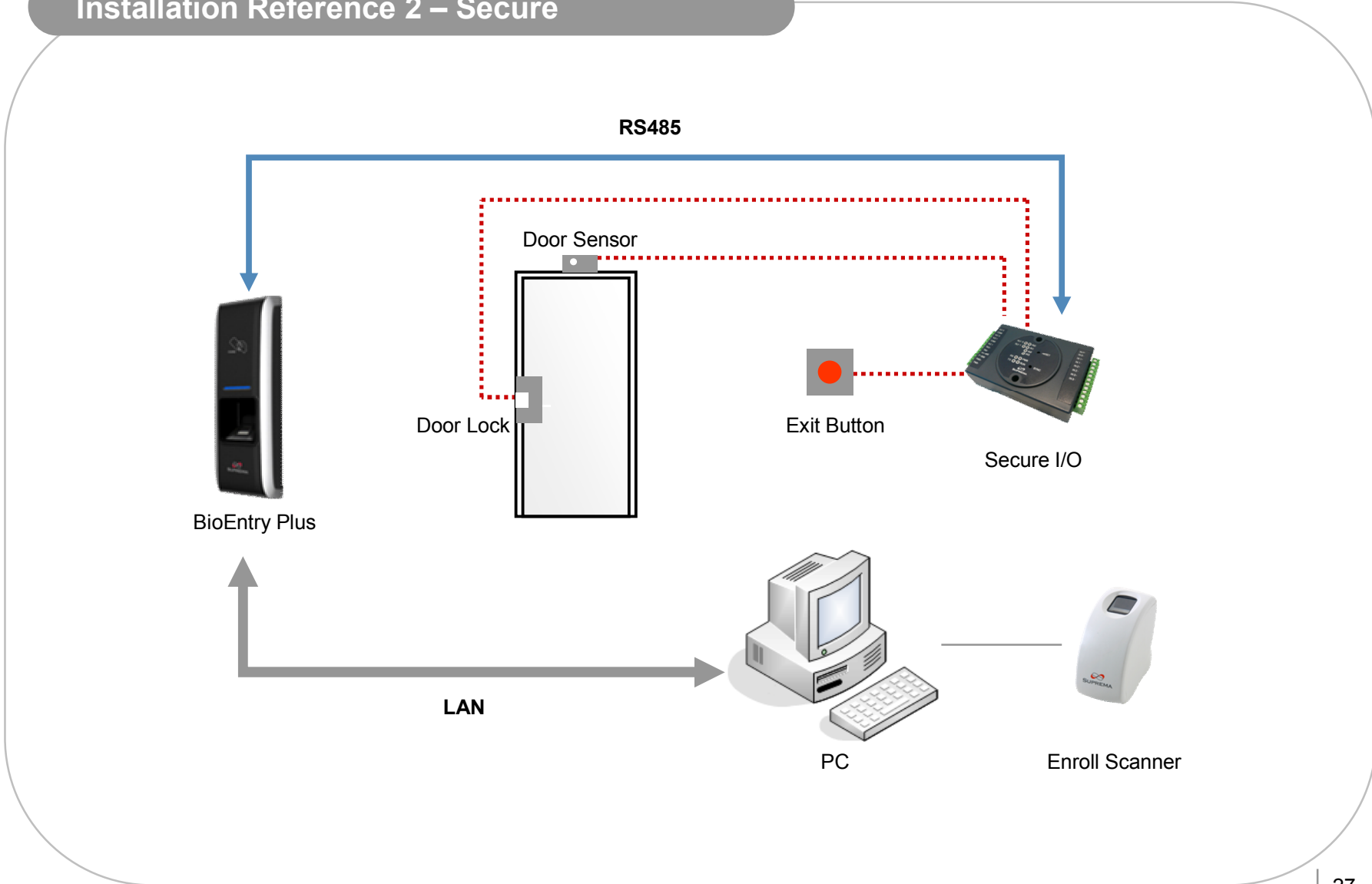

Installation Reference 3 – Network

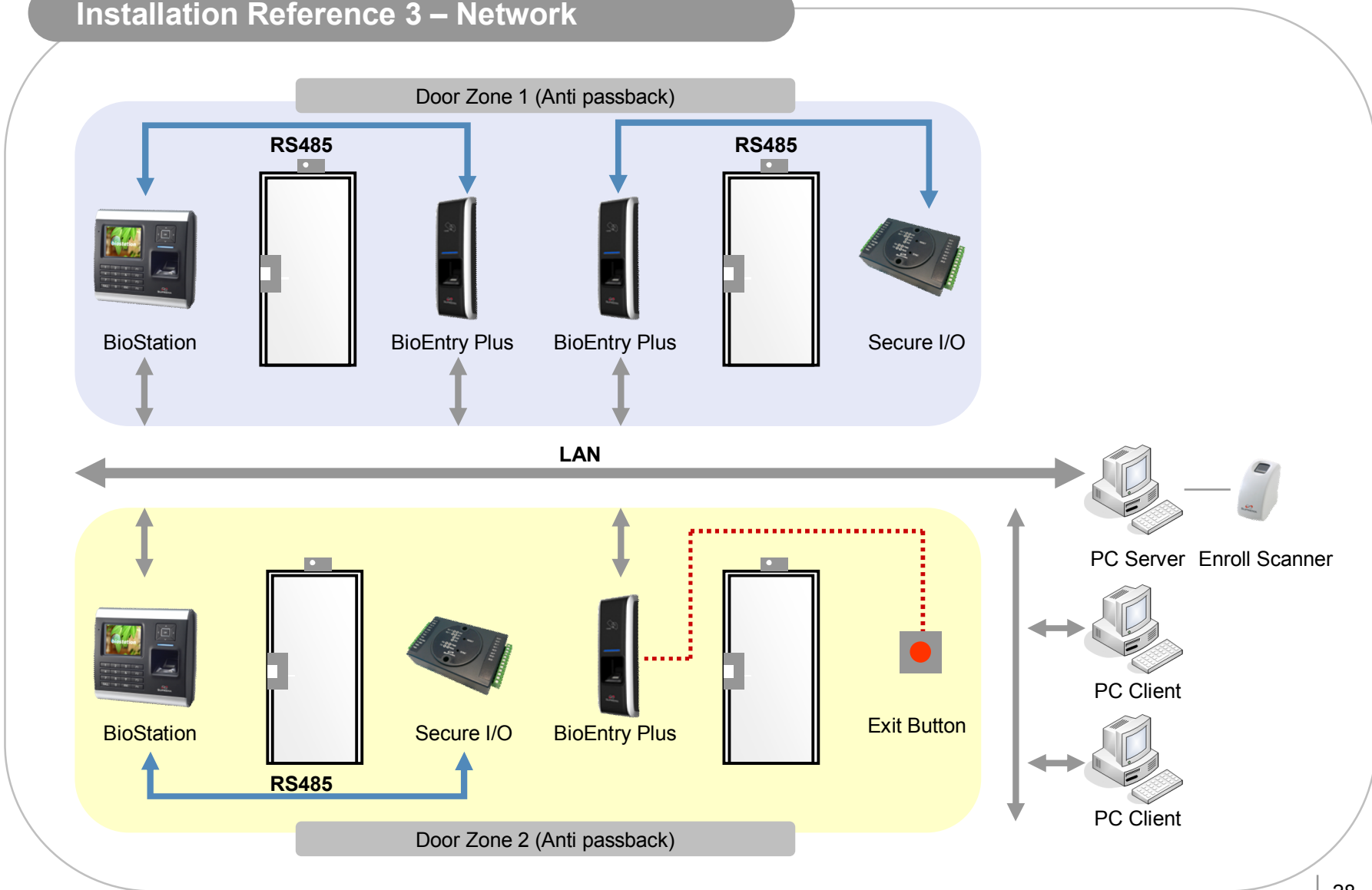

Electrical Specification

	Min.	Typ.	Max.	Notes
Power				
Voltage (V)	10.8	12	13.2	Use regulated DC power adaptor only
Current (mA)	-		250	
Switch Input				
V _{IH} (V)	-	TBD	-	
V _{IL} (V)	-	TBD		
Pull-up resistance (Ω)	-	4.7k	-	The input ports are pulled up with 4.7k resistors
TTL/Wiegand Output				
V _{OH} (V)	-	5	-	
V _{OL} (V)	-	0.8	-	
Pull-up resistance (Ω)	-	4.7k	-	The outputs ports are open drain type, pulled up with 4.7k resistors internally
Relay				
Switching capacity (A)	-	-	1 0.3	30V DC 125V AC
Switching power (resistive)	-	-	30W 37.5VA	DC AC
Switching voltage (V)	-	-	110 125	DC AC

Troubleshooting

- **Fingerprint can not be read well or it takes too long.**
 - Check whether a finger or fingerprint sensor is stained with sweat, water, or dust
 - Retry after wiping off finger and fingerprint sensor with dry towel.
 - If a fingerprint is way too dry, blow on the finger and retry.
- **Fingerprint is entered but authorization keeps failing.**
 - Check whether the user is restricted by door zone or time zone.
 - Inquire of administrator whether the enrolled fingerprint has been deleted from the device for some reason.
- **Authorized but door is not opened.**
 - Check whether the time is set as lock time.
 - Check whether an antipass back mode is in use. In antipass back mode, only who entered can exit.
- **Device doesn't operate though power is connected.**
 - Check whether a device and a bracket is well connected to each other. If not, a tamper switch is activated and the device doesn't work.

Device cleaning

- Wipe out machine surface with dry towel or cloth.
- In case there is dust or impurities on the sensor of the BioStation, wipe off the surface with dry towel.
- Note that if the sensor is cleaned by detergent, benzene or thinner, surface is damaged and fingerprint can't be entered.

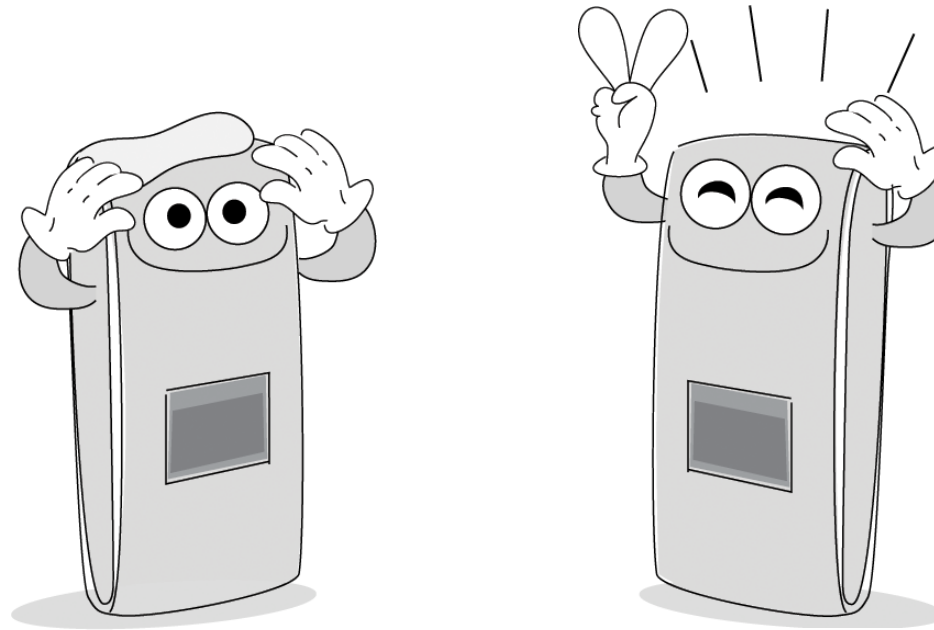

FCC Rules

Caution

- Changes or modifications not expressly approved by the manufacturer responsible for compliance could void the user's authority to operate the equipment.

Warning

- This device complies with part 15 of the FCC Rules. Operation is subject to the following two conditions: (1) This device may not cause harmful interference, and (2) this device must accept any interference received, including interference that may cause undesired operation.

Information to User

- This equipment has been tested and found to comply with the limit of a Class B digital device, pursuant to Part 15 of the FCC Rules. These limits are designed to provide reasonable protection against harmful interference in a residential installation. This equipment generates, user and can radiate radio frequency energy and, if not installed and used in accordance with the instructions, may cause harmful interference to radio communications. However, there is no guarantee that interference will not occur in a particular installation; if this equipment does cause harmful interference to radio or television reception, which can be determined by turning the equipment off and on, the user is encouraged to try to correct the interference by one or more of the following measures:
 1. Reorient / Relocate the receiving antenna.
 2. Increase the separation between the equipment and receiver.
 3. Connect the equipment into an outlet on a circuit different from that to which the receiver is connected.
 4. Consult the dealer or an experienced radio/TV technician for help

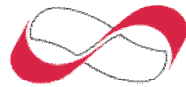

SUPREMA

Suprema Inc.

16F Parkview Office Tower, Jeongja-dong, Bundang-gu,

Seongnam, Gyeonggi, 463-863 Korea

E-mail : support@supremainc.com

Website : www.supremainc.com

Functions and specifications of the product are subject to changes without notice due to quality enhancement or function update. For any inquiry on the product, please contact **Suprema Inc.**