



www.supremainc.com



BioLite solo

Innovative Fingerprint Terminal

User guide(ver 1.0)

CAUTION: Changes or modifications not expressly approved by the manufacturer responsible for compliance could void the user's authority to operate the equipment

WARNING

This device complies with part 15 of the FCC Rules. Operation is subject to the following two conditions: (1) This device may not cause harmful interference, and (2) this device must accept any interference received, including interference that may cause undesired operation.

INFORMATION TO USER:

This equipment has been tested and found to comply with the limit of a Class B digital device, pursuant to Part 15 of the FCC Rules. These limits are designed to provide reasonable protection against harmful interference in a residential installation. This equipment generates, uses and can radiate radio frequency energy and, if not installed and used in accordance with the instructions, may cause harmful interference to radio communications. However, there is no guarantee that interference will not occur in a particular installation; if this equipment does cause harmful interference to radio or television reception, which can be determined by turning the equipment off and on, the user is encouraged to try to correct the interference by one or more of the following measures:

1. Reorient / Relocate the receiving antenna.
2. Increase the separation between the equipment and receiver.
3. Connect the equipment into an outlet on a circuit different from that to which the receiver is connected.
4. Consult the dealer or an experienced radio/TV technician for help

Product Contents

- Basic Contents



Main Body



Default



Sub bracket
(optional)



Wall mounting screws – 2 ea



Star-shaped screws
E-ring



Star-shaped small wrench

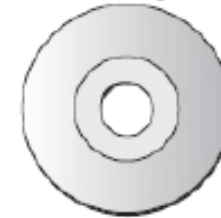

Software CD

Wall-mounting metal bracket

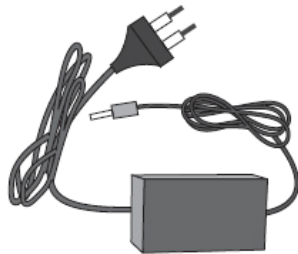

12V power adaptor
(optional)



Shrinking Tube

Cable spec.

Power & 485

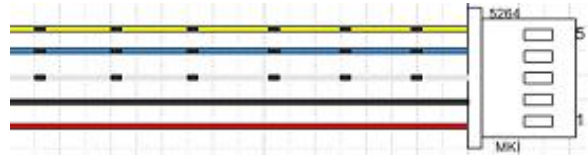

| PIN | POWER + 485 | WIRE |
|-----|-----------------|----------------------|
| 1 | POWER + (12Vdc) | RED |
| 2 | POWER GND | BLACK |
| 3 | 485 GND | WHITE(Black String) |
| 4 | 485 + | BLUE(Black String) |
| 5 | 485 - | YELLOW(Black String) |

Relay

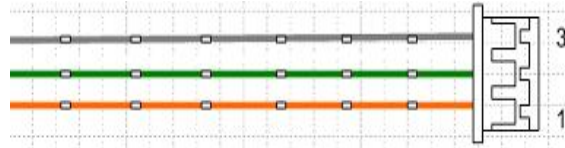

| PIN | RELAY | WIRE |
|-----|--------------|----------------------|
| 1 | NORMAL CLOSE | ORANGE(White String) |
| 2 | COMMON | GREEN(White String) |
| 3 | NORMAL OPEN | GRAY(White String) |

Switch

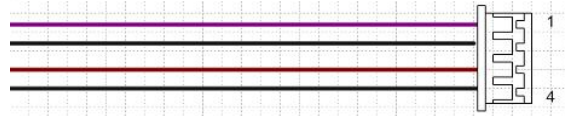

| PIN | SWITCH | WIRE |
|-----|--------|--------|
| 1 | SWIN 0 | PURPLE |
| 2 | GND | BLACK |
| 3 | SWIN 1 | Brown |
| 4 | GND | BLACK |

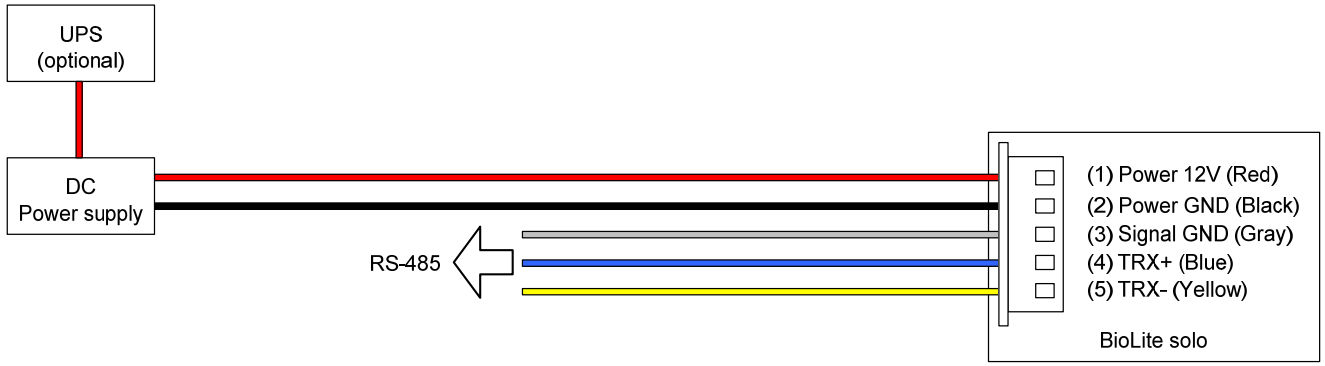

- **Recommended power supply**
 - 12V ± 10%, at least 1000mA.
 - To share the power with other devices, use a power supply with higher current ratings.

Relay Connection – Fail safe lock

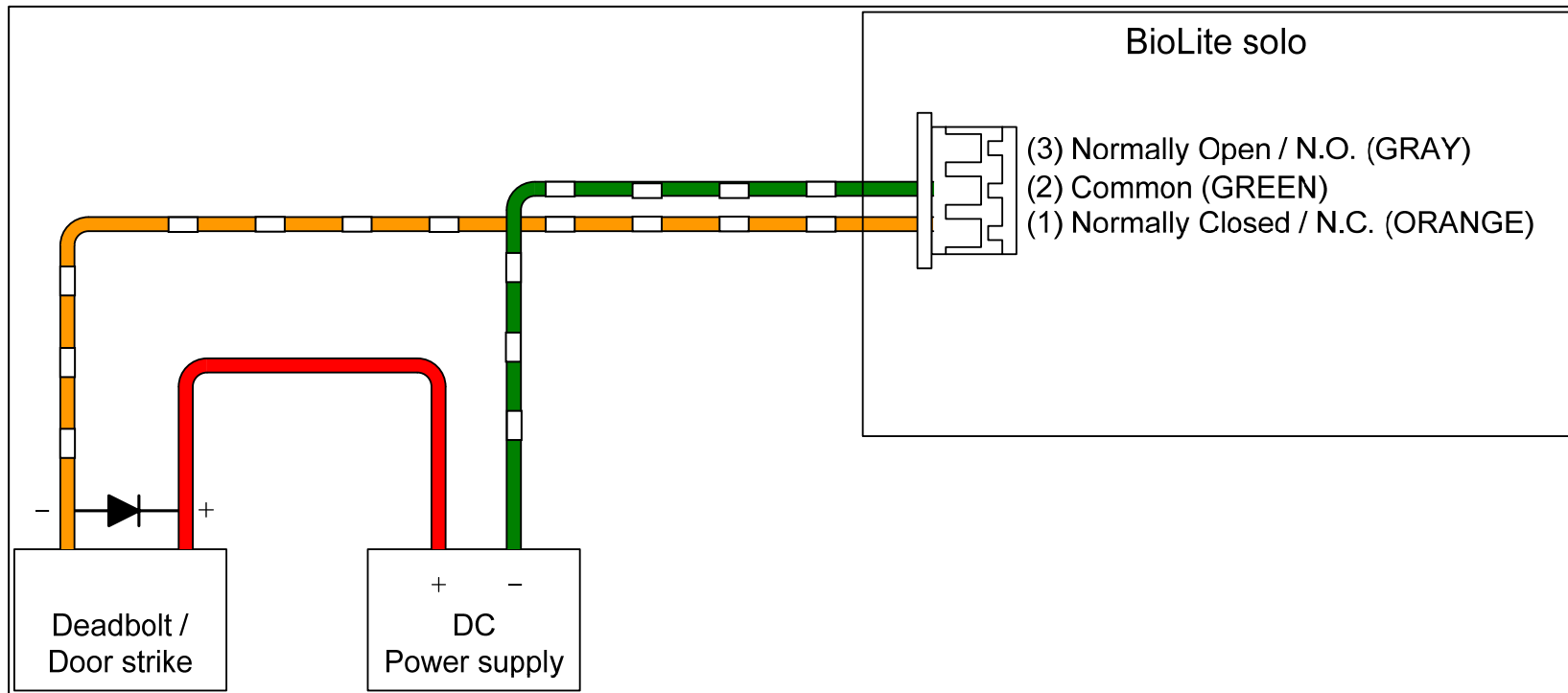

Relay Connection – Fail secure lock

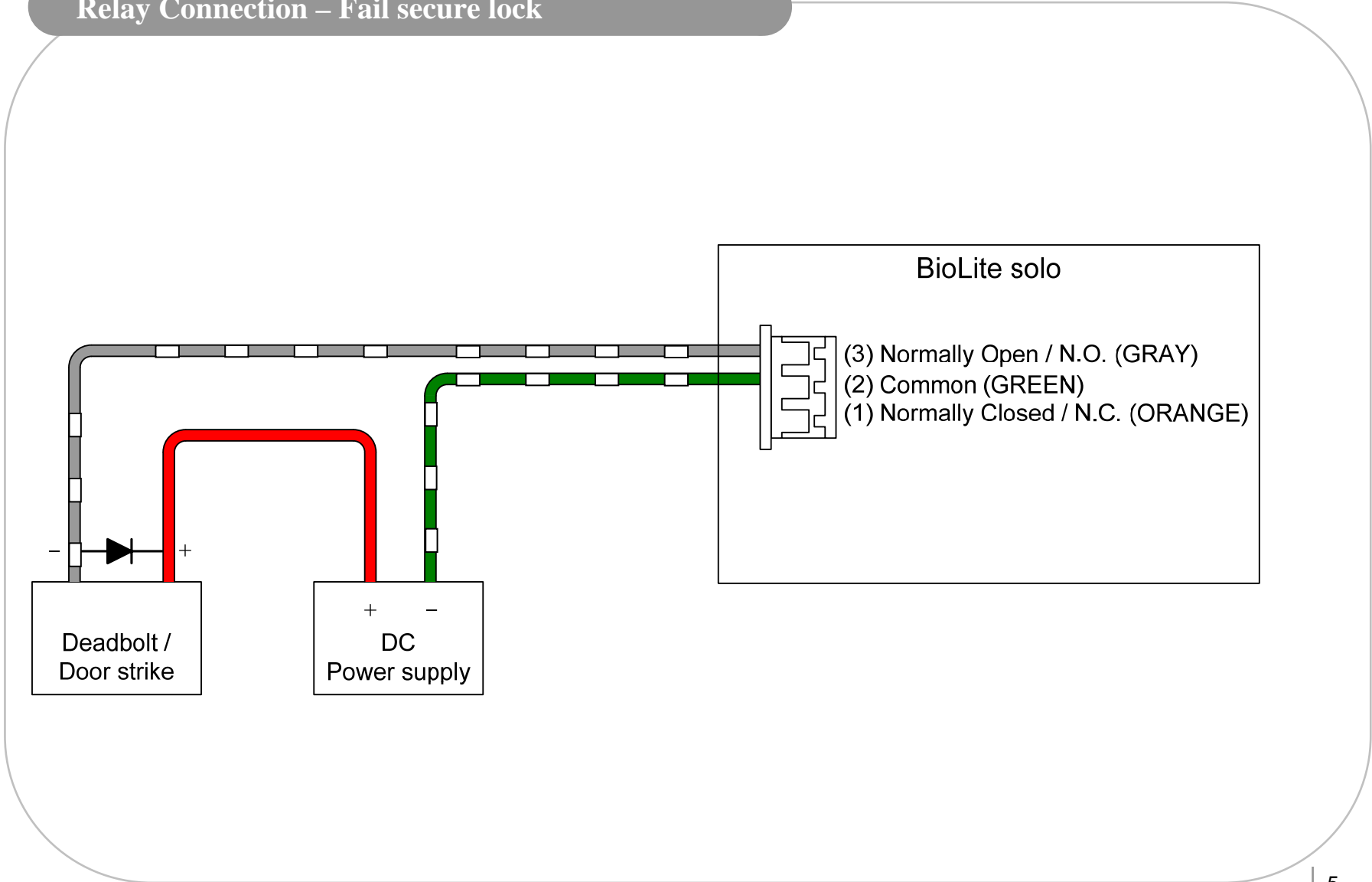

Relay Connection - Automatic door

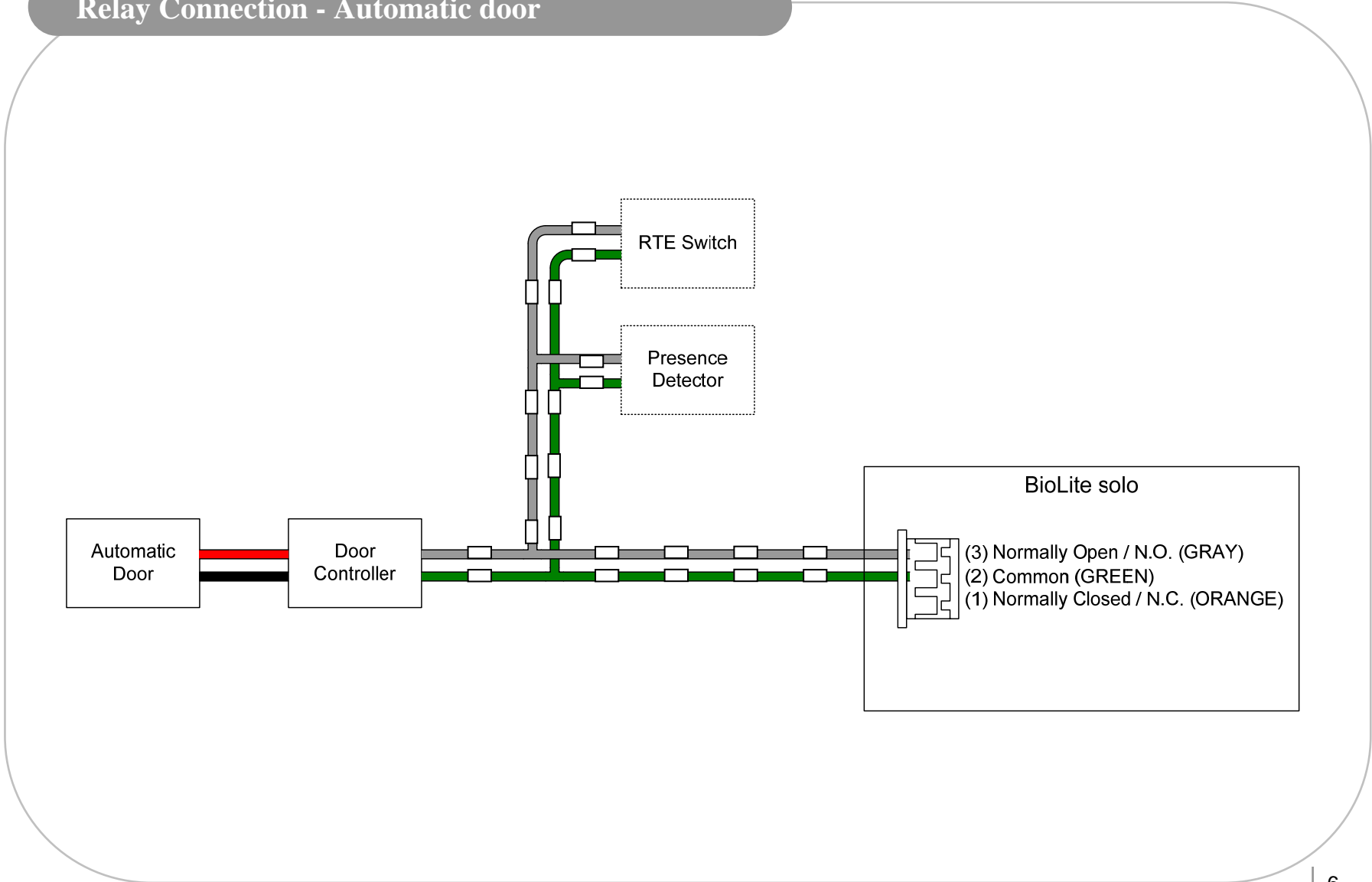

Door switch connection

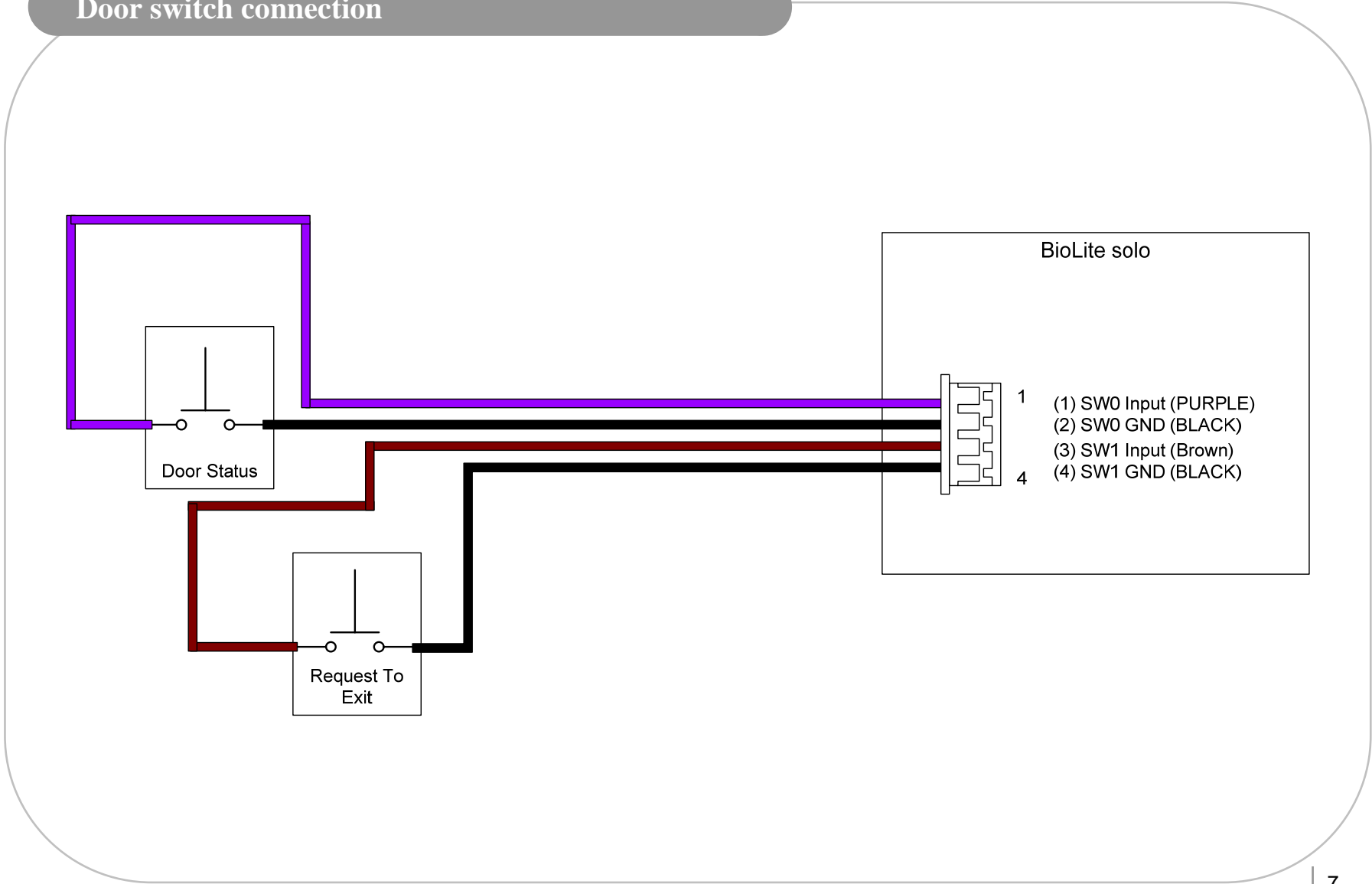

Switch connection (Alarm, Emergency switches)

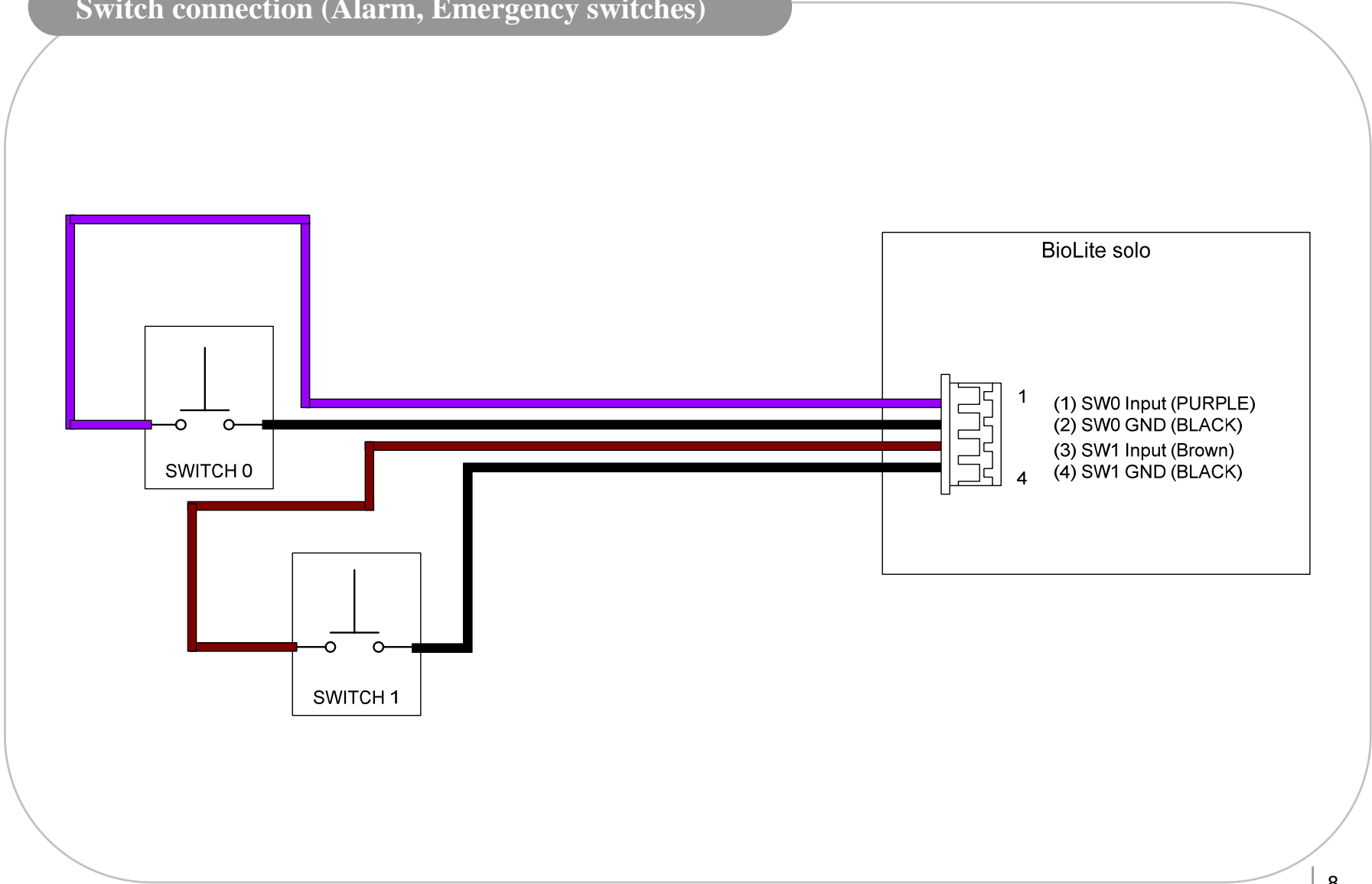

RS485 connection for host communication

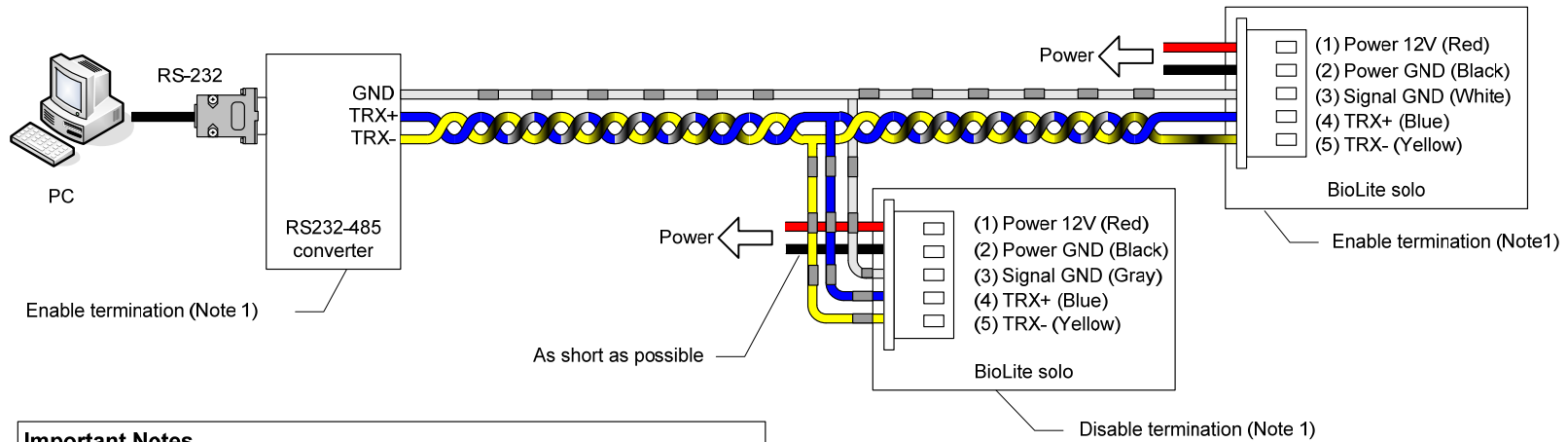

Important Notes

1. Only the devices at the both ends of the bus should be terminated. To enable termination on the RS232-485 converter, refer to the converter's manual.
2. Adjust the communication speed as needed. The signal quality vary depending on wiring conditions, and it may be necessary to lower the baudrates.
3. The GND signal may be omitted **if and only if** the GND potential difference is less than $\pm 5V$.

RS485 connection for Secure I/O

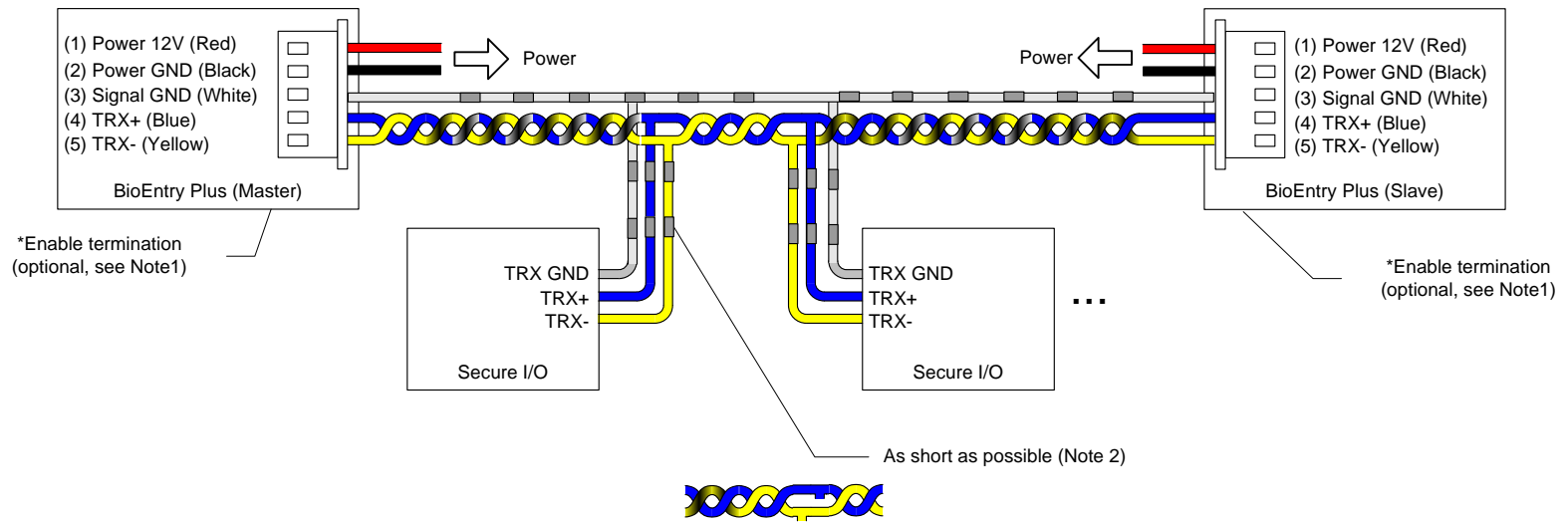

Important Notes

1. For bus termination, only the devices at both ends of the bus should be terminated. To enable termination on the RS232-485 converter, refer to the converter's manual.
2. The stubs should be as short as practical

Installation of Wall-mount Bracket

- Fix wall mount bracket on a wall using wall mounting screws

Wall mounting screws

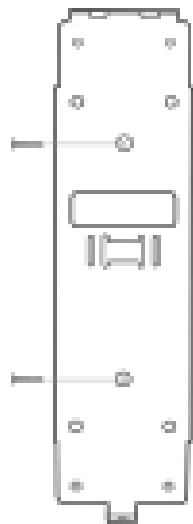

- Hook BioEntry Plus on the wall mount bracket

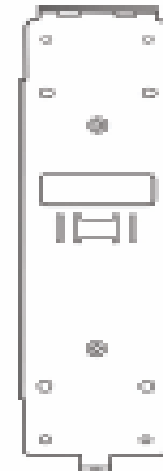
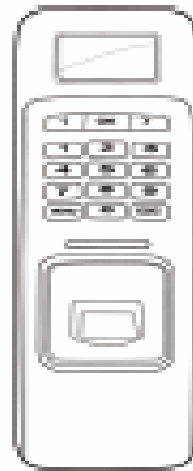

- Fix BioLite Solo and wall mounting bracket using a star shape screw.

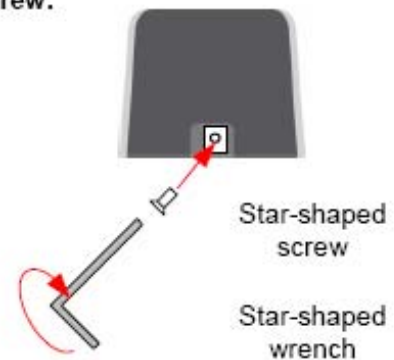

Installation Reference - Stand alone

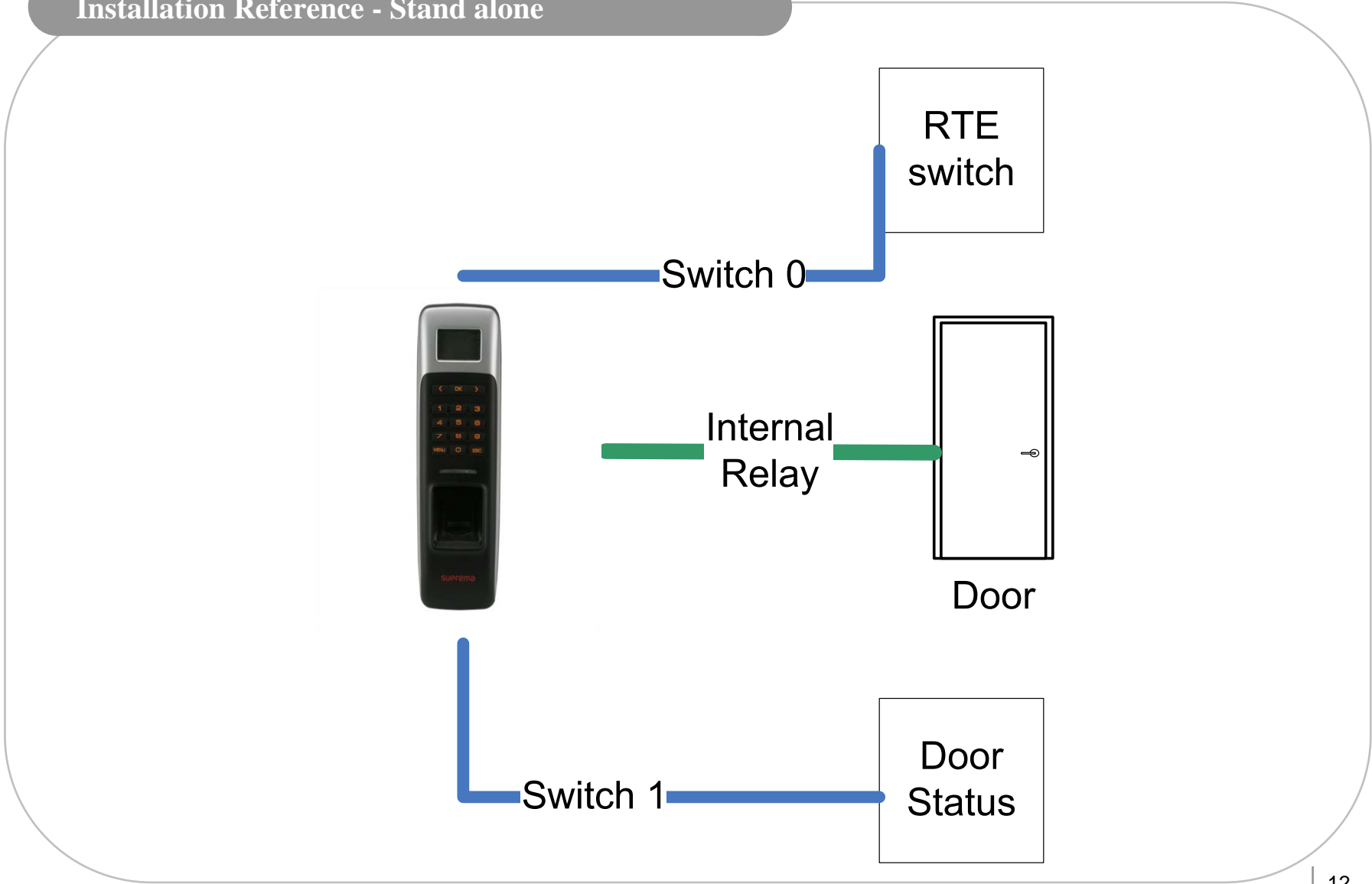

Installation Reference – Using Secure I/O, 2 door

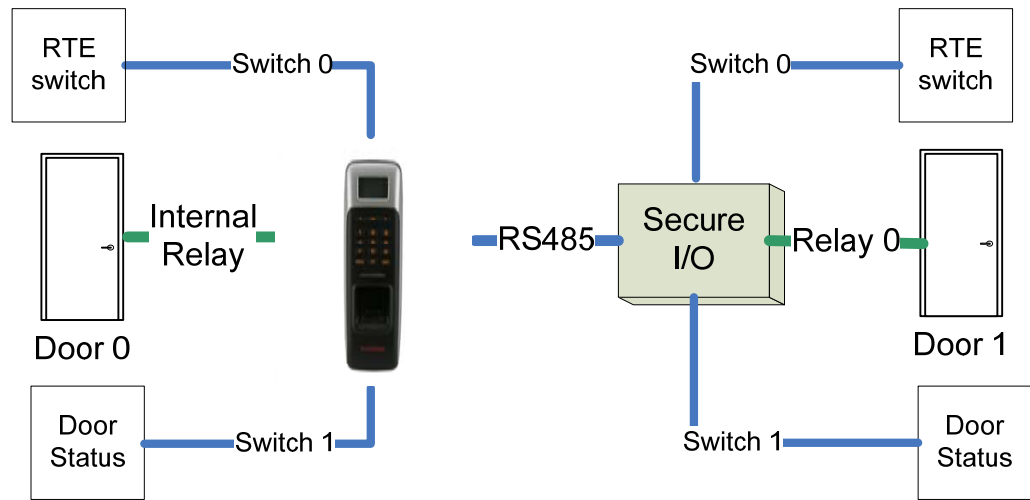

Electrical Specification

| | Min. | Typ. | Max. | Notes |
|-----------------------------|------|------|---------------|---|
| Power | | | | |
| Voltage (V) | 10.8 | 12 | 13.2 | Use regulated DC power adaptor only |
| Current (mA) | - | | 250 | |
| Switch Input | | | | |
| V _{IH} (V) | - | TBD | - | |
| V _{IL} (V) | - | TBD | | |
| Pull-up resistance (Ω) | - | 4.7k | - | The input ports are pulled up with 4.7k resistors |
| TTL/Wiegand Output | | | | |
| V _{OH} (V) | - | 5 | - | |
| V _{OL} (V) | - | 0.8 | - | |
| Pull-up resistance (Ω) | - | 4.7k | - | The outputs ports are open drain type, pulled up with 4.7k resistors internally |
| Relay | | | | |
| Switching capacity (A) | - | - | 1 0.3 | 30V DC 125V AC |
| Switching power (resistive) | - | - | 30W 37.5VA | DC AC |
| Switching voltage (V) | - | - | 110 125 | DC AC |

How to place a finger

Suprema's fingerprint products show an outstanding recognition performance regardless of the user's fingerprint skin condition or the way of fingerprint positioning. However, following tips are recommended to get more optimal fingerprint recognition performance.

■ Select a finger to enroll

- It is recommended to use an index finger or a middle finger.
- Thumb, ring or little finger is relatively more difficult to place in a correct position.



■ How to place a finger on a sensor

- Place a finger such that it completely covers the sensor area with maximum contact.
- Place core part of a fingerprint to the center of a sensor.
 - People tend to place upper part of a finger.
 - The core of a fingerprint is a center where the spiral of ridges is dense.
 - Usually core of fingerprint is the opposite side of the lower part of a nail.
 - Place a finger such that the bottom end of a nail is located at the center of a sensor.
- If a finger is placed as in the right picture, only a small area of a finger is captured. So it is recommended to place a finger as shown in the left picture.

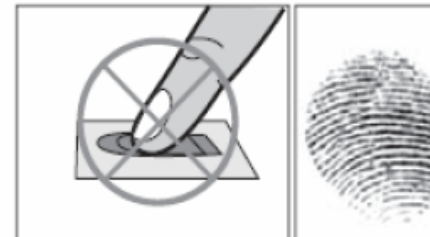

Troubleshooting

- **Fingerprint can not be read well or it takes too long.**
 - Check whether a finger or fingerprint sensor is stained with sweat, water, or dust
 - Retry after wiping off finger and fingerprint sensor with dry towel.
 - If a fingerprint is way too dry, blow on the finger and retry.
- **Fingerprint is entered but authorization keeps failing.**
 - Check whether the user is restricted by door zone or time zone.
 - Inquire of administrator whether the enrolled fingerprint has been deleted from the device for some reason.
- **Authorized but door is not opened.**
 - Check whether the time is set as lock time.
 - Check whether an antipass back mode is in use. In antipass back mode, only who entered can exit.
- **Device doesn't operate though power is connected.**
 - Check whether a device and a bracket is well connected to each other. If not, a tamper switch is activated and the device doesn't work.



Suprema Inc.
16F Parkview Office Tower, Jeongja-dong, Bundang-gu,
Seongnam, Gyeonggi, 463-863 Korea
E-mail : support@supremainc.com
Website : www.supremainc.com

Tel : 82-31-710-2400

Fax : 82-31-783-4506