

Spare parts list
(5.971-698.0) Spare parts list B 40 C Bp

DE HINWEISE

Weitere Sprachen:

Diese Ersatzteilliste ist in weiteren Sprachen erhältlich. Sie erhalten diese unter www.kaercher.com im Bereich Service.
Die Schreibweise der Teilenummer, z.B. 75456380, entspricht der Teilenummer 7.545-638.0.

Mengenangaben:

Die Mengenangaben in der Ersatzteilliste entsprechen den in der Baugruppe verbauten Stückzahlen der Bauteile.

Meterware:

Ersatzteile welche als Meterware geliefert werden sind auf Einbaulänge selbst zu kürzen. Die Stückzahlen sind als Mindestbestellmenge =1m angegeben und müssen je nach Bedarf auf weitere volle Meterzahlen erhöht werden.

Versionen/ Werknummern:

Sind Versionen oder Werknummern in der Ersatzteilliste angegeben, ist anhand dieser vor Bestellung zu prüfen, welches Bauteil für ihr Gerät verwendet werden muss.

Lackierte Teile:

Bei Bestellungen von lackierten Teilen welche in der Ersatzteilliste nicht in verschiedenen Farben ausgewiesen sind, ist zusätzlich die Farbnummer oder Farbe mit anzugeben.

Technische Änderungen:

Technische Änderungen sowie das Recht der ausschließlichen Auswertung unseres geistigen Eigentums behalten wir uns vor.

EN INSTRUCTIONS

Other languages:

This list of spare parts is also available in other languages. You can get this list from www.kaercher.com in the Service division.
The designation of the part number e.g. 75456380 is equal to 7.545-638.0.

Quantity details:

The quantity details in the spare parts list correspond to the number of pieces of the component installed in the assembly group.

Piece goods:

Spare parts that are sold as piece goods are to be cut to the desired length. The quantities have been indicated as minimum order quantity =1m and must be rounded off to the full meter figure depending on your requirements.

Version/ Plant numbers:

If version or plant numbers are mentioned in the spare parts list, then use the same to check before ordering which spare part needs to be used for your appliance.

Painted parts:

While ordering painted parts that are not mentioned in the spare parts list in their colour variations, please mention the colour number or the colour you require.

Technical changes:

We reserve the right to make technical changes as well as the right to exclusive use of our intellectual property.

FR REMARQUES

Autres langues:

Cette liste de pièces de rechange est disponible en autres langues. Cela est disponible sous www.kaercher.com dans le menu Service.
La désignation du numéro de pièce, par ex. 75456380, correspond au numéro de pièce 7.545-638.0.

Indications de quantité:

Les indications de quantité dans la liste de pièces de rechange correspondre aux nombres de pièces des composant utilisées dans la construction.

Matériel au mètre:

Les pièces de rechange qui sont livrées au mètre doivent être raccourcies à longueur souhaitée par l'acheteur même. Les nombres des pièces sont indiquées en quantité de commande minimale = 1m et doivent être augmentés selon le besoin à une chiffre de mètre complète.

Versions/ Numéros d'usine:

Lorsqu'il sont indiquées des versions ou des numéros d'usine dans la liste de pièces de rechange, vous devez vérifier que composant doit être utilisé pour votre appareil.

Pièces laquées:

Pour commander des pièces laquées, où les différentes couleurs ne sont pas indiquées dans la liste des pièces de rechange, vous devez indiquer en plus le numéro de la couleur ou seulement la couleur.

Modifications techniques:

Nous nous réservons la possibilité des modifications techniques ainsi le droit d'exploitation exclusive de notre propriété intellectuelle.

IT AVVERTENZE

Altre lingue:

Il presente elenco di parti di ricambio è disponibile sul nostro sito Web anche in altre lingue: sotto www.kaercher.com alla voce "Service".

L'indicazione del codice pezzo, ad es. 75456380, corrisponde al codice pezzo 7.545-638.0

Indicazioni di quantità:

Le indicazioni di quantità riportate dall'elenco "parti di ricambio" corrispondono al numero delle singole componenti contenute nella rispettiva unità.

Merce a metro:

Le parti di ricambio fornite come "merce a metro" devono venire in seguito accorciate alla lunghezza necessaria per il montaggio. La quantità unitaria è indicata come "quantità minima di ordinazione = 1m" e deve all'occorrenza venire moltiplicata per il numero intero di metri necessari.

Versioni / Numeri di fabbricazione:

Quando l'elenco "parti di ricambio" riporta diverse versioni o numeri di fabbricazione, confrontare la versione o il numero di fabbricazione del ricambio desiderato con quelle/i presenti nell'elenco e indicarla/o al momento dell'ordinazione.

Parti di ricambio verniciate:

Nel caso di ricambi verniciati, se l'elenco parti di ricambio non ne riporta espressamente i diversi colori, al momento dell'ordinazione è necessario indicare anche il colore o il numero del colore desiderato.

Modifiche tecniche:

Ci riserviamo il diritto di apportare modifiche tecniche così come il diritto di utilizzo esclusivo della nostra proprietà intellettuale.

ES INDICACIONES

Otros idiomas:

La lista de piezas de repuesto se puede adquirir en otros idiomas. La puede adquirir en www.kaercher.com en el área de servicios.

La notación de los números de las piezas, p.ej. 75456380 corresponde al número de pieza 7.545-638.0.

Cantidades:

Las indicaciones de cantidades de la lista de piezas de repuesto corresponden al número de piezas montadas en el componente.

Mercancía por metros:

Las piezas de repuesto que se suministran por metros se pueden cortar al largo deseado. La unidad mínima de pedido es de = 1 m y el número de metros completos se puede aumentar según necesidad.

Versiones/números de fábrica:

Si se indica la versión o número de fábrica en la lista de piezas de repuesto, se debe comprobar en ella la pieza a usar para su aparato antes de realizar el pedido.

Piezas lacadas:

Al realizar pedidos de piezas lacadas que no estén indicadas en los diferentes colores en la lista de piezas de repuesto, se debe indicar también la referencia del color o el color.

Modificaciones técnicas:

Reservados los derechos de realizar modificaciones técnicas y aprovechar nuestra propiedad intelectual.

PL WSKAZÓWKI

Pozostałe języki:

Ta lista części zamiennych jest dostępna w także w innych językach. Mogą ją Państwo pobrać ze strony www.kaercher.com w dziale Serwis.

Sposób zapisywania numeru części, np. 75456380, odpowiada numerowi części 7.545-638.0.

Dane ilości:

Dane ilości podane w liście części zamiennych odpowiadają liczbie sztuk podzespołów tworzących dany moduł.

Towar sprzedawany na metry:

Części zamienne dostarczane jako towar sprzedawany na metry po zamontowaniu należy samodzielnie skrócić do potrzebnej długości. Liczba sztuk podana jest jako minimalna ilość zamówienia = 1m i w zależności od potrzeb zwiększa się ją o kolejne pełne metry.

Wersje/ Numer zakładu:

Jeżeli w liście części zamiennych podane są wersje lub numery zakładu, przed zamówieniem na ich podstawie należy sprawdzić, który podzespół stosuje się w Państwa urządzeniu.

Części lakierowane:

W przypadku zamówień części lakierowanych, które w liście części zamiennych nie podano w wielu kolorach, należy dodatkowo zaznaczyć nr koloru lub kolor.

Zmiany techniczne:

Zastrzegamy sobie prawo do zmian technicznych oraz wyłącznego wykorzystywania naszej własności intelektualnej.

RU УКАЗАНИЯ:

Другие языки:

Данный список запасных частей также доступен на других языках. Вы найдете его на сайте www.kaercher.com в разделе Service
Маркировка номера детали, например, 75456380, соответствует номеру детали 7.545-638.0.

Указание количества:

Количественные данные в списке запасных частей соответствуют числу компонентов, входящих в состав узлов.

Товар, продаваемый на метры:

Запасные части, продающиеся на метры, необходимо обрезать до нужной длины. Число изделий указано в виде минимального объема заказа = 1м и их количество можно округлить до требуемого по мере необходимости.

Варианты исполнения/заводские номера:

Если варианты исполнения или заводские номера указаны в списке запасных частей, то перед заказом необходимо проверить, какая деталь подходит для вашего устройства.

Лакированные детали:

При заказе лакированных деталей, варианты расцветки которых не указаны в списке запасных частей, необходимо дополнительно указать номер цвета или необходимый для вас цвет.

Технические изменения:

Мы оставляем за собой право на технические изменения, а также право на исключительное использование нашей интеллектуальной собственности.

Table of contents

Spare parts list B 40 C Bp (5.971-698.0)	6
10 Tank (0.165-944.0)	7
11 Tank (0.165-945.0).....	8
12 Covering cap rear (0.165-618.0)	11
20 Frame (0.165-987.0).....	13
30 Vacuum motor (0.165-988.0)	15
40 Control panel (0.165-625.0)	17
50 Tachograph (0.113-926.0)	19
60 Electronics (0.165-986.0).....	21
70 Suction bar lifting (0.165-634.0).....	23
80 Suspension power brush (0.165-637.0).....	25
90 Special tools (0.120-842.0)	27
10 Tool tool - extractor system Molex (0.120-082.0)	28
20 Tool service module A9 (0.120-086.0)	30
30 Tool hydrometer acid (0.120-087.0)	32
40 Tool potentiometer DC (0.120-088.0)	34
50 Tool magnetic field tester (0.120-104.0)	36
60 Tool tester electric Metratester5 (0.120-160.0).....	38

Spare parts list B 40 C Bp (5.971-698.0)

Pos	Material #	Name	Qty.	Unit
10	0.165-944.0	Tank	1.000	ST
20	0.165-987.0	Frame	1.000	ST
30	0.165-988.0	Vacuum motor	1.000	ST
40	0.165-625.0	Control panel	1.000	ST
50	0.113-926.0	Tachograph	1.000	ST
60	0.165-986.0	Electronics	1.000	ST
70	0.165-634.0	Suction bar lifting	1.000	ST
80	0.165-637.0	Suspension power brush	1.000	ST
90	0.120-842.0	Special tools	1.000	ST

10 Tank (0.165-944.0)

Pos	Material #	Name	Qty.	Unit
11	0.165-945.0	Tank	1.000	ST
12	0.165-618.0	Covering cap rear	1.000	ST

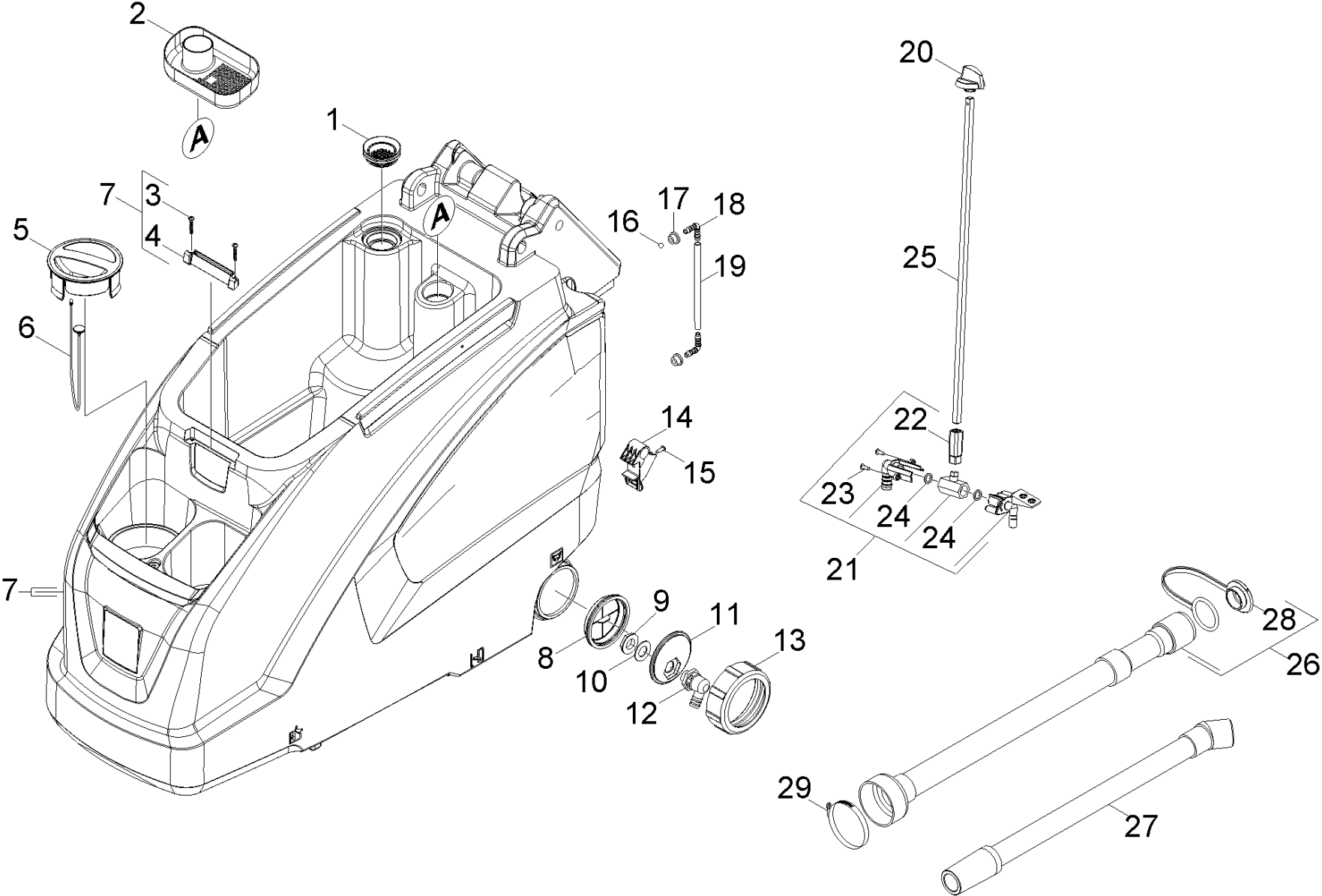

11 Tank (0.165-945.0)

ET/VT (spare/wear parts)	Pos	Material #	Name	Qty.	Unit	Footnote text
X-X	1	5.515-266.0	Joint ring fluffing strainer	1.000	ST	
	2	5.035-375.0	Tank bulk waste	1.000	ST	
X-X	3	7.303-086.0	Screw 5x30 -10.9-R2R (K-In6Rd)	2.000	ST	
	4	5.035-482.0	Add-on part tank cover	1.000	ST	
	5	5.035-380.0	Cover fresh water filler neck	1.000	ST	
	6	5.035-358.0	Mounting rope cover fresh water tank	1.000	ST	
	7	4.035-429.0	Tank replacement	1.000	ST	
X	8	5.035-376.0	Filter discharge	1.000	ST	
	9	6.310-004.0	Hexagon nut G 1/2"	1.000	ST	
X-X	10	5.515-253.0	Seal D34	1.000	ST	
	11	5.035-342.0	Hose connection fresh water discharge	1.000	ST	
X-X	12	6.395-163.0	Angle bushing G1-2	1.000	ST	
	13	5.035-341.0	Cover fresh water tank discharge	1.000	ST	
	14	5.035-433.0	Adapter	2.000	ST	
	16	6.035-006.0	Sphere level indicator	1.000	ST	
	17	5.035-608.0	Wire protecting sleeve	2.000	ST	
X	18	6.391-913.0	Elbow nipple	2.000	ST	
	19	5.035-328.0	Silicon hose level indicator	1.000	ST	
	20	5.035-404.0	Handle	1.000	ST	
	21	4.035-426.0	Ball valve complete replacement	1.000	ST	
	22	5.035-459.0	Coupler piece ball valve	1.000	ST	
X-X	23	7.303-107.0	Screw 5x16 -10.9-P2R (K-In6Rd)	2.000	ST	
	24	5.035-408.0	Seal holder ball valve	2.000	ST	
	25	5.035-369.0	Bar	1.000	ST	
	26	4.035-501.0	Drain hose with cover oil resistant B40/	1.000	ST	OIL RESISTANT

11 Tank (0.165-945.0)

ET/VT (spare/wear parts)	Pos	Material #	Name	Qty.	Unit	Footnote text
	26	4.035-442.0	Drain hose with cover yellow	1.000	ST	STANDARD
	27	6.392-267.0	Suction hose DN32	1.000	ST	STANDARD
X	27	6.392-936.0	Suction hose oil resistant B40/60	1.000	ST	OIL RESISTANT
X	28	5.035-815.0	Cover drain hose oil resistant	1.000	ST	OIL RESISTANT
	28	5.035-723.0	Cover drain hose yellow	1.000	ST	STANDARD
X	29	6.388-767.0	Hose clip 70- 90	1.000	ST	

12 Covering cap rear (0.165-618.0)

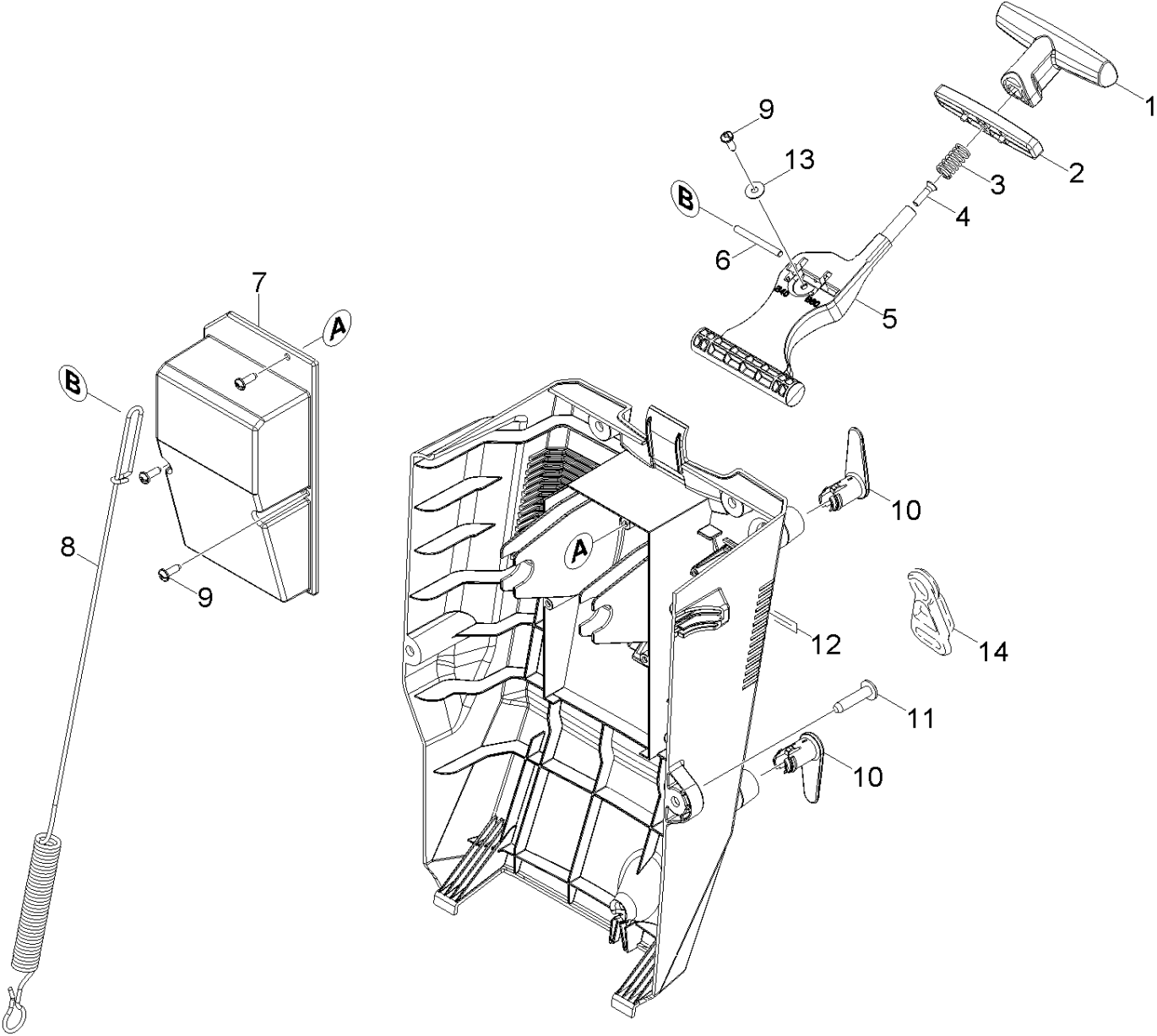

12 Covering cap rear (0.165-618.0)

ET/VT (spare/wear parts)	Pos	Material #	Name	Qty.	Unit
	1	5.035-443.0	Handhold adjustment	1.000	ST
	2	5.326-028.0	Button	1.000	ST
	3	5.332-481.0	Helical spring	1.000	ST
	4	7.305-050.0	Countersunk screw M5x20 -A2-70-s (In6Rd	1.000	ST
	5	5.035-445.0	Lever suction bar	1.000	ST
	6	5.035-453.0	Axle lever suction bar	1.000	ST
	7	5.035-446.0	Cover covering cap rear	1.000	ST
	8	5.035-423.0	Extension spring	1.000	ST
X-X	9	7.303-107.0	Screw 5x16 -10.9-P2R (K-In6Rd)	3.000	ST
X-X	10	5.044-661.0	Catch for cable	2.000	ST
	11	6.303-315.0	Screw 8 x 35	4.000	ST
	12	5.035-366.0	Covering cap	1.000	ST
X-X	13	7.312-282.0	Washer 5 -A2 ISO 7093-1	1.000	ST
	14	6.641-776.0	Strain relief	1.000	ST

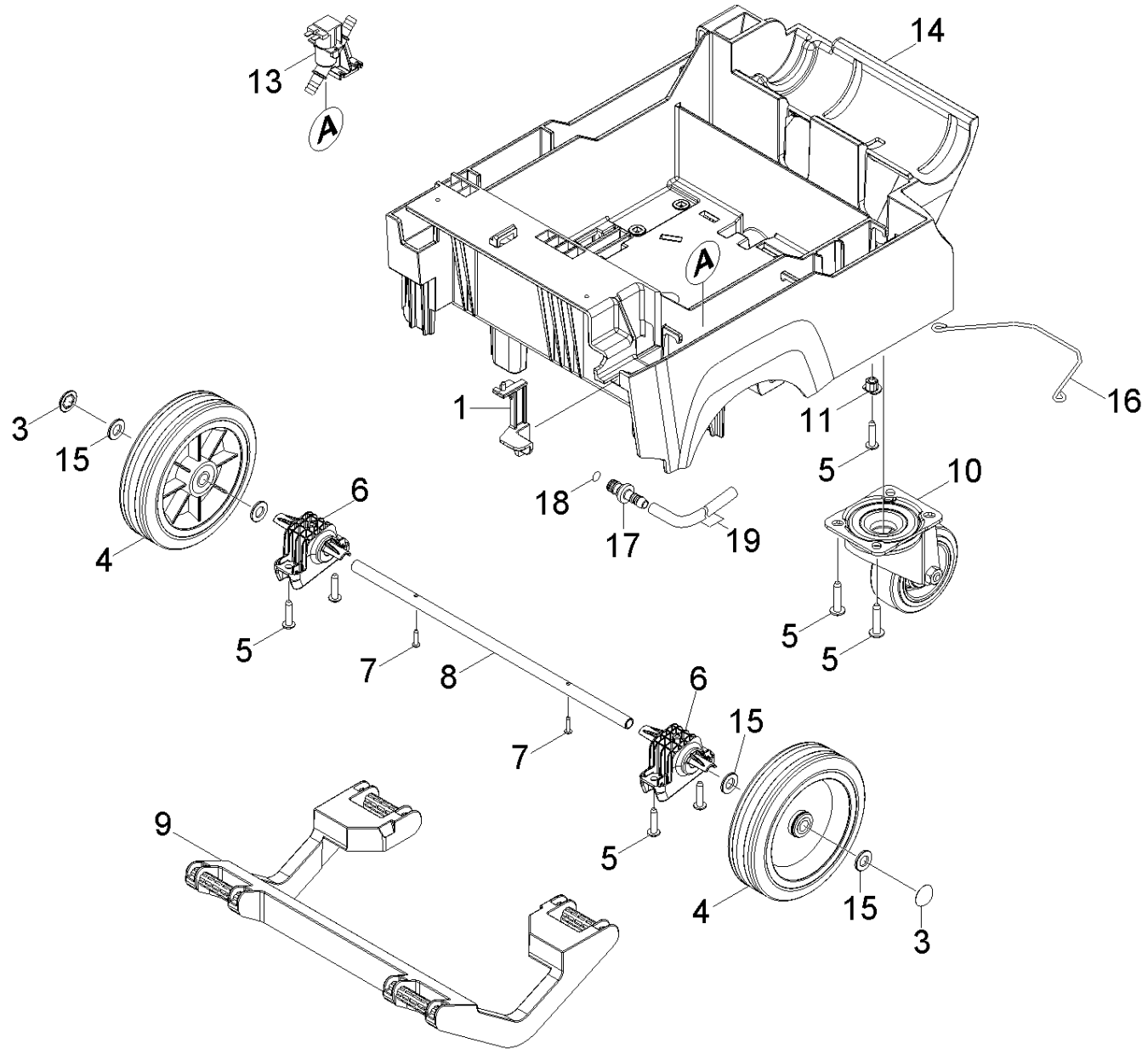

20 Frame (0.165-987.0)

ET/VT (spare/wear parts)	Pos	Material #	Name	Qty.	Unit	var. information	Footnote text
	1	5.035-435.0	Tank locking part	1.000	ST		
	3	6.343-240.0	Lock washer	2.000	ST		
X-X	4	6.435-356.0	Wheel D200	2.000	ST		
	5	6.303-315.0	Screw 8 x 35	15.000	ST		
	6	5.035-352.0	Holder axle	2.000	ST		
	7	6.303-200.0	Screw 5x25-IN6RD	2.000	ST		
	8	5.035-360.0	Wheel axle carriage	1.000	ST		
	9	5.035-334.0	Retaining bracket connecting rod	1.000	ST		
X-X	10	6.435-822.0	Castor	2.000	ST		
	11	5.035-522.0	Sleeve	3.000	ST		
X-X	13	6.472-997.0	Solenoid valve 24V	1.000	ST	24 V	
	14	5.035-350.0	Frame B40	1.000	ST		
X	15	7.312-028.0	Washer 14-200HV-A3E ISO7090	4.000	ST		
	16	5.035-440.0	Wire spring	1.000	ST		
X-X	17	5.443-375.0	Hose stem	1.000	ST		
X-X	18	6.362-170.0	O-Ring seal 11,3 X 2,4-NBR 70	1.000	ST		
X-X	19	6.390-892.0	Spiral hose NW12	1.000	M		TO ORDER AS CUT GOODS

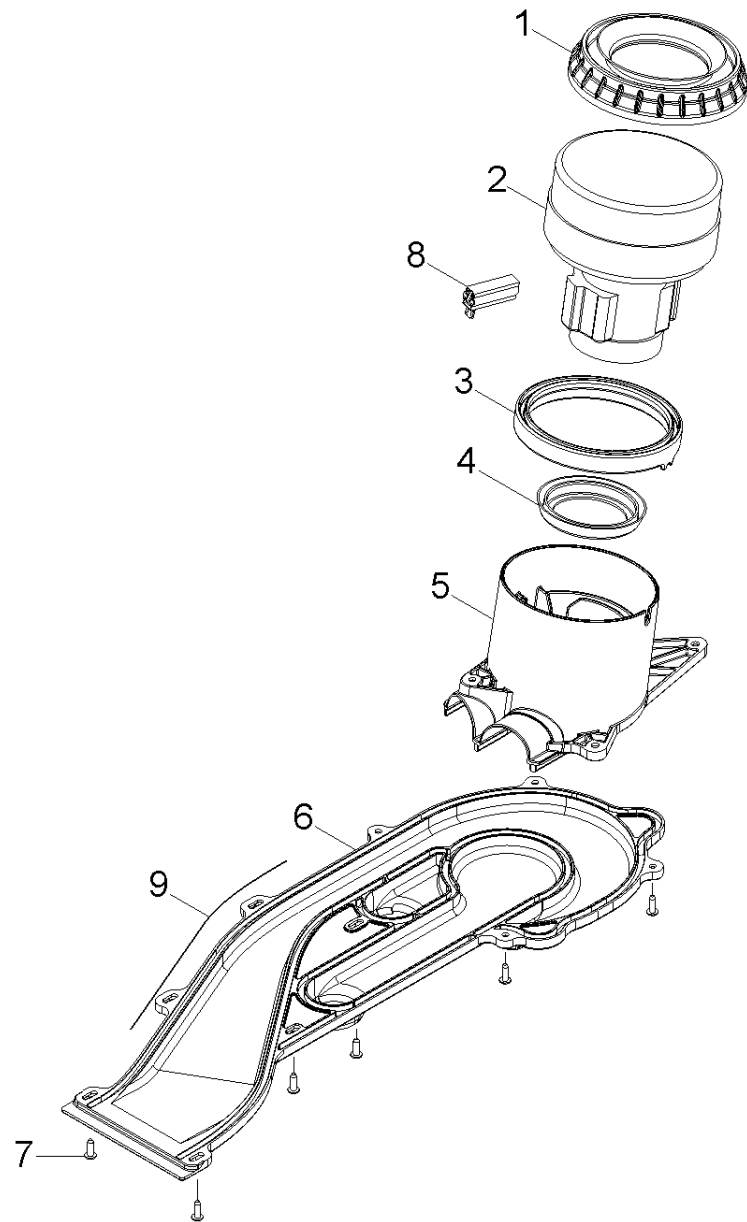

30 Vacuum motor (0.165-988.0)

ET/VT (spare/wear parts)	Pos	Material #	Name	Qty.	Unit	var. information	Footnote text
	1	5.035-333.0	Bearing vacuum motor	1.000	ST		
X	2	4.035-420.0	Vacuum motor replacement	1.000	ST	24 V	
	3	5.035-332.0	Joint ring turbine	1.000	ST		
	4	5.363-395.0	Seal	1.000	ST		
	5	5.035-329.0	Air circulation bottom turbine	1.000	ST		
	6	5.035-331.0	Air circulation above turbine	1.000	ST		
X-X	7	7.303-107.0	Screw 5x16 -10.9-P2R (K-In6Rd)	8.000	ST		
X	8	6.610-333.0	Set carbon brushes for replacement	1.000	ST	24 V	
X-X	9	6.273-196.0	Seal string cellular rubber	1.000	M		TO ORDER AS CUT GOODS

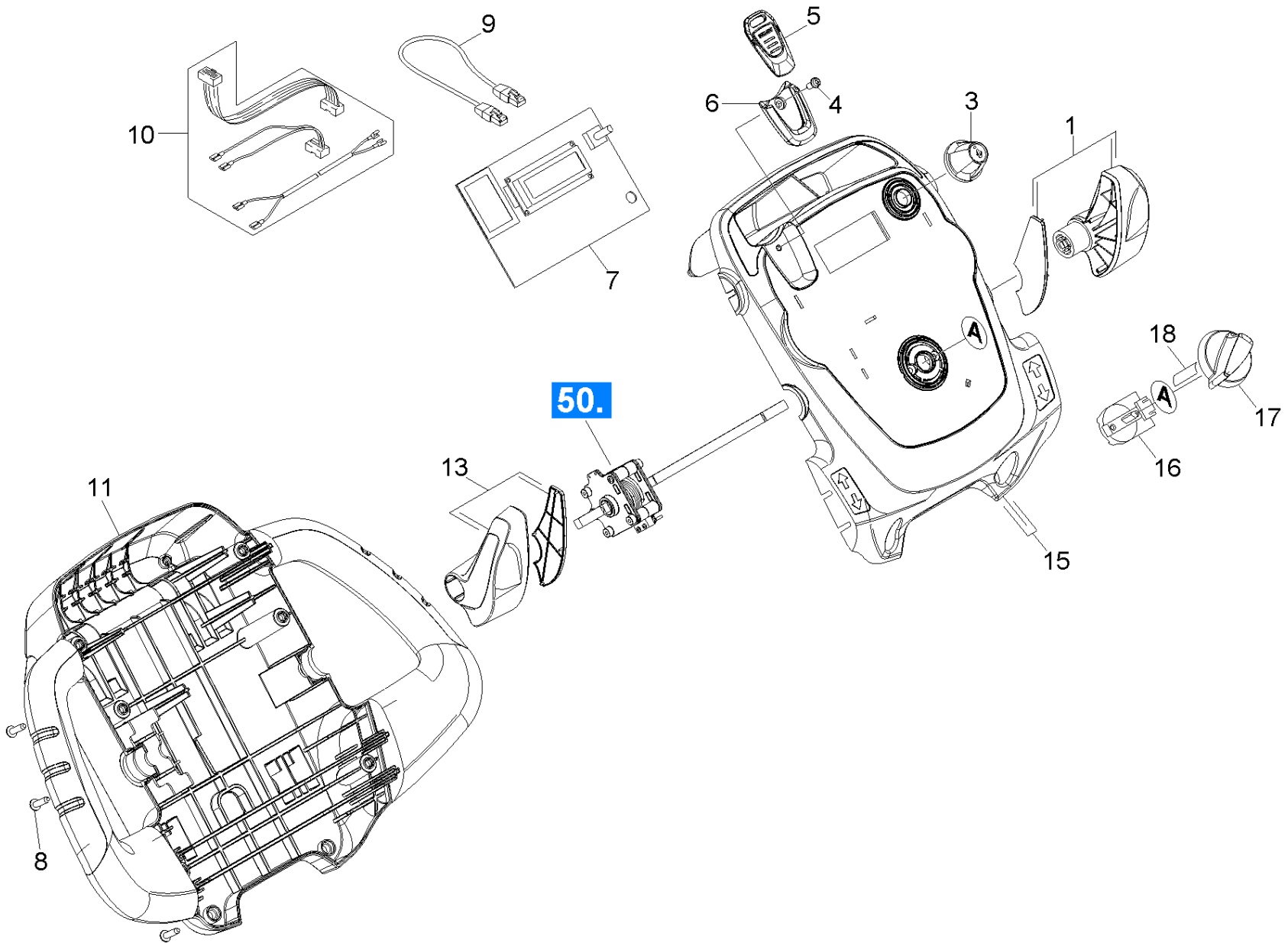

40 Control panel (0.165-625.0)

ET/VT (spare/wear parts)	Pos	Material #	Name	Qty.	Unit	Footnote text
	1	4.035-495.0	Tachograph right complete	1.000	ST	
X-X	3	5.321-750.0	Handhold info panel	1.000	ST	
X-X	4	7.303-116.0	Screw 4x12-A2-70 (IN6RD)	1.000	ST	
	5	5.035-337.0	Key red KIK	1.000	ST	RED
	5	5.035-348.0	Key grey KIK	1.000	ST	GREY
	5	4.035-408.0	Set key yellow KIK	1.000	ST	YELLOW
	6	5.035-343.0	Guide key	1.000	ST	
X	7	6.683-054.0	Circuit board C	1.000	ST	
	8	6.303-200.0	Screw 5x25-IN6RD	6.000	ST	
	9	6.649-933.0	Cable Patch	1.000	ST	
	10	4.035-430.0	Cable harness control panel replacement	1.000	ST	
	11	5.035-346.0	Housing bottom part control panel	1.000	ST	
	13	4.035-496.0	Tachograph left complete	1.000	ST	
	15	4.035-412.0	Covering cap control panel foil Bp C	1.000	ST	
X	16	4.035-415.0	Switch program selection replacement	1.000	ST	
X-X	17	5.321-738.0	Handhold operational concept	1.000	ST	
X-X	18	6.313-014.0	Spring element	1.000	ST	

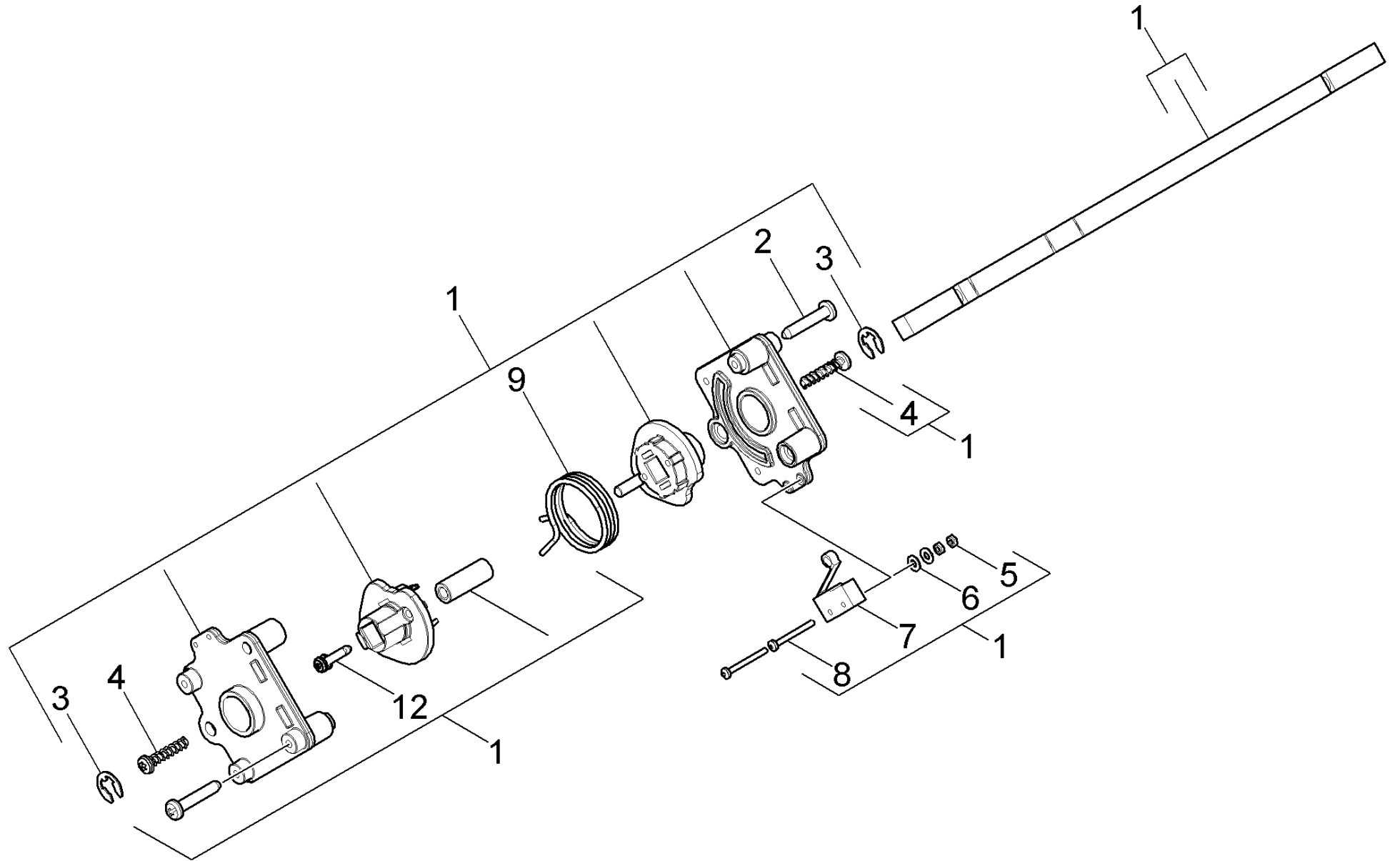

50 Tachograph (0.113-926.0)

ET/VT (spare/wear parts)	Pos	Material #	Name	Qty.	Unit
	1	4.035-475.0	Tachograph set Ep	1.000	ST
	2	7.303-096.0	Screw 4x22 -ST-10.9-R2R (IN6RD)	2.000	ST
X-X	3	7.343-201.0	Lock washer 6-FST-PHR DIN 6799	2.000	ST
X	4	7.306-076.0	Screw M 5x12-ST- 8.8-A2R (IN6RD)	2.000	ST
X-X	5	7.311-074.0	Hexagon nut M 2-8-A2E ISO 4032	2.000	ST
X-X	6	7.312-053.0	Washer 2,5-200HV-A3E ISO 7089	2.000	ST
X	7	6.630-501.0	Switch	1.000	ST
X-X	8	7.306-045.0	Screw M2x20 -8.8-A2R (In6Rd)	2.000	ST
	9	6.330-441.0	Torsion spring tachograph	1.000	ST
	12	7.303-092.0	Screw 3x12 -10.9-R2R (K-In6Rd)	2.000	ST

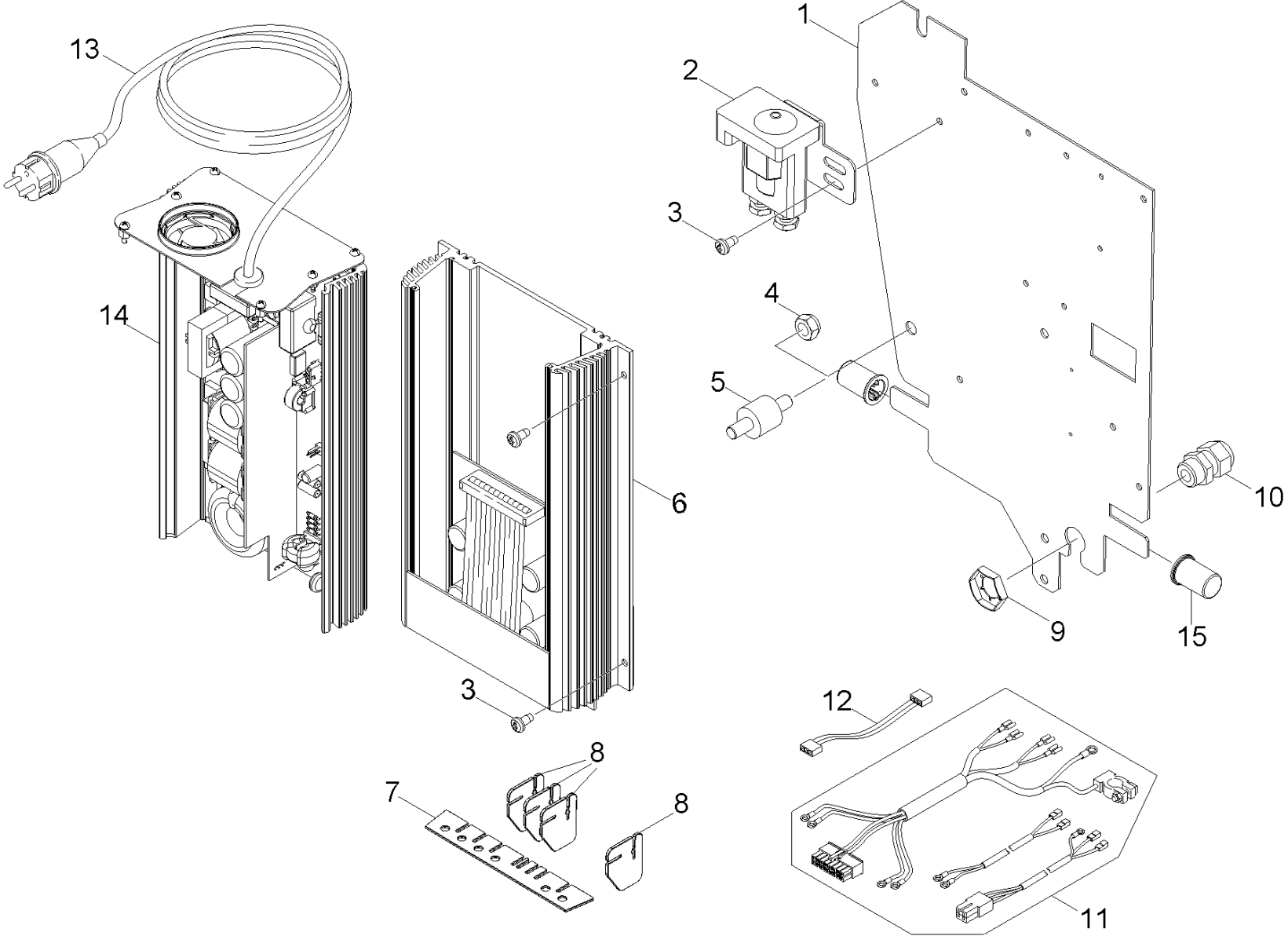

60 Electronics (0.165-986.0)

ET/VT (spare/wear parts)	Pos	Material #	Name	Qty.	Unit	var. information
	1	5.035-449.0	Plate base plate electronics	1.000	ST	
X-X	2	6.633-389.0	Power relay	1.000	ST	
X-X	3	7.303-037.0	Screw M5x10 -St-P2R (In6Rd)	6.000	ST	
X-X	4	7.311-427.0	Hexagon nut M8 -04-A2E ISO 10511	1.000	ST	
	5	6.652-033.0	Isolator	1.000	ST	
	6	6.683-117.0	Electronics control system replacement B	1.000	ST	B 40 C
	7	5.035-362.0	Moulded part plate electronics	1.000	ST	
	8	5.035-359.0	Moulded part plate electronics klein	4.000	ST	
	9	7.311-046.0	Lock nut M16-A2 DIN 7967	1.000	ST	
X	10	6.648-399.0	Cable gland black M16x1,5	1.000	ST	
	11	4.822-741.0	Cable harness B40 C Bp	1.000	ST	/"C Bp""
	12	6.645-554.0	Connecting cable control system battery	1.000	ST	
	13	6.645-585.0	Cable with plug B40-JP	1.000	ST	*JP
	13	6.645-553.0	Cable with plug	1.000	ST	*EU
	14	6.683-119.0	Battery charger replacement B40	1.000	ST	
	15	5.035-450.0	Bearing bush electronics	2.000	ST	

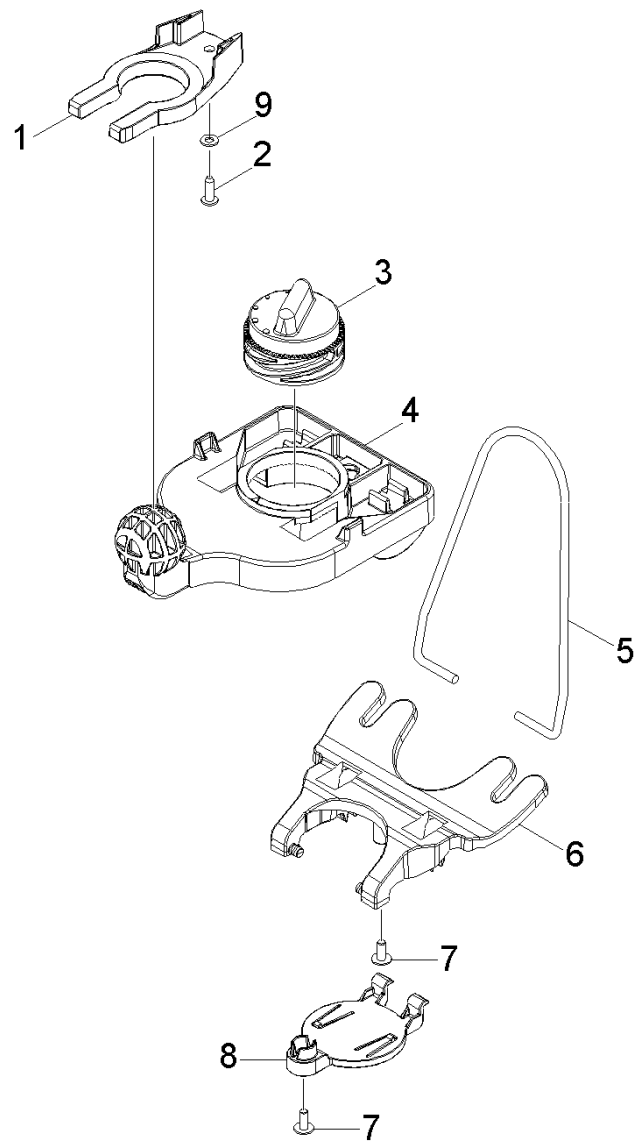

70 Suction bar lifting (0.165-634.0)

ET/VT (spare/wear parts)	Pos	Material #	Name	Qty.	Unit
	1	5.035-353.0	Fixing plate suction bar	1.000	ST
	2	7.303-109.0	Screw 5x25 -10.9-R2R (In6Rd)	1.000	ST
	3	5.035-356.0	Adjusting knob suction bar	1.000	ST
	4	5.035-354.0	Holder suction bar	1.000	ST
	5	5.035-382.0	Retaining bracket suction bar	1.000	ST
	6	5.035-355.0	Rocker suction bar	1.000	ST
X-X	7	6.304-121.0	Oval head screw M 5X12	2.000	ST
	8	5.035-436.0	Covering cap suction bar	1.000	ST
X-X	9	7.312-282.0	Washer 5 -A2 ISO 7093-1	1.000	ST

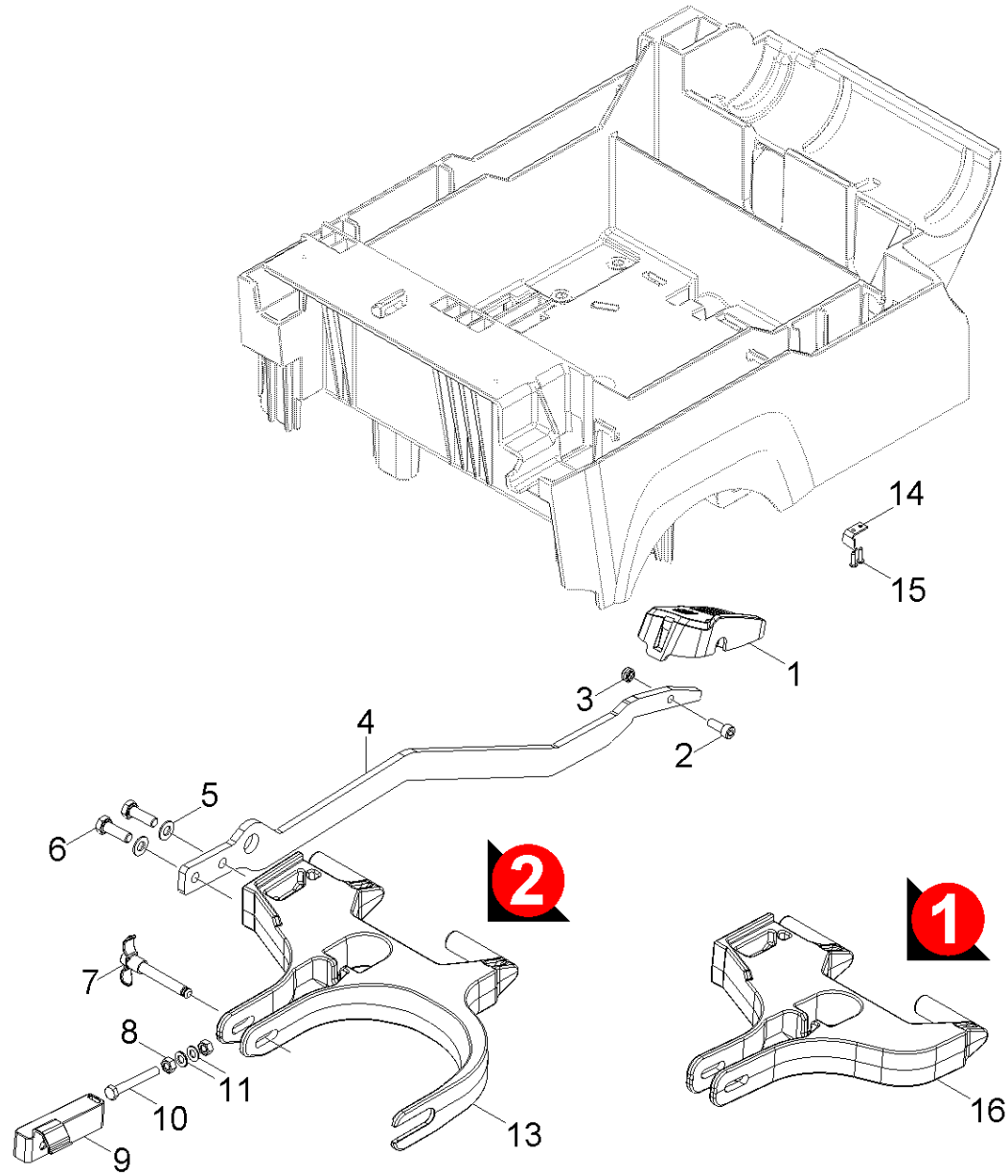

80 Suspension power brush (0.165-637.0)

ET/VT (spare/wear parts)	Pos	Material #	Name	Qty.	Unit	Footnote text
	1	5.035-374.0	Pedal brush-head	1.000	ST	
X-X	2	7.306-041.0	Cylinder head screw M8x20 -8.8-A2E ISO	1.000	ST	
X-X	3	7.311-514.0	Hexagon nut M 8-A2-70 ISO 7040	1.000	ST	
	4	5.035-370.0	Lever plate brush-head	1.000	ST	
X-X	5	7.312-005.0	Washer 10-200HV-A3E ISO 7090	2.000	ST	
X-X	6	7.304-417.0	Hexagonal head screw M10x30-8.8-A3E ISO	2.000	ST	
	7	5.035-865.0	Handhold bolt brush-head	1.000	ST	
X-X	8	7.311-068.0	Hexagon nut M 8-A2-70 ISO 4032	2.000	ST	
	9	5.035-377.0	Adjusting element brush-head	1.000	ST	
X-X	10	7.304-262.0	Hexagonal head screw M8x60-A4-70 ISO 40	1.000	ST	
X-X	11	7.312-004.0	Washer 8 -200HV-A3E ISO 7090	2.000	ST	
	13	5.035-675.0	Suspension brush-head triple	1.000	ST	VERSION 2
	14	5.035-361.0	Sheet metal component	1.000	ST	
X-X	15	7.303-113.0	Screw 6x25 -10.9-R2R (In6Rd)	2.000	ST	
	16	2.882-733.0	Conversion kit suspension brush-head B40	1.000	ST	VERSION 1

90 Special tools (0.120-842.0)

Pos	Material #	Name	Qty.	Unit
10	0.120-082.0	Tool tool - extractor system Molex	1.000	ST
20	0.120-086.0	Tool service module A9	1.000	ST
30	0.120-087.0	Tool hydrometer acid	1.000	ST
40	0.120-088.0	Tool potentiometer DC	1.000	ST
50	0.120-104.0	Tool magnetic field tester	1.000	ST
60	0.120-160.0	Tool tester electric Metratester5	1.000	ST

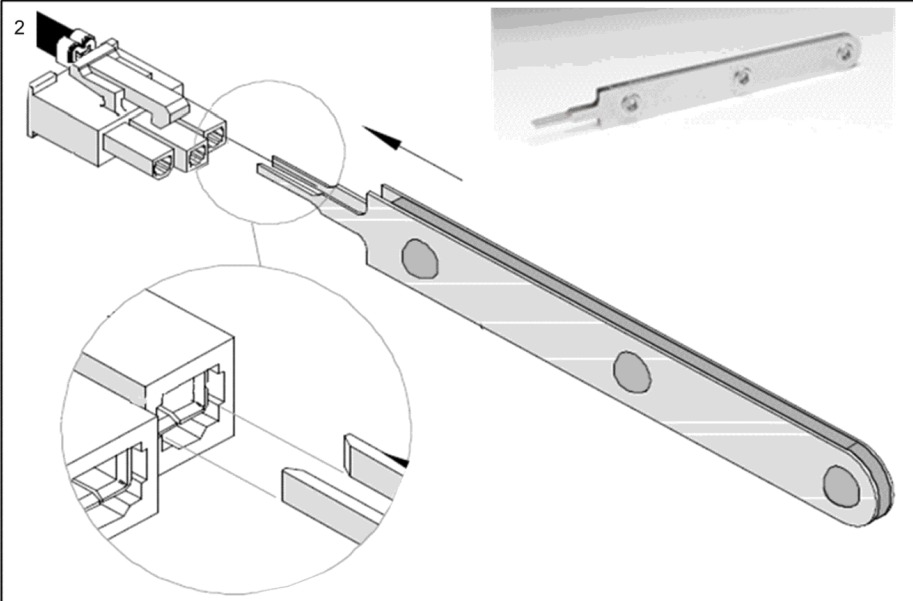
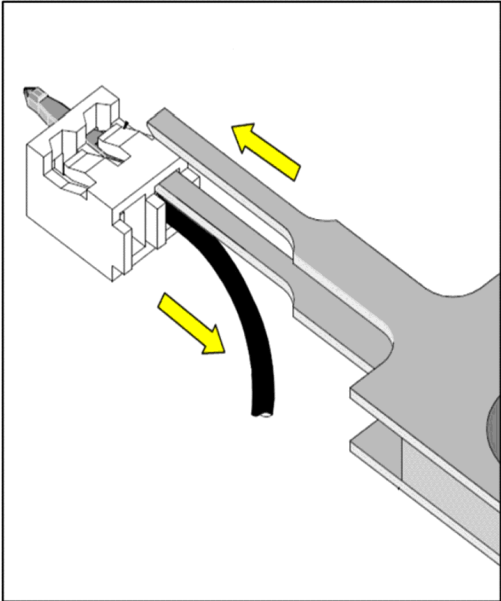
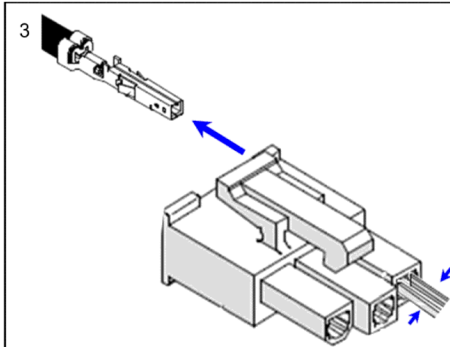
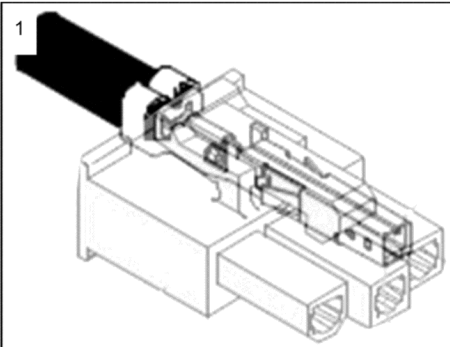
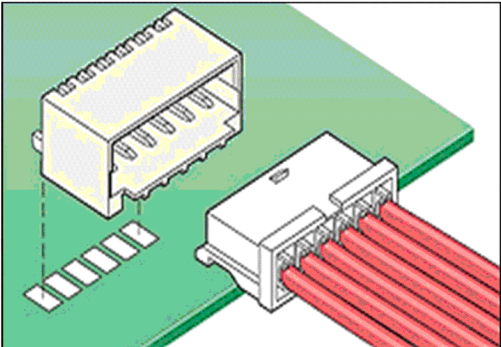
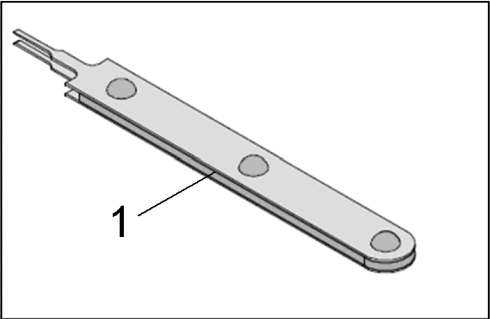

10 Tool tool - extractor system Molex (0.120-082.0)

Pos	Material #	Name	Qty.	Unit
1	6.816-086.0	Pliers Molex	1.000	ST

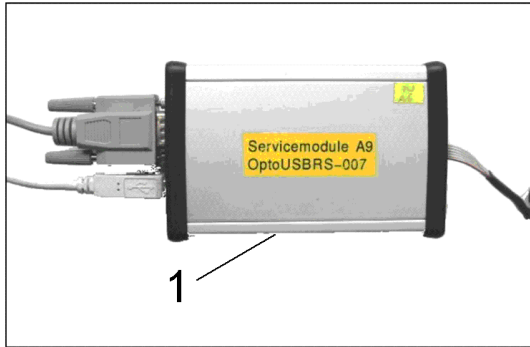

Preparations

- Downloading Installation Files for Service Program**
1. Use Computer with USB and Admin rights
 2. Copy Folder: C:\Kaecher to C:\Kaecher_save
 3. Open Kärcher-Inside:
- DOKUMENTE -> SERVICE -> DOWNLOADS, SCRUBBERS AND SWEEPERS -> SERVICEMODUL-> SERVICE PROGRAMM V5.1-> UPDATE x
 "Service Program Version V5.2 - Installation_CD_USBStick"

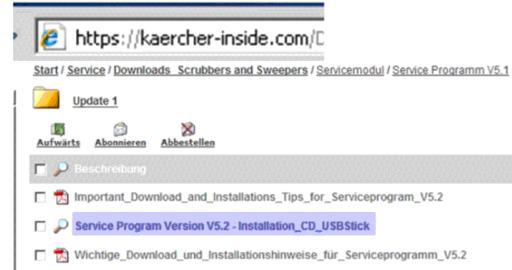

Create external drive and start Installation from there.
 1. Mark extracted files and folder and copy to the external drive
 2. Start „Autostart.exe“ in the external drive.

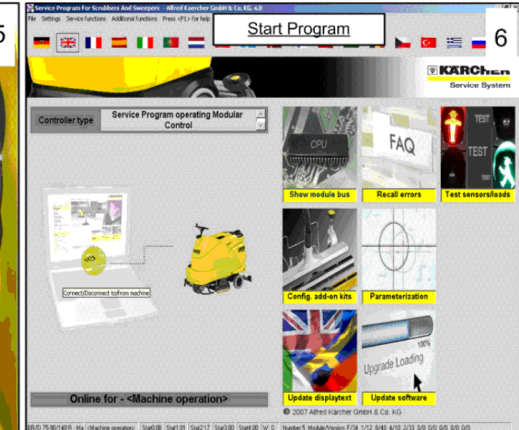
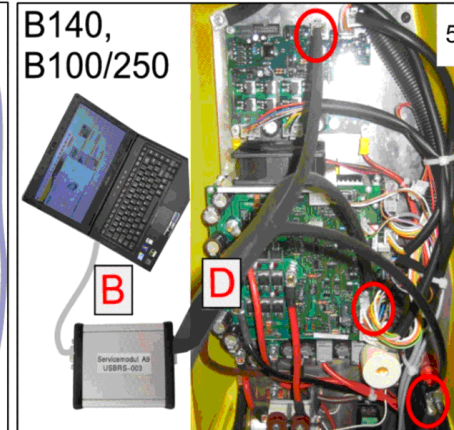
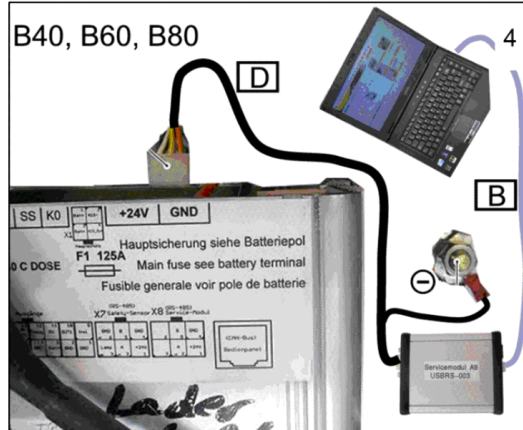
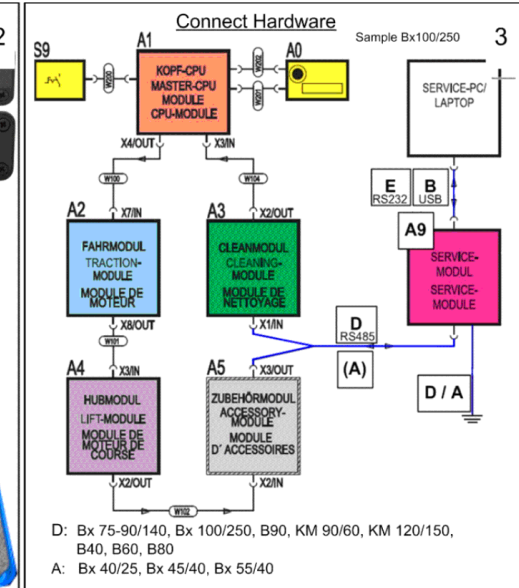
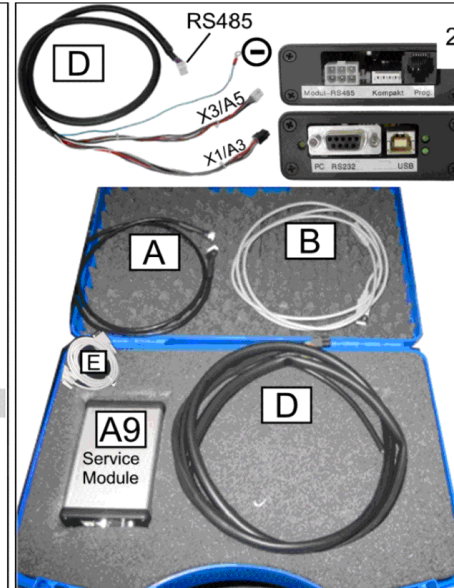

20 Tool service module A9 (0.120-086.0)

ET/VT (spare/wear parts)	Pos	Material #	Name	Qty.	Unit
X-X	1	2.816-117.0	Service module A9	1.000	ST

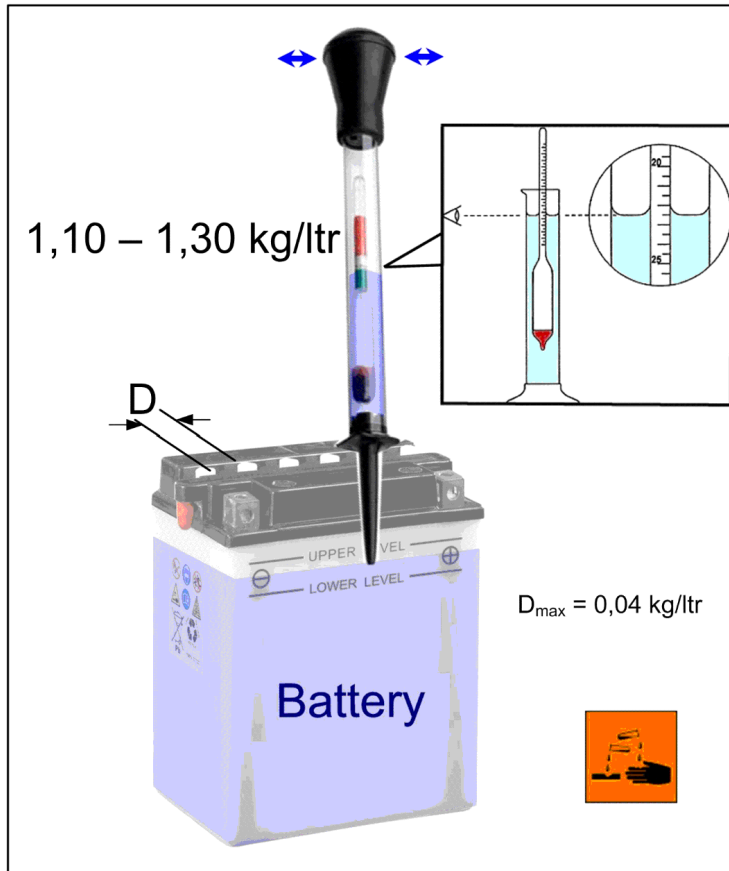
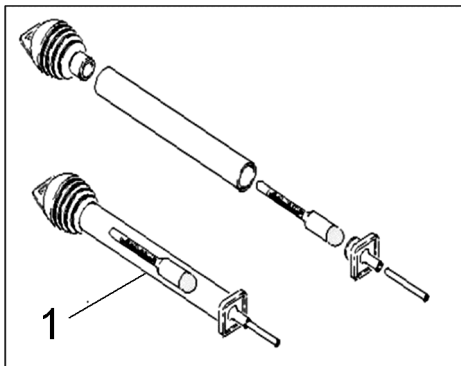

12-Volt Batterie / Battery / Bateria	Ladung / Charge / Carga	Säuredichte / Density / Densité / Densidad [kg/l]	30°C
> 12,80 Volt	100%	1,29	
> 12,55 Volt	75%	1,25	
> 12,32 Volt	50%	1,21	
> 12,18 Volt	25%	1,14	
> 12,00 Volt	entladen / discharge / décharge / descarga	< 1,13	

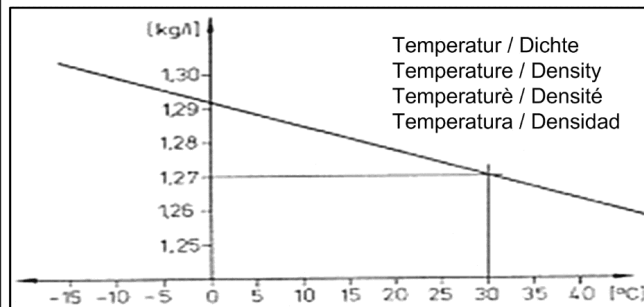

30 Tool hydrometer acid (0.120-087.0)

Pos	Material #	Name	Qty.	Unit
1	6.803-015.0	Battery hydrometer 1,10-1,30kg/l	1.000	ST

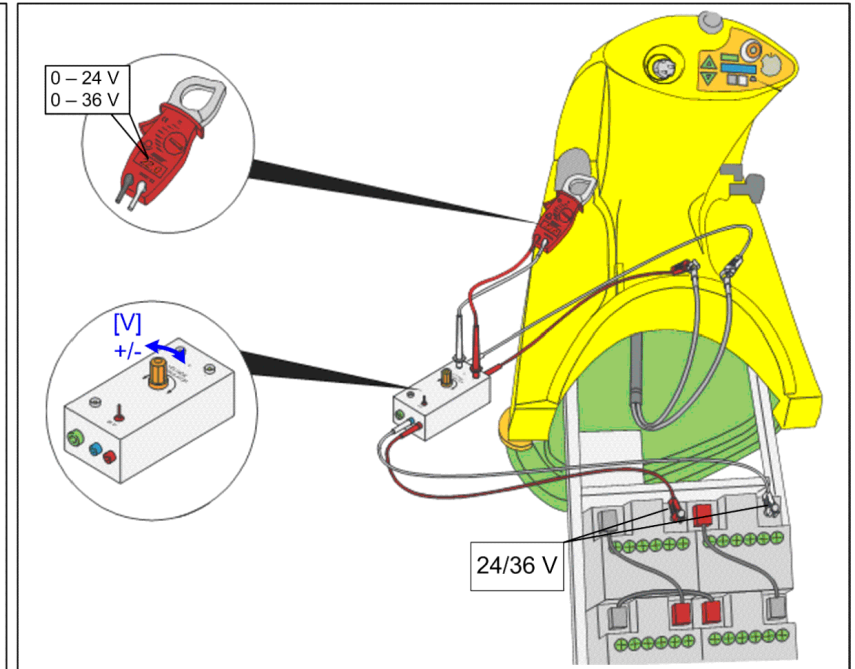
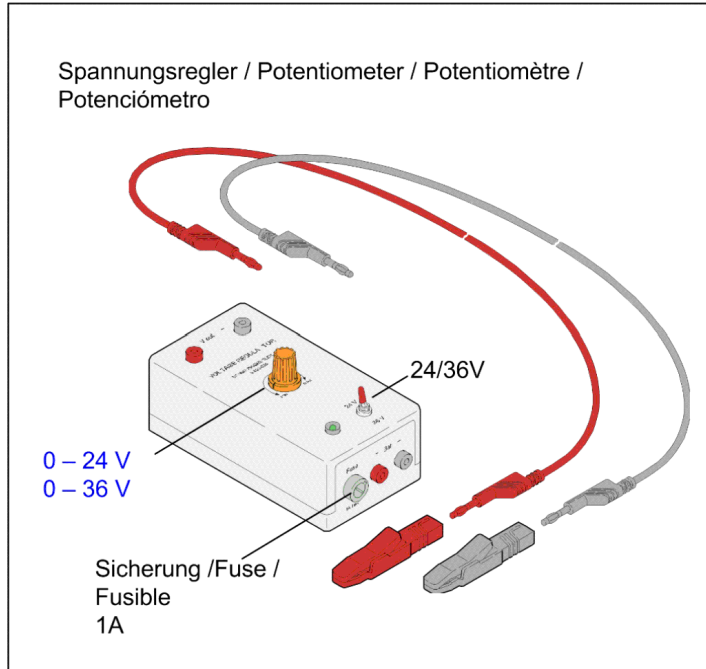
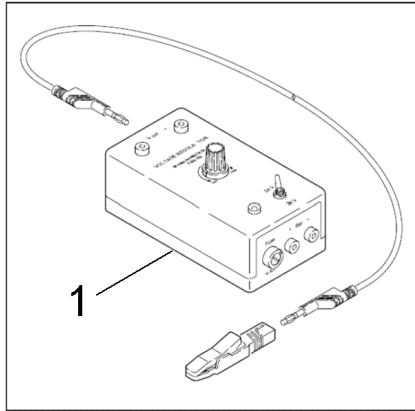

40 Tool potentiometer DC (0.120-088.0)

Pos	Material #	Name	Qty.	Unit
1	6.803-025.0	Voltage tester 24/36V,DC	1.000	ST

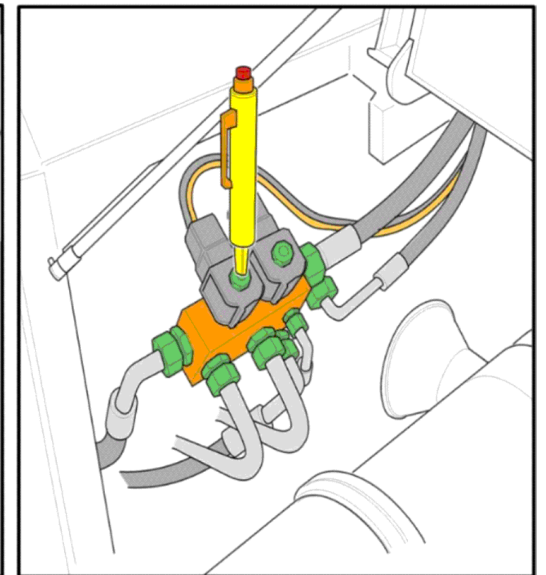
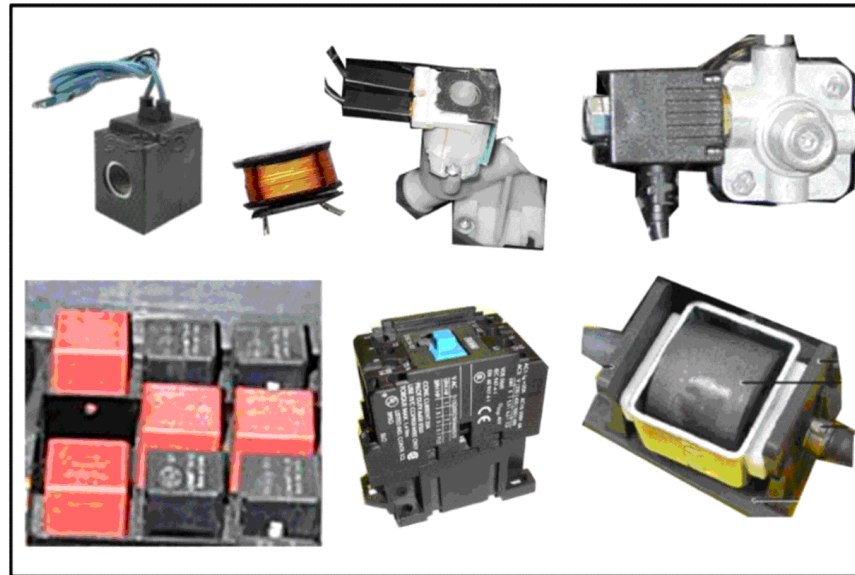
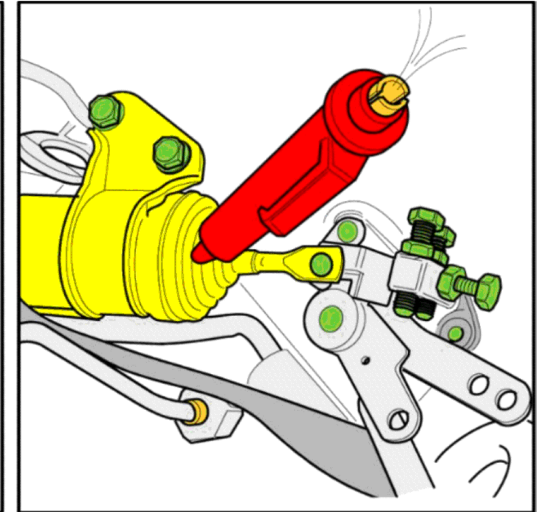
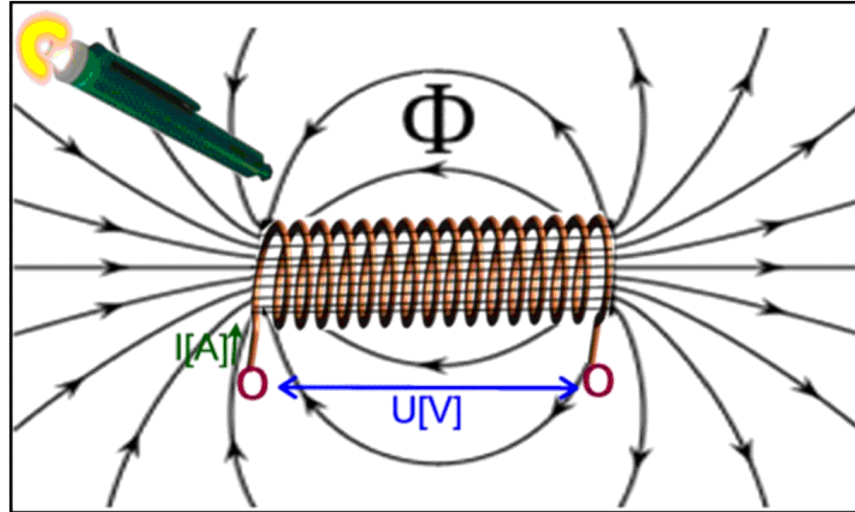
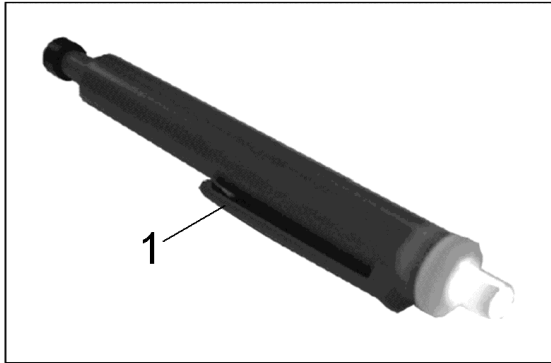

50 Tool magnetic field tester (0.120-104.0)

Pos	Material #	Name	Qty.	Unit
1	6.803-003.0	Magnet tester	1.000	ST



Das Prüfgerät ist zum Prüfen und Messen an instandgesetzten oder geänderten elektrischen Geräten nach DIN VDE 0701 oder DIN VDE 0702 bestimmt. Gemäß diesen Vorschriften müssen nach einer Instandsetzung oder Änderung elektrischer Geräte der Schutzleiterwiderstand, der Isolationswiderstand, der Ersatz-Ableitstrom und bei Datenverarbeitungseinrichtungen und Büromaschinen die Spannungsfreiheit berührbarer leitfähiger Teile gemessen werden.

The tester is intended for the testing and measurement of repaired or modified electrical devices in accordance with DIN VDE 0701-702. These regulations require the measurement of protective conductor resistance, insulation resistance and equivalent leakage current for repaired or modified electrical devices, as well as testing for the absence of voltage at exposed, conductive parts for data processing systems and office machines.

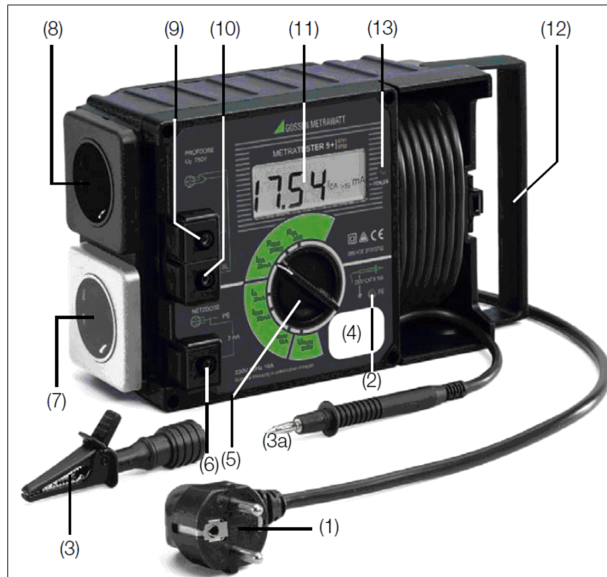

(2) Signallampe PE zur Prüfung des Netzschutzleiters
Die Signallampe PE leuchtet, wenn zwischen der berührten Kontaktfläche (4) und dem Schutzkontakt des Netzanschlusstekkers (1) eine Potentialdifferenz von ≥ 100 V besteht.

(3) Krokodilklemme (Greifklemme zum Aufstecken auf die Prüfspitze)
Mit der Krokodilklemme schließen Sie, zur Messung des Schutzleiterwiderstandes, das Gehäuse des Prüflings an. Achten Sie dabei auf guten Kontakt.

(4) Kontaktfläche für Fingerkontakt
Beim Berühren der Kontaktfläche leuchtet die Signallampe (2), wenn zwischen dem Schutzleiter PE des Netzanschlusstekkers (1) und der berührten Kontaktfläche eine Potentialdifferenz von ≥ 100 V besteht. Die Kontaktfläche ist von allen Anschlüssen und von der Messschaltung galvanisch getrennt und entspricht somit der Schutzklasse III

Prüfen des Schutzleiterpotentials
Berühren Sie mit dem Finger die Kontaktfläche (4) und gleichzeitig ein geerdetes Teil (z.B. Wasserleitung). Die Signallampe PE (2) darf dabei nicht leuchten! Das Potential zwischen dem Schutzleiter des Netzanschlusstekkers (1) und der Kontaktfläche (4) ist dann ≤ 100 V.

(2) PE Signal Lamp for Protective Conductor Testing
The PE signal lamp lights up, if a potential difference of ≥ 100 V occurs between the contacting surface (4) and the earthing contact at the mains plug (1).

(3) Alligator clip (gripper clip for attachment to the test probe)
Connect the housing of the device under test with the alligator clip for measurement of protective conductor resistance.

(4) Contacting Surface for Contact Finger
The PE signal lamp (2) lights up, if a potential difference of ≥ 100 V occurs between the PE protective conductor at the mains plug (1) and the contacting surface. The contacting surface is electrically isolated from all terminals, as well as from the measuring circuit, and thus conforms to protection class III!

Testing Protective Conductor Potential
Bring the contact finger into contact with the contacting surface (4) and, at the same time, with a grounded object (e.g. a water pipe). The PE signal lamp (2) must not light up! Potential between the mains plug protective conductor (1) and the contacting surface (4) is then ≤ 100 V.

Anschließen des Prüflings (A) an das Prüfgerät
Für die Messung von Schutzleiterwiderstand, Isolationswiderstand und Ersatz-Ableitstrom

Connecting the Device Under Test to the Test Instrument
for the measurement of protective conductor resistance, insulation resistance and equivalent leakage current

DUT with protective conductor (Safety Class I) and Mains Plug / Prüflinge der Schutzklasse I mit Netzstecker

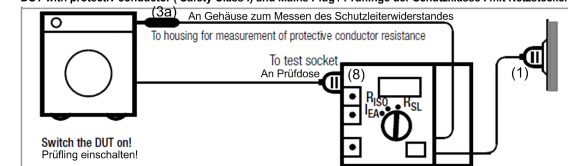

Safety Class II DUT / Prüflinge der Schutzklasse II

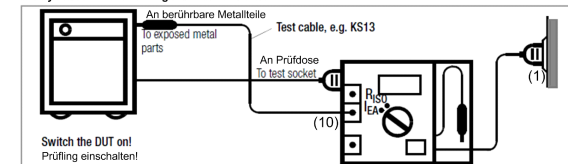

DUT Without Mains Plug or Safety Class III DUT / Prüflinge ohne Netzstecker und Prüflinge der SK III

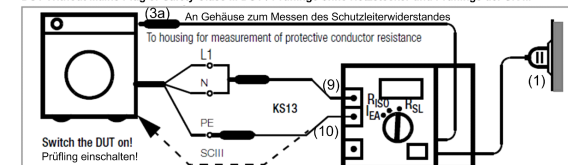

3-Phase DUT / Prüflinge für Drehstrom-Anschluss

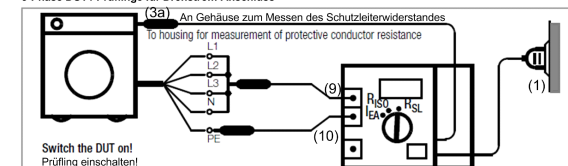

60 Tool tester electric Metrater5 (0.120-160.0)

Pos	Material #	Name	Qty.	Unit
1	6.803-034.0	Electrical tester Metrater5	1.000	ST
