

PARTS LIST
STALLION 12 SC

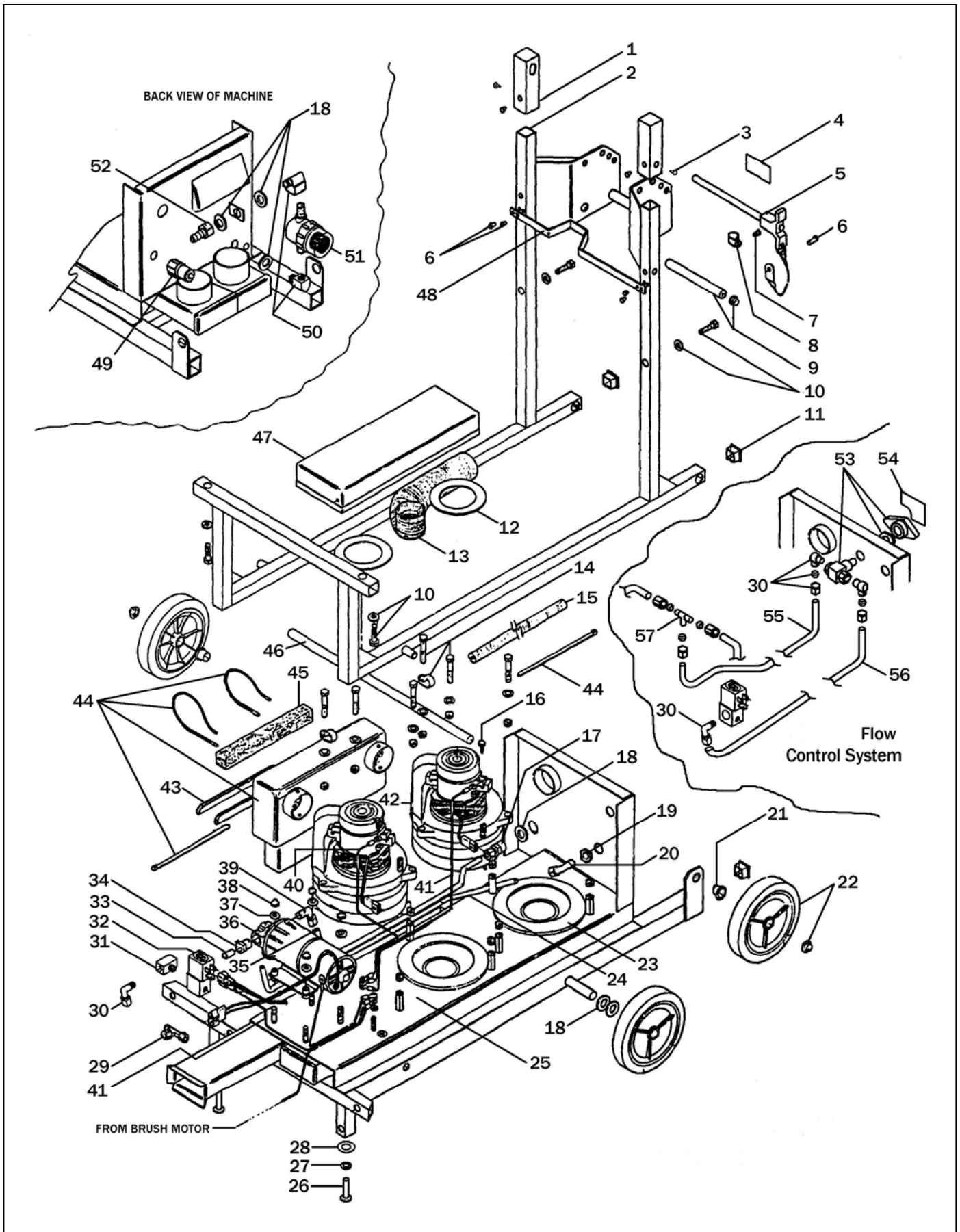

<u>ITEM</u>	<u>PART NO.</u>	<u>DESCRIPTION</u>	<u>QTY</u>
1	4893491	FRAME EXTENSION VACUUM LID PIVOT	2
2	-----	UPPER FRAME	1
3	4893511	#8 X 1/2 PHILLIPS PAN HEAD SHEET METAL SCREW	4
4	4893521	DRAIN HOSE LABEL	1
5	4893531	RETAINING PIN ASSEMBLY	1
6	4893291	1/8" RIVET	5
7	4893401	#10 X 1/2 PHILLIPS PAN HEAD SHEET METAL SCREW	1
8	4893561	7/16" CABLE CLAMP	1
9	4893571	HANDLE SHAFT ASSEMBLY	1
10	4893581	SOLUTION TANK MOUNTING KIT	1
11	4893591	7/8" SQUARE END CAP	4
12	4893601	COOLING AIR DUCT GASKET	2
13	4893611	EXHAUST HOSE, 1" I.D. X 7" LONG	1
14	-----	VACUUM MOTOR MOUNTING KIT	1
15	4893631	CORRUGATED LOOM, 26" LONG	1
16	4893641	10/32 X 3/8 GROUND SCREW	2
17	4893651	BRASS TUBE FITTING, 1/4" FEMALE NPT X 1/4" COMPRESSION TUBE	1
18	-----	NYLON SPACER, 1/2" I.D. X 1" O.D. X 3/16" THICK	8
19	4893671	1/4" NPT HEX NUT	1
20	4893681	90° ELBOW, 1/4" MALE NPT X 1/4" FEMALE NPT X 1/4" COMPRESSION TUBE	1
21	-----	NYLINER BUSHING, 1/2" I.D.	2
22	4893711	WHEEL ASSEMBLY	2
23	4893721	VACUUM MOTOR GASKET	2
24	4893741	COPPER TUBING, 1/4" O.D. X 25 7/8" LONG	1
25	4893751	LOWER FRAME ASSEMBLY	1
26	4893761	1/4-20 X 3 PHILLIPS PAN HEAD SCREW	2
27	4893771	1/4 SPLIT LOCK WASHER	2
28	4893781	1/4 FLAT WASHER	2
29	4893791	MALE BRANCH TEE, 1/8" MALE NPT X 1/4" COMPRESSION TUBE	1
30	-----	90° ELBOW, 1/8" MALE NPT X 1/4" COMPRESSION TUBE	3
31	4893811	TEE, 1/8" FEMALE NPT	1
32	4893821	SOLENOID, 1/8" NPT (115 VAC)	1
	4893831	SOLENOID, 1/8" NPT (250 VAC)	1
33	4893841	1/8" NPT SHORT NIPPLE	1
34	4893851	BUSHING, 3/8" X 1/8"	1
35	4893861	TUBE, PUMP TO TANK	1
36	4893871	PUMP MOTOR, INTERNAL BYPASS, WITH MOLEX CONNECTOR (115 VAC)	1
	4893881	PUMP MOTOR, INTERNAL BYPASS, WITH MOLEX CONNECTOR (240 VAC)	1
37	4893891	1/4 FLAT WASHER	4
38	4893901	1/4-20 NYLON LOCKNUT	4
39	-----	90° ELBOW, 3/8" MALE NPT X 1/4" COMPRESSION TUBE	1
40	4893921	WIRE ASSEMBLY	1
41	4893931	GROUND WIRE, #1 VAC, 8/12	2
42	4893981	2 STAGE VACUUM MOTOR WITH MOLEX CONNECTOR (115 VAC)	2
	4893991	2 STAGE VACUUM MOTOR WITH MOLEX CONNECTOR (240 VAC)	2
43	4895051	MUFFLER CLIPS	2
44	4895061	MUFFLER ASSEMBLY	1
45	4895081	MUFFLER SUPPORT FOAM	1
46	4895091	WHEEL AXLE	1
47	4895101	COOLING DUCT	1
48	4895111	2" HOSE GUIDE	1
49	4895121	QUICK DISCONNECT, 1/4 MALE X 1/4 FEMALE NPT	1
50	4895131	90° ELBOW, 1/4" FEMALE X 1/4" MALE	2
51	4895141	IN-LINE FILTER STRAINER	1
52	4895151	CONNECTOR, 3/8" BARB X 1/4" FEMALE NPT	1
53	4895161	BALL VALVE	1
54	4892991	SOLUTION FLOW LABEL	1
55	4895181	COPPER TUBING, 1/4" O.D. X 28 1/2" LONG	1
56	4895191	COPPER TUBING, 1/4" O.D. X 30 1/2" LONG	1
57	4895241	TEE, 1/4" COMPRESSION TUBE	1

FRAME ASSEMBLY



BRUSH CHAMBER ASSEMBLY

ITEM	PART NO.	DESCRIPTION	QTY
1	4895251	BRUSH MOTOR ASSEMBLY (115V)	1
2	4895261	RECTIFIER	1
3	4895271	6-32 HEX NUT, NYLON	1
4	4895281	BRUSH MOTOR BRACKET	1
5	4895291	10-32 LOCKNUT, NYLON	2
6	-----	MOTOR PULLEY	1
7	4895311	RECTIFIER MOUNTING BOARD	1
8	4895321	90° ELBOW, 1/8" FEMALE NPT X 1/4" COMPRESSION TUBE	2
9	4895331	BRUSH DRIVE BELT	1
10	4895341	1/4-20 LOCKNUT, NYLON	6
11	4893891	1/4 FLAT WASHER	6
12	4895351	1/4-20 X 1 1/2 CARRIAGE BOLT	6
13	4895361	COPPER TUBE, SOLENOID TO TIP	1
14	4893781	1/4 FLAT WASHER	2
15	4893771	1/4 SPLIT LOCK WASHER	2
16	4895371	1/4-20 X 5/8 HEX HEAD BOLT	2
17	4895381	NYLON WASHER, 7/16 I.D. X 1 1/16 O.D.	2
18	-----	SPRAY TIP, 11003 X 1/8" MALE NPT (50 PSI)	2
	4895401	SPRAY TIP, 11003 X 1/8" MALE NPT (100 PSI)	2
19	4895411	SLIDING BLOCK ASSEMBLY	2
20	4895421	PULLEY END COVER PLATE ASSEMBLY	1
21	4895431	BRUSH PULLEY	1
22	4895441	BRUSH BEARING	2
23	4895451	ROTARY BRUSH SLINGER ASSEMBLY	1
24	4895461	18" BRUSH SHAFT	1
25	4895471	OPEN END COVER PLATE ASSEMBLY	1
26	4895481	WASHER, .5625 O.D. X .395 I.D. X .035 THICK	1
27	4895491	BRUSH	1
28	4895501	STRING GUARD ASSEMBLY	1
29	4896161	NYLON WASHER, 2.00 O.D. X .51 I.D. X .06 THICK	1
30	4896171	BRUSH CHAMBER BRUSH SPACER	2
31	4896181	BRUSH CHAMBER FRONT LIP GUIDE	1
32	-----	BRUSH CHAMBER BACK LIP GUIDE	1
33	4896201	BRUSH CHAMBER ASSEMBLY - INCLUDES FRONT AND BACK GUIDES	1
34	4896211	SPRING COVER PLATE ASSEMBLY	2
35	4896231	COPPER TUBE, SOLENOID TO TIP	1
36	4896241	6-32 X 1/2 SLOTTED HEX HEAD SCREW	1
37	4896251	6-32 X 5/8 PAN HEAD SCREW, NYLON	1

*****NOTE: SEE SECTION APPENDIX I WHEN SERVICING BRUSH DRIVE BELT OR BRUSH ASSEMBLY*****

BRUSH CHAMBER ASSEMBLY

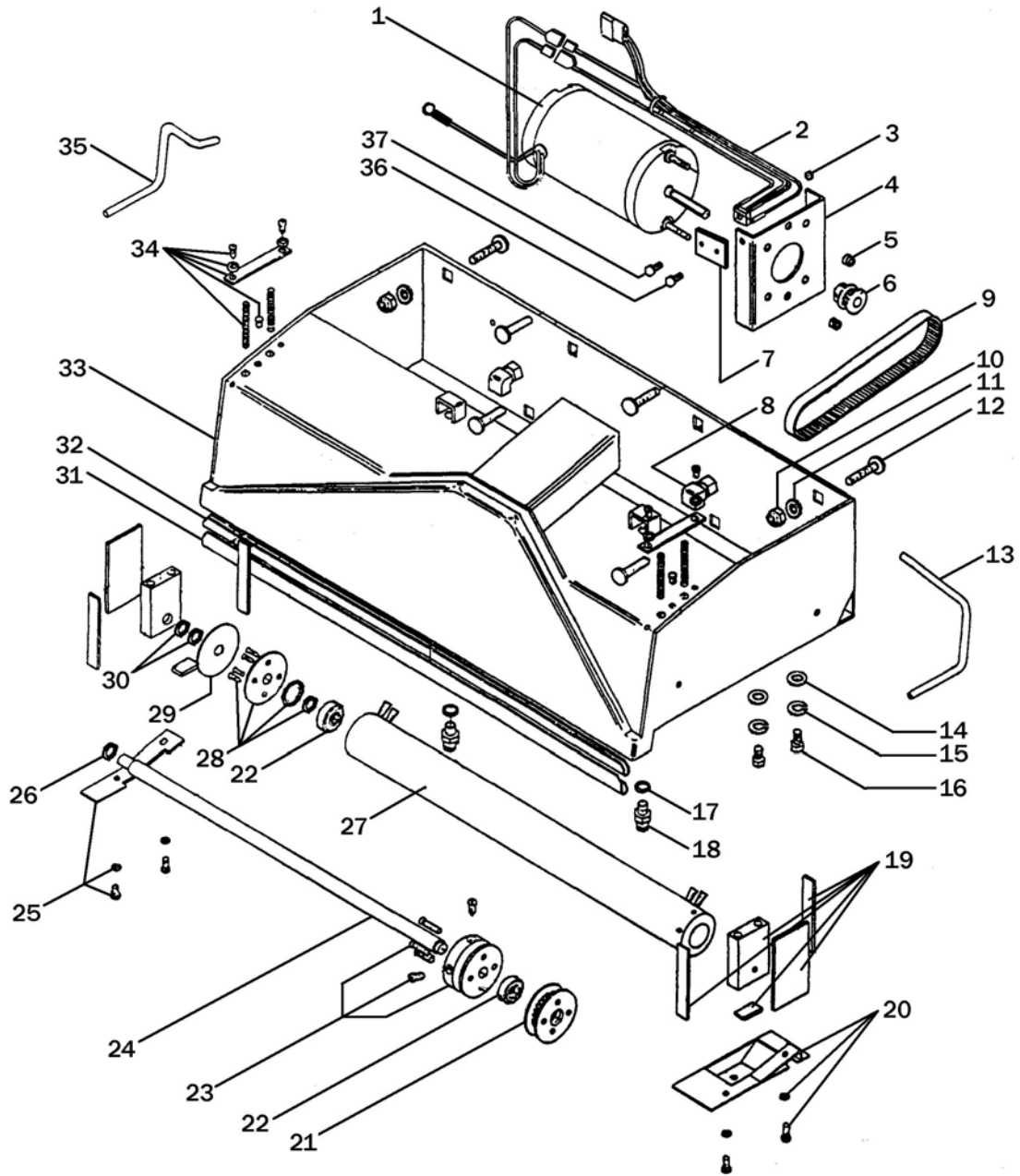

PLASTIC BODY ASSEMBLY

ITEM	PART NO.	DESCRIPTION	QTY
1	4893061	DOME ASSEMBLY - INCLUDES SHAFT	1
	4893481	DOME GASKET, 1/2" THICK, NEOPRENE	1
2	4893071	LID PIVOT SHAFT	2
3	4893081	VACUUM INTAKE SEAL, NEOPRENE	1
4	4893091	1/4-20 JAM NUT	1
5	4893101	SPACER, 1/2 O.D. X .257 I.D. X 5/16 LONG	1
6	4893111	HOSE ADAPTOR	1
7	4893121	RETAINER CLIP ADAPTER	1
8	4893131	1/4-20 X 3/4 PHILLIPS TRUSS HEAD MACHINE SCREW	2
9	4893141	VACUUM HOSE, 2" I.D.	6'
10	4893151	SCREW CLAMP, 1 5/8-2 7/16	1
11	4893161	DOME HINGE	1
12	4893171	DOME PIVOT SPRING	1
13	4893181	SOLUTION TANK PLUG, NEOPRENE	1
14	4893191	DRAIN NOZZLE COUPLING, 1/2" BARB X 1/2" BARB	1
15	4893201	DRAIN HOSE CLIP ASSEMBLY	1
16	4893211	DRAIN HOSE, 5/8" O.D. X 1/8" WALL X 21" LONG	1
17	-----	SOLUTION HOSE, 3/8"	1
18	4893241	HOSE CLAMP, 5/8"	2
19	4893251	HOSE CLAMP, NYLON	1
20	4893261	90° ELBOW, 1/2" MALE NPT X 5/8" BARB	1
21	4893271	90° ELBOW, 1/2" MALE NPT X 3/8" BARB	1
22	4893281	1/8" BACKUP WASHER	8
23	4893291	1/8" BLACK RIVET	8
24	6291481	NSS LOGO LABEL	1
25	4893391	MOTOR HOUSING	1
26	4893381	#8 X 1" PAN HEAD SHEET METAL SCREW	2
27	-----	SPACER, 1/2" OD X .257" ID X 5/16" LONG	2
28	4893411	BRUSH CHAMBER COVER	1
29	4893401	#10 X 1/2 PAN HEAD SHEET METAL SCREW	2
30	4893421	SOLUTION TANK FILTER WITH FRAME	1
31	4893431	LABEL: "BEFORE POURING SOLUTION..."	1
32	4893441	SOLUTION TANK	1
33	4893451	RECOVERY PAIL	2
34	4893461	RECOVERY PAIL HANDLE	2
35	4893471	LID SCREEN ASSEMBLY	2

PLASTIC BODY ASSEMBLY

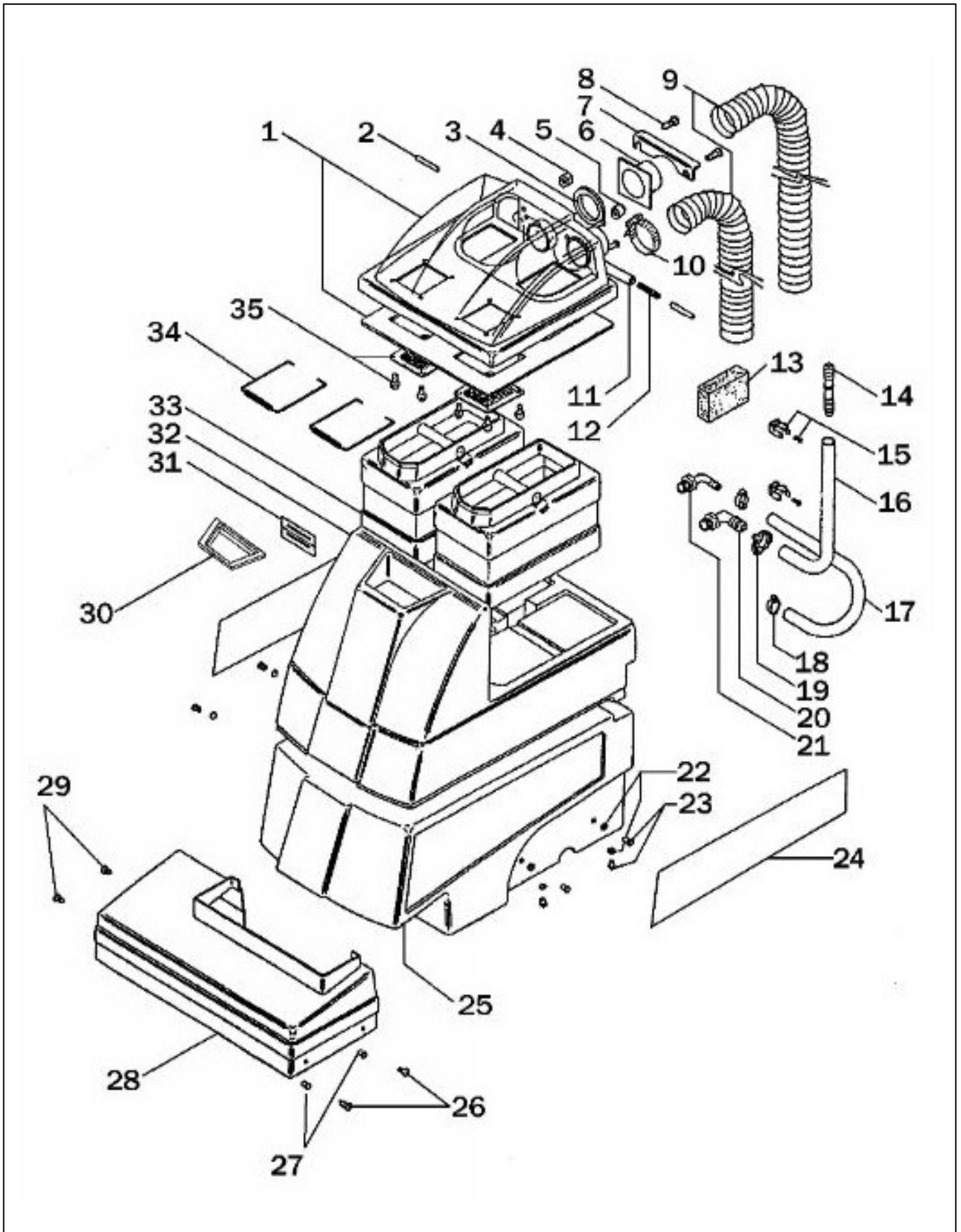

HANDLE ASSEMBLY

<u>ITEM</u>	<u>PART NO.</u>	<u>DESCRIPTION</u>	<u>QTY</u>
1	4896261	50' EXTENSION CORD, YELLOW, WITH FEMALE TWIST LOCK	1
	0396301	TYPE I CORD (CHINA)	1
4	4896291	ON-OFF ROCKER SWITCH, LIGHTED (GREEN)	3
5	4893511	#8 X 1/2 PHILLIPS PAN HEAD SHEET METAL SCREW	14
6	4896301	SWITCH PLATE COVER	1
7	4896311	INDICATOR LIGHT (GREEN)	1
8	4896321	SWITCH/HANDLE LABEL	1
9	4896331	PATENT LABEL	1
10	4892381	STALLION 12SC LABEL	1
11	4896381	HANDLE (BLACK)	1
13	4896401	SERIAL NUMBER COVER	1
14	4896411	VINYL HANDLE GRIP	2
15	4896421	MOMENTARY TOGGLE SWITCH	1
16	4896431	TOGGLE BOOT	1
17	4896441	HANDLE GASKET	1
18	4896451	HANDLE COVER	1
19	4896461	CORD WRAP ASSEMBLY	1
20	4896471	FEMALE 3-C MOLEX	4
21	4896481	WIRE HARNESS, HANDLE-FRAME	1
22	4896491	WIRE HARNESS, POWER CORD TO SWITCHES	1
23	4896501	STRAIN RELIEF	1
25	4897471	CIRCUIT BREAKER RESET LABEL	1
26	4897481	CIRCUIT BREAKER, 3 AMP (115 VAC)	1
	4897491	CIRCUIT BREAKER, 1.5 AMP (250 VAC)	1
27	4897501	CIRCUIT BREAKER FLEX BOOT	1
28	4898141	1" SQUARE CLOSURE PLUG	1
29	4898151	12/3 SJTW YELLOW STUB	1
30	4898161	LABEL, "IMPORTANT: THIS EQUIPMENT..."	1
31	4898821	SPRAY SWITCH	1

HANDLE ASSEMBLY

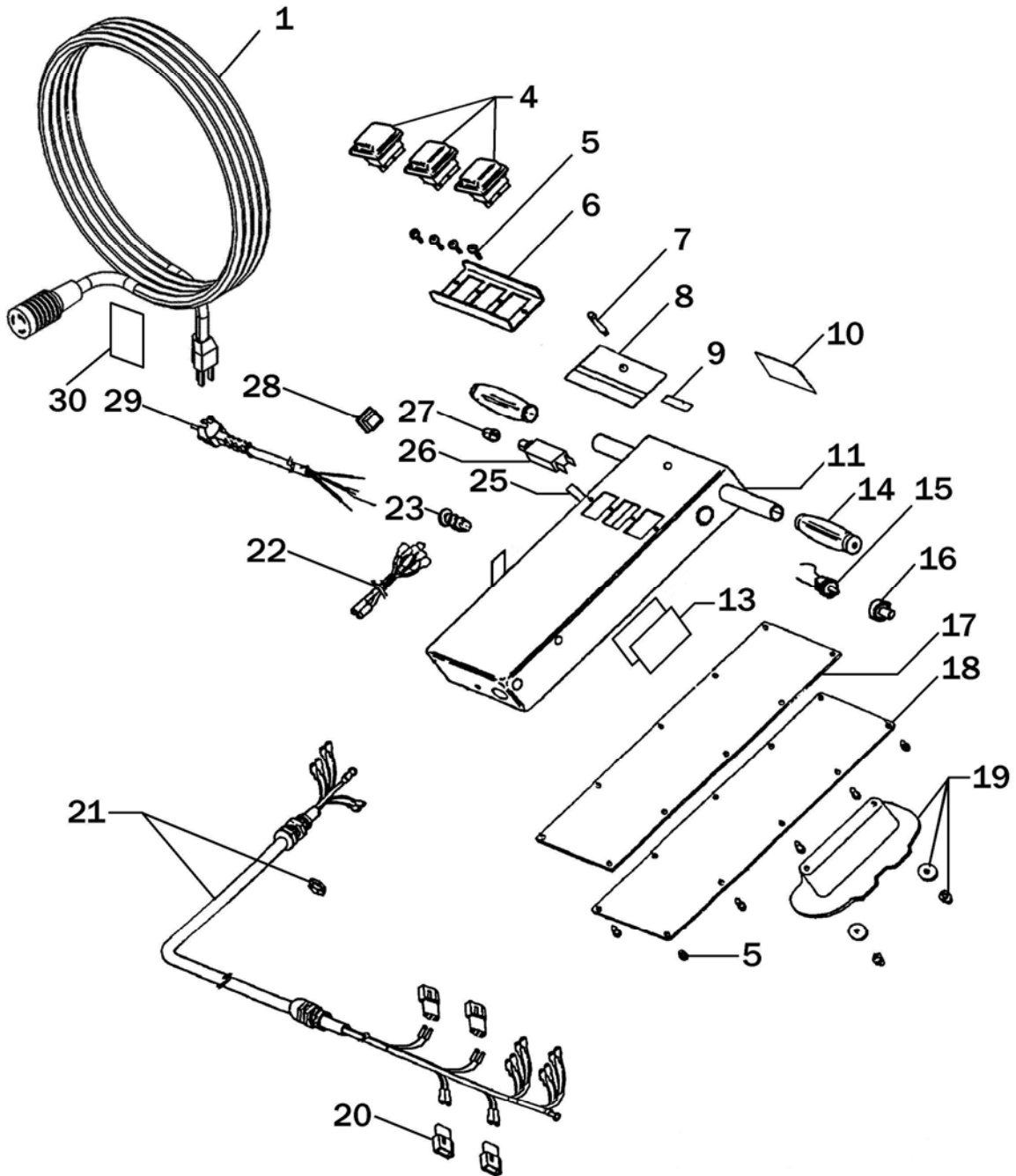

WIRING DIAGRAM

115 VAC / 60 Hz
230 VAC / 50/60 Hz

COLOR CODES	
B	=BLACK
B1	=BLUE
Br	=BROWN
GY	=GREEN/YELLOW
Or	=ORANGE
R	=RED
V	=VOILET
W	=WHITE
Y	=YELLOW

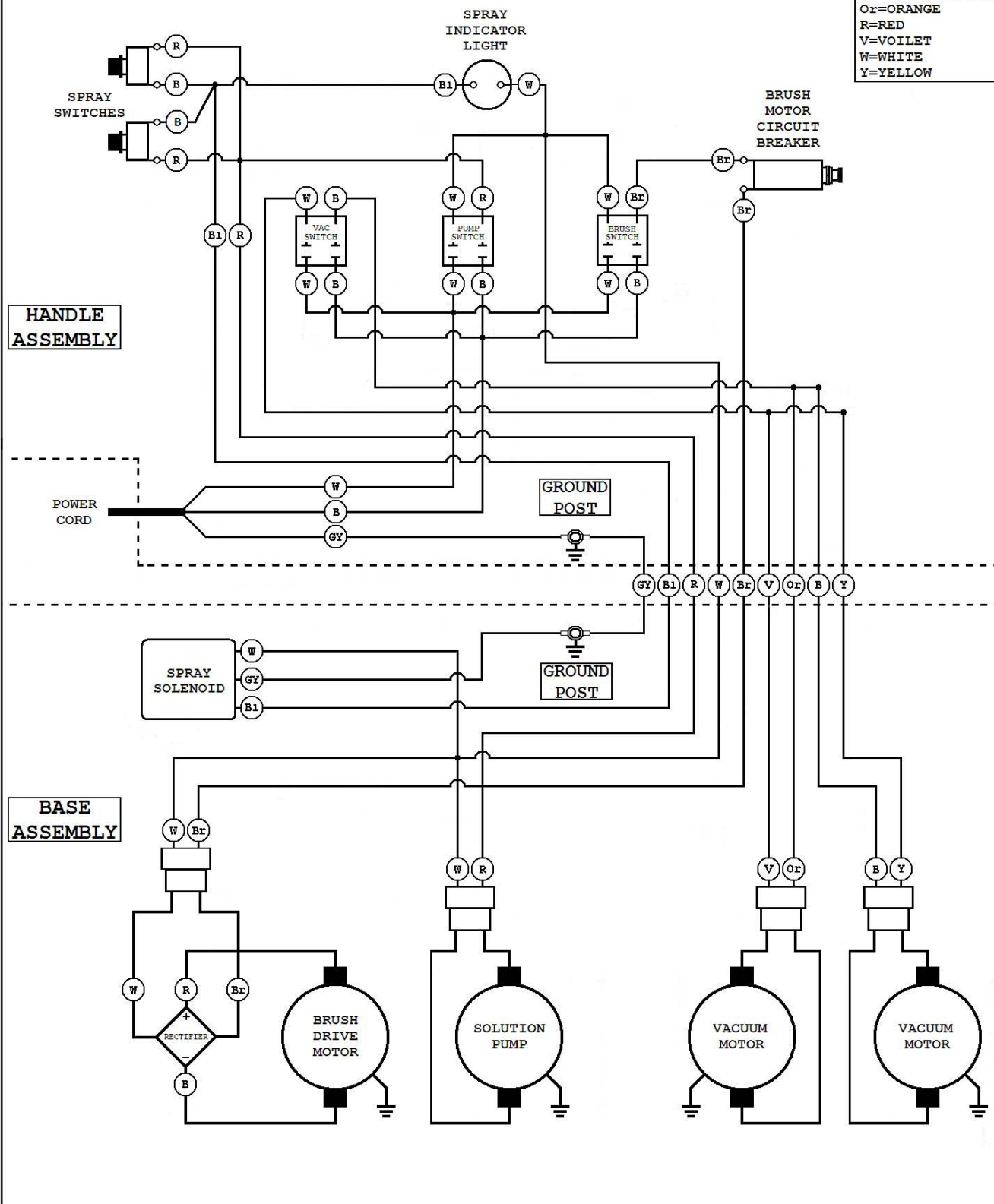

APPENDIX I

BRUSH DRIVE BELT SERVICE AND/OR REPLACEMENT

1. Remove (2) ¼-20 hex screws attaching lower frame to upper frame.
2. Remove (4) #8-32 screws on the sides of the brush chamber cover.
3. Remove (2) spring cover plate assemblies and carefully remove springs from the slide blocks.
4. Loosen (2) ¼-20 hex screws that hold brush motor bracket in place. Push bracket toward the front of the machine to loosen belt.
5. Remove right Open- End and left Pulley- End cover plates.
6. Slide brush assembly and slide blocks out from their guides. Replace worn and defective belt.
7. Reinstall above components. Clean accumulated lint or debris inside the slide block guides and check for wear in the teflon surfaces. Replace if necessary. The slide block washer (item #29, see Brush Chamber Assembly section) must be installed between the slide block guide and inside the divider wall. Adjust tension by moving motor bracket toward the rear. Apply minimum belt tension when the hex bolts are tightened to allow for a smooth vertical brush movement. A belt too loose will cause the belt to skip when brush is applied on the carpet. A belt too tight won't allow for up and down movement.

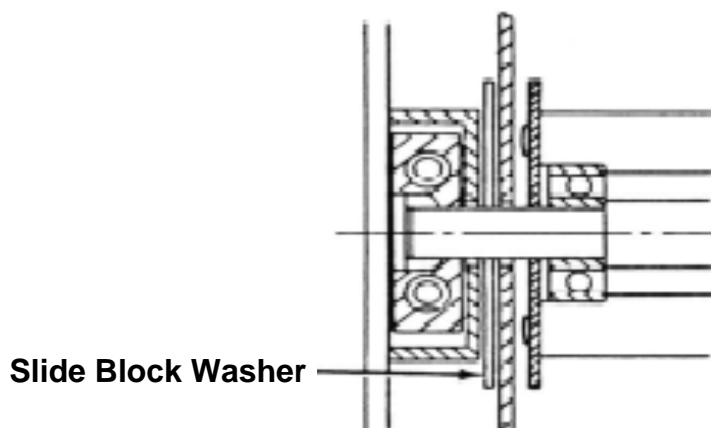

REPLACEMENT OF BRUSH ASSEMBLY AND/OR BEARINGS

1. Follow steps 1 thru 4 of "Brush Drive Belt Service and/or Replacement".
2. Remove slide blocks from the ends of the brush shaft.
3. Remove (4) screws from the string guard. Tap the shaft toward the right open end to remove the bearing.
4. Remove (4) screws from slinger and pull off brush core. Scrape off old sealant build up on the slinger and string guard. It is advisable to replace the two bearings every time the brush is replaced.
5. Reinstall the above component.

CAUTION! Install the shorter step on the shaft end toward the left pulley side. Apply silicon sealant such as GE Silicon auto seal onto the ends of the brush core before reassembling the slinger and string guard.

ACCESSORIES

<u>PART NO.</u>	<u>PART DESCRIPTION</u>
3097849	14" SQUEEGEE WITH BRUSH
4892971	15' VACUUM HOSE WITH ADAPTOR
4892981	1 1/2" HOSE ADAPTOR - WAND END - INCLUDED WITH 4892971
4098021	15' SOLUTION HOSE - LOW PRESSURE - FEMALE / FEMALE QDC
3891581	15' SOLUTION HOSE - LOW PRESSURE - MALE / MALE QDC
3890991	15' SOLUTION HOSE - LOW PRESSURE - FEMALE / MALE QDC
4097111	QUICK CONNECT ADAPTOR - FEMALE / FEMALE
4093251	3 - JET WAND - 12" WIDTH
4097201	2 - JET WAND - 12" WIDTH
4097301	SINGLE JET - 30" LONG STAIR WAND - 9 3/4" WIDTH
4097401	6" STAIR TOOL
4096841	4" UPHOLSTERY TOOL
4096851	3 1/2" DETAIL TOOL
4096871	8" FLATTENED INTERNAL SPRAY CREVICE TOOL
4098101	12" SQUEEGEE WITH WAND
9094030	EXTRACTOR ACCESSORIES ILLUSTRATED PARTS BOOK
4891721	COIL HOSE WITH SPRAY GUN - LOW PRESSURE - FEMALE QDC
4892889	UPHOLSTERY KIT - INCLUDES:
4096841	4" UPHOLSTERY TOOL
4892981	ADAPTOR, 1 1/2" HOSE
2598551	CLEARVIEW HOSE
4098021	15' SOLUTION HOSE - LOW PRESSURE - FEMALE / FEMALE QDC
4892899	DETAIL 3 - JET WAND TOOL KIT - INCLUDES:
4093251	3 - JET WAND - 12" WIDTH
4892971	15' VACUUM HOSE WITH ADAPTOR
4098021	15' SOLUTION HOSE - LOW PRESSURE - FEMALE / FEMALE QDC



NSS® Enterprises, Inc.

3115 Frenchmens Road, Toledo, Ohio 43607
PHONE (419) 531-2121 FAX (419) 531-3761

NSS® Enterprises, Inc. European Distribution Centre
Unit II, Pinfold Trading Estate * 55 Nottingham Road
STAPLEFORD, NOTTINGHAM NG9 8AD ENGLAND U.K.
PHONE: (44) 0115 939 1568 * FAX: (44) 0115 949 0615

NSS Asia Limited Shanghai
501 LiYuan Road, Building A7, Suite 7112
Lu Wan District, Shanhai, China 6137125