

PARTS LIST
WRANGLER 2016 AE, AB, DB

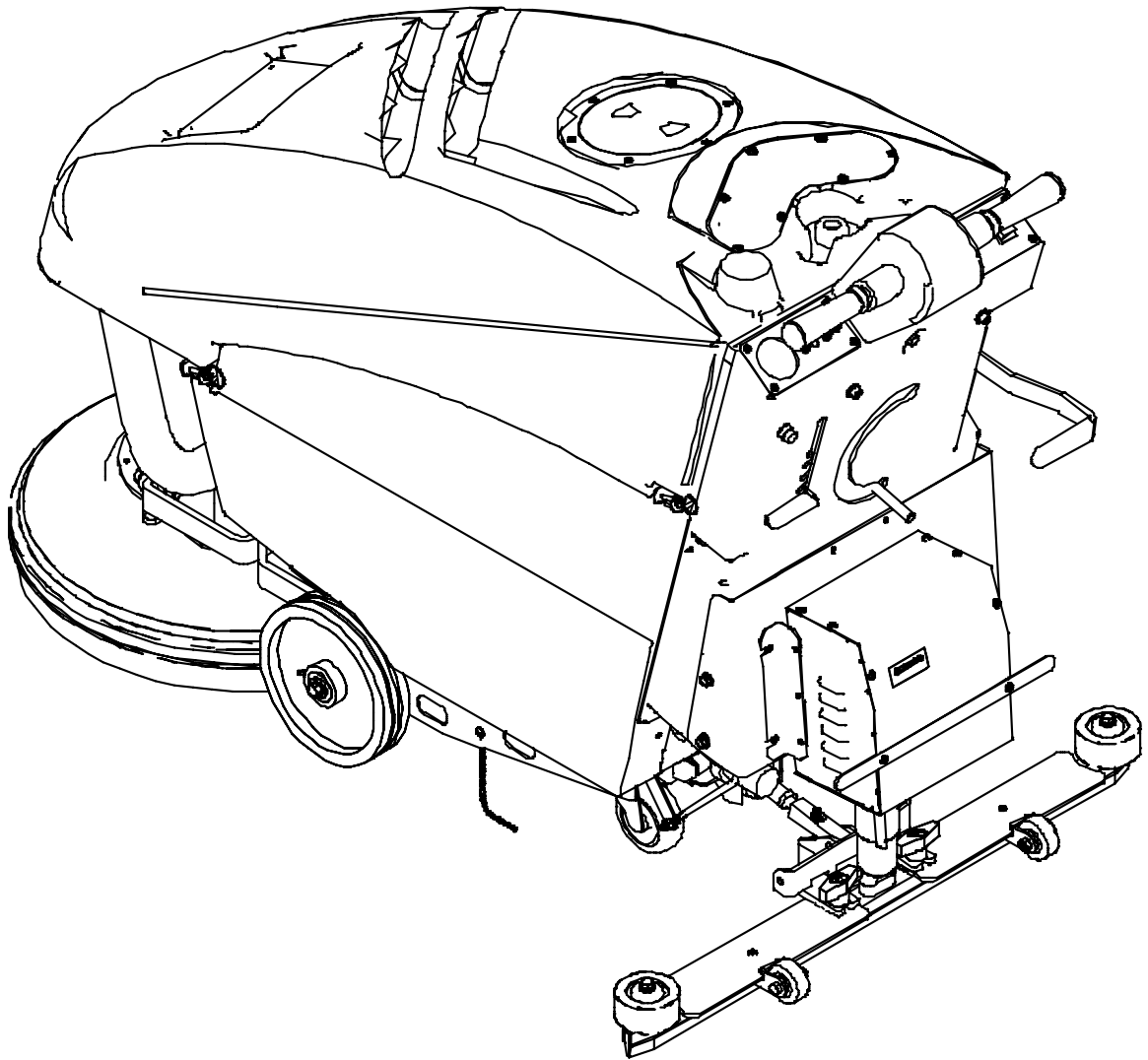

BRUSH HEAD ASSEMBLY

ITEM	PART NO.	DESCRIPTION	QTY
101	2397081	MOTOR HOUSING	1
102	9120610	#10-24 X 5/8 PAN HEAD PHILLIPS THREAD CUTTING SCREW [PACK OF 10]	4
103	2397991	WATER SOLENOID 24 VOLT	1
	2397721	WATER SOLENOID 120 VOLT (USE ON AE MODELS)	1
104	9120910	1/4-20 HEX NUT WITH STAR LOCK WASHER [PACK OF 10]	2
105	2393001	GEAR MOTOR, 3/4 HP, 24 VOLT DC	1
	2393011	GEAR MOTOR, 3/4 HP, 120 VOLT AC (USE ON AE MODELS)	1
106	2690581	1/4 SPADE MALE TERMINAL 12-10 AWG YELLOW	2
107	9122580	1/2-13 X 2 HEX BOLT [PACK OF 1]	2
108	9122450	17/32 I.D. X 1 1/6 O.D. X .074/.121 THICK SAE FLAT WASHER (1/2) [PK 5]	2
109	2397213	DECK SKIRT	1
110	2391941	BALL JOINT	2
111	9122420	1/2 SPLIT LOCK WASHER [PACK OF 5]	2
112	9122700	1/2-20 X 1 HEX BOLT [PACK OF 2]	2
113	2391702	SKIRT BAND	1
114	9120450	#10-24 X 1 ROUND HEAD PHILLIPS MACHINE SCREW [PACK OF 10]	1
115	9120350	#10-24 HEX NUT WITH NY-LOK INSERT [PACK OF 10]	1
116	2391121	BUMPER GUARD	1
117	2393052	CLUTCH CASTING	1
118	9121985	13/32 I.D. X 1 O.D. X .12 THICK SAE FLAT WASHER [PACK OF 1]	1
119	9121520	5/16 SPLIT LOCK WASHER [PACK OF 10]	1
120	9121640	5/16-18 X 3/4 HEX BOLT [PACK OF 5]	1
121	-----	SEE ACCESSORIES PAGE FOR PADS AND BRUSHES	1
122	2892601	20" STRUCTURAL FOAM PAD DRIVER - INCLUDES:	1
122A	5990731	SPRING CLIP PAD HOLDER SET (WHITE) - INCLUDES:	1
122B	9120506	#8 X 5/8 PAN HEAD PHILLIPS SHEET METAL SCREW	3
122A	5990601	LOCK RING DEEP (BLUE)	1
123	2393061	SPACER	1
124	9122220	3/8-16 X 3/4 HEX BOLT [PACK OF 5]	4
125	9122100	3/8 SPLIT LOCK WASHER [PACK OF 10]	4
126	9121980	13/32 I.D. X 1 O.D. X .12 THICK FLAT WASHER (11 GA) [PACK OF 2]	2
127	9121560	5/16-18 X 1/2 HEX BOLT [PACK OF 5]	1
128	9121410	5/16 EXTERNAL STAR LOCK WASHER [PACK OF 10]	1
129	2392276	AXLE, BUMPER WHEEL	1
130	2790281	3" BUMPER WHEEL	1
131	9121390	11/32 I.D. X 11/16 O.D. X .051/.080 THICK SAE FLAT WASHER (5/16) [PK 10]	1
132	9121410	5/16 EXTERNAL STAR LOCK WASHER [PACK OF 10]	1
133	9121560	5/16-18 X 1/2 HEX BOLT [PACK OF 5]	1
134	9121250	1/4-20 X 3/4 HEX HEAD MACHINE SCREW [PACK OF 10]	2
135	2397741	BRACKET, DRAIN HOSE CATCH	1
136	9120930	9/32 I.D. X 5/8 O.D. FLATWASHER - PACK OF 10	2

BRUSH HEAD ASSEMBLY

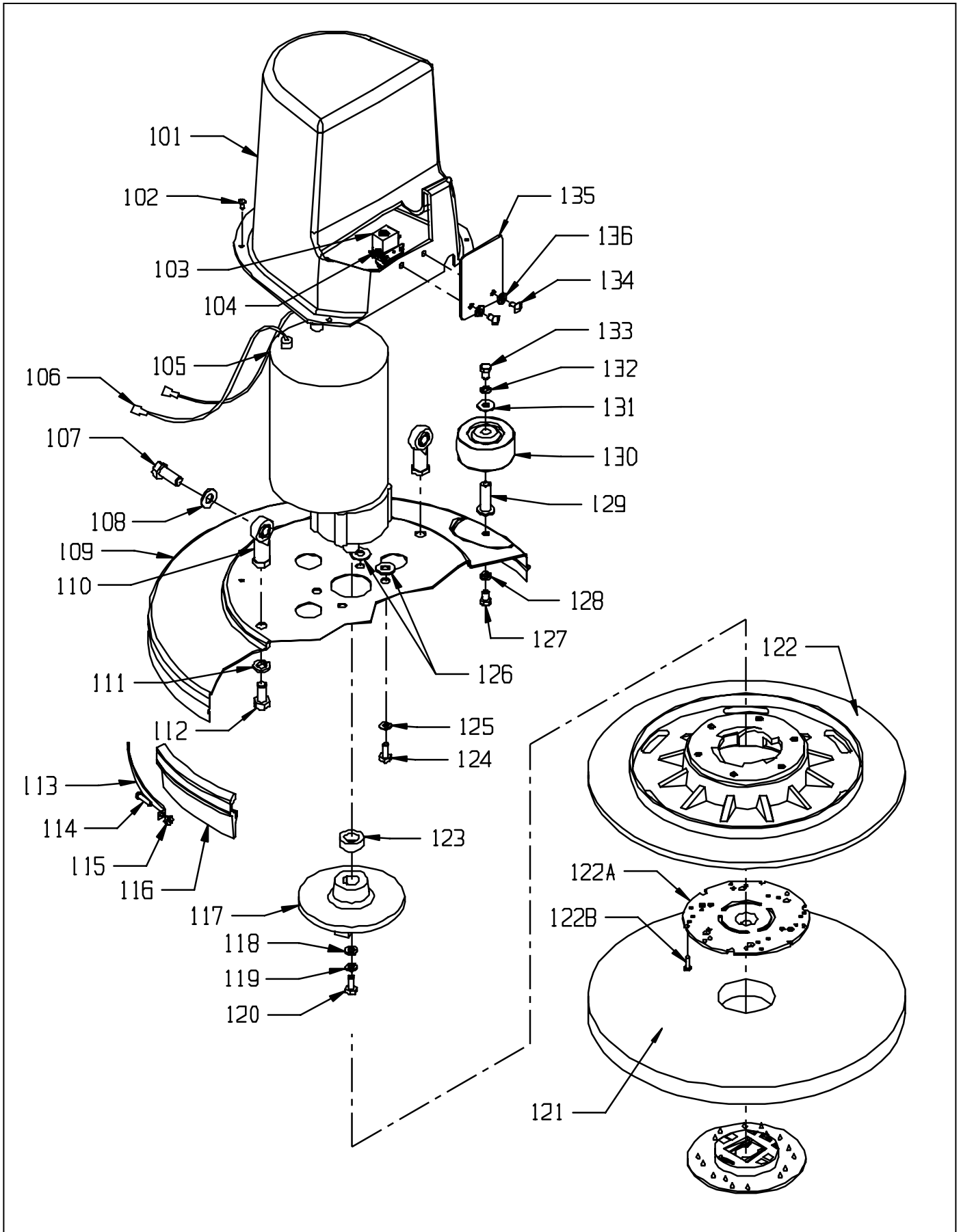

AE, AB FRAME ASSEMBLY

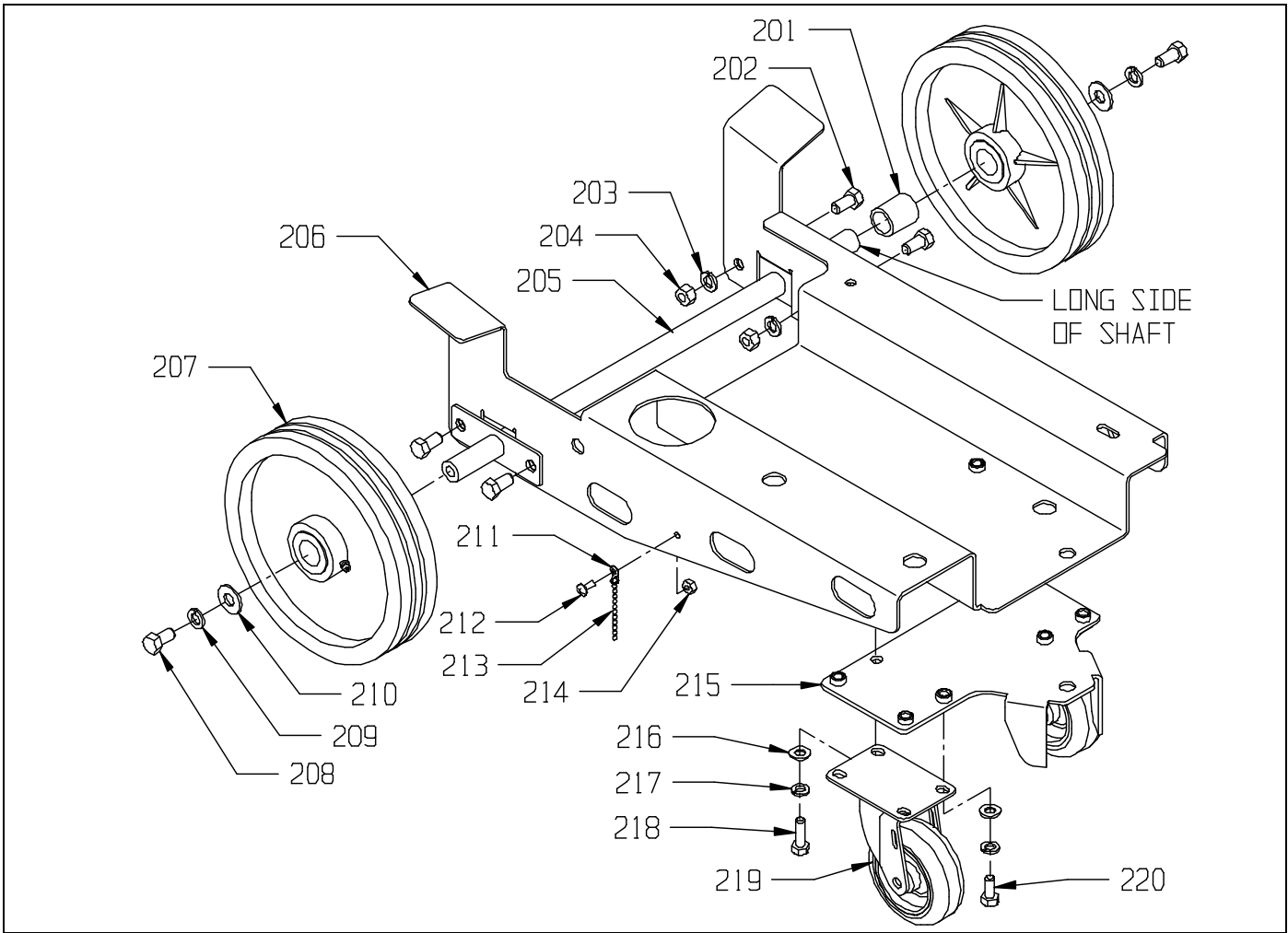

<u>ITEM</u>	<u>PART NO.</u>	<u>DESCRIPTION</u>	<u>QTY</u>
201	7690551	DRIVE CASTING SPACER	1
202	9122220	3/8-16 X 3/4 HEX BOLT [PACK OF 5]	4
203	9122100	3/8 SPLIT LOCK WASHER [PACK OF 10]	4
204	9122000	3/8-16 HEX NUT [PACK OF 10]	4
205	2397311	AXLE	1
206	2398011	FRAME	1
207	2393781	WHEEL, 8" WITH GROOVES	2
	2393681	BEARING FOR WHEEL 2393781 (2 PER WHEEL)	4
208	9122220	3/8-16 X 3/4 HEX BOLT [PACK OF 5]	2
209	9122100	3/8 SPLIT LOCK WASHER [PACK OF 10]	2
210	9121980	7/16 I.D. X 1 O.D. X .075/.080 THICK SAE FLAT WASHER (3/8) [PACK OF 2]	2
211	6491871	END COUPLING ROUND BEAD CHAIN	1
212	9120510	#10-24 X 1/2 TRUSS HEAD PHILLIPS SCREW [PACK OF 10]	1
213	6491860	ROUND BEAD CHAIN (CUT TO 6")	.5'
214	9120360	#10-24 HEX NUT WITH STAR LOCK WASHER [PACK OF 10]	1
215	2398021	CASTER MOUNT PLATE	1
216	9121390	11/32 I.D. X 11/16 O.D. X .051/.080 THICK FLAT WASHER (5/16) [PACK OF 10]	8
217	9121520	5/16 SPLIT LOCK WASHER [PACK OF 10]	8
218	9121680	5/16-18 X 1 HEX BOLT [PACK OF 5]	2
219	2398031	CASTER 3 1/2 WHEEL SWIVEL TOP - INCLUDES:	2
	2398211	WHEEL, 3 1/2 PERFORMA RUBBER	1
220	9121640	5/16-18 X 3/4 HEX BOLT [PACK OF 5]	6

DB FRAME ASSEMBLY

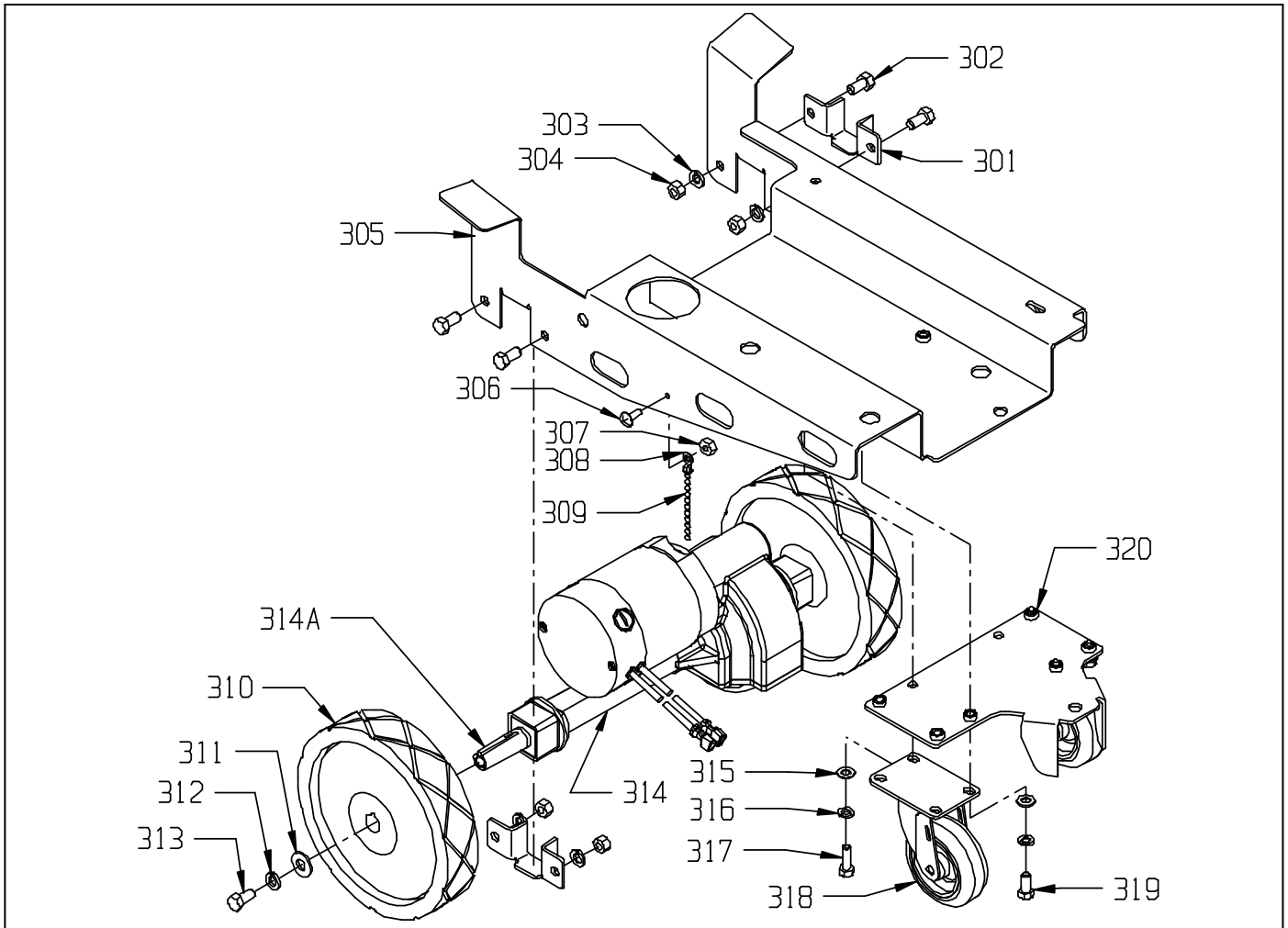

<u>ITEM</u>	<u>PART NO.</u>	<u>DESCRIPTION</u>	<u>QTY</u>
301	2397111	TRANSAXLE BRACKET	2
302	9122220	3/8-16 X 3/4 HEX BOLT [PACK OF 5]	4
303	9122100	3/8 SPLIT LOCK WASHER [PACK OF 10]	4
304	9122000	3/8-16 HEX NUT [PACK OF 10]	4
305	2398011	FRAME	1
306	9120510	#10-24 X 1/2 TRUSS HEAD PHILLIPS SCREW [PACK OF 10]	1
307	9120360	#10-24 HEX NUT WITH STAR LOCK WASHER [PACK OF 10]	1
308	6491871	END COUPLING ROUND BEAD CHAIN	1
309	6491860	ROUND BEAD CHAIN (CUT TO 6")	.5'
310	2396351	WHEEL - DRIVE, 8 X 2	2
311	9121980	7/16 I.D. X 1 O.D. X .075/.080 THICK SAE FLAT WASHER (3/8) [PACK OF 2]	2
312	9122100	3/8 SPLIT LOCK WASHER [PACK OF 10]	2
313	9122220	3/8-16 X 3/4 HEX BOLT [PACK OF 5]	2
314	2393901	TRANSAXLE	1
314A	9120826	3/16 SQUARE X 1 1/4" LONG KEY [PACK OF 2]	2
	2693181	BRUSH KIT (SET OF 4 FOR TRANSAXLE MOTOR)	1
315	9121390	11/32 I.D. X 11/16 O.D. X .051/.080 THICK FLAT WASHER (5/16) [PACK OF 10]	8
316	9121520	5/16 SPLIT LOCK WASHER [PACK OF 10]	8
317	9121680	5/16-18 X 1 HEX BOLT [PACK OF 5]	2
318	2398031	CASTER 3 1/2 WHEEL SWIVEL TOP - INCLUDES	2
	2398211	WHEEL, 3 1/2 PERFORMA RUBBER	1
319	9121640	5/16-18 X 3/4 HEX BOLT [PACK OF 5]	6
320	2398021	CASTER MOUNT PLATE	1

SOLUTION TANK TO FRAME ASSEMBLY

ITEM	PART NO.	DESCRIPTION	QTY
401	7691891	NSS LOGO LABEL - 3.5 X 20	1
402	2393951	90° ELBOW, 1/2 M-NPT X 1/2 BARB	1
403	9122507	1/2-13 HEX NUT WITH NY-LOK INSERT [PACK OF 1]	2
404	2397303	DECK LIFT	1
405	2398011	FRAME	1
406	8791180	VINYL HOSE 1/2 I.D. X 3/4 O.D. (11 1/2" LENGTH)	.96'
407	2495161	FITTING 1/4 NPT X 1/2 BARB STRAIGHT	1
408	9121390	11/32 I.D. X 11/16 O.D. X .051/.080 THICK SAE FLAT WASHER (5/16) [PK 10]	2
409	9121520	5/16 SPLIT LOCK WASHER [PACK OF 10]	4
410	9121580	5/16-18 X 3/4 BUTTON HEAD CAP SCREW [PACK OF 5]	4
411	2397981	VALVE LEVER LARGE PIVOT HOLE	1
412	2791281	BUSHING SPACER	1
413	9120900	1/4-20 HEX NUT WITH NY-LOK INSERT [PACK OF 10]	2
414	2393281	90° ELBOW, 1/4 NPT X 1/4 NPT	1
415	3393551	INLINE CANISTER STRAINER (INCLUDES)	1
	3393611	STRAINER ELEMENT	1
	3394559	KIT, BOWL & GASKET (INCLUDES)	1
	3393621	GASKET	1
	3392731	BOWL	1
416	2495151	FITTING, ELL 1/2 BARB X 1/4 NPT – NYLON	1
417	8791180	VINYL HOSE 1/2 I.D. X 3/4 O.D. (37" LENGTH)	2.08'
418	2397961	MANUAL SOLUTION VALVE, STEEL STEM	1
419	2397971	2016 VALVE BRACKET	1
420	2391181	GRIP, VALVE LEVER	1
421	2397191	HANDLE SOLUTION VALVE	1
422	9122507	1/2-13 HEX NUT WITH NY-LOK INSERT [PACK OF 1]	2
423	2790751	BUSHING SPACER	2
424	9122450	17/32 I.D. X 1 1/16 O.D. X .074/.121 THICK SAE FLAT WASHER (1/2) [PK 5]	4
425	9122550	1/2-13 X 2 HEX BOLT [PACK OF 1]	2
426	3390661	TUBBING CONTROL VALVE	1
427	8791070	VINYL HOSE, 3/8 I.D. X 1/2 O.D. (30" LENGTH)	2.5'
428	2397551	FITTING 1/4 NPT X 3/8 BARB	1
429	2391771	90° HOSE BARB 3/4 I.D. X 1/2 NPT NYLON	1
430	9121210	1/4-20 X 5/8 HEX BOLT [PACK OF 10]	4
431	9120880	1/4 SPLIT LOCK WASHER [PACK OF 10]	4
432	9120930	9/32 I.D. X 5/8 O.D. X .051/.080 THICK WASHER (1/4) [PACK OF 10]	4
433	2397611	HINGE BRACKET	2
434	2393831	LABEL, BATTERY CONNECTIONS	1
435	2397541	BAG RING	1
436	2397531	SOLUTION INLET FILTER	1
437	9120205	#8 X 1/2 PAN HEAD PHILLIPS SHEET METAL SCREW [PACK OF 3]	2
438	2397071	SOLUTION TANK	1
439	3394141	OBC WARNING LABEL	1

SOLUTION TANK TO FRAME ASSEMBLY

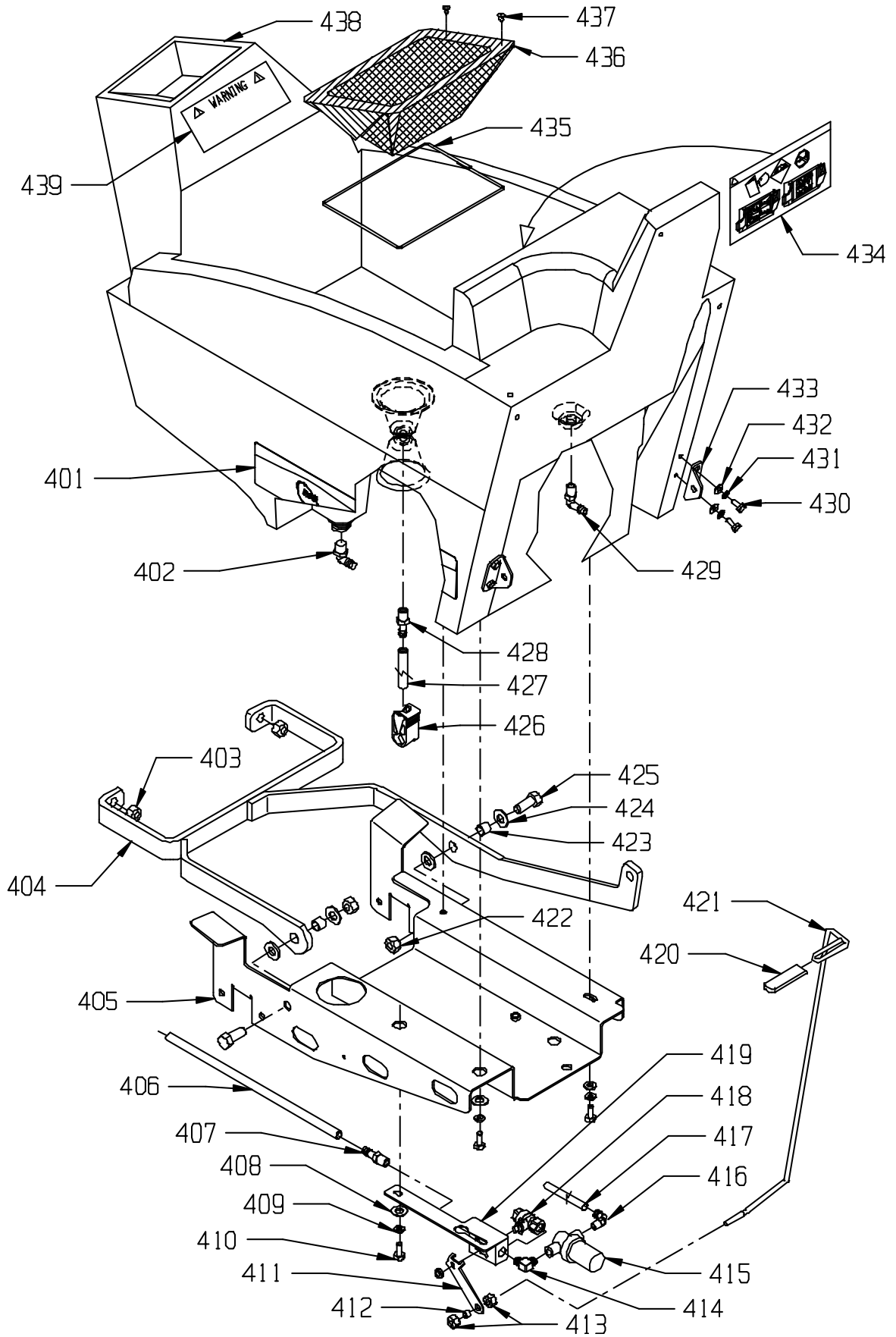

BRUSH LIFT ASSEMBLY

ITEM	PART NO.	DESCRIPTION	QTY
501	9121960	3/8 EXTERNAL STAR LOCK WASHER [PACK OF 10]	1
502	9122030	3/8-16 X 3/4 BUTTON HEAD SOCKET SCREW [PACK OF 2]	1
503	2694261	CABLE	1
504	2391771	90° HOSE BARB 3/4 I.D. X 1/2 NPT NYLON	1
505	2397291	BRACKET DECK LIFT HANDLE	1
506	9121383	5/16-18 X 1 1/4 SET SCREW [PACK OF 1]	1
507	9121410	5/16 EXTERNAL STAR LOCK WASHER [PACK OF 10]	3
508	2397331	DECK LIFT HANDLE GRIP	1
509	2397281	HANDLE DECK LIFT	1
510	9121640	5/16-18 X 3/4 HEX BOLT [PACK OF 5]	2
511	2397303	DECK LIFT	1
512	9122260	3/8-16 X 1 HEX BOLT [PACK OF 2]	1
513	8791030	VINYL HOSE, 3/4" I.D. X 1" O.D. 1/8 THICK (38" LENGTH)	3.2'
514	9120540	#10-24 X 1/2 FLAT HEAD PHILLIPS MACHINE SCREW [PACK OF 10]	1
515	9120330	#10 EXTERNAL STAR LOCK WASHER [PACK OF 10]	1
516	2397271	UNIVERSAL MOUNTING STRAP	1
517	2397421	SOLUTION GAUGE	1
518	9122100	3/8 SPLIT LOCK WASHER [PACK OF 10]	1
519	9122030	3/8-16 X 3/4 BUTTON HEAD SOCKET SCREW [PACK OF 2]	1
520	9121160	1/4-20 X 3/8 HEX BOLT [PACK OF 10]	1
521	9120880	1/4 SPLIT LOCK WASHER [PACK OF 10]	1
522	9120930	9/32 I.D. X 5/8 O.D. X .051/.080 THICK SAE FLAT WASHER (1/4) [PK OF 10]	1
523	9121440	5/16-18 WING NUT [PACK OF 2]	1
524	9122010	3/8-24 HEX NUT [PACK OF 5]	1
525	2691811	SHORT LIFT ROD, BRUSH	1
526	2691831	HOUSING - SPRING, RETAINER	1
527	2691841	SPRING, BRUSH PRESSURE	1
528	9122140	3/8-16 HEX NUT WITH NY-LOK INSERT [PACK OF 5]	1
529	2691821	HOUSING - SPRING, BRUSH LIFT	1
530	9122000	3/8-16 HEX NUT [PACK OF 10]	1
531	2397581	LIFT ROD 13"	1
532	9122010	3/8-24 HEX NUT [PACK OF 5]	1
533	4490531	3/8" ROD END	2
534	2397061	RECOVERY TANK	1
535	2391963	CAST IRON WEIGHT (USE ON AE MODELS)	1
536	9997550	VELCRO HOOK (USE ON AE MODELS)	1'
537	9997560	VELCRO LOOP (USE ON AE MODELS)	1'
538	2392761	WARNING TAG - BATTERY TERMINAL	1
539	3390361	BATTERY, WET, 6 VOLT, 235 AMP/HOUR	4
	6393651	BATTERY WET, 12 VOLT, 130 AMP/HOUR	2
	2392731	BATTERY, GEL 12 VOLT 100 AMP/HOUR	2
540	6496031	BATTERY BLOCK	2
541	2397071	SOLUTION TANK	1

BRUSH LIFT ASSEMBLY

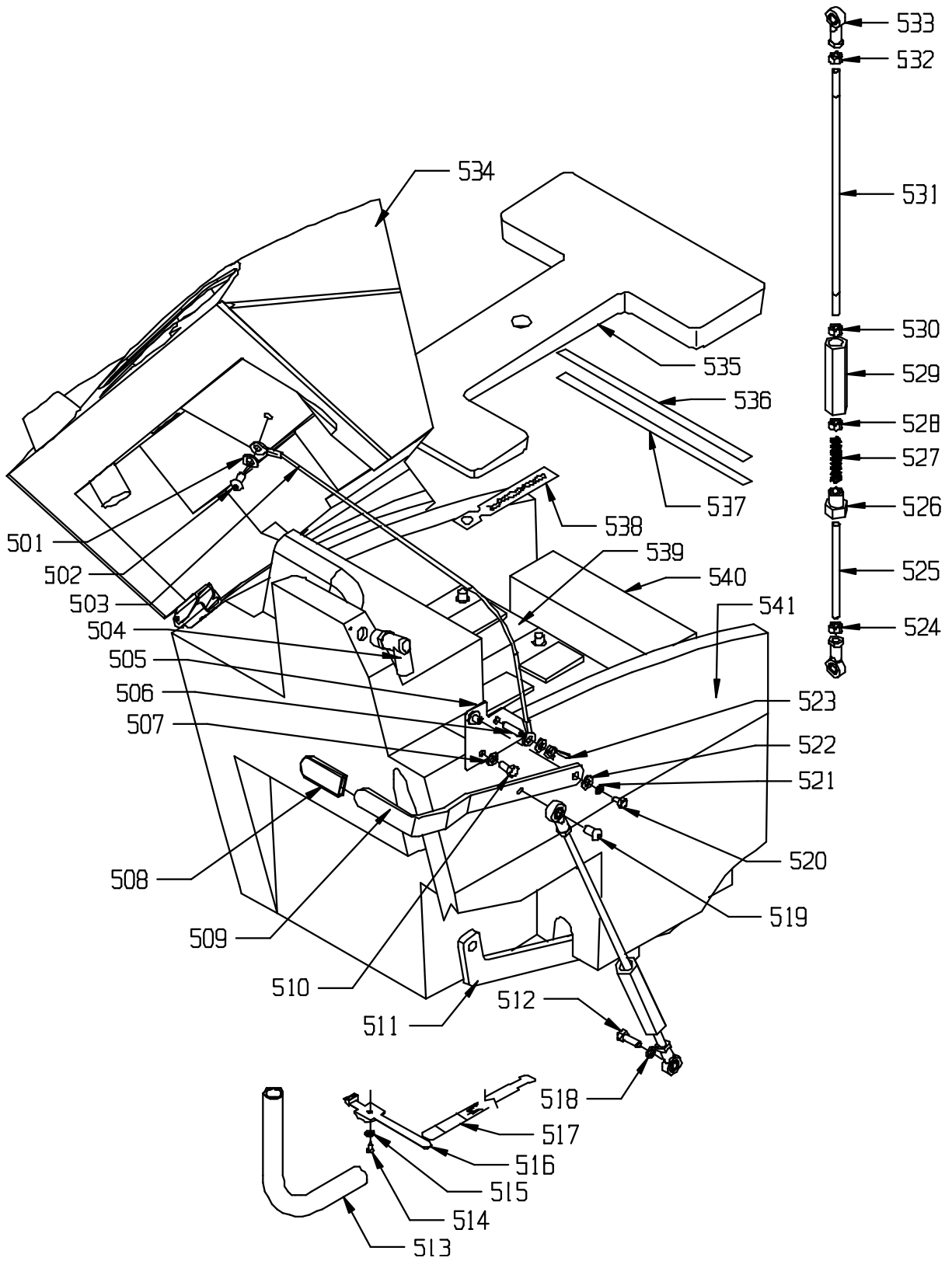

RECOVERY TANK ASSEMBLY

ITEM	PART NO.	DESCRIPTION	QTY
601	2397671	CLIP, TIE STRAP	1
602	9120330	#10 EXTERNAL STAR LOCK WASHER [PACK OF 10]	1
603	9120510	#10-24 X 1/2 TRUSS HEAD PHILLIPS MACHINE SCREW [PACK OF 10]	1
604	9123000	11" LONG WIRE TIE [PACK OF 5]	1
605	7691261	EXHAUST MUFFLER TUBE	1
606	9123000	11" LONG WIRE TIE [PACK OF 5]	1
607	2397691	VAC MOTOR HOSE EXHAUST - 18" LONG	1
608	4495441	HOSE CLAMP - 1 9/16 TO 2 1/2	1
609	4495441	HOSE CLAMP - 1 9/16 TO 2 1/2	1
610	7695341	DRAIN HOSE, RECOVERY TANK	1
611	2397031	LOWER HINGE BRACKET	2
612	2393931	CLEVIS PIN, Ø 3/16" X 1 3/4" LONG	2
613	9121570	5/16-18 X 1/2 BUTTON SOCKET HEAD CAP SCREW [PACK OF 5]	5
614	9121410	5/16 EXTERNAL STAR LOCK WASHER [PACK OF 10]	5
615	2397021	UPPER HINGE BRACKET	2
616	5490161	FULLY INSULATED FEMALE TERMINAL 14-16 AWG	2
617	2395571	MOTOR, VAC 24 VOLT - 3 STAGE	1
	2397571	CARBON BRUSH REPLACEMENT - 24 VOLT	2
	2391071	MOTOR, VAC 120 VOLT - 2 STAGE (USE ON AE MODELS)	1
	2392581	CARBON BRUSH REPLACEMENT - 120 VOLT	2
618	9120900	1/4-20 HEX NUT WITH NY-LOK INSERT [PACK OF 10]	3
619	9120930	9/32 I.D. X 5/8 O.D. X .051/.080 THICK SAE FLAT WASHER (1/4) [PK 10]	3
620	4690101	VAC MOTOR / FLOAT GASKET	1
621	9121363	1/4-20 X 4 1/2 FULL THREADED STUD [PACK OF 2]	3
622	2690591	SQUEEGEE VAC HOSE WITH CUFFS	1
623	4892671	HOSE CLAMP - 1 1/16 TO 2	1
624	2391541	FLOAT SCREEN ASSEMBLY	1
625	8891100	GASKET MATERIAL 1/2" X 1" (26" LENGTH)	2.2'
626	4894461	RUBBER STOP (USED ON AB, DB MODELS)	1
627	9121010	1/4-20 X 3/4 TRUSS HEAD PHILLIPS MACHINE SCREW [PACK OF 5]	1
628	2397591	VAC FILTER	1
629	2397441	VAC PLATE GASKET	1
630	2393511	IDENTIFIER LABEL - WRANGLER 2016 DB	1
	2393521	IDENTIFIER LABEL - WRANGLER 2016 AB	1
	2393531	IDENTIFIER LABEL - WRANGLER 2016 AE	1
631	2397411	VAC PLATE	1
632	5392401	WARNING - FIRE LABEL	1
633	9120330	#10 EXTERNAL STAR LOCK WASHER [PACK OF 10]	7
634	9120510	#10-24 X 1/2 TRUSS HEAD PHILLIPS MACHINE SCREW [PACK OF 10]	7
635	2690889	RECOVERY TANK LID AND GASKET ASSEMBLY - INCLUDES:	1
635A	2690881	RECOVERY TANK LID ASSEMBLY - INCLUDES:	1
635A1	2690921	BLACK RING, RECOVERY TANK	1
635A2	9120205	#8 X 1/2 PAN HEAD PHILLIPS SHEET METAL SCREW [PACK OF 3]	1
635A3	2690931	LID CHAIN	1
635A4	2690911	LID - CLEAR	1
635B	2690891	RECOVER TANK LID GASKET	1
636	9120205	#8 X 1/2 PAN HEAD PHILLIPS SHEET METAL SCREW [PACK OF 3]	5
637	9120450	#10-24 X 1 ROUND HEAD PHILLIPS MACHINE SCREW [PACK OF 10]	1
638	9120360	#10-24 HEX NUT WITH STAR LOCK WASHER [PACK OF 10]	1
639	2397061	RECOVERY TANK	1

RECOVERY TANK ASSEMBLY

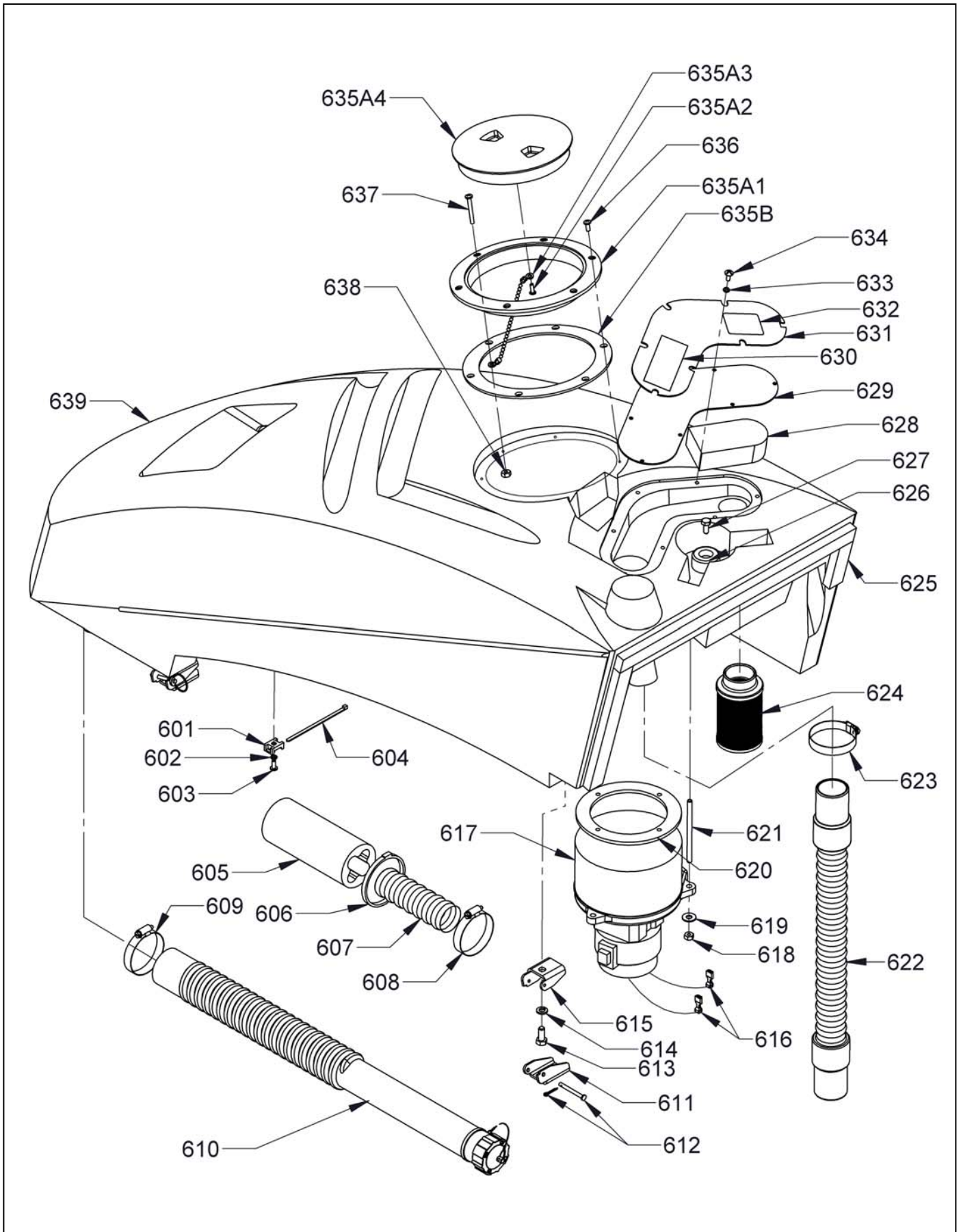

AE HANDLE ASSEMBLY

ITEM	PART NO.	DESCRIPTION	QTY
701	2397771	PLUG, 2" HOLE	1
702	9120205	#8 X 1/2 PAN HEAD PHILLIPS SHEET METAL SCREW [PACK OF 3]	8
703	2397321	DASH PLATE – LEFT	1
704	9121430	5/16-18 HEX NUT WITH NY-LOK INSERT [PACK OF 5]	2
705	2397731	WIRE DIAGRAM LABEL - ELECTRIC 120 VOLT	1
706	2397783	REAR PANEL	1
707	9121430	5/16-18 THIN HEX NUT WITH NY-LOK INSERT [PACK OF 5]	1
708	9121390	11/32 I.D. X 11/16 O.D. X .051/.080 THICK SAE FLAT WASHER (5/16) [PACK OF 10]	2
709	2397141	SQUEEGEE LIFT HANDLE BRACKET	1
710	9121640	5/16-18 X 3/4 HEX BOLT [PACK OF 5]	1
711	9121990	5/16-18 HEX JAM NUT [PACK OF 10]	1
712	2397131	SQUEEGEE LIFT HANDLE	1
713	2397601	GRIP, SQUEEGEE LIFT HANDLE	1
714	9121210	1/4-20 X 5/8 HEX BOLT [PACK OF 10]	1
715	9120880	1/4 SPLIT LOCK WASHER [PACK OF 10]	1
716	4490561	INSULATED STANDOFF	1
717	9120690	#10-32 HEX NUT WITH STAR LOCK WASHER [PACK OF 10]	1
718	5492741	RECTIFIER	1
719	9121430	5/16-18 HEX NUT WITH NY-LOK INSERT [PACK OF 5]	2
720	2397611	HINGE BRACKET	2
721	9121600	5/16-18 X 5/8 HEX BOLT [PACK OF 5]	2
722	4990661	75' POWER CORD, 12-3 WITH TWIST LOCK	1
	5592081	FEMALE TWIST LOCK [REPLACEMENT PART]	1
723	9120930	9/32 I.D. X 5/8 O.D. X .051/.080 THICK SAE FLAT WASHER (1/4) [PACK OF 10]	1
724	9120970	1/4 EXTERNAL STAR LOCK WASHER [PACK OF 10]	1
725	9120430	#10-24 X 3/4 ROUND HEAD PHILLIPS MACHINE SCREW [PACK OF 10]	1
726	9121170	1/4-20 X 1/2 HEX BOLT [PACK OF 10]	1
727	2495301	SQUEEGEE LIFT CABLE	1
728	9120205	#8 X 1/2 PAN HEAD PHILLIPS SHEET METAL SCREW [PACK OF 3]	4
729	9120370	7/32 I.D. X 1/2 O.D. X .032/.065 THICK SAE FLAT WASHER (#10) [PACK OF 10]	4
730	2397381	HANDLE NET	1
731	9120910	1/4-20 HEX NUT WITH STAR LOCK WASHER [PACK OF 10]	2
732	9120930	9/32 I.D. X 5/8 O.D. X .051/.080 THICK SAE FLAT WASHER (1/4) [PACK OF 10]	2
733	2398191	LABEL - MULTI COLOR KIT	1
734	9121390	11/32 I.D. X 11/16 O.D. X .051/.080 THICK SAE FLAT WASHER (5/16) [PACK OF 10]	2
735	9121520	5/16 SPLIT LOCK WASHER [PACK OF 10]	2
736	9121720	5/16-18 X 1 1/4 FULL THREADED HEX HEAD BOLT [PACK OF 2]	2
737	2391461	PIVOT SPACER	2
738	2397651	BRACKET, DECK HEIGHT	1
739	9121470	5/16-18 X 1 FLAT HEAD PHILLIPS MACHINE SCREW [PACK OF 5]	2
740	9121370	5/16-18 X 3 1/4 HEX BOLT [PACK OF 2]	1
741	9121885	5/16-18 X 1 SOCKET HEAD CAP SCREW [PACK OF 2]	2
742	9121390	11/32 I.D. X 11/16 O.D. X .051/.080 THICK SAE FLAT WASHER (5/16) [PACK OF 10]	3
743	5095501	CORD CLAMP	1
744	2397711	STUB CORD WITH MALE TWIST LOCK - 120V	1
745	5091671	STRAIN RELIEF – METAL	1
746	5390261	STRAIN RELIEF NUT	1
747	2397091	HANDLE, AB AND AE MODELS	1
748	3392901	HANDLE GRIP	2
749	2397481	DASH PLATE RIGHT AE MODELS	1
750	0693141	RUBBER SWITCH BOOT	2
751	0691851	1/2 INTERNAL STAR LOCK WASHER	2
752	2792041	SWITCH, TOGGLE [VAC & BRUSH]	2
753	2392201	CIRCUIT BREAKER - 120 VOLT	2
754	2397371	HANDLE SPACER	1
755	5092511	BUTTON – PLUG	1
756	3393591	STRAINER LOCATION LABEL	1
757	5092511	HOLE PLUG	1

AE HANDLE ASSEMBLY

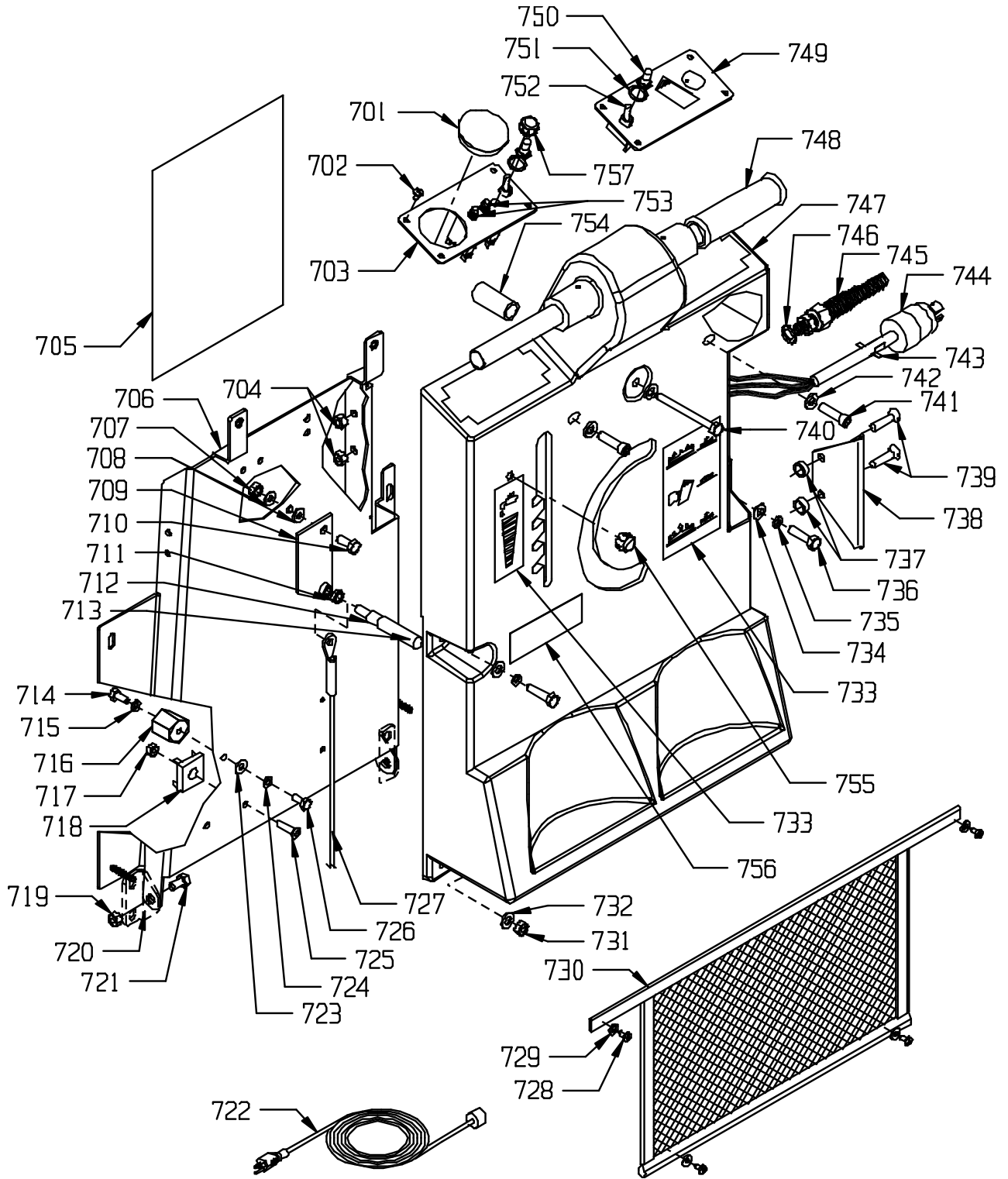

AB, DB REAR PANEL ASSEMBLY

ITEM	PART NO.	DESCRIPTION	QTY.
801	2397371	HANDLE SPACER	1
802	2397091	HANDLE, AB AND AE	1
	2397171	HANDLE, DB	1
803	2393711	WIRE LABEL AB (12V 130AH BATTERIES)	1
	2393801	WIRE LABEL AB (6V 235AH BATTERIES)	1
	2393811	WIRE LABEL DB	1
804	9121390	11/32 I.D. X 11/16 O.D. X .051/.080 THICK SAE FLAT WASHER (5/16) [PACK OF 10]	2
805	9121520	5/16 SPLIT LOCK WASHER [PACK OF 10]	2
806	9121720	5/16-18 X 1 1/4 FULL THREADED HEX HEAD BOLT [PACK OF 2]	2
807	9120930	9/32 I.D. X 5/8 O.D. X .051/.080 THICK SAE FLAT WASHER (1/4) [PACK OF 10]	2
808	9120910	1/4-20 HEX NUT WITH STAR LOCK WASHER [PACK OF 10]	2
809	4894071	CORD CLAMP (USED HERE ON AB MODELS WITH 1392191 CHARGER ONLY)	1
810	9121390	11/32 I.D. X 11/16 O.D. X .051/.080 THICK SAE FLAT WASHER (5/16) [PACK OF 10]	1
811	9121430	5/16-18 THIN HEX NUT WITH NY-LOK INSERT [PACK OF 5]	1
812	2694031	STAND OFF, SPEED CONTROL COVER (USED ON DB ONLY)	2
813	2694021	COVER, SPEED CONTROL (USED ON DB ONLY)	1
814	9120020	#6-32 HEX NUT WITH STAR LOCK WASHER [PACK OF 10] (USED ON DB ONLY)	2
815	2490821	SPEED CONTROL (USED ON DB ONLY)	1
816	9120910	1/4-20 HEX NUT WITH STAR LOCK WASHER [PACK OF 10]	4
817	9120930	9/32 I.D. X 5/8 O.D. X .051/.080 THICK SAE FLAT WASHER (1/4) [PACK OF 10]	4
818	2792241	SILICON RECTIFIER (USED ON DB ONLY)	2
819	2391351	CONTACTOR, 24 VOLT	2
820	9121210	1/4-20 X 5/8 HEX BOLT [PACK OF 10]	1
821	9120880	1/4 SPLIT LOCK WASHER [PACK OF 10]	1
822	4490561	INSULATED STANDOFF	1
823	9121430	5/16-18 HEX NUT WITH NY-LOK INSERT [PACK OF 5]	2
824	2397611	HINGE BRACKET	2
825	9121600	5/16-18 X 5/8 HEX BOLT [PACK OF 5]	2
826	9120970	1/4 EXTERNAL STAR LOCK WASHER [PACK OF 10]	1
827	9121170	1/4-20 X 1/2 HEX BOLT [PACK OF 10]	1
828	9121210	1/4-20 X 5/8 HEX BOLT [PACK OF 10]	4
829	2495301	Y SQUEEGEE LIFT CABLE 25"/63.5 cm	1
830	2397601	GRIP, SQUEEGEE LIFT HANDLE	1
831	2397131	SQUEEGEE LIFT HANDLE	1
832	9121990	3/8-16 HEX JAM NUT [PACK OF 10]	1
833	9121640	5/16-18 X 3/4 HEX BOLT [PACK OF 5]	1
834	2397141	SQUEEGEE LIFT HANDLE BRACKET	1
835	9121390	11/32 I.D. X 11/16 O.D. X .051/.080 THICK SAE FLAT WASHER (5/16) [PACK OF 10]	1
836	9121430	5/16-18 HEX NUT WITH NY-LOK INSERT [PACK OF 5]	2
837	2397783	REAR PANEL	1
838	9120205	#8 X 1/2 PAN HEAD SHEET METAL SCREW [PACK OF 3]	1
839	9120370	7/32 I.D. X 1/2 O.D. X .032/.065 THICK FLAT WASHER [PACK OF 10]	1
840	9121390	11/32 I.D. X 11/16 O.D. X .051/.080 THICK SAE FLAT WASHER (5/16) [PACK OF 10]	1
841	9121370	5/16-18 X 3 1/4 HEX BOLT [PACK OF 2]	1
842	9121885	5/16-18 X 1 SOCKET HEAD CAP SCREW [PACK OF 2]	2
843	9121390	11/32 I.D. X 11/16 O.D. X .051/.080 THICK SAE FLAT WASHER (5/16) [PACK OF 10]	2
844	2397651	BRACKET, DECK HEIGHT	1
845	9121470	5/16-18 X 1 FLAT HEAD PHILLIPS MACHINE SCREW [PACK OF 5]	2
846	2391461	BUSHING - LIFT LEVER	2

AB, DB REAR PANEL ASSEMBLY

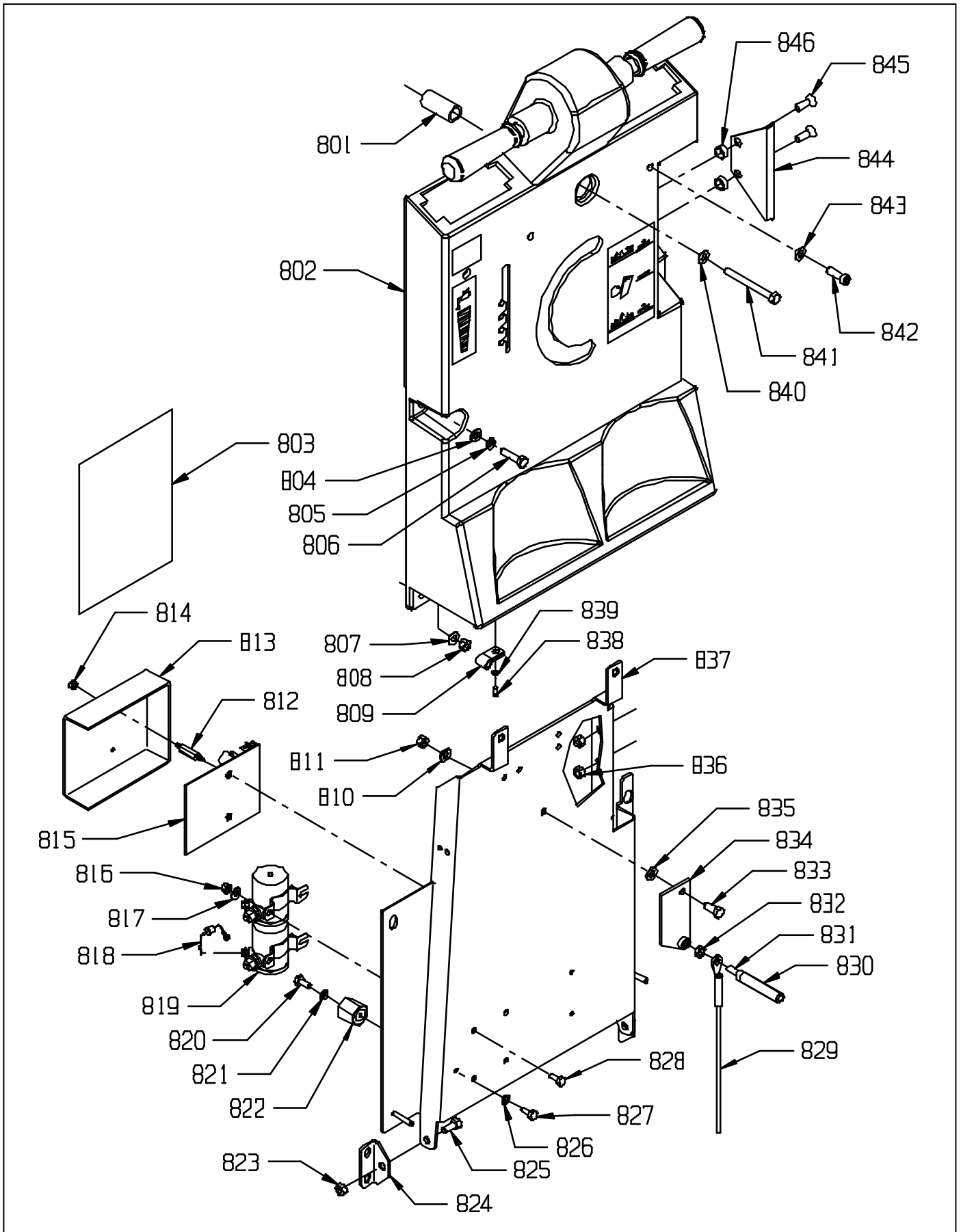

AB, DB HANDLE ASSEMBLY

ITEM	PART NO.	DESCRIPTION	QTY.
901	4890781	PUSH BUTTON SWITCH BOOT	1
902	2690691	MASTER SWITCH WITH RED CAP	1
903	0693141	RUBBER SWITCH BOOT	2
904	0691851	1/2 INTERNAL STAR LOCK WASHER	2
905	9120205	#8 X 1/2 PAN HEAD PHILLIPS SHEET METAL SCREW [PACK OF 3]	8
906	1392371	BATTERY METER W/ LOW VOLTAGE RELAY & HARDWARE	1
907	2391361	CIRCUIT BREAKER 30 AMP WITH SCREW TERMINALS	1
908	2490891	CIRCUIT BREAKER 15 AMP (USED ON DB ONLY)	1
909	2393791	CIRCUIT BREAKER 40 AMP WITH SCREW TERMINALS	1
910	4491101	TOGGLE SWITCH	1
911	2397321	DASH PLATE – LEFT	1
912	2792041	SWITCH, TOGGLE VAC	1
913	2397341	DASH PLATE - RIGHT WITH MASTER SWITCH CUT OUT	1
914	3392901	HANDLE GRIP	2
915	9121980	7/16 I.D. X 1 O.D. X .075/.080 THICK SAE FLAT WASHER (3/8) [PACK OF 2]	2
916	2397091	HANDLE, AB AND AE	1
	2397171	HANDLE, DB	1
	2393871	HANDLE, DB AND E-STOP	1
917	2398191	LABEL KIT	1
918	4990321	FUSE HOLDER WITH NUT AND WASHER	1
919	6496451	FAST-ACTING FUSE 2 AMP	1
920	9120930	9/32 I.D. X 5/8 O.D. X .051/.080 THICK FLAT WASHER (1/4) [PACK OF 10]	4
921	9120880	1/4 SPLIT LOCK WASHER [PACK OF 10]	4
922	9121210	1/4-20 X 5/8 HEX BOLT [PACK OF 10]	4
923	2398053	OBC MOUNT	1
924	4890851	CABLE CLAMP	1
925	2695841	BRACKET, MTG, DP CHARGER	2
926	9120810	#10 X 1/2 PAN HEAD PHILLIPS SHEET METAL SCREW [PACK OF 10]	6
927	9121210	1/4-20 X 5/8 HEX BOLT [PACK OF 10]	2
928	9120970	1/4 STAR LOCK WASHER [PACK OF 10]	3
929	3291111	CORD CLAMP	1
930	2695851	ONBOARD CHARGER 24 VOLT 25 AMP DP - INCLUDES:	1
	2695861	CORD WRAP	1
931	2398171	5/16 RING 22-18 AWG NYLON INSULATION	1
932	2398181	1/4 RING 16-14 AWG NYLON INSULATION	1
933	9121170	1/4-20 X 1/2 HEX BOLT [PACK OF 10]	2
934	9120880	1/4 SPLIT LOCK WASHER [PACK OF 10]	1
936	1390773	DRAIN HOSE BRACKET	2
937	9120880	1/4 SPLIT LOCK WASHER [PACK OF 10]	4
938	9121210	1/4-20 X 5/8 HEX BOLT [PACK OF 10]	4
939	1392191	120 VOLT ONBOARD CHARGER 24 VOLT 12 AMP	1
940	9120880	1/4 SPLIT LOCK WASHER [PACK OF 10]	1
941	9121210	1/4-20 X 5/8 HEX BOLT [PACK OF 10]	1
942	3291111	CORD CLAMP	1
943	9120320	#10 SPLIT LOCK WASHER [PACK OF 10]	4
944	9120510	#10-24 X 1/2 TRUSS HEAD PHILLIPS MACHINE SCREW [PACK OF 10]	4
945	6495701	120 VOLT ONBOARD CHARGER CORD	1
	6495711	240 VOLT ONBOARD CHARGER CORD WITH SHUKO PLUG	1
	0396271	240 VOLT ONBOARD CHARGER CORD WITH TYPE I PLUG (CHINA)	1
946	2398259	KEY SWITCH / HOUR METER KIT (OPTIONAL)	1
946A	7692511	KEY SWITCH & KEY	1
946A1	7692521	REPLACEMENT KEY	1
	6495571	WIRE ASSEMBLY - KEY SWITCH ADAPTOR (NOT SHOWN)	1
946B	2397351	DASH PLATE - RIGHT, OPTIONAL KEY SWITCH AND HOUR METER	1
946C	2397361	HOUR METER	1
	2398121	HOUR METER LEADS 35" (NOT SHOWN)	1
947	3393591	STRAINER LOCATION LABEL	1
948	2393651	BATTERY METER BEZEL RING	1
949	2393661	BATTERY METER U-BRACKET	1
950	3393521	E-STOP (OPTIONAL)	1
951	7691301	E-STOP CONTACT BLOCK	1
952	3394561	MAX INCLINE LABEL (DB MODELS ONLY)	1
953	3394721	FUSE LABEL	1
954	2398291	MAX CLIMBING INCLINE LABEL (DB MODELS ONLY)	1

AB, DB HANDLE ASSEMBLY

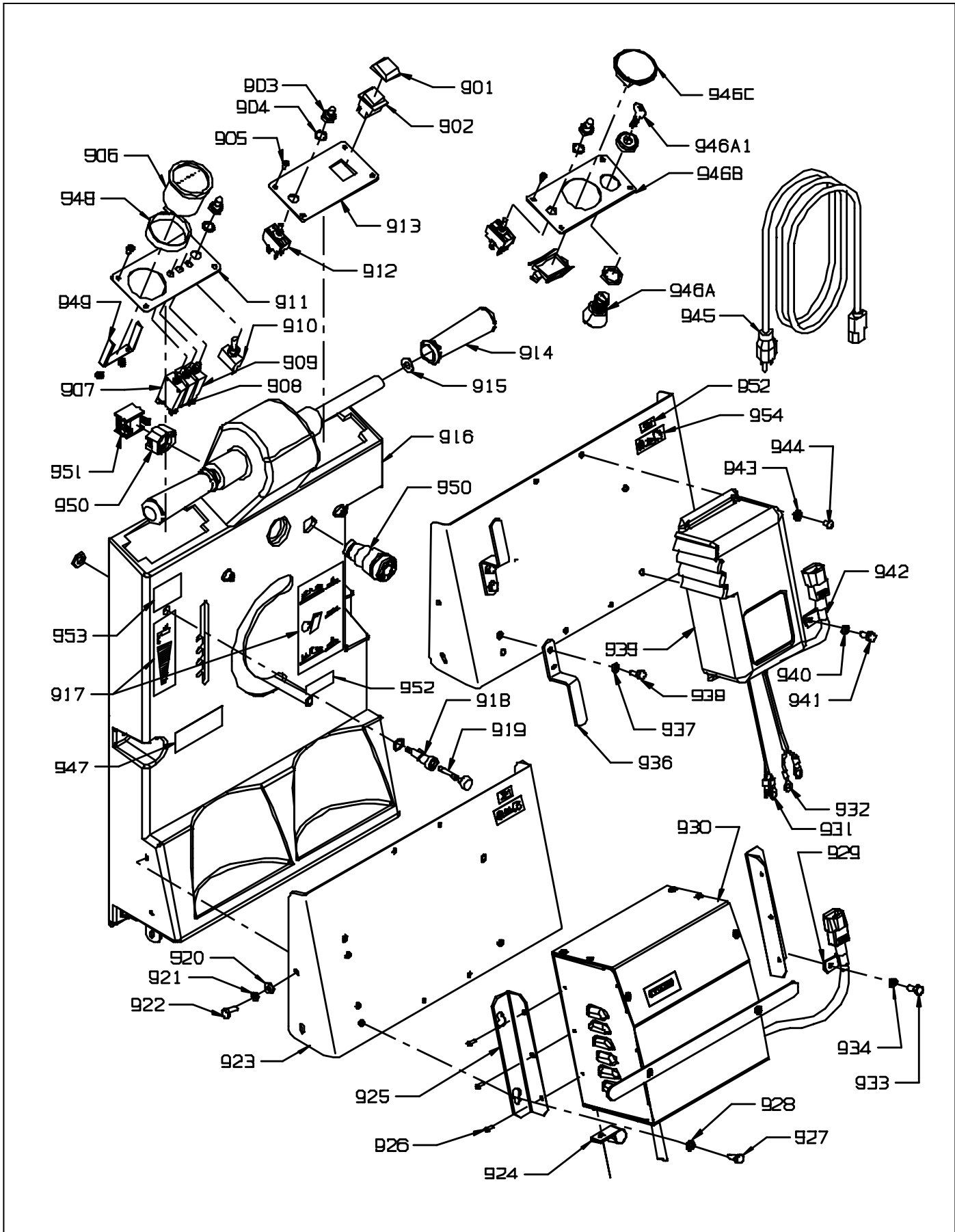

DB TWIST GRIP ASSEMBLY

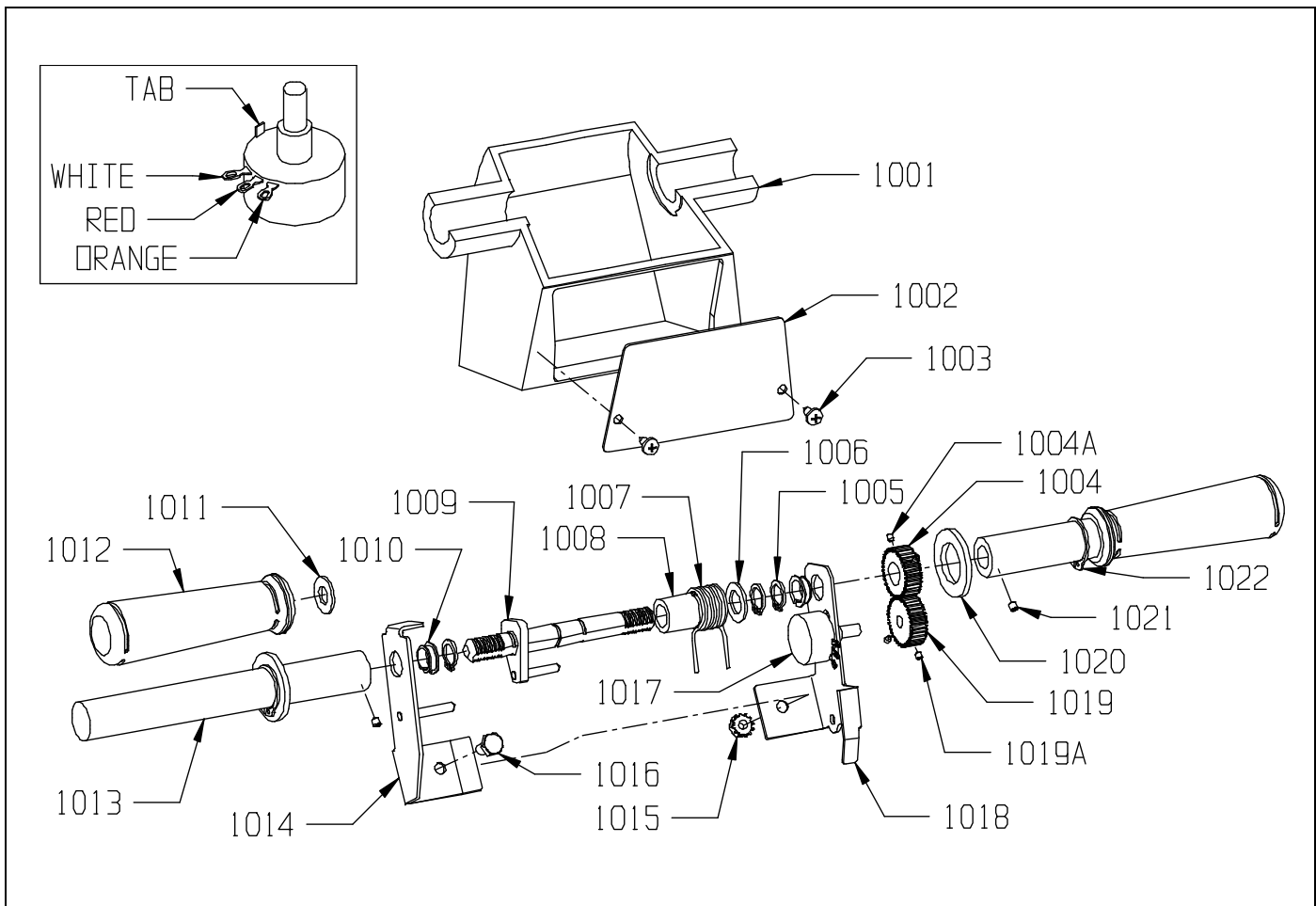

ITEM	PART NO.	DESCRIPTION	QTY.
1001	2397171	HANDLE, WHEEL DRIVE	1
1002	2397453	COVER - WHEEL DRIVE HANDLE	1
1003	9120205	#8 X 1/2 PAN HEAD PHILLIPS SHEET METAL SCREW [PACK OF 3]	2
1004	2691931	DRIVE GEAR, HANDLE BAR - INCLUDES:	1
1004A	9120170	#8-32 X 3/16 SET SCREW - KNURL POINT STEEL [PACK OF 5]	2
1005	9122496	RETAINING RING	3
1006	3393841	WASHER, AN 1/2 X .053-.073	1
1007	6496091	SPRING TORSION .81 I.D. X .067 WIRE	1
1008	6496081	BEARING PLAIN SLEEVE .5 X .75 X .75 LONG	1
1009	2398061	HANDLE BAR 2016	1
1010	7690691	NYLINER	2
1011	9121980	7/16 I.D. X 1 O.D. X .075/.080 THICK SAE FLAT WASHER (3/8) [PK 2]	2
1012	3392901	HANDLE GRIP	2
1013	2397261	HANDLE GRIP BASE	2
1014	2398071	TWIST GRIP BRACKET, LEFT SIDE	1
1015	9120910	1/4-20 HEX NUT WITH STAR LOCK WASHER [PACK OF 10]	1
1016	9121170	1/4-20 X 1/2 HEX BOLT [PACK OF 10]	1
1017	2694131	POTENTIOMETER	1
1018	2397231	TWIST GRIP BRACKET, RIGHT SIDE	1
1019	2691941	DRIVEN GEAR, POTENTIOMETER - INCLUDES:	1
1019A	9120170	#8-32 X 3/16 SET SCREW - KNURL POINT STEEL [PACK OF 5]	2
1020	9123210	.891 I.D. X 1.5 O.D. X .125 THICK FLAT WASHER [PACK OF 1]	2
1021	9120840	1/4-20 X 3/16 SET SCREW - KNURL POINT [PACK OF 2]	2
1022	2397221	RETAINING RING, 7/8" SHAFT	2

STRAIGHT SQUEEGEE ASSEMBLY

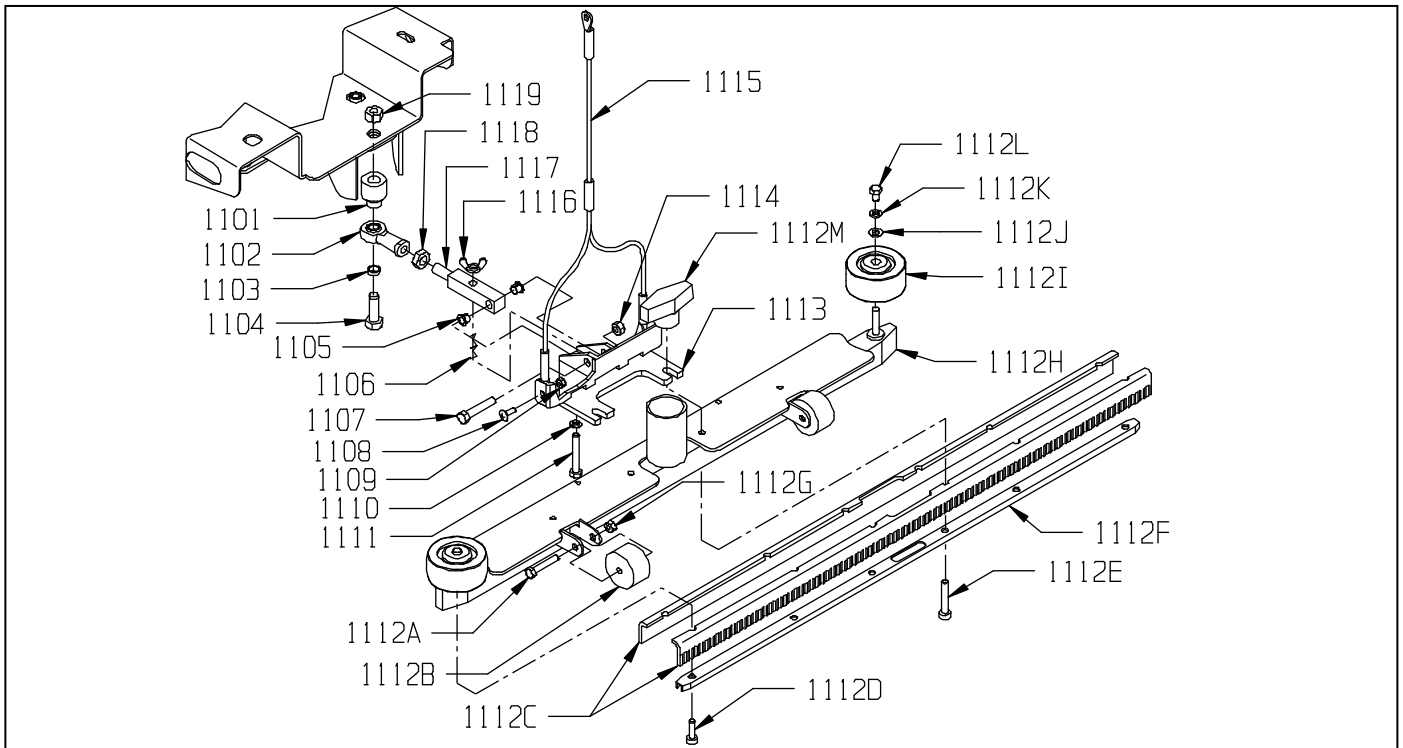

<u>ITEM</u>	<u>PART NO.</u>	<u>DESCRIPTION</u>	<u>QTY.</u>
1101	2398041	SPACER 1/2 I.D. X 1.188	1
1102	2391941	BALL JOINT	1
1103	2391461	BUSHING, LIFT LEVER	1
1104	9122657	1/2-13 X 3 LOCKING HEX BOLT [PACK OF 1]	1
1105	1391171	3/8 FLANGE NYLINER	2
1106	3695581	HEIGHT ADJUSTING SPRING	1
1107	9122340	3/8-16 X 2 HEX BOLT [PACK OF 2]	1
1108	9121010	1/4-20 X 3/4 TRUSS HEAD PHILLIPS MACHINE SCREW [PACK OF 5]	2
1109	9120900	1/4-20 HEX NUT WITH NY-LOK INSERT [PACK OF 10]	2
1110	9121520	5/16 SPLIT LOCK WASHER [PACK OF 10]	1
1111	9121840	5/16-18 X 2 1/4 FULL THREADED HEX BOLT [PACK OF 1]	1
1112	2692539	STRAIGHT SQUEEGEE ASSEMBLY - INCLUDES:	1
1112A	9121760	5/16-18 X 1 3/4 HEX BOLT [PACK OF 2]	2
1112B	3096741	WHEEL, BUMPER - SMALL GREY	2
1112C	2793009	32" REPLACEMENT SQUEEGEE BLADES	2
1112D	9121880	5/16-18 X 3/4 SOCKET HEAD CAP SCREW [PACK OF 2]	2
1112E	9121920	5/16-18 X 1 1/2 SOCKET HEAD CAP SCREW [PACK OF 2]	2
1112F	2692533	INNER CHANNEL	1
1112G	9121450	5/16-18 HEX NUT WITH NY-LOK INSERT [PACK OF 5]	2
1112H	2692523	HOUSING - NARROW MOUNT SQUEEGEE	1
1112I	2790281	3" BUMPER WHEEL	2
1112J	9121390	11/32 I.D.X11/16 O.D.X.051/.080 THICK SAE FLAT WASHER (5/16) [PACK OF 10]	2
1112K	9121410	5/16 EXTERNAL STAR LOCK WASHER [PACK OF 10]	2
1112L	9121560	5/16-18 X 1/2 HEX BOLT [PACK OF 5]	2
1112M	3392971	T-KNOB - SQUEEGEE	2
1113	2397151	SQUEEGEE MOUNT BRACKET	1
1114	9122140	3/8-16 HEX NUT WITH NY-LOK INSERT [PACK OF 5]	1
1115	2495301	Y SQUEEGEE LIFT CABLE 25"/63.5 cm	1
1116	9121445	5/16-18 WING NUT WITH NY-LOK [PACK OF 2]	1
1117	2397161	SQUEEGEE PIVOT ROD	1
1118	9122670	1/2-20 HEX JAM NUT [PACK OF 5]	1
1119	9122507	1/2-13 HEX NUT WITH NY-LOK INSERT [PACK OF 1]	1

CURVED SQUEEGEE ASSEMBLY

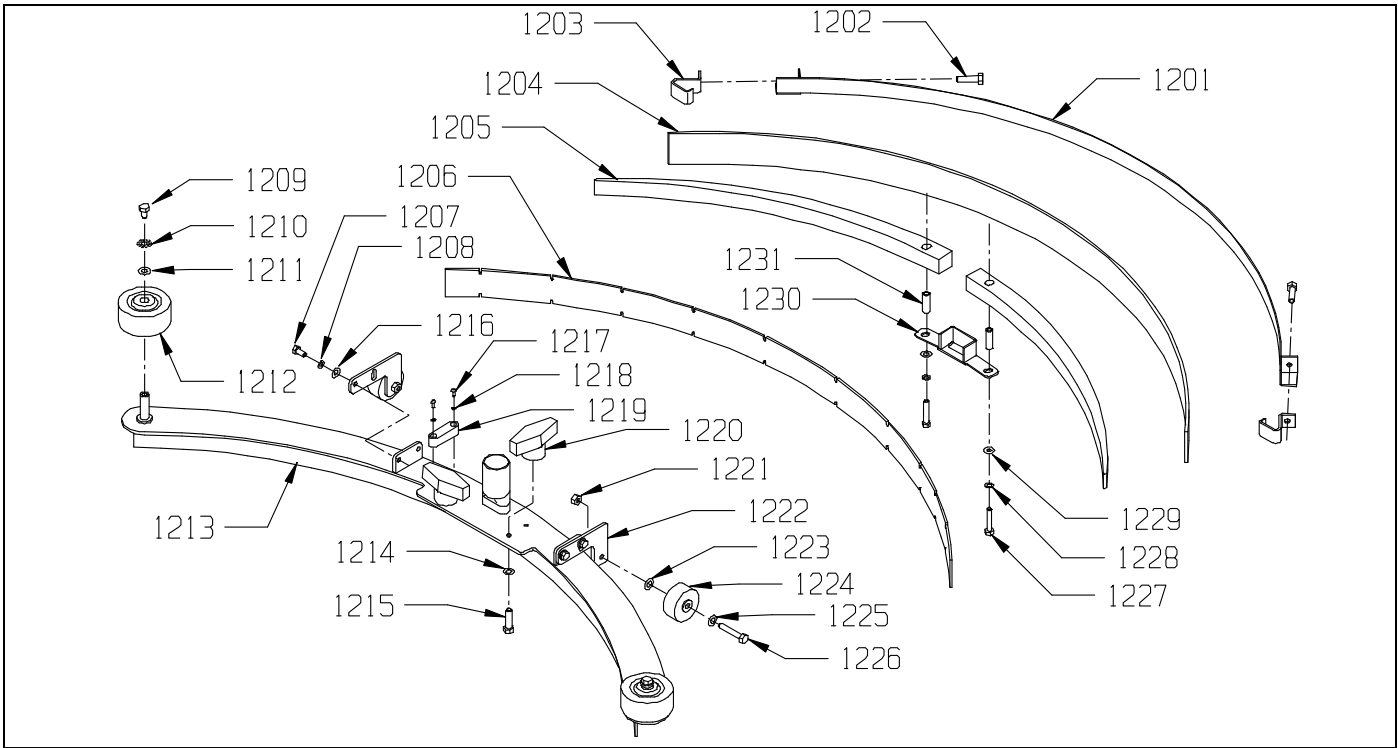

<u>ITEM</u>	<u>PART NO.</u>	<u>DESCRIPTION</u>	<u>QTY.</u>
	2492499	CURVED SQUEEGEE COMPLETE - INCLUDES:	1
1201	2492551	REAR SECURING STRAP	1
1202	9121720	5/16-18 X 1 1/4 FULL THREADED HEX HEAD BOLT [PACK OF 2]	2
1203	2492561	HOOKED END	2
1204	2695541	REAR BLADE	1
1205	2492511	CENTER WEDGE	2
1206	2492521	FRONT BLADE	1
1207	9121210	1/4-20 X 5/8 HEX BOLT [PACK OF 10]	4
1208	9120880	1/4 SPLIT LOCK WASHER [PACK OF 10]	4
1209	9121560	5/16-18 X 1/2 HEX BOLT [PACK OF 5]	2
1210	9121410	5/16 EXTERNAL STAR LOCK WASHER [PACK OF 10]	2
1211	9121390	11/32 ID X 11/16 OD X .051/.080 THICK SAE FLAT WASHER (5/16) [PK 10]	2
1212	2790281	BUMPER WHEEL	2
1213	2492503	MAIN HOUSING	1
1214	9121520	5/16 SPLIT LOCK WASHER [PACK OF 10]	2
1215	9121720	5/16-18 X 1 1/4 FULL THREADED HEX HEAD BOLT [PACK OF 2]	2
1216	9120930	9/32 I.D. X 5/8 O.D. X .051/.080 THICK SAE FLAT WASHER (1/4) [PACK OF 10]	4
1217	9120070	#6-32 X 3/8 ROUND HEAD PHILLIPS MACHINE SCREW [PACK OF 10]	2
1218	9120030	#6 SPLIT LOCK WASHER [PACK OF 10]	2
1219	2492581	SQUEEGEE LEVEL	1
1220	3392971	T-KNOB SQUEEGEE	2
1221	9121450	5/16-18 HEX NUT WITH NY-LOK INSERT [PACK OF 5]	2
1222	2492571	DOLLY WHEEL MOUNTING BRACKET	2
1223	9121390	11/32 I.D. X 11/16 O.D. X .051/.080 THICK SAE FLAT WASHER (5/16) [PK 10]	2
1224	3096741	ROLLER WHEEL	2
1225	9121390	11/32 I.D. X 11/16 O.D. X .051/.080 THICK SAE FLAT WASHER (5/16) [PK 10]	2
1226	9121760	5/16-18 X 1 3/4 HEX BOLT [PACK OF 2]	2
1227	9121280	1/4-20 X 1 1/2 HEX BOLT [PACK OF 5]	2
1228	9120880	1/4 SPLIT LOCK WASHER [PACK OF 10]	2
1229	9120930	9/32 I.D. X 5/8 O.D. X .051/.080 THICK SAE FLAT WASHER (1/4) [PACK OF 10]	2
1230	2492541	CENTER HOLD DOWN	1
1231	2492591	CENTER HOLD DOWN SPACER	2

AE WIRING DIAGRAM

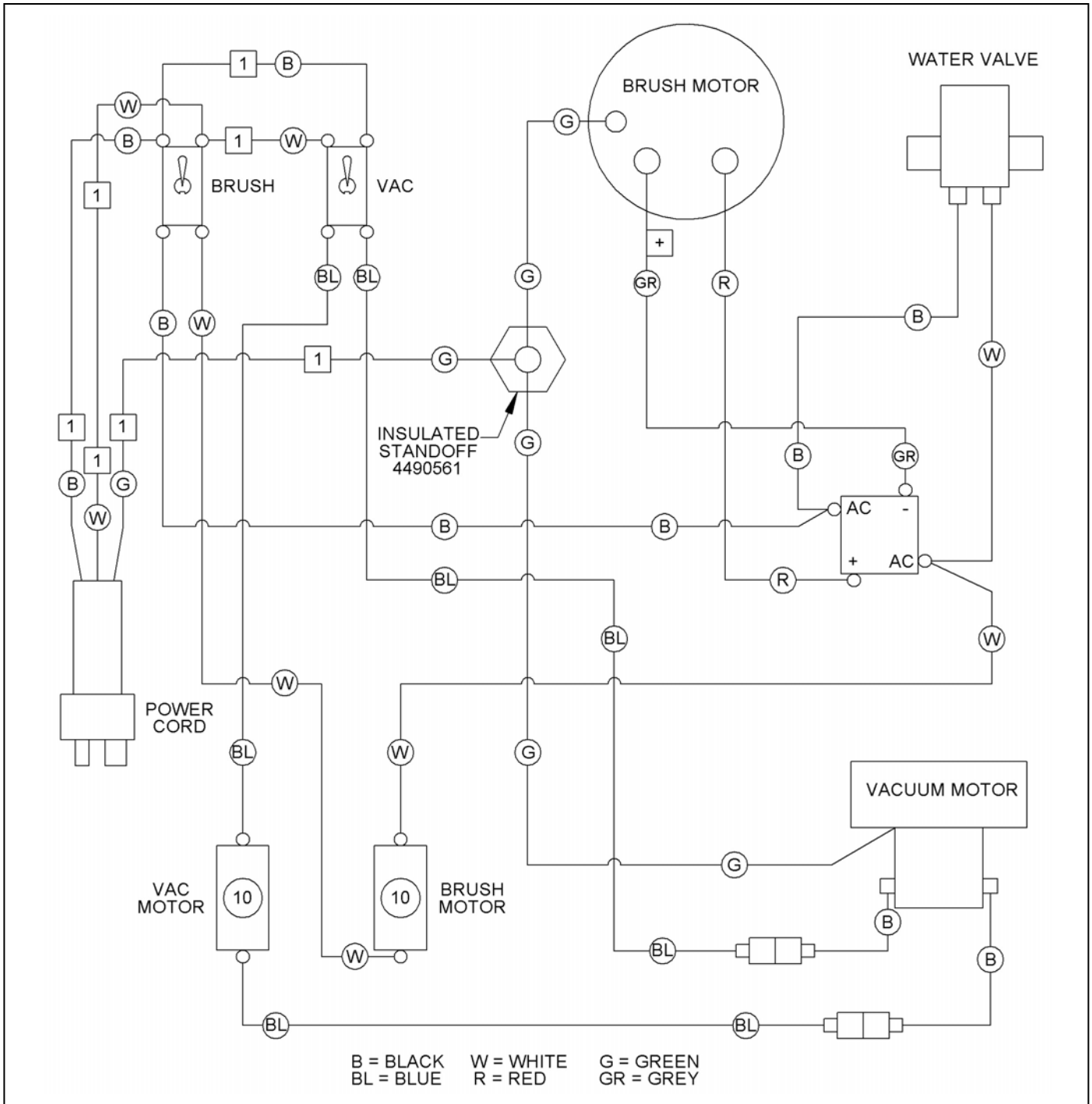

<u>ITEM</u>	<u>PART NO.</u>	<u>DESCRIPTION</u>	<u>QTY.</u>
1	2397701	WIRE HARNESS, ELECTRIC	1
	2397711	STUB CORD WIRE HARNESS	1
	2792041	TOGGLE SWITCH	2
	2393011	BRUSH MOTOR	1
	2397721	SOLUTION SOLENOID VALVE 120 VOLT	1
	4490561	INSULATED STANDOFF	1
	5492741	RECTIFIER	1
	2392201	CIRCUIT BREAKER	2
	2391071	VAC MOTOR	1
	5490161	FULLY INSULATED FEMALE SPADE TERMINAL 14-16 AWG	2

DB WIRING DIAGRAM 4 X 6VOLT 235AH BATTERIES

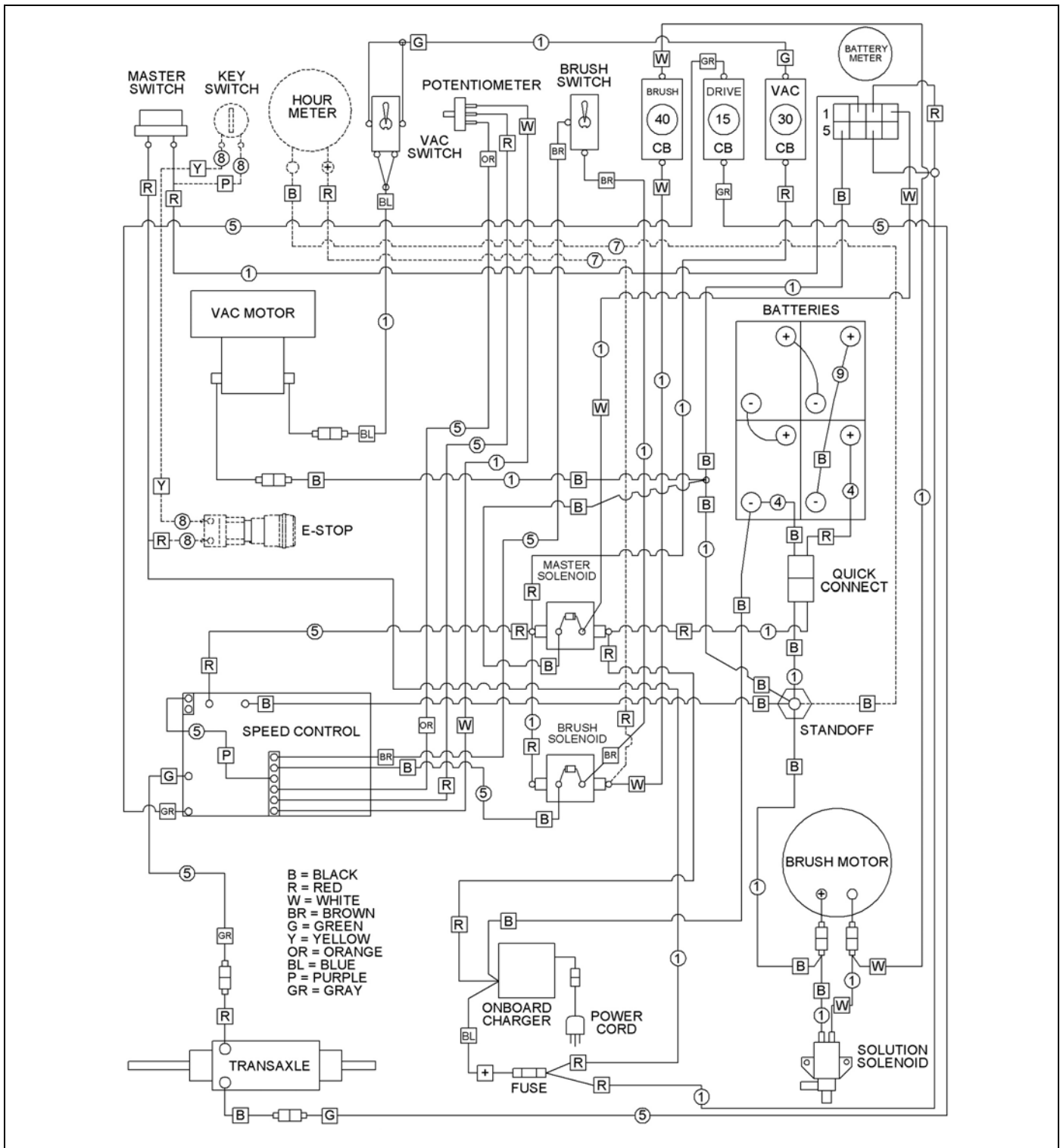

ITEM	PART NO.	DESCRIPTION	QTY.
1	2398201	MAIN WIRE HARNESS (OBC)	1
4	2396141	WIRE ASSEMBLY, TO POSITIVE/NEGATIVE BATTERY	1
5	2398091	DB WIRE HARNESS (OBC)	1
9	2391981	BATTERY JUMPER 3/8 RING	3
8	2393861	WIRE HARNESS, KEYSWITCH & E-STOP	1
	6495571	WIRE ASSEMBLY WITH KEY SWITCH ADAPTOR	1
7	2398121	HOUR METER LEADS 35"	1

DB WIRING DIAGRAM 2 X 12VOLT 130AH BATTERIES

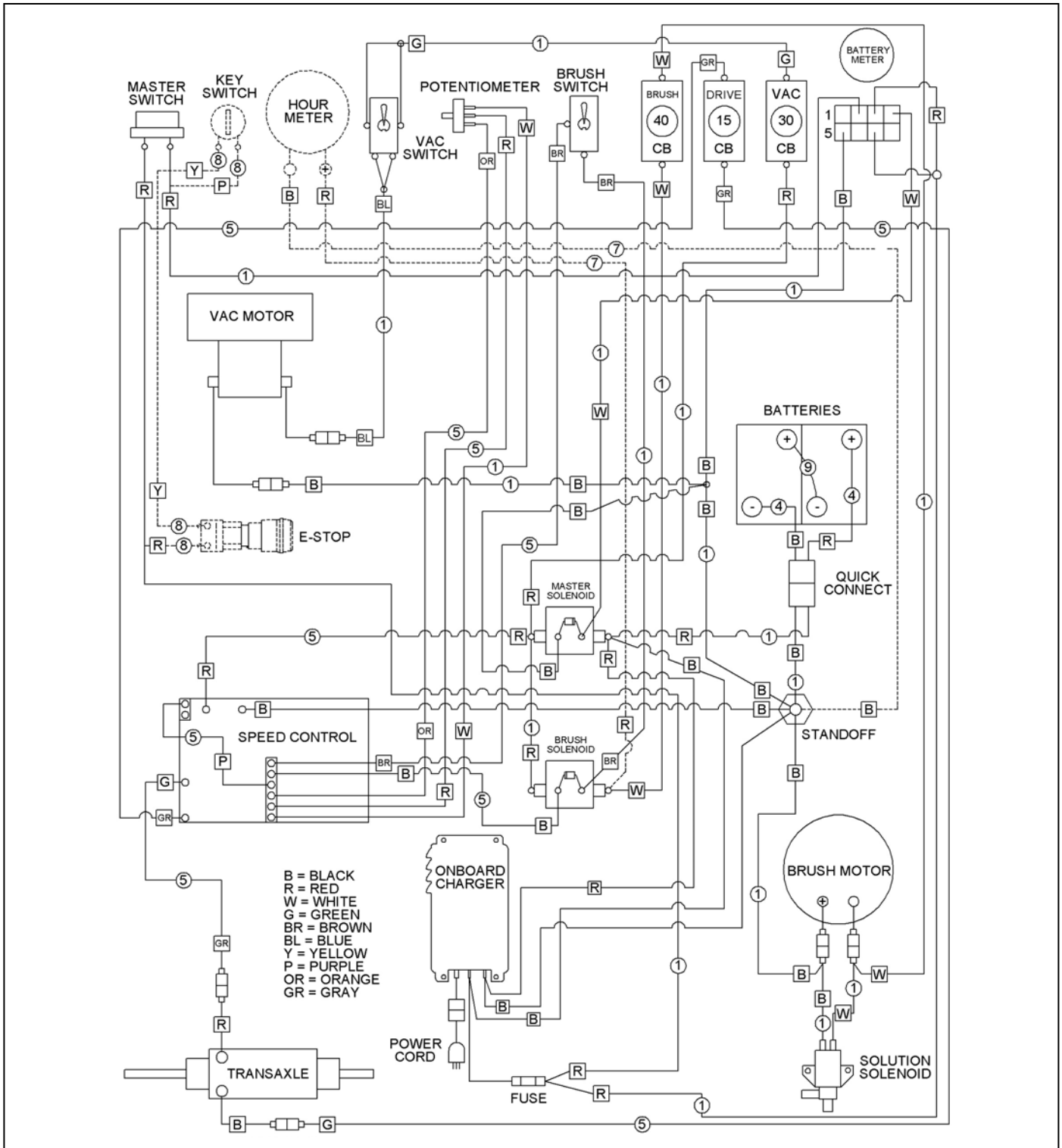

ITEM	PART NO.	DESCRIPTION	QTY.
1	2398201	MAIN WIRE HARNESS (OBC)	1
4	2396141	WIRE ASSEMBLY, TO POSITIVE/NEGATIVE BATTERY	1
5	2398091	DB WIRE HARNESS (OBC)	1
9	2391981	BATTERY JUMPER 3/8 RING	1
8	2393861	WIRE HARNESS, KEYSWITCH & E-STOP	1
	6495571	WIRE ASSEMBLY WITH KEY SWITCH ADAPTOR	1
7	2398121	HOUR METER LEADS 35"	1

AB WIRING DIAGRAM 4 X 6VOLT 235AH BATTERIES

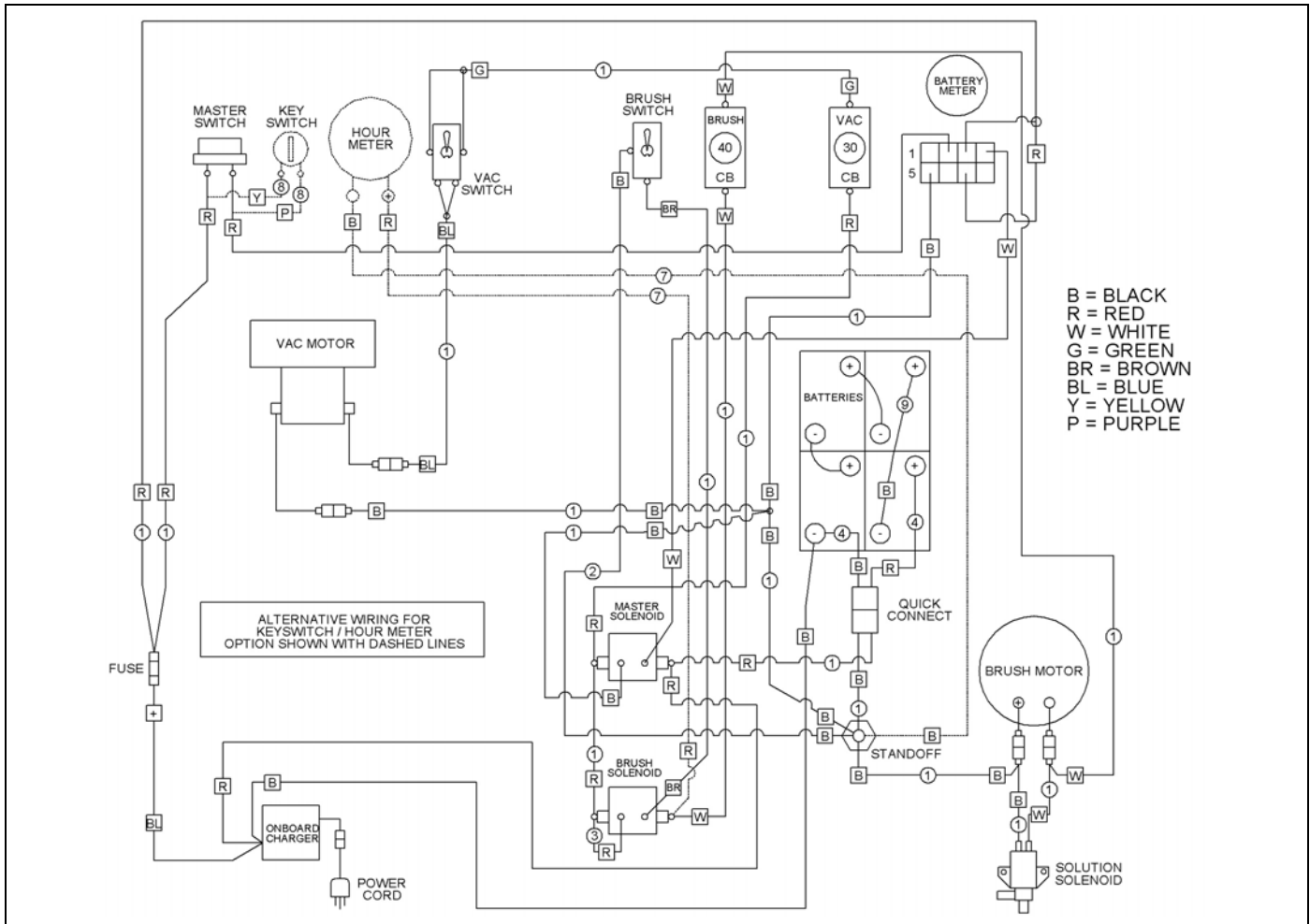

<u>ITEM</u>	<u>PART NO.</u>	<u>DESCRIPTION</u>	<u>QTY.</u>
1	2398201	MAIN WIRE HARNESS (OBC)	1
2	2398111	WIRE 18 AWG, BLACK 30" 1/4 RING, 1/4 FEMALE SPADE	1
3	2398101	WIRE 18 AWG RED, 4.5", 5/16 RING , #10 SNAP RING	1
4	2396141	WIRE ASSEMBLY, TO POSITIVE/NEGATIVE BATTERY	1
9	2391981	BATTERY JUMPER 3/8 RING	3
	2391351	CONTACTOR, 24 VOLT	1
	2393791	CIRCUIT BREAKER, 40 AMP	1
	1392371	BATTERY METER WITH LOW VOLTAGE RELAY	1
	2392091	CHARGER PLUG ONLY, RED 24 VOLT	1
	2393001	GEAR MOTOR, IMPERIAL, 3/4 HP 24V DC	1
	2395571	MOTOR, VAC 24 VOLT 3 STAGE	1
	2397991	WATER SOLENOID 24 VOLT	1
	2391361	CIRCUIT BREAKER, 30 AMP, SCREW TERMINALS	1
	2398259	KEY SWITCH / HOUR METER KIT (OPTIONAL)	1
	2695851	ONBOARD CHARGER 24 VOLT 25 AMP DP	1
	2690691	MASTER SWITCH	1
	2792041	TOGGLE SWITCH, VAC	1
	4490561	INSULATED STANDOFF	1
	4491101	TOGGLE SWITCH, MOTOR	1
	4990321	FUSE HOLDER WITH NUT AND WASHER	1
	6495701	120 VOLT ONBOARD CHARGER CORD	1
	6495711	240 VOLT ONBOARD CHARGER CORD WITH SHUKO PLUG	1
	0396271	240 VOLT ONBOARD CHARGER CORD WITH TYPE I PLUG (CHINA)	1
	6496451	FAST-ACTING FUSE 2 AMP	1

AB WIRING DIAGRAM 2 X 12VOLT 130AH BATTERIES

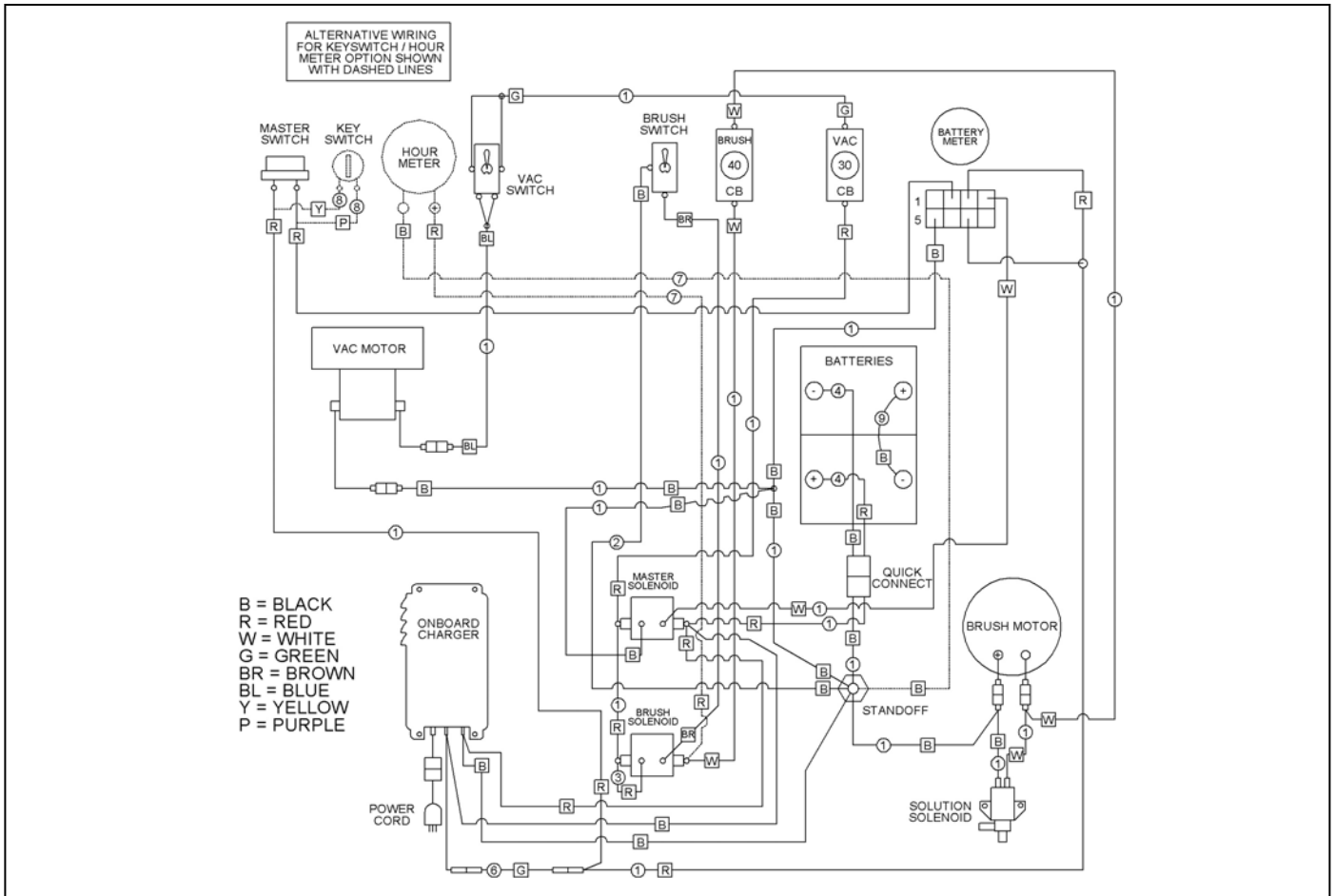

ITEM	PART NO.	DESCRIPTION	QTY.
1	2398201	MAIN WIRE HARNESS (OBC)	1
2	2398111	WIRE 18 AWG, BLACK 30" 1/4 RING, 1/4 FEMALE SPADE	1
3	2398101	WIRE 18 AWG RED, 4.5", 5/16 RING, #10 SNAP RING	1
4	2396141	WIRE ASSEMBLY, TO POSITIVE/NEGATIVE BATTERY	1
6	2393741	WIRE 18 AWG GREEN, 17", 1/4 FEMALE QD, 1/4 MALE QD	1
9	2391981	BATTERY JUMPER 3/8 RING	1
	1392191	120 VOLT ONBOARD CHARGER 24 VOLT 12 AMP	1
	2391351	CONTACTOR, 24 VOLT	1
	2393791	CIRCUIT BREAKER, 40 AMP	1
	1392371	BATTERY METER WITH LOW VOLTAGE RELAY	1
	2392091	CHARGER PLUG ONLY, RED 24 VOLT	1
	2393001	GEAR MOTOR, IMPERIAL, 3/4 HP 24V DC	1
	2395571	MOTOR, VAC 24 VOLT 3 STAGE	1
	2397991	WATER SOLENOID 24 VOLT	1
	2391361	CIRCUIT BREAKER, 30 AMP, SCREW TERMINALS	1
	2398171	5/16 RING 22-18 AWG NYLON INSULATION	1
	2398181	1/4 RING 16-14 AWG NYLON INSULATION	1
	2398259	KEY SWITCH / HOUR METER KIT (OPTIONAL)	1
	2690691	MASTER SWITCH WITH RED CAP	1
	2792041	TOGGLE SWITCH, VAC	1
	4490561	INSULATED STANDOFF	1
	4491101	TOGGLE SWITCH, MOTOR	1
	4990321	FUSE HOLDER WITH NUT AND WASHER	1
	6495701	120 VOLT ONBOARD CHARGER CORD	1
	6495711	240 VOLT ONBOARD CHARGER CORD WITH SHUKO PLUG	1
	6496451	FAST-ACTING FUSE 2 AMP	1

BRUSH GEAR MOTOR

ITEM	PART NO.	DESCRIPTION	QTY.
	2393001	COMPLETE MOTOR ASSEMBLY	1
1301	3391221	NEGATIVE LEAD	1
1302	3391201	1/4-20 X 7 3/4 THRU BOLT	2
1303	9120600	#10-24 X 1/2 PAN HEAD THREAD CUTTING SCREW [PACK OF 10]	2
1304	2393251	ARMATURE ASSEMBLY - INCLUDES:	1
1304A	5092041	TOP END BEARING	1
1304B	3391191	ARMATURE VENT FAN	1
1304C	3391131	BOTTOM END BEARING	1
1305	3391041	STATOR FRAME ASSEMBLY WITH MAGNETS	1
1306	3391181	GEAR BOX ASSEMBLY - INCLUDES	1
1306A	3391101	GEAR BOX - HOUSING ONLY	1
1306B	3391171	SNAP RING	1
1306C	3391161	OIL SEAL. SMALL	1
1306D	3391151	END CAP	1
1306E	3391141	"O" RING	1
1306F	3391131	BOTTOM BEARING. LARGE	1
1306G	3391121	GEAR SHAFT - INCLUDES:	1
1306G1	2792681	1/4 X 1/4 X 1 MOTOR KEY	1
1306H	3391111	TOP BEARING. SMALL	1
1307	3391091	OIL SEAL. LARGE	1
1308	2797591	HELICAL WASHER 1 13/32 X 1 7/8 - 2 WAVE SPRING WASHER	1
1309	-----	#10-32 X 1/2 PAN HEAD SLOTTED SCREW. BRASS	4
1310	-----	TOP END BRACKET ASSEMBLY - INCLUDES:	1
1310A	-----	TOP END BRACKET ONLY	1
1310B	3391021	BRUSH BOARD ASSEMBLY - INCLUDES:	1
1310B1	2797571	CARBON BRUSH SPRING	4
1310B2	3391081	CARBON BRUSH	4
1311	-----	STRAIN RELIEF	2
1312	3391211	POSITIVE LEAD	1
1313	3391131	LARGE BEARING	1
2016 ELECTRIC 120V LISTED BELOW [2307100]			
	2393011	COMPLETE MOTOR ASSEMBLY 120 VOLT	1
1301	2393271	NEGATIVE LEAD	1
1302	3391201	1/4-20 X 7 3/4 THRU BOLT	2
1303	9120600	#10-24 X 1/2 PAN HEAD THREAD CUTTING SCREW [PACK OF 10]	2
1304	2393161	ARMATURE ASSEMBLY - INCLUDES:	1
1304A	5092041	TOP END BEARING	1
1304B	3391191	ARMATURE VENT FAN	1
1304C	3391131	BOTTOM END BEARING	1
1305	2393151	STATOR FRAME ASSEMBLY WITH MAGNETS	1
1306	3391181	GEAR BOX ASSEMBLY - INCLUDES:	1
1306A	3391101	GEAR BOX - HOUSING ONLY	1
1306B	3391171	SNAP RING	1
1306C	3391161	OIL SEAL. SMALL	1
1306D	3391151	END CAP	1
1306E	3391141	"O" RING	1
1306F	3391131	BOTTOM BEARING. LARGE	1
1306G	3391121	GEAR SHAFT - INCLUDES:	1
1306G1	2792681	1/4 X 1/4 X 1 MOTOR KEY	1
1306H	3391111	TOP BEARING. SMALL	1
1307	3391091	OIL SEAL. LARGE	1
1308	2797591	HELICAL WASHER 1 13/32 X 1 7/8 - 2 WAVE SPRING WASHER	1
1309	-----	#10-32 X 1/2 PAN HEAD SLOTTED SCREW. BRASS	4
1310	2393181	TOP END BRACKET ASSEMBLY - INCLUDES:	1
1310A	-----	TOP END BRACKET ONLY	1
1310B	2393171	BRUSH BOARD ASSEMBLY - INCLUDES:	1
1310B1	2797571	CARBON BRUSH SPRING	4
1310B2	2393241	CARBON BRUSH	4
1311	2393201	STRAIN RELIEF	2
1312	2393261	POSITIVE LEAD	1
1313	3391131	LARGE BEARING	1

BRUSH GEAR MOTOR

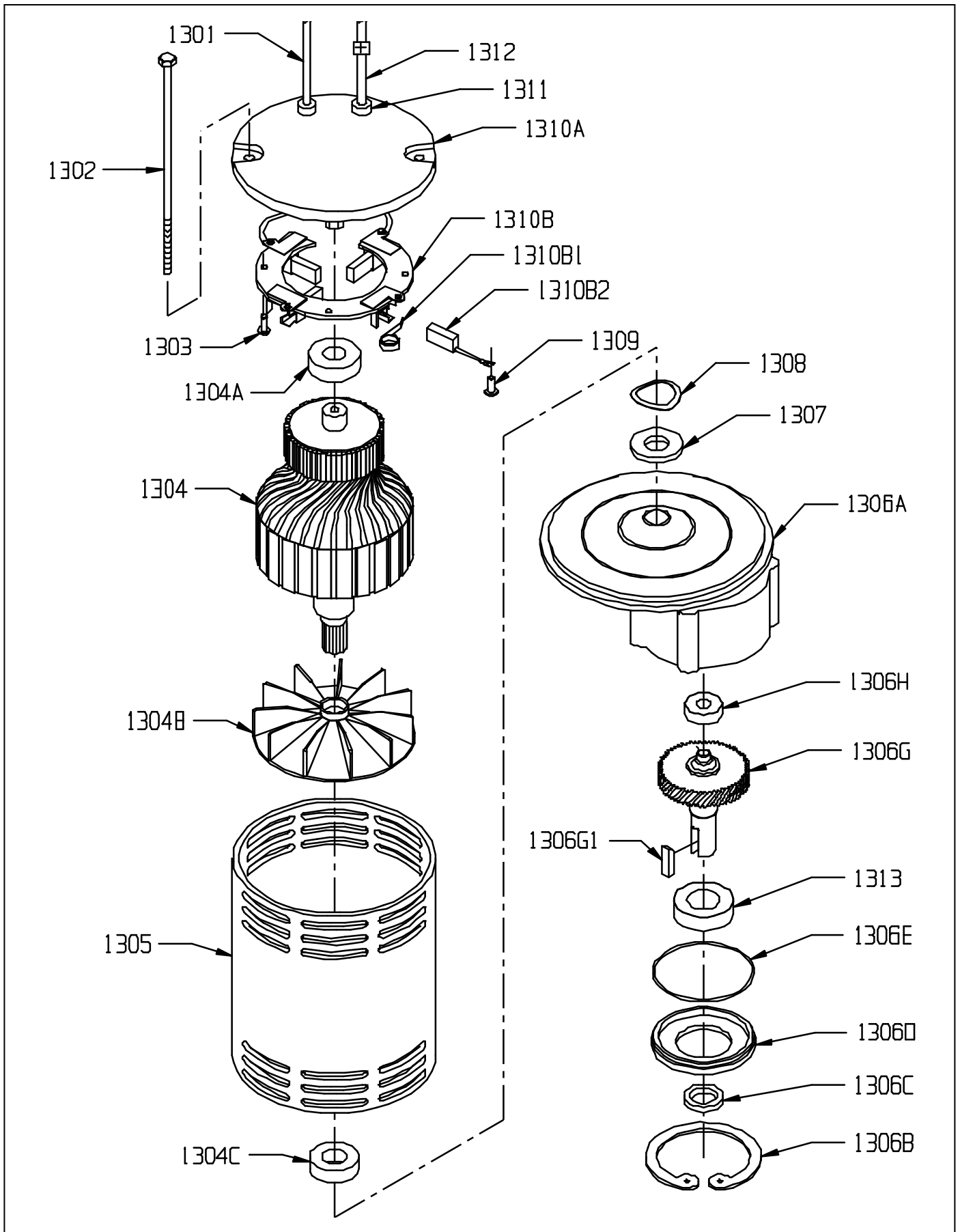

ACCESSORIES

CLUTCH PLATES



- 2893001 Aluminum Clutch Plate, 4" Diameter, 3 Holes
- 2890981 Plastic Clutch Plate, 4" Diameter 3 Holes
- 2890991 Aluminum Clutch Plate, 5" Diameter, 6 Holes
- 2890101 Plastic Clutch Plate, 5" Diameter, 6 Holes
- 2890971 Plastic Clutch Plate, 5" Diameter, 6 Holes Brown Tru Fit
- 2890101 Plastic Clutch Plate 5" Diameter, 6 Holes White Spin Off

PAD CUP

- 5990731 Cream Pad Cup

20" PAD DRIVERS AND BRUSHES



- 2892211 20" Poly Back Tufted Pad Driver
- 2892601 20" Structural Foam Pad Driver
- 2892031 20" Wood Back Bassine Scrub Brush - *general scrub*
- 2892201 20" Poly Back Nylon Fill Scrub Brush - *light to medium scrub*
- 2892651 20" Poly Back Fill Scrub Brush with glide - *carpet shampooing*
- 2892701 20" Poly Brush, Shower Feed - *Standard Carpet Scrub*
- 2892711 20" Poly Back Nylon Grit Fill Scrub Brush - *Heavy Concrete Scrub*
- 2892901 20" Poly Black Scrub Grit Brush - *Mild to Medium Scrub*

BURNISHING (175 TO 3000 RPM) FLOOR PADS

- 7992051 20" NSS Lite Blue Polish / Burnish Pad

SCRUBBING (150 TO 300 RPM) FLOOR PADS

- 7992041 20" NSS UHS Clean Buff Pad
- 7992031 20" NSS Blue Scrub Pad
- 7992021 20" NSS Green Scrub Pad

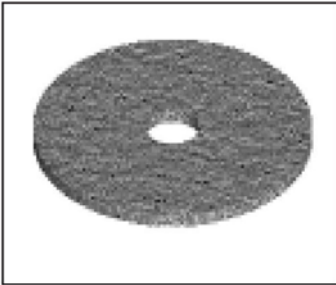

STRIPPING (150 TO 300 RPM) FLOOR PADS

- 7992001 20" NSS Black Strip Pad
- 7992011 20" NSS Brown Strip Pad
- 7990041 20" NSS Green Ecostrip Pad

TWISTER PADS

- 7992101 20" Twister Green Pad
- 7992121 20" Twister Yellow Pad
- 7992131 20" Twister White Pad
- 7992141 20" Twister Red Pad

TOOL KIT

2392129 Wrangler 20 Wet Pick Up Tool Kit -Includes:

- 2291211 5" Aluminum Connector
- 2391231 Vacuum Hose
- 2391241 Hose Strap
- 5790471 Lower Wand - 1-1/2"
- 5790481 Upper Wand - 1-1/2"
- 5797011 Tool - Squeegee With Wheels, 15"
- 9997550 Velcro Hook (1.583')
- 9997560 Velcro Loop (.833')



BATTERY & BATTERY ACCESSORIES

- 3390981 6V, 220 AH AGM Battery
- 6393651 12V, 130 AH Battery
- 3394161 Off Board Charger (40 amp) Adaptor
- 2698441 Dual Pro Charger Fan Refurbishment Kit
- 2698421 Dual Pro Charger Ring Terminal Refurbishment Kit



NSS® Enterprises, Inc.

3115 Frenchmens Road
Toledo, Ohio 43607
PHONE (419) 531-2121
FAX (419) 531-3761
mailus@nss.com
www.nss.com