

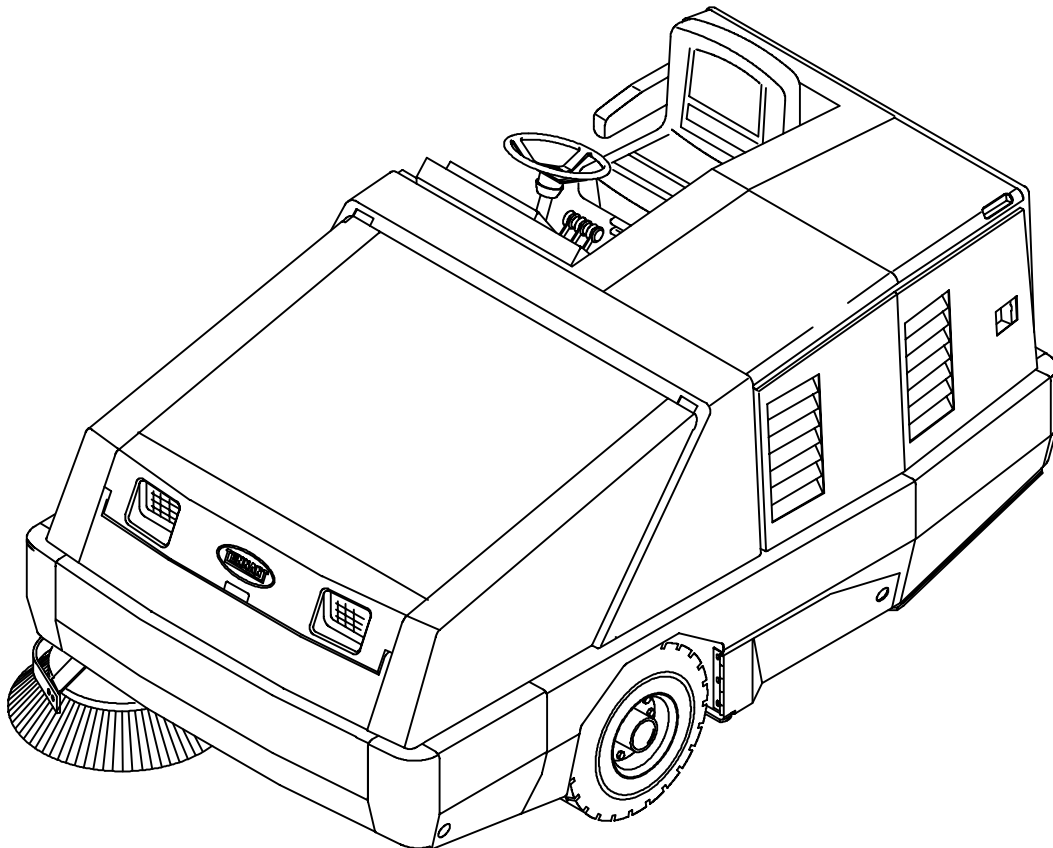

800/810

Gas/LP/Diesel
Service Manual



MM337
Rev. 04 (6-01)



This service manual is intended to be an aid for the disassembly and reassembly of your TENNANT Model 800/810.

The set is organized into eight major groups: General Information, Chassis, Sweeping, Electrical, Hydraulics, Engine-G/LPG, Engine-D, Perkins 200 Series, and Engine-D, Perkins 700 Series.

General Information: Machine transport, machine jacking, machine storage, machine specifications, and machine maintenance chart.

Chassis: Tire/wheel replacement, brake adjustment and replacement, chassis lubrication, steering adjustment and replacement, and cover/door adjustment.

Sweeping: Hopper repair/replacement, brush repair/replacement, skirt/seal repair/replacement, and sweeping troubleshooting

Electrical: Battery maintenance and replacement, instrument panel replacement, and electrical troubleshooting.

Hydraulics: Valve replacement/repair, motor replacement/repair, cylinder replacement/repair, pump replacement/repair, filter replacement, and hydraulics troubleshooting.

Engine - G/LPG: Air filter replacement, oil changing, cooling system maintenance/repair, fuel system maintenance/repair, governor adjustment/repair, engine repair, engine troubleshooting, and engine repairs.

Engine - D, Perkins 200 Series: Air filter replacement, oil changing, cooling system maintenance/repair, fuel system maintenance/repair, governor adjustment/repair, engine repair, engine troubleshooting, and engine repairs.

Engine - D, Perkins 700 Series: Air filter replacement, oil changing, cooling system maintenance/repair, fuel system maintenance/repair, governor adjustment/repair, engine repair, engine troubleshooting, and engine repairs.

Manual Number - MM337

Revision: 04

Published: 6-01



CALIFORNIA PROPOSITION 65 WARNING:

Engine exhaust from this product contains chemicals known to the State of California to cause cancer, birth defects, or other reproductive harm.

CONTENTS

	Page
SAFETY PRECAUTIONS	1-3
PUSHING, TOWING, AND TRANSPORTING THE MACHINE	1-5
PUSHING OR TOWING THE MACHINE	1-5
TRANSPORTING THE MACHINE	1-6
MACHINE JACKING	1-8
STORING MACHINE	1-8
SPECIFICATIONS	1-9
GENERAL MACHINE DIMENSIONS/CAPACITIES	1-9
GENERAL MACHINE PERFORMANCE ..	1-9
POWER TYPE: GAS/LP	1-10
POWER TYPE: DIESEL	1-11
STEERING	1-12
ELECTRICAL SYSTEM	1-12
800/810 ELECTRICAL	1-12
HYDRAULIC SYSTEM	1-12
HYDRAULIC PUMPS: CHAR-LYNN	1-12
HYDRAULIC MOTORS: GAS/LP	1-13
HYDRAULIC MOTORS: DIESEL	1-13
BRAKING SYSTEM	1-13
TIRES	1-13
MAINTENANCE - GAS/LPG	1-14
MAINTENANCE CHART	1-14
MAINTENANCE - DIESEL	1-16
MAINTENANCE CHART	1-16
HARDWARE INFORMATION	1-18
STANDARD BOLT TORQUE CHART	1-18
METRIC BOLT TORQUE CHART	1-18
BOLT IDENTIFICATION	1-19
THREAD SEALANT AND LOCKING COMPOUNDS	1-19

SAFETY PRECAUTIONS

The following precautions are used throughout this manual as indicated in their description:



WARNING: To warn of hazards or unsafe practices which could result in severe personal injury or death.

FOR SAFETY: To identify actions which must be followed for safe operation of equipment.

The machine is suited to sweep disposable debris. Do not use the machine other than described in this Operator Manual. The machine is not designed for use on public roads.

The following information signals potentially dangerous conditions to the operator or equipment:

FOR SAFETY:

1. **Do not operate machine:**
 - unless trained and authorized.
 - unless operator manual is read and understood.
 - if it is not in proper operating condition.
 - in flammable or explosive areas unless designed for use in those areas.
 - in areas with possible falling objects unless equipped with overhead guard.
2. **Before starting machine:**
 - check for fuel, oil, and liquid leaks.
 - keep sparks and open flame away from refueling area.
 - make sure all safety devices are in place and operate properly.
 - check brakes and steering for proper operation.
3. **When starting machine:**
 - keep foot on brake and directional pedal in neutral.
4. **When using machine:**
 - use brakes to stop machine.
 - go slow on inclines and slippery surfaces.
 - use care when reversing machine.
 - move machine with care when hopper is raised.
 - make sure adequate clearance is available before raising hopper.
 - do not carry passengers on machine.
 - always follow safety and traffic rules.
 - report machine damage or faulty operation immediately.

5. **Before leaving or servicing machine:**
 - stop on level surface.
 - set parking brake.
 - turn off machine and remove key.
6. **When servicing machine:**
 - avoid moving parts. do not wear loose jackets, shirts, or sleeves.
 - block machine tires before jacking machine up.
 - jack machine up at designated locations only. Block machine up with jack stands.
 - use hoist or jack that will support the weight of the machine.
 - wear eye and ear protection when using pressurized air or water.
 - disconnect battery connections before working on machine.
 - avoid contact with battery acid.
 - avoid contact with hot engine coolant.
 - allow engine to cool.
 - keep flames and sparks away from fuel system service area. Keep area well ventilated.
 - use cardboard to locate leaking hydraulic fluid under pressure.
 - use tennant supplied or approved replacement parts.
7. **When loading/unloading machine onto/off truck or trailer:**
 - Turn off machine.
 - Use truck or trailer that will support the weight of the machine.
 - Use winch. Do not drive the machine onto/off the truck or trailer unless the load height is 380 mm (15 in) or less from the ground.
 - Set parking brake after machine is loaded.
 - Block machine tires.
 - Tie machine down t truck or trailer.



WARNING: Engine emits toxic gases. Severe respiratory damage or asphyxiation can result. Provide adequate ventilation. Consult with your regulatory authorities for exposure limits. Keep engine properly tuned.



WARNING: Raised hopper may fall. Engage hopper support bar.



WARNING: Lift arm pinch point. Stay clear of hopper lift arms.



WARNING: Moving belt and fan. Keep away.

GENERAL INFORMATION

The following safety labels are mounted on the machine in the locations indicated. If these or any label becomes damaged or illegible, install a new label in its place.

EMISSIONS LABEL - LOCATED ON THE FRONT PANEL OF THE OPERATOR COMPARTMENT.



NOISE LABEL - LOCATED ON THE FRONT PANEL OF THE OPERATOR COMPARTMENT.

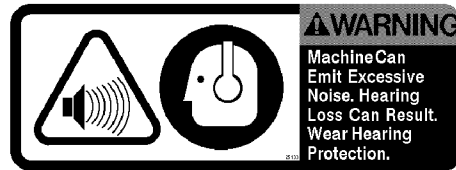

FOR SAFETY LABEL - LOCATED ON THE FRONT PANEL OF THE OPERATOR COMPARTMENT.

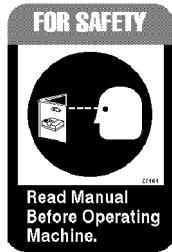

ENGINE FAN AND BELT LABEL - LOCATED ON THE RADIATOR SHROUD.

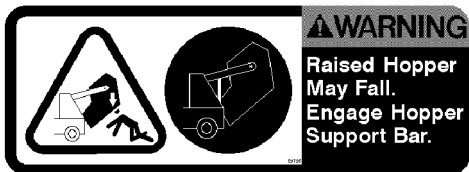
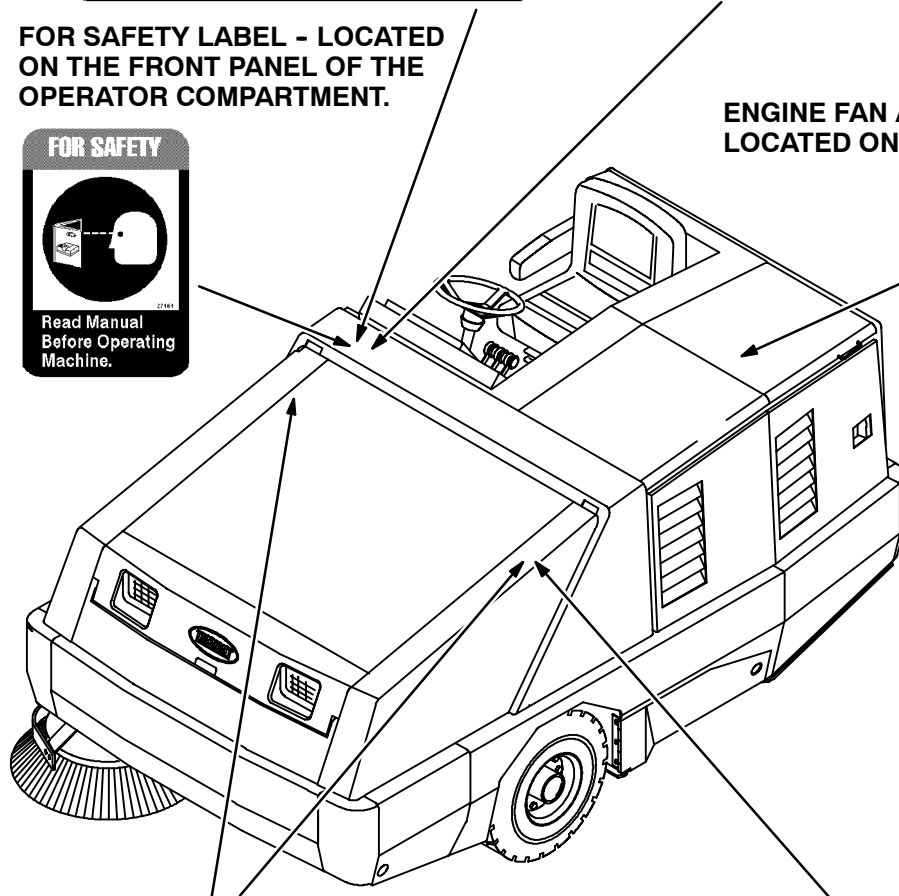

HOPPER SUPPORT BAR LABEL - LOCATED ON THE HOPPER LIFT ARMS CROSS-TUBE AND ON BOTH HOPPER LIFT ARMS.



HOPPER LIFT ARMS LABEL - LOCATED ON BOTH HOPPER LIFT ARMS.

07623

PUSHING, TOWING, AND TRANSPORTING THE MACHINE

PUSHING OR TOWING THE MACHINE

If the machine becomes disabled, it can be pushed from the front or rear, but towed only from the rear.

The propelling pump has a bypass valve to prevent damage to the hydraulic system when the machine is being pushed or towed. This valve allows a disabled machine to be moved for a *very short distance* and at a speed to not exceed 1.6 kp/h (1 mph). The machine is NOT intended to be pushed or towed a long distance or at a high speed.

ATTENTION! Do not push or tow machine for a long distance and without using the bypass valve, or the machine hydraulic system may be damaged.

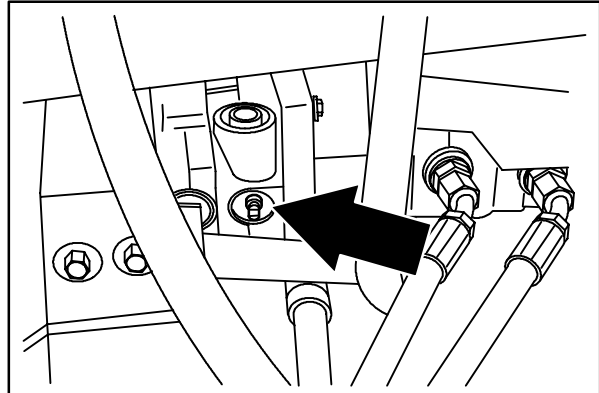

08576

Turn the bypass valve 90° from the normal position before pushing or towing the machine. **The illustration shows the bypass valve in the pushing or towing position.**

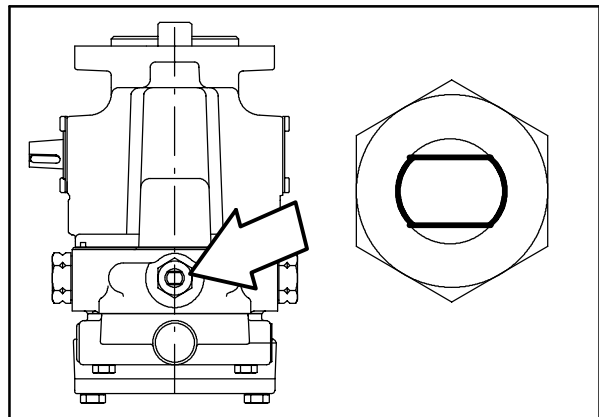

GENERAL INFORMATION

TRANSPORTING THE MACHINE

1. Position the rear of the machine at the loading edge of the truck or trailer.

FOR SAFETY: Use truck or trailer that will support the weight of the machine.

NOTE: Empty the hopper before transporting the machine.

2. If the loading surface is not horizontal or is higher than 380 mm (15 in) from the ground, use a winch to load machine.

If the loading surface is horizontal AND is 380 mm (15 in) or less from the ground, the machine may be driven onto the truck or trailer.

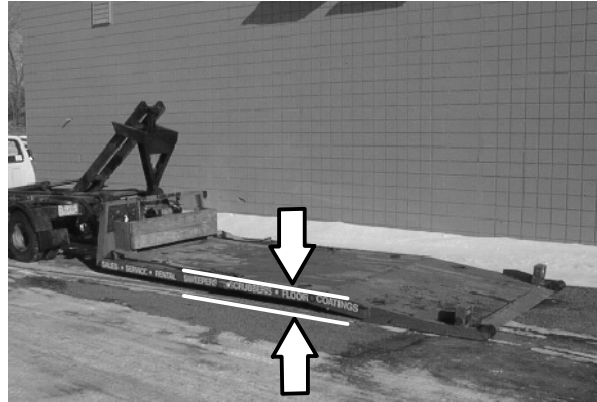

3. To winch the machine onto the truck or trailer, attach the winching chains to the rear tie down locations.

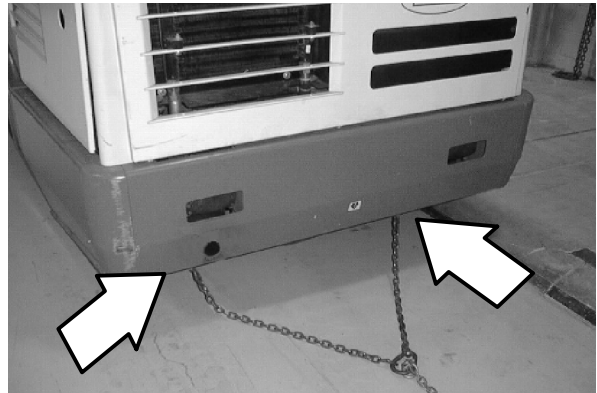

The rear tie-down locations are through the U-bolt section of the main frame under the side bumpers toward the rear.



- Turn the bypass valve 90° from the normal position before winching the machine onto the truck or trailer. See *PUSHING OR TOWING THE MACHINE* section of this manual. Make sure the machine is centered.

FOR SAFETY: When loading machine onto truck or trailer, use winch. Do not drive the machine onto the truck or trailer unless the loading surface is horizontal AND is 380 mm (15 in) or less from the ground.

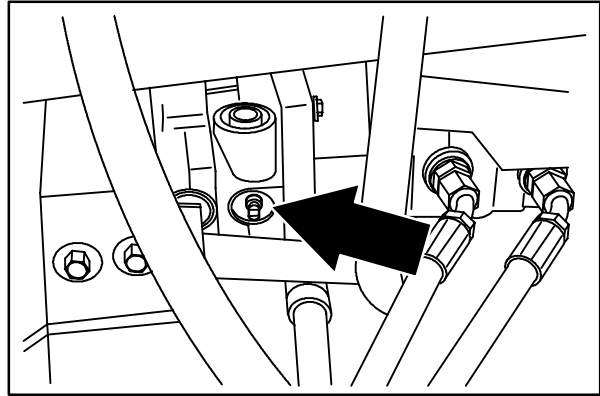

08576

- Position the machine onto the truck or trailer as far as possible. If the machine starts to veer off the centerline of the truck or trailer, stop and turn the steering wheel to center the machine.
- Set the parking brake and block the machine tires. Tie down the machine to the truck or trailer before transporting.

The two front tie-down locations are through the U-bolt section of the main frame in front of the wheels.

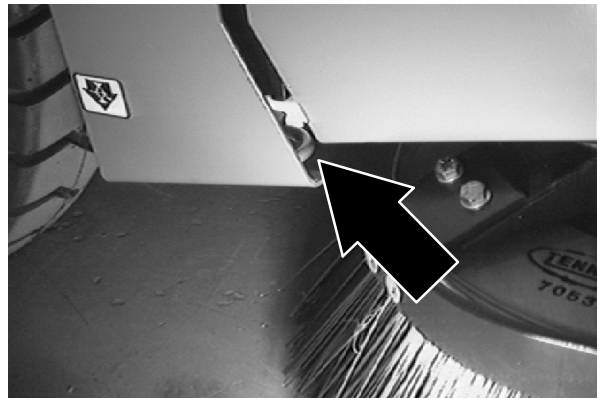

The two rear tie-down locations are through the U-bolt section of the main frame under the side bumpers toward the rear.

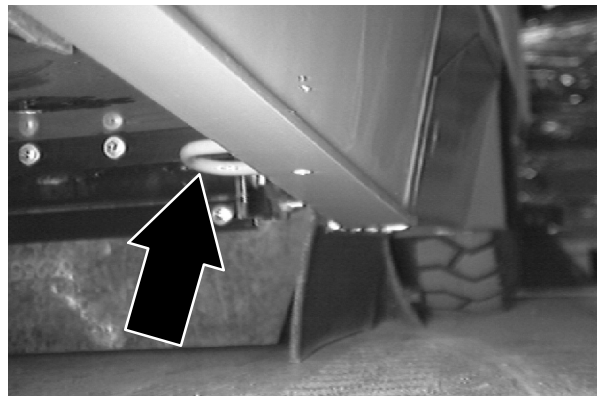

- If the loading surface is not horizontal or is higher than 380 mm (15 in) from the ground, use a winch to unload machine.

If the loading surface is horizontal AND is 380 mm (15 in) or less from the ground, the machine may be driven off the truck or trailer.

FOR SAFETY: When unloading machine off truck or trailer, use winch. Do not drive the machine off the truck or trailer unless the loading surface is horizontal AND 380 mm (15 in) or less from the ground.

GENERAL INFORMATION

MACHINE JACKING

Empty the hopper before jacking the machine. You can jack up the machine for service at the designated locations. Use a jack or hoist that will support the weight of the machine. Always stop the machine on a flat, level surface and block the tires before jacking the machine up.

The front jacking locations are the flat bottom edge of the machine frame next to the front tires.

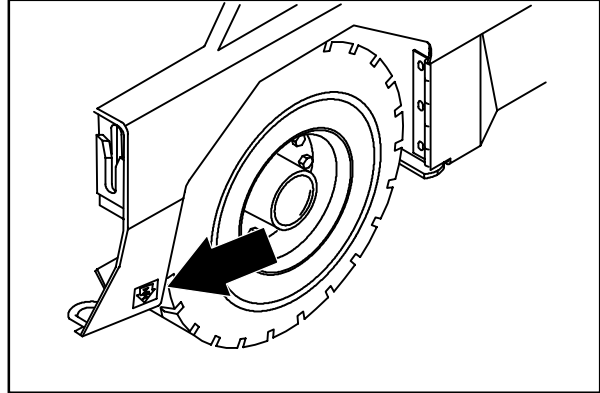

08485

The rear jacking location is the middle of the rear bumper.

FOR SAFETY: When Servicing Machine, Block Machine Tires Before Jacking Machine Up.

FOR SAFETY: When Servicing Machine, Jack Machine Up At Designated Locations Only. Block Machine Up With Jack Stands.

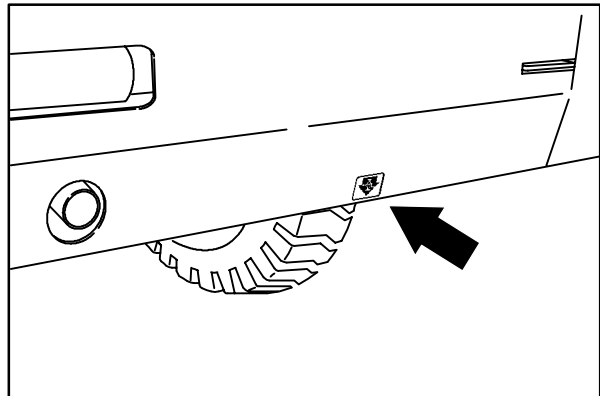

08586

STORING MACHINE

Before storing the machine for an extended period of time, the machine needs to be prepped to lessen the chance of rust, sludge, and other undesirable deposits from forming. Contact TENNANT service personnel.

SPECIFICATIONS

GENERAL MACHINE DIMENSIONS/CAPACITIES

Item	Dimension/capacity
Length	3050 mm (120 in)
Width	1780 mm (70 in)
Height	1335 mm (52.5 in)
Height with overhead guard	2095 mm (82.5 in)
Height with overhead guard and hazard light	2310 mm (91 in)
Height with cab	2095 mm (82.5 in)
Height with cab and hazard light	2310 mm (91 in)
Track	1560 mm (61.5 in)
Wheelbase	1420 mm (56 in)
Main brush diameter	405 mm (16 in)
Main brush length	1270 mm (50 in)
Power Throw™ brush diameter	205 mm (8 in)
Power Throw™ brush length	1170 mm (46 in)
Side brush diameter	65 mm (26 in)
Sweeping path width	1270 mm (50 in)
Sweeping path width with side brush	1675 mm (66 in)
Main brush pattern width	50 to 65 mm (2.0 to 2.5 in)
Hopper weight capacity	907.2 kg (2000 lb)
Hopper volume capacity	849.5 L (30 cu ft)
Dust filter area	17.7 m ² (190 sq ft)
GVWR	4068 kg (8970 lb)
Ceiling height minimum dumping clearance	3355 mm (11 ft)

GENERAL MACHINE PERFORMANCE

Item	Measure
Maximum forward speed	16 kmh15.9 kmh (10 mph)
Maximum reverse speed	7.3 kmh (4.5 mph)
Minimum aisle turn width, left	3450 mm (135 in)
Minimum aisle turn width, right	4675 mm (184 in)
Maximum rated climb and descent angle	8.5°

GENERAL INFORMATION

POWER TYPE: GAS/LP

Engine	Displacement		Net power, governed				Net power, maximum	
Ford LSG 2.3 or Ford LRG 2.3	2300 cc (140 cu in)		37.3 kw (50 hp) @ 2400 rpm				47 kw (63 hp) @ 2800 rpm	
Ford LRG 2.5	2500 cc (152 cu in)		40.3 kw (54 hp) @ 2400 rpm				59 kw (79 hp) @ 3000 rpm	
Ford LSG 2.3 Ford LRG 2.3 and Ford LRG 2.5	Type	Ignition	Cycle	Aspiration	Cyl	Bore	LRG 2.3 Stroke	LRG 2.5 Stroke
	Piston	Breakerless- type spark (LSG) Distributerless- type spark	4	Natural	4	96 mm (3.78 in)	80 mm (3.126 in)	96 mm (3.78 in)
	Fuel		Cooling system			Electrical system		
	Gasoline, 87 octane minimum, unleaded. Fuel tank: 45.5 L (12 gal)		Water/ethylene glycol antifreeze			12 V nominal		
	LPG, Fuel tank: 15 kg (33 lb)		Total: 16.7 L (4.4 gal) Radiator: 6.2 L (1.6 gal)			50 A alternator		
	(Start) governed speed		(Low) governed speed			(High) governed speed		
	1350 ± 50 rpm (LSG) 1475 ± 50 rpm (LRG)		1100 ± 50 rpm (LSG) 2000 ± 50 rpm (LRG)			2400 ± 50 rpm (LSG) 2400 ± 50 rpm (LRG)		
	Spark plug gap					Firing order		
	1 to 1.1 mm (0.042 to 0.046 in)					1-3-4-2		
	Engine lubricating oil with filter (10W30 SAE-SG/SH)							
	4.7 L (5 qt) (LSG) Ford LRG 2.5 - 4.26 L (4.5 qt)					Ford LRG 2.3 - 4.7 L (5 qt)		

POWER TYPE: DIESEL

Engine	Type	Ignition	Cycle	Aspiration	Cylinders	Bore	Stroke
Perkins 200 Series	Piston	Diesel	4	Natural	4	89 mm (3.5 in)	102 mm (4 in)
	Displacement		Net power, governed			Net power, maximum	
	2522 cc (154 cu in)		33.6 kw (45 hp) @ 2400 rpm			44.8 kw (60 hp) @ 3000 rpm	
	Fuel		Cooling system			Electrical system	
	Diesel Fuel tank: 45.5 L (12 gal)		Water/ethylene glycol antifreeze			12 V nominal	
			Total: 13.6 L (3.6 gal)			50 A alternator	
			Radiator: 6.1 L (1.6 gal)				
	Idle speed, no load		Governed speed, under load				
	600 to 650 rpm		2400 ± 50 rpm				
	Engine lubricating oil with filter						
6 L (6.3 qt) 10W30 SAE-CC/CD rated engine oil							

Engine	Type	Ignition	Cycle	Aspiration	Cylinders	Bore	Stroke
Perkins 704-30 Series	Piston	Diesel	4	Natural	4	97 mm (3.8 in)	100 mm (3.9 in)
	Displacement		Net power, governed			Net power, maximum	
	3.0 L. (183 cu in)		44.8 kw (63 hp) @ 2400 rpm			47 kw (63 hp) @ 2400 rpm	
	Fuel		Cooling system			Electrical system	
	Diesel Fuel tank: 45.5 L (12 gal)		Water/ethylene glycol antifreeze			12 V nominal	
			Total: 13.6 L (3.6 gal)			50 A alternator (std) 100 A alternator (HD)	
			Radiator: 6.1 L (1.6 gal)				
	Idle speed, no load		Intermediate speed, under load				Governed speed, under load
	1400 rpm		2000 rpm			2400 ± 50 rpm	
	Engine lubricating oil with filter						
10.4 L (11 qt) with remote filter, 10W30 diesel rating above							

Fuel Consumption: Gas- 1.2 gph
 LPG- 6.6 lb ph
 Diesel-1.4 gph

Oil Pressure: Gas/LP-10 psi at idle, 35 - 40 psi at operating rpm
 Diesel- 7 psi at idle, 29 psi at operating rpm

Vacuum system; CFM - 585 (16565 L / min)

GENERAL INFORMATION

STEERING

Type	Power source	Emergency steering
Rear wheel, hydraulic cylinder and rotary valve controlled	Hydraulic accessory pump	Manual

ELECTRICAL SYSTEM

800/810 Electrical

Battery: Diesel- Group 31, 12V, Cc Amps: 730
Gas/LP-Group 24 12V, Cc Amps: 475

Motors: Shaker motors, 12V,
Normal amp draw-4.5

Starter motor: Diesel, Amp draw cold-
380 @ 10Volts,
Amp draw hot-355 @ 11.5

Starter motor: Gas/LP, Amp draw cold-
185 @ 10Volts
Amp draw hot-155 @ 11.5

Standard alternator: Diesel/Gas/LP,
Output - 50 amps @ 5000 rpm
Volts - 14.5

HYDRAULIC SYSTEM

System	Capacity	Fluid Type
Hydraulic reservoir	47.3 L (12.5 gal)	TENNANT part no. 65869 - above 7° C (45° F)
Hydraulic total	56.8 L (15 gal)	TENNANT part no. 65870 - below 7° C (45° F)

HYDRAULIC PUMPS: CHAR-LYNN

Propelling	23.2 GPM (88 L / min)	4500 PSI Relief (31027 kPa)-Normal throttle
Accessory (brush)	6.2 GPM (23 L / min)	2200 PSI Relief (15170 kPa)-Normal throttle
Accessory (steering)	4.7 GPM (18 L / min)	1300 PSI Relief (8963 kPa)-Normal throttle
Accessory (vacuum)	6.2 GPM (23 L / min)	2000 PSI Relief (13790 kPa)-Normal throttle

HYDRAULIC MOTORS: GAS/LP

Main brush (2 speed), Char-lynn	400 / 500 RPM
Side brush, Char-lynn	100 RPM
Vacuum fan, Barnes	8500 RPM
Propelling, Char-lynn	150 RPM

HYDRAULIC MOTORS: DIESEL

Main brush, Char-lynn	385 RPM
Side brush, Char-lynn	78 RPM
Vacuum fan, Barnes	8500 RPM
Propelling, Char-lynn	150 RPM

BRAKING SYSTEM

Type	Operation
Service brakes	Hydraulic drum brakes (2), one per front wheel, foot brake master cylinder activated
Parking brake	Utilize service brakes, cable actuated

TIRES

Location	Type	Size	Pressure
Front (2)	Pneumatic	6.5 x 23.5 in	690 - 758 kPa (100 - 110 psi)
Rear (1)	Pneumatic	6.5 x 23.5 in	690 - 758 kPa (100 - 110 psi)

GENERAL INFORMATION

MAINTENANCE - GAS/LPG

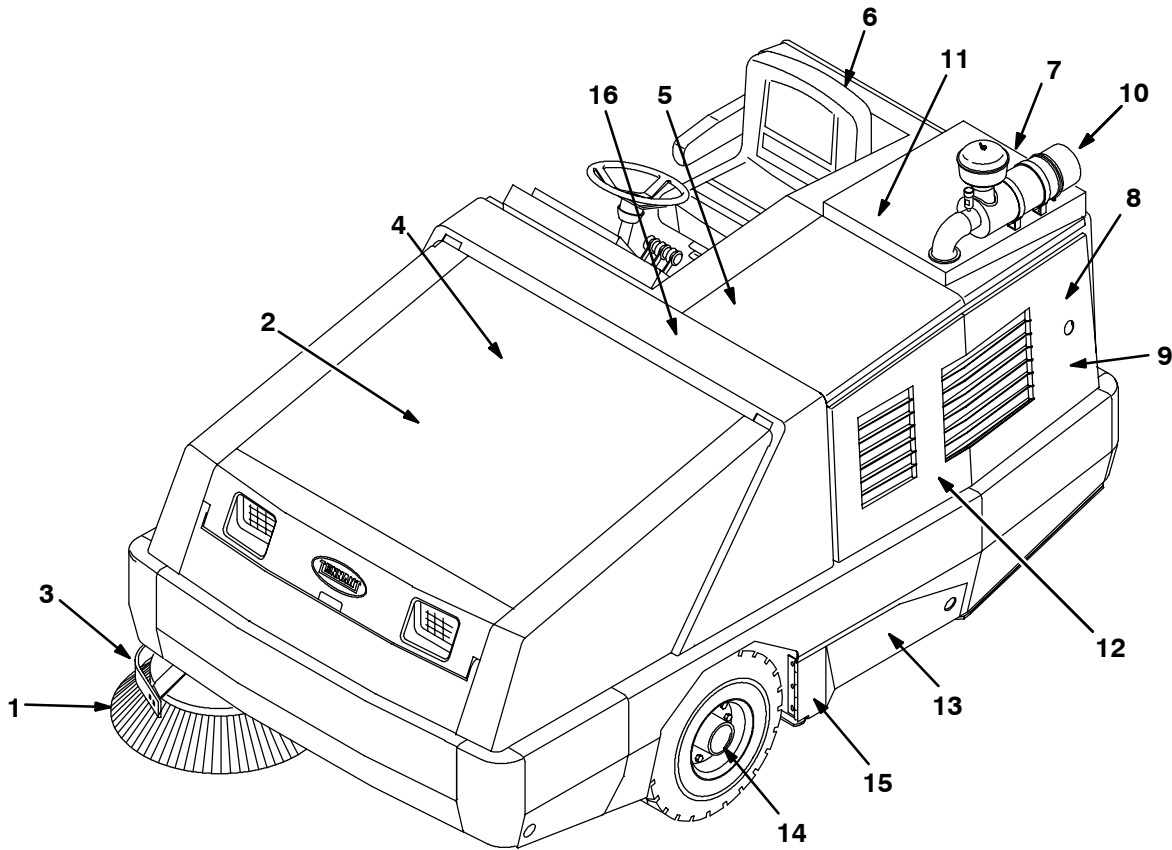

07623

MAINTENANCE CHART

Interval	Key	Description	Procedure	Lubricant/ Fluid	No. of Service Points
Daily	10	Engine air filter	Check indicator	-	1
			Empty dust cap	-	1
	12	Engine crankcase	Check oil level	EO	1
	13	Brush compartment skirts	Check for damage, wear, and adjustment	-	6
	15	Hopper lip skirts	Check for damage, wear, and adjustment	-	3
	13	Main brush	Check for damage, wear, and adjustment	-	1
			Check brush pattern	-	1
	1	Side brush	Check for damage, wear, and adjustment	-	1
Check brush pattern			-	1	
2	Hopper dust filter	Shake	-	2	
50 Hours	13	Main brush	Rotate end-for-end	-	1
	2	Hopper dust filter	Check or clean	-	2
	16	Main brush adjustment	Lubricate	SPL	1

GENERAL INFORMATION

Interval	Key	Description	Procedure	Lubricant/ Fluid	No. of Service Points
100 Hours	6	Hydraulic fluid reservoir	Check fluid level	HYDO	1
	7	Hydraulic fluid cooler	Clean cooler fins		1
	8	Radiator	Clean core exterior		1
			Check coolant level	WG	1
			Clean screen	-	1
	-	Tires	Check pressure	-	3
	13	Main brush & hopper seals	Check for damage or wear	-	12
	12	Engine crankcase	■ Change oil and filter element	EO	1
	12	Engine fan belt	■ Check tension	-	1
	12	Air cond. belt (option)	Check tension	-	1
-	Air cond. filter (option)	Clean or replace if necessary	-	1	
200 Hours	12	Engine	Steam clean exterior	-	1
	8	Radiator hoses and clamps	Check for tightness and wear	-	2
	11	Rear wheel support bearings	Lubricate	SPL	2
	5	Parking brake	Check adjustment	-	1
	3	Side brush pivot pins	Lubricate	SPL	1
400 Hours	12	Engine	Clean or replace and adjust spark plugs	-	1
			Replace PCV valve	-	
			Replace fuel filters, gasoline	-	
	8	Cooling system	Flush	WG	1
4	Brake master cylinder	Check fluid level	BF	1	
800 Hours	6	Hydraulic reservoir	Replace filler cap	GL	
			Replace suction strainer	GL	1
			Change hydraulic fluid	HYDO	1
	9	Hydraulic fluid filter	■ Change filter element	-	1
	12	Engine	Clean PCV hoses, tubes, & fittings	-	1
			Torque intake manifold bolts	-	8
			Check timing belt	-	1
	9	Hydraulic hoses	Check for wear and damage	-	45
	11	Propelling motor	■ Torque shaft nut	-	1
-	Rear wheel	■ Torque wheel nuts	-	1	
16	Battery	■ Clean and tighten battery cable connections	-	1	
1600 Hours	14	Front wheel bearings	Check, lubricate, and adjust	SPL	2
	12	Engine	Replace timing belt	-	1

LUBRICANT/FLUID

BF Brake fluid

EO Engine oil, SAE-SG/SH rated

HYDO . . Tennant Company or approved hydraulic fluid

SPL . . . Special lubricant, Lubriplate EMB grease (TENNANT part no. 01433-1)

WG . . . Water and permanent-type ethylene glycol anti-freeze, -34° C (-30° F)

NOTE: Also check procedures indicted (■) after the first 50-hours of operation.

GENERAL INFORMATION

MAINTENANCE - DIESEL

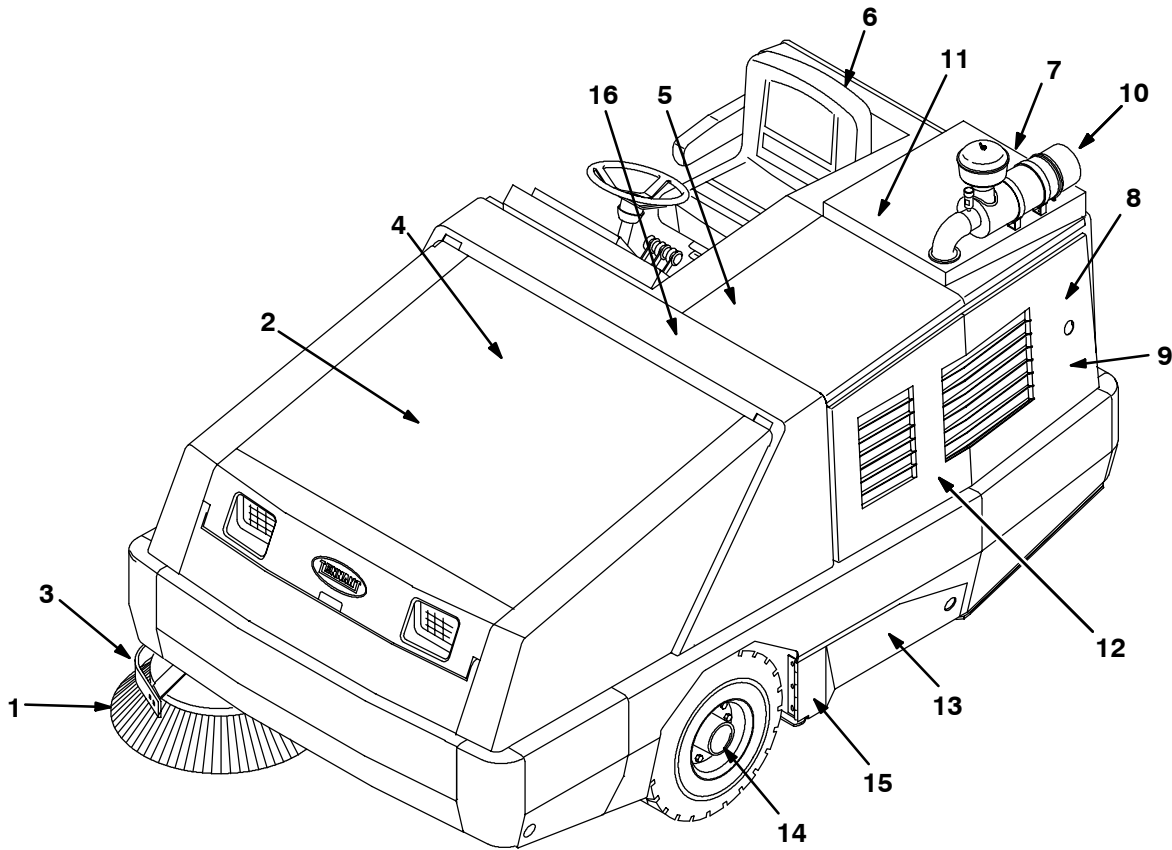

07623

MAINTENANCE CHART

Interval	Key	Description	Procedure	Lubricant/ Fluid	No. of Service Points
Daily	10	Engine air filter	Check indicator	-	1
			Empty dust cap	-	1
	12	Engine crankcase	Check oil level	EO	1
	13	Brush compartment skirts	Check for damage, wear, and adjustment	-	6
	15	Hopper lip skirts	Check for damage, wear, and adjustment	-	3
	13	Main brush	Check for damage, wear, and adjustment	-	1
			Check brush pattern	-	1
	1	Side brush	Check for damage, wear, and adjustment	-	1
Check brush pattern			-	1	
2	Hopper dust filter	Shake	-	2	
50 Hours	13	Main brush	Rotate end-for-end	-	1
	2	Hopper dust filter	Check or clean	-	2
	12	Fuel lines	Check for wear and leaks	-	1
	16	Main brush adjustment	Lubricate	SPL	1

GENERAL INFORMATION

Interval	Key	Description	Procedure	Lubricant/ Fluid	No. of Service Points
100 Hours	6	Hydraulic fluid reservoir	Check fluid level	HYDO	1
	7	Hydraulic fluid cooler	Clean cooler fins		1
	8	Radiator	Clean core exterior		1
			Check coolant level	WG	1
			Clean screen	-	1
	-	Tires	Check pressure	-	3
	13	Main brush & hopper seals	Check for damage or wear	-	12
	12	Engine crankcase	■ Change oil and filter element	EO	1
	12	Engine fan belt	■ Check tension	-	1
	12	Air cond. belt (option)	Check tension	-	1
-	Air cond. filter (option)	Clean or replace if necessary	-	1	
200 Hours	12	Engine	Steam clean exterior	-	1
	8	Radiator hoses and clamps	Check for tightness and wear	-	2
	11	Rear wheel support bearings	Lubricate	SPL	2
	5	Parking brake	Check adjustment	-	1
	3	Side brush pivot pins	Lubricate	SPL	1
400 Hours	12	Fuel filter, Engine	Replace	-	1
	12	Water separator / fuel filter	Replace	-	1
	8	Cooling system	Flush	WG	1
	4	Brake master cylinder	Check fluid level	BF	1
800 Hours	6	Hydraulic reservoir	Replace filler cap	GL	
			Replace suction strainer	GL	1
			Change hydraulic fluid	HYDO	1
	9	Hydraulic fluid filter	■ Change filter element	-	1
	9	Hydraulic hoses	Check for wear and damage	-	49
	11	Propelling motor	■ Torque shaft nut	-	1
	-	Rear wheel	■ Torque wheel nuts	-	1
16	Battery	■ Clean and tighten battery cable connections	-	1	
1600 Hours	14	Front wheel bearings	Check, lubricate, and adjust	SPL	2

LUBRICANT/FLUID

BF Brake fluid

EO Engine oil, 10W30 diesel rating above CD grade only

HYDO . . Tennant Company or approved hydraulic fluid

SPL . . . Special lubricant, Lubriplate EMB grease (TENNANT part no. 01433-1)

WG . . . Water and permanent-type ethylene glycol anti-freeze, -34° C (-30° F)

NOTE: Also check procedures indicted (■) after the first 50-hours of operation.

GENERAL INFORMATION

HARDWARE INFORMATION

The following charts state standard plated hardware tightening ranges for normal assembly applications. Decrease the specified torque by 20% when using a thread lubricant. Do not substitute lower grade hardware for higher grade hardware. If higher grade hardware than specified is substituted, tighten only to the specified hardware torque value to avoid damaging the threads of the part being threaded into, as when threading into speed nuts or weldments.

STANDARD BOLT TORQUE CHART

Thread Size	SAE Grade 5 Torque ft lb (Nm)	SAE Grade 8 Torque ft lb (Nm)
0.25 in	7-10 (9-14)	10-13 (14-38)
0.31 in	15-20 (20-27)	20-26 (27-35)
0.38 in	27-35 (37-47)	36-47 (49-64)
0.44 in	43-56 (58-76)	53-76 (72-103)
0.50 in	65-85 (88-115)	89-116 (121-157)
0.62 in	130-170 (176-231)	117-265 (159-359)
0.75 in	215-280 (291-380)	313-407 (424-552)
1.00 in	500-650 (678-881)	757-984 (1026-1334)





NOTE: Decrease torque by 20% when using a thread lubricant.

METRIC BOLT TORQUE CHART

Thread Size	Class 8.8 Torque ft lb (Nm)	Class 10.9 Torque ft lb (Nm)
M4	2 (3)	3 (4)
M5	4 (5)	6 (8)
M6	7 (9)	10 (14)
M8	18 (24)	25 (34)
M10	32 (43)	47 (64)
M12	58 (79)	83 (112)
M14	94 (127)	133 (180)
M16	144 (195)	196 (265)
M20	260 (352)	336 (455)
M24	470 (637)	664 (900)

NOTE: Decrease torque by 20% when using a thread lubricant.

BOLT IDENTIFICATION

Identification Grade Marking	Specification and Grade
	SAE-Grade 5
	SAE-Grade 8
	ISO-Grade 8.8
	ISO-Grade 10.9

THREAD SEALANT AND LOCKING COMPOUNDS

Thread sealants and locking compounds may be used on this machine. They include the following:

Loctite 515 sealant - gasket forming material. TENNANT Part No. 75567, 15 oz (440 ml) cartridge.

Loctite 242 blue - medium strength thread locking compound. TENNANT Part No. 32676, 0.5 ml tube.

Loctite 271 red - high strength thread locking compound. TENNANT Part No. 19857, 0.5 ml tube.

CONTENTS

	Page
CHASSIS	2-3
SEAT	2-3
TO REMOVE SEAT ASSEMBLY	2-3
TO REPLACE SEAT ASSEMBLY	2-3
TO ADJUST SEAT POSITION	2-4
TO ADJUST SEAT RIDE STIFFNESS	2-4
STATIC DRAG CHAIN	2-4
BRAKES AND TIRES	2-5
SERVICE BRAKES	2-5
TO REPLACE BRAKE SHOES	2-5
TO ADJUST BRAKES	2-7
FRONT TIRES AND WHEELS	2-8
TO REPACK FRONT WHEEL BEARINGS	2-8
PARKING BRAKE (FOOT ACTIVATED)	2-9
TO ADJUST FOOT ACTIVATED BRAKE	2-9
PARKING BRAKE (HAND ACTIVATED)	2-9
TO ADJUST HAND ACTIVATED BRAKE	2-9
REAR TIRE AND WHEEL, AND WHEEL SUPPORT	2-10
TO REPLACE REAR WHEEL HOUSING PIVOT BEARINGS ...	2-11

CHASSIS

This section includes information on the main chassis related components for example the seat, steering, brakes and tires.

SEAT

The seat assembly is removable on both the 800 and the 810. The seat can also be adjusted on both models. Tools are needed to remove the seat.

FOR SAFETY: Before Leaving Or Servicing Machine; Stop On Level Surface, Set Parking Brake, Turn Off Machine And Remove Key.

TO REMOVE SEAT ASSEMBLY

1. Tilt the seat assembly forward and hold it in this position.
2. Remove the M6 hex screw and nyloc nut holding the prop rod to the seat bottom.
3. Set the seat back down.
4. Remove the two M8 hex bolts, washers, and sleeves from the front of the seat.
5. Lift the seat assembly out of the machine.

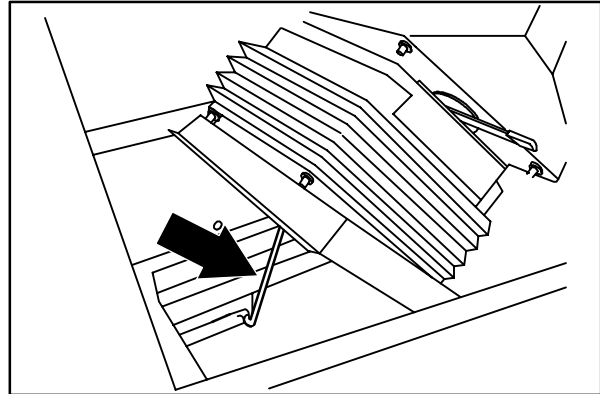

TO REPLACE SEAT ASSEMBLY

1. Position the seat assembly back on the machine.
2. Install the two sleeves, washers, and M8 hex bolts. Hand tighten.
3. Tilt the seat assembly forward and hold it in this position.
4. Reinstall the seat prop rod to the bottom of the seat using the M6 hex screw, nyloc nut, and washers. Hand tighten until snug.
5. Lower the seat.

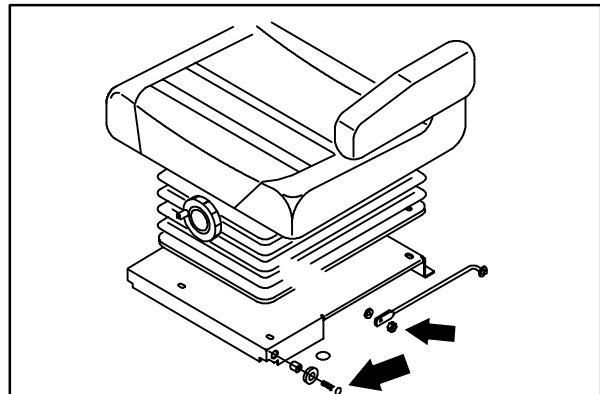

CHASSIS

TO ADJUST SEAT POSITION

1. Pull adjustment lever forward, located lower left side of seat
2. Move seat to desired position.
3. Release adjustment lever.

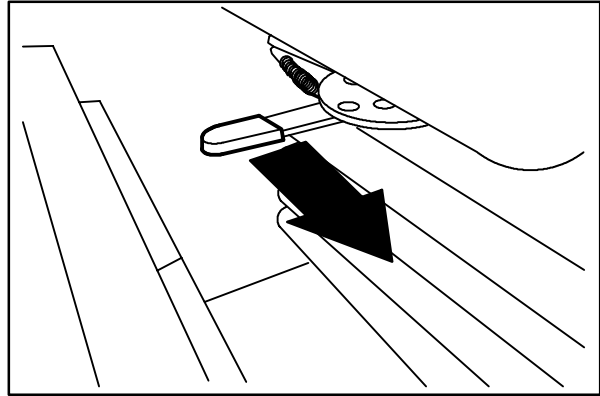

08443

TO ADJUST SEAT RIDE STIFFNESS

1. Turn knob (located in front of seat) clockwise to increase ride stiffness, counter-clockwise to decrease ride stiffness.

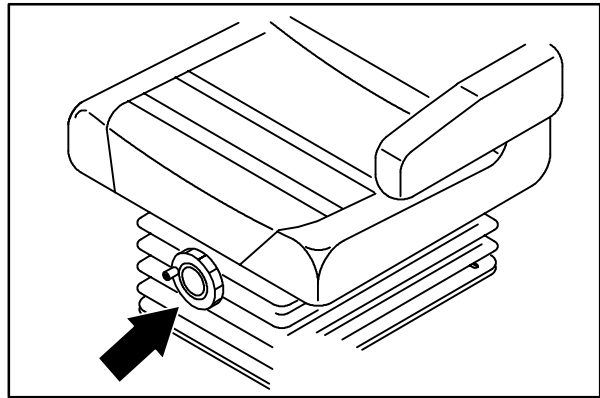

STATIC DRAG CHAIN

A static drag chain prevents the buildup of static electricity in the machine. The chain is attached to the machine by a rear main brush skirt retaining bolt.

Make sure the chain is touching the floor at all times.

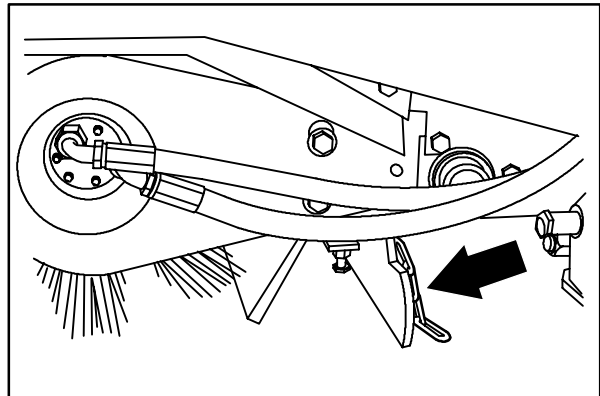

08449

BRAKES AND TIRES

SERVICE BRAKES

The hydraulic service brakes are located on the front wheels. The brakes are operated by the foot brake pedal.

Check the brake adjustment every 200 hours of operation.

TO REPLACE BRAKE SHOES

FOR SAFETY: Before Leaving Or Servicing Machine; Stop On Level Surface, Set Parking Brake, Turn Off Machine And Remove Key.

1. Jack up one front corner of the machine.
Place a jack stand under machine.

FOR SAFETY: Block machine tires before jacking machine up. Jack machine up at designated locations only. Block machine up with jack stands.

2. Remove the six wheel nuts and the tire/wheel assembly.
3. Remove the small hub cap from the center of the brake drum.
4. Remove the cotter pin, slotted nut, flat washer, and bearing cone.
5. Slide the brake drum off the axle.
6. Remove the springs holding the brake shoes together.
7. Remove the retainer clips holding the brake shoes to the backing plate. Remove and discard the old shoes.
8. Position the new brake shoes onto the backing plate.
9. Reinstall the retainer clips.

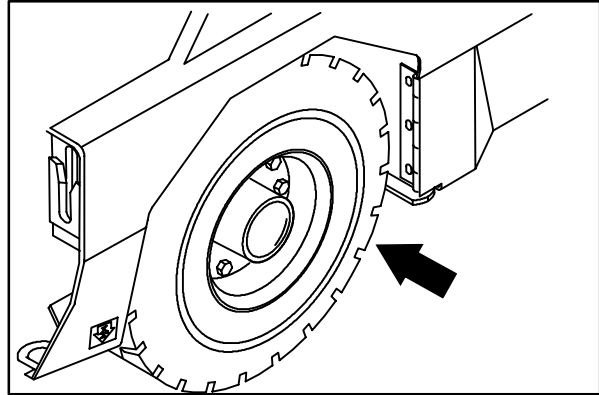

08579

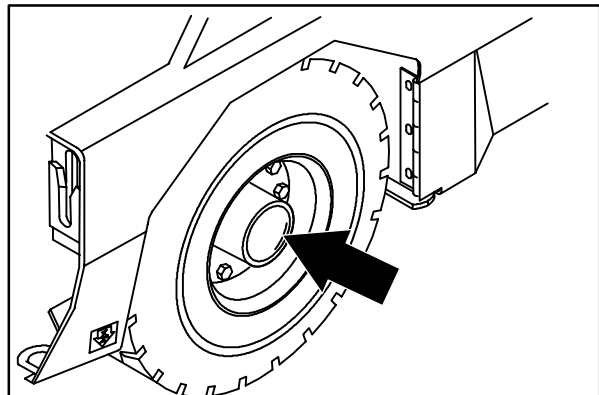

08579

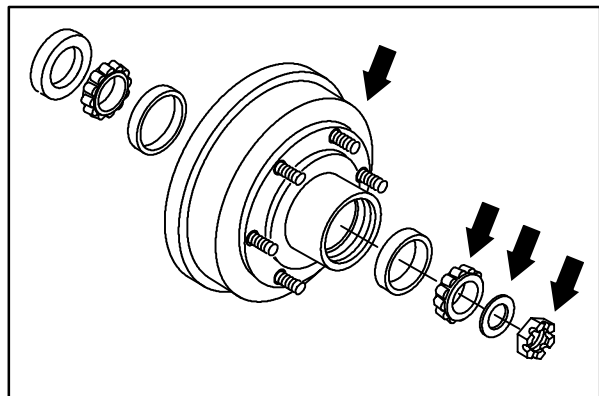

CHASSIS

10. Reconnect brake springs to brake shoes.
11. Pack the wheel bearings with Lubriplate EMB grease.
12. Slide the brake drum back on the axle.
13. Slide the outer bearing, flat washer and nut onto the shaft.
14. Tighten nut with hand wrench until wheel binds, then back nut off to nearest hole.
15. Insert a new cotter pin through nut and hole.
16. After making sure the wheel spins freely, carefully install the small center cap.
17. Reinstall tire and wheel assembly. Tighten the six wheel nuts to 95 - 115 Nm (70 - 85 ft lb).
18. Remove the jack stands and lower the machine.

NOTE: Always replace brake shoes in sets.

19. Repeat the procedure on the other wheel.

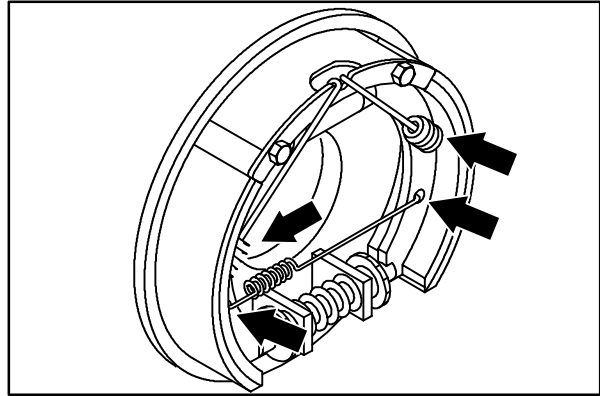

TO ADJUST BRAKES

FOR SAFETY: Before Leaving Or Servicing Machine; Stop On Level Surface, Set Parking Brake, Turn Off Machine And Remove Key.

1. Jack up one front corner of the machine.
Place a jack stand under machine.

FOR SAFETY: Block machine tires before jacking machine up. Jack machine up at designated locations only. Block machine up with jack stands.

2. Remove the six wheel nuts and the tire/wheel assembly.
3. Remove the small hub cap from the center of the brake drum.
4. Remove the cotter pin, slotted nut, flat washer, and bearing cone.
5. Slide the brake drum off the axle.
6. Turn adjustment wheel located at bottom of brake shoes until drum fits snugly over brake shoes.
7. Slide the brake drum back on the axle.
8. Slide the outer bearing, flat washer and nut onto the shaft.
9. Tighten nut with hand wrench until wheel binds, then back nut off to nearest hole.
10. Insert a new cotter pin through nut and hole.
11. After making sure the wheel spins freely, carefully install the small center cap.
12. Reinstall tire and wheel assembly. Tighten the six wheel nuts to 95 - 115 Nm (70 - 85 ft lb).
13. Remove the jack stands and lower the machine.
14. Operate the machine and check the brake pedal for proper adjustment.

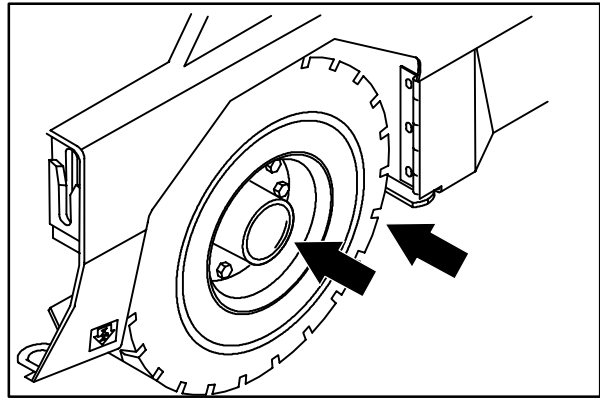

08579

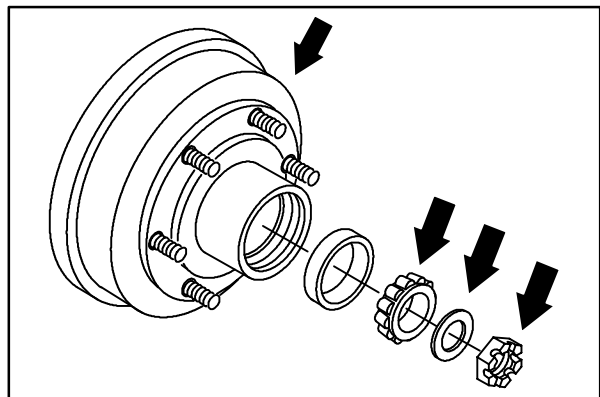
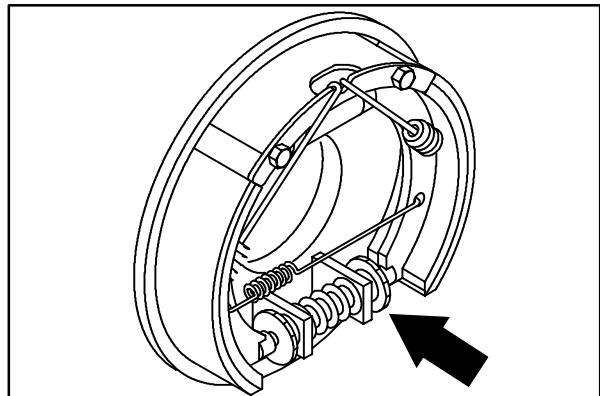

CHASSIS

FRONT TIRES AND WHEELS

The standard machine tires are pneumatic.

inspect the front wheel bearings for seal damage, and repack and adjust every 1600 hours of operation. Use Lubriplate EMB grease (TENNANT part no. 01433-1).

TO REPACK FRONT WHEEL BEARINGS

FOR SAFETY: Before Leaving Or Servicing Machine; Stop On Level Surface, Set Parking Brake, Turn Off Machine And Remove Key.

1. Jack up one front corner of the machine.
Place a jack stand under machine.

FOR SAFETY: Block machine tires before jacking machine up. Jack machine up at designated locations only. Block machine up with jack stands.

2. Remove the six wheel nuts and the tire/wheel assembly.
3. Remove the small hub cap from the center of the brake drum.
4. Remove the cotter pin, slotted nut, flat washer, and bearing cone.
5. Slide the brake drum off the axle.
6. Pack the wheel bearings with Lubriplate EMB grease.
7. Slide the brake drum back on the axle.
8. Slide the outer bearing, flat washer and nut onto the shaft.
9. Tighten nut with hand wrench until wheel binds, then back nut off to nearest hole.
10. Insert a new cotter pin through nut and hole.
11. After making sure the wheel spins freely, carefully install the small center cap.
12. Reinstall tire and wheel assembly. Tighten the six wheel nuts to 95 - 115 Nm (70 - 85 ft lb).
13. Remove the jack stands and lower the machine.

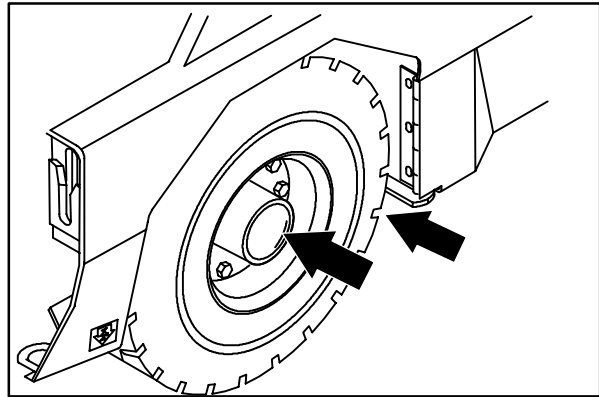

08579

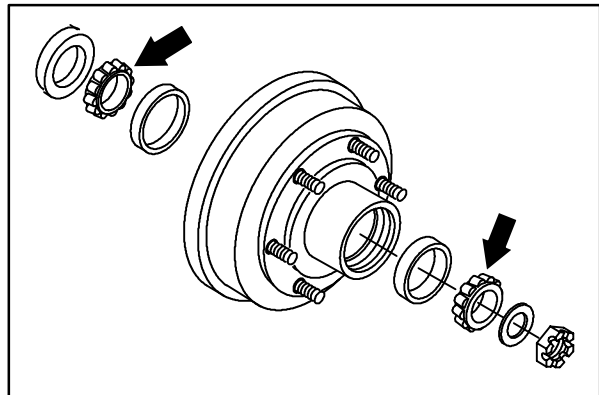

PARKING BRAKE (FOOT ACTIVATED)

The parking brake is set with foot pedal on machines with serial numbers (0 - 1102) on model 800 and (0 - 2045) on model 810.

Adjust the parking brake whenever it becomes very easy to set, when the machine rolls after setting the parking brake, and after every 200 hours of operation.

Adjust the parking brake so it will hold the Machine on a smooth 8 degree incline.

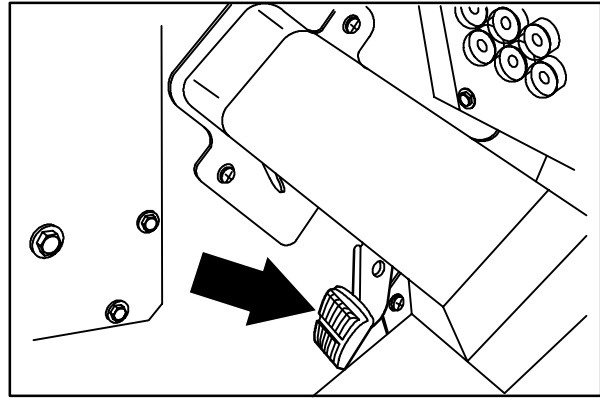

08574

TO ADJUST FOOT ACTIVATED BRAKE

1. Loosen 2 jam nuts on threaded rod connected to brake pedal.
2. Turn rod either clockwise or counter-clockwise to increase or decrease the tension on cables.
3. Once rod is at the correct length where the brakes hold the machine, tighten the jam nuts on the rod.

PARKING BRAKE (HAND ACTIVATED)

The parking brake is set with a hand lever on machines with serial numbers (1103 and up) on model 800 and (2046 and up) on model 810.

Adjust the parking brake whenever it becomes very easy to set, when the machine rolls after setting the parking brake, and after every 200 hours of operation

Adjust the parking brake so it will hold the Machine on a smooth 8 degree incline.

**TO ADJUST HAND ACTIVATED BRAKE**

1. At the end of the handle, there is a knob that can be turned clockwise or counter-clockwise.
2. Release the parking brake and turn knob to increase or decrease the tension on the brake cables. Set the parking brake to test readjust as necessary.
3. Adjust this knob until the brakes sufficiently hold the machine in place.

CHASSIS

REAR TIRE AND WHEEL, AND WHEEL SUPPORT

The rear wheel support pivots the rear wheel. The support has one grease fitting for the bearings. The rear wheel support bearings must be lubricated every 200 hours of operation. Use Lubriplate EMB grease (TENNANT part no. 01433-1).

Check the rear tire pressure every 100 hours of operation. The proper tire air pressure is 690 - 758 kPa (100 - 110 psi).

Torque the rear wheel nuts to 122 - 142 Nm (90 - 105 ft lb) after the first 50-hours of operation, and every 800 hours thereafter.

Torque the rear wheel hub nut to 270 - 340 Nm (200 - 250 ft lb).

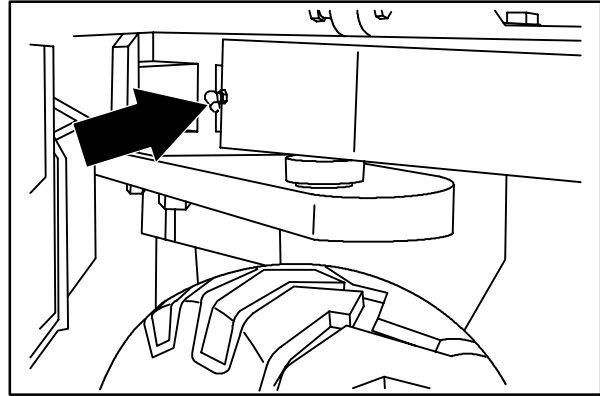

08451

TO REPLACE REAR WHEEL HOUSING PIVOT BEARINGS

FOR SAFETY: Before Leaving Or Servicing Machine; Stop On Level Surface, Set Parking Brake, Turn Off Machine And Remove Key.

1. Engage the parking brake, block the front tires.

FOR SAFETY: Block machine tires before jacking machine up. Jack machine up at designated locations only. Block machine up with jack stands.

2. Jack up the rear of machine. Use jack stands to support the machine.
3. Remove the rear tire and wheel assembly.
4. Turn steering wheel clockwise as far as it will go so the steering cylinder is completely retracted.
5. Disconnect the battery cables from machine.



WARNING: Always disconnect battery cables from machine before working on or near electrical components.

6. Remove the seat assembly from the machine. See TO REMOVE SEAT ASSEMBLY instructions in this section.
7. Remove the access cover panel from the operator's compartment to gain access to steering bracket.
8. Remove the hose clamp, channel, sleeve and hardware from the steering bracket.
9. Remove the hex screw and nyloc nut holding the ball joint to the rear casting.
10. Remove and plug the hydraulic hoses from the drive motor. Mark the hoses for proper assembly orientation.

NOTE: Observe hydraulic cleanliness requirements when opening hydraulic lines.

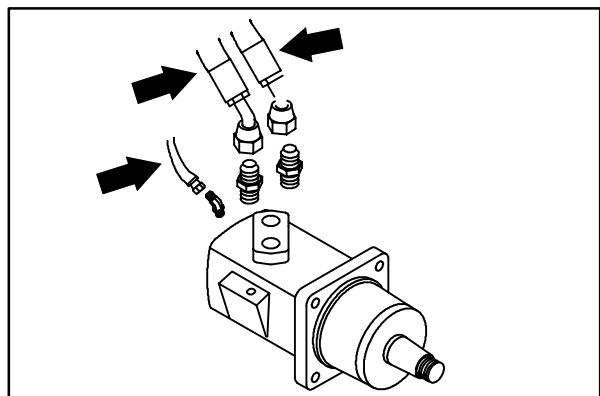
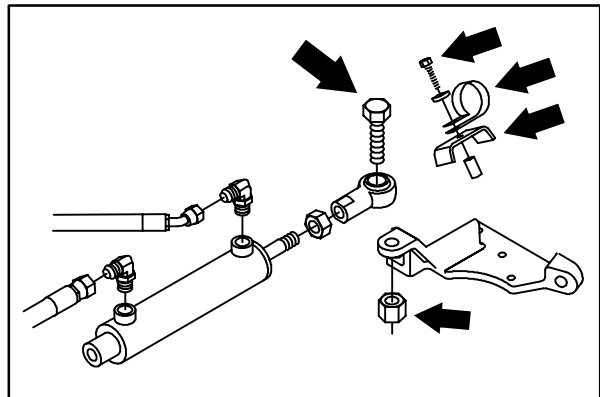
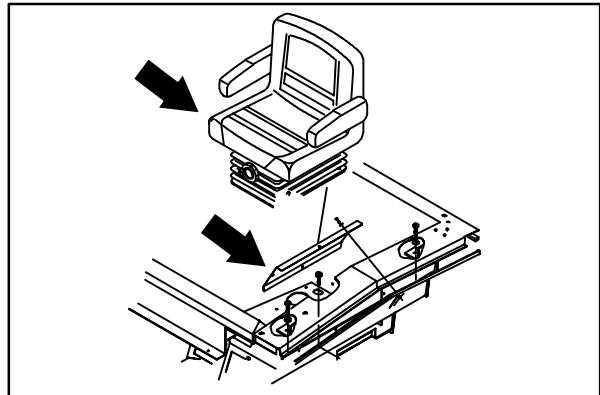
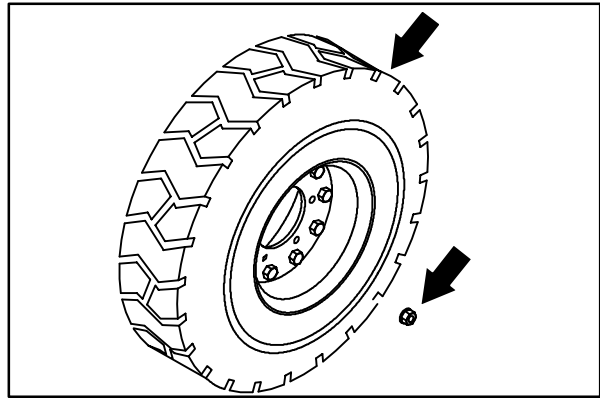

CHASSIS

11. Place a floor jack under the rear wheel support. Raise the wheel support until the weight is removed from the support bearings. Do not lift the machine off the jack stands.
12. Remove the lock ring retainer by first loosening the retainer's 12 cap screws. Thread three of the cap screws in the three open threaded holes. This will drive the ring retainer off the shaft. After the ring is off the shaft, return the three cap screws to their original threaded holes.
13. Remove the bottom pivot plate bolts and the pivot plate. Count the number of threads exposed below slotted nut on pivot shaft.
14. Remove the slotted nut and tabbed lock washer. Save the slotted nut and the tabbed lock washer.
15. Remove the washer and bearing cone. Discard the washer.
16. Lower the drive housing and remove it from under the machine.
17. The upper bearing cone is pressed on. A bearing puller must be used to remove it. Removal of the upper bearing mount plate will make this easier.
18. Pre-grease the new bearing cone and press on shaft. Reinstall upper bearing mount plate if removed. Tighten the five M20 hex screws to 300 - 390 Nm (220 - 290 ft lb).
19. Place the rear drive housing back under the machine. Raise the housing back in position with the floor jack.

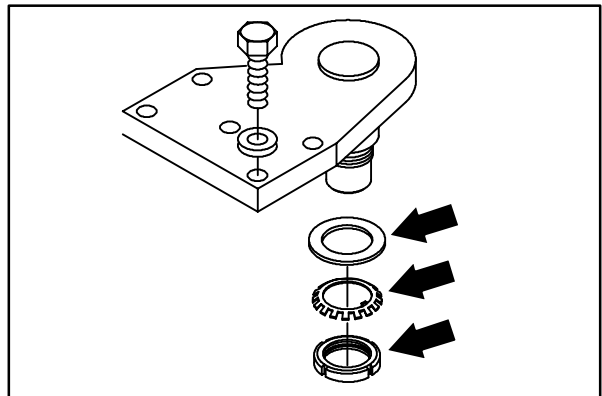
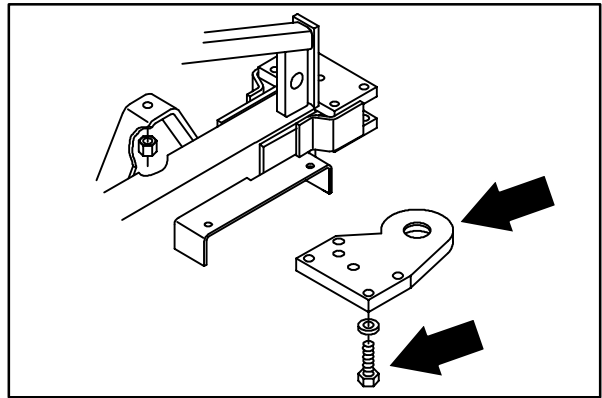
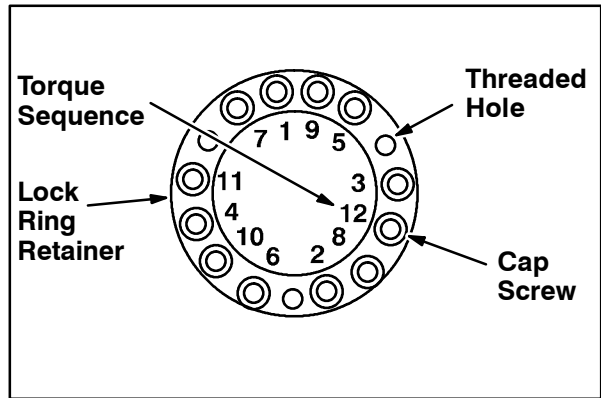

20. Pre-grease the second bearing cone and install with a new hardened washer, tab lock washer, and slotted nut. Lubricate the face of the tab lock washer so the locking nut can turn freely.
21. Tighten the slotted nut by rocking the casting back and forth. Torque slotted nut to 68 Nm (50 ft lb). Then tighten nut another 1/8 turn. Bend tabs on washer to lock slotted nut.
22. Reinstall the bottom pivot plate. Only **HAND TIGHTEN** the hex screws at this time.
23. Slide the lock ring retainer into place on the pivot shaft. This will center bottom plate to pivot shaft. Do not tighten at this time.
24. Hold the lock ring retainer in place while tightening the five M20 hex screws to 300 - 390 Nm (220 - 290 ft lb) on the bottom pivot plate.
25. Alternately tighten the cap screws. Torque cap screws to 14 Nm (10 ft lb), then to 28 Nm (20 ft lb), and then to 40 Nm (30 ft lb) in the pattern shown.
26. Remove the floor jack from under the rear wheel support.
27. Reconnect the hydraulic hoses. Make sure each hose is placed on the fitting it was removed from.

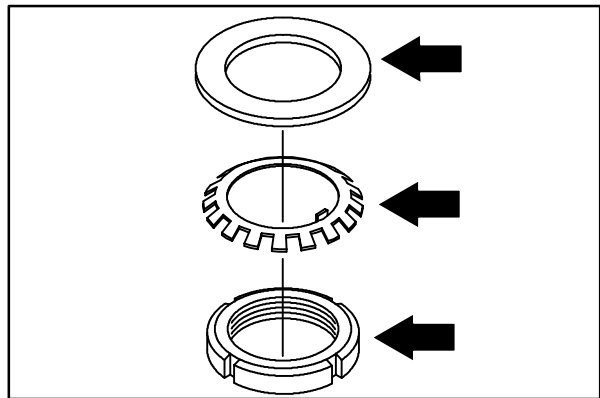
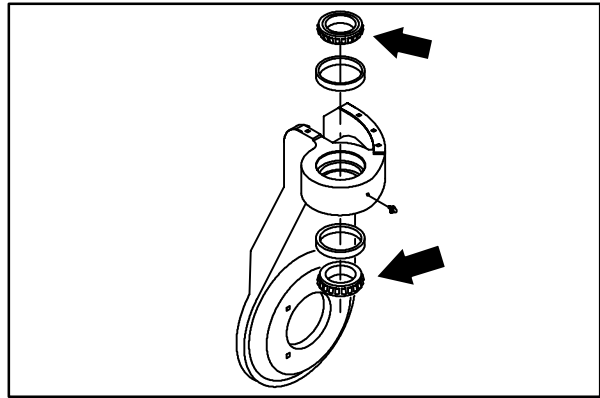

NOTE: Observe hydraulic cleanliness requirements when opening hydraulic lines.

28. Install the hydraulic cylinder ball joint on steering bracket. Torque the hex screw to 290 - 380 Nm (215 - 280 ft lb).

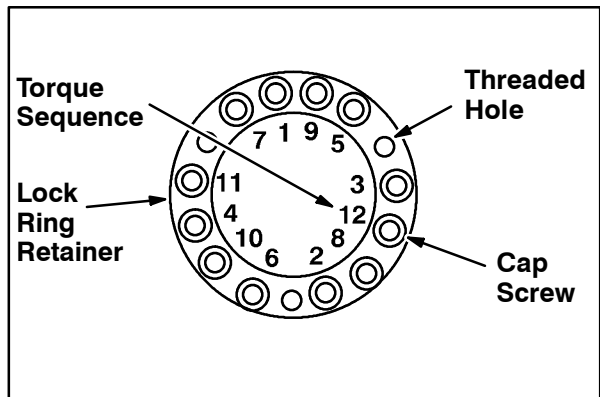

CHASSIS

29. Install existing hose clamp, channel and sleeve on steering bracket with existing hardware.
30. Reinstall the rear tire and wheel assembly. Tighten the six wheel nuts to 122 - 142 Nm (90 - 105 ft lb). Use a crisscross pattern when torquing wheel nuts.
31. Remove the machine jack stands and lower the machine to the floor.
32. Rock the machine side to side and listen for a clicking sound from the rear wheel support. If you hear the sound, repeat steps 11 - 25.
33. Reinstall access cover panel in operator's compartment.
34. Reinstall seat assembly. See TO REPLACE SEAT ASSEMBLY instructions in this section.
35. Reconnect the battery cables.
36. Operate the machine and check for proper operation of the rear drive area.

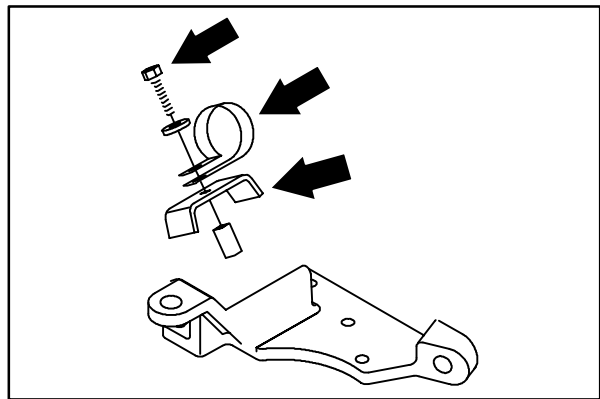
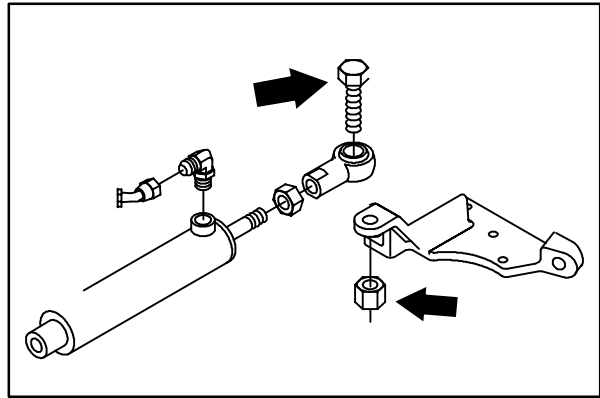

CONTENTS

	Page		Page
INTRODUCTION	3-3	SKIRTS AND SEALS	3-24
REGENERATIVE FILTER SYSTEM		TO REPLACE HOPPER LIP	
(RFS)	3-4	SKIRTS	3-24
DEBRIS HOPPER	3-5	BRUSH COMPARTMENT SKIRTS ..	3-25
TO REMOVE HOPPER	3-5	TO REPLACE AND ADJUST BRUSH	
TO INSTALL HOPPER	3-7	DOOR SKIRTS	3-25
TO ADJUST AND LEVEL HOPPER		REAR SKIRTS	3-26
HEIGHT	3-7	TO REPLACE AND ADJUST THE	
HOPPER DUMP DOOR	3-8	REAR SKIRT	3-26
TO REMOVE HOPPER DUMP		TO REPLACE AND ADJUST THE	
DOOR	3-8	REAR DEFLECTOR SKIRT	3-27
TO INSTALL HOPPER DUMP		BRUSH DOOR SEALS	3-28
DOOR	3-9	HOPPER SEALS	3-28
TO ADJUST HOPPER DUMP		TO REPLACE HOPPER WHEEL	
DOOR	3-9	POCKET SEALS	3-29
HOPPER DUST FILTER	3-10	HOPPER DOOR SEALS	3-30
TO REMOVE OR REPLACE HOPPER		HOPPER SIDE SKIRT	3-30
DUST FILTER	3-10	HOPPER DUST SEAL	3-30
THERMO SENTRY™	3-12	HOPPER COVER SEAL	3-30
TO REPLACE THERMO SENTRY™	3-12	HOPPER LIFT ARMS	3-31
BRUSHES	3-13	TO REMOVE HOPPER LIFT ARM ..	3-31
MAIN BRUSH	3-13	TO INSTALL HOPPER LIFT ARM ...	3-32
TO REPLACE MAIN BRUSH	3-13	HOPPER VACUUM FAN SEAL	3-33
TO CHECK AND ADJUST MAIN		VACUUM FAN	3-33
BRUSH PATTERN	3-14	TO REPLACE VACUUM FAN	
TO REPLACE MAIN BRUSH IDLER		IMPELLER	3-33
PLUG BEARING	3-16	MACHINE TROUBLESHOOTING	3-36
TO REPLACE MAIN BRUSH SHAFT			
BEARINGS	3-17		
POWER THROW™	3-19		
TO REPLACE POWER			
THROW™ BRUSH	3-19		
TO REPLACE POWER THROW™			
BRUSH IDLER BEARINGS	3-20		
SIDE BRUSH	3-21		
TO REPLACE SIDE BRUSH	3-21		
TO ADJUST SIDE BRUSH TIP			
ANGLE	3-22		
TO ADJUST SIDE BRUSH RIDE			
HEIGHT	3-23		

INTRODUCTION

The side brush sweeps debris into the path of the main brush. The main brush sweeps debris from the floor into the hopper. The vacuum system pulls dust and air through the hopper and the hopper dust filter.

REGENERATIVE FILTER SYSTEM (RFS)

The Regenerative Filter System (RFS) is an option that alternately turns on the filter shaker motors when the filters need cleaning because of a build-up of dust or debris.

Normally the RFS does not require the operator to stop the machine to shake the filters during sweeping operation (except in extreme and severe dust environments). However, it is recommended that the filters are shaken at the operator's initiative each time the hopper is dumped. This can be accomplished during transit to a dump sight. **AVOID** shaking the filters while hopper is in a rolled out position. To initiate a shaking cycle, press the filter button on the instrument panel.

In very severe dust environments, the plugged filter indicator on the instrument panel may remain lit. When this occurs, it is recommended that the operator stop the machine and initiate one or two shake cycles to clear a possible plugged filter condition. After shaking, roll the hopper out to evacuate the dust tray. Resume sweeping operation.

If the hopper is over full, the light may come on. Check the hopper load and dump if necessary.

If the filter light remains on after all the above conditions are corrected, the filters may be plugged or the RFS may be inoperative. Filters may be shaken by the operator initiative by pressing the filter button on the instrument panel if there is a failure in the RFS control system.

Successful operation of the RFS option requires clean, undamaged filters. Plugged filters may cause the RFS to cycle continuously even at start up. The option also requires good sealing of the upper lid to the hopper, as well as a good seal between the two upper filter chambers.

It is recommended that the machine be driven for some test sweeping with the RFS option at initial start up. This next step assumes the hopper cover and upper filter chamber of the hopper was cleaned thoroughly prior to installation of the RFS option. Sweep for 30 minutes and open the hopper cover to check the integrity of the seals. Look at the top of the shaker panels and the underside of the hopper cover. Check for any signs of *dust tracking* that may be caused by a bad seal or filter. Repair as necessary. Perform this check periodically while using the sweeper with the RFS option.

DEBRIS HOPPER

The debris hopper collects the debris swept up by the main brush. The hopper includes the following main components: hopper dust filters, hopper dump door, and dust skirts. All adjustments have been made at the factory and require no regular maintenance. If the hopper components are repaired or replaced, some components may need to be re-adjusted for best performance. The hopper may need to be removed from the machine for some repair or service work.

TO REMOVE HOPPER

FOR SAFETY: Before Leaving Or Servicing Machine; Stop On Level Surface, Set Parking Brake, Turn Off Machine And Remove Key.

1. Make sure the hopper has been emptied of all debris.
2. Set the parking brake, Raise the hopper and engage the prop arm.



WARNING: Raised Hopper May Fall. Engage Hopper Support Bar.

3. Remove the two M8 hex screws holding each fender to the hopper bumper. Disengage the prop arm and lower the hopper.
4. Open hopper cover and remove eight M8 hex screws attaching LH and RH fenders to hopper.
5. Open the front headlight panel. Spread the front fenders apart and pull the headlight panel out of the hole on each end.
6. Remove the headlight panel and both front fenders from the machine.
7. Start the machine and open hopper dump door.
8. Remove the two M10 hex screws from the bottom front corners of the hopper.
9. Remove the five M10 hex screws from both sides of hopper. (accessed inside hopper)

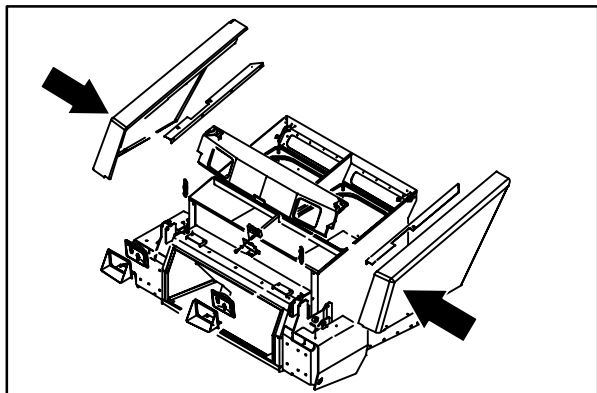
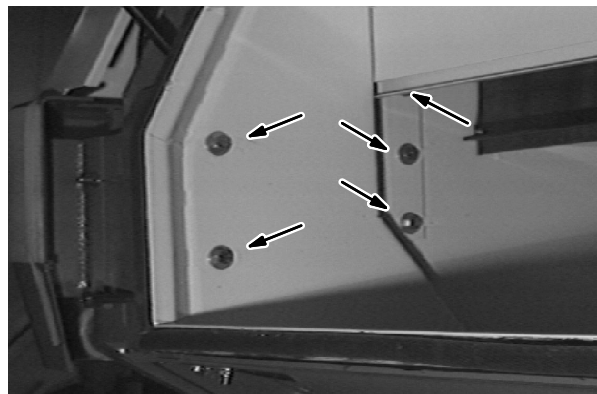
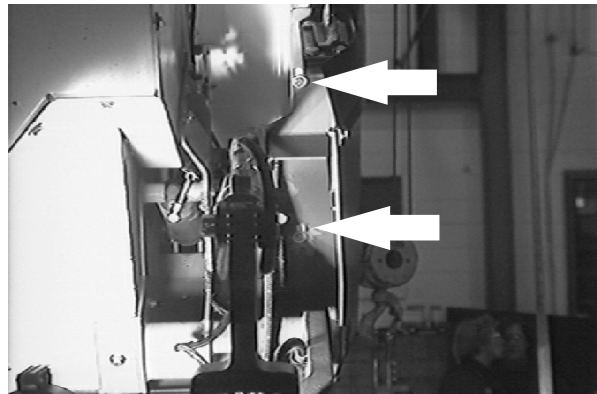

SWEEPING

10. Start the engine and roll the hopper slightly forward. Hook an over head hoist to the two adjustment bolts on the back of the hopper.
11. Remove the five M10 hex screws from on top of hopper in front.
12. Unbolt the bracket holding the hydraulic hose tee fittings at the front of the hopper.
13. Start the engine, close the dump door, and roll the hopper all the way out. Use the over head hoist to help roll the un-bolted hopper forward.
14. Unplug the hopper wire harness from the main harness. Remove any ties holding the harness to the lift arm.
15. The hopper can now be lifted up and out of the lift arms using the over head hoist.
16. Set the hopper on the floor.

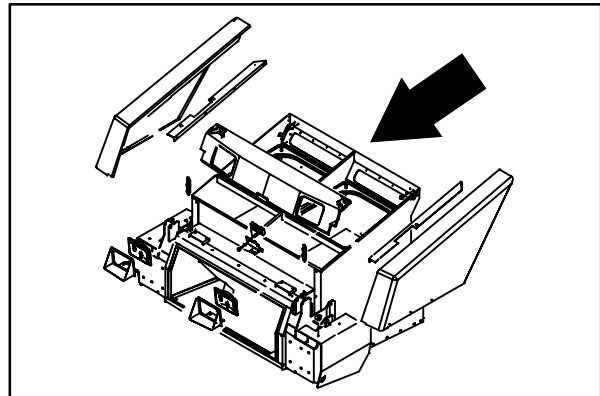
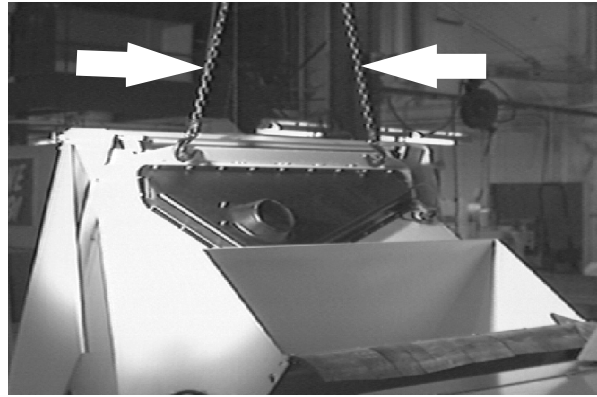

TO INSTALL HOPPER

1. Engage parking brake, Lift the hopper back into the machine using the rear adjustment bolts and a chain or strap.
2. Roll the hopper back half way. Open the hopper dump door.

FOR SAFETY: Before Leaving Or Servicing Machine; Stop On Level Surface, Set Parking Brake, Turn Off Machine And Remove Key.

3. Reinstall all the hopper hardware. Align holes by rocking hopper and using a drift punch.
4. Tighten the M10 hex screws to 37 - 48 Nm (27 - 35 ft lb).
5. Reinstall the hydraulic hose tee bracket. Tighten the M8 hex screws to 18 - 24 Nm (13 - 18 ft lb).
6. Reinstall the front headlight panel and RH and LH fenders. Tighten the ten M8 hex screws to 18 - 24 Nm (13 - 18 ft lb).
7. Reconnect the hopper harness to the main harness. Reattach the harness to the lift arms.
8. Close the hopper dump door, roll the hopper back, raise the hopper, engage the prop arm.
9. Reinstall the four M8 hex screws in the bottom of both fenders. Tighten to 18 - 24 Nm (13 - 18 ft lb).
10. Disengage the prop arm and lower the hopper.

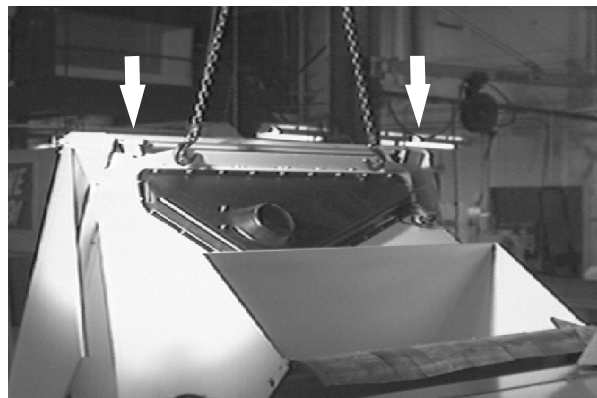
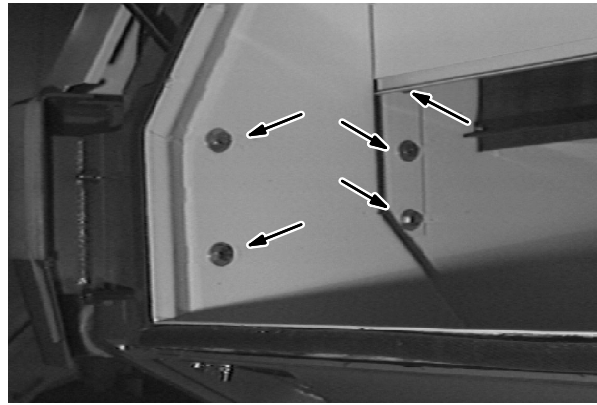
**TO ADJUST AND LEVEL HOPPER HEIGHT**

1. The two M12 hex screws at the rear of hopper should be set at 45 mm (1.75 in) from the head of bolt to the edge of bracket.

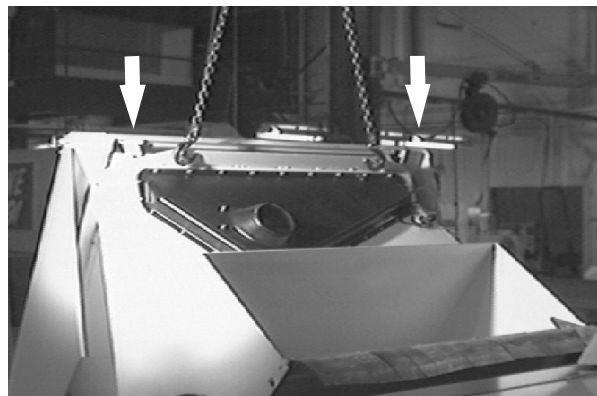

SWEEPING

HOPPER DUMP DOOR

The hopper dump door is used to control the hopper debris when dumping.

TO REMOVE HOPPER DUMP DOOR

FOR SAFETY: Before Leaving Or Servicing Machine; Stop On Level Surface, Set Parking Brake, Turn Off Machine And Remove Key.

1. Make sure the hopper has been emptied of all debris.
2. Set the parking brake, Raise the hopper and engage the prop arm.

⚠ WARNING: Raised Hopper May Fall. Engage Hopper Support Bar.

3. Remove the two M8 hex screws holding each fender to the hopper bumper. Disengage the prop arm and lower the hopper.
4. Open hopper cover and remove eight M8 hex screws attaching LH and RH fenders to hopper.
5. Open the front headlight panel. Spread the front fenders apart and pull the headlight panel out of the hole on each end.
6. Remove the headlight panel and both front fenders from the machine.
7. Start the machine and open hopper dump door.
8. Brace the dump door up with jack stands.
9. Remove the cotter keys from pins at the rod end of the dump door cylinders.
10. Slide the clevis pins out of each cylinder and door. *Make sure dump door is supported before removing the pins.*
11. Loosen the set screws on both centering sleeves on upper hopper door pins.
12. Remove the M12 hex screws and nyloc nuts.
13. The hopper door can now be removed from the machine.

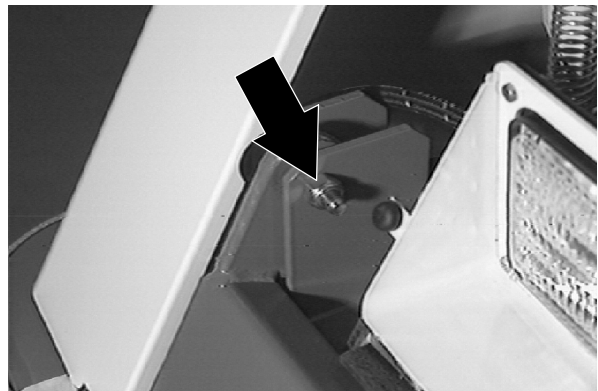
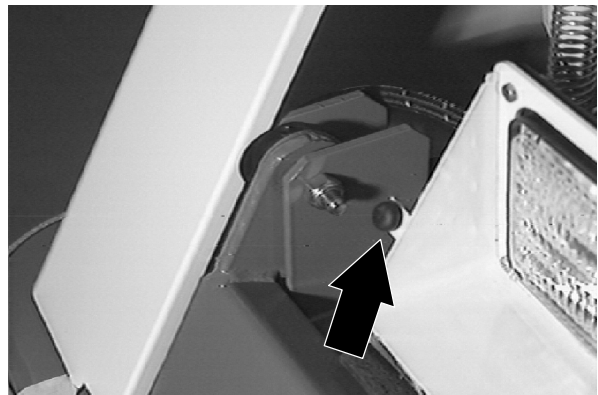
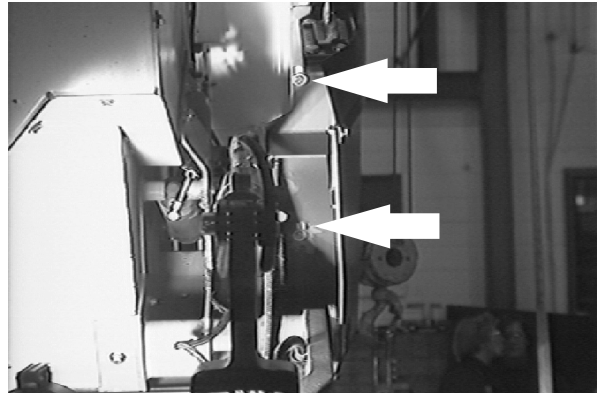
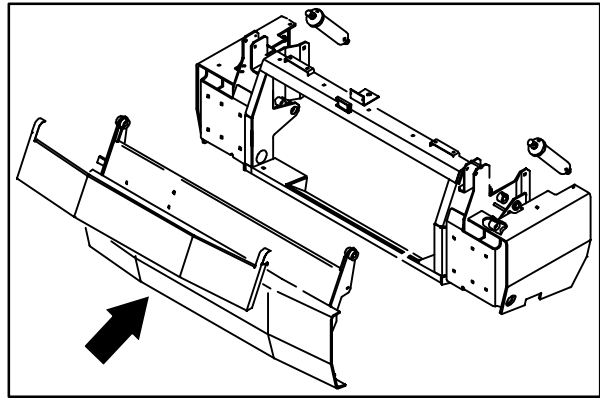

TO INSTALL HOPPER DUMP DOOR

FOR SAFETY: Before Leaving Or Servicing Machine; Stop On Level Surface, Set Parking Brake, Turn Off Machine And Remove Key.

1. Position the dump door in front of the machine with the pivot ears pointing up.
2. Align the upper bearing sleeves with the holes in bumper ears. Install the M12 hex screws and nyloc nuts. Tighten to 64 - 83 Nm (47 - 60 ft lb).
3. Center the dump door and tighten the set screws on the centering sleeves.
4. Align the holes in rod end of the dump door cylinder with the holes in dump door. Slide the clevis pin through the hole and install the washer and cotter key.
5. Start the machine and close the dump door.
6. Reinstall the headlight panel, RH and LH fenders. Tighten the ten M8 hex screws to 18 - 24 Nm (13 - 18 ft lb).
7. Reconnect the hopper harness to the main harness. Reattach the harness to the lift arms.
8. Close the hopper dump door, roll the hopper back, raise the hopper, engage the prop arm.
9. Reinstall the four M8 hex screws in the bottom of both fenders. Tighten to 18 - 24 Nm (13 - 18 ft lb).
10. Disengage the prop arm and lower the hopper.

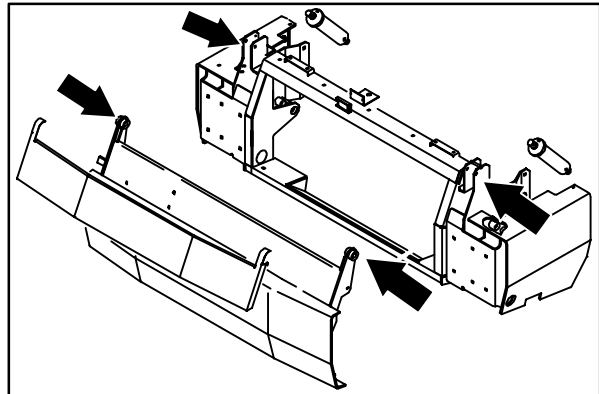
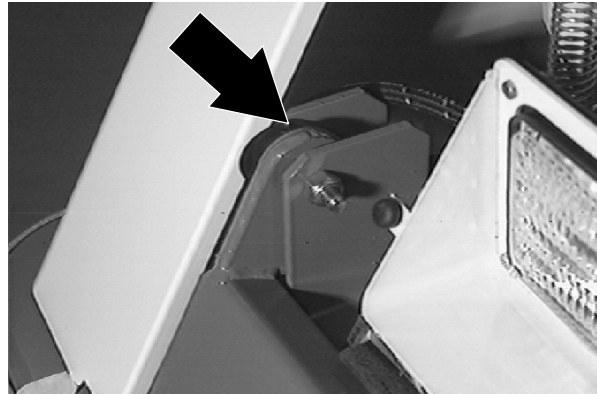
**TO ADJUST HOPPER DUMP DOOR**

FOR SAFETY: Before Leaving Or Servicing Machine; Stop On Level Surface, Set Parking Brake, Turn Off Machine And Remove Key.

1. Engage the parking brake and open the hopper dump door.
2. Use the two 0.50 in x 3.5 in hex screws located in the lower corner of front bumper to adjust hopper dump door in and out for proper seal.

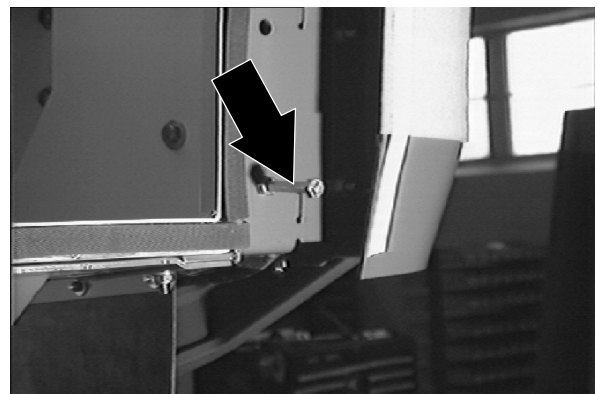

HOPPER DUST FILTER

The dust filters filter the air pulled up from the hopper. The dust filters are equipped with a shaker to remove the accumulated dust particles. The dust filters shaker is operated by the filter shaker switch.

Shake the dust filters before dumping the hopper and at the end of every work shift. Check and clean the dust filters every 50 hours of operation. Extremely dusty conditions may require more frequent cleaning of dust filters.

To clean the dust filters, use one of the following methods:

- SHAKING - Press the filter shaker switch.
- AIR - Blow compressed air through the dust filter from the inside. This may be done with the dust filter in the machine, or for more efficient cleaning remove the dust filter from the machine and the prescreen wrap from the filter element. Always wear eye protection when using compressed air.

FOR SAFETY: When Servicing Machine, Wear Eye And Ear Protection When Using Pressurized Air Or Water.

- WATER - Remove the fabric prescreen wrap from the filter element. Wash the prescreen wrap in a water and mild detergent solution. Rinse the prescreen wrap until it is clean. Air dry the wet prescreen wrap; do not use compressed air. **NEVER** wash the filter element with water.

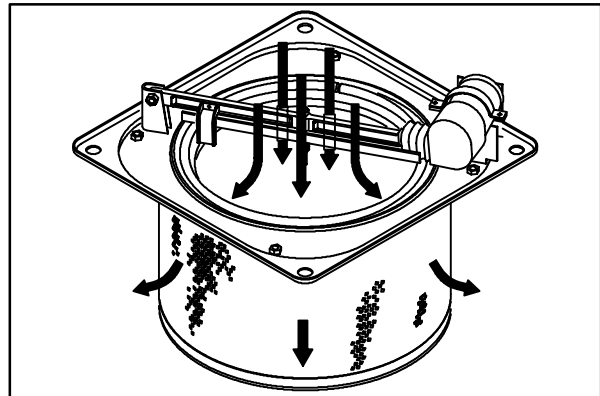

TO REMOVE OR REPLACE HOPPER DUST FILTER

1. Stop the engine and set the machine parking brake.

FOR SAFETY: Before Leaving Or Servicing Machine; Stop On Level Surface, Set Parking Brake, Turn Off Machine And Remove Key.

2. Open the hopper cover.
3. Disconnect the shaker motor wire connectors.

4. Remove the four retaining screws from the filter shaker frame.
5. Pull the filter shaker frame out of the hopper.
6. To ease in the removal of the shaker frame the hopper should be rolled forward slightly.
7. Carefully turn over the shaker frame and element.
8. Remove the four filter retaining screws from the shaker frame.
9. Remove the retainer ring from the shaker frame. Remove the filter.

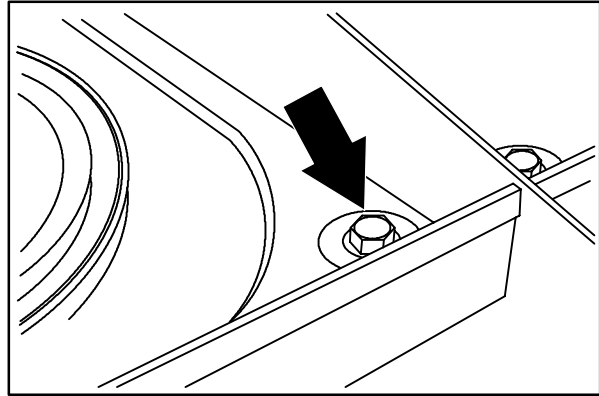

08591

NOTE: At this point inspect the shaker assembly for worn pivot bearings or torn dust seal. Repair or replace as necessary. Also lubricate the eccentric roller bearings.

10. Make sure the prescreen wrap is tightly wrapped around and securely fastened on the new filter element. Put the new filter on the filter shaker frame.
11. Place the retainer ring over the filter. Make sure the retaining ring fits inside the lip of the filter element all the way around. Line up the slots on the retainer ring with the retaining screws holes.

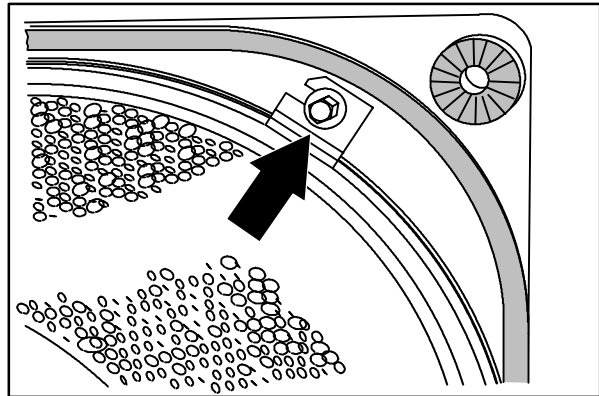

08592

12. Mount using the retaining screws.
13. Check the seal on the shaker frame for damage. Make sure the vibration isolators are mounted in all four corners of the filter shaker frame.
14. Put the filter and shaker frame in the hopper.
15. Install the four retaining screws and tighten.
16. Connect the shaker motor wire connectors.
17. Check the shaker ring to filter clearance. Make sure the cam is in the lowest position. There should be 0.125 in clearance around the entire shaker ring. Use three 0.125 in drill bits as gauges. The shaker ring is adjusted with the two jam nuts on the shaker stem.

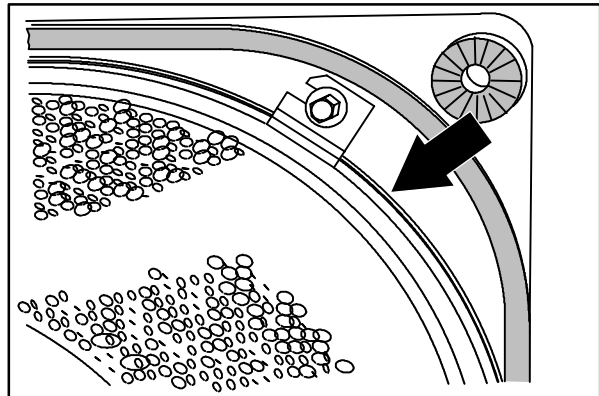

08593

NOTE: Make sure that the jam nuts are TIGHT when the adjustment is complete.

SWEEPING

THERMO SENTRY™

The Thermo Sentry™ senses the temperature of the air pulled up from the hopper. If there is a fire in the hopper, the Thermo Sentry™ stops the vacuum fan and cuts off the air flow. The Thermo Sentry™ is located on the vacuum fan housing.

Reset the Thermo Sentry™ by pushing in its reset button.

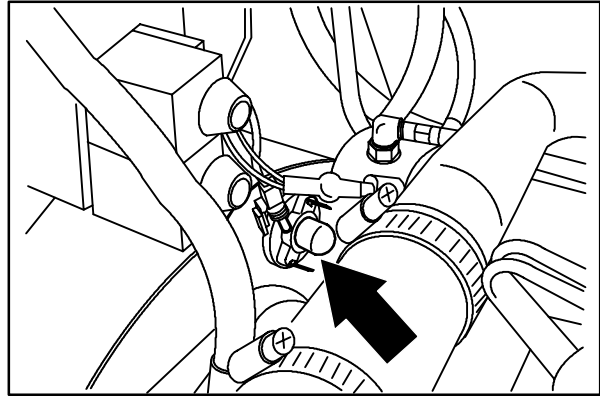

08928

TO REPLACE THERMO SENTRY™

FOR SAFETY: Before Leaving Or Servicing Machine; Stop On Level Surface, Set Parking Brake, Turn Off Machine And Remove Key.

1. Open engine cover and side door.
2. Disconnect Thermo Sentry™ from wire harness.
3. Remove the two bolts holding the Thermo Sentry™ to the vacuum fan housing.
4. Mount new Thermo Sentry™ with existing hardware.
5. Connect the wires back to the Thermo Sentry™.
6. Close engine cover and side door.

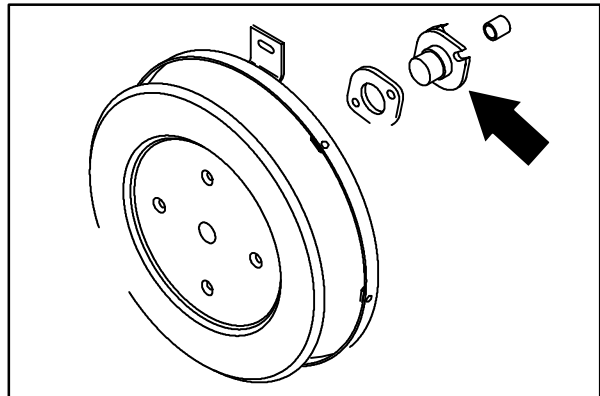

BRUSHES

MAIN BRUSH

The main brush is cylindrical and spans the width of the machine, sweeping debris into the hopper.

Check the brush daily for wear or damage. Remove any string or wire tangled on the main brush, main brush drive hub, or main brush idler hub.

Check the main brush pattern daily. The pattern should be 50 to 65 mm (2 to 2.5 in) wide. Adjust the main brush pattern by turning the main brush pressure knob located next to the operator seat.

Rotate the main brush end-for-end every 50 hours of operation for maximum brush life and best sweeping performance.

Replace the main brush when the remaining bristles measure 30 mm (1.25 in) in length.

TO REPLACE MAIN BRUSH

1. Raise the main brush.
2. Stop the engine and set the machine parking brake.

FOR SAFETY: Before Leaving Or Servicing Machine; Stop On Level Surface, Set Parking Brake, Turn Off Machine And Remove Key.

3. Open the right side main brush access door.
4. Unlatch and remove the brush idler plate.
5. Grasp the main brush; pull it off the brush drive plug and out of the main brush compartment.
6. Put the new or rotated end-for-end main brush on the floor next to the access door.
7. Slide the main brush onto the drive plug. Rotate the brush until it engages the drive plug, and push it all the way onto the plug.
8. Slide the main brush idler plate plug into the main brush.
9. Latch the idler plate on the machine frame.
10. Close the right side main brush access door.

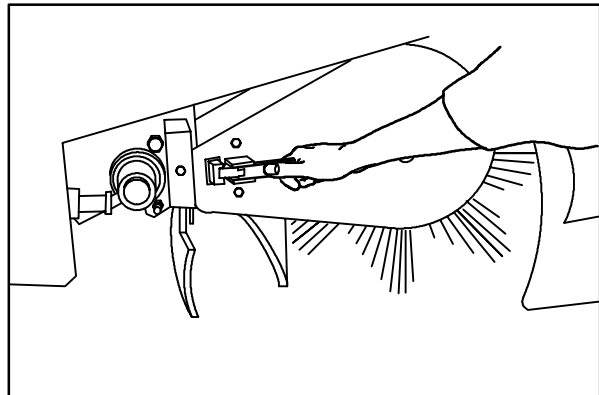

08487

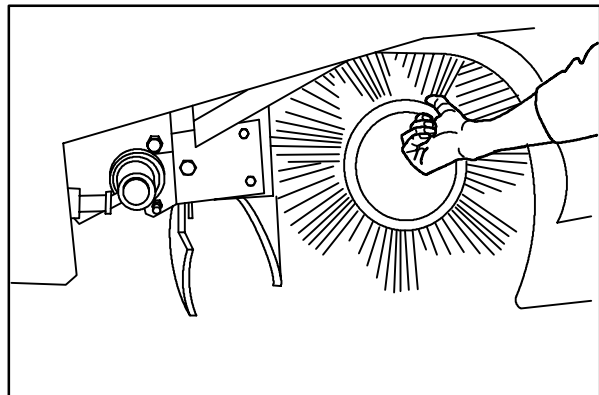

08488

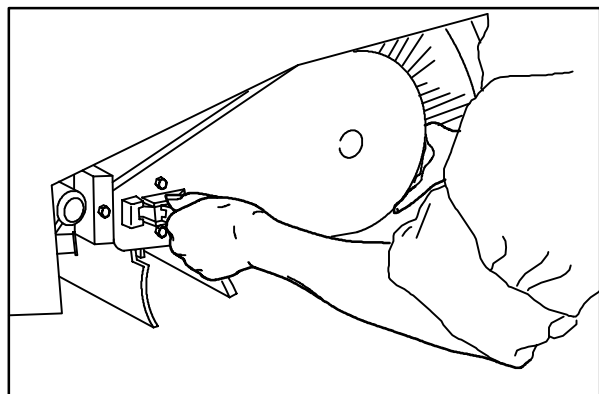

08489

SWEEPING

TO CHECK AND ADJUST MAIN BRUSH PATTERN

1. Apply chalk, or some other material that will not blow away easily, to a smooth, level floor.
2. Raise the side brush and main brush and position the main brush over the chalked area.
3. Start the main brush.
4. Lower the main brush for 15 to 20 seconds while keeping a foot on the brakes to keep the machine from moving. This will lower the rotating main brush.

NOTE: If chalk or other material is not available, allow the brushes to spin on the floor for two minutes. A polish mark will remain on the floor.

5. Raise the main brush.
6. Stop the main brush.
7. Drive the machine off the test area.
8. Observe the width of the brush pattern. The proper brush pattern width is 65 to 75 mm (2.5 to 3.5 in).

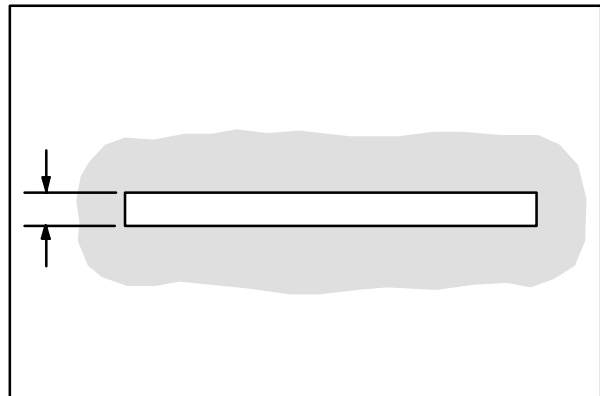

00582

9. To increase the width of the main brush pattern, turn the main brush down pressure knob counter-clockwise,  **Heavy**.

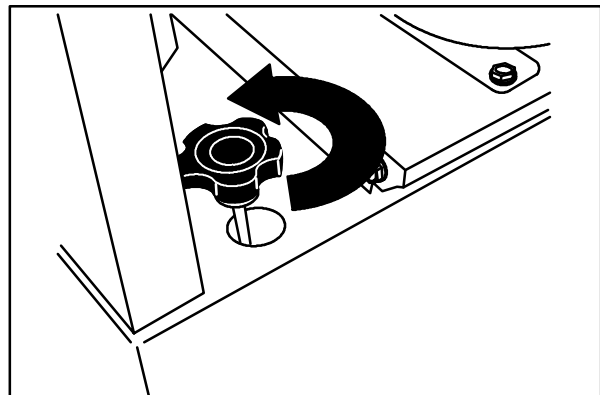

08442

10. To decrease the width of the main brush pattern, turn the main brush down pressure knob clockwise  **Light**.

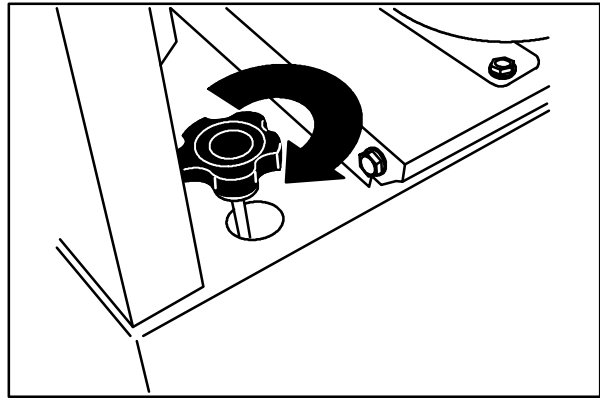

08441

11. If the main brush pattern is tapered, more than 15 mm (0.5 in) on one end than the other, adjust the taper at the drive end of the brush.

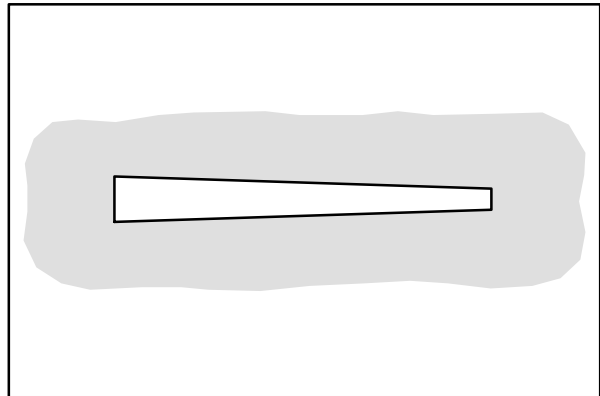

00601

- A. Loosen the brush drive end plate mounting bolts.
- B. Turn the taper adjustment nut counter-clockwise to increase the pattern width at the brush drive end, and clockwise to decrease the pattern width at the brush drive end. Tighten the drive end plate mounting bolts.
- C. Check the main brush pattern and readjust as necessary. Then adjust the width of the main brush pattern.

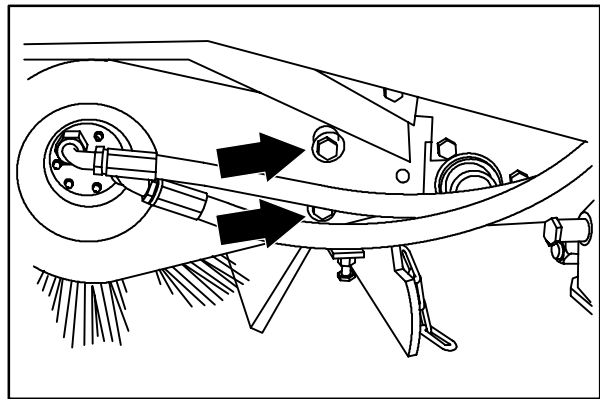

08450

12. For maximum brush life always use the minimum pattern to get good pickup. If the brush is adjusted to a large pattern for an uneven surface or a depression, it should be returned to the lighter pattern as soon as possible.

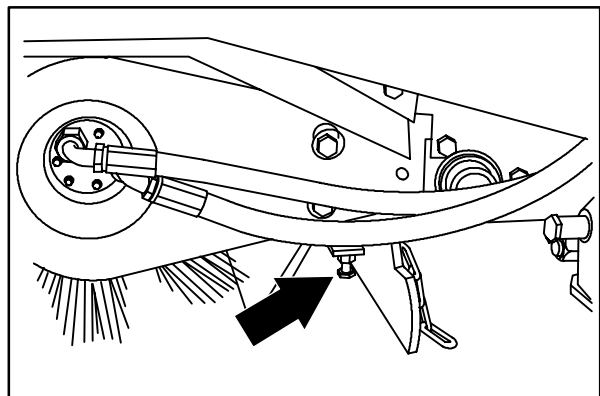

08490

SWEEPING

TO REPLACE MAIN BRUSH IDLER PLUG BEARING

FOR SAFETY: Before Leaving Or Servicing Machine; Stop On Level Surface, Set Parking Brake, Turn Off Machine And Remove Key.

1. Remove the main brush idler arm from the machine. See TO REPLACE MAIN BRUSH instructions in this section.
2. Remove the plastic cap from the idler plug.
3. Clean the area around where the cap was mounted to the idler plug.
4. Remove the M12 hex screw, nyloc hex nut, and washer holding the idler plug to the idler arm. Save the hardware.
5. Remove the four M6 hex screws holding the idler shaft in the idler plug. Remove the shaft and cover. Save the hardware.
6. Remove the bearing seal plate, retainer and bearing.
7. Clean the inside of the idler plug.
8. Place a new bearing, the seal plate and the retainer in the idler.
9. Thread the four screws and flat washers into place.
10. Install the idler shaft and tighten the four bolts to 8 - 10 Nm (6 - 8 ft lb).
11. Slide the idler plug on the idler arm shaft. Secure it with the hardware removed earlier. Tighten hardware to 68 - 81 Nm (50 - 60 ft lb).
12. Apply RTV to contact area where plastic cap will fit one end of idle plug. Snap plastic cap into place.

Note: If you replace idler arm latch, use blue loctite on hardware to hold in place.

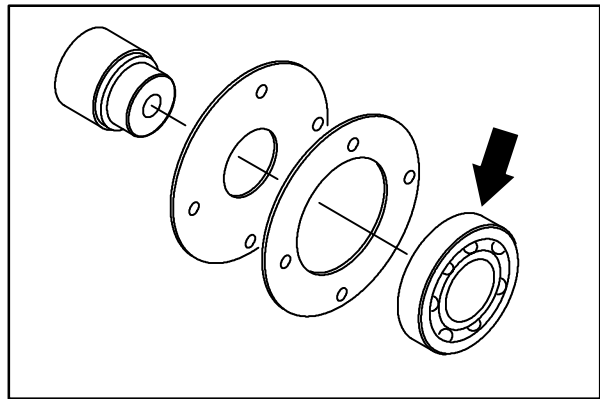
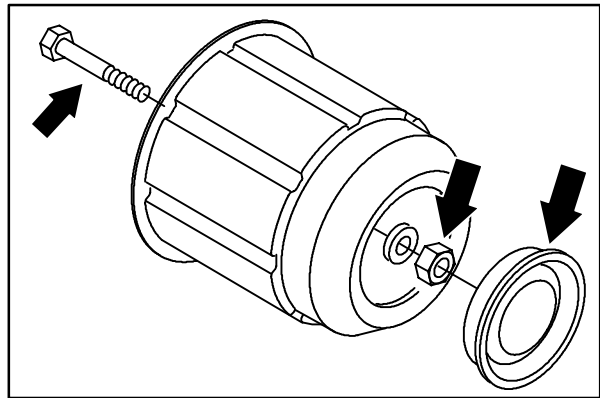
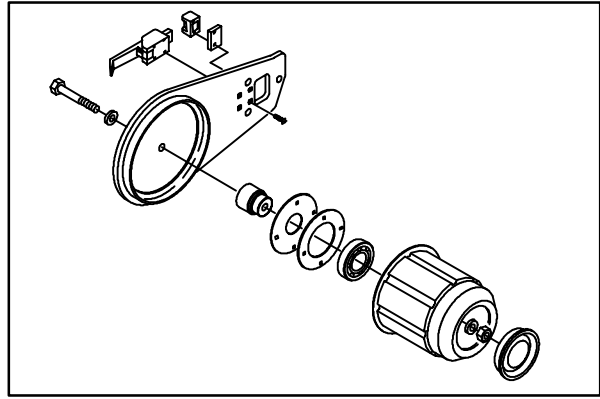

TO REPLACE MAIN BRUSH SHAFT BEARINGS

FOR SAFETY: Before Leaving Or Servicing Machine; Stop On Level Surface, Set Parking Brake, Turn Off Machine And Remove Key.

1. Remove the main brush. See TO REPLACE MAIN BRUSH instructions in this section.
2. Remove the two M12 hex screws holding main brush motor arm to brush shaft. Place arm to the side without disconnecting hydraulic hoses.
3. Remove the brush lift cable clevis from the brush shaft arm.
4. Remove two M10 hex screws holding bearing flange to main frame. Do this on both sides.
5. Drop main brush shaft out of machine.
6. Secure brush shaft in vice.
7. Remove M8 hex screw holding brush pattern adjustment tab on idler side of brush shaft. Remove tab.
8. Remove the remaining hex screw in three hole bearing flange.
9. Loosen the bearing set screws and slide the bearings off the shaft.
10. Slide the new bearings on the shaft with the collar facing the ends of the shaft end. Be sure to have a bearing flange on each side of each bearing. Leave collars loose.
11. Reinstall one hex screw into bearing flange on each side. Tighten to 18 - 24 Nm (13 - 18 ft lb).
12. Reinstall the brush shaft in the machine.

NOTE: Make sure bearing flanges are on the inside of main frame.

13. Align two remaining holes in bearing flanges with holes in main frame. Install M10 hex screws and tighten to 37 - 48 Nm (26 - 34 ft lb).

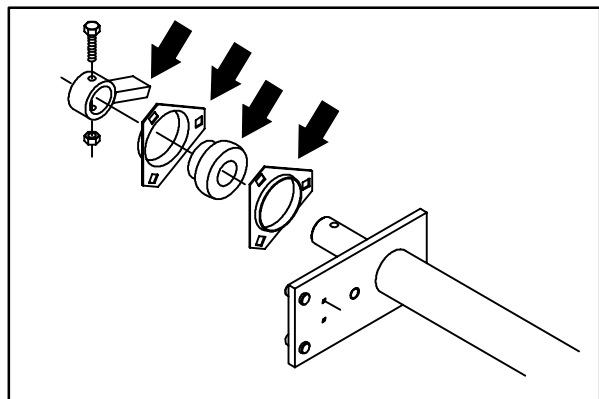
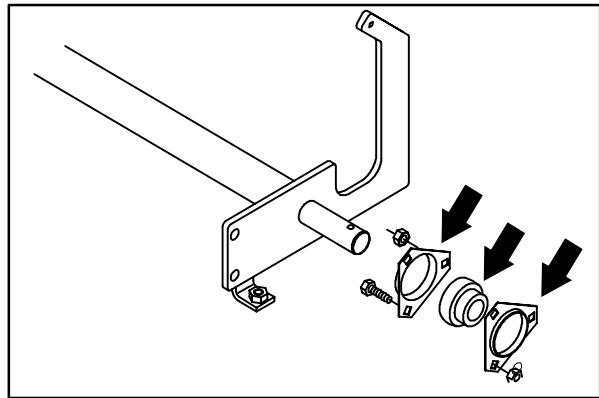
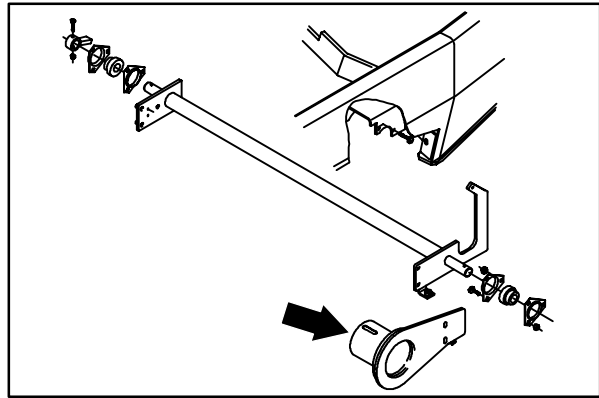

SWEEPING

14. Center brush shaft in machine. Tighten bearing collars by turning on shaft. Hand tighten set screws.
15. Reinstall main brush lift cable clevis pin.
16. Reinstall main brush motor arm using M12 hex screws. Tighten to 64 - 83 Nm (47 - 61 ft lb).
17. Reinstall brush pattern adjustment tab using M8 hex screw. Tighten to 18 - 24 Nm (13 - 18 ft lb).
18. Reinstall main brush and check pattern. Adjust if necessary.

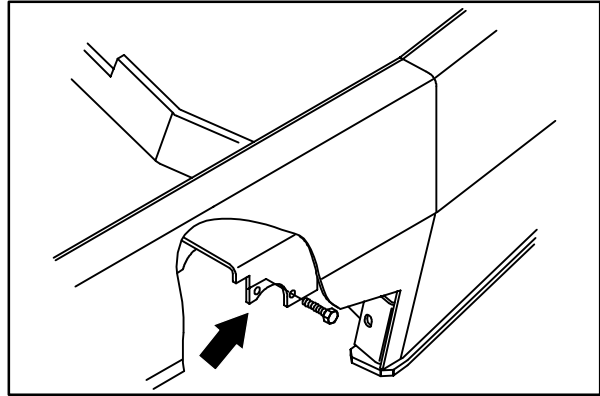

Note: If you are replacing the idler arm latch bracket, use blue locktite to hold the bolts in place. Tighten the bolts to 8 - 10 Nm (6 - 8 ft lb).

POWER THROW™

The Power Throw™ loads the hopper with debris picked up by the main brush.

Check the brush daily for wear or damage. Remove any string or wire tangled on the main brush, main brush drive hub, or main brush idler hub.

The Power Throw™ brush should clear the floor by 7 to 13 mm (0.25 to 0.50 in). Adjust the floor clearance with the adjusting bolt located under the seat on the Power Throw™ cross-tube. Turn the bolt clockwise to increase the floor clearance, and counter-clockwise to decrease the floor clearance.

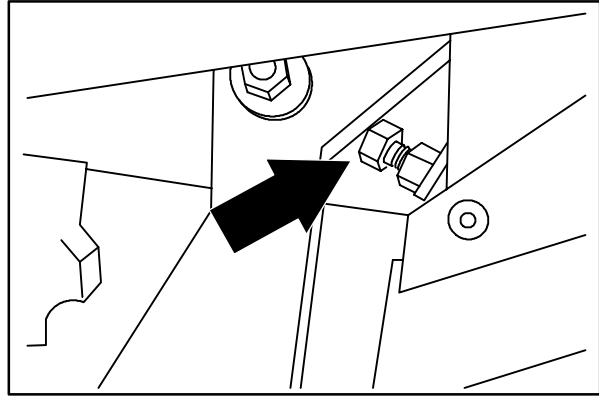

08583

TO REPLACE POWER THROW™ BRUSH

1. Set the machine parking brake and open the right main brush door.
2. Raise the hopper and secure with the hopper prop arm.

⚠ WARNING: Raised Hopper May Fall. Engage Hopper Support Bar.

3. Lower the Power Throw™.
4. Shut off the engine.

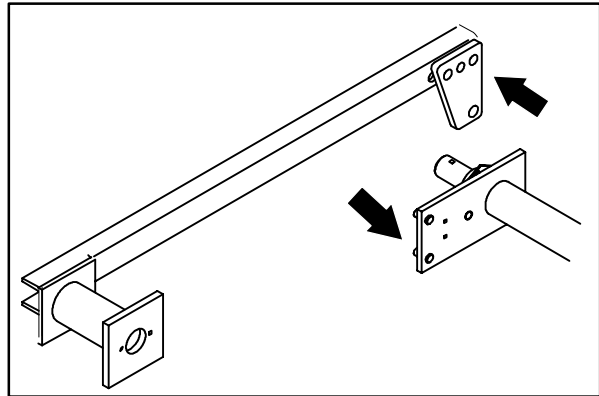

FOR SAFETY: Before Leaving Or Servicing Machine; Stop On Level Surface, Set Parking Brake, Turn Off Machine And Remove Key.

5. Remove the hex screw holding the idler plate of the Power Throw™ to the brush torque tube. Remove the brush idler plate.
6. Pull the Power Throw™ brush off the drive plug.
7. Slide the new brush on the drive end of the Power Throw™.
8. Slide the brush idler plate plug onto the brush.
9. Reinstall the brush idler plate and hex screw.
10. Lower the hopper and operate the machine, checking for proper operation.

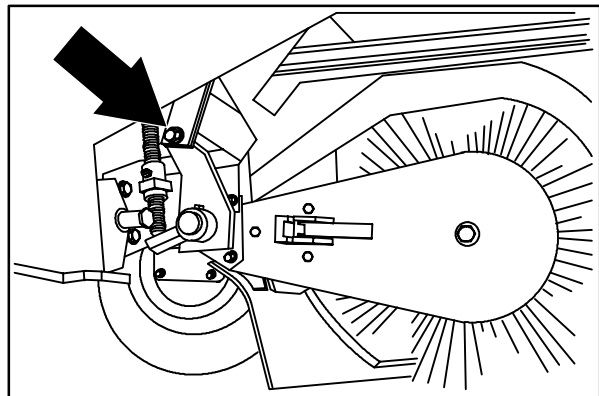

08584

SWEEPING

TO REPLACE POWER THROW™ BRUSH IDLER BEARINGS

FOR SAFETY: Before Leaving Or Servicing Machine; Stop On Level Surface, Set Parking Brake, Turn Off Machine And Remove Key.

1. Set the machine parking brake and remove the Power Throw™ brush and idler plate. See TO REPLACE POWER THROW™ BRUSH instructions in this section.

⚠ WARNING: Raised Hopper May Fall. Engage Hopper Support Bar.

2. Remove the M6 hex screw holding the plastic idler plug on the idler shaft. Pull the plug off the idler shaft. Retain the square key.
3. Remove the two M6 hex screws holding the bearing cup to the idler arm. Remove the bearing cup assembly.
4. Remove the first snap ring from the shaft.
5. Press the bearing nearest the key way off the shaft.
6. Press the second bearing off the shaft.
7. Press both the new bearings on the shaft. Be careful not to damage the snap rings when pressing the bearings on.
8. Reinstall the bearing cup assembly to brush arm using the two M6 hex screws. Tighten to 8 - 10 Nm (5 - 7 ft lb).
9. Reinstall the snap ring that was removed in step 4.
10. Reinstall the idler plug to shaft using M6 hex screw. Tighten to 8 - 10 Nm (5 - 7 ft lb).
11. Reinstall the idler plate back on the machine.
12. Reinstall the brush, lower the hopper, and operate the machine. Check for proper brush operation.

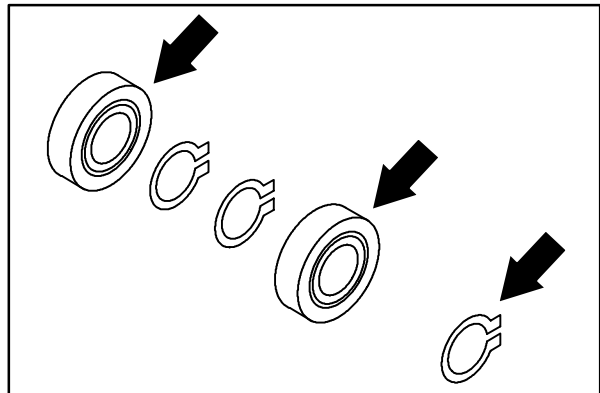
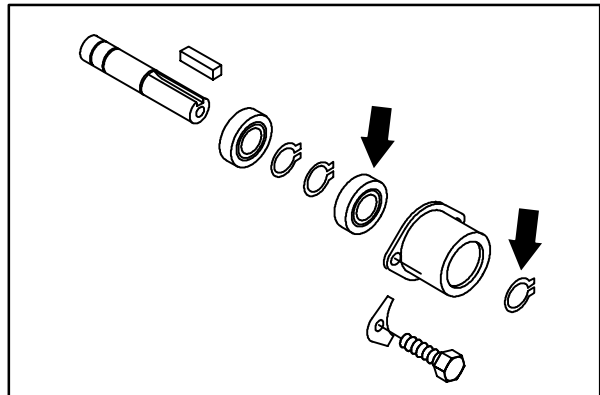
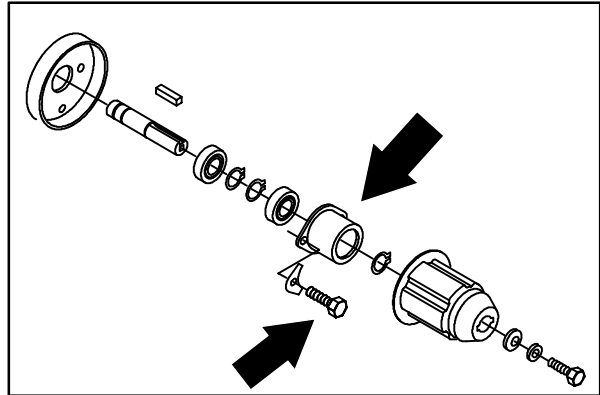
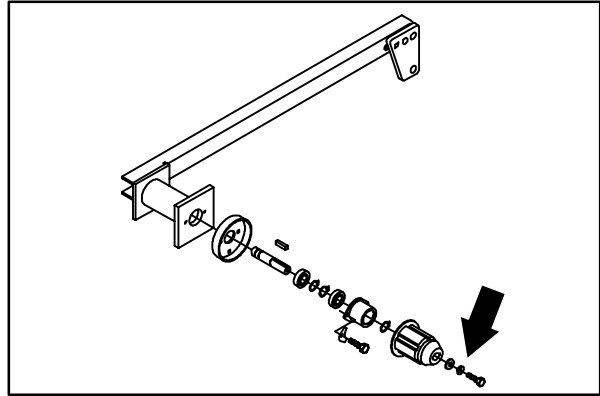

SIDE BRUSH

The side brush sweeps debris along edges into the path of the main brush.

Check the brush daily for wear or damage. Remove any string or wire found tangled on the side brush or side brush drive hub.

Check the side brush pattern daily. One-half of the side brush bristles should contact the floor when the brush is in motion. Adjust the side brush pattern by the side brush down pressure knob. Turn the knob counter-clockwise to increase the brush contact with the sweeping surface, and clockwise to decrease the brush contact with the sweeping surface.

The side brush should be replaced when it no longer sweeps effectively for your application. A guideline length is when the remaining bristles measure 50 mm (2 in) in length. You may change the side brush sooner if you are sweeping light litter, or wear the bristles shorter if you are sweeping heavy debris.

TO REPLACE SIDE BRUSH

1. Make sure the hopper has been emptied of all debris.
2. Set the parking brake, Raise the hopper and engage the prop arm.
3. Shut off the engine.

FOR SAFETY: Before Leaving Or Servicing Machine; Stop On Level Surface, Set Parking Brake, Turn Off Machine And Remove Key.

4. Pull the hair pin and cable out of the hole in the end of the side brush retaining clevis pin. Remove the clevis pin from the side brush hub.
5. Slide the side brush off the side brush drive shaft.
6. Remove the five hex screws holding the drive adaptor to the brush. Remove the drive adaptor and install it on the new brush.
7. Slide the new side brush on the side brush drive shaft.

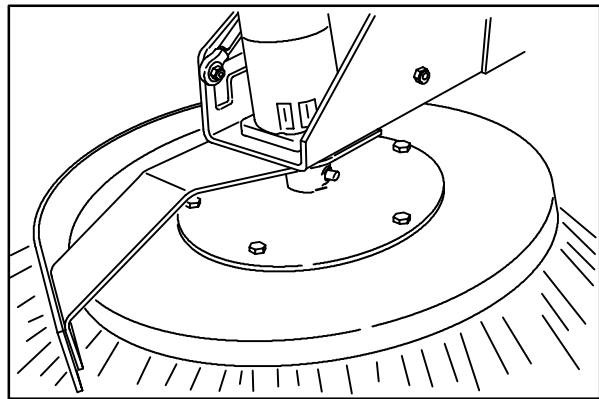

08466

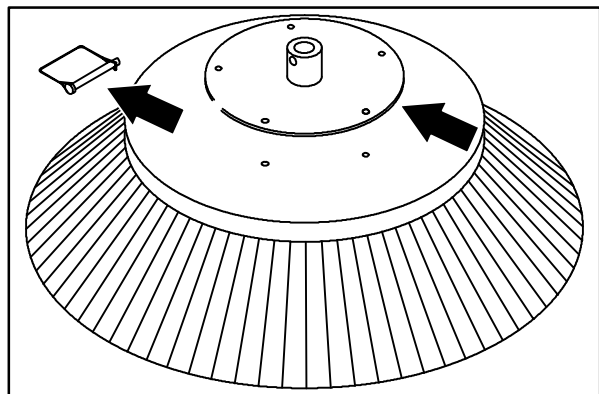

SWEEPING

8. Insert the side brush clevis pin through the side brush hub and shaft. Reinstall the hair pin and cable back into the hole in the end of the clevis pin.
9. Secure the pin by clipping the pin keeper over the end of the pin.
10. Disengage the hopper prop arm and lower the hopper.
11. Adjust the side brush pattern with the side brush down pressure knob.

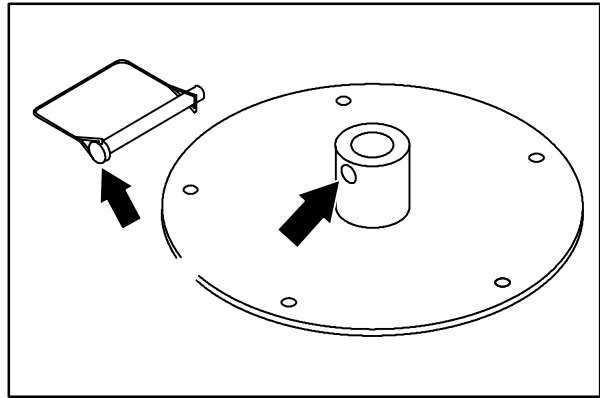

TO ADJUST SIDE BRUSH TIP ANGLE

1. Raise the hopper and engage the prop arm.

FOR SAFETY: Before Leaving Or Servicing Machine; Stop On Level Surface, Set Parking Brake, Turn Off Machine And Remove Key.

2. Remove the M10 hex screw holding the side brush lift cable to the lift arms.
3. Carefully lower side brush down onto the side brush lift stop.
4. Make sure the side brush is down in the sweep mode.
5. Locate the M10 threaded rod with two M10 jam nuts in the upper center of the side brush motor mount bracket.
6. Loosen the rear jam nut and tighten the front one. This will flatten out the brush pattern on a worn brush and help maintain proper sweeping performance.
7. Reconnect the side brush cable to the lift arms using the M10 hex screw and washer. Tighten to 52 - 67 Nm (39 - 51 ft lb).
8. Disengage prop arm, lower hopper and check side brush for proper operation.

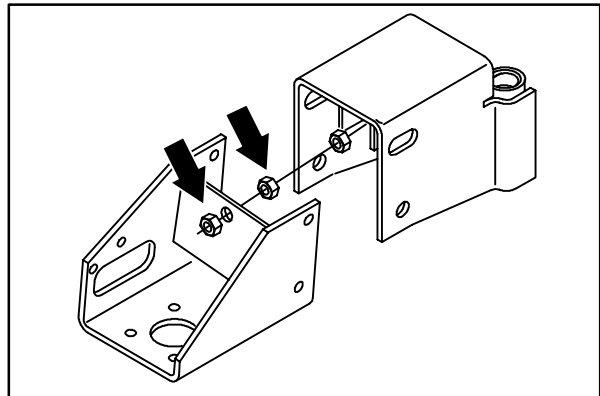
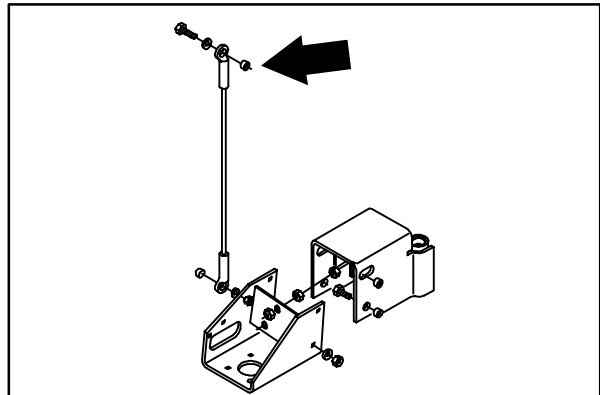

TO ADJUST SIDE BRUSH RIDE HEIGHT

1. Raise the hopper and engage prop arm.

FOR SAFETY: Before Leaving Or Servicing Machine; Stop On Level Surface, Set Parking Brake, Turn Off Machine And Remove Key.

2. Remove the M10 hex screw holding the side brush lift cable to the lift arms.
3. Carefully lower side brush down onto the side brush lift stop.
4. Make sure the side brush is down in the sweep mode.
5. Loosen the two M8 hex screws holding the side brush cable lift bracket to the side of the side brush motor mount bracket.
6. Adjust the side brush to the desired height of approximately 0.50 in from lower edge of bumper with the side brush in the raised position. Tighten the hex screws to 18 - 24 Nm (15 - 20 ft lb).
7. Reconnect the hopper up side brush cable to the lift arms. using the M10 hex screw and washer. Tighten to 52 - 67 Nm (39 - 51 ft lb).
8. Disengage prop arm, lower hopper and check side brush for proper operation.

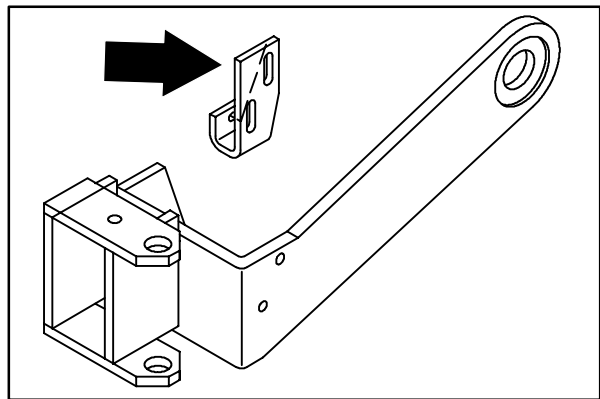
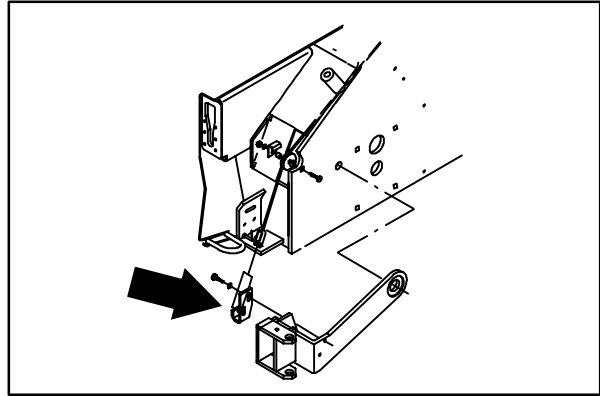

SWEEPING

SKIRTS AND SEALS

The hopper lip skirts are located on the bottom rear of the hopper. The skirts float over debris and help deflect that debris into the hopper. The top skirt is segmented.

Check the hopper lip skirts for wear or damage daily.

Replace the hopper lip skirts when they no longer touch the floor.

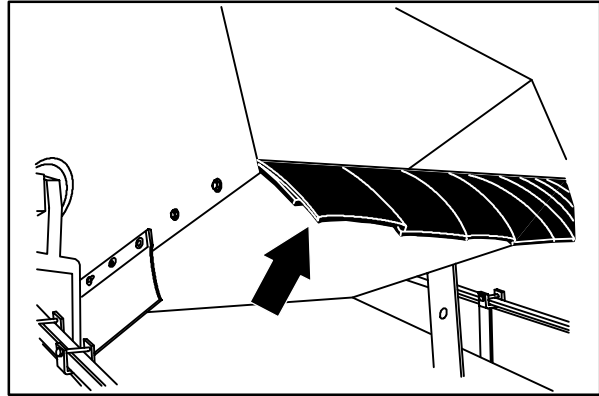

08491

TO REPLACE HOPPER LIP SKIRTS

1. Make sure the hopper has been emptied of all debris.
2. Set the parking brake, Raise the hopper and engage the prop arm.



**WARNING: Raised Hopper May Fall.
Engage Hopper Support Bar.**

3. Shut off the engine.

FOR SAFETY: Before Leaving Or Servicing Machine; Stop On Level Surface, Set Parking Brake, Turn Off Machine And Remove Key.

4. Remove the hopper lip retaining strip mounting bolts.
5. Remove the hopper lip retaining strip, the hopper lip, and the back-up strip.
6. Thread the retaining strip mounting bolts through the retaining strip, the new hopper lip, the back-up strip, and into the hopper.
7. Tighten the mounting bolts to 8 - 14 Nm (6 - 10 ft lb).
8. Start the engine.
9. Raise the hopper, disengage the hopper prop arm, and lower the hopper.
10. Operate the machine and check for proper operation.

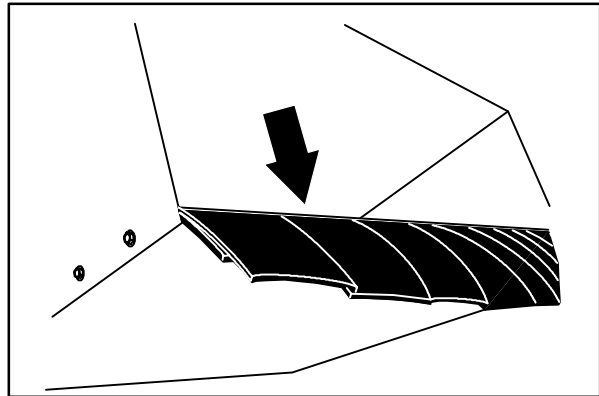

BRUSH COMPARTMENT SKIRTS

The brush compartment skirts are located on the bottom of each of the two main brush doors and around the ends of the brush on the main frame. The inside brush door skirt should touch the floor, and the outside brush door skirt should clear the floor by 5 mm (0.25 in).

Check the skirts for wear or damage and adjustment daily.

NOTE: The brush door skirts have slotted holes to allow for a ground clearance adjustment. The door must be closed for proper adjustment.

NOTE: Tire pressure will affect skirt clearances.

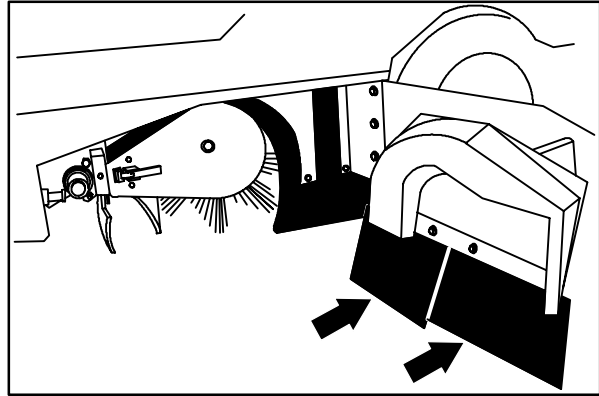

TO REPLACE AND ADJUST BRUSH DOOR SKIRTS

1. Park the machine on a smooth, level surface.
2. Stop the engine and set the machine parking brake.

FOR SAFETY: Before Leaving Or Servicing Machine; Stop On Level Surface, Set Parking Brake, Turn Off Machine And Remove Key.

3. Open the main brush doors.
4. Remove the four hex screws holding the brush door skirts and retainer to the brush door.
5. Remove the skirt retaining strip and both door skirts.
6. Discard the worn or damaged skirts.
7. Reinstall new skirts, skirt retainer, and M8 hex screws. Snug hex screws only at this time.
8. Close the brush door and adjust skirt to desired height 5 mm (0.25 in) off the floor.
9. Open the brush door and tighten M8 hex screws to 8 - 14 Nm (6 - 10 ft lb)
10. Repeat this on the other brush door.

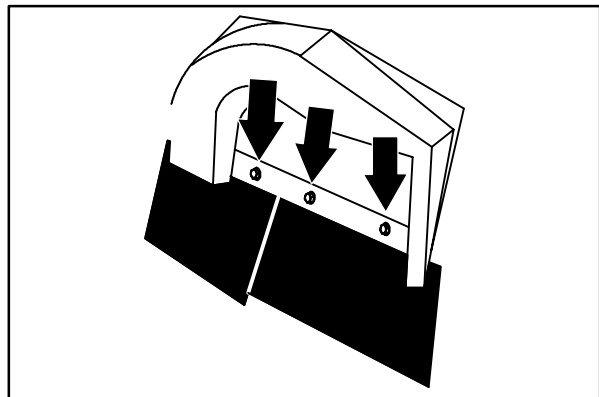

SWEEPING

REAR SKIRTS

The two rear skirts are located on the bottom rear of the main brush compartment. The vertical skirt should clear the floor up to 19 mm (0.75 in). The recirculation skirt is self-adjusting.

Check the skirts for wear or damage and adjustment daily.

NOTE: Tire pressure will affect skirt clearances.

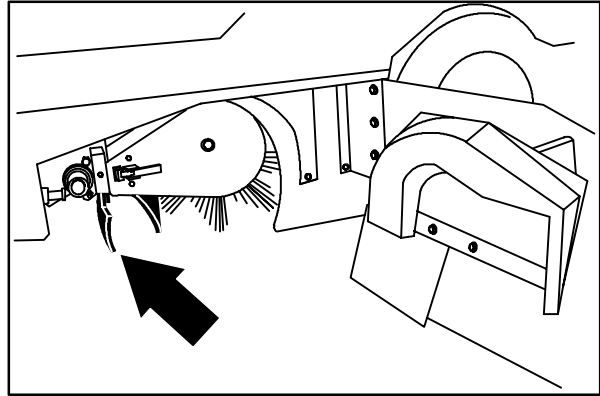

TO REPLACE AND ADJUST THE REAR SKIRT

1. Park the machine on a smooth, level surface.
2. Stop the engine and set the machine parking brake.

FOR SAFETY: Before Leaving Or Servicing Machine; Stop On Level Surface, Set Parking Brake, Turn Off Machine And Remove Key.

3. Open the main brush doors.
4. Remove the main brush. See TO REPLACE MAIN BRUSH instructions in this section.
5. Remove the five M8 hex screws and nyloc nuts holding the skirt retainer channel to the machine. Remove the skirt and retainer from the machine.
6. Discard the old skirt. Position the new skirt in place on the machine frame.
7. Thread the five hex screws through the retaining channel, the rear skirt, and the machine frame. Reuse the five nyloc nuts. Leave loose for now.

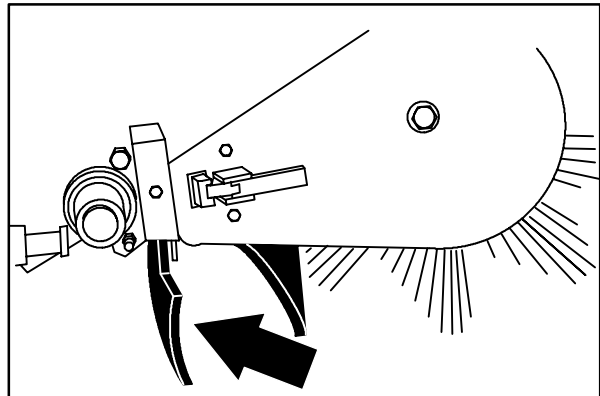

NOTE: Make sure to reinstall the static chain on the right hand skirt mounting hardware.

8. Slide the rear floor skirt up or down so that the skirt clears the floor by 19 mm (0.75 in).
9. Tighten the rear floor skirt mounting bolts to 8 - 14 Nm (6 - 10 ft lb).
10. Reinstall the main brush. See TO REPLACE MAIN BRUSH instructions in this section.
11. Close the brush doors and operate the machine. Check for proper rear skirt operation.

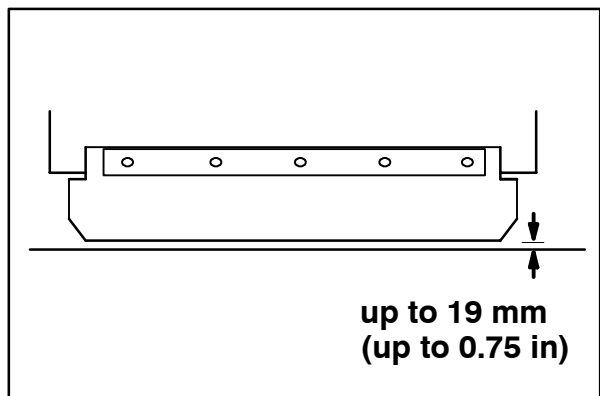
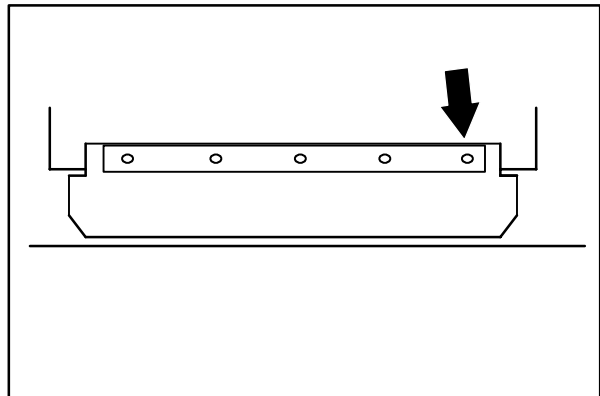

TO REPLACE AND ADJUST THE REAR DEFLECTOR SKIRT

1. Park the machine on a smooth, level surface.
2. Stop the engine and set the machine parking brake.

FOR SAFETY: Before Leaving Or Servicing Machine; Stop On Level Surface, Set Parking Brake, Turn Off Machine And Remove Key.

3. Open the main brush doors.
4. Remove the main brush. See TO REPLACE MAIN BRUSH instructions in this section.
5. Remove the four M8 hex screws and nyloc nuts holding the deflector skirt retainer strap to the deflector plate on the machine. Remove the skirt and retainer from the machine.
6. Discard the old skirt. Position the new deflector skirt and old retainer strap in place on the deflector plate on the machine.
7. Thread the four hex screws through the retaining strap, the deflector skirt, and the deflector plate. Reuse the four nyloc nuts. Leave loose for now.
8. Adjust the recirculation flap high enough in the slots so it can pivot back freely without hitting the floor.
9. Tighten the brush deflector blade mounting bolts to 8 - 14 Nm (6 - 10 ft lb).
10. Make sure the deflector spring moves the recirculation flap freely into position.
11. Make sure to clear any build up of dirt or debris from between the recirculation flap mounting bracket and the brush wrap frame.
12. After a period of time the recirculation flap will tend to curl down. When this happens remove it, turn it end for end and upside down, and reinstall. This will help maintain proper sweeping performance.
13. Reinstall the main brush. See TO REPLACE MAIN BRUSH instructions in this section.
14. Close the brush doors and operate the machine. Check for proper deflector skirt operation.

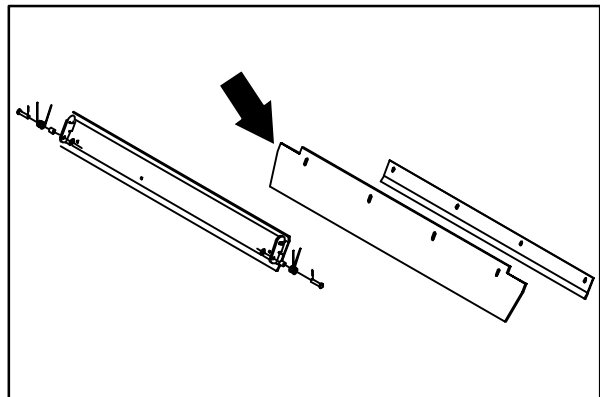
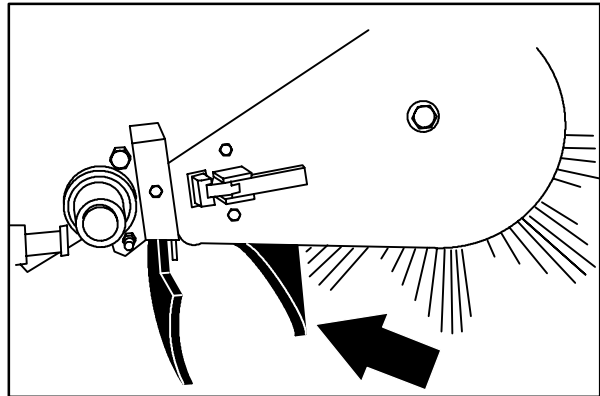
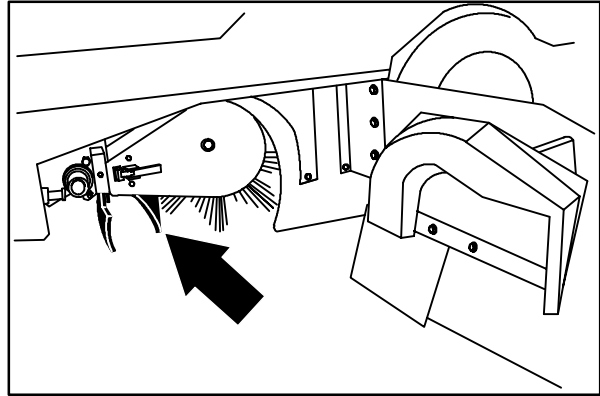

SWEEPING

BRUSH DOOR SEALS

The brush door seals are located on both main brush doors and on corresponding portions of the main frame.

Check the seals for wear or damage every 100 hours of operation.

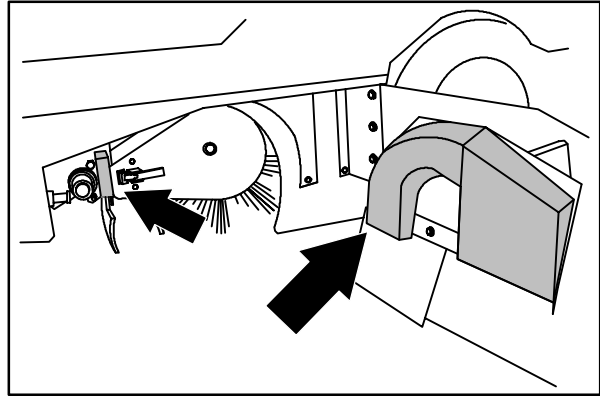

08495

HOPPER SEALS

The hopper seals are located on the top and side portions of the machine frame that contact the hopper.

Check the seals for wear or damage every 100 hours of operation.

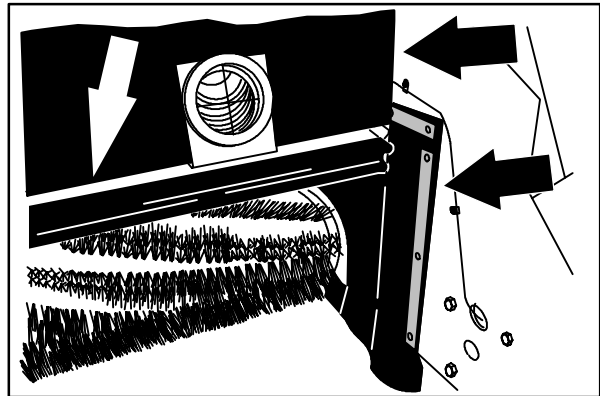

08496

TO REPLACE HOPPER WHEEL POCKET SEALS

1. Park the machine on a smooth, level surface.
2. Stop the engine and set the machine parking brake.

FOR SAFETY: Before Leaving Or Servicing Machine; Stop On Level Surface, Set Parking Brake, Turn Off Machine And Remove Key.

3. Raise hopper and engage hopper prop arm.

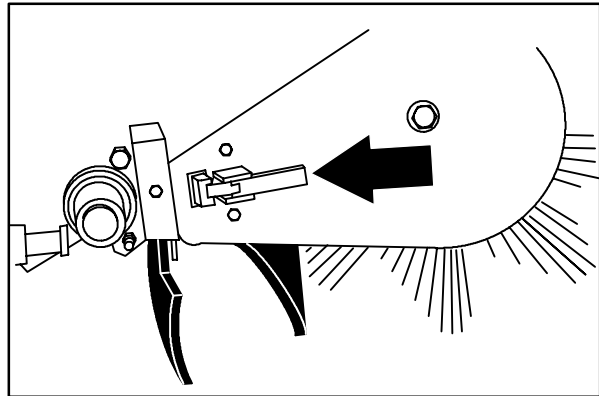

⚠ WARNING: Raised Hopper May Fall. Engage Hopper Support Bar.

4. Remove main brush. See TO REPLACE MAIN BRUSH instructions in this section.
5. Remove six M6 hex screws and five plastic rivets holding the four retainers and brush compartment seal to the machine frame.
6. Remove and discard the old brush compartment seal.

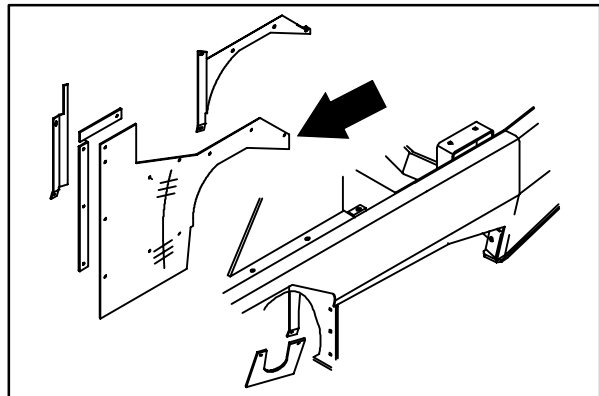

NOTE: The Power Throw™ brush must be removed on the model 810 to remove this seal. See TO REPLACE POWER THROW BRUSH instructions in this section.

7. Position the new brush compartment seal on the machine frame.
8. Align holes on new skirt with holes in retainers and frame.
9. Install and tighten the six M6 hex screws and nyloc nuts to 8 - 10 Nm (6 - 8 ft lb).
10. Push the five plastic rivets in by hand.

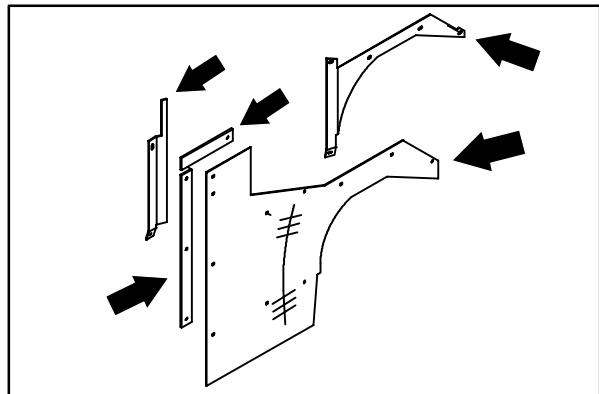

NOTE: The plastic rivets may need to be replaced if they were damaged during removal.

11. Repeat this procedure on the other side.

SWEEPING

HOPPER DOOR SEALS

The hopper door seals are located on the hopper door. They seal the hopper when the hopper door is closed.

Check the seals for wear or damage every 100 hours of operation.

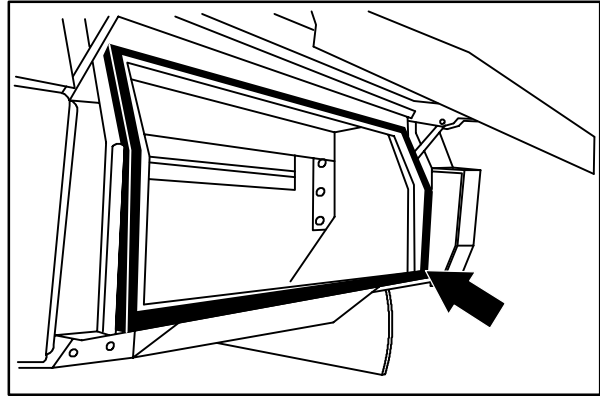

08497

HOPPER SIDE SKIRT

The hopper side skirt is located on the left side of the hopper.

Check the hopper side skirt for wear or damage daily.

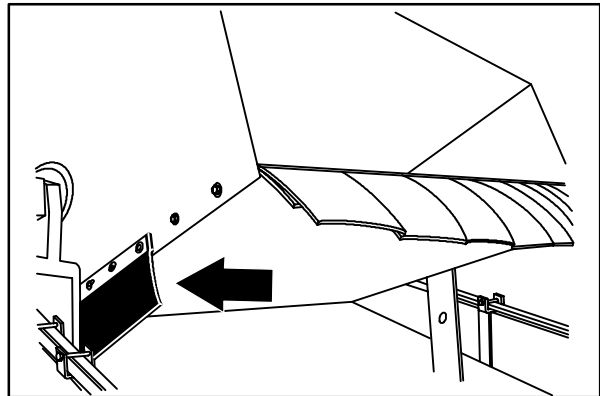

08492

HOPPER DUST SEAL

The hopper dust seal is located inside the hopper. It seals the hopper filter compartment.

Check the seal for wear or damage every 100 hours of operation.

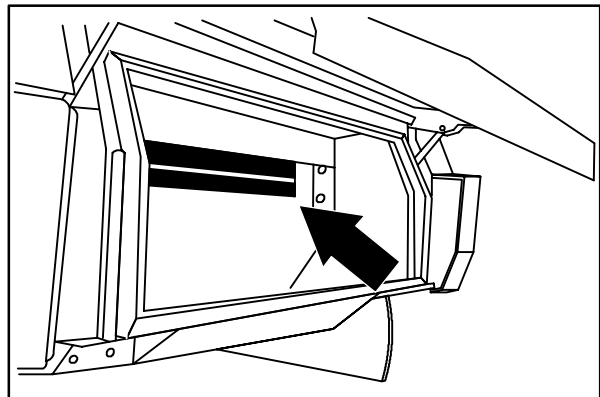

08498

HOPPER COVER SEAL

The hopper cover seals are located on the inside of the hopper cover. They seal the hopper filter compartment.

Check the seal for wear or damage every 100 hours of operation.



HOPPER LIFT ARMS

The hopper lift arms lift and lower the hopper assembly. They are held in place by pins and fiberglide bearings in the ends of the lift arms.

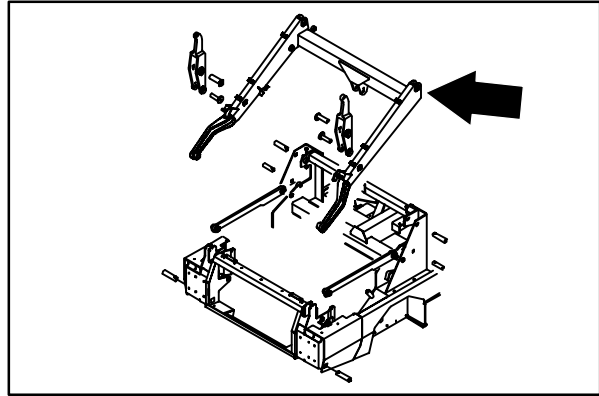

TO REMOVE HOPPER LIFT ARM

FOR SAFETY: Before Leaving Or Servicing Machine; Stop On Level Surface, Set Parking Brake, Turn Off Machine And Remove Key.

1. Remove debris hopper. See TO REMOVE HOPPER instructions in this section.
2. Make sure the lift arms are in the down position.
3. Trace the hydraulic hoses leading from the hopper roll out cylinders and hopper dump door cylinders back to the control valve.
4. Remove and plug these hoses at the control valve .

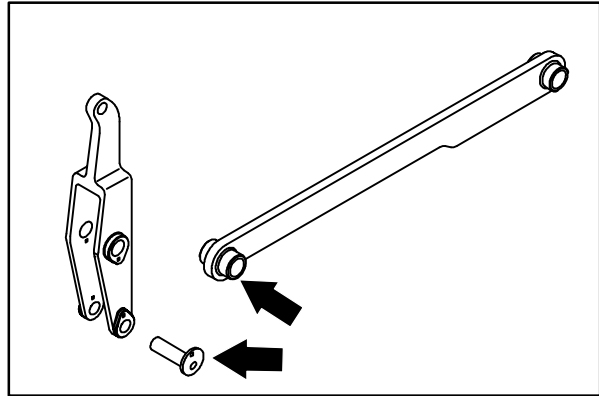

Note: Observe hydraulic cleanliness requirements when opening hydraulic lines.

5. Remove the pins connecting the black pivot link to the lower lift arm bar.
6. Remove the pin connecting the hopper lift arm to the hopper lift cylinder.
7. Remove the two M10 hex screws from the hopper lift arm upper pins.
8. Lift arms must now be lifted with a chain or cable so the pins can be removed.
9. Once the pins are removed the lift arm assembly can be lifted out of the machine.

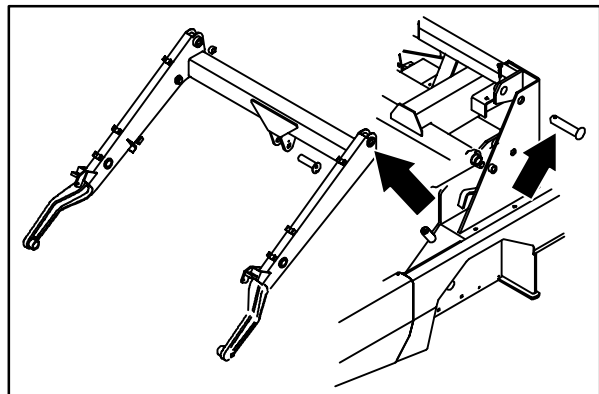
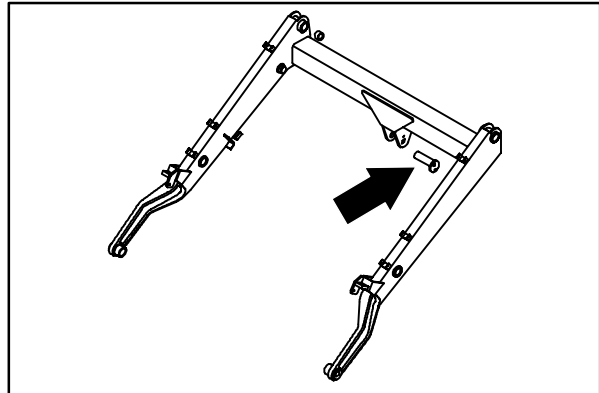

SWEEPING

TO INSTALL HOPPER LIFT ARM

FOR SAFETY: Before Leaving Or Servicing Machine; Stop On Level Surface, Set Parking Brake, Turn Off Machine And Remove Key.

1. Position the lift arm assembly back into the machine.
2. Align the upper holes in lift arm with the upper holes in main frame towers. Install pins and M10 hex screws. Hand tighten the hardware.
3. Align the holes in lower lift arm bar with the lower holes black pivot link. Install pins and M10 hex screws. Tighten to 37 - 48 Nm (26 - 34 ft lb).
4. Align the hole in the lift cylinder clevis with the holes in cylinder lift ears on hopper arm. Install pin and M10 hex screw. Tighten to 37 - 48 Nm (26 - 34 ft lb).
5. Reconnect roll out and dump door hydraulic hoses to control valve. See schematic in the HYDRAULICS section of this manual.
6. Reinstall debris hopper. See TO INSTALL HOPPER instructions in this section.

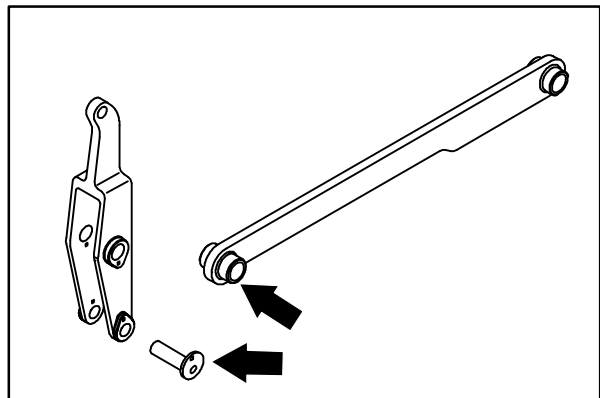
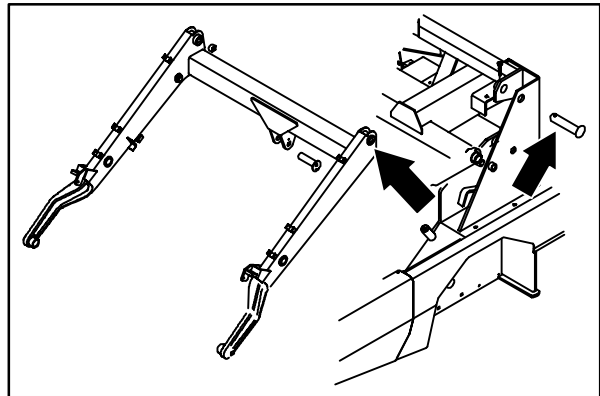
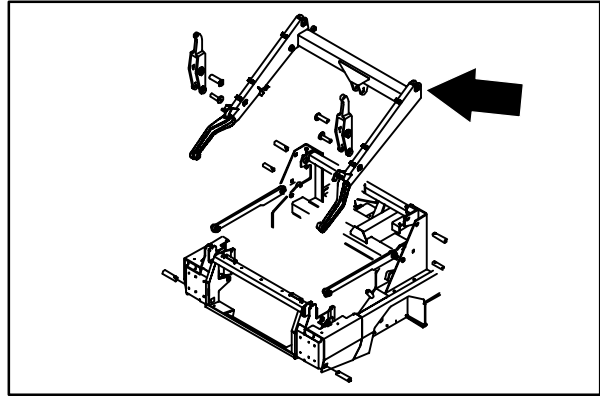

HOPPER VACUUM FAN SEAL

The hopper vacuum fan seal is mounted on the vacuum fan inlet bracket.

Check the seal for wear or damage every 100 hours of operation.

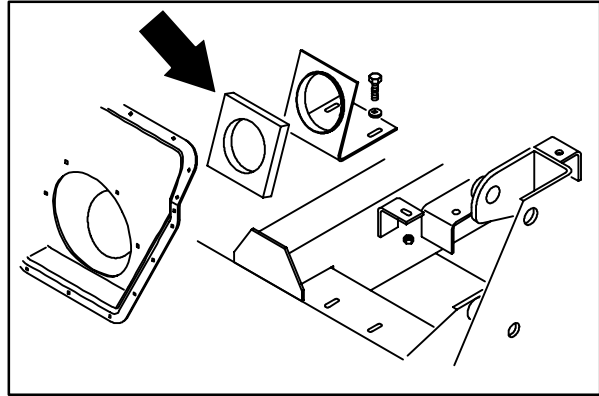

VACUUM FAN

The vacuum fan is hydraulically driven. It pulls air from the main brush area and through the hopper filters. There is no vacuum when the hopper is in the raised position.

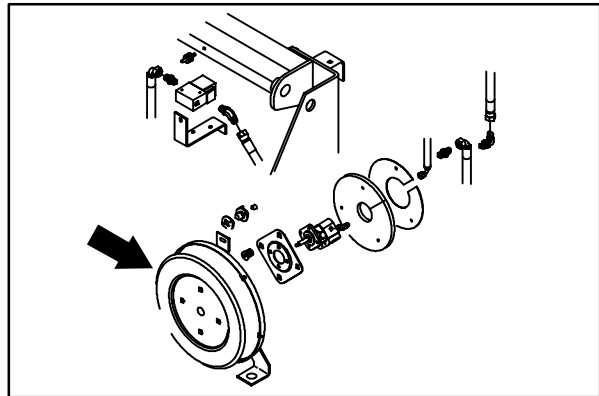

TO REPLACE VACUUM FAN IMPELLER

FOR SAFETY: Before Leaving Or Servicing Machine; Stop On Level Surface, Set Parking Brake, Turn Off Machine And Remove Key.

1. Dump the machine debris hopper.
2. Set the machine parking brake.
3. Raise the hopper, engage the hopper prop arm, and lower the hopper.

⚠ WARNING: Raised Hopper May Fall. Engage Hopper Support Bar.

4. Shut off the engine.
5. Open the engine cover and side door.

NOTE: The vacuum fan must be removed from the machine to replace the hydraulic motor.

6. Remove the vacuum hose and bracket from the front of vacuum fan housing.

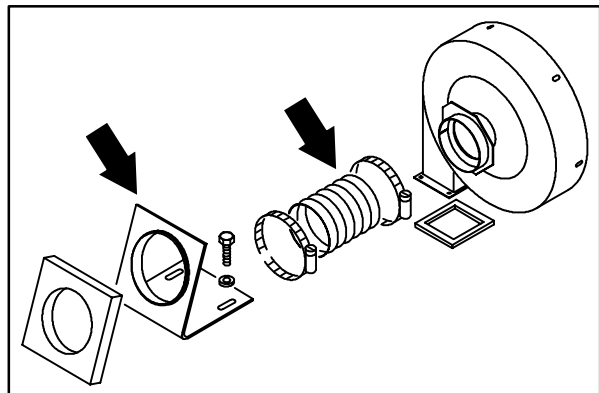
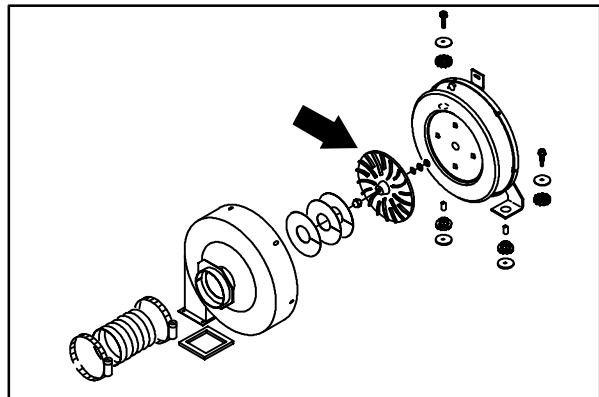

SWEEPING

7. Disconnect the wires leading to the thermo sentry™
8. Disconnect and plug the three hydraulic hoses at the vacuum fan motor.

NOTE: Observe hydraulic cleanliness requirements when opening hydraulic lines.

9. Remove the two M10 hex screws, washers and rubber isolators holding the vacuum fan housing to the machine frame.
10. Remove solenoid valve mounting bracket and rubber isolator from top of vacuum fan housing.
11. Tip the vacuum fan assembly forward and remove it from the machine.
12. Remove the six 0.31 in. hex screws holding the front housing to rear housing.

NOTE: Mark the orientation of the outer fan housing to the inner housing for proper re-assembly.

13. Remove the crown nut from the impeller shaft. Slide the impeller off the shaft. (Remove and save key and any shims on shaft under impeller.)
14. Turn the housing over and reinstall the shims, key, fan impeller, and crown nut. Tighten the crown nut to 34 - 47 Nm (25 - 35 ft lb).

NOTE: Use blue loctite 242 on shaft threads.

NOTE: Be sure key is in shaft. Super gluing key helps keep key in place.

NOTE: Make sure the impeller spins freely before continuing with the assembly.

15. Reinstall the front housing on the rear housing. Reinstall 0.31 in. hex screws and tighten to 22 - 27 Nm (16 - 20 ft lb).

NOTE: Tennant part no. 57543 plastic shims must be used for proper fan to housing clearance. Remove the shims through the fan intake after tightening screws.

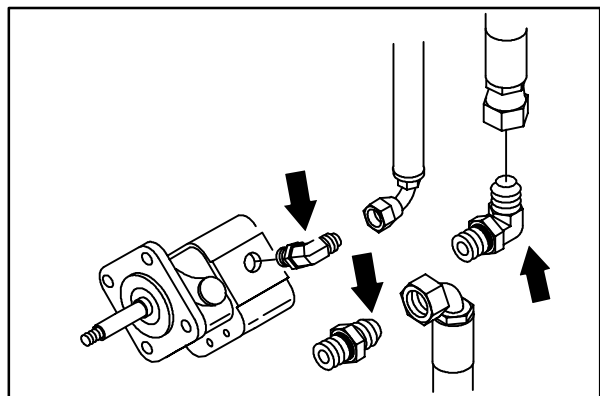
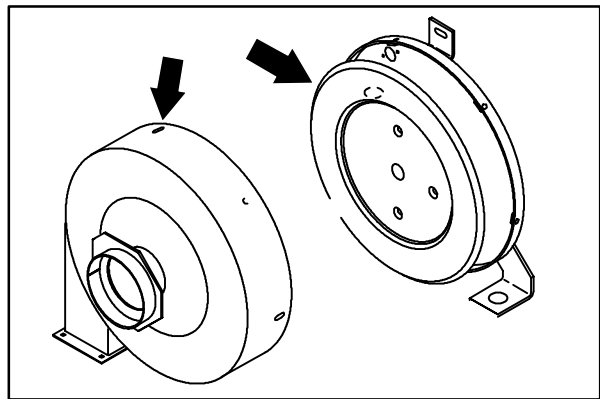
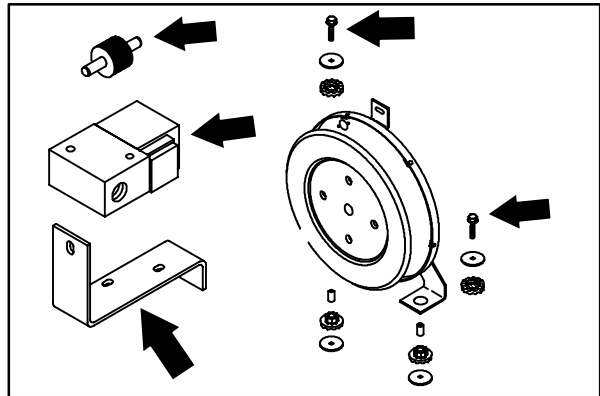
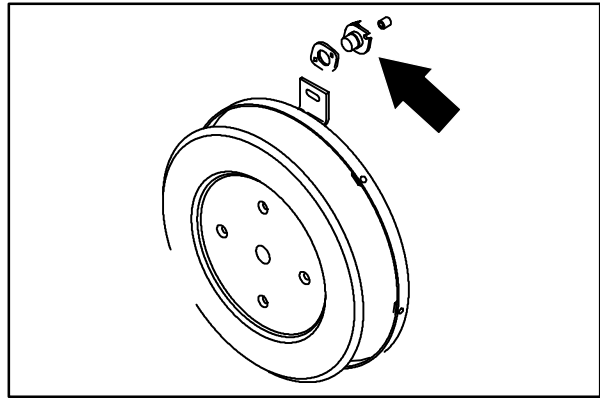

16. Reinstall the vacuum fan assembly into the machine. Tighten the M10 hex screws to 37 - 48 Nm (26 - 34 ft lb).
17. Reinstall the solenoid mount bracket and isolator to the top of fan assembly.
18. Reconnect the hydraulic hoses to the vacuum fan motor. See schematic in HYDRAULICS section.
19. Reinstall the vacuum hose and mounting bracket to the front of vacuum fan. Tighten the two M8 hex screws to 18 - 24 Nm (13 - 18 ft lb).
20. Reconnect the electrical harness to the thermo sentry™. See schematic in HYDRAULICS section.
21. Start the machine and operate the vacuum fan. Check for leaks and proper operation.

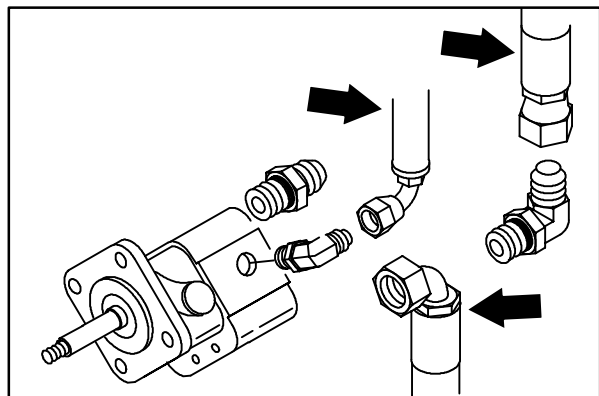
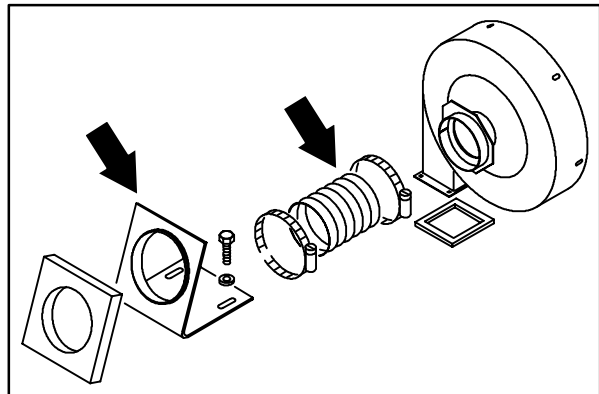
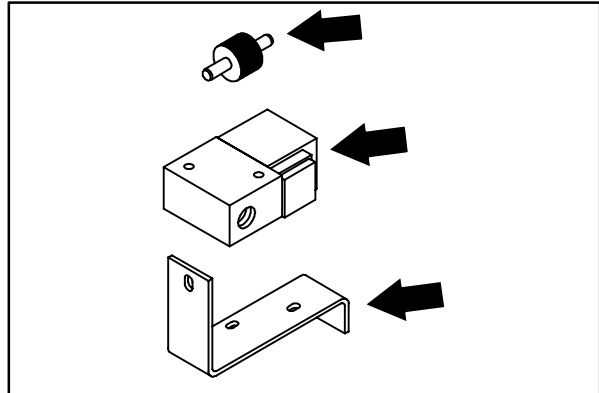
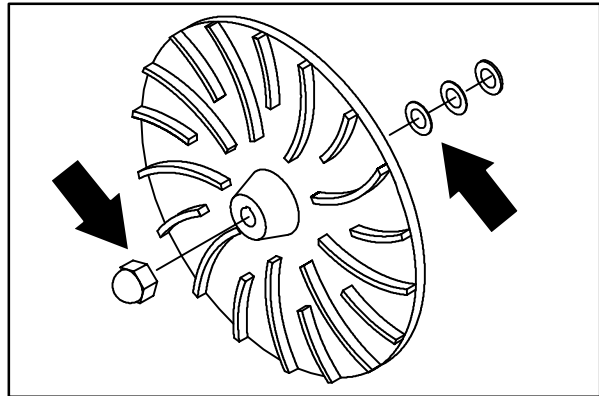

SWEEPING

MACHINE TROUBLESHOOTING

Problem	Cause	Remedy
<i>Excessive dusting</i>	Brush skirts and dust seals worn, damaged, out of adjustment	Replace or adjust brush skirts or dust seals
	Hopper dust filter clogged	Shake and/or clean or replace dust filter Also check operation and adjustment of shaker assembly
	Main brush operating Power Throw™ speed	Operate main brush in Normal speed
	Vacuum hose damaged	Replace vacuum hose
	Vacuum fan seal (vacuum fan inlet bracket) damaged	Replace seal
	Vacuum fan failure	Contact TENNANT service personnel
	Hopper door partially or completely closed	Open the hopper door
	Thermo Sentry™ tripped	Reset Thermo Sentry™
	Fabric prescreen missing on dust filters	Clean filter elements and install fabric prescreen
	Hopper cover not sealing	Repair/replace hopper cover seal, also check adjustment on hopper cover latch and hinge.
<i>Poor sweeping performance</i>	Brush bristles worn	Replace brushes
	Main and side brushes not adjusted properly	Adjust main and side brushes
	Debris caught in main brush drive mechanism	Free drive mechanism of debris
	Main brush drive failure	Contact TENNANT service personnel
	Side brush drive failure	Contact TENNANT service personnel
	Hopper full	Empty hopper
	Hopper floor skirts worn or damaged	Replace floor skirts
	Hopper door partially or completely open	Close the hopper door
	Wrong sweeping brush	Contact TENNANT representative for recommendations

CONTENTS

	Page		Page
ELECTRICAL SYSTEM	4-3	TROUBLESHOOTING	4-74
BATTERY	4-3	ENGINE RUN	4-75
TO REPLACE BATTERY ON LPG		SHAKER .. 4-76	
MACHINE AND GAS/DIESEL		SHAKER FAILURE	4-77
Serial # 002075 and up	4-4	VAC FAN .. 4-80	
TO REPLACE BATTERY ON GAS /		VACUUM FAN FAILURE	4-81
DIESEL MACHINE Serial # 002074		MAIN BRUSH	4-86
and down	4-5	MAIN BRUSH FAILURE	4-87
INSTRUMENT PANEL	4-6	SIDE BRUSH	4-89
TO REPLACE INSTRUMENT PANEL .	4-6	SIDE BRUSH FAILURE	4-90
TO DISASSEMBLE INSTRUMENT		HOPPER ROLL OUT	4-91
PANEL	4-7	HOPPER ROLLOUT FAILURE ...	4-92
TO REASSEMBLE INSTRUMENT		HEADLIGHT	4-93
PANEL	4-8	HEADLIGHT FAILURE	4-94
TO REPLACE MACHINE RELAY	4-9	WARNING LIGHT	4-97
TO REPLACE MACHINE CIRCUIT		WARNING LIGHT FAILURE	4-98
BREAKER	4-10	CLOGGED FILTER INDICATOR	
TO REPLACE GOVERNOR		CIRCUIT	4-101
CONTROL BOX	4-11	CLOGGED FILTER INDICATOR .	4-102
Electrical Schematic 800-810 G/LPG		HOPPER DOOR CIRCUIT	4-103
(LSG ENGINE)	4-12	HOPPER DOOR INDICATOR ...	4-104
Wire Harnesses Group 800-810 G/LPG		DOWN FORCE	4-105
(LSG ENGINE)	4-20	DOWN FORCE CIRCUIT	4-106
Electrical Schematic 800-810 G/LPG		FUEL SENDER CIRCUIT	
(LRG ENGINE)	4-32	(GAS AND DIESEL MACHINES)	4-107
Wire Harnesses Group 800-810 G/LPG		FUEL INDICATOR	
(LRG ENGINE)	4-40	(GAS AND DIESEL MACHINES)	4-108
Electrical Schematic 800-810 D		COOLANT SENDER CIRCUIT	4-109
(PERKINS 200 SERIES ENGINE) ...	4-52	COOLANT TEMPERATURE	4-110
Wire Harnesses Group 800-810 D		LOW LP CIRCUIT	
(PERKINS 200 SERIES ENGINE) ...	4-58	(L.P. MACHINES ONLY)	4-111
Electrical Schematic 800-810 D		LOW L.P. CIRCUIT	
(PERKINS 700 SERIES ENGINE) ...	4-68	(L.P. MACHINES ONLY)	4-112
		ALTERNATOR FAULT	4-113
		ALTERNATOR	4-114
		HOURMETER CIRCUIT	4-115
		HOURMETER WON'T WORK ..	4-116
		POWER UP CIRCUIT	4-117
		POWER UP TESTING	4-118
		800/810 RELAY AND CIRCUIT	
		BREAKER LOCATION	4-121

ELECTRICAL SYSTEM

The machine electrical system consists of the battery, alternator, and related components. This section includes information on these components and their troubleshooting.

BATTERY

The battery used in the machine is a low maintenance battery. It has been constructed with special materials and has extra electrolyte to reduce or eliminate maintenance. Its design reduces electrolyte loss and contamination. Do not add water, remove the battery vent plugs, or check the battery specific gravity. For specific instructions, see the battery label.

Do not allow the battery to remain in discharged condition for any time. Do not operate the machine if the battery is in poor condition or discharged beyond 80%, specific gravity below 1.120.

Periodically clean the top surface of the batteries and the terminals, and check for loose connections. Use a strong solution of baking soda and water. Brush the solution sparingly over the battery tops, terminals, and cable clamps. Do not allow any baking soda solution to enter the batteries. Use a wire brush to clean the terminal posts and the cable connectors. After cleaning, apply a coating of clear battery post protectant to the terminals and the cable connectors. Keep the tops of the batteries clean and dry.

Keep all metallic objects off the top of the batteries, which may cause a short circuit. Replace any worn or damaged wires.

The electrolyte level in regular non sealed batteries can be checked. The level must always be above the battery plates. Never add acid to the batteries, only distilled water. Keep the battery caps on the batteries always except when adding water or taking hydrometer readings.

FOR SAFETY: When Servicing Machine, Avoid Contact With Battery Acid.

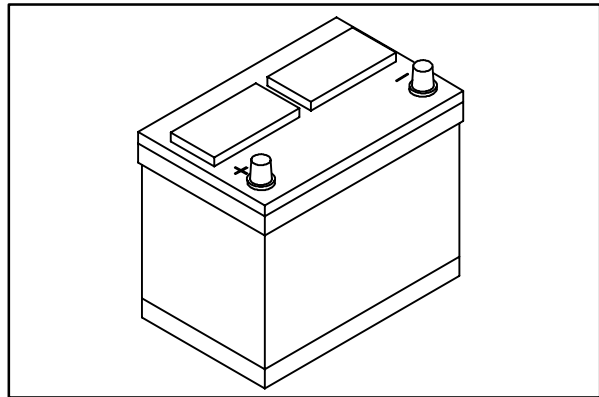

ELECTRICAL

Using a hydrometer to measure the specific gravity is a way to determine the charge level and condition of the batteries. If one or more of the battery cells test lower than the other battery cells (0.050 or more), the cell is damaged, shorted, or is about to fail.

NOTE: Do not take readings immediately after adding distilled water. If the water and acid are not thoroughly mixed, the readings may not be accurate. Check the hydrometer readings against the following chart to determine the remaining battery charge level:

SPECIFIC GRAVITY at 27° C (80° F)	BATTERY CHARGE
1.260 - 1.280	100% Charged
1.230 - 1.250	75% Charged
1.200 - 1.220	50% Charged
1.170 - 1.190	25% Charged
1.110 - 1.160	Discharged

NOTE: If the readings are taken when the battery electrolyte is any temperature other than 27° C (80° F), the reading must be temperature corrected. Add or subtract to the specific gravity reading 0.004, 4 points, for each 6° C (10° F) above or below 27° C (80° F).

TO REPLACE BATTERY ON LPG MACHINE AND GAS/DIESEL Serial # 002075 and up

FOR SAFETY: Before Leaving Or Servicing Machine; Stop On Level Surface, Set Parking Brake, Turn Off Machine And Remove Key.

1. Lift the engine cover and open the side door.
2. Disconnect the negative then the positive battery cables.
3. Remove the small battery hold down bracket from machine.
4. Tilt the battery towards you and lift it up and out.
5. Clean the old cables and the posts on the new battery.
6. Lift the new battery up and onto the battery tray.
7. Reinstall the small battery hold down bracket.
8. Reconnect the positive then the negative battery cables.

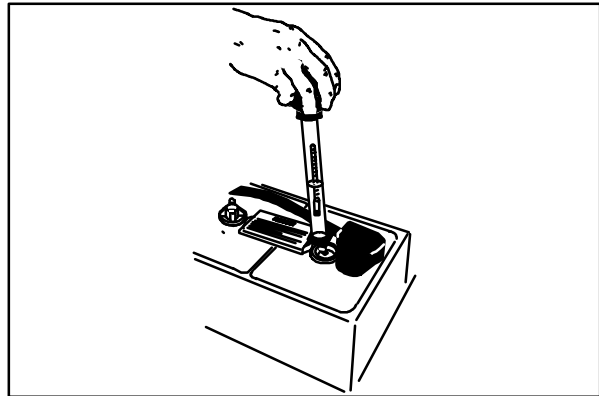

04380

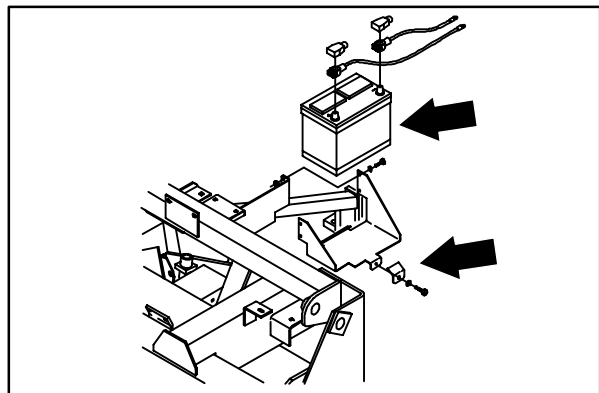

**TO REPLACE BATTERY ON GAS / DIESEL
MACHINE Serial # 002074 and down**

**FOR SAFETY: Before Leaving Or Servicing
Machine; Stop On Level Surface, Set Parking
Brake, Turn Off Machine And Remove Key.**

1. Open the battery access door located at the right rear of the machine.
2. Disconnect the negative then the positive battery cables.
3. Remove the battery hold down bracket from the machine.
4. Slide the battery towards you and lift it out.
5. Clean the old cables and the posts on the new battery.
6. Lift the new battery up and slide it into the battery tray.
7. Reinstall the battery hold down bracket.
8. Reconnect the positive then the negative battery cables.
9. Close the battery access door.

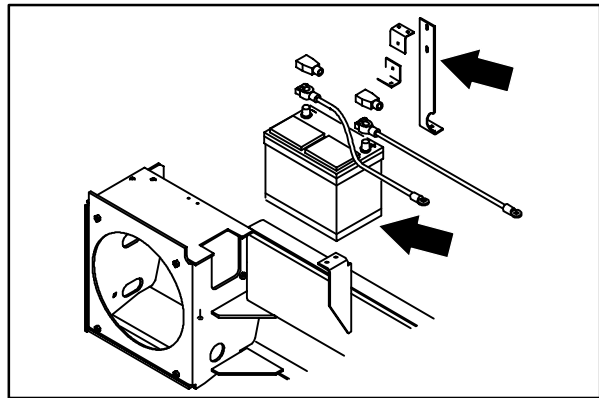
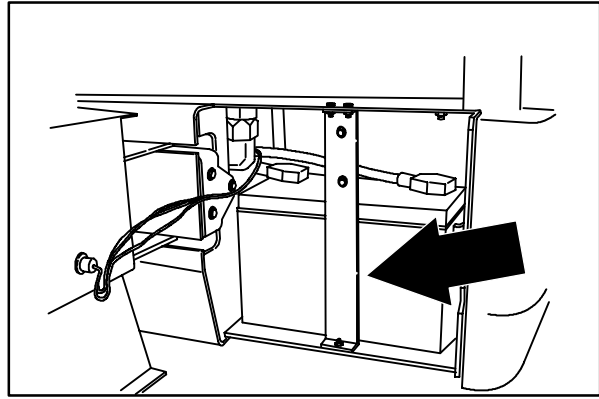

INSTRUMENT PANEL

The instrument panel consists of a circuit board, a touch panel, and a water/dust resistant plastic enclosure. The touch panel controls various machine functions, while its indicator lights keep the operator informed on machine performance.

TO REPLACE INSTRUMENT PANEL

FOR SAFETY: Before Leaving Or Servicing Machine; Stop On Level Surface, Set Parking Brake, Turn Off Machine And Remove Key.

1. Remove the battery cables from the battery.
2. Remove the three plastic knobs from the valve handles.
3. Place the steering wheel in lowest position.
4. Remove the eight M6 pan head screws from the dash panel.
5. Pull the dash panel towards you until it clears the valve handles.
6. Loosen the allen head screw in center of instrument panel wire harness plug. Unplug the harness from the panel.
7. Remove the four M5 hex screws holding the instrument panel to the dash panel. Remove the instrument panel from the machine and repair or replace it.
8. Position the new instrument panel back on the dash panel. Reinstall the four M5 hex screws and washers. **Lightly** hand tighten this hardware.
9. Push the main harness plug back into the instrument panel receptacle.

NOTE: The slot in the instrument panel receptacle must line up with the notch on main harness plug. **Lightly** hand tighten the allen head screw.

10. Reinstall the dash panel on the machine using the eight M6 pan head screws. Tighten to 8 - 10 Nm (5 - 6 ft lb).
11. Reinstall the three plastic knobs on valve handles. Hand tighten.
12. Reconnect the battery cables.
13. Start the machine and check for proper operation of the instrument panel.

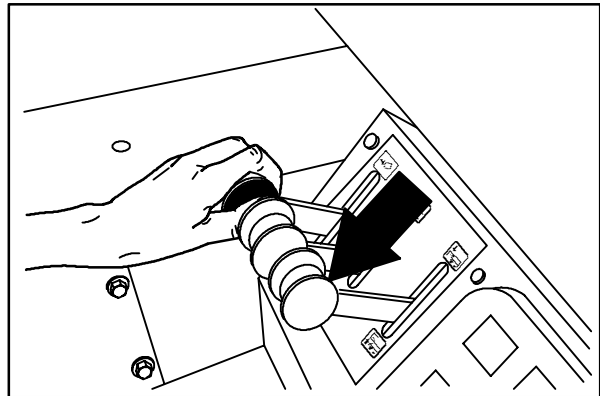
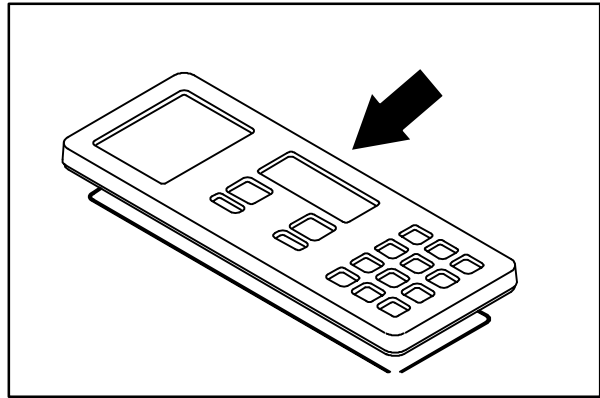

08475

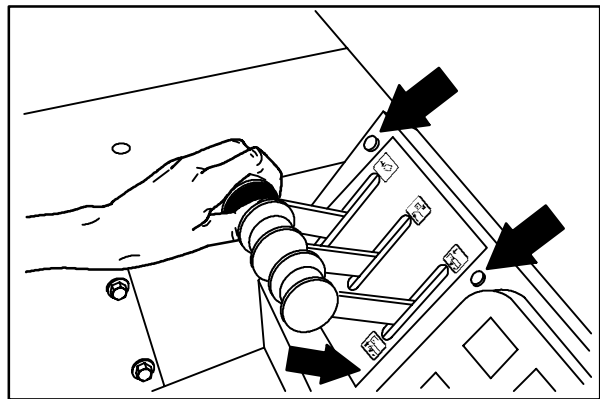

08475

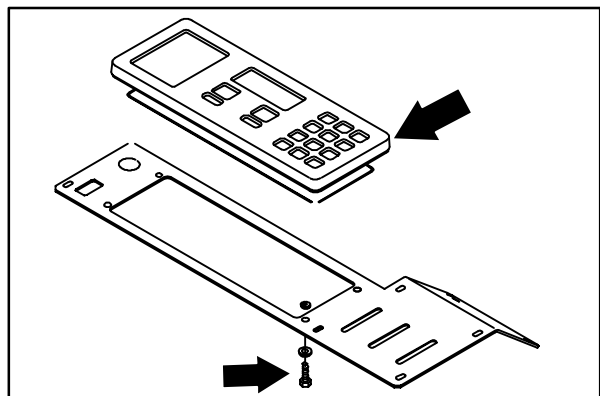

TO DISASSEMBLE INSTRUMENT PANEL

FOR SAFETY: Before Leaving Or Servicing Machine; Stop On Level Surface, Set Parking Brake, Turn Off Machine And Remove Key.

1. Remove the instrument panel from the machine. See TO REPLACE INSTRUMENT PANEL instructions in this section.
2. Place the instrument panel face down and remove the twelve larger pan head screws.
3. The touch panel case can now be separated from outer case and new o-ring gasket installed if necessary.
4. To disassemble the touch panel case further, remove the four smaller pan head screws from the center of case box.
5. Remove the case box from the circuit board touch panel assembly.
6. The o-ring and connector gaskets can now be replaced in the case box if necessary.
7. Remove the eight smaller pan head screws, unplug the flat connector and ground strap. Remove the touch panel from the circuit board.
8. Any burned-out lamps can now be changed by turning them 1/4 turn counterclockwise and lifting them straight out.
9. To replace the hour meter, unplug the two wires and remove the two pan head screws.

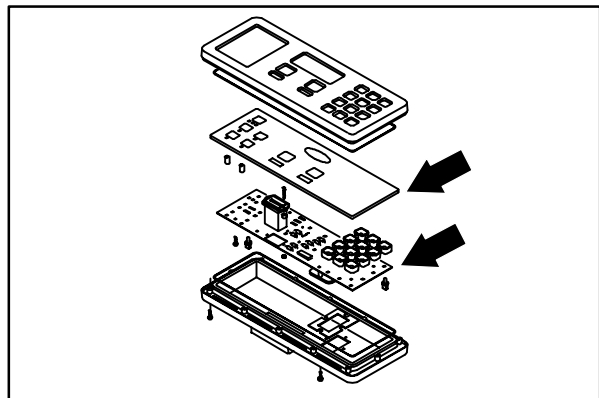
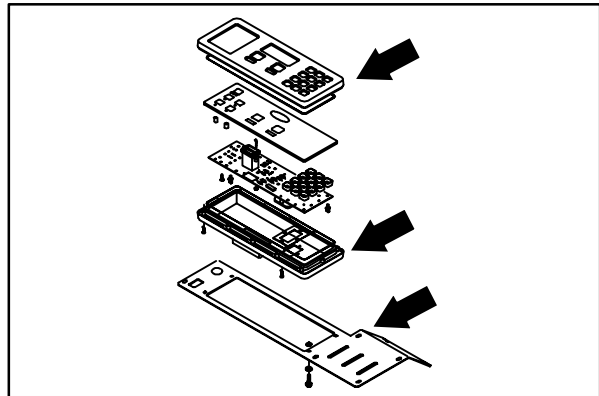
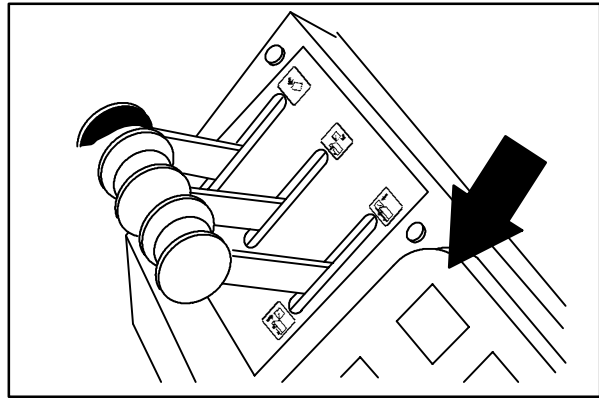

ELECTRICAL

TO REASSEMBLE INSTRUMENT PANEL

FOR SAFETY: Before Leaving Or Servicing Machine; Stop On Level Surface, Set Parking Brake, Turn Off Machine And Remove Key.

1. Position the circuit board over the touch panel.
2. Feed the flat connector from the panel through the slot in the board. Plug the connector in and reconnect the ground strap.
3. Reinstall the eight smaller pan head screws and lightly hand tighten.
4. Turn the circuit board assembly over and place it back in the case box.
5. Reinstall the four smaller pan head screws in the center of the case box.
6. Reinstall the touch panel case onto the outer case.
7. Reinstall the twelve pan head screws and lightly hand tighten.
8. The instrument panel is now ready to be reinstalled in machine. See TO REPLACE INSTRUMENT PANEL instructions in this section.

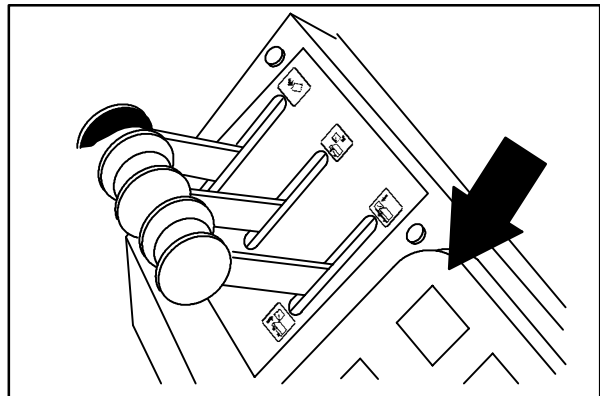
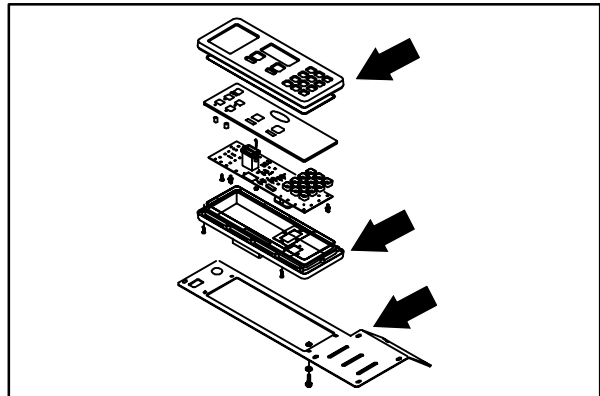
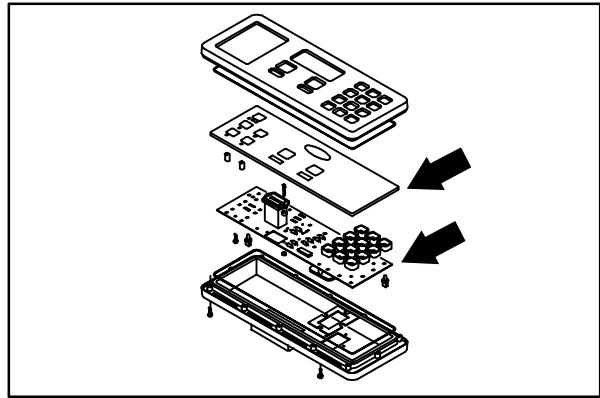

TO REPLACE MACHINE RELAY

FOR SAFETY: Before Leaving Or Servicing Machine; Stop On Level Surface, Set Parking Brake, Turn Off Machine And Remove Key.

1. Make sure the hopper has been emptied of all debris.
2. Set the parking brake, Raise the hopper and engage the prop arm.

⚠ WARNING: Raised Hopper May Fall. Engage Hopper Support Bar.

3. Remove the battery cables from the battery.
4. Go in machine under the hopper by the dust shield. Lift the dust shield and prop it out of the way.
5. Remove the four M6 nyloc nuts and washers holding the plastic relay cover in place. Pull the cover back far enough to allow access to the relays.
6. Locate the relay that needs replacing. Un-plug the main electrical harness from that relay.
7. Remove the M6 nyloc nut holding the relay to the relay plate. Remove and discard the relay.
8. Position the new relay on the threaded stud on the relay plate. Reinstall the M6 nyloc nut and hand tighten.
9. Plug the main harness into the new relay. See electrical schematic in this section.
10. Reinstall the plastic relay cover. Hand tighten the four M6 nuts and washers.
11. Drop the dust shield back in place.
12. Reconnect the battery cables.
13. Disengage the prop arm, lower the hopper and operate the machine. Check the new relay for proper operation.

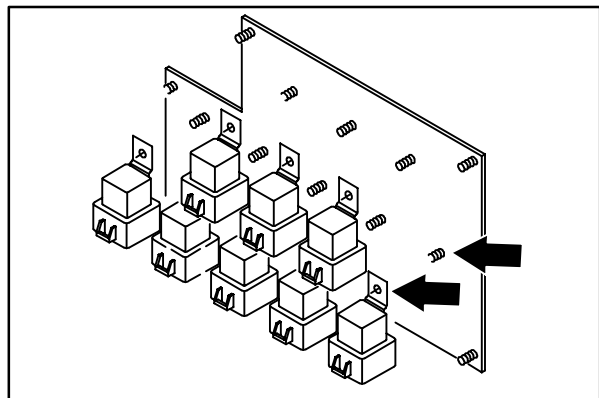
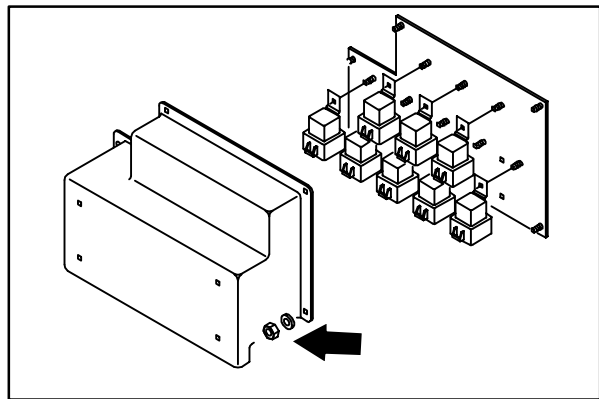
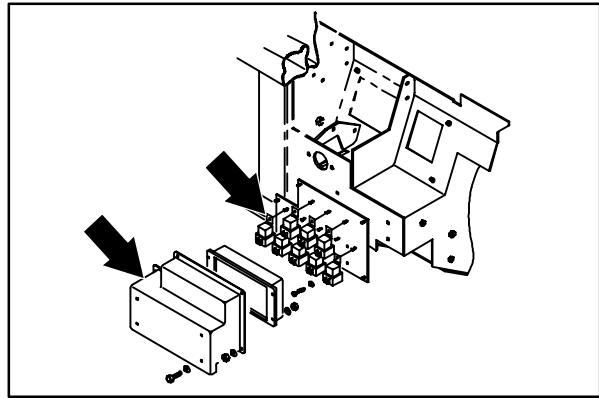

TO REPLACE MACHINE CIRCUIT BREAKER

FOR SAFETY: Before Leaving Or Servicing Machine; Stop On Level Surface, Set Parking Brake, Turn Off Machine And Remove Key.

1. Remove the battery cables from the battery.
2. Go in the machine operators compartment and locate the removable circuit breaker plate.
3. Remove the six M6 screws holding the removable circuit breaker panel to the machine. Pull the panel back far enough to allow access to the wires on the circuit breakers.
4. Locate the circuit breaker that needs to be replaced. Remove the wires leading to that circuit breaker.
5. The round, metal lock ring, that is holding the circuit breaker to the panel, must be removed.

NOTE: A new lock ring is provided with the new circuit breaker in case the old one is damaged during the removal procedure.

6. Pull the old circuit breaker out of the hole and discard it. Retain the clear rubber boot.

NOTE: Re-use the clear rubber boot on the new circuit breaker.

7. Position the new circuit breaker in the panel.

NOTE: The circuit breaker is "D" shaped and will only go in the hole one way.

8. Install the lock ring on the new circuit breaker. Push it down all the way to the panel.
9. Reconnect the wires to the new circuit breaker. See electrical schematic in this section.
10. Reinstall the circuit breaker plate to the machine. Tighten the six M6 screws to 8 - 10 Nm (5 - 6 ft lb).
11. Reconnect the battery cables and start the machine, checking for proper circuit breaker operation.

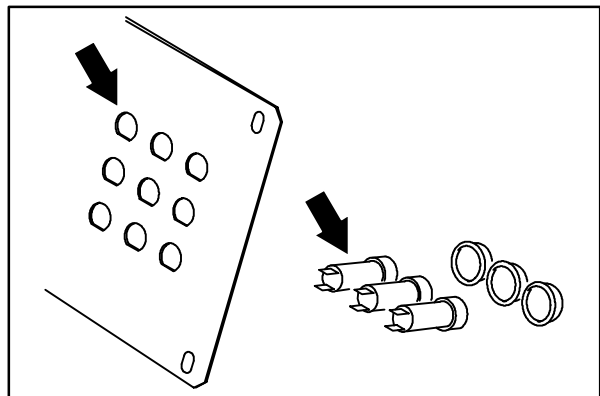
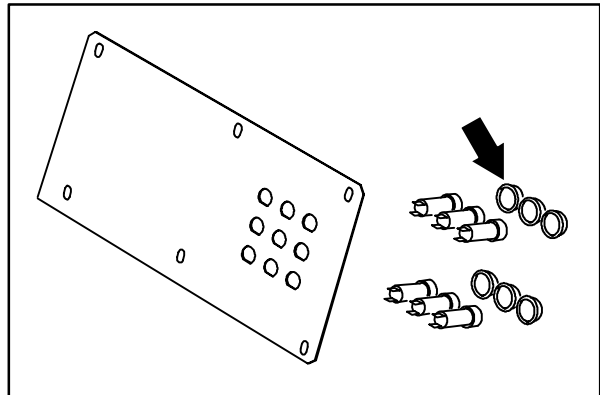
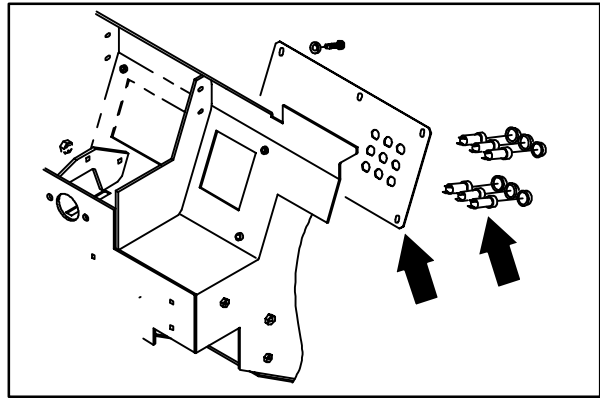

TO REPLACE GOVERNOR CONTROL BOX

FOR SAFETY: Before Leaving Or Servicing Machine; Stop On Level Surface, Set Parking Brake, Turn Off Machine And Remove Key.

1. Make sure the hopper has been emptied of all debris.
2. Set the parking brake, Raise the hopper and engage the prop arm.

⚠ WARNING: Raised Hopper May Fall. Engage Hopper Support Bar.

3. Remove the battery cables from the battery.
4. Go in machine under the hopper by the dust shield. Lift the dust shield and prop it out of the way.
5. Remove the four M6 nyloc nuts and washers holding the plastic relay cover in place. Pull the cover back far enough to allow access to the governor control box.
6. Unplug the governor control box from the main electrical harness.
7. Remove the hex screws holding the governor control box to the plastic relay panel. Remove the governor control box from the machine.
8. Position the new governor control box on the plastic relay panel. Hand tighten the hex screws.
9. Plug the new governor control box into the main harness. See electrical schematic in this section.
10. Reinstall the plastic relay cover. Hand tighten the four M6 nuts and washers.
11. Drop the dust shield back in place.
12. Reconnect the battery cables.
13. Disengage the prop arm, lower the hopper and operate the machine. Check the new governor control box for proper operation.

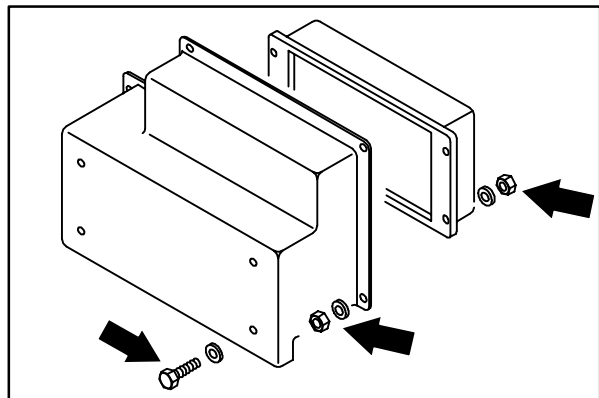
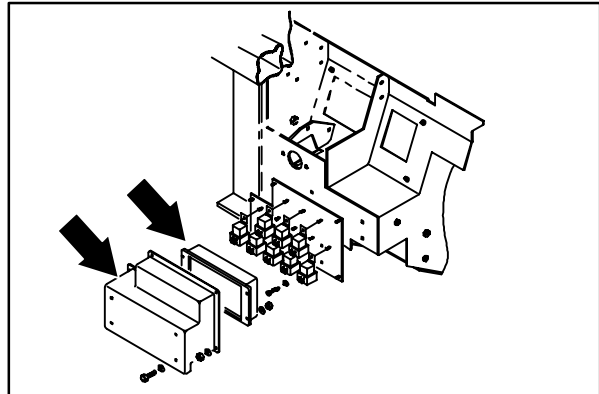

Electrical Schematic 800-810 G/LPG (LSG ENGINE)

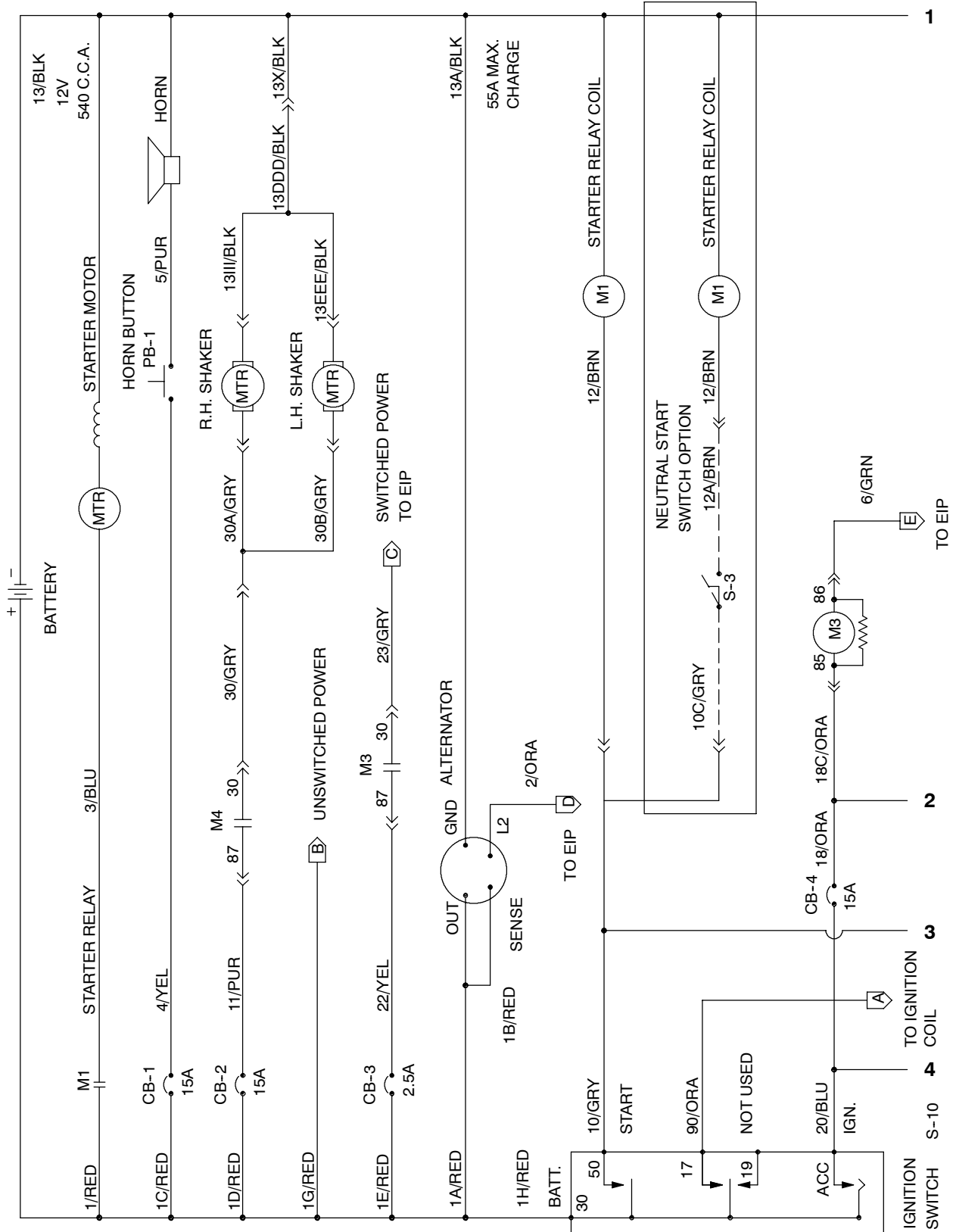

Electrical Schematic 800-810 G/LPG (LSG ENGINE)

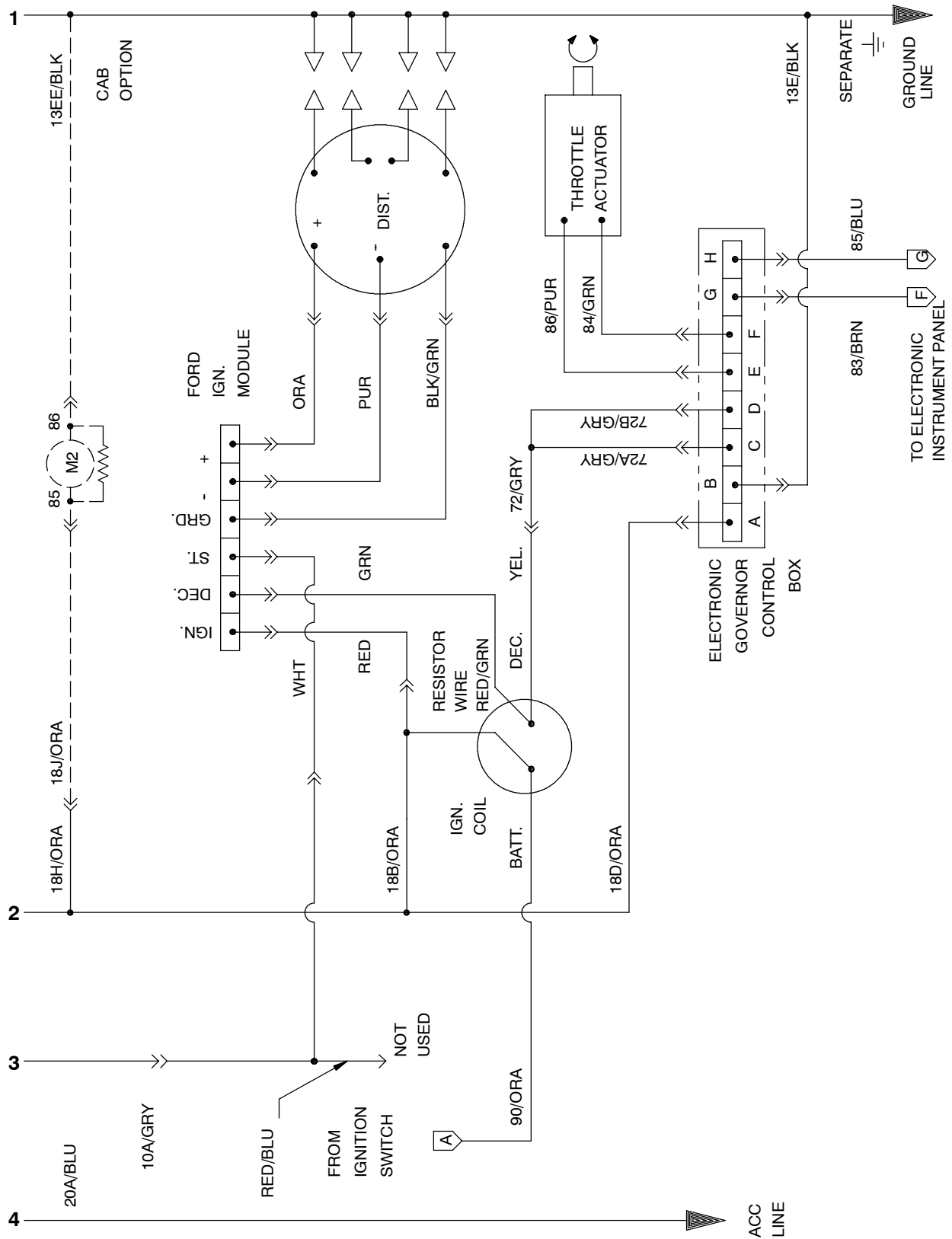

Electrical Schematic 800-810 G/LPG (LSG ENGINE)

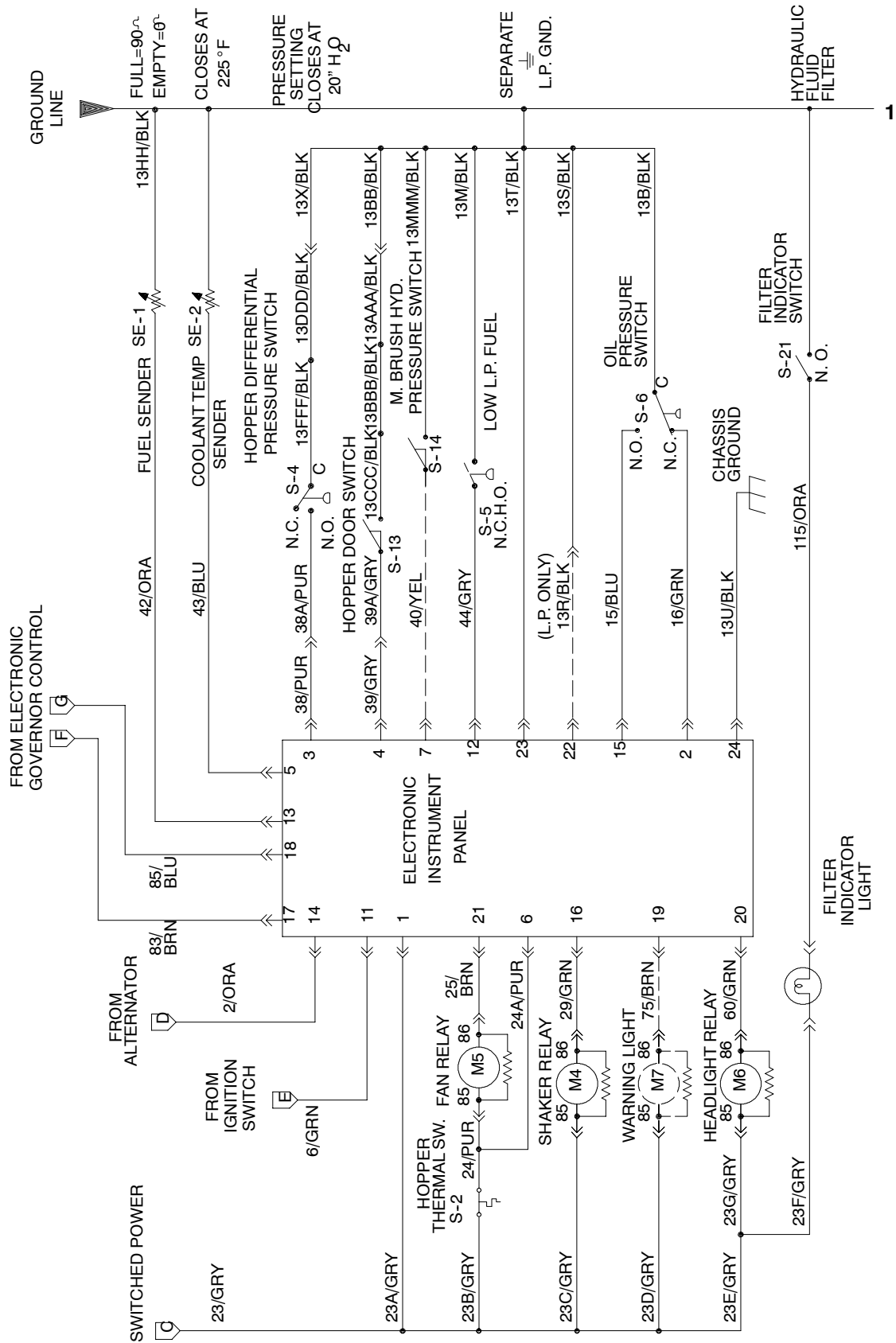

Electrical Schematic 800-810 G/LPG (LSG ENGINE)

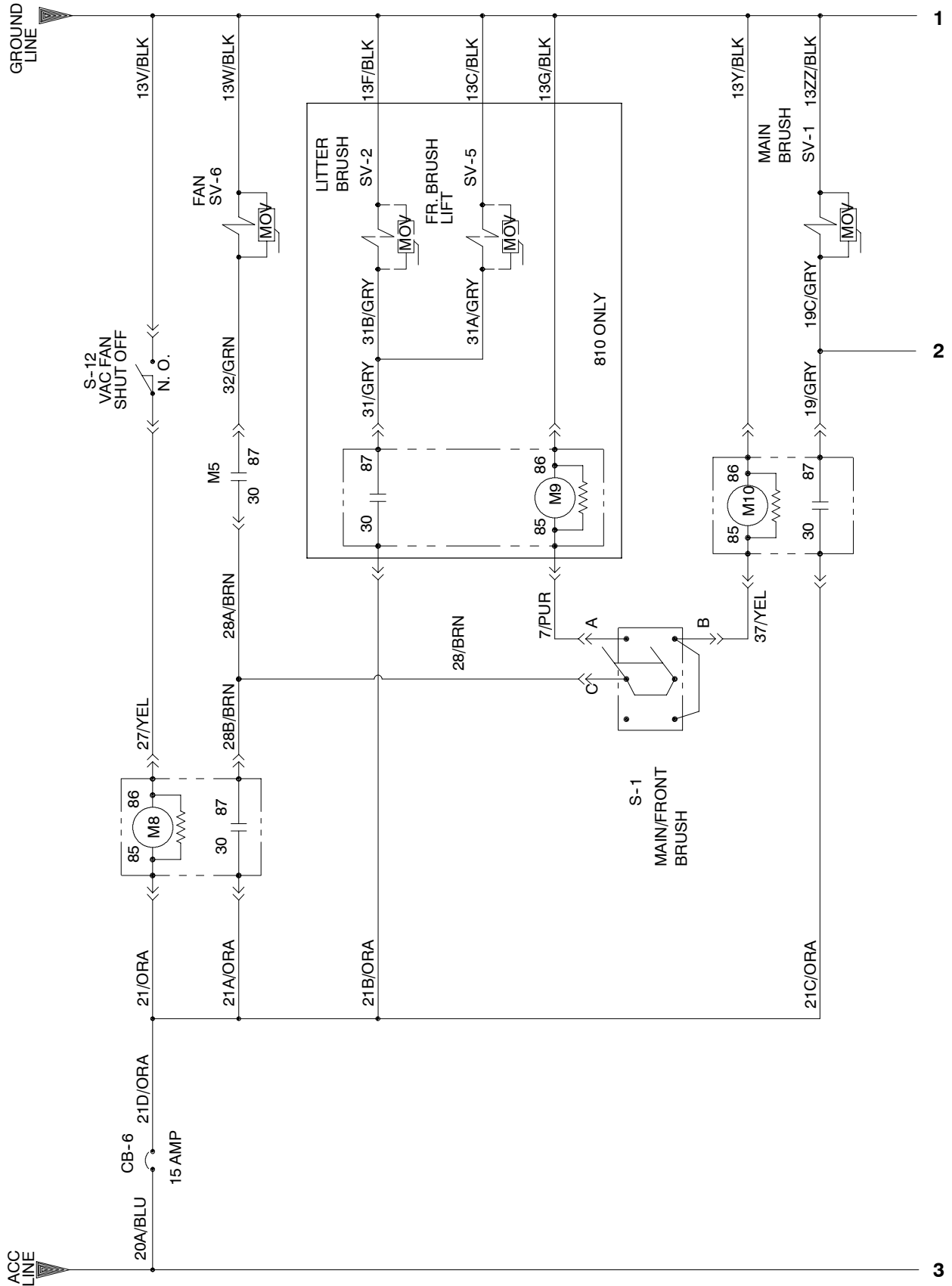

Electrical Schematic 800-810 G/LPG (LSG ENGINE)

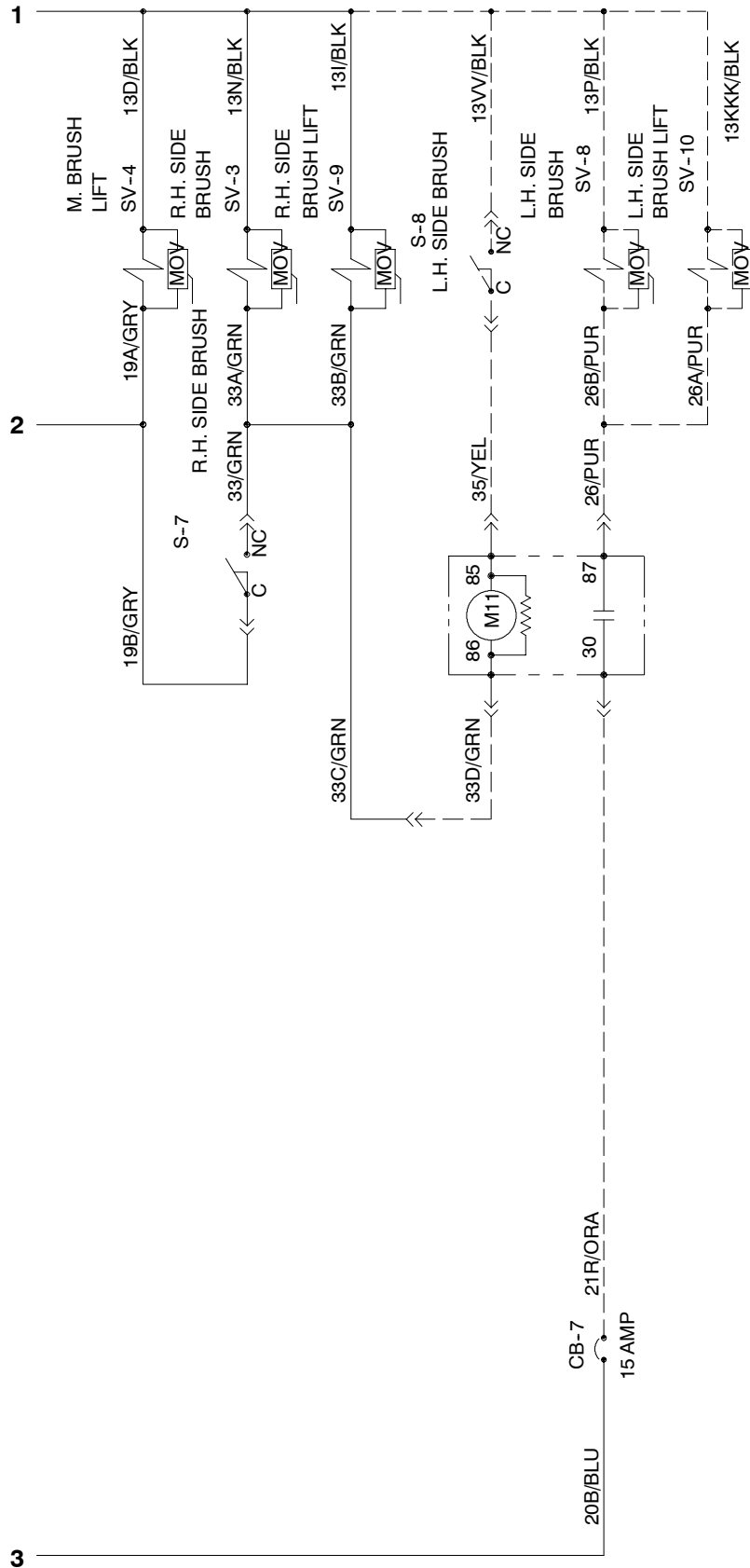

LEGEND	
M	POWER RELAY
MTR	MOTOR
CB	CIRCUIT BREAKER
PM	PERMANENT MAGNET
J	JACK-FEM. SOCKET
P	PLUG-MALE PIN
PB	PUSHBUTTON
VM	VOLTMETER
FU	FUSE
HM	HOURLMETER
SV	SOLENOID VALVE
S	SWITCH
ACC	ACCESSORY
GND	GROUND CHASSIS
C	COMMON
N.O.	NORMALLY OPEN
N.C.	NORMALLY CLOSED
NOV	METAL OXIDE VARISTOR

Electrical Schematic 800-810 G/LPG (LSG ENGINE)

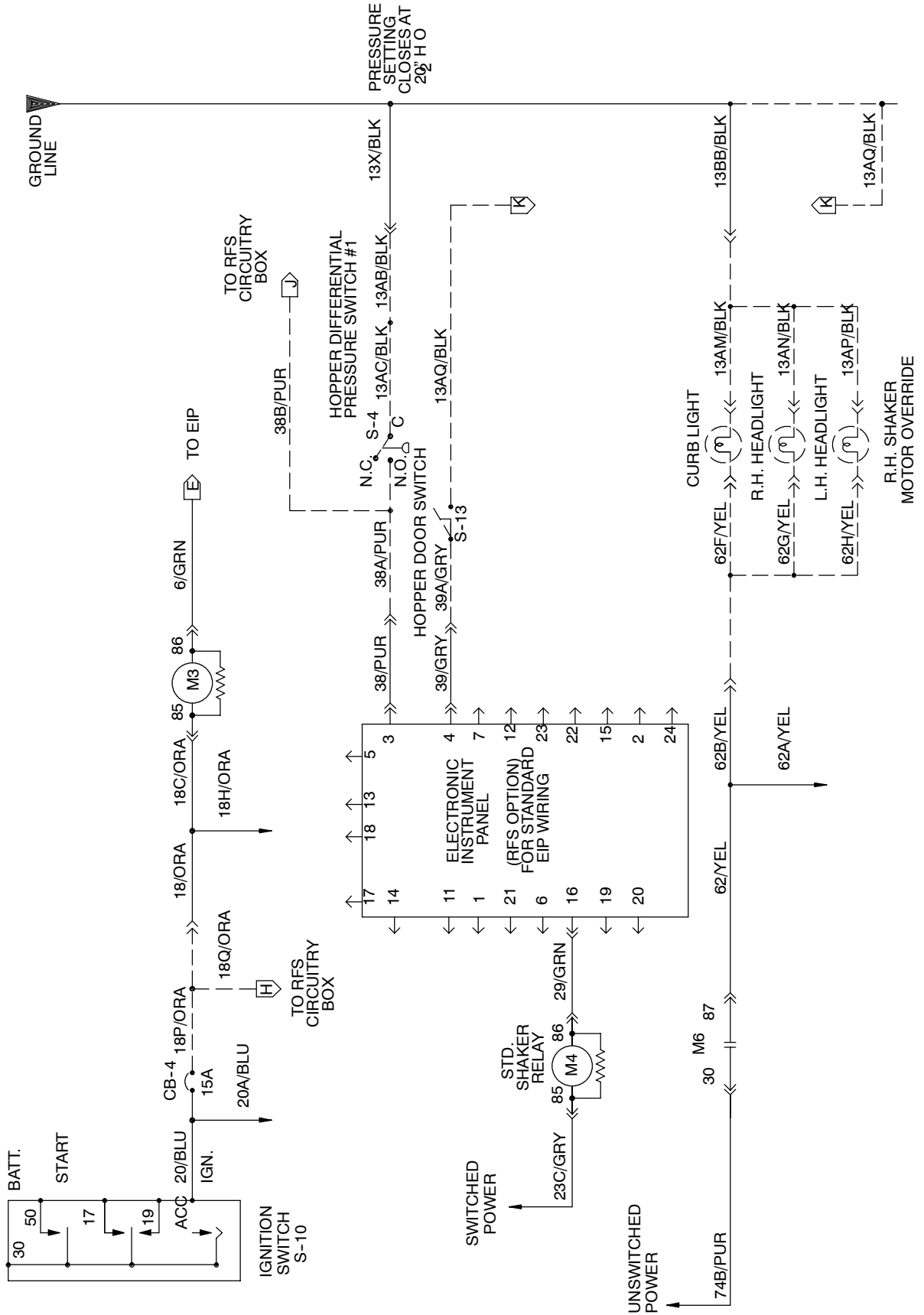

Electrical Schematic 800-810 G/LPG (LSG ENGINE)

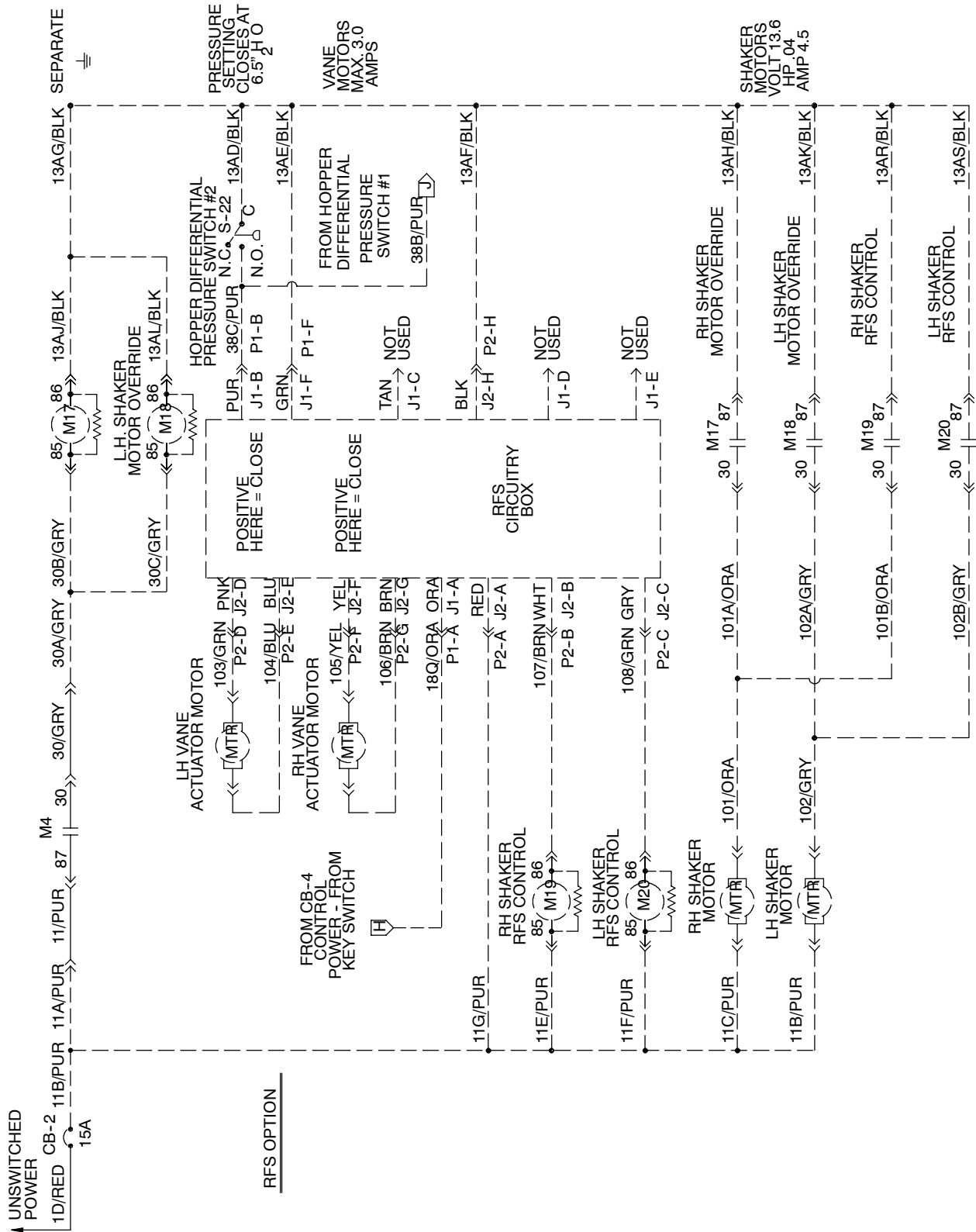

ELECTRICAL

Wire Harnesses Group 800-810 G/LPG (LSG ENGINE)

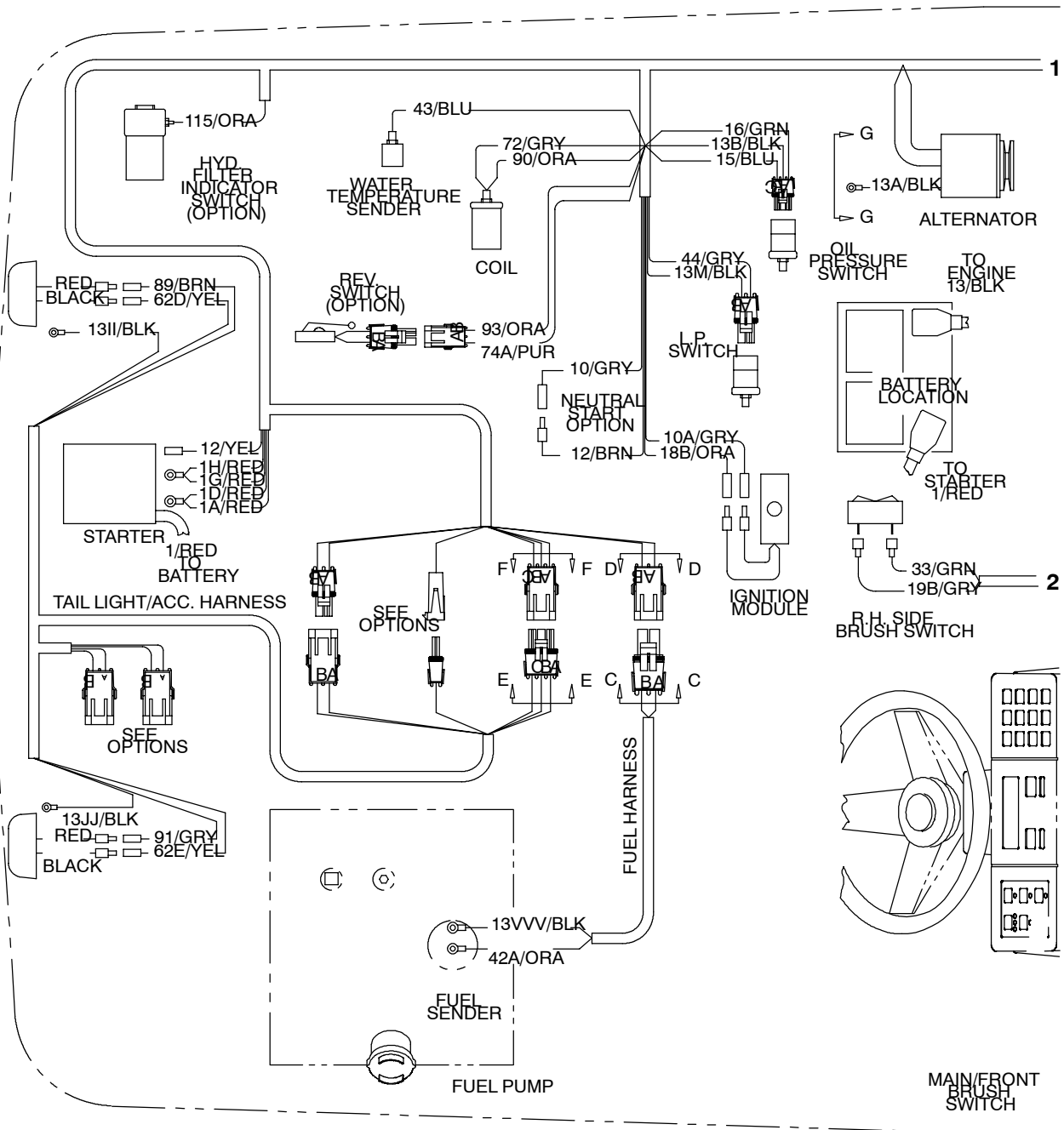

SOCKET NO.	WIRE NO.	COLOR	SOCKET NO.	WIRE NO.	COLOR	SOCKET NO.	WIRE NO.	COLOR	SOCKET NO.	WIRE NO.	COLOR
1	23A	GRY	7	40	YEL	13	42	ORA	19	75	BRN
2	16	GRN	8	PLUG	—	14	2	ORA	20	60	GRN
3	38	PUR	9	PLUG	—	15	15	BLU	21	25	BRN
4	39	GRY	10	PLUG	—	16	29	GRN	22	13R	BLK
5	43	BLU	11	6	GRN	17	83	BRN	23	13T	BLK
6	24A	PUR	12	44	GRY	18	85	BLU	24	13U	BLK

Wire Harnesses Group 800-810 G/LPG (LSG ENGINE)

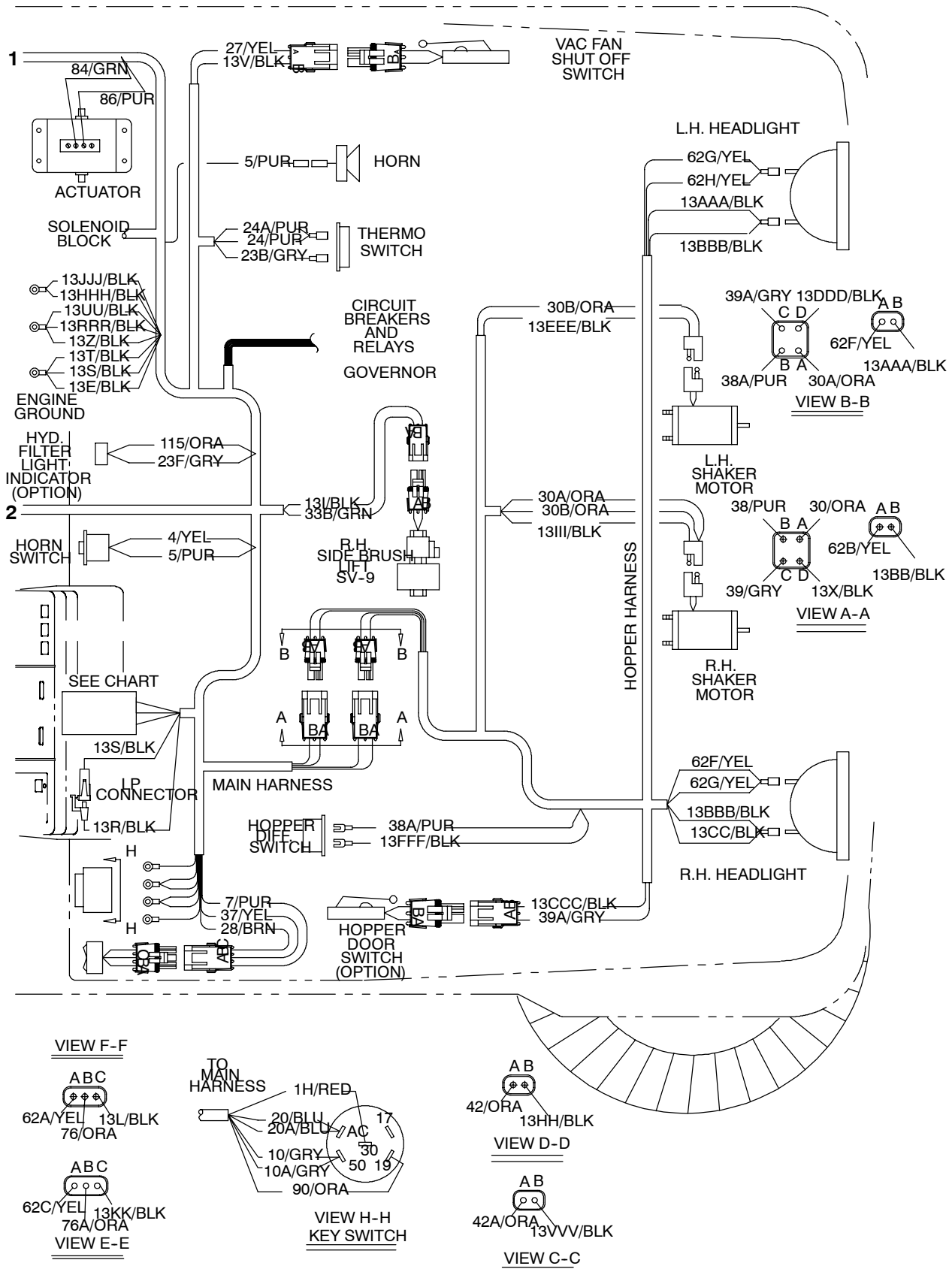

Wire Harnesses Group 800-810 G/LPG (LSG ENGINE)

RELAYS

- M3 ELECTRONIC INSTRUMENT PANEL
- M4 SHAKER MOTOR
- M5 VAC FAN SOLENOID
- M6 HEADLIGHTS
- M7 ROTATING/FLASHING LIGHTS
- M8 HOPPER LIFT
- M9 FRONT BRUSH
- M10 MAIN BRUSH

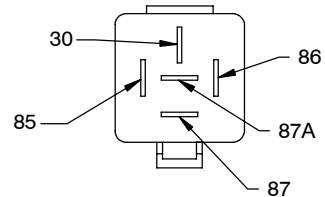
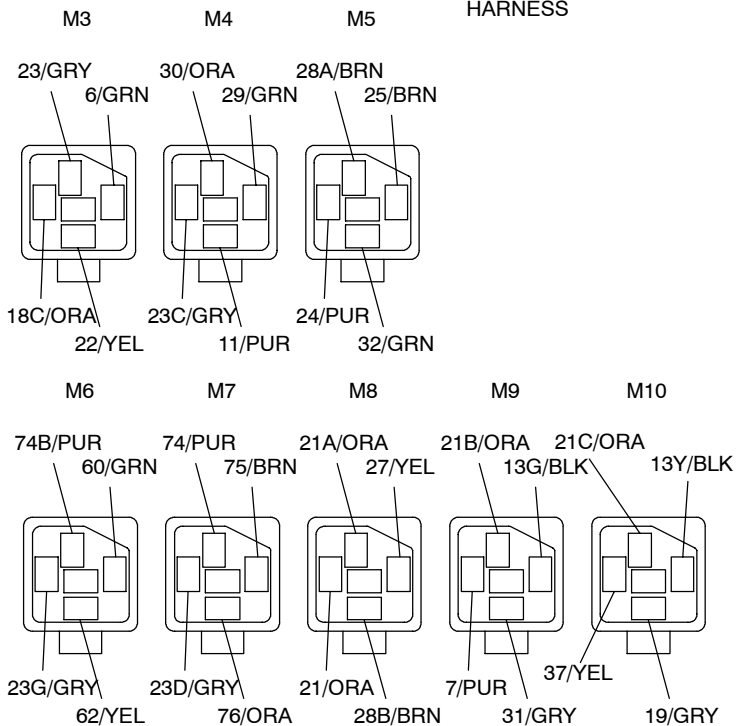
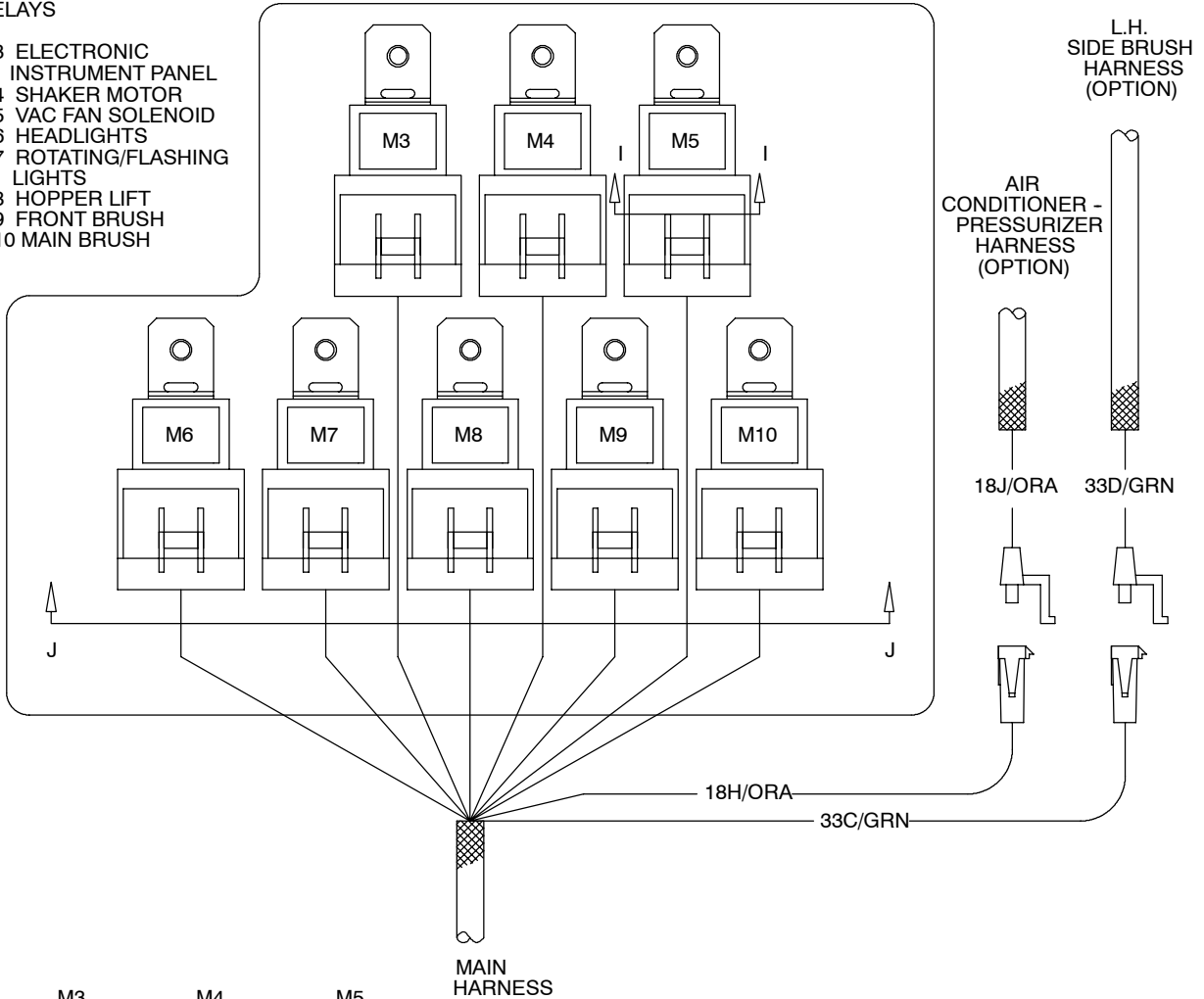

- 85 COIL+
- 86 COIL -
- 30 COMMON CONTACT
- 87 N.O. CONTACT
- 87A N.C. CONTACT

SECTION I-I

VIEW J-J

Wire Harnesses Group 800-810 G/LPG (LSG ENGINE)

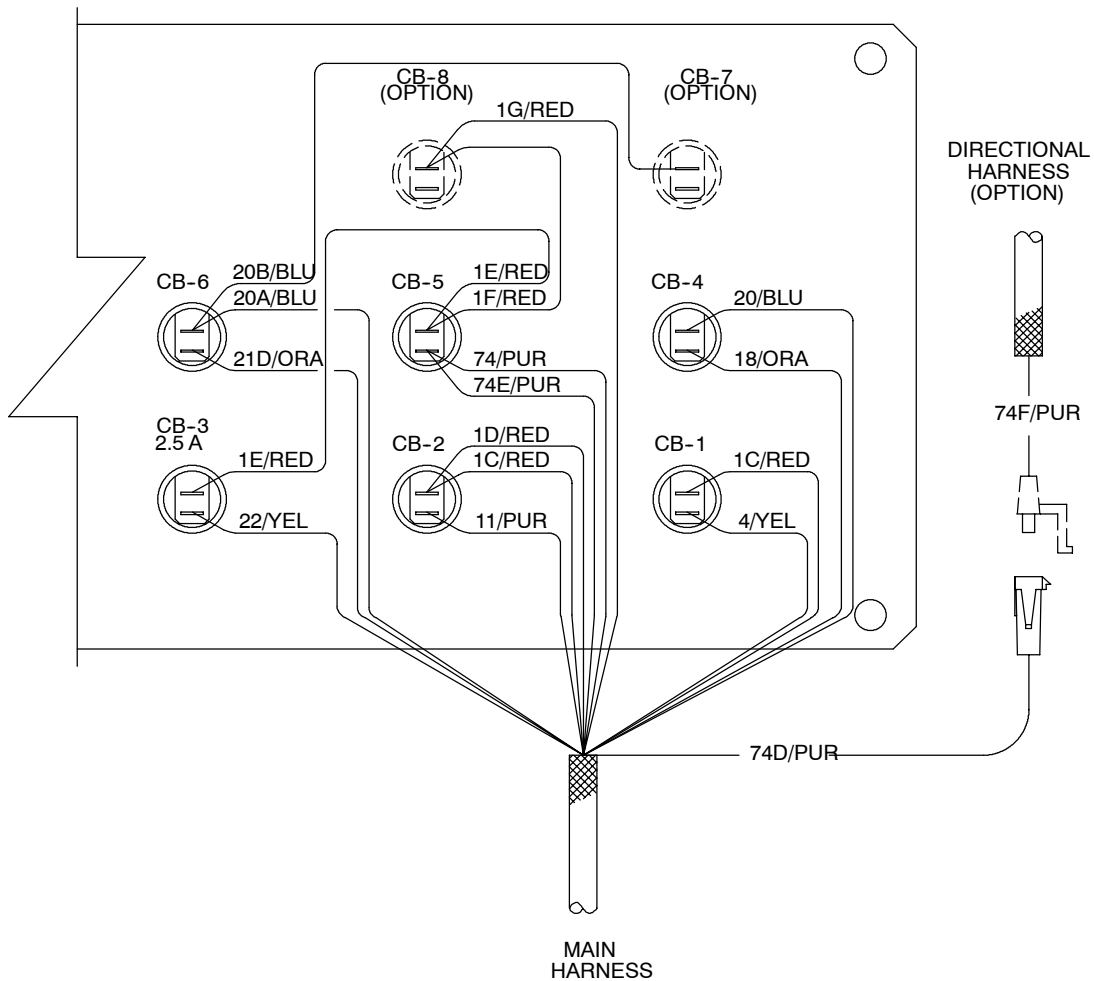

**CIRCUIT
BREAKERS**

- CB-1 HORN
- CB-2 SHAKER MOTOR
- CB-3 VAC FAN RELAY, SHAKER RELAY, WARNING LIGHT & HEADLIGHT
- CB-4 ELECTRONIC INSTRUMENT PANEL
- CB-5 ROTATING LIGHT & BACK-UP ALARM
- CB-6 HOPPER LIFT RELAY, FRONT/MAIN BRUSH
- CB-7 LEFT HAND SIDE BRUSH
- CB-8 CAB ACCESSORIES

Wire Harnesses Group 800-810 G/LPG (LSG ENGINE)

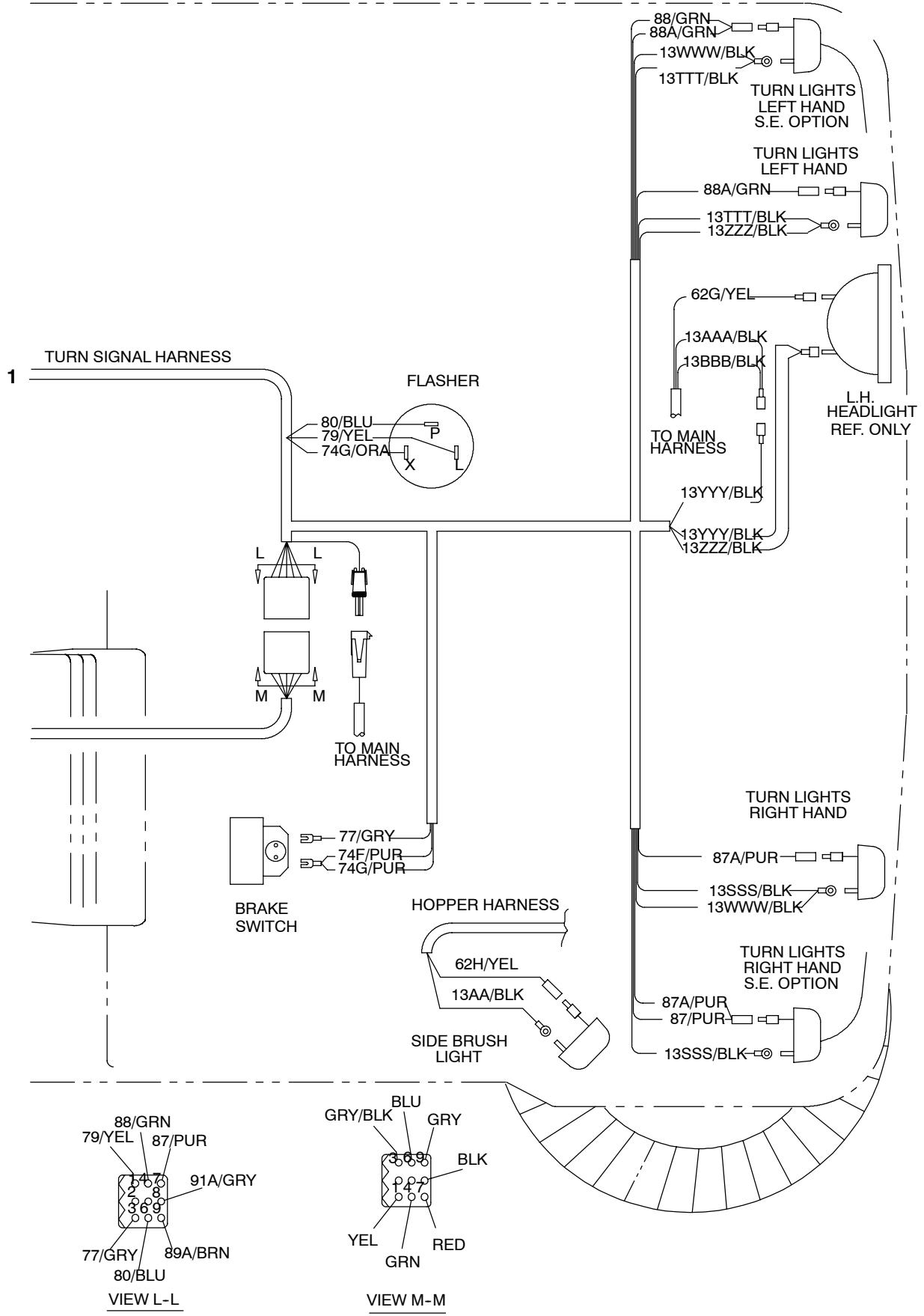

Wire Harnesses Group 800-810 G/LPG (LSG ENGINE)

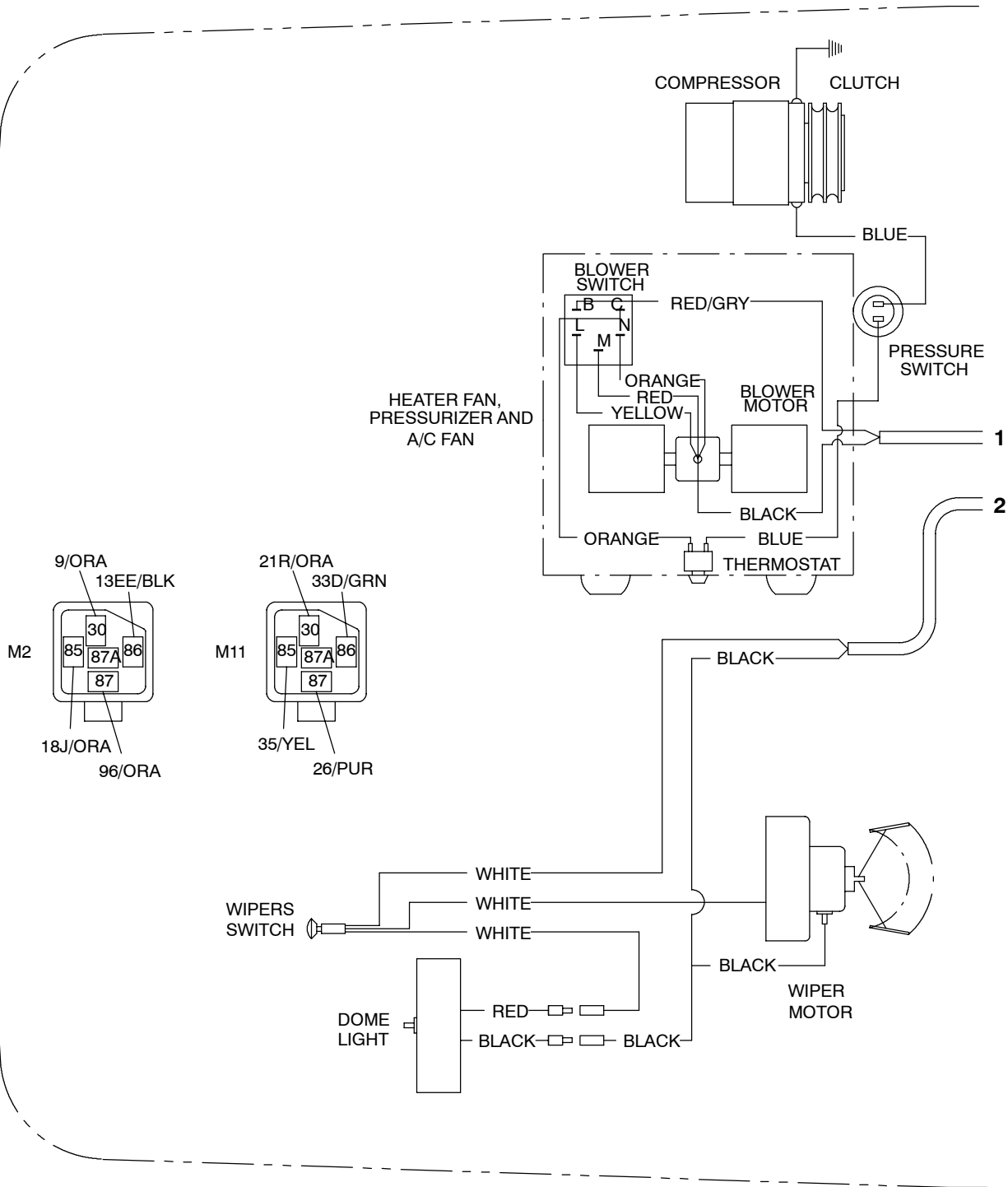

Wire Harnesses Group 800-810 G/LPG (LSG ENGINE)

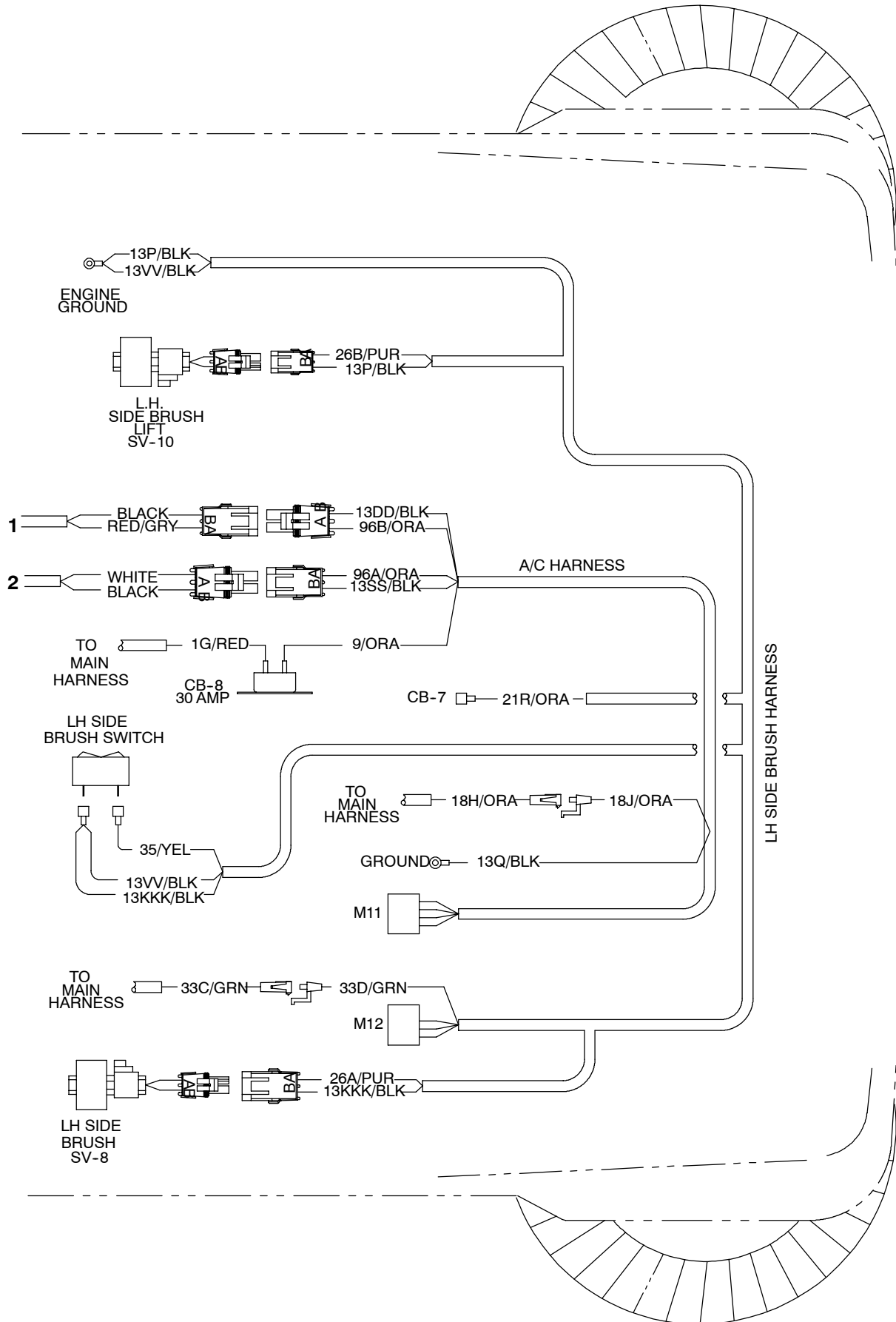

Wire Harnesses Group 800-810 G/LPG (LSG ENGINE)

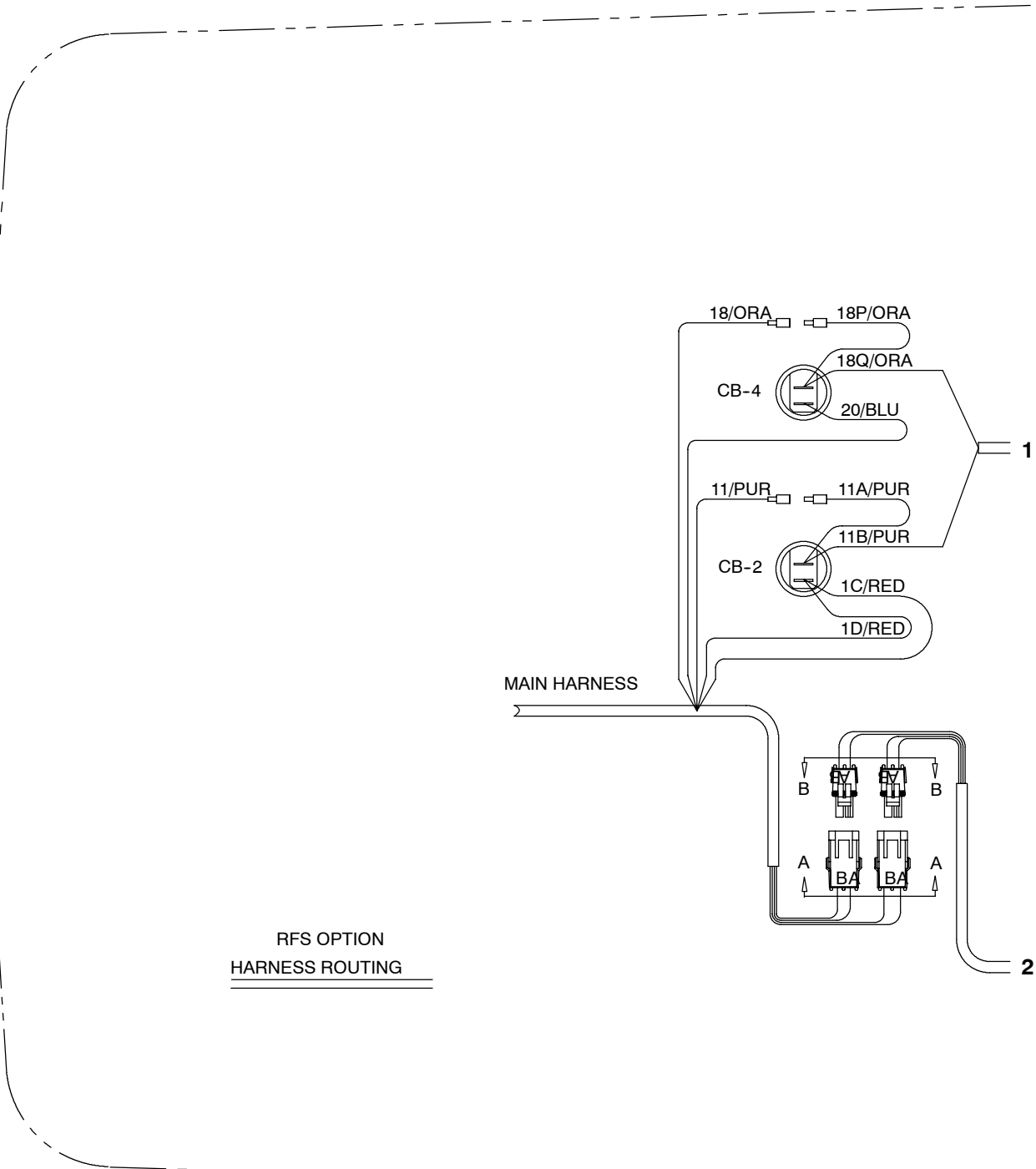

RFS OPTION
HARNESS ROUTING

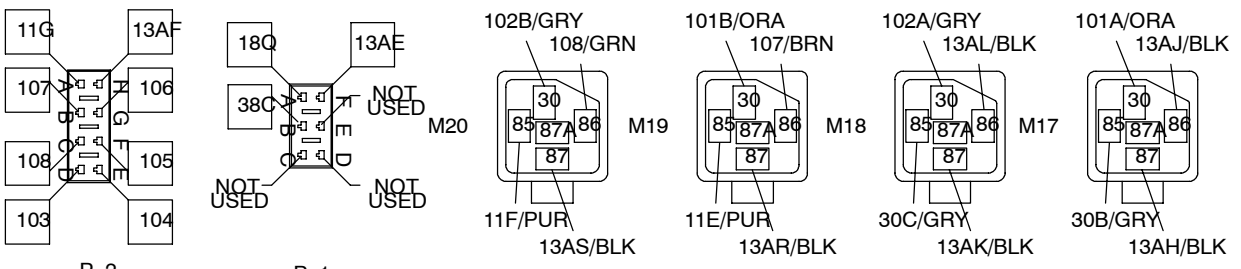

VIEW C-C

Wire Harness Group 800-810 G/LPG (LSG ENGINE)

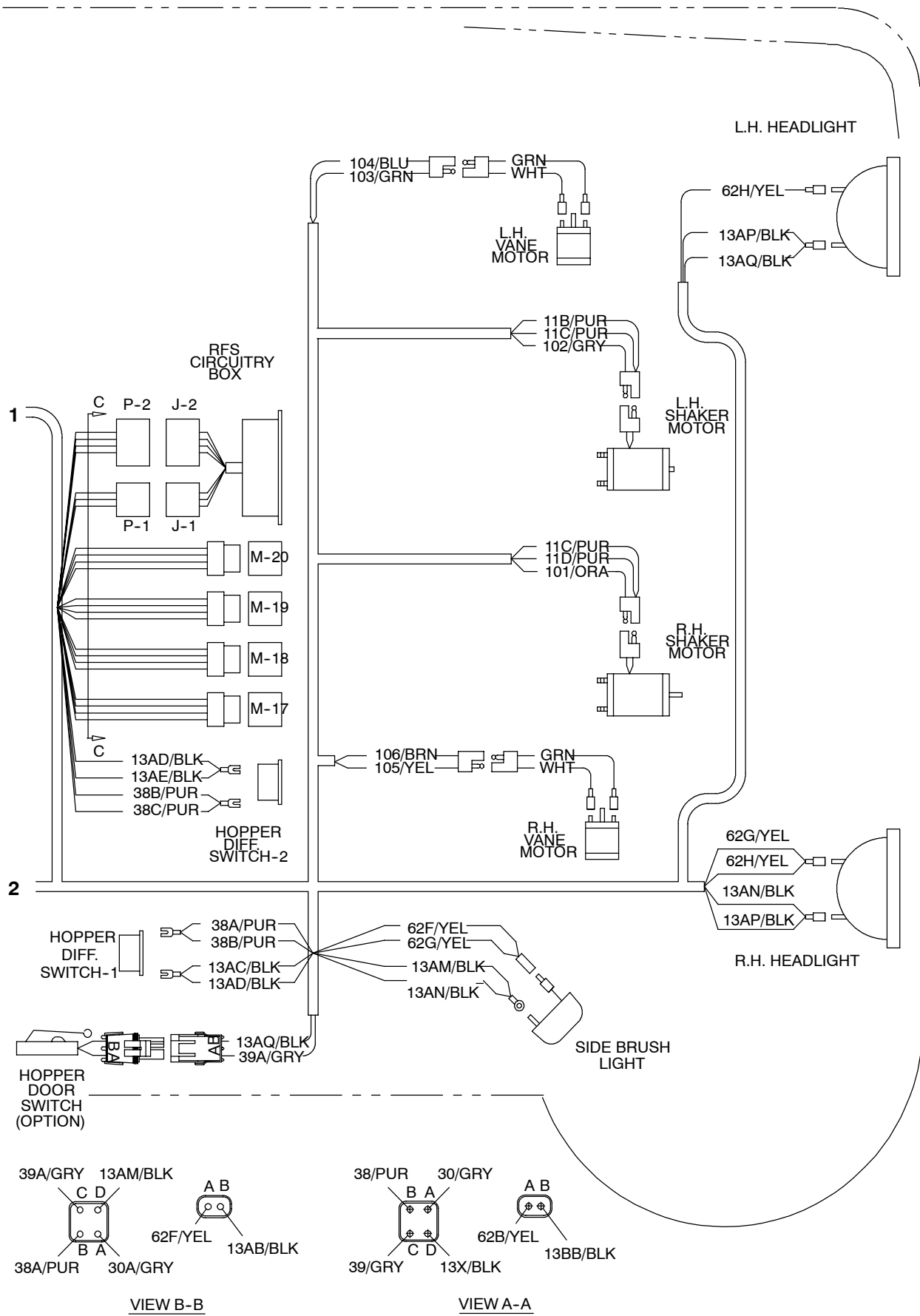

Wire Harnesses Group 800-810 G/LPG (LSG ENGINE)

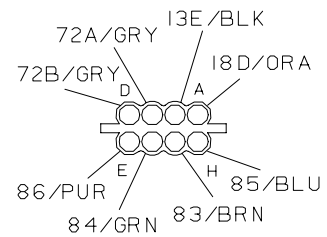
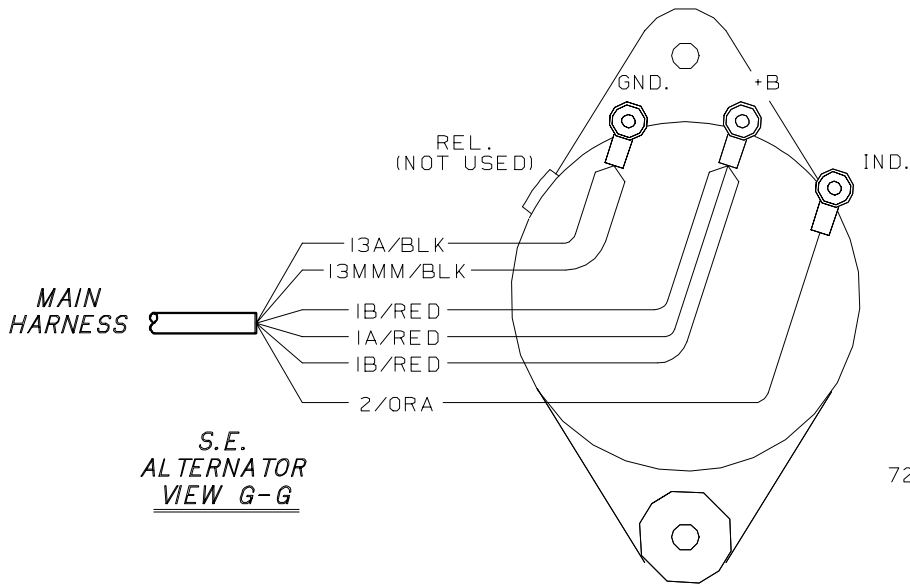
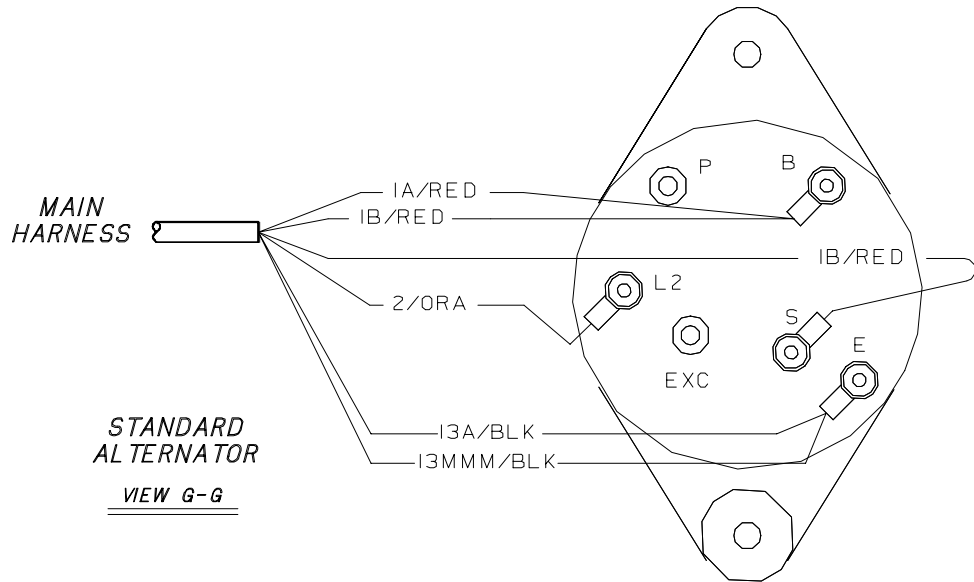

VIEW K-K

GOVERNOR CONTROL

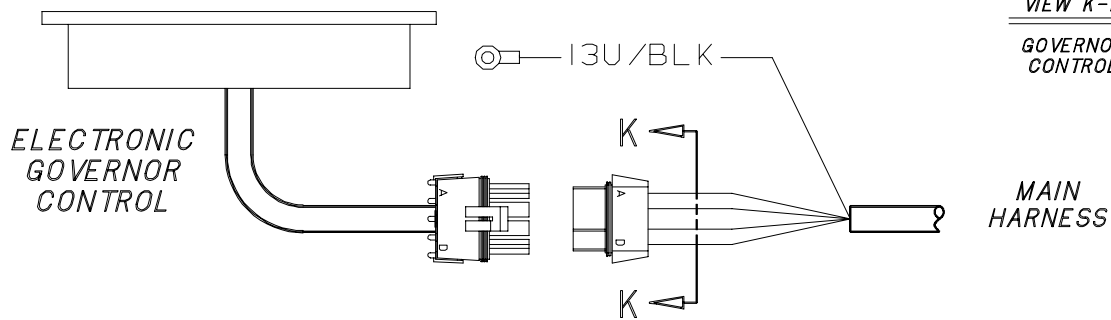

Wire Harnesses Group 800-810 G/LPG (LSG ENGINE)

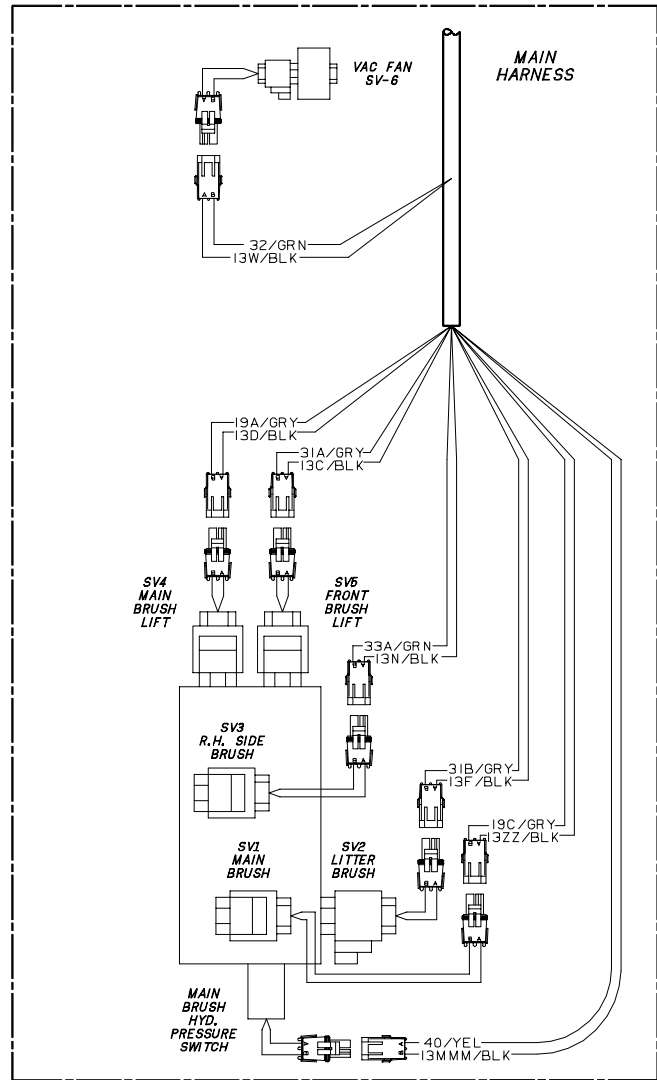
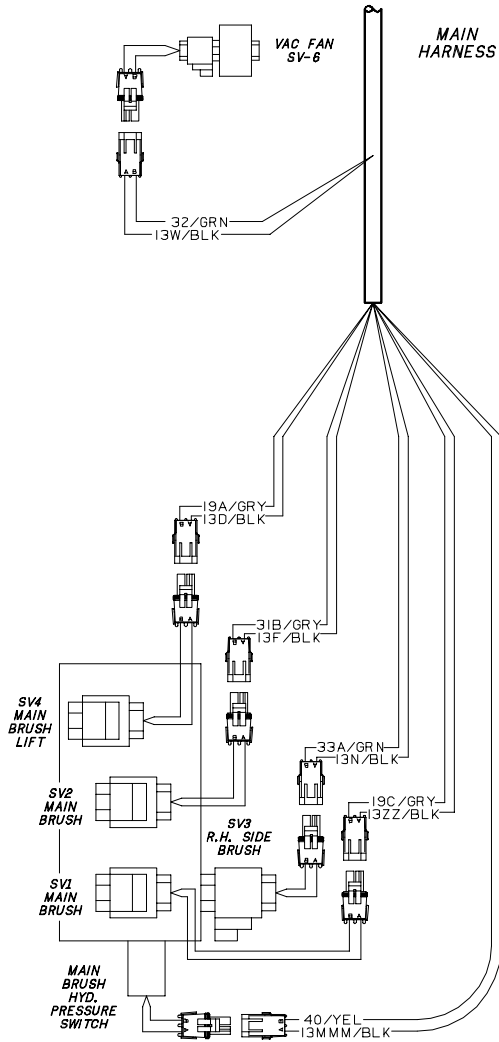

**810
MODEL
ONLY**

Electrical Schematic 800-810 G/LPG (LRG ENGINE)

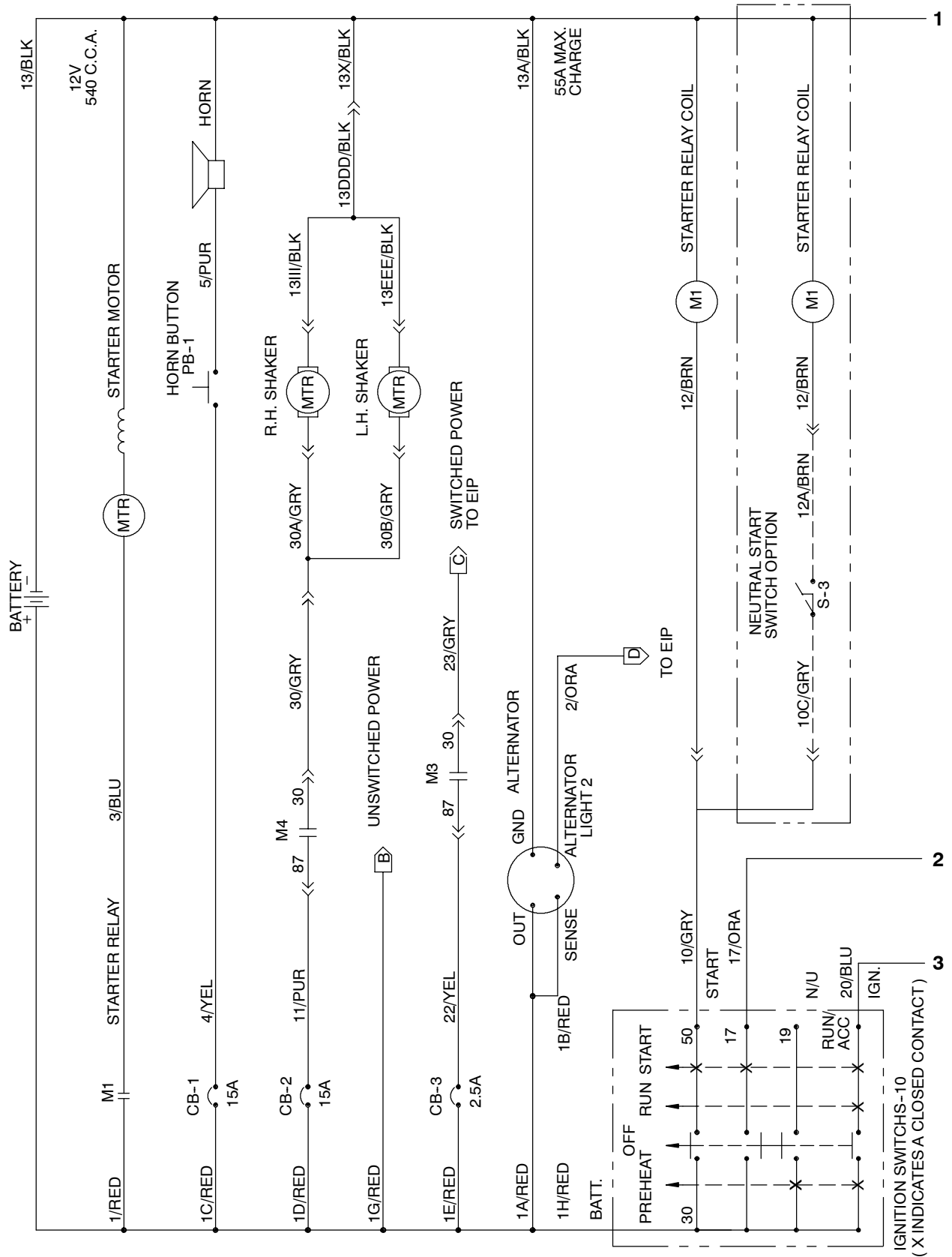

Electrical Schematic 800-810 G/LPG (LRG ENGINE)

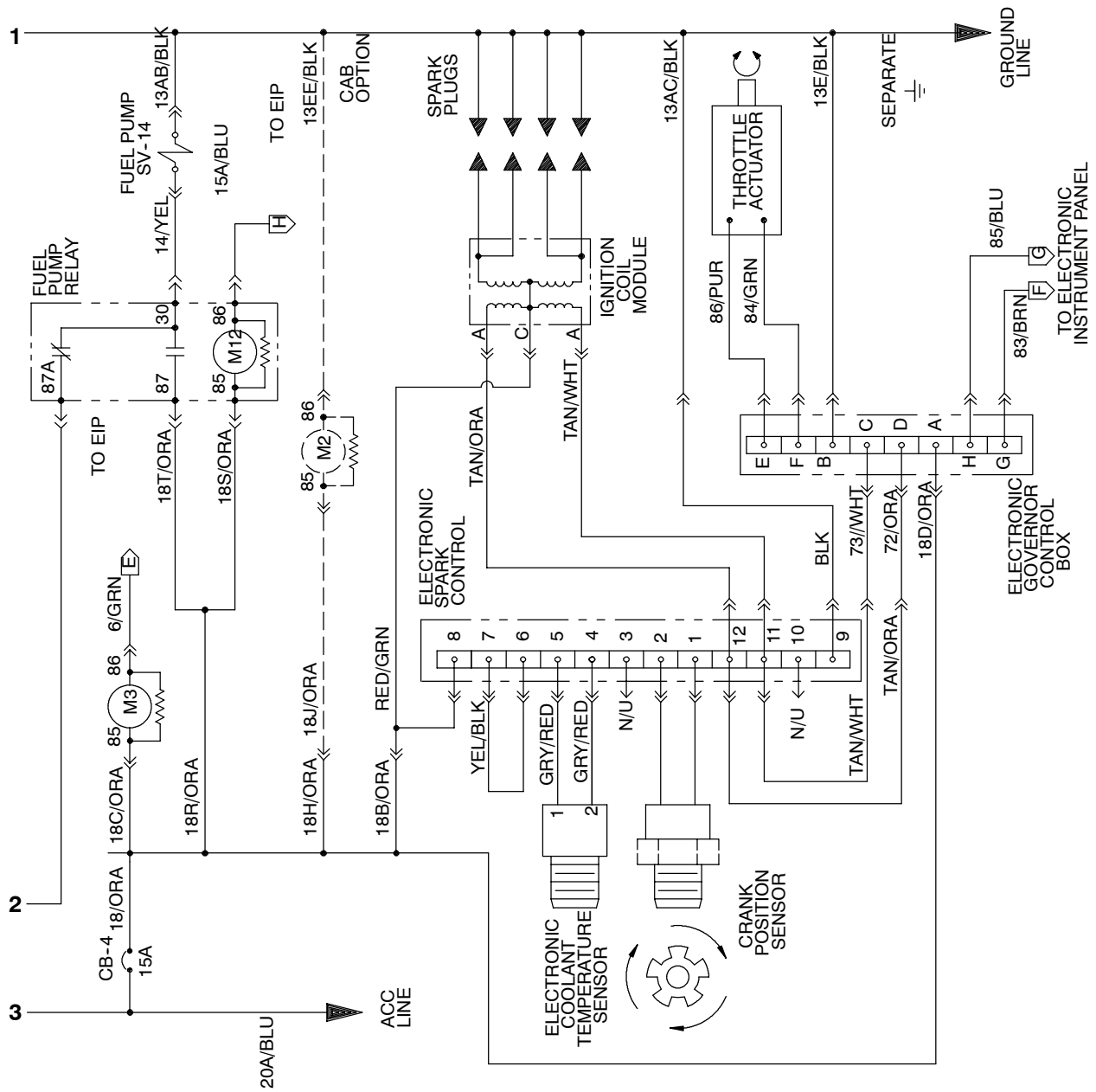

Electrical Schematic 800-810 G/LPG (LRG ENGINE)

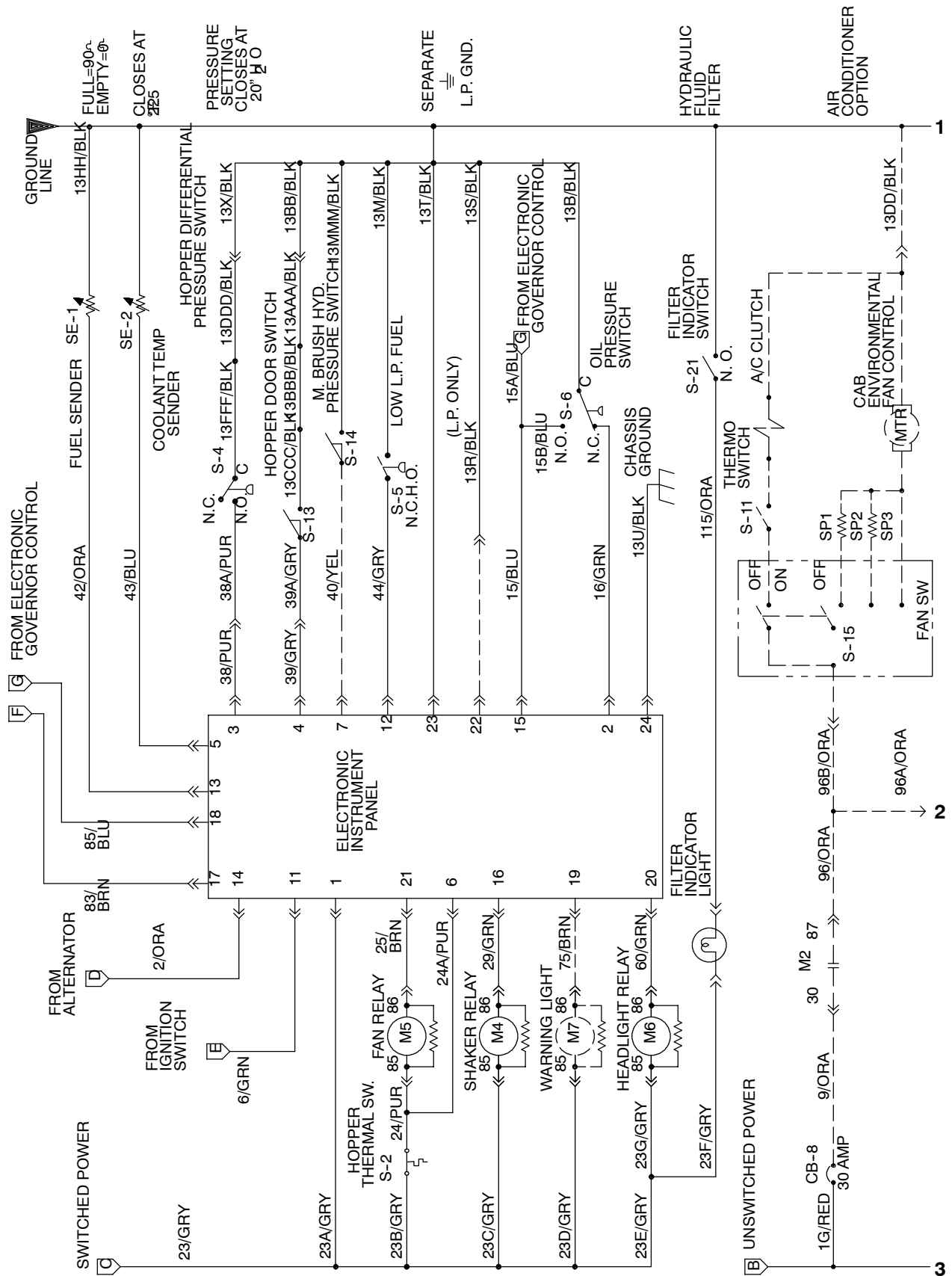

Electrical Schematic 800-810 G/LPG (LRG ENGINE)

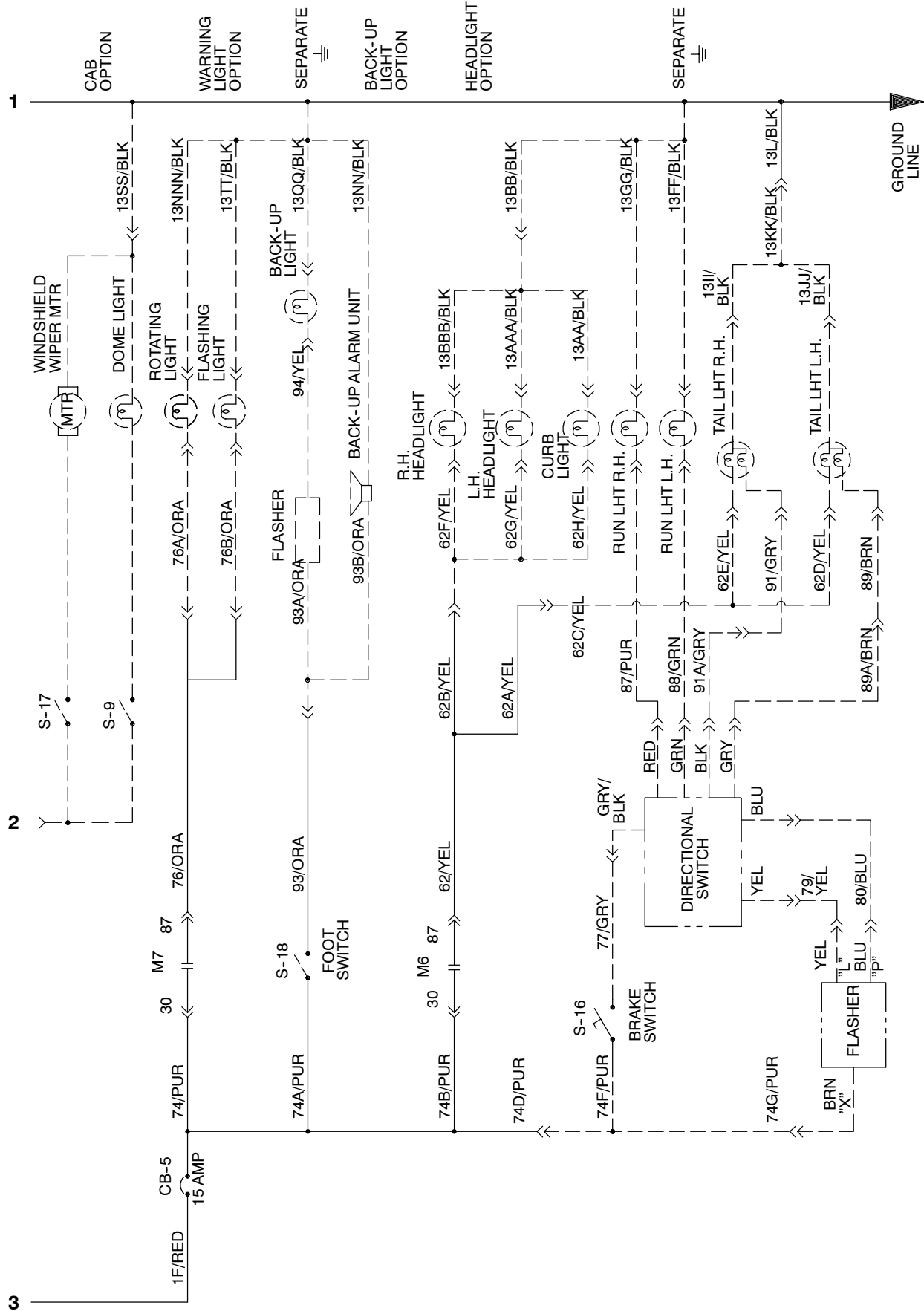

Electrical Schematic 800-810 G/LPG (LRG ENGINE)

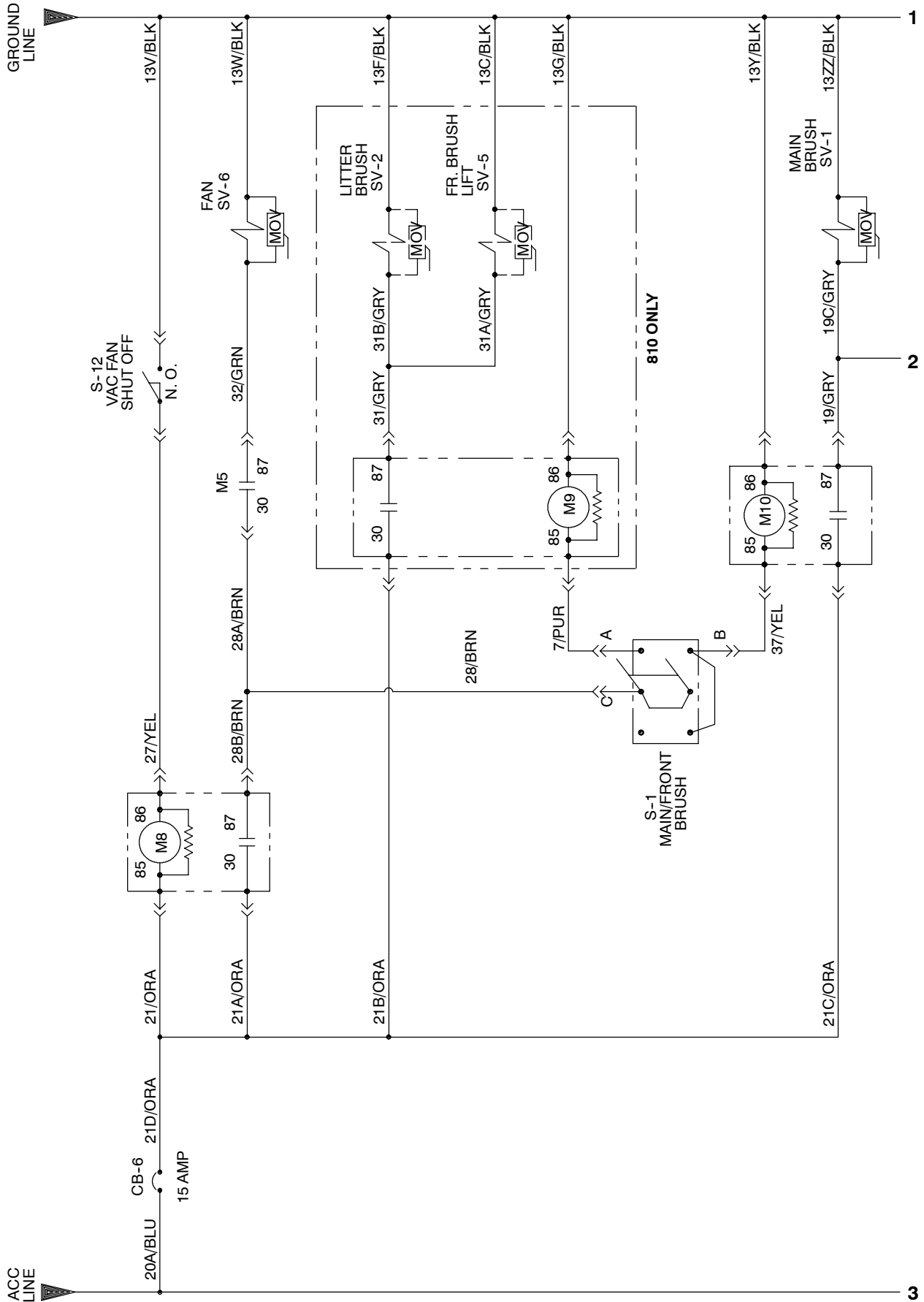

Electrical Schematic 800-810 G/LPG (LRG ENGINE)

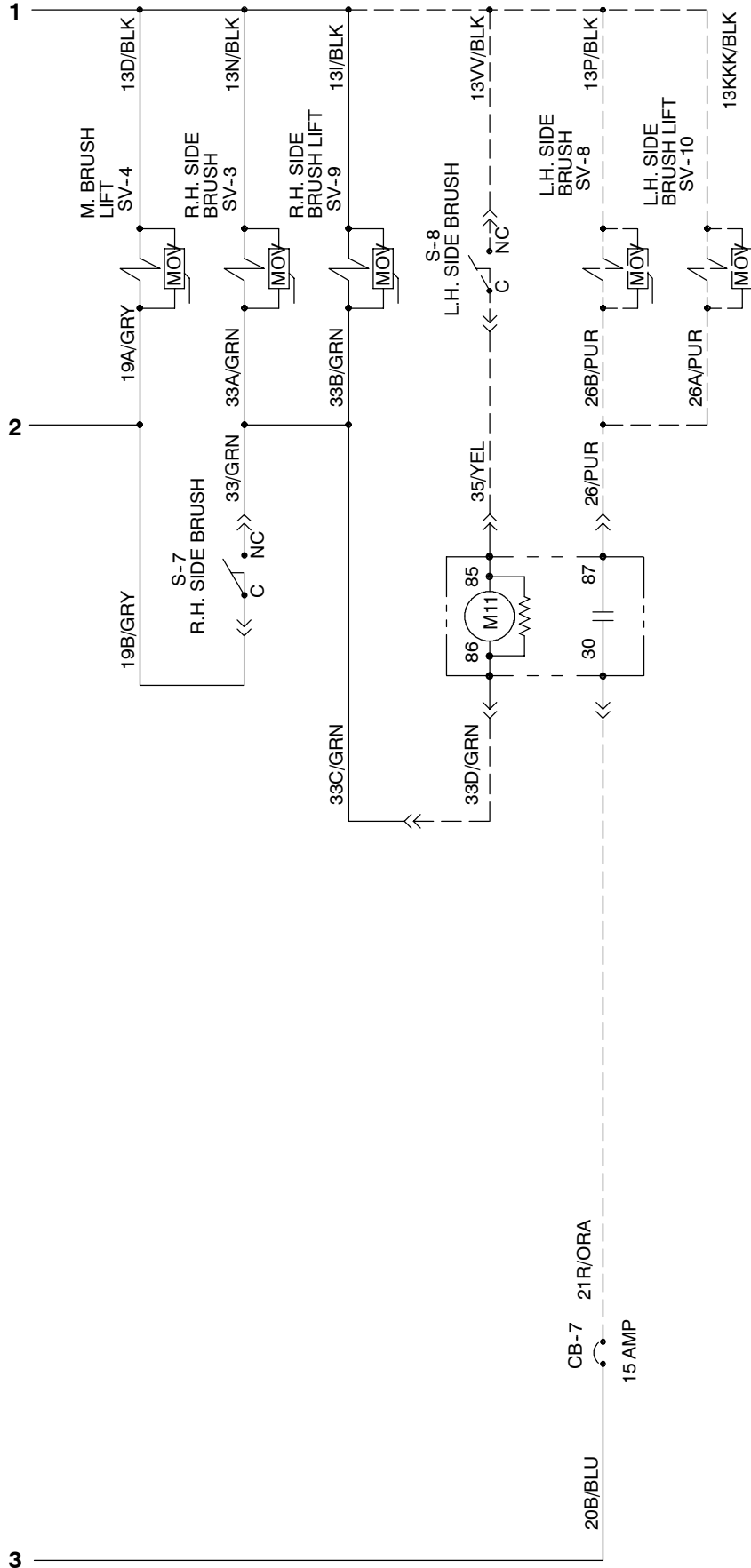

LEGEND	
M	POWER RELAY
HM	HOURMETER
MTR	MOTOR
SV	SOLENOID VALVE
CB	CIRCUIT BREAKER
S	SWITCH
PM	PERMANENT MAGNET
ACC	ACCESSORY
J	JACK-FEM. SOCKET
GND	GROUND CHASSIS
P	PLUG-MALE PIN
C	COMMON
PB	PUSHBUTTON
N.O.	NORMALLY OPEN
VM	VOLTMETER
N.C.	NORMALLY CLOSED
FU	FUSE
NOV	METAL OXIDE VARISTOR

Electrical Schematic 800-810 G/LPG (LRG ENGINE)

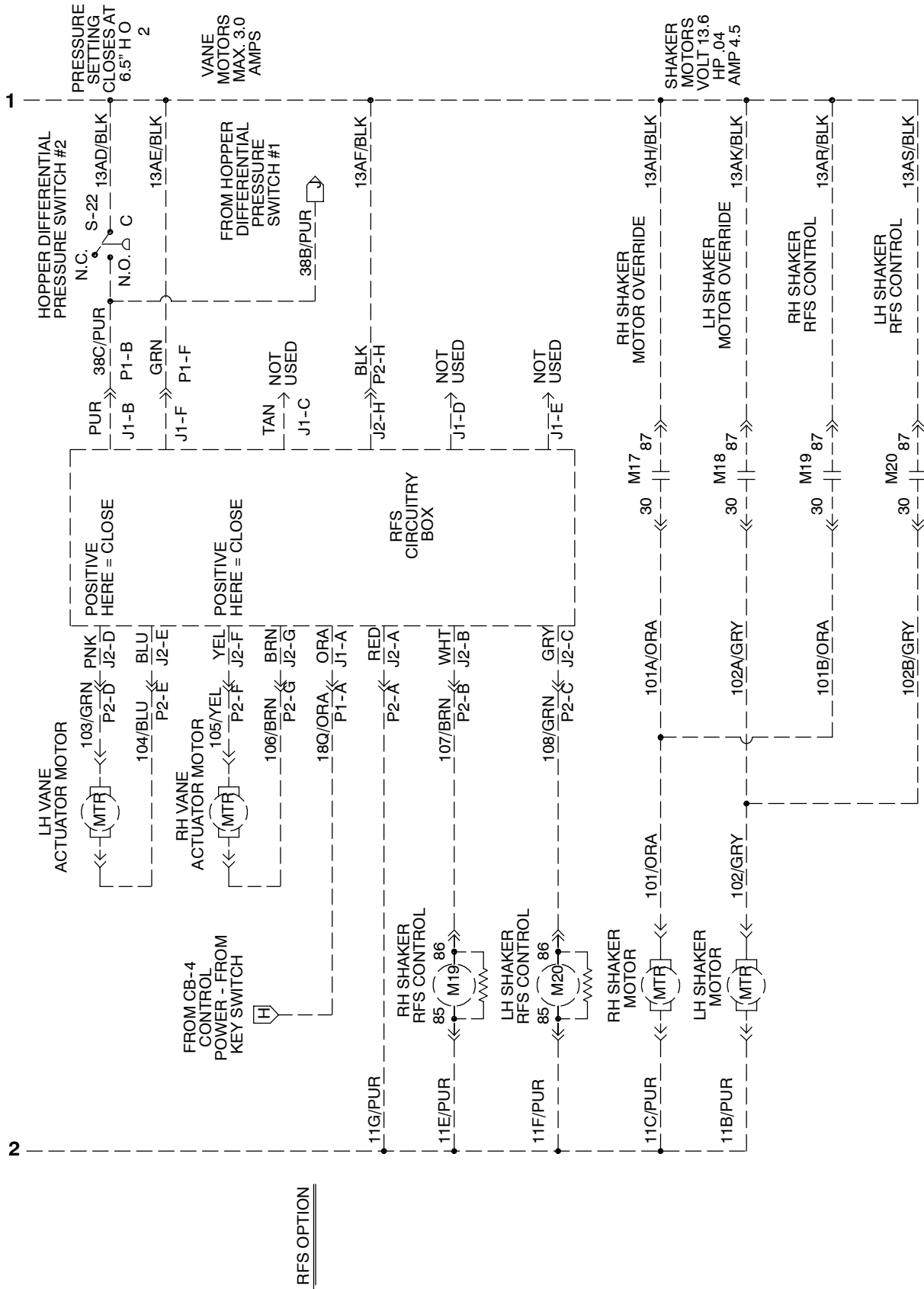

Wire Harnesses Group 800-810 G/LPG (LRG ENGINE)

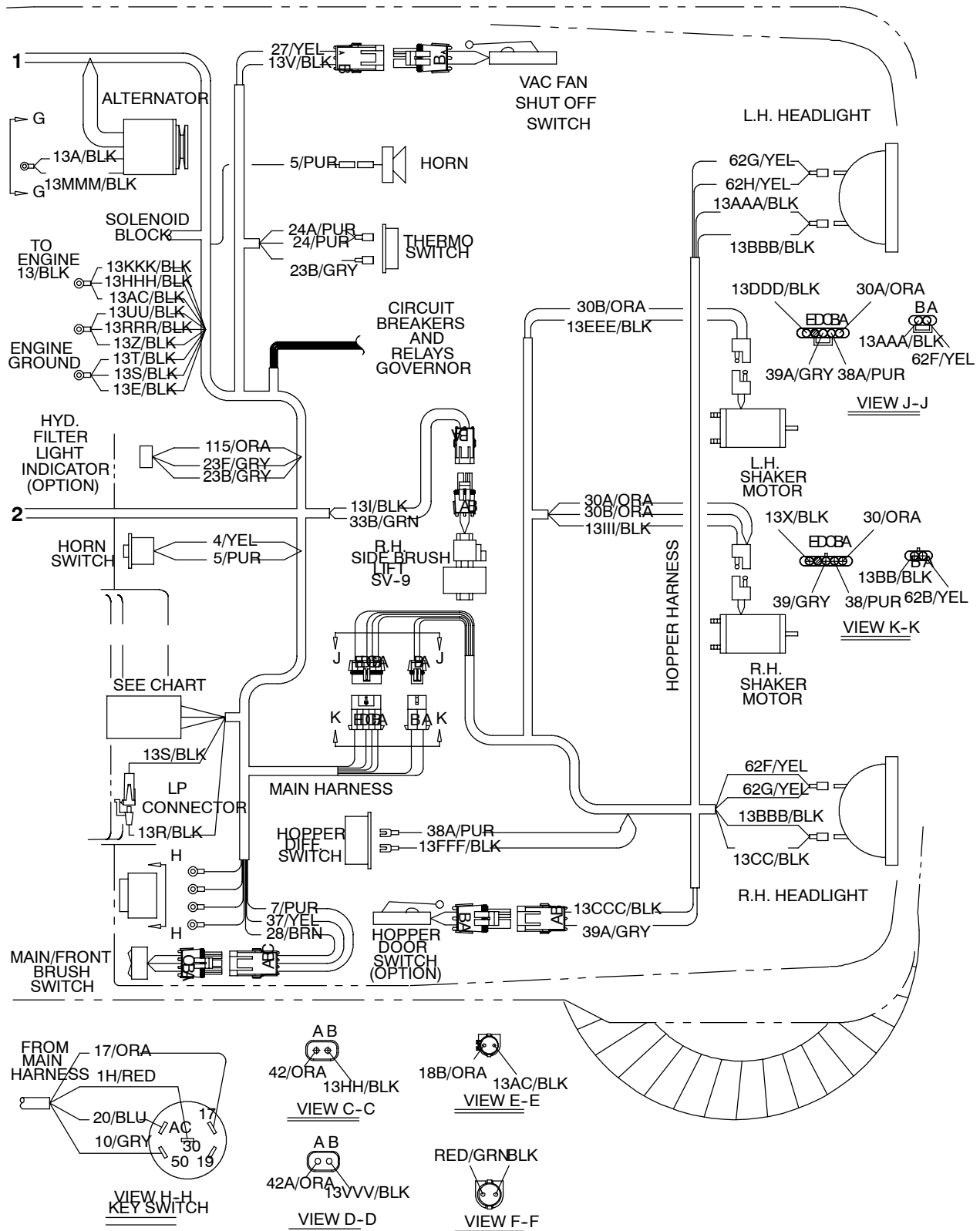

Wire Harnesses Group 800-810 G/LPG (LRG ENGINE)

RELAYS

- M3 ELECTRONIC INSTRUMENT PANEL
- M4 SHAKER MOTOR
- M5 VAC FAN SOLENOID
- M6 HEADLIGHTS
- M7 ROTATING/FLASHING LIGHTS
- M8 HOPPER LIFT
- M9 FRONT BRUSH
- M10 MAIN BRUSH
- M12 FUEL PUMP

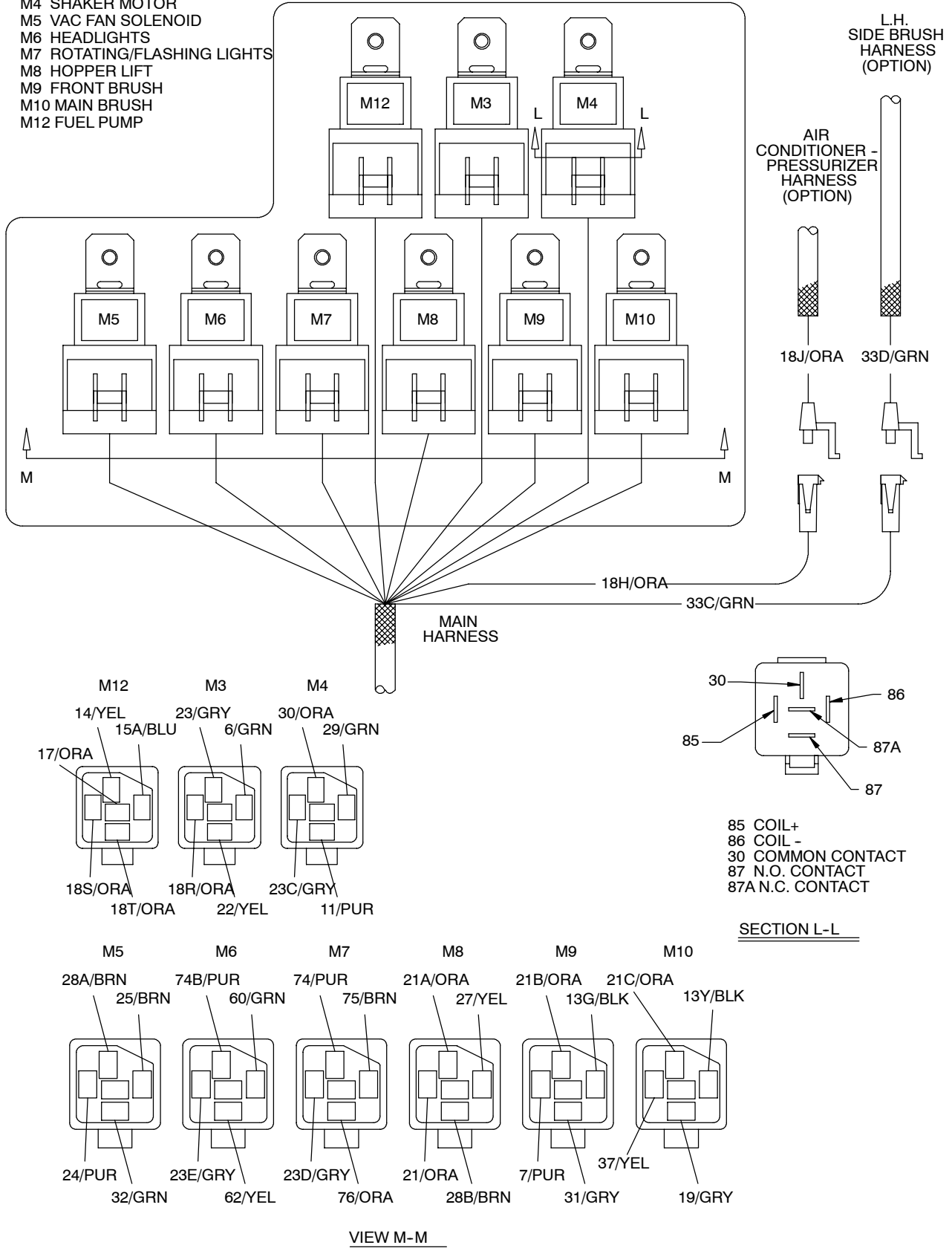

Wire Harnesses Group 800-810 G/LPG (LRG ENGINE)

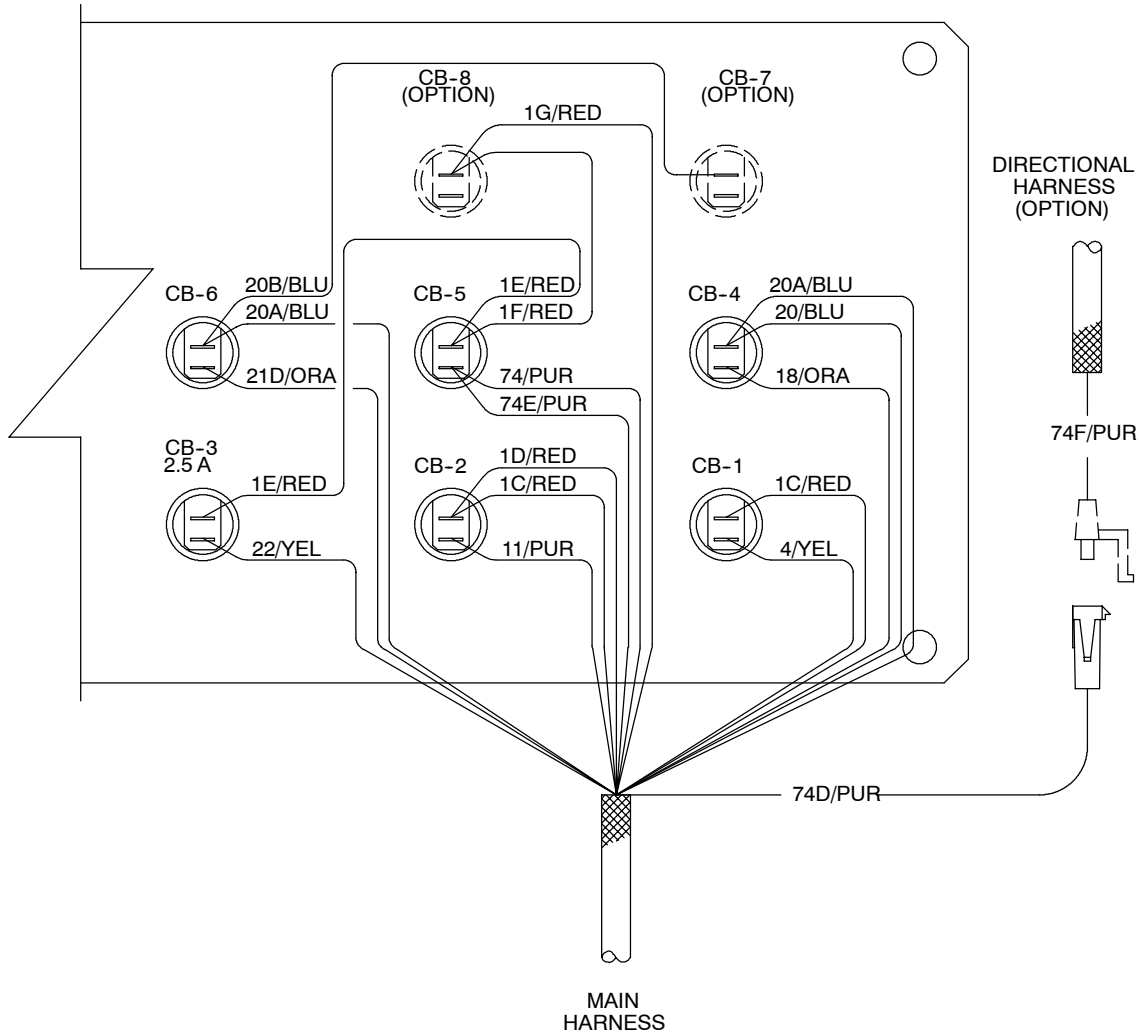

**CIRCUIT
BREAKERS**

- CB-1 HORN
- CB-2 SHAKER MOTOR
- CB-3 VAC FAN RELAY, SHAKER RELAY, WARNING LIGHT & HEADLIGHT
- CB-4 ELECTRONIC INSTRUMENT PANEL
- CB-5 ROTATING LIGHT & BACK-UP ALARM
- CB-6 HOPPER LIFT RELAY, FRONT/MAIN BRUSH
- CB-7 LEFT HAND SIDE BRUSH
- CB-8 CAB ACCESSORIES

Wire Harnesses Group 800-810 G/LPG (LRG ENGINE)

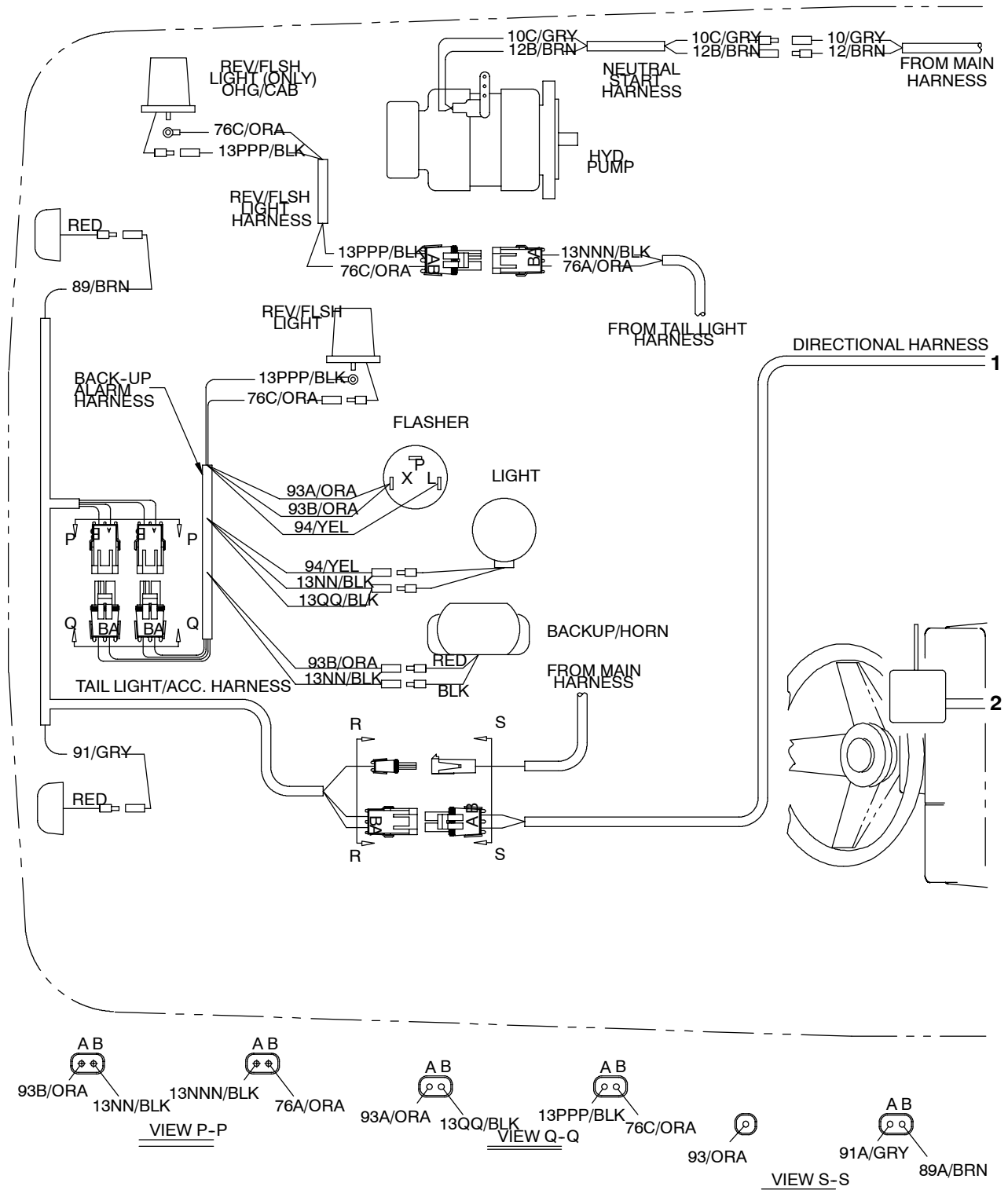

Wire Harnesses Group 800-810 G/LPG (LRG ENGINE)

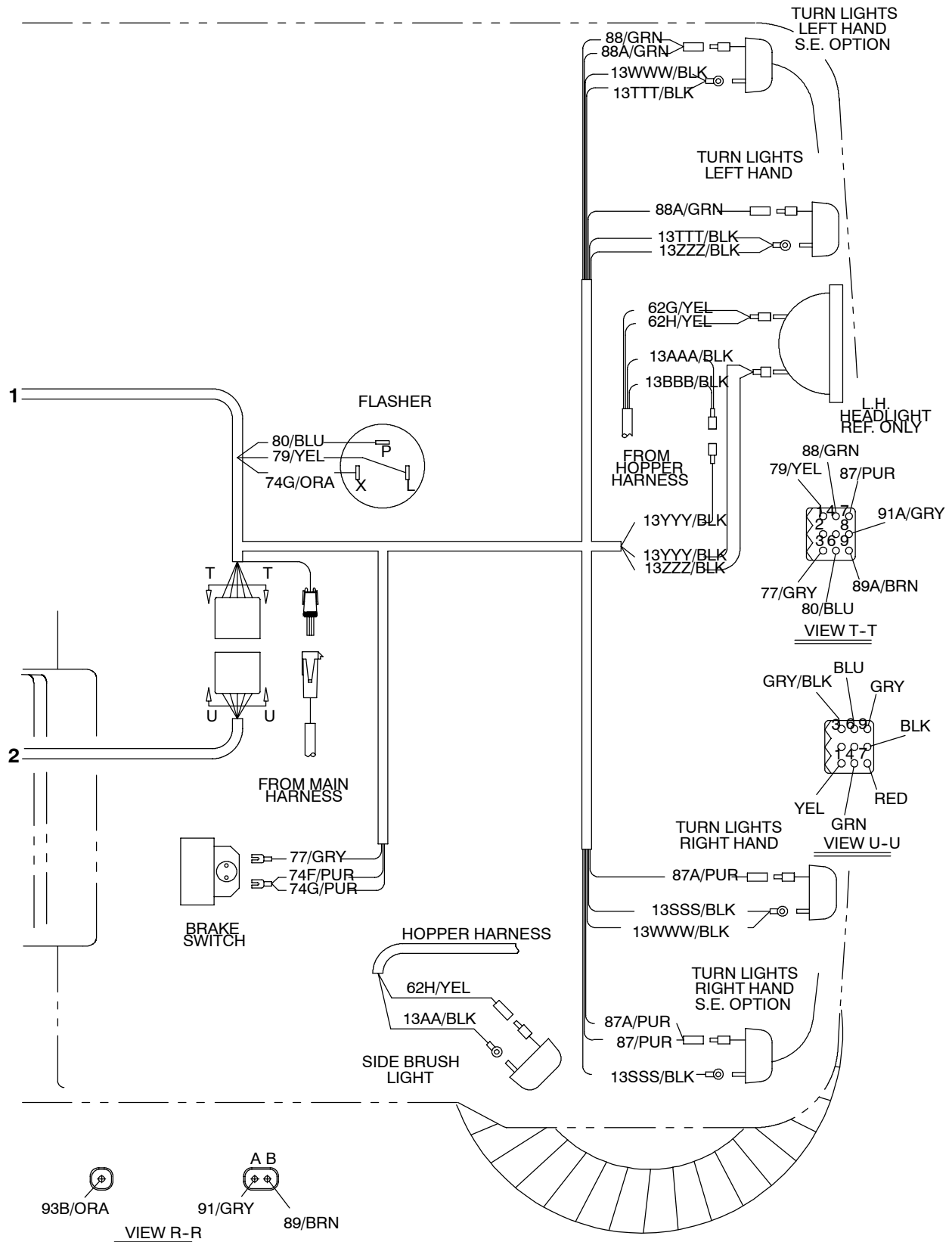

Wire Harness Group 800-810 G/LPG (LRG ENGINE)

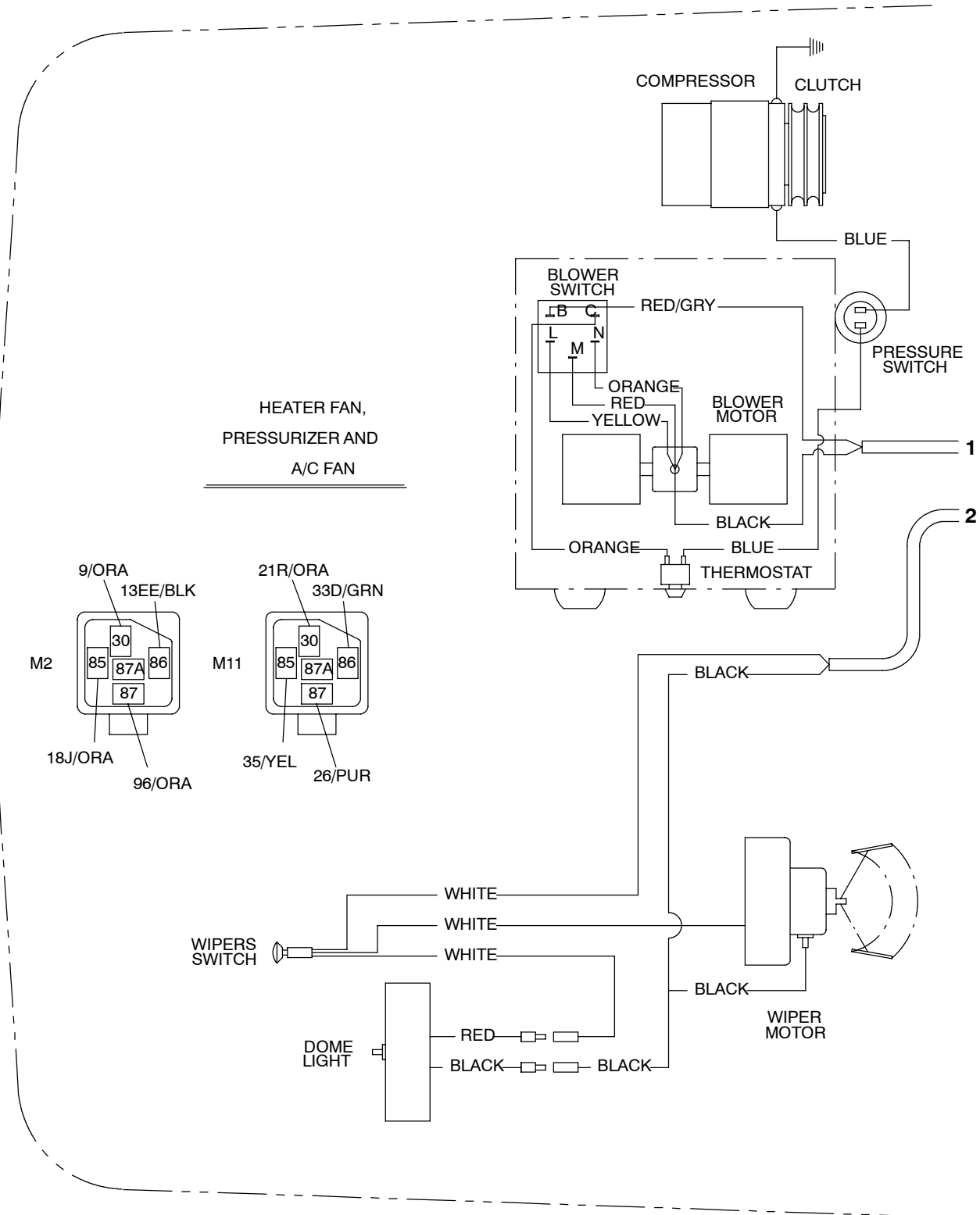

Wire Harnesses Group 800-810 G/LPG (LRG ENGINE)

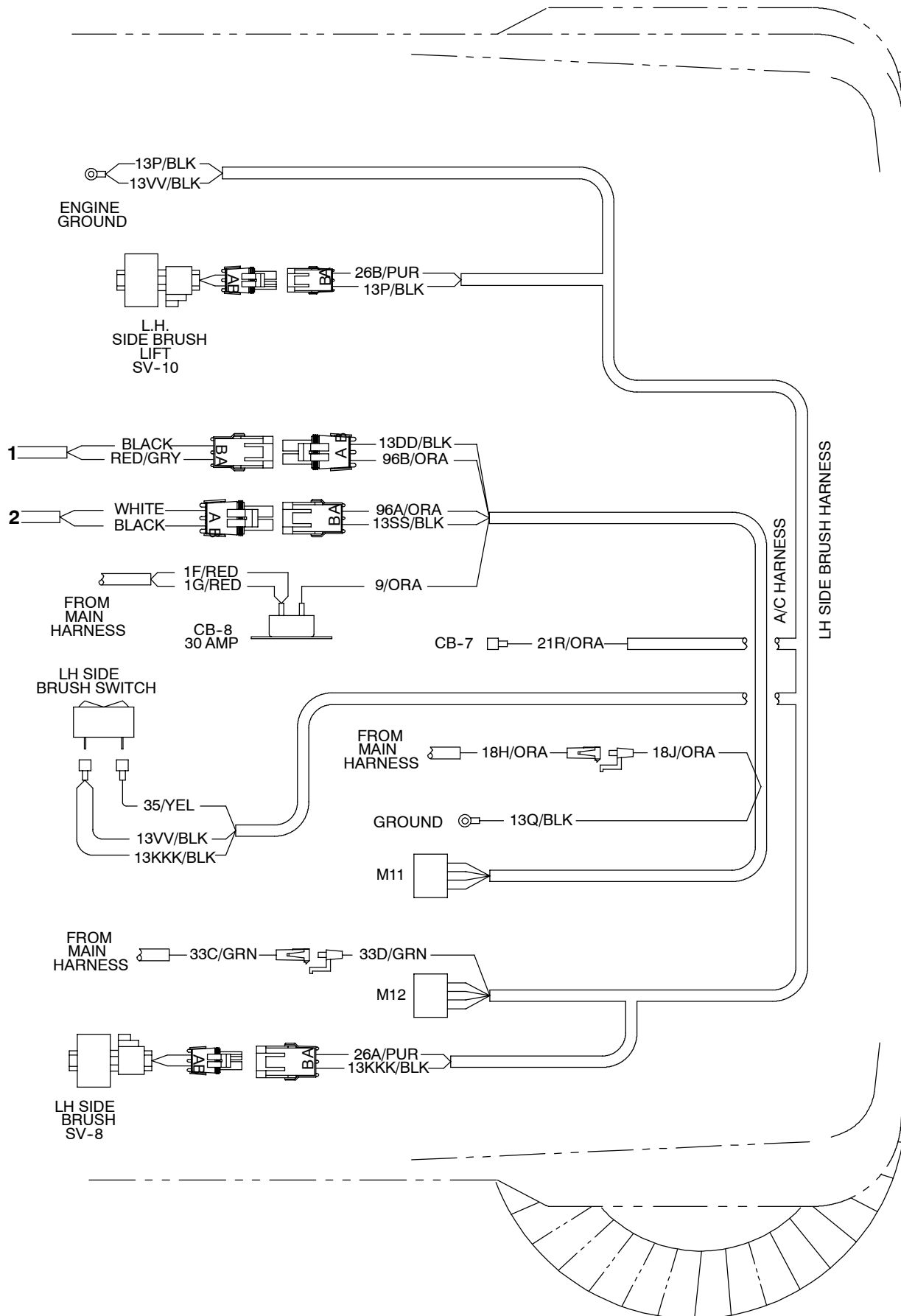

Wire Harnesses Group 800-810 G/LPG (LRG ENGINE)

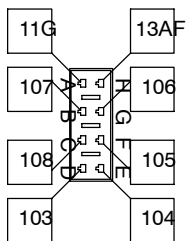
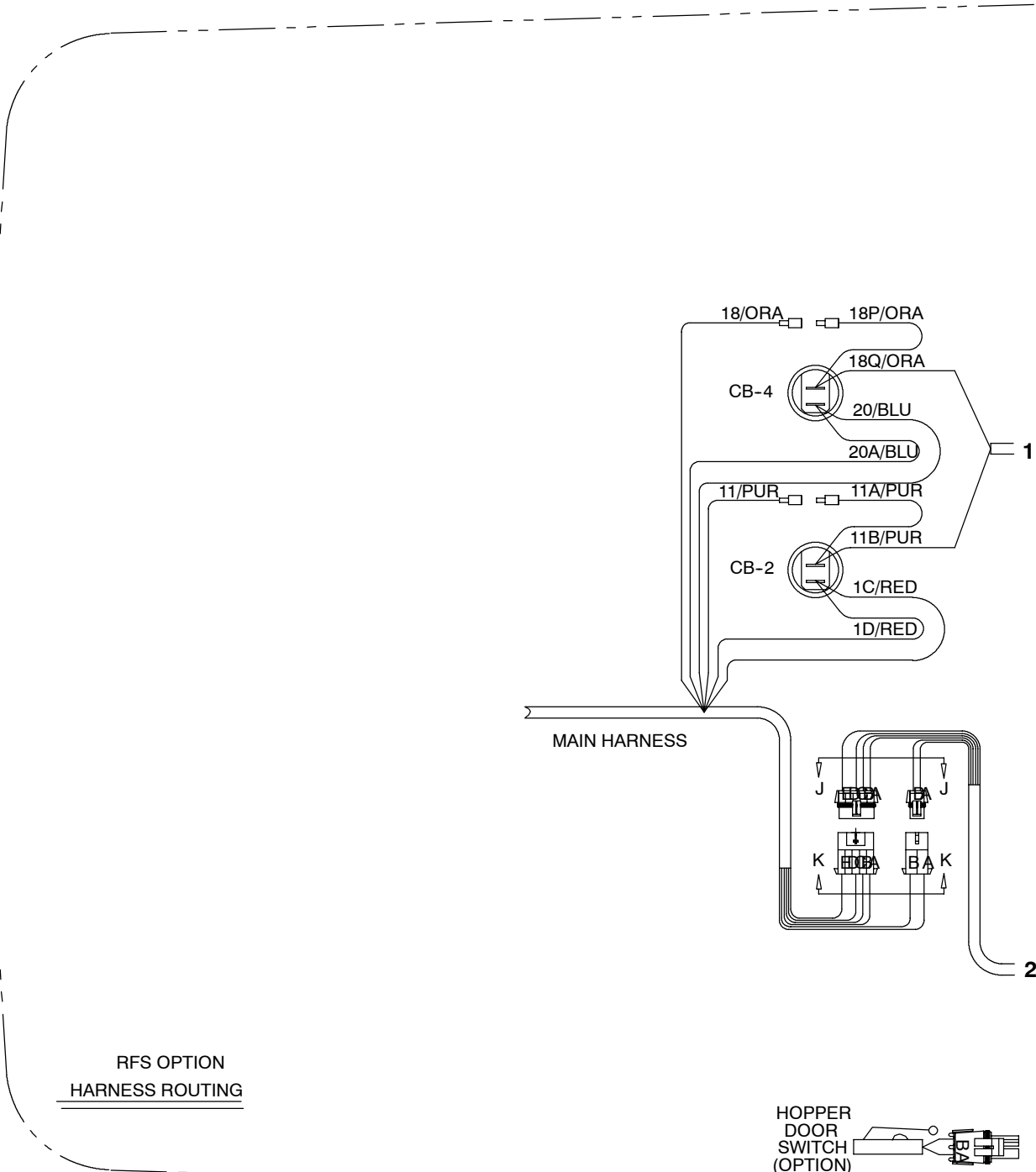

P-2

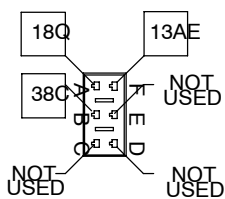

P-1

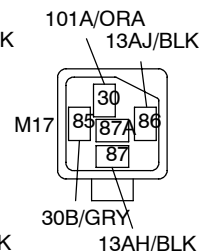
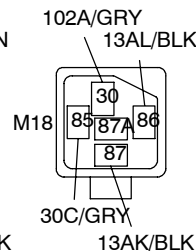
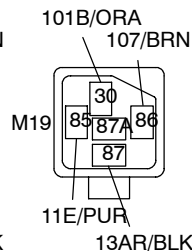
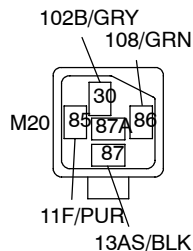

VIEW V-V

Wire Harnesses Group 800-810 G/LPG (LRG ENGINE)

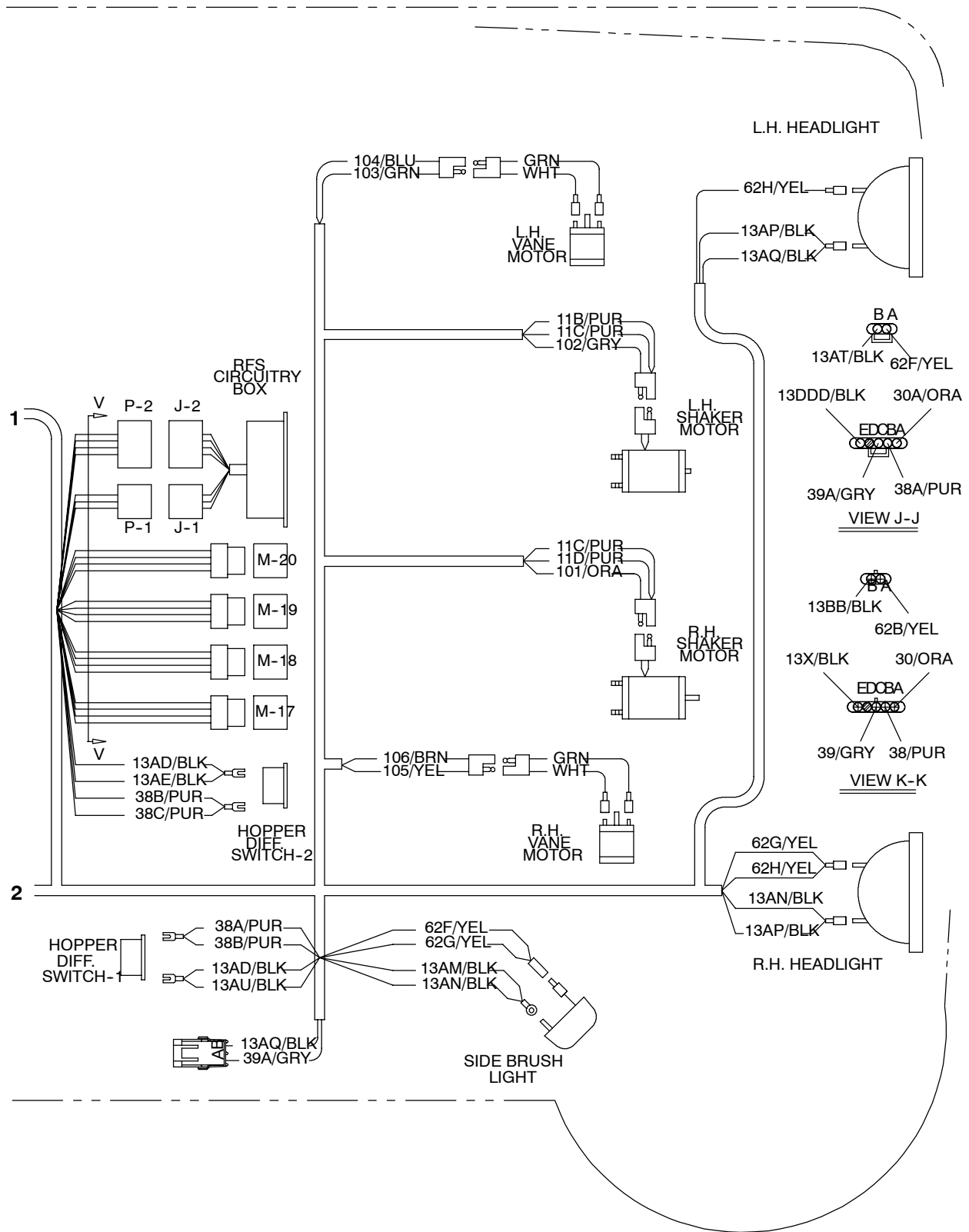

Wire Harnesses Group 800-810 G/LPG (LRG ENGINE)

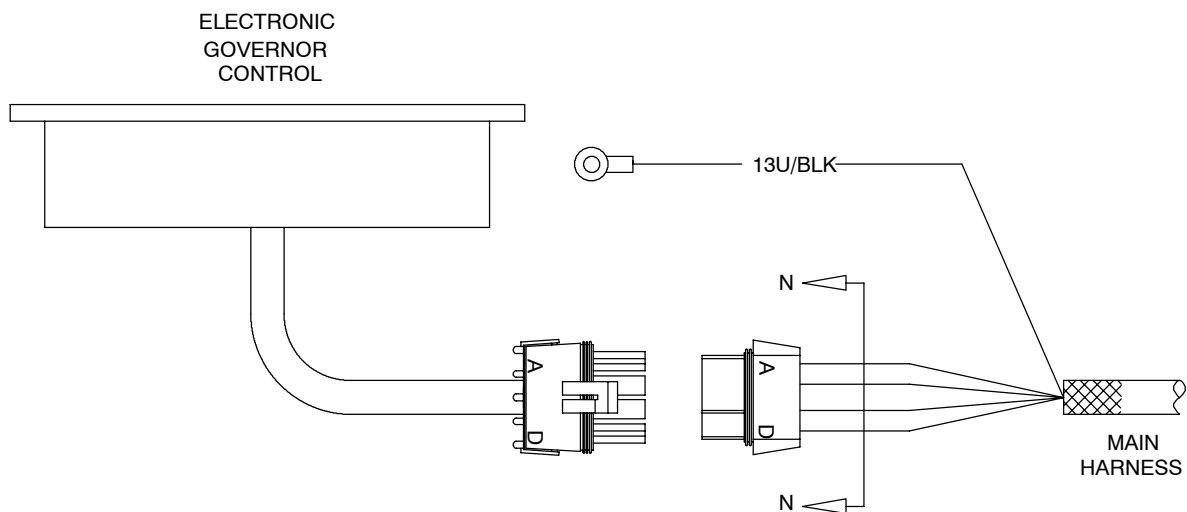
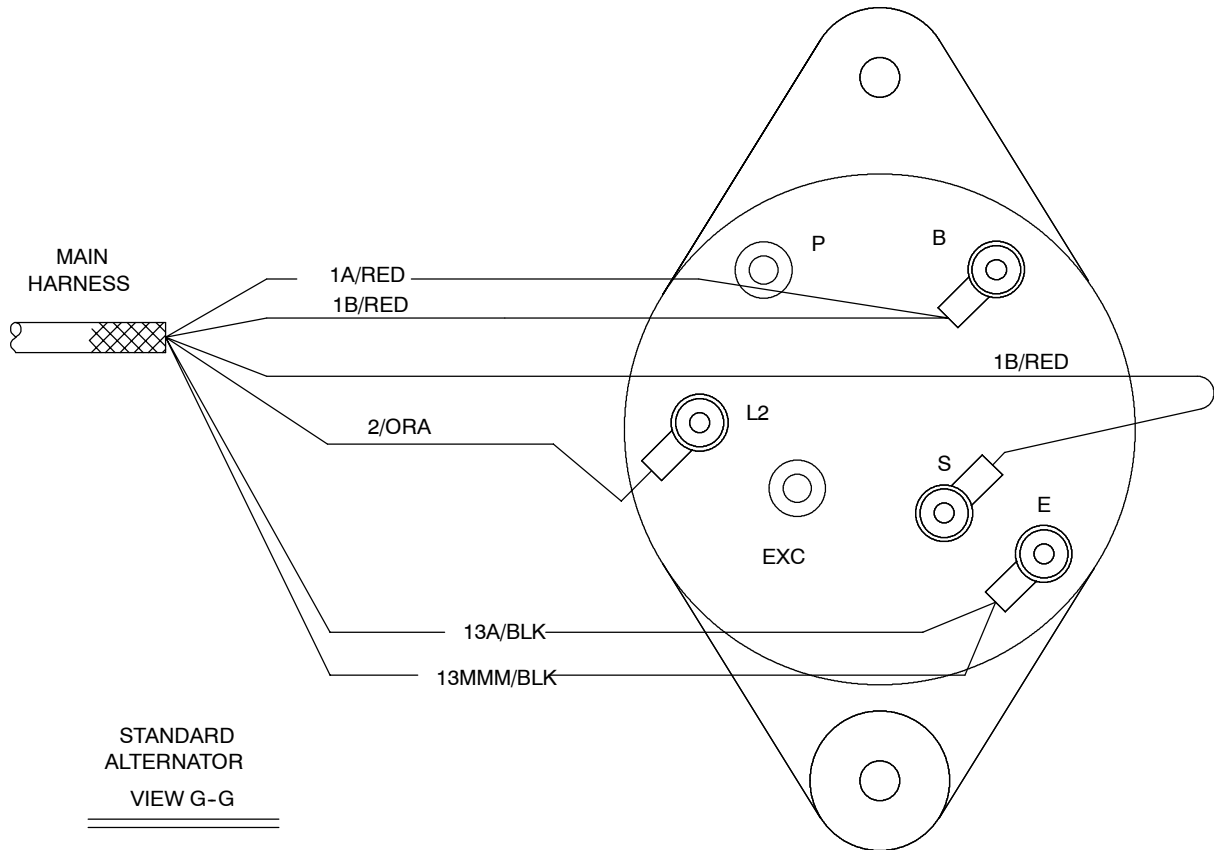

Wire Harnesses Group 800-810 G/LPG (LRG ENGINE)

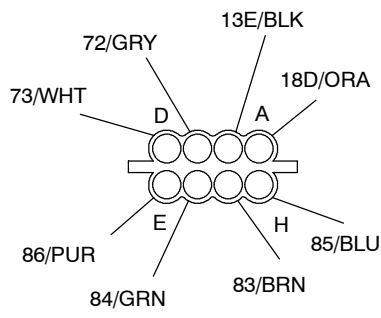
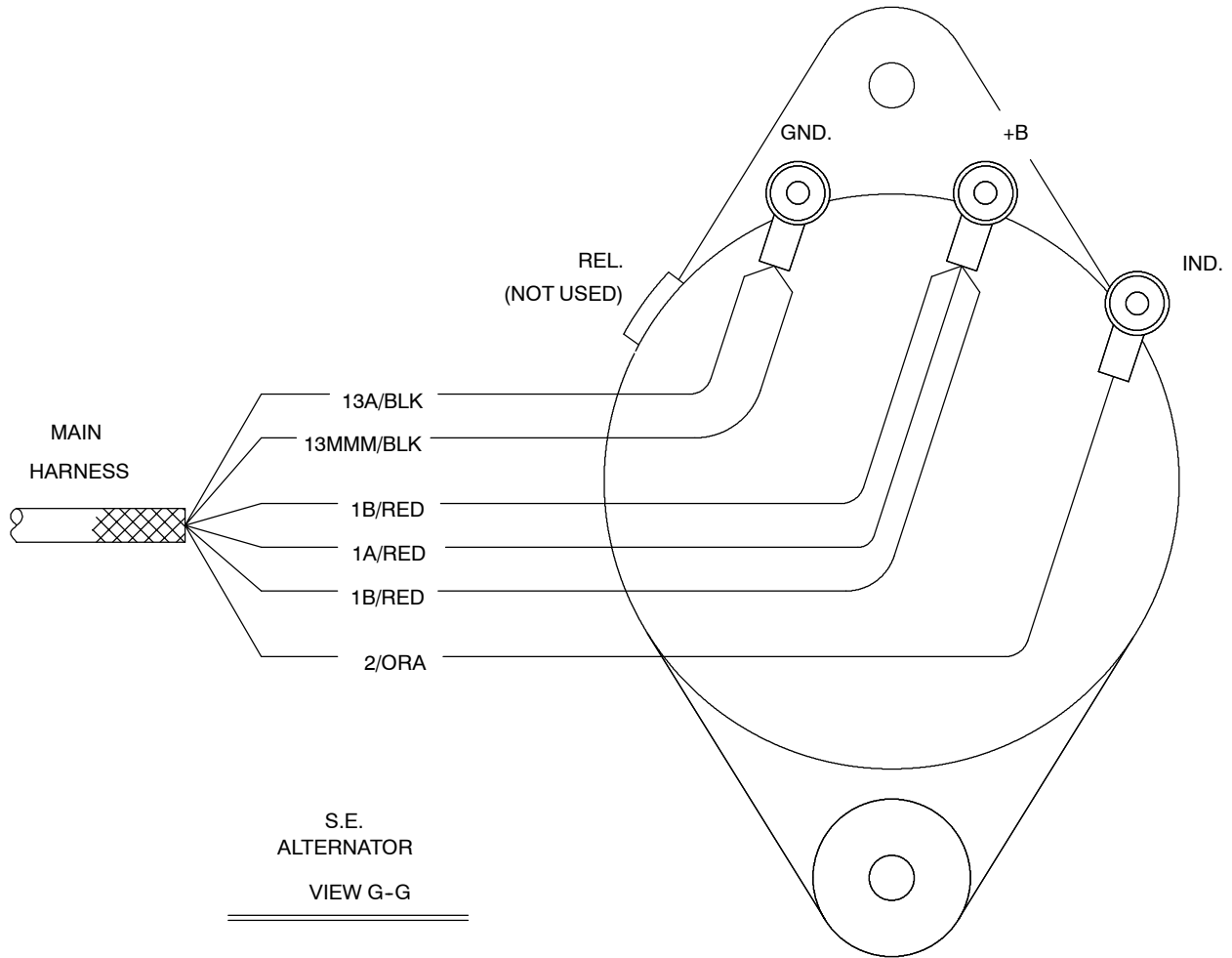

VIEW N-N
ELECTRONIC
GOVERNOR
CONTROL

Electrical Schematic 800-810 D (PERKINS 200 SERIES ENGINE)

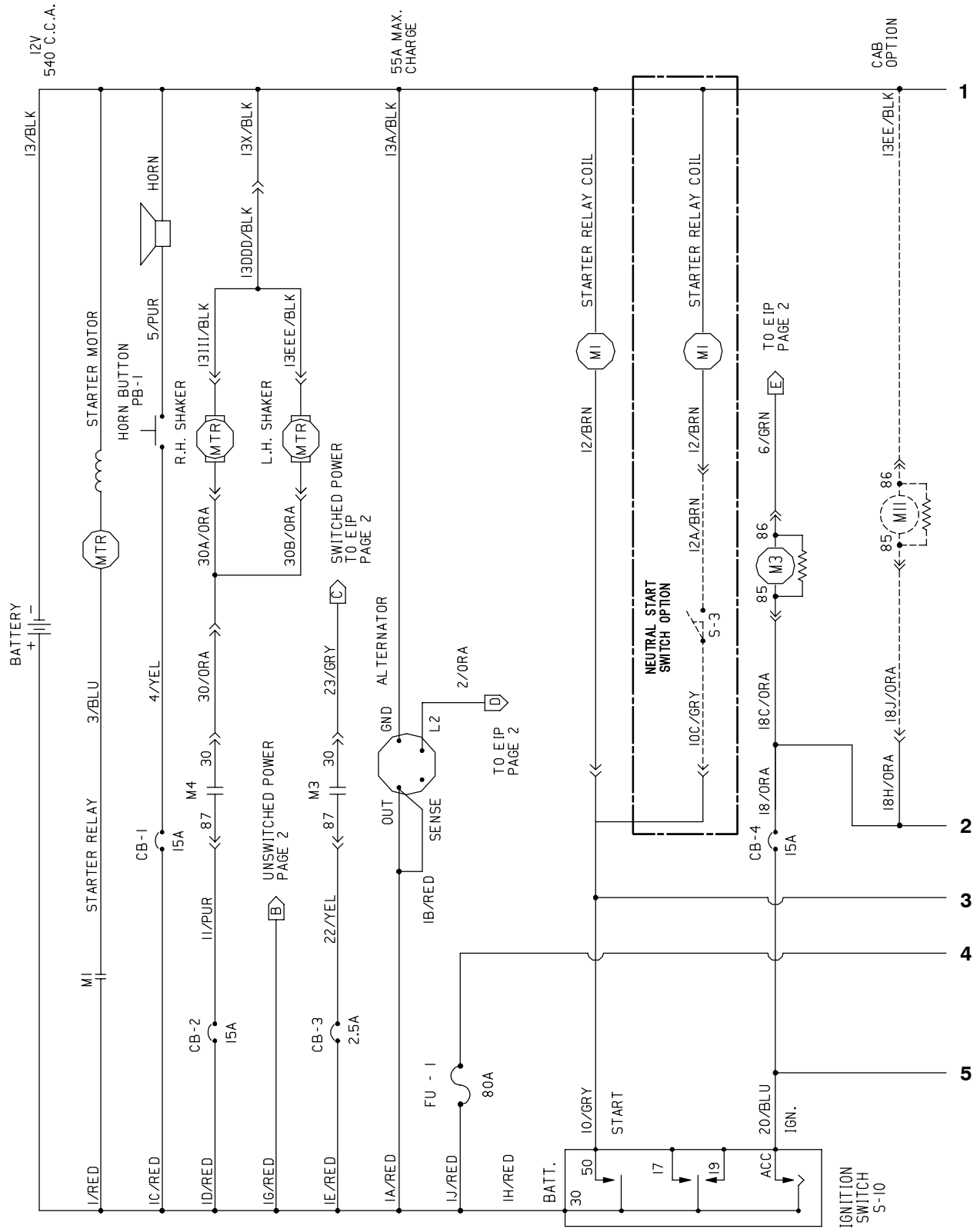

Electrical Schematic 800-810 D (PERKINS 200 SERIES ENGINE)

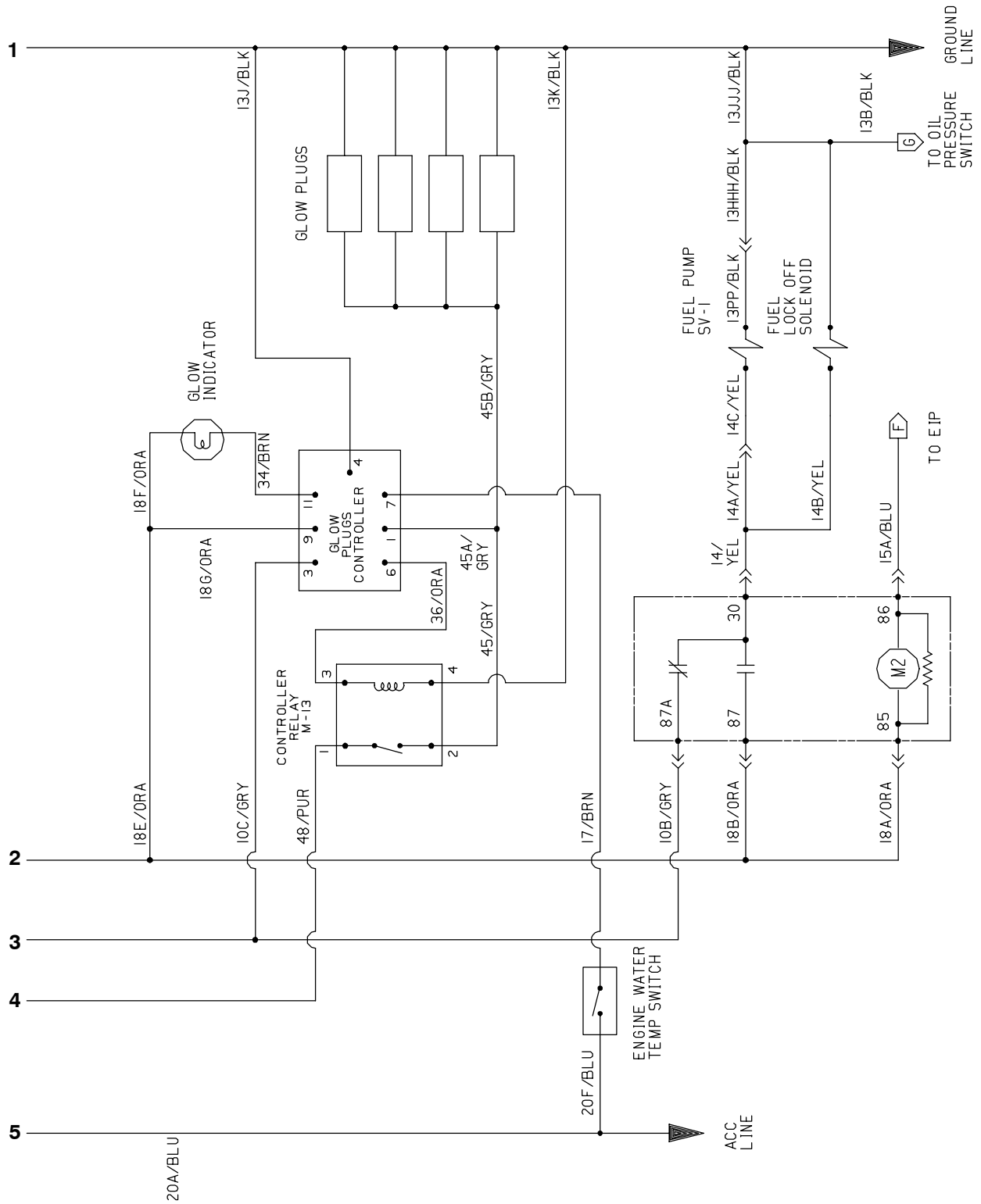

Electrical Schematic 800-810 D (PERKINS 200 SERIES ENGINE)

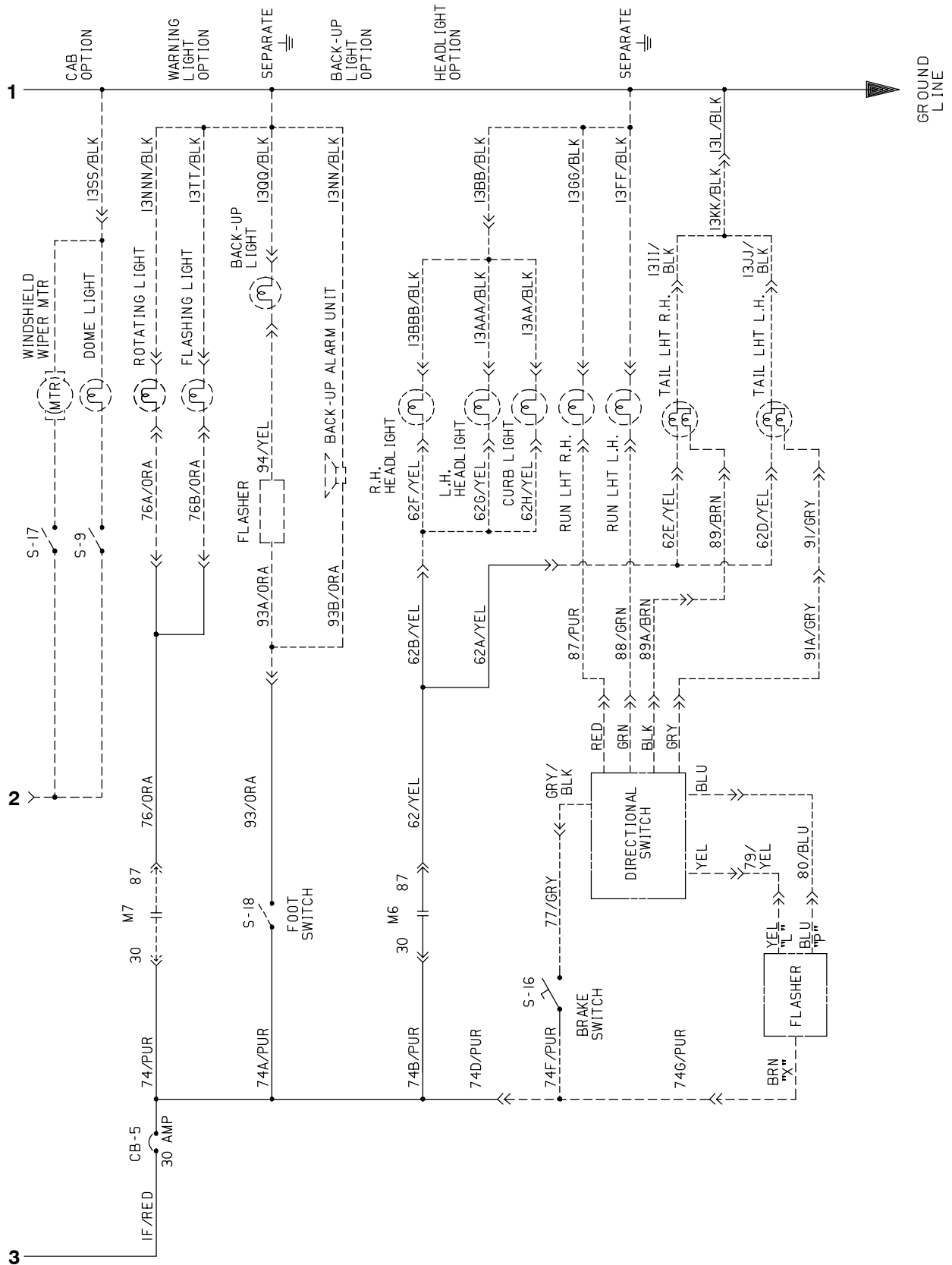

Electrical Schematic 800-810 D (PERKINS 200 SERIES ENGINE)

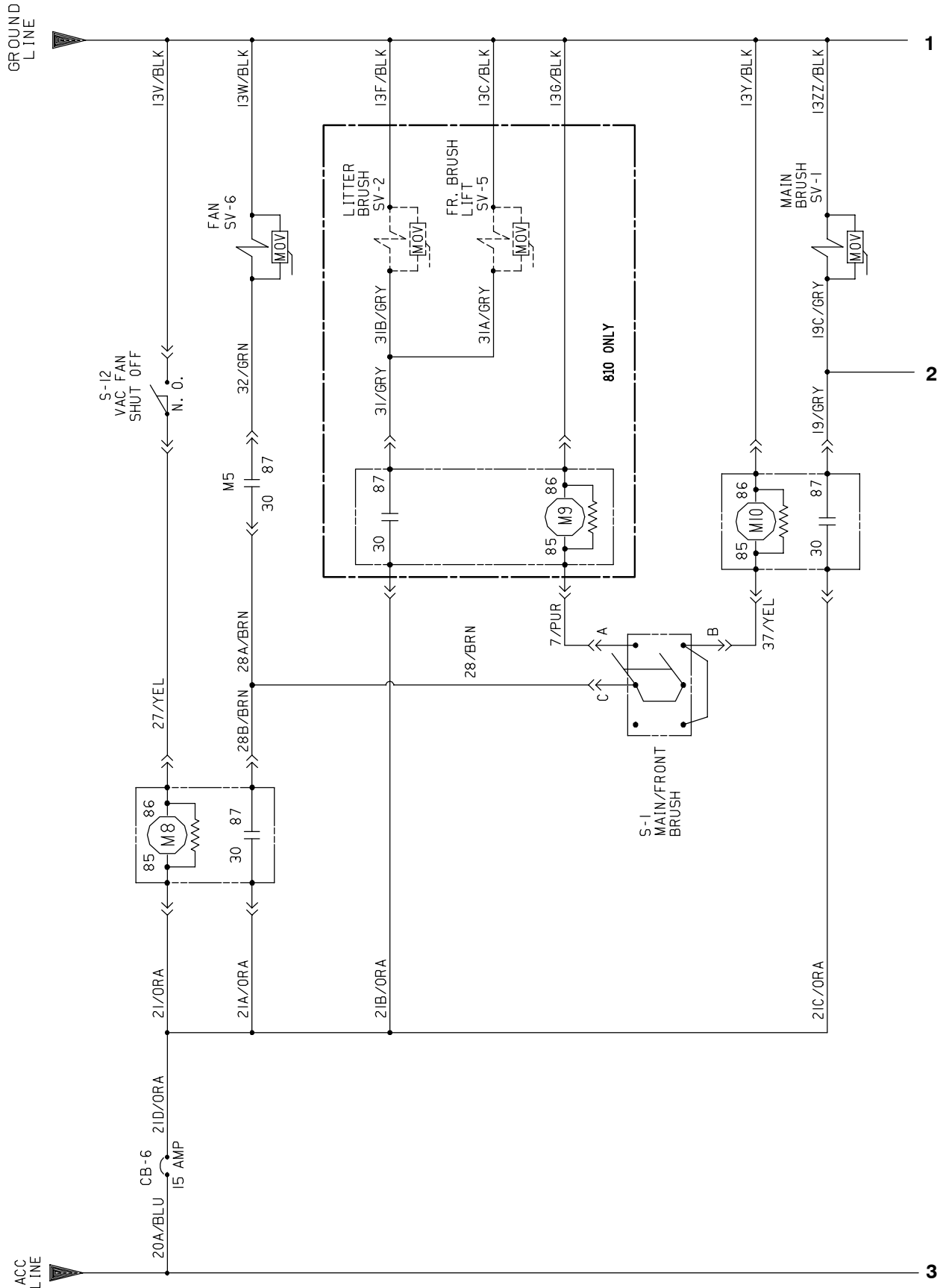

ELECTRICAL

Wire Harnesses Group 800-810 D (PERKINS 200 SERIES ENGINE)

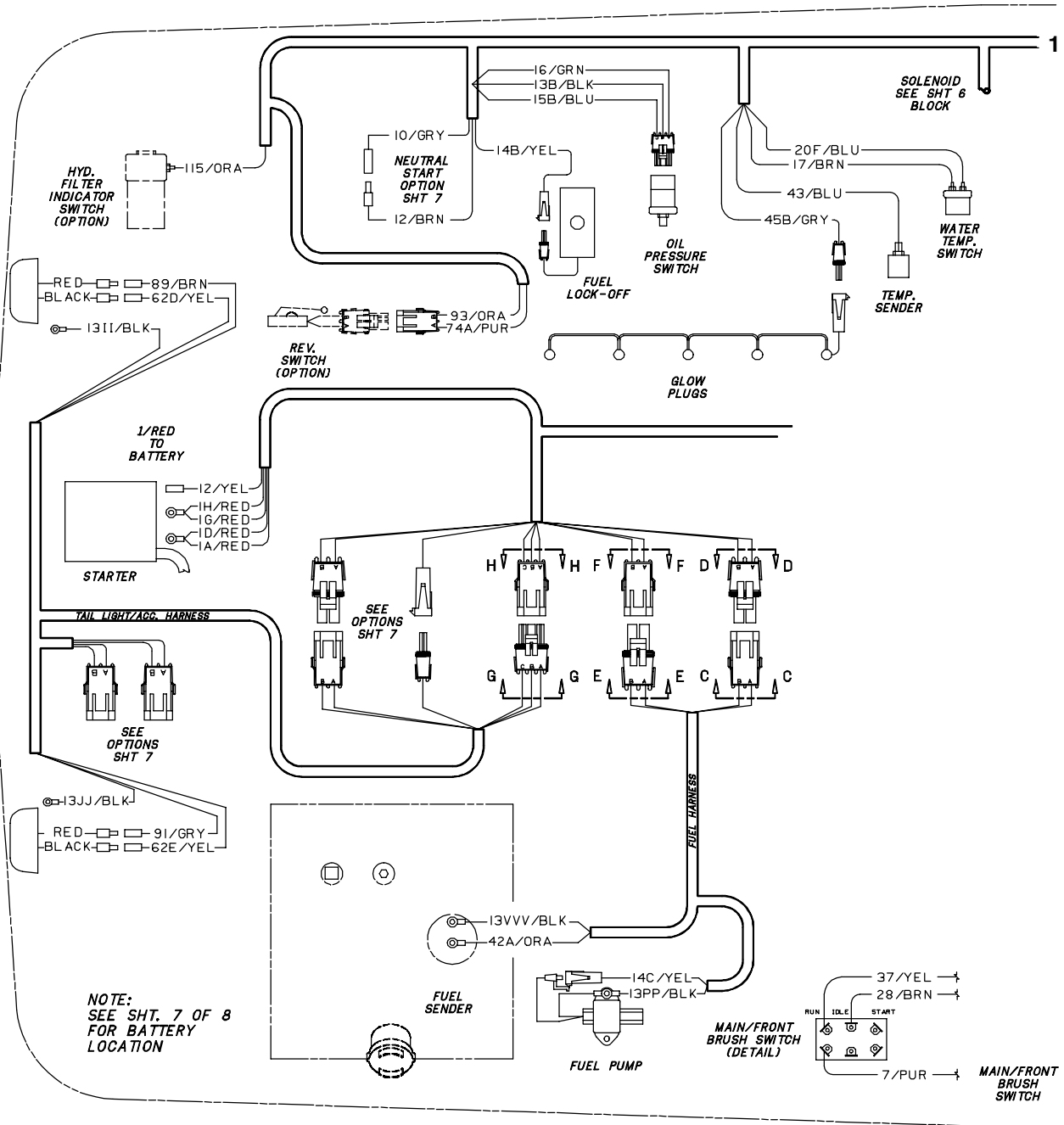

SOCKET NO.	WIRE NO.	COLOR	SOCKET NO.	WIRE NO.	COLOR	SOCKET NO.	WIRE NO.	COLOR	SOCKET NO.	WIRE NO.	COLOR
1	23A	GRY	7	40	YEL	13	42	ORA	19	75	BRN
2	16	GRN	8	PLUG	—	14	2	ORA	20	60	GRN
3	38	PUR	9	PLUG	—	15	15	BLU	21	25	BRN
4	39	GRY	10	PLUG	—	16	29	GRN	22	PLUG	—
5	43	BLU	11	6	GRN	17	PLUG	—	23	13T	BLK
6	24A	PUR	12	PLUG	—	18	PLUG	—	24	13U	BLK

Wire Harnesses Group 800-810 D (PERKINS 200 SERIES ENGINE)

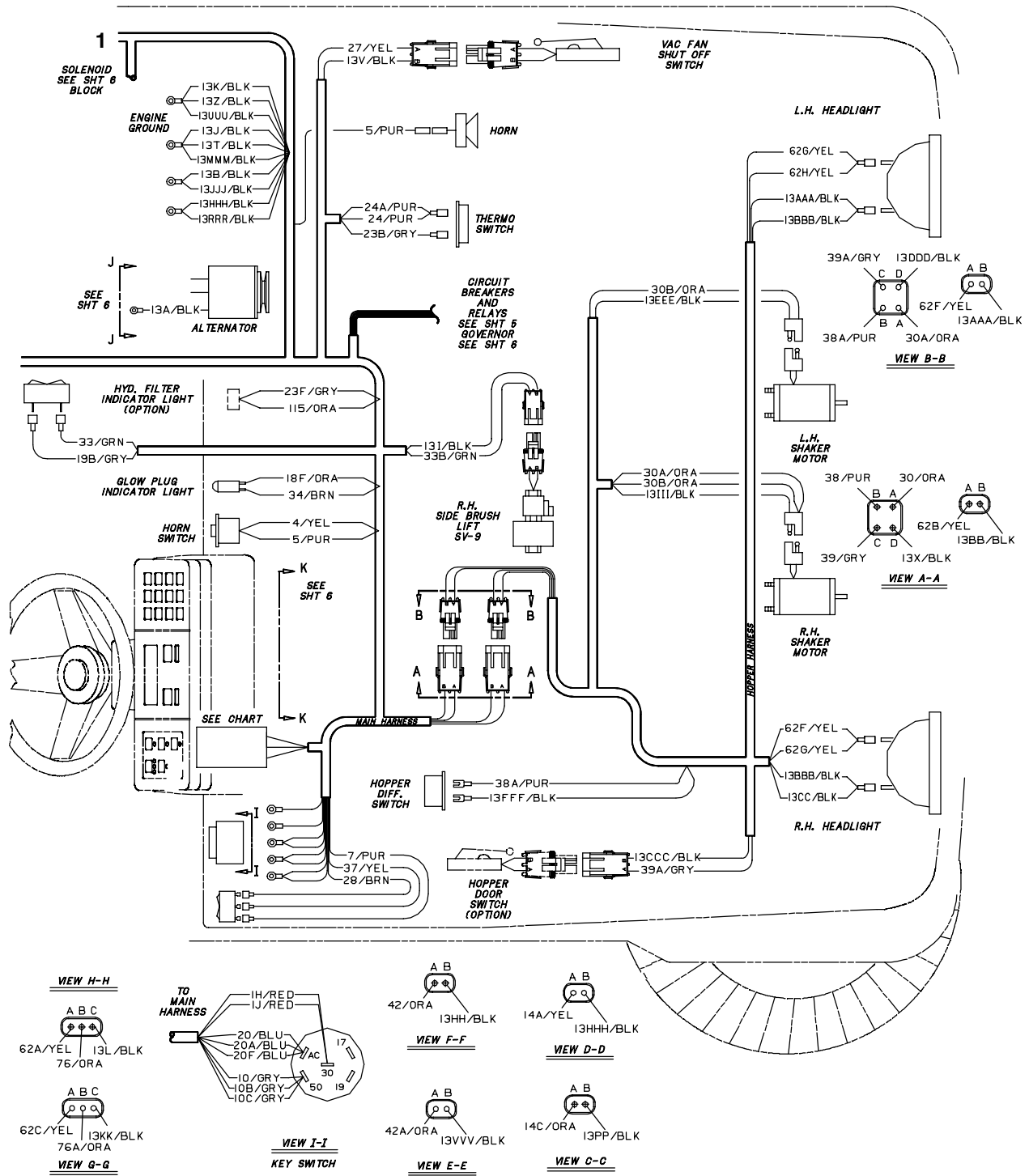

Wire Harnesses Group 800-810 D (PERKINS 200 SERIES ENGINE)

RELAYS

- M3 ELECTRONIC INSTRUMENT PANEL
- M4 SHAKER MOTOR
- M5 VAC FAN SOLENOID
- M6 HEADLIGHTS
- M7 ROTATING/FLASHING LIGHTS
- M8 HOPPER LIFT
- M9 FRONT BRUSH
- M10 MAIN BRUSH

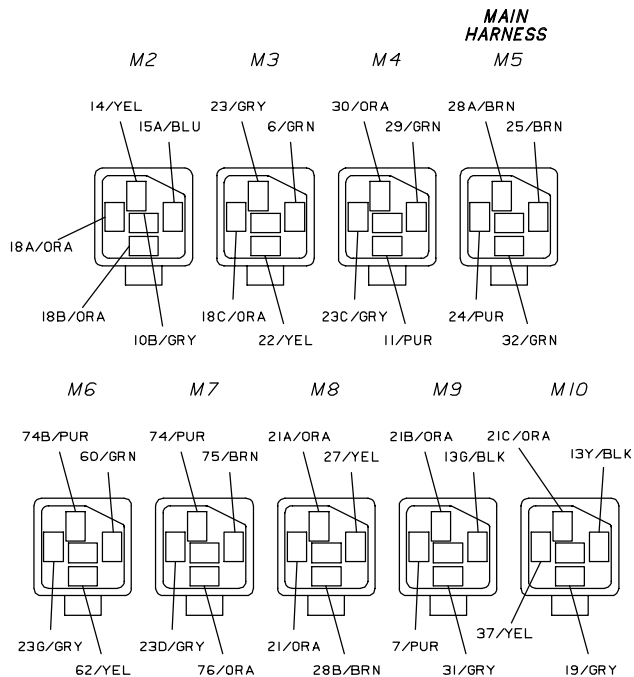
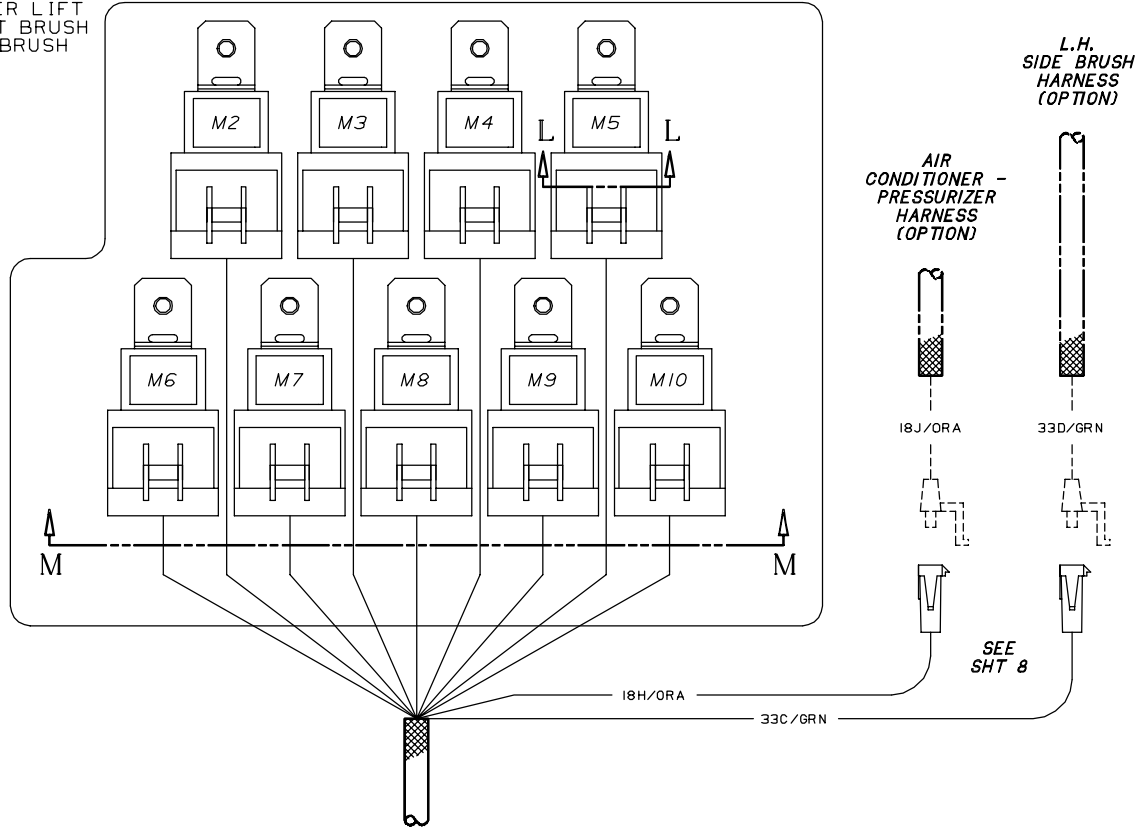

VIEW M-M

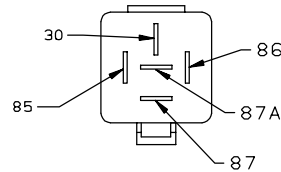

- 85 COIL +
- 86 COIL -
- 30 COMMON CONTACT
- 87 N.O. CONTACT
- 87A N.C. CONTACT

SECTION L-L

Wire Harnesses Group 800-810 D (PERKINS 200 SERIES ENGINE)

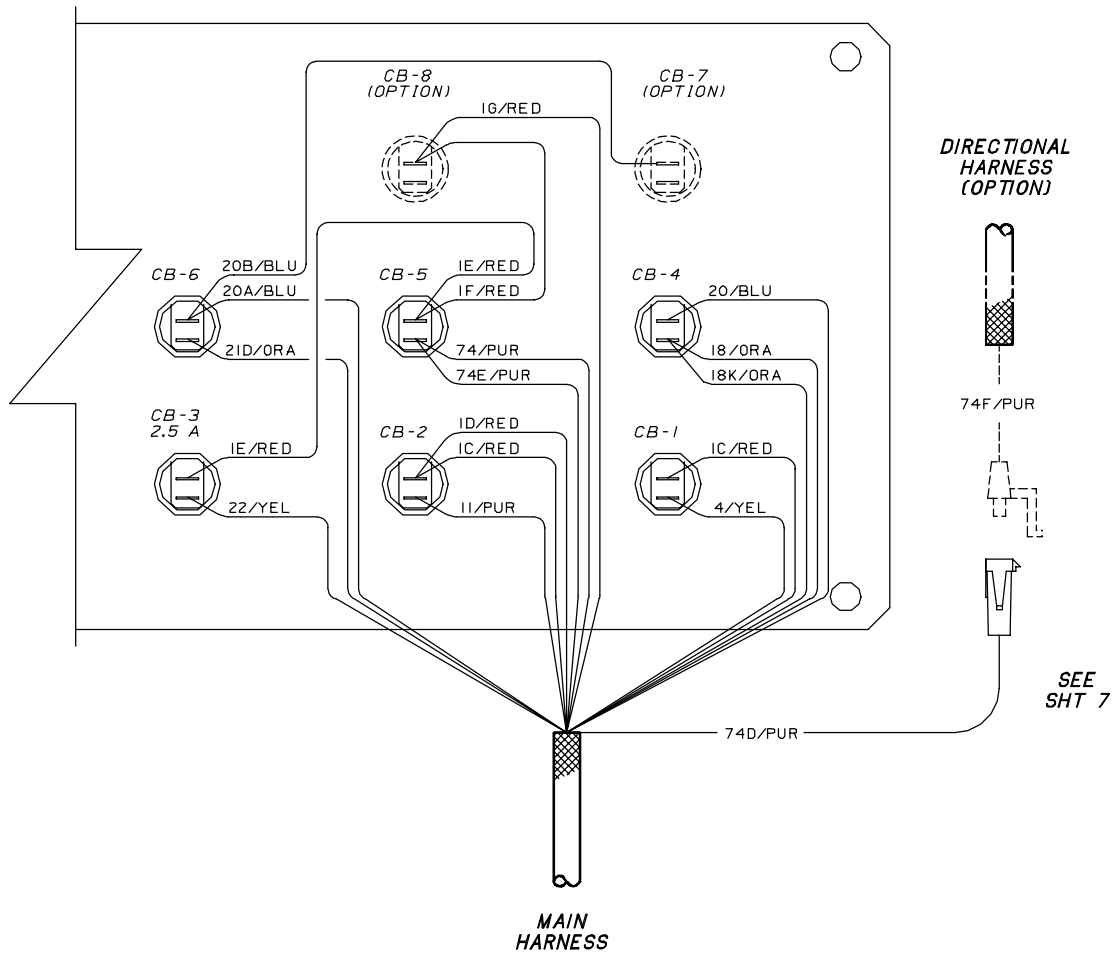

CIRCUIT BREAKERS

- CB-1 HORN
- CB-2 SHAKER MOTOR
- CB-3 VAC FAN RELAY, SHAKER RELAY, WARNING LIGHT & HEADLIGHT
- CB-4 ELECTRONIC INSTRUMENT PANEL
- CB-5 ROTATING LIGHT & BACK-UP ALARM
- CB-6 HOPPER LIFT RELAY, FRONT/MAIN BRUSH
- CB-7 LEFT HAND SIDE BRUSH
- CB-8 CAB ACCESSORIES

Wire Harnesses Group 800-810 D (PERKINS 200 SERIES ENGINE)

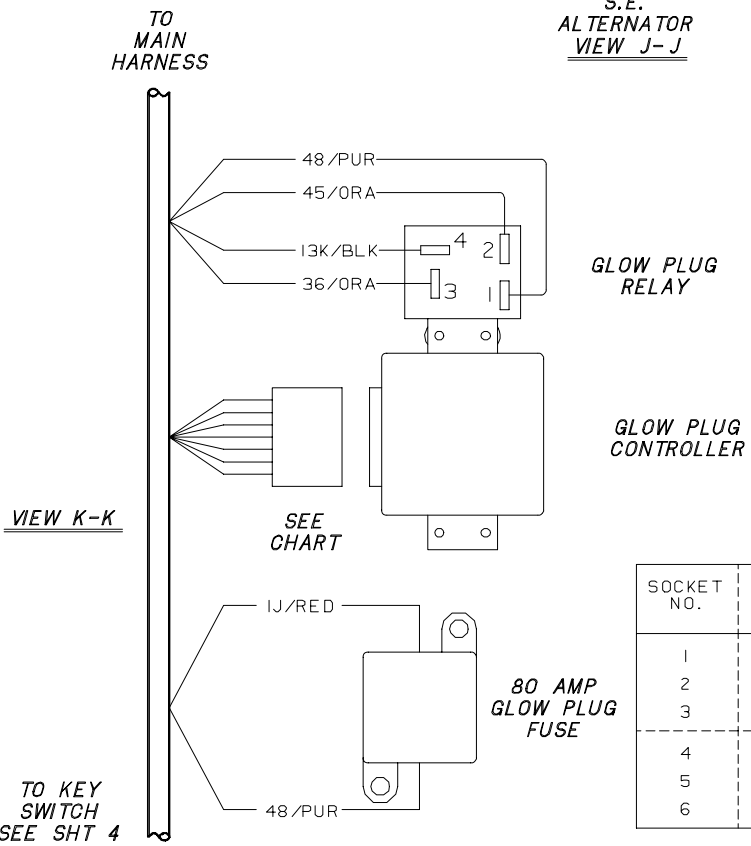
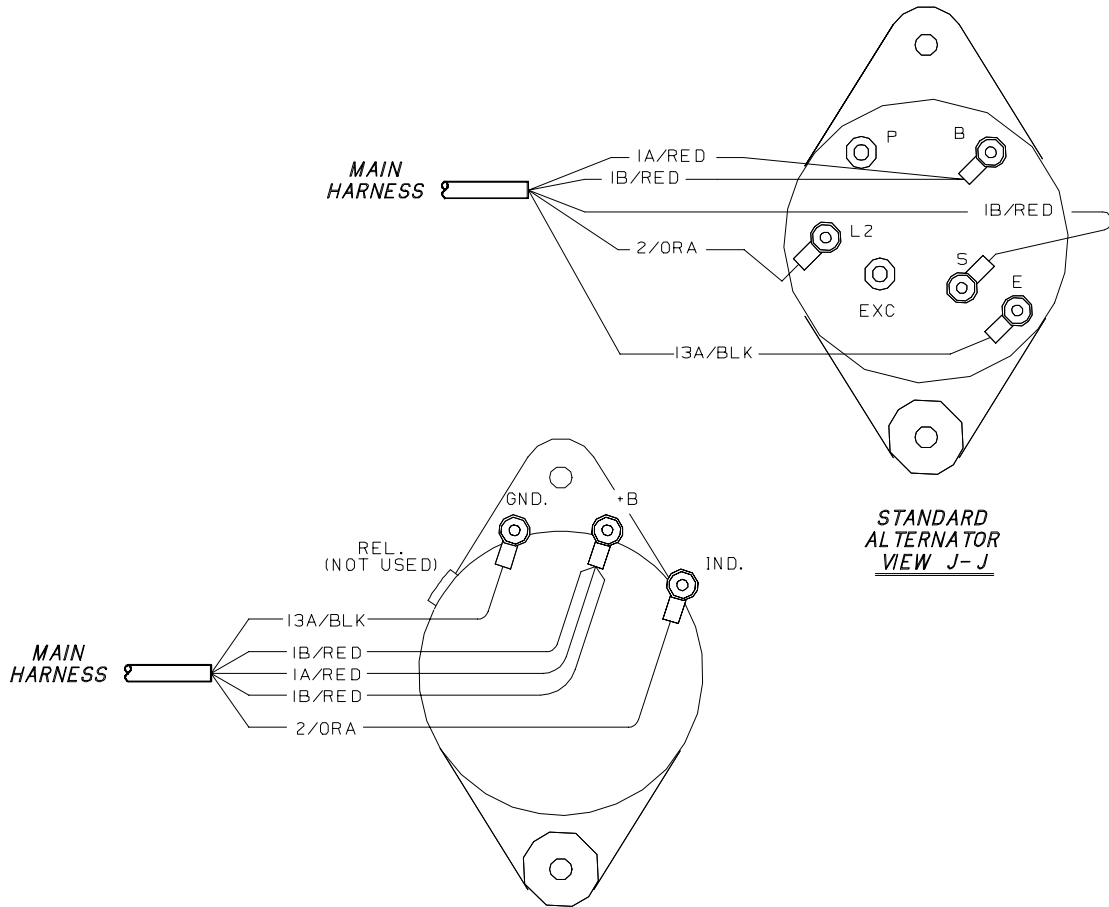

SOCKET NO.	WIRE NO.	COLOR	SOCKET NO.	WIRE NO.	COLOR
1	45A	GRY	7	17	BRN
2	—	—	8	—	—
3	10C	GRY	9	18G	ORA
4	13J	BLK	10	—	—
5	—	—	11	34	BRN
6	36	ORA			

Wire Harnesses Group 800-810 D (PERKINS 200 SERIES ENGINE)

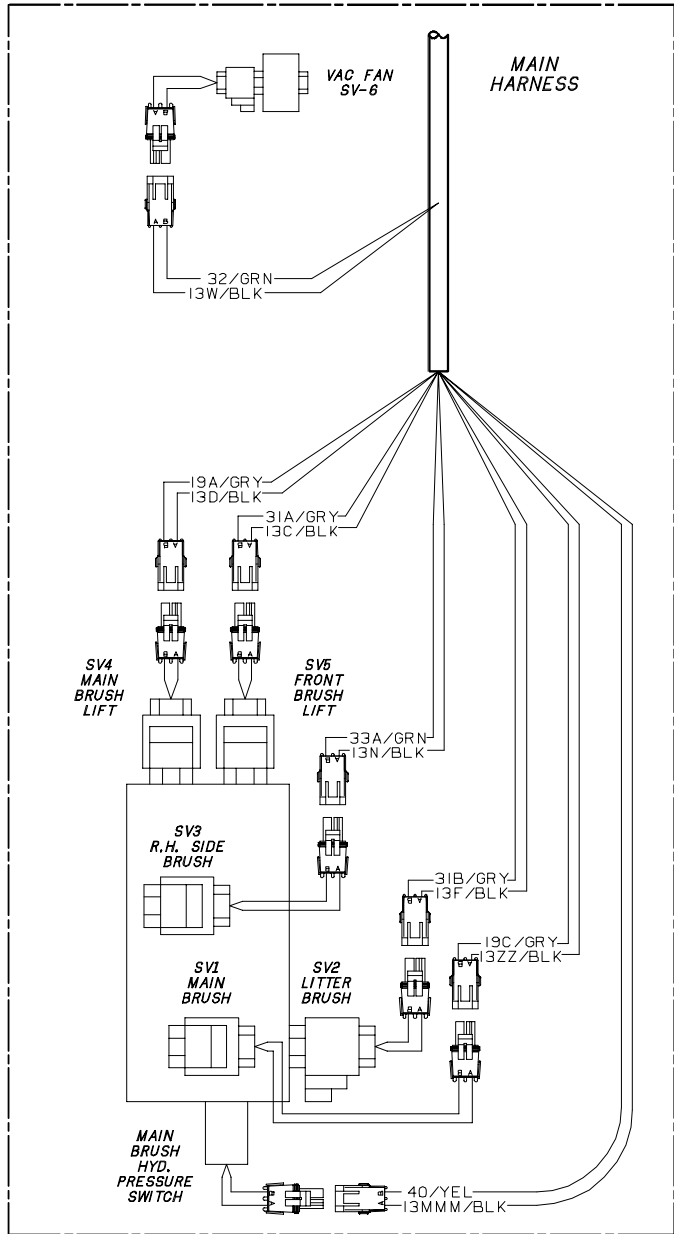
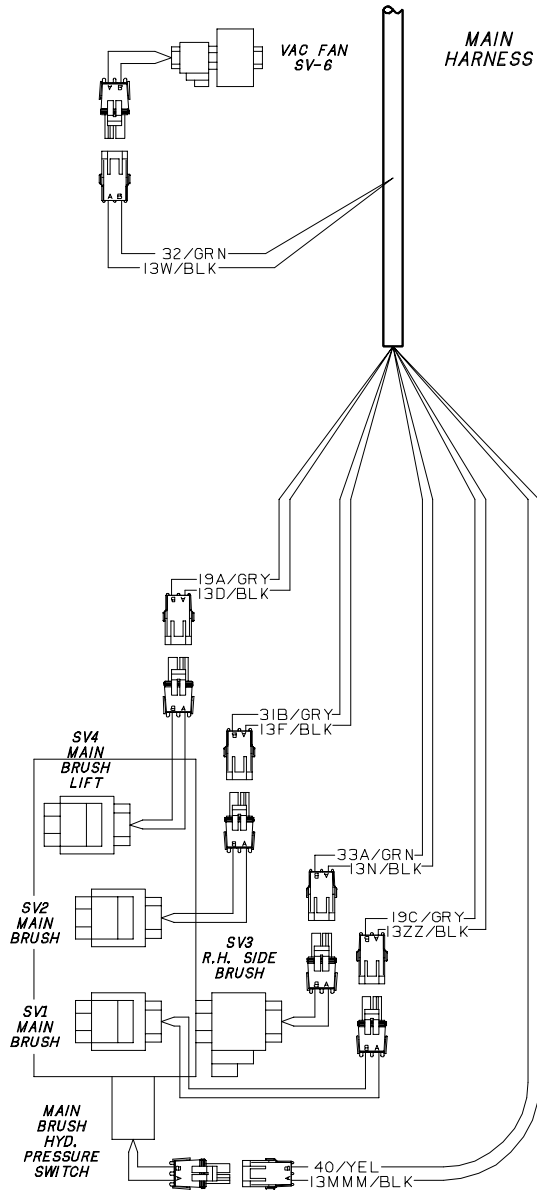

**810
MODEL
ONLY**

Wire Harnesses Group 800-810 D (PERKINS 200 SERIES ENGINE)

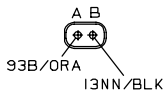
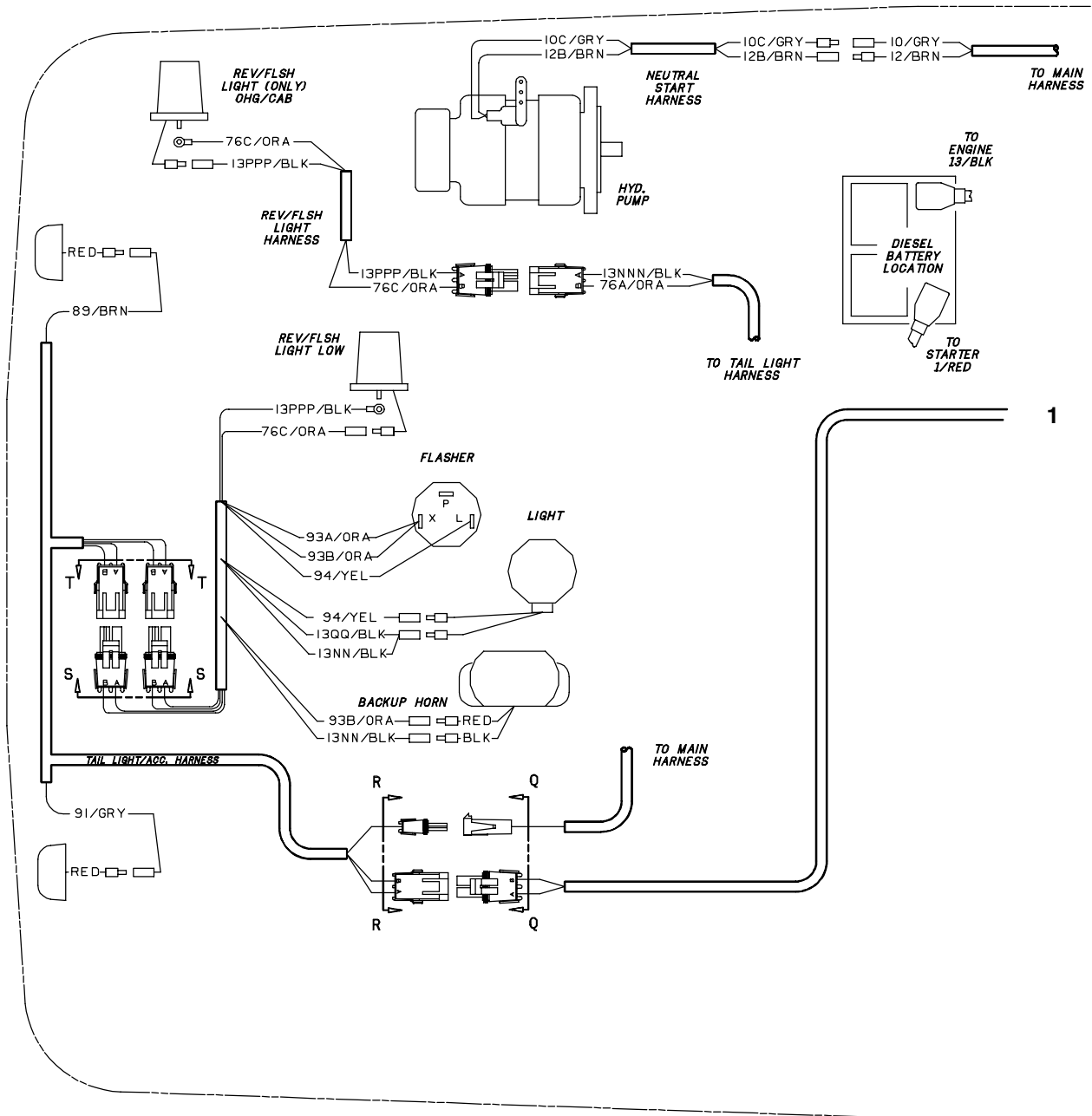

VIEW T-T

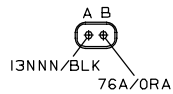

VIEW Q-Q



VIEW S-S

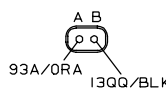

VIEW R-R

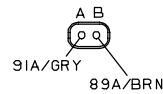
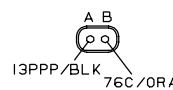

Wire Harnesses Group 800-810 D (PERKINS 200 SERIES ENGINE)

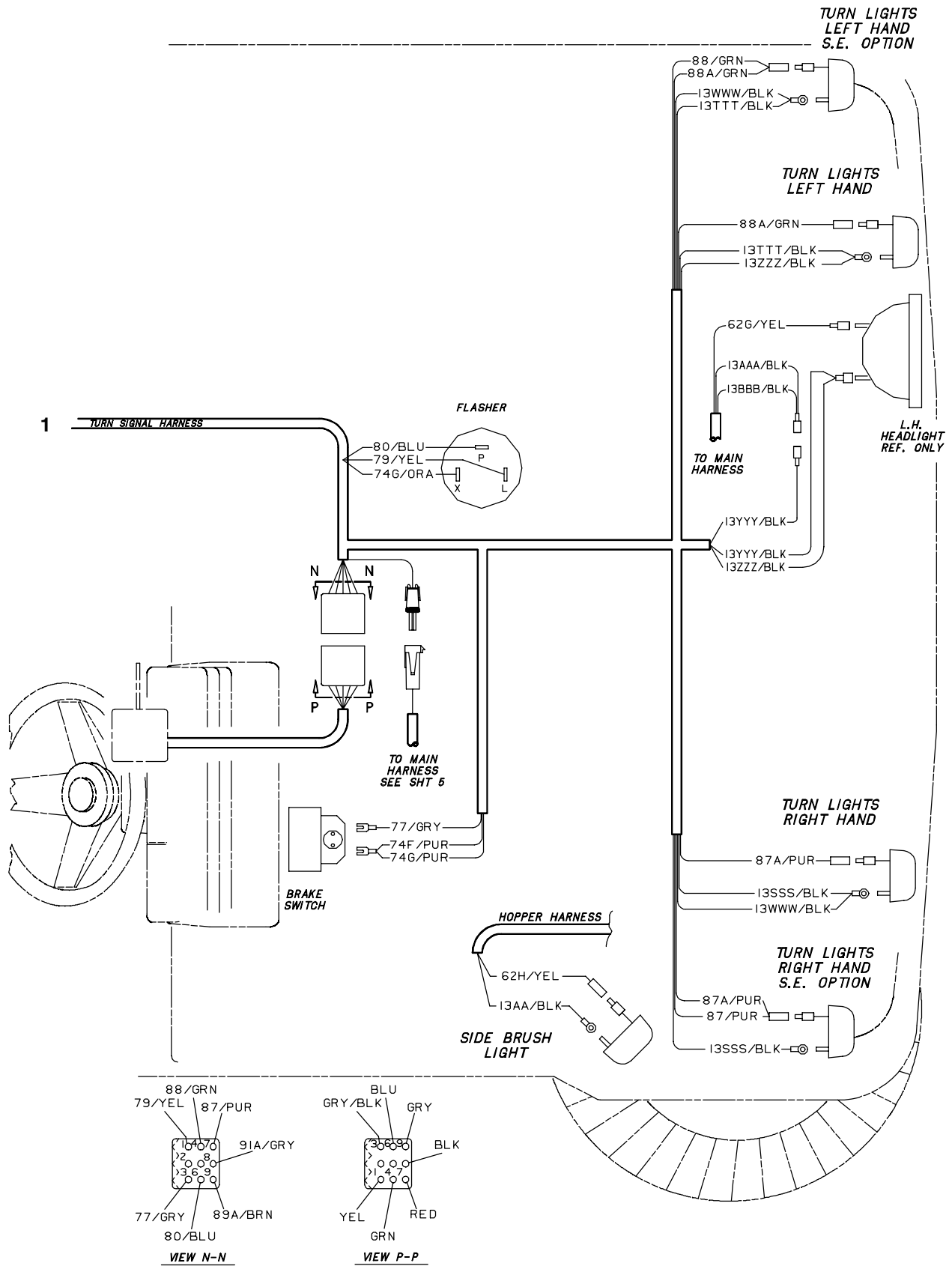

Wire Harnesses Group 800-810 D (PERKINS 200 SERIES ENGINE)

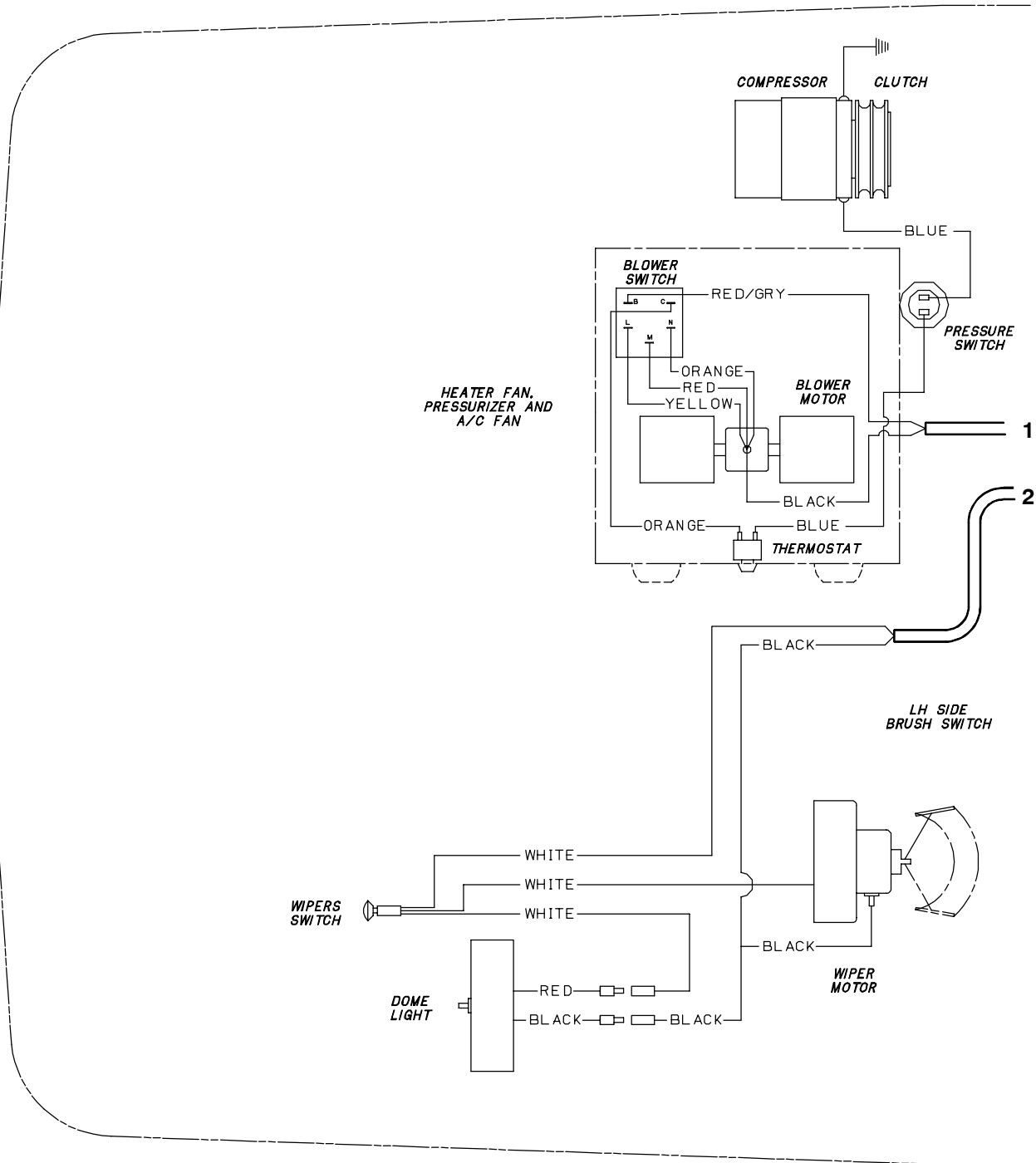

Wire Harnesses Group 800-810 D (PERKINS 200 SERIES ENGINE)

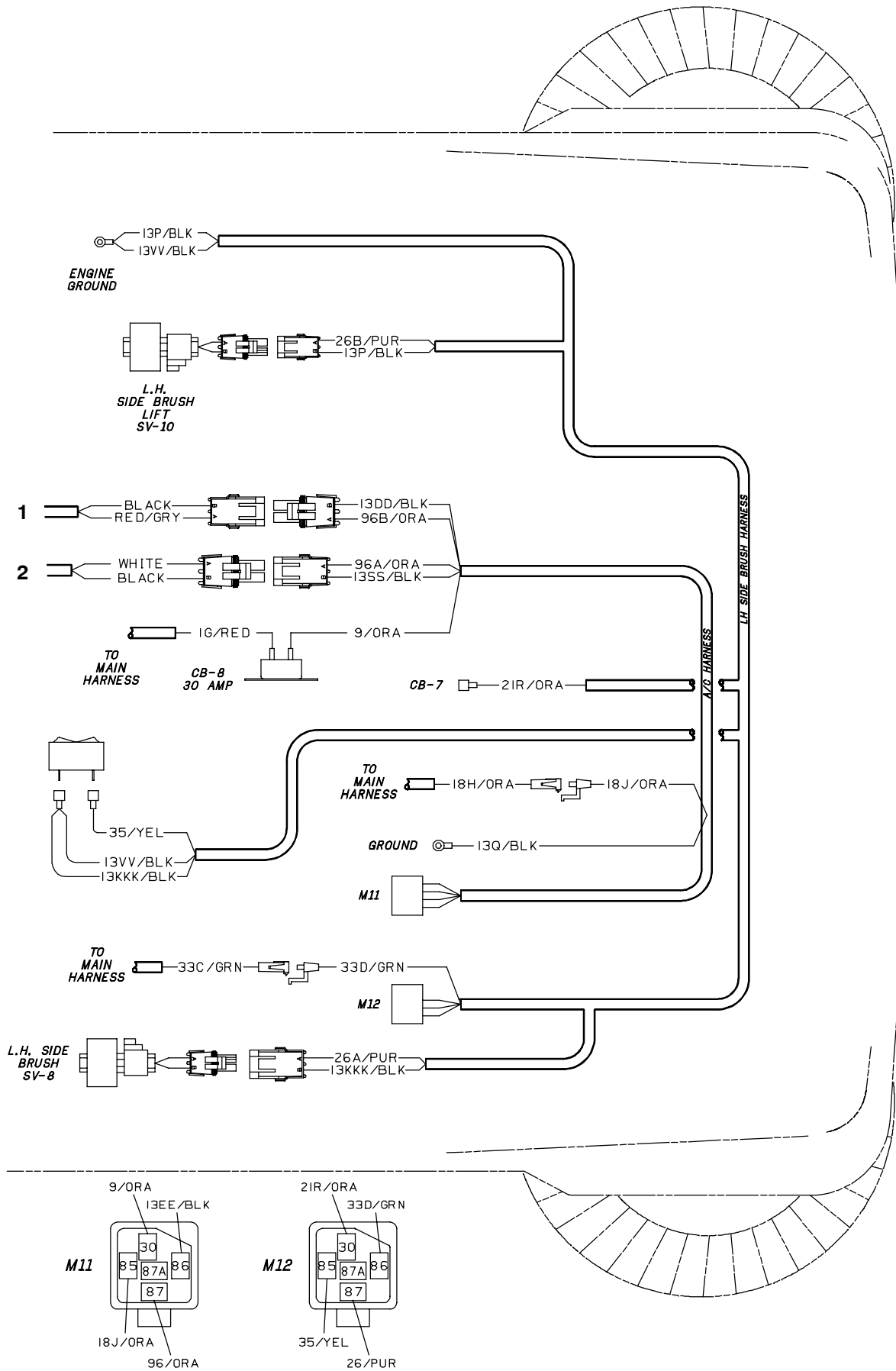

Electrical Schematic 800-810 D (PERKINS 700 SERIES ENGINE)

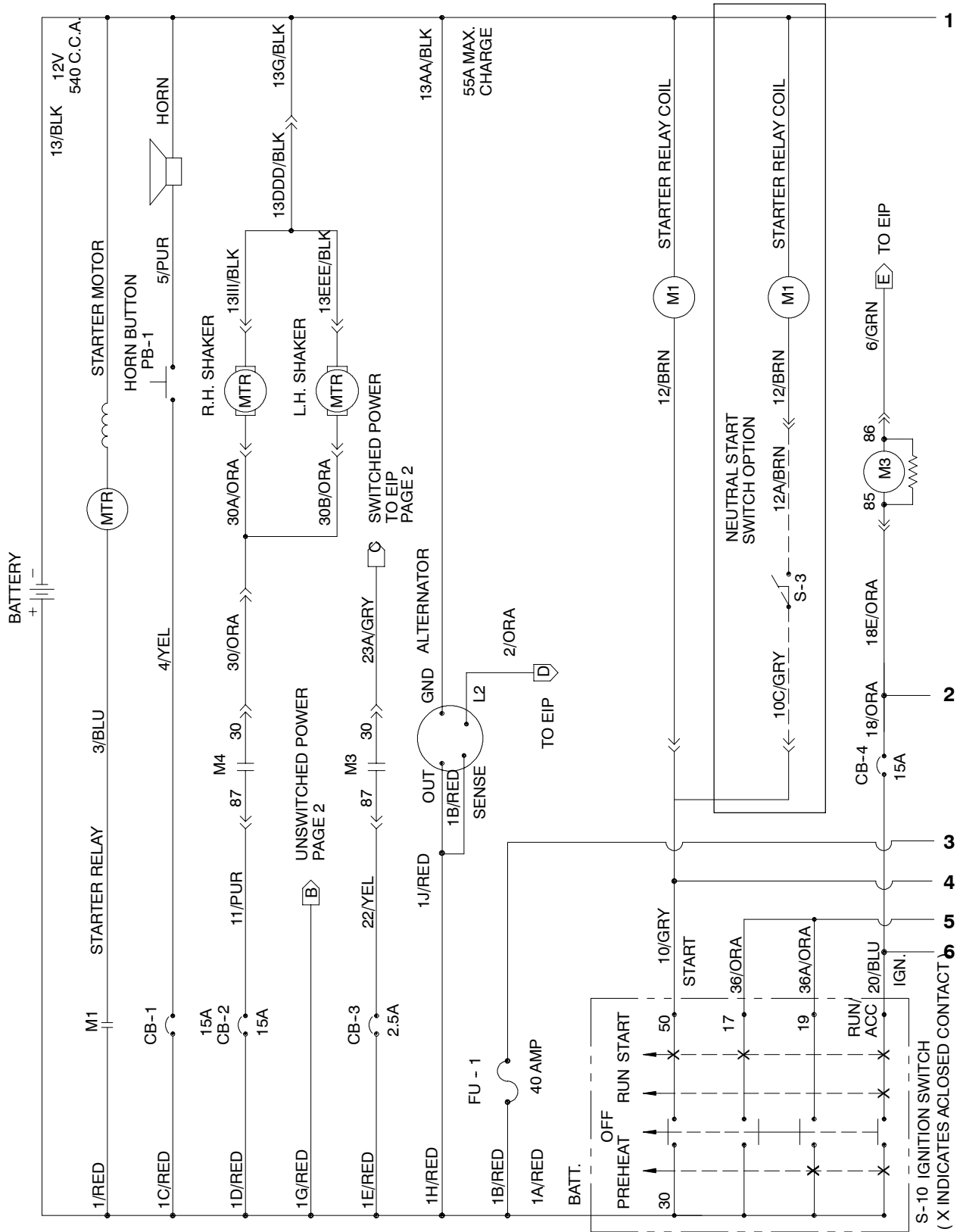

Electrical Schematic 800-810 D (PERKINS 700 SERIES ENGINE)

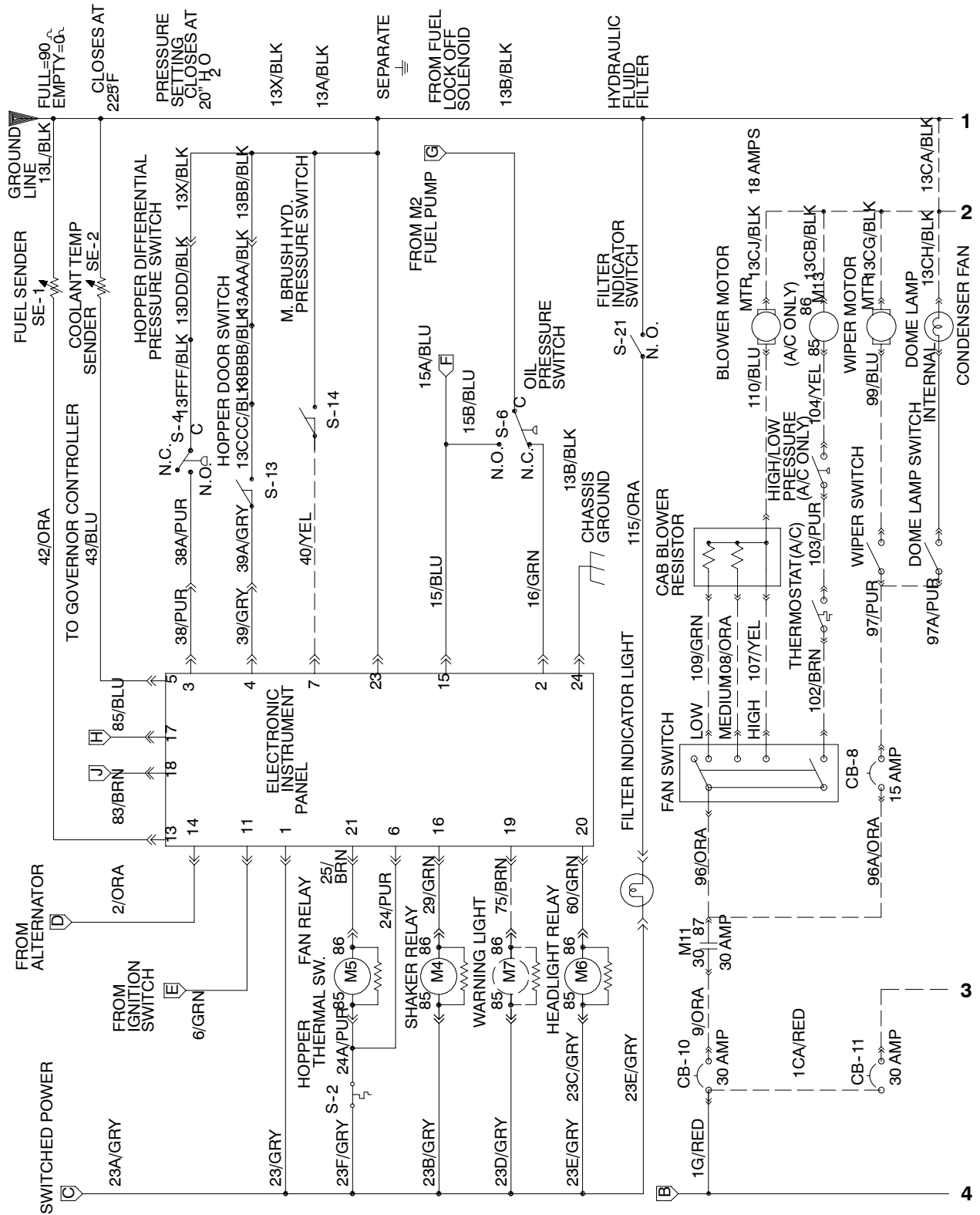

Electrical Schematic 800-810 D (PERKINS 700 SERIES ENGINE)

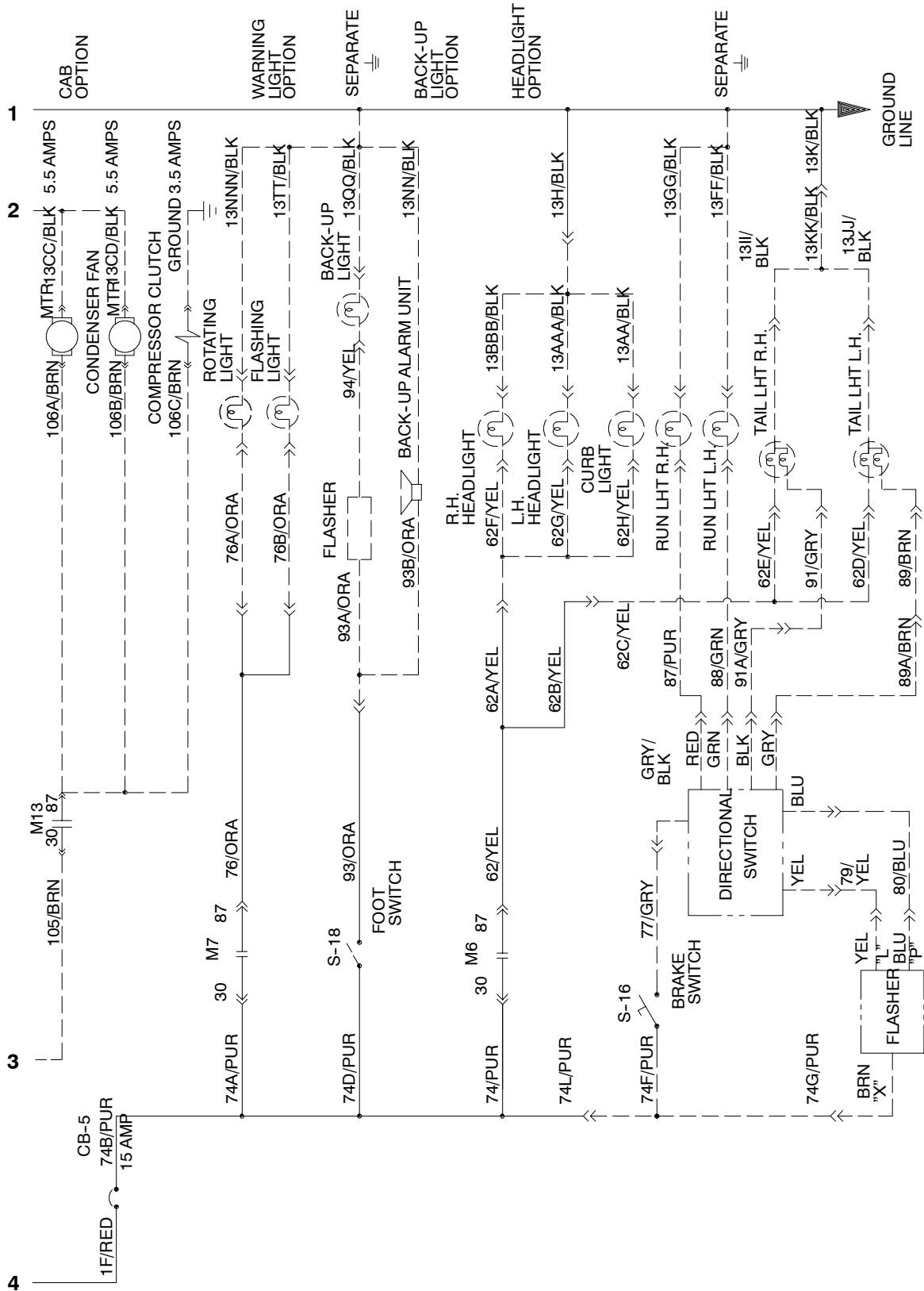

Electrical Schematic 800-810 D (PERKINS 700 SERIES ENGINE)

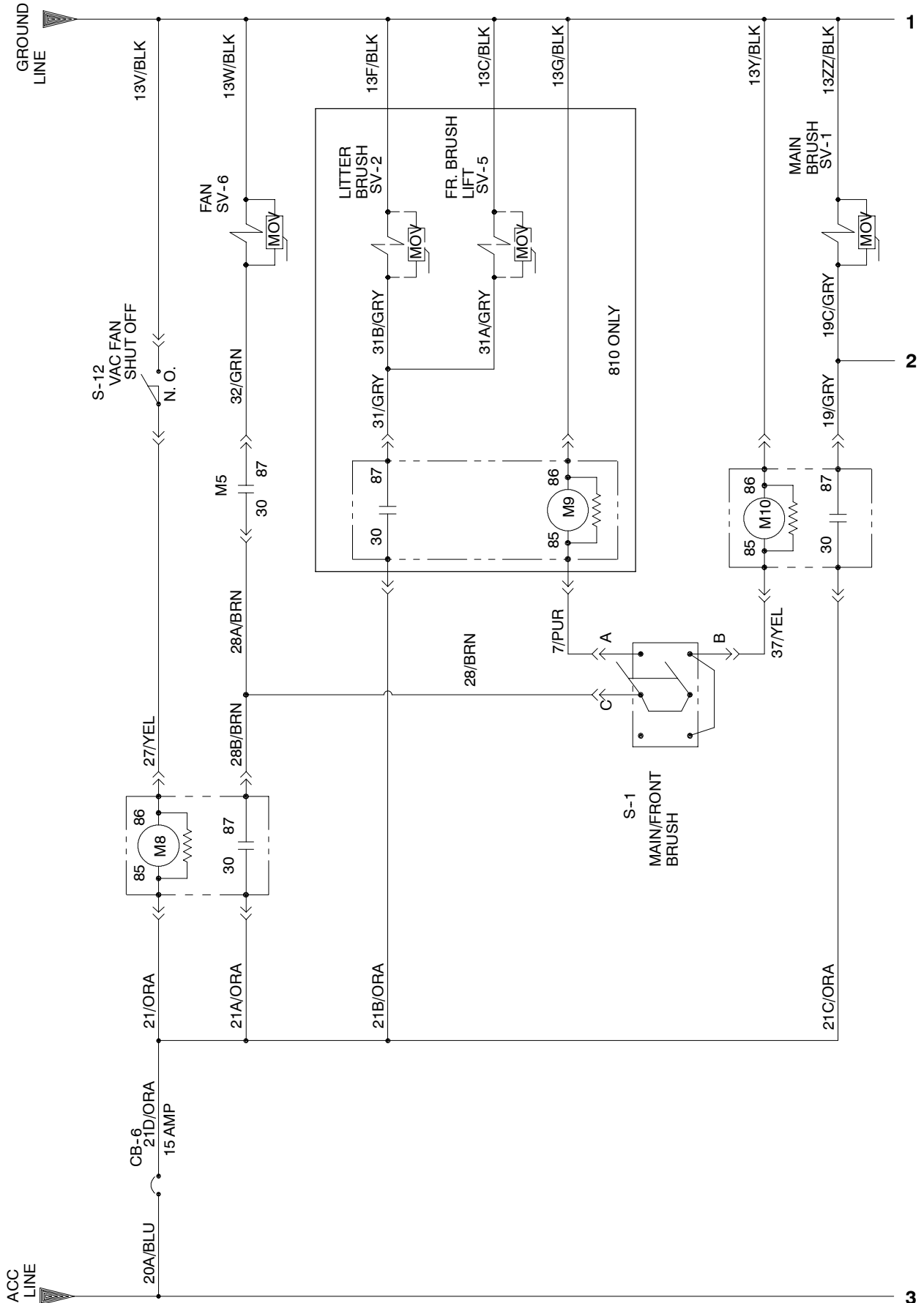

Electrical Schematic 800-810 D (PERKINS 700 SERIES ENGINE)

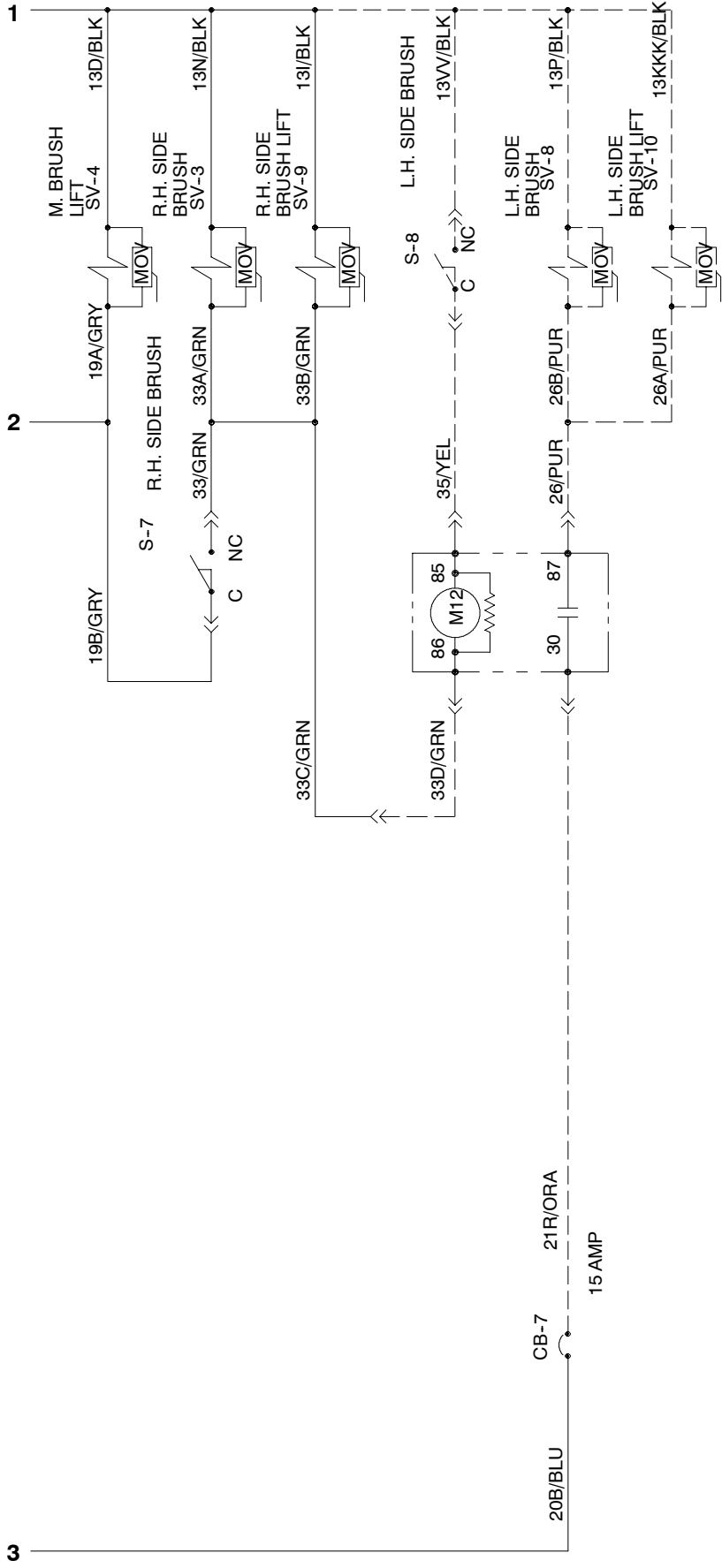

LEGEND			
M	POWER RELAY	HM	HOURMETER
MTR	MOTOR	SV	SOLENOID VALVE
CB	CIRCUIT BREAKER	S	SWITCH
PM	PERMANENT MAGNET	ACC	ACCESSORY
J	JACK-FEM. SOCKET	GND	GROUND CHASSIS
P	PLUG-MALE PIN	C	COMMON
PB	PUSHBUTTON	N.O.	NORMALLY OPEN
VM	VOLTMETER	N.C.	NORMALLY CLOSED
FU	FUSE	NOV	METAL OXIDE VARISTOR

TROUBLESHOOTING

The troubleshooting charts that follow are organized so they lead you through the circuits. They include flow charts and instructions for you as to where to insert your test instruments.

ENGINE RUN

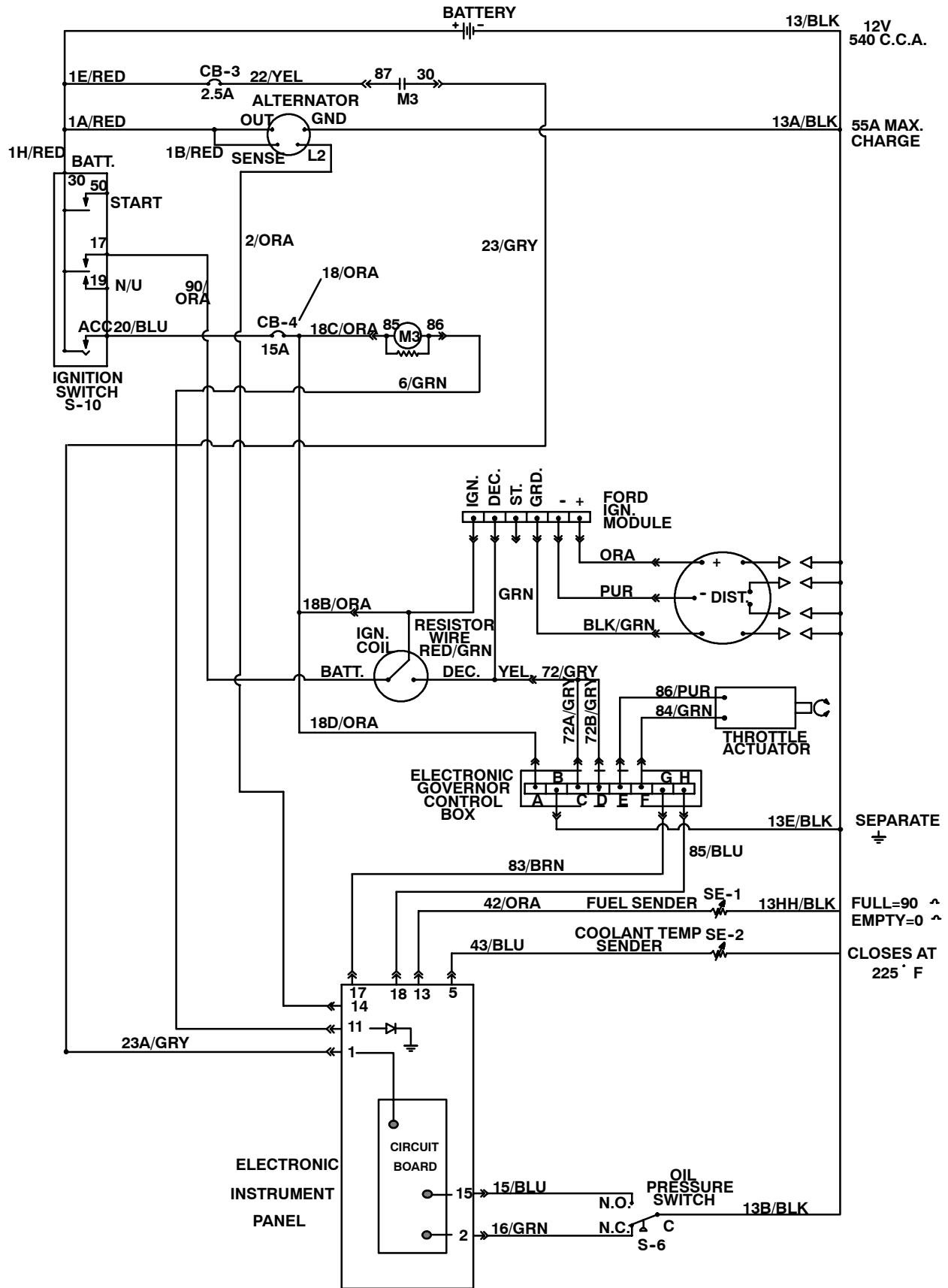

ELECTRICAL

SHAKER

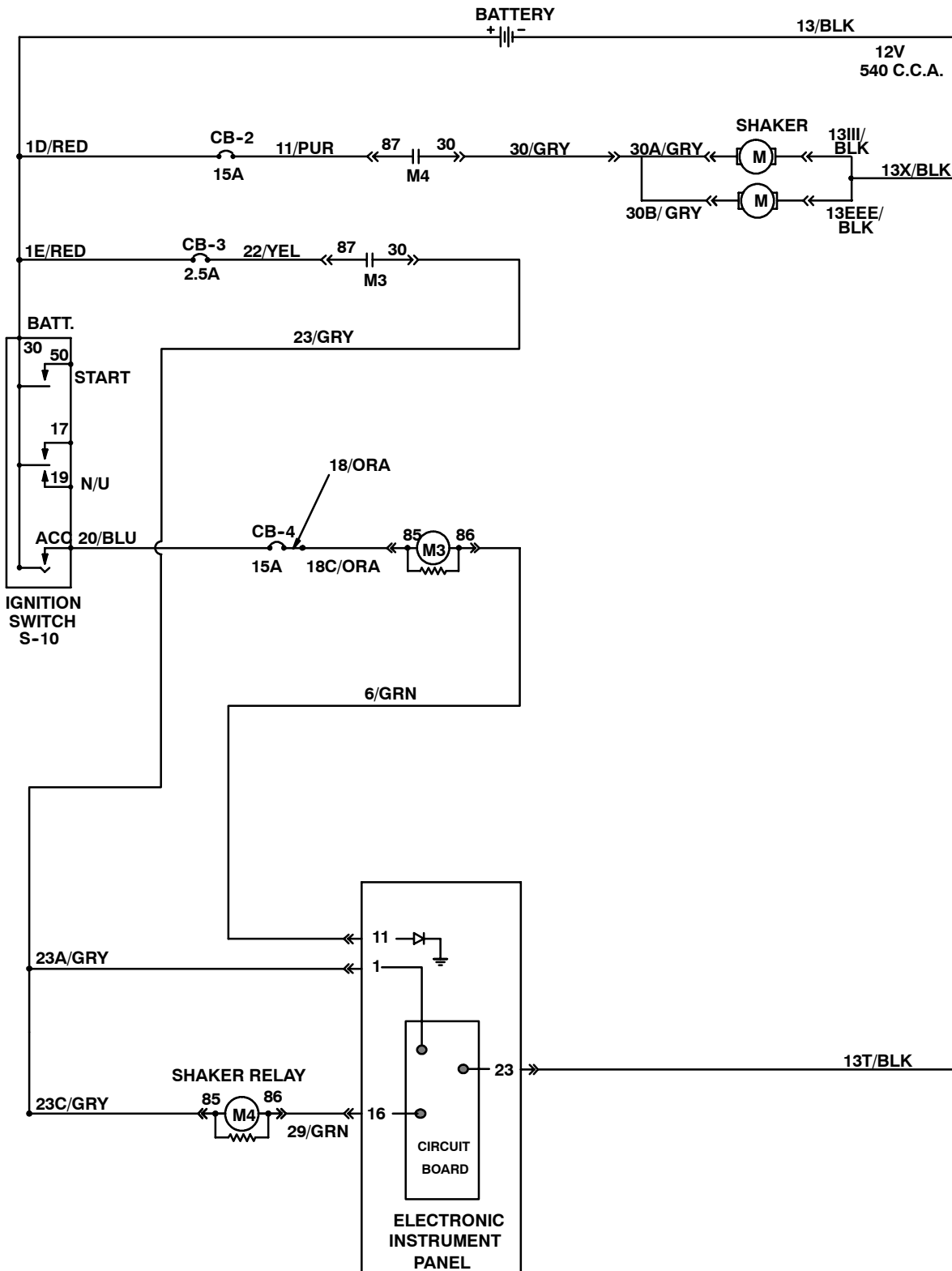

SHAKER FAILURE

ACTIVATING THE SHAKER SWITCH TURNS ON A 45 SECOND TIMER.

THIS MAY CAUSE AN INCORRECT READING.

TEST ASSUMES SHAKER TIMER IS ACTIVE UNLESS KEY IS OFF.

RESETTING SWITCH WILL BE NECESSARY.

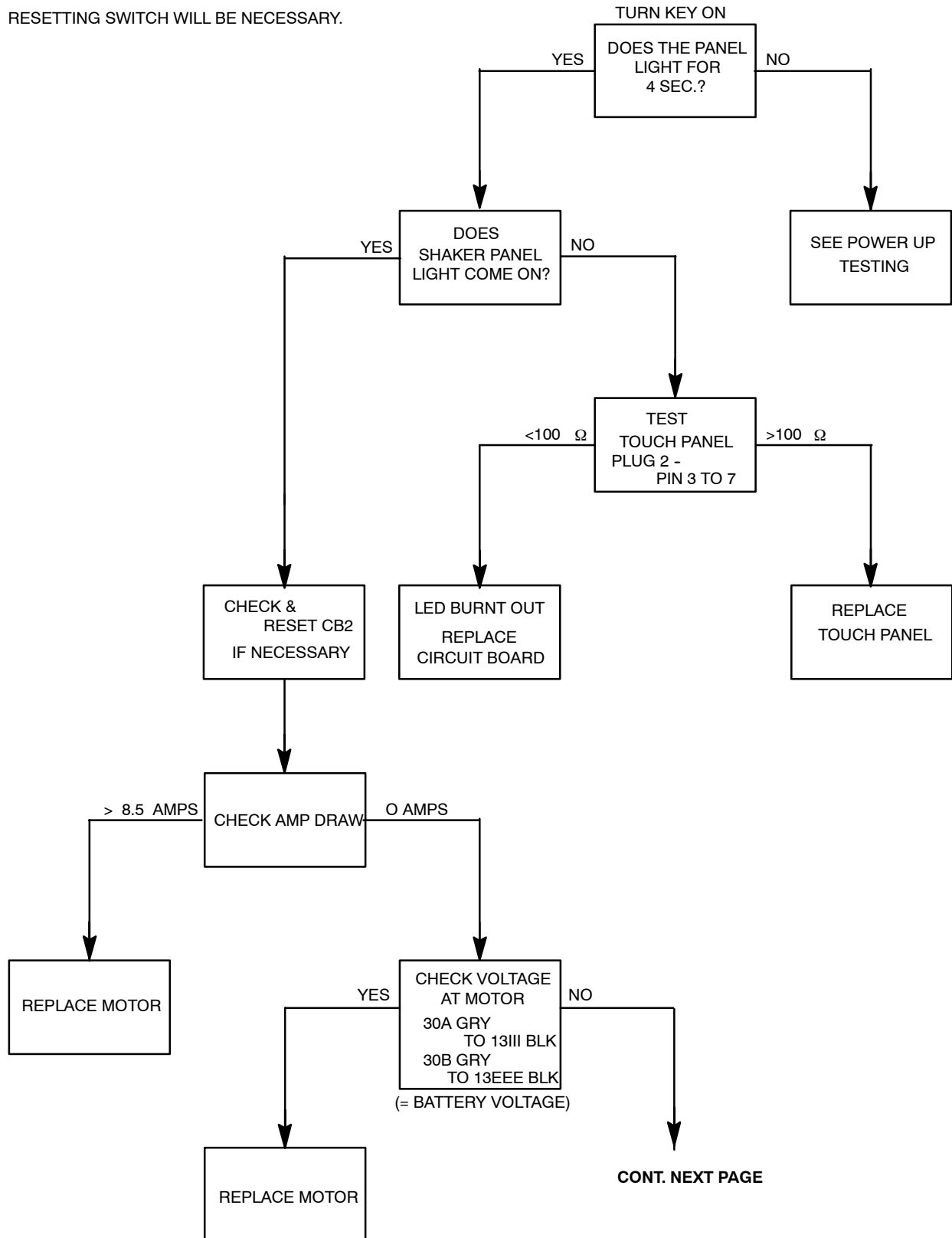

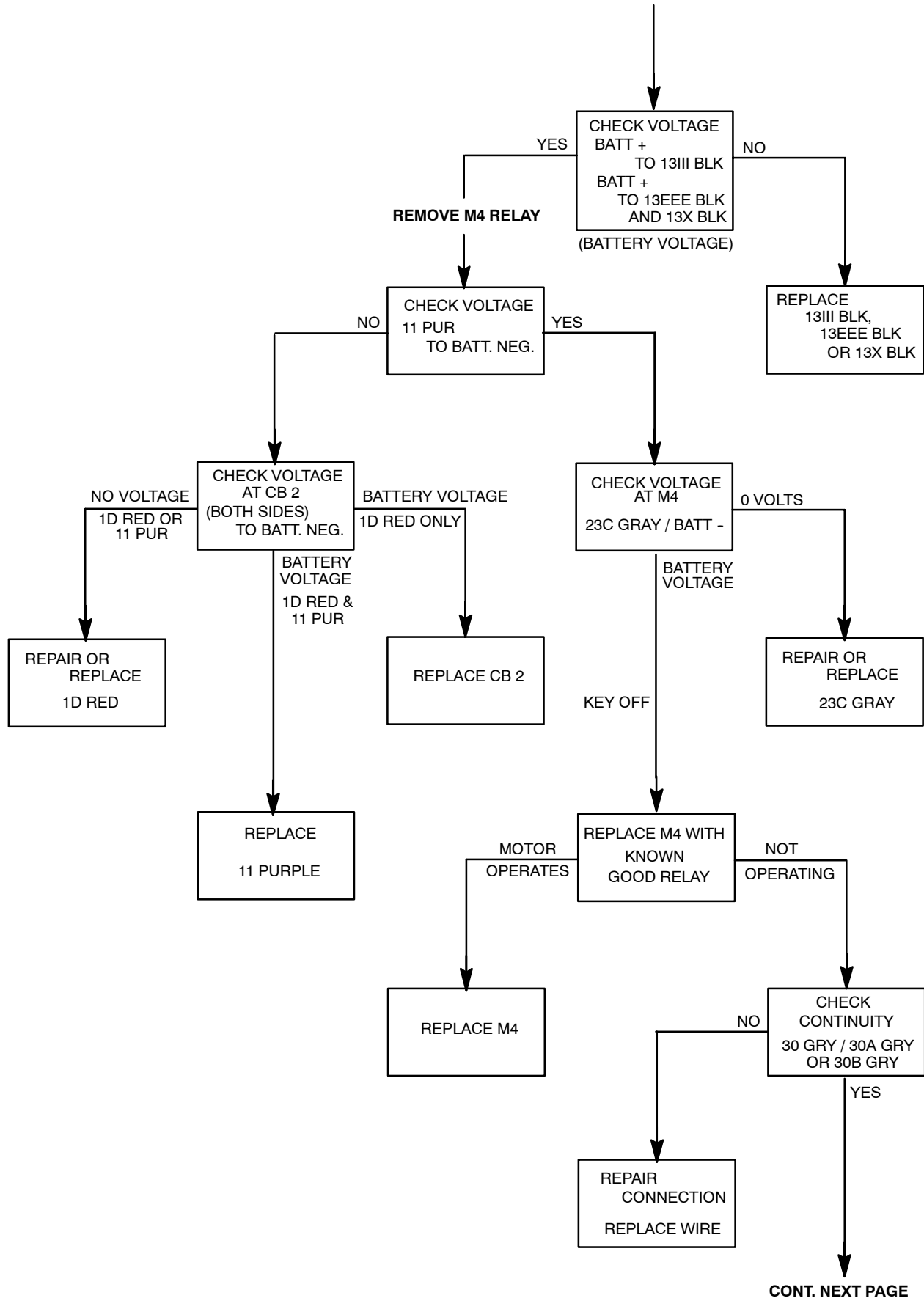

CONT. NEXT PAGE

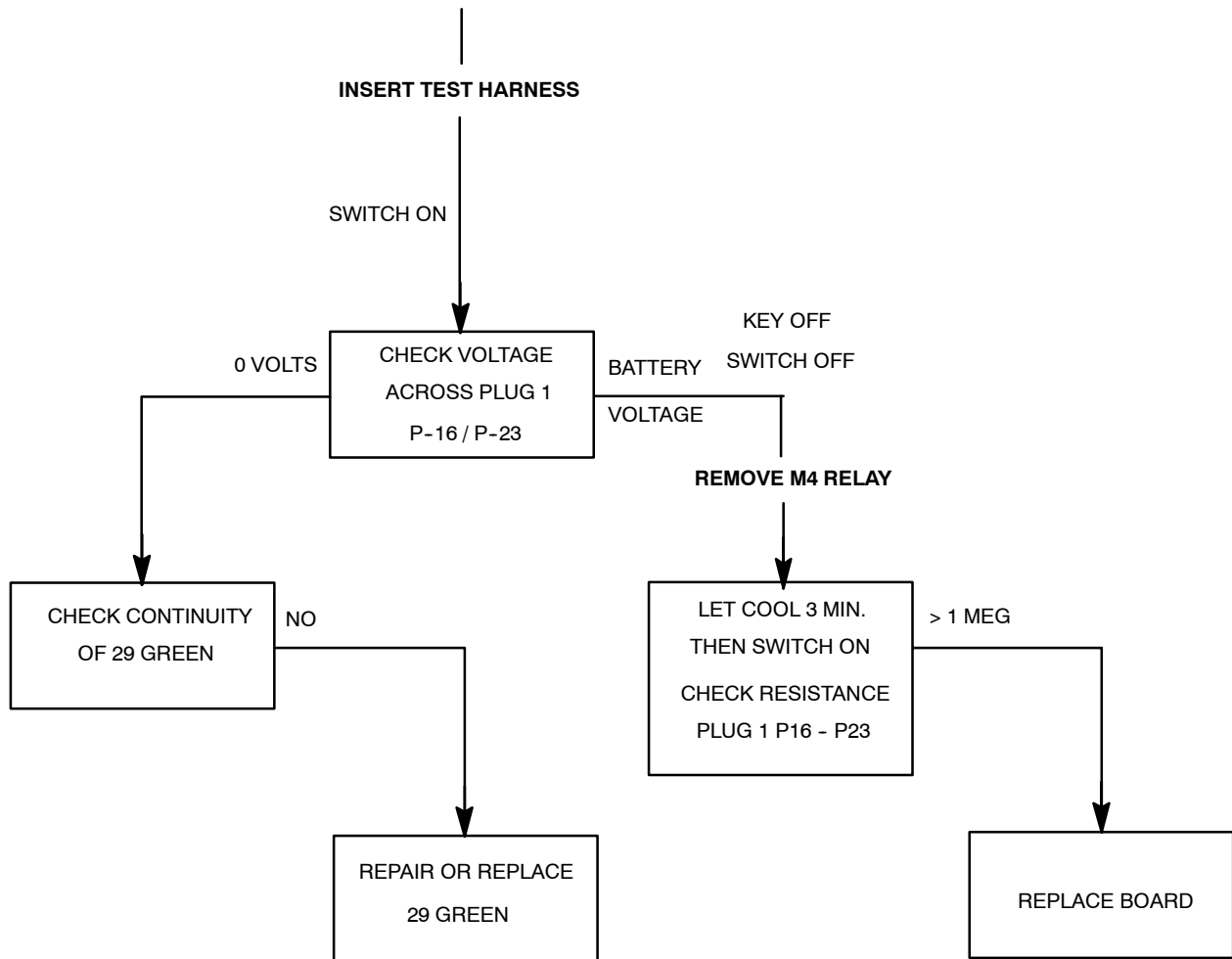

ELECTRICAL

VAC FAN

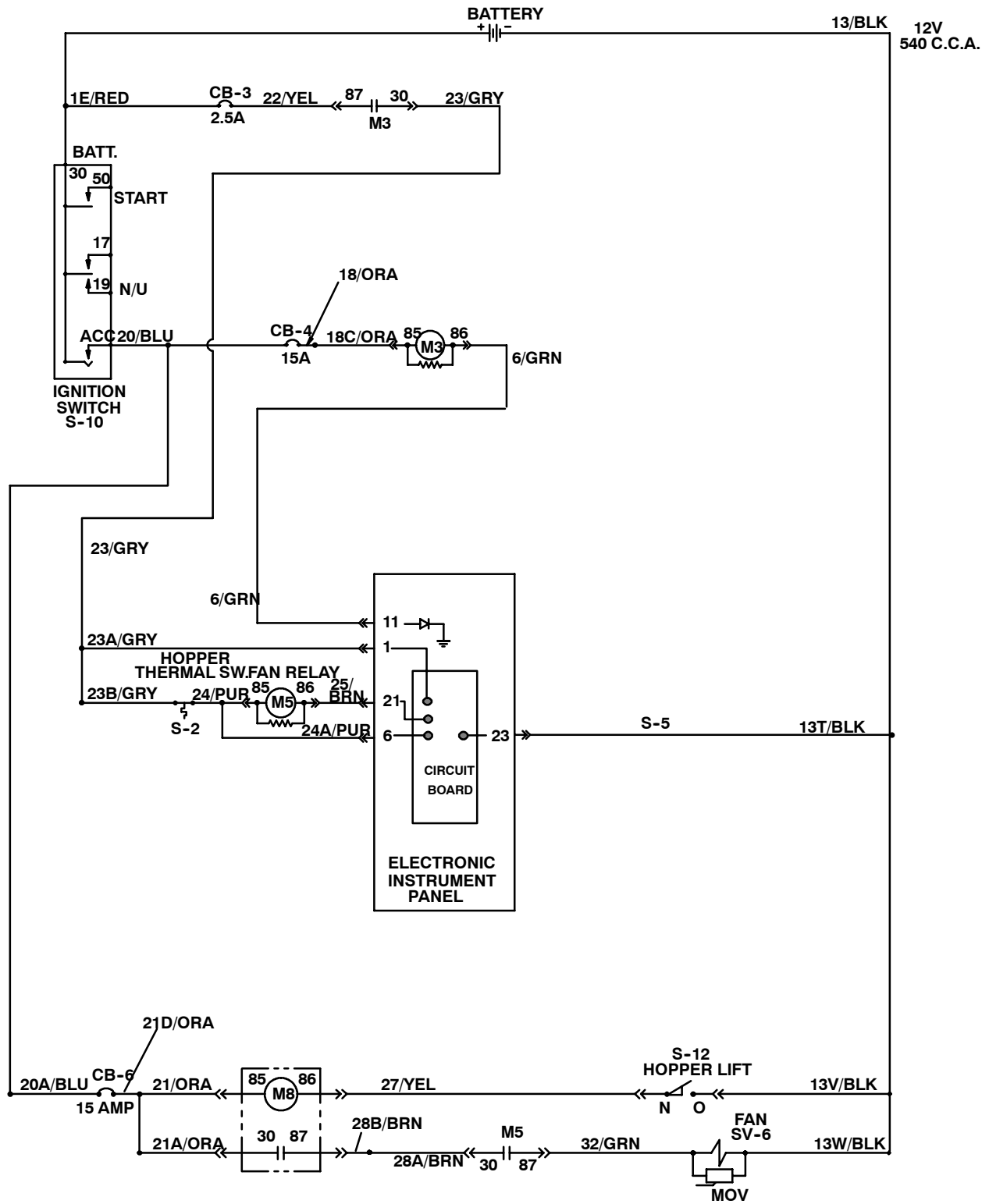

VACUUM FAN FAILURE

TEST ASSUMES VAC FAN SWITCH IS ACTIVATED UNLESS KEY IS OFF.
 RESETTING SWITCH WILL BE NECESSARY.

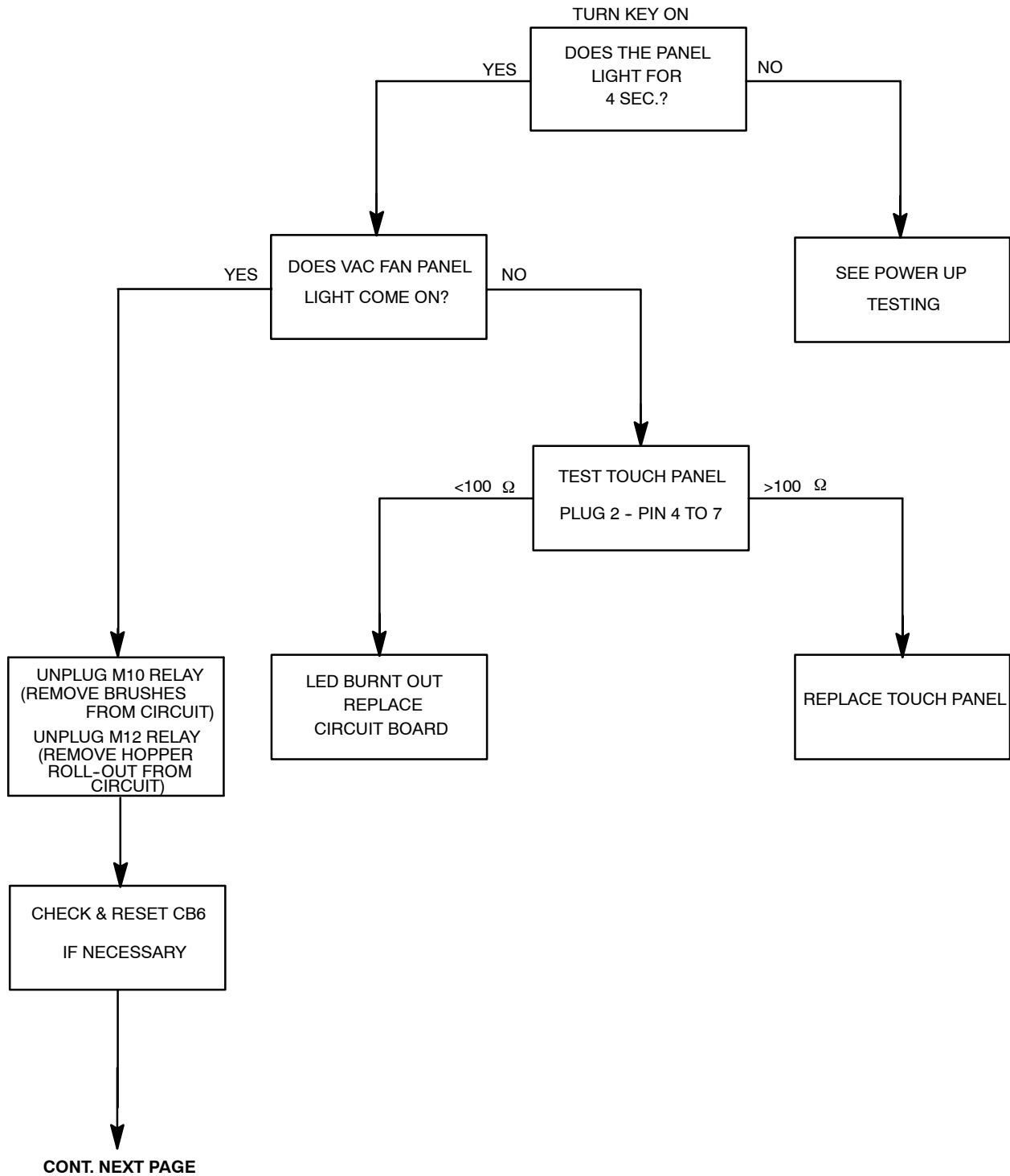

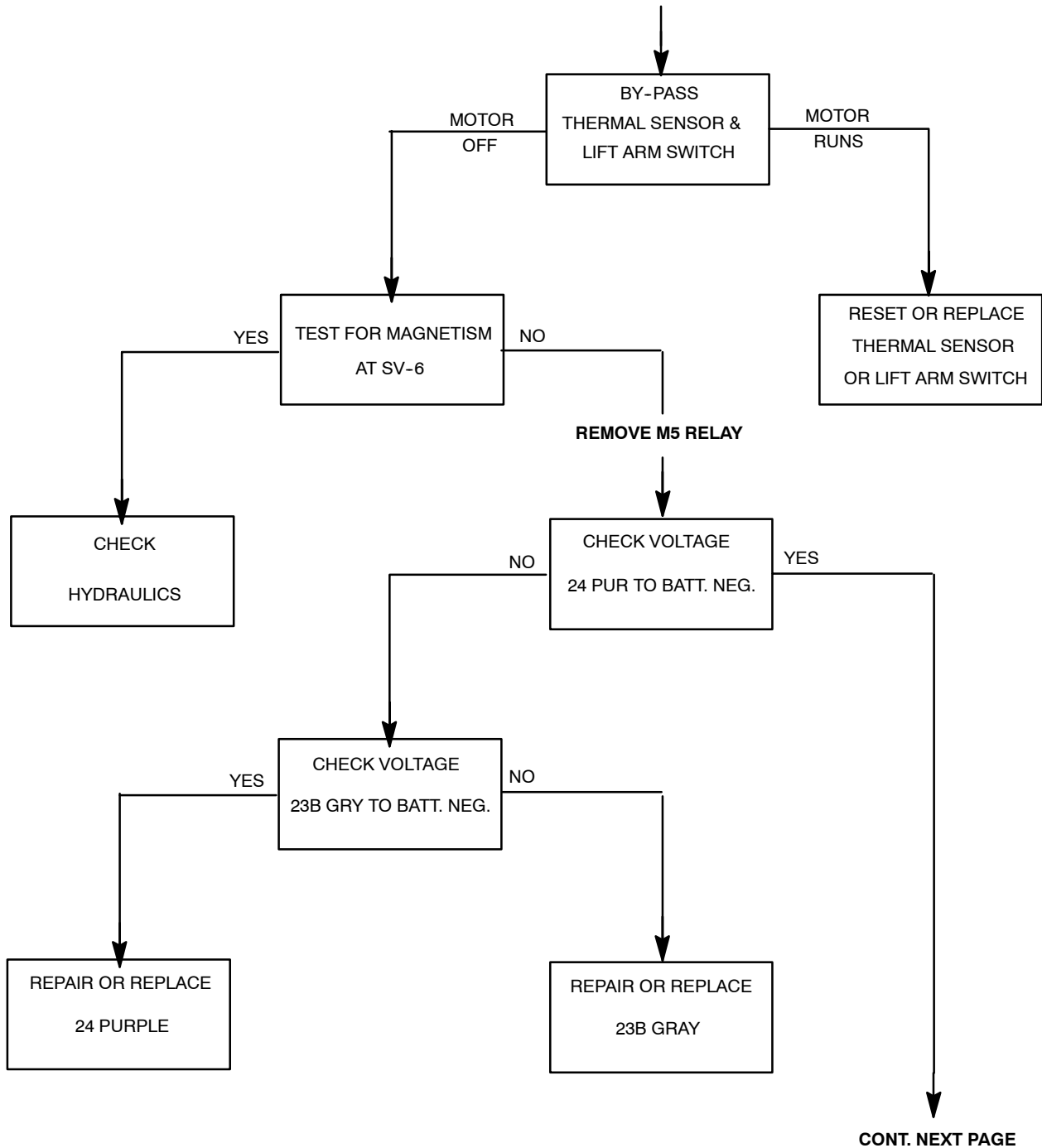

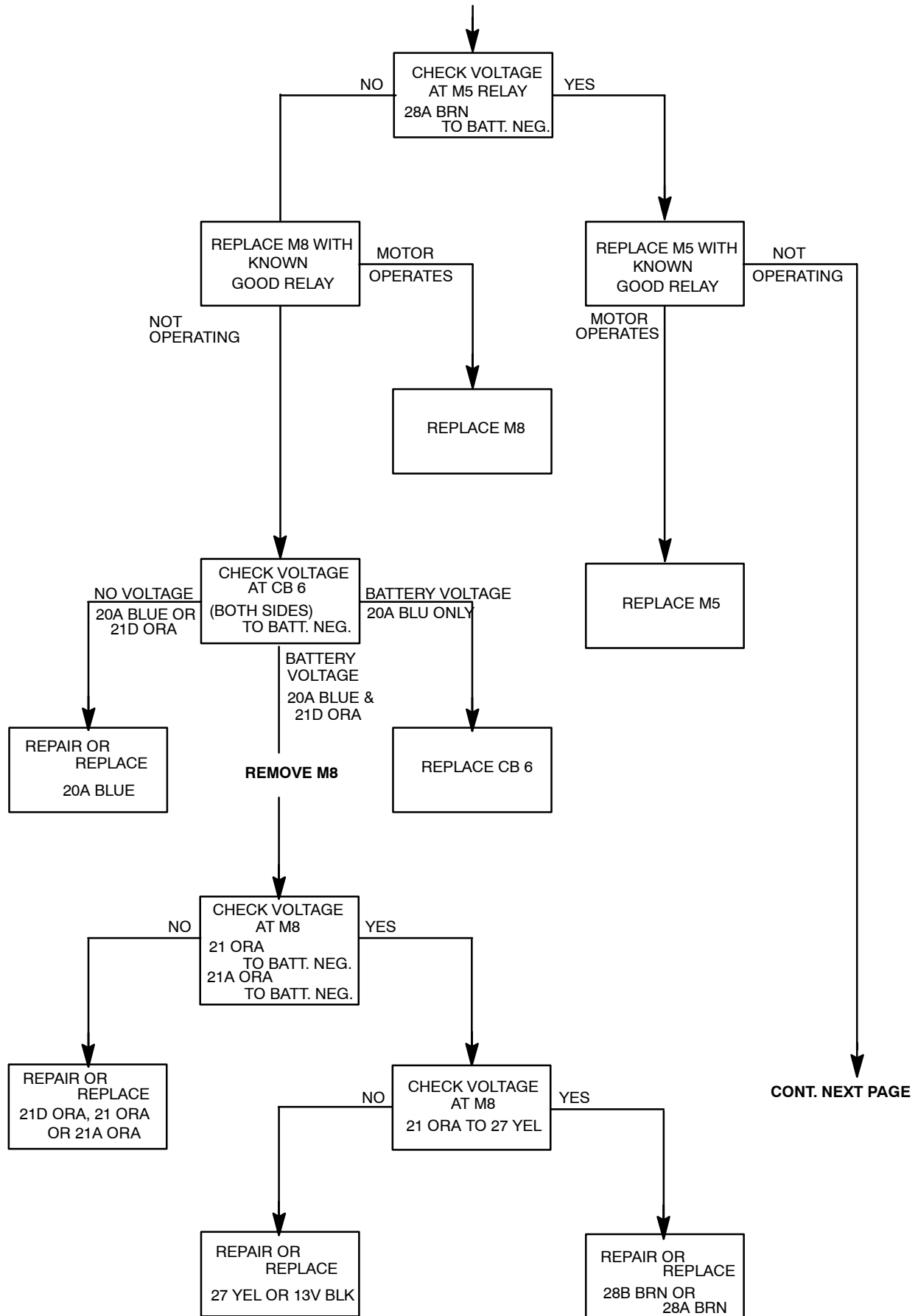

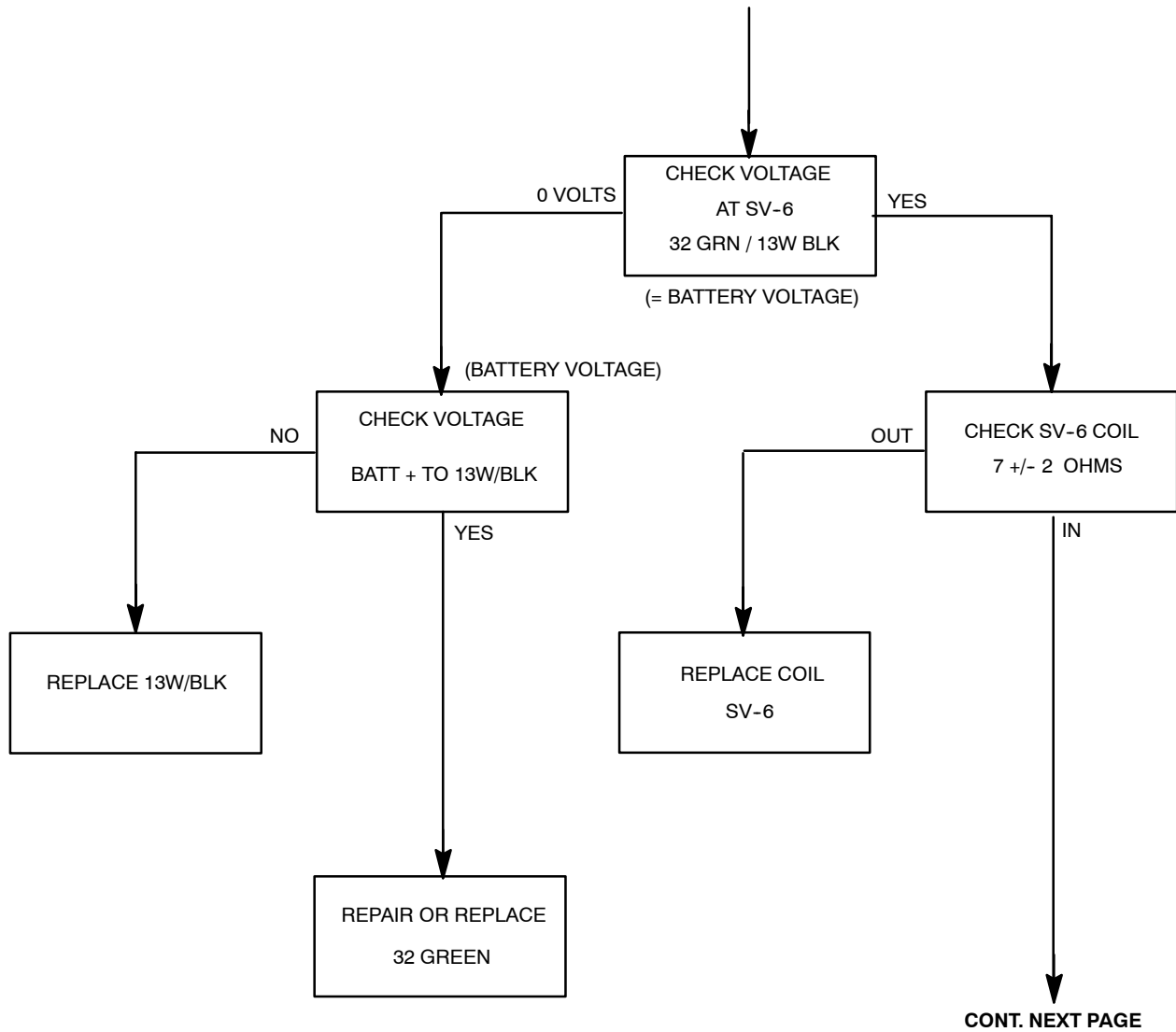

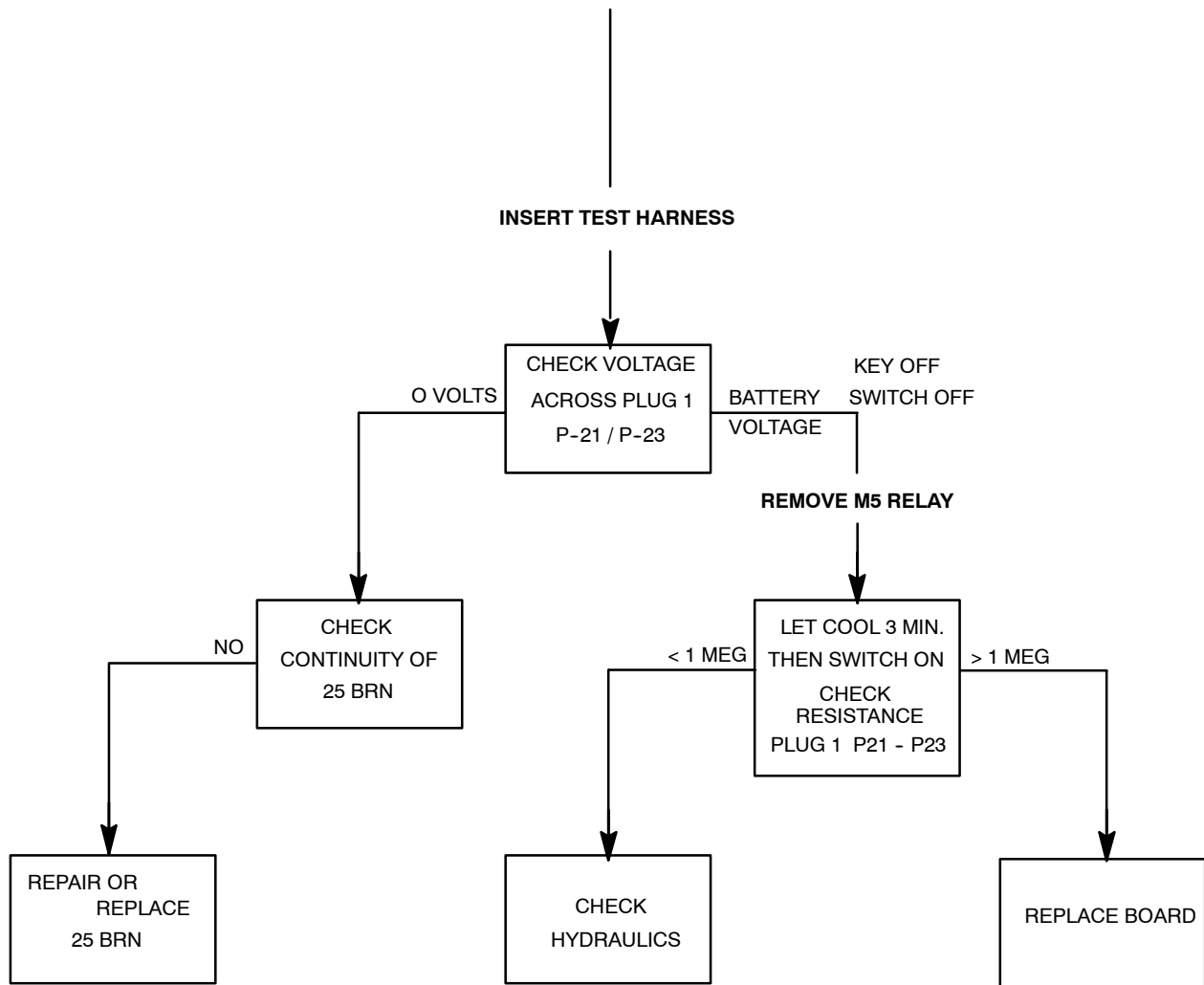

ELECTRICAL

MAIN BRUSH

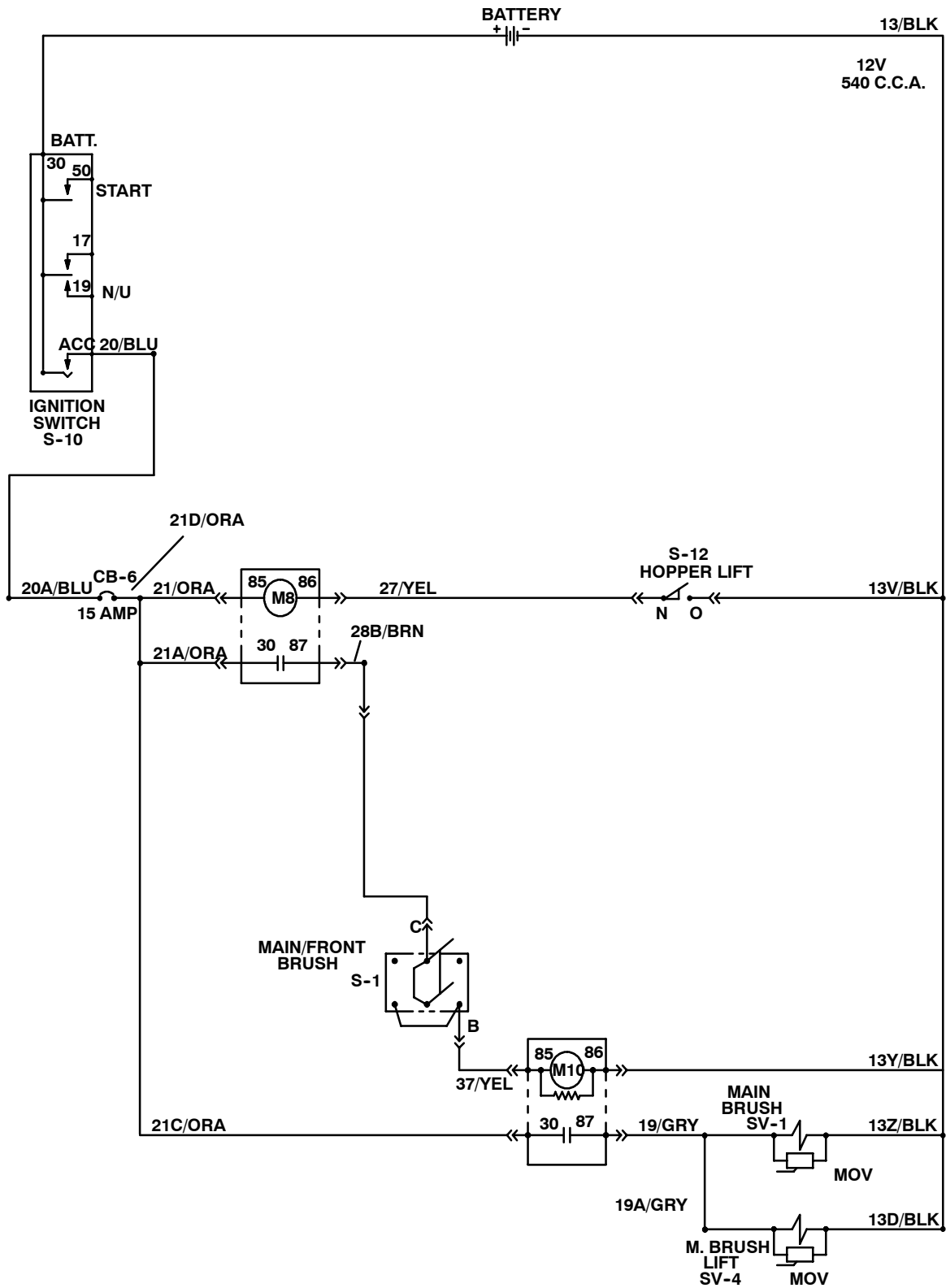

MAIN BRUSH FAILURE

(VAC FAN WORKS)

TEST ASSUMES MAIN BRUSH SWITCH IS ACTIVATED UNLESS KEY IS OFF.
 RESETTING SWITCH WILL BE NECESSARY.

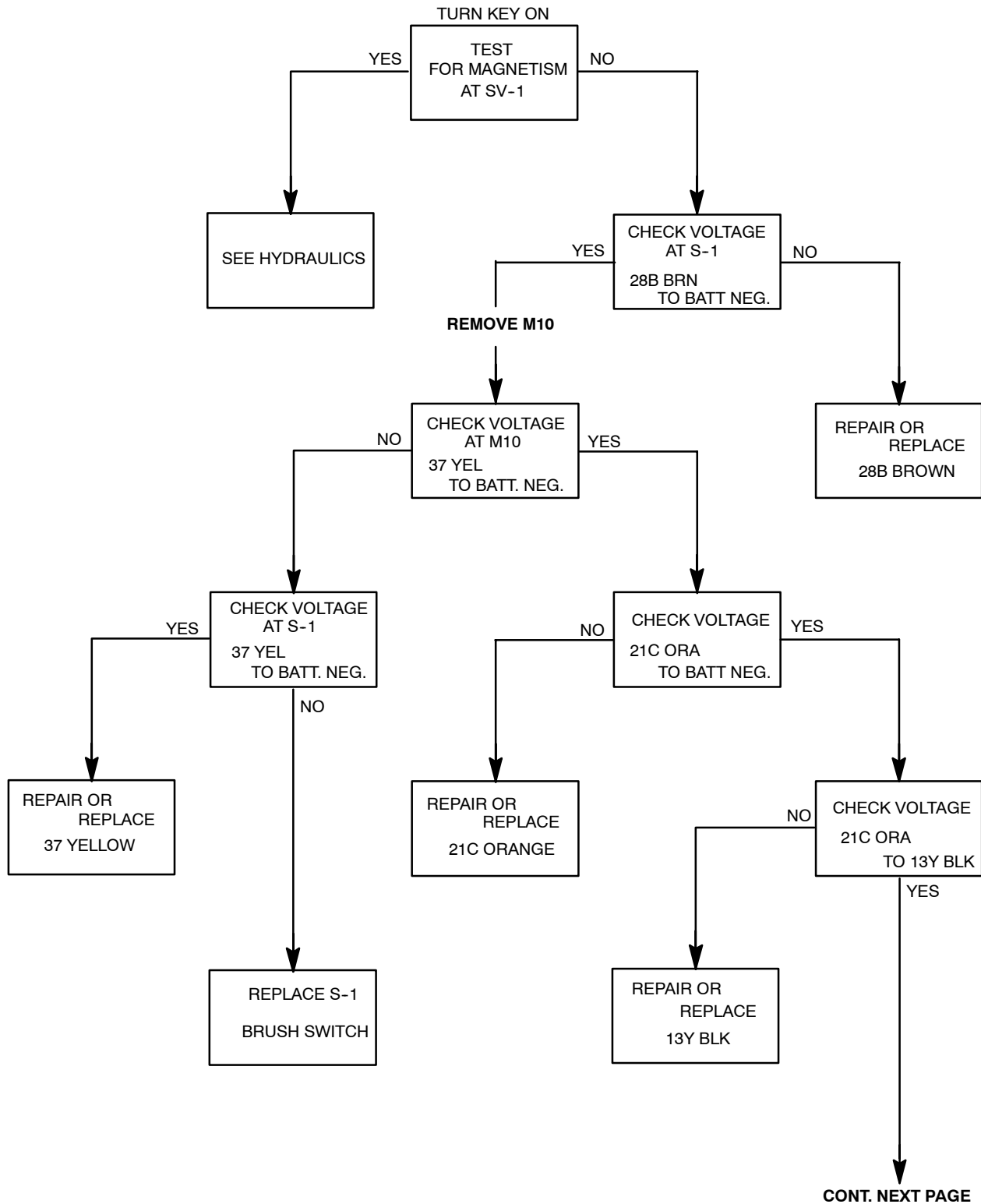

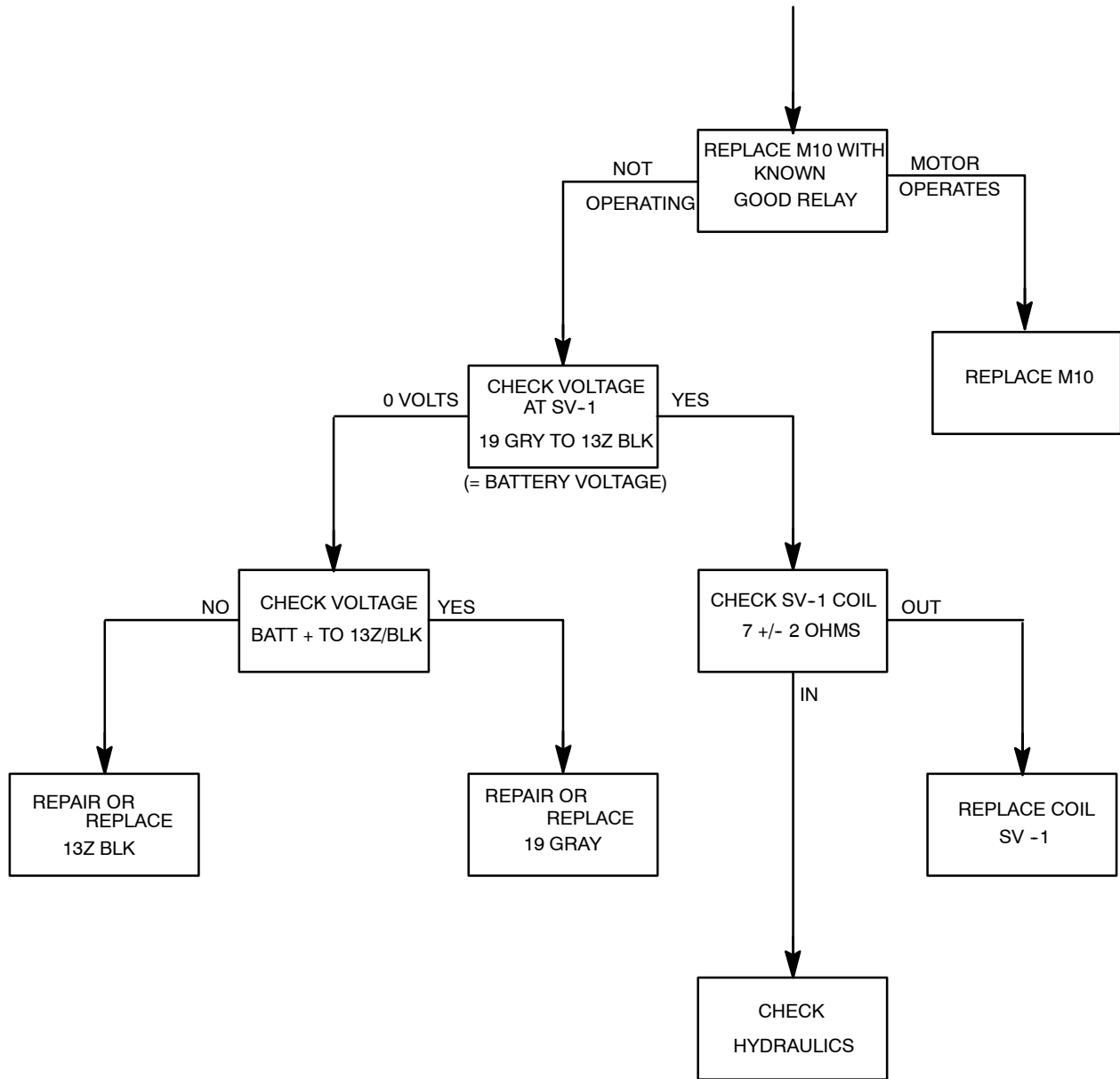

SIDE BRUSH

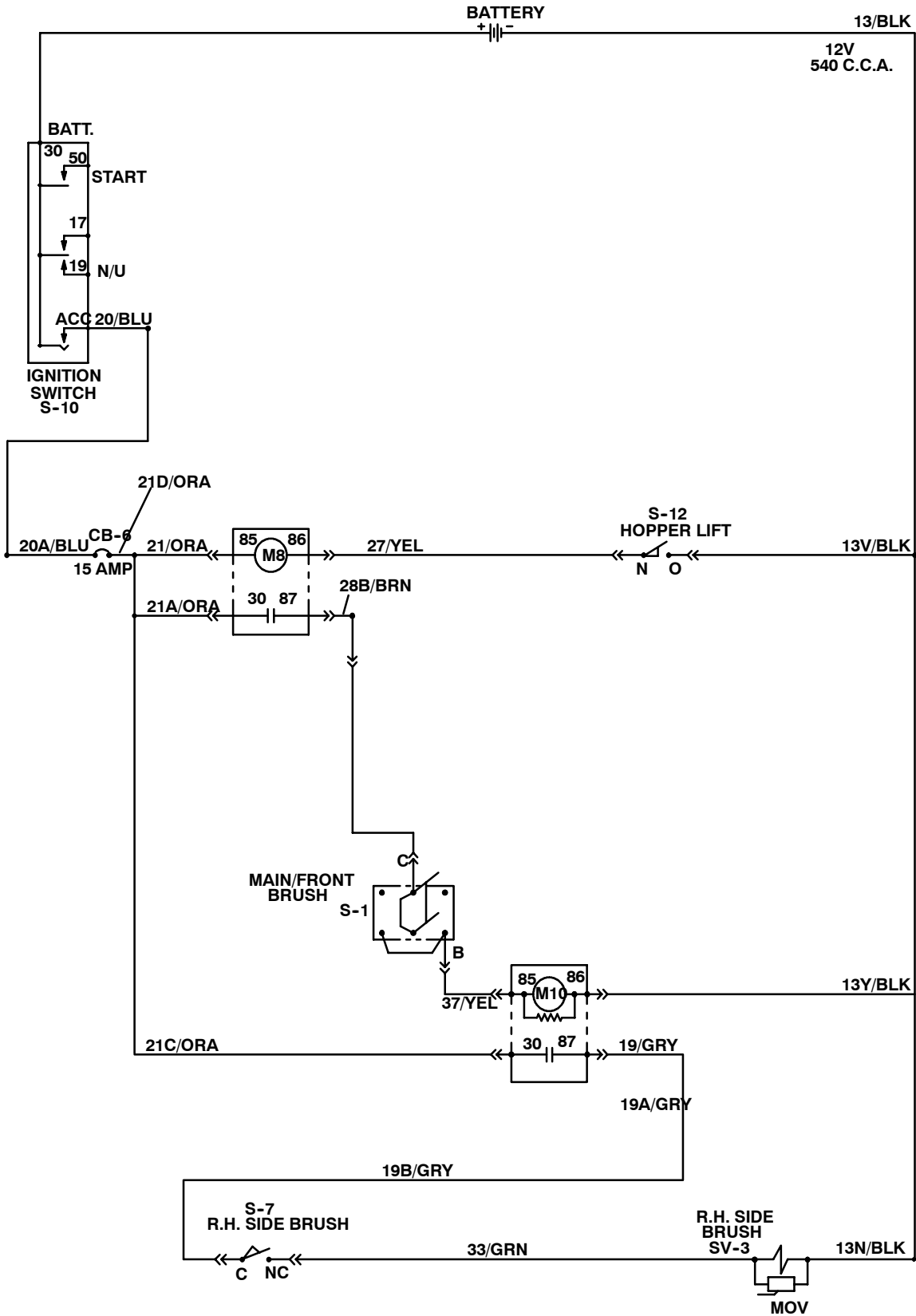

ELECTRICAL

SIDE BRUSH FAILURE

(MAIN BRUSH WORKS)

TEST ASSUMES SIDE BRUSH LEVER IS ENGAGED.

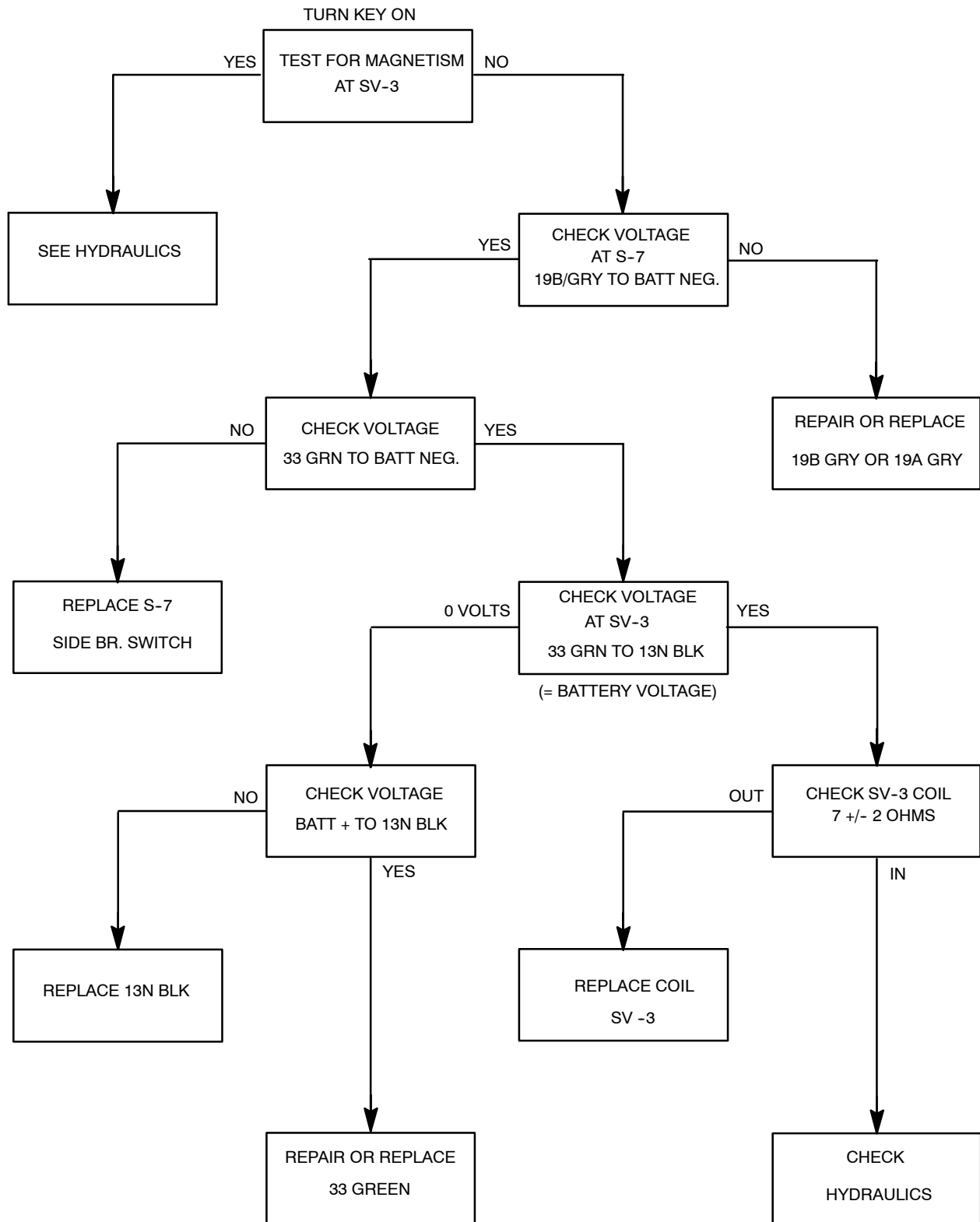

HOPPER ROLL OUT

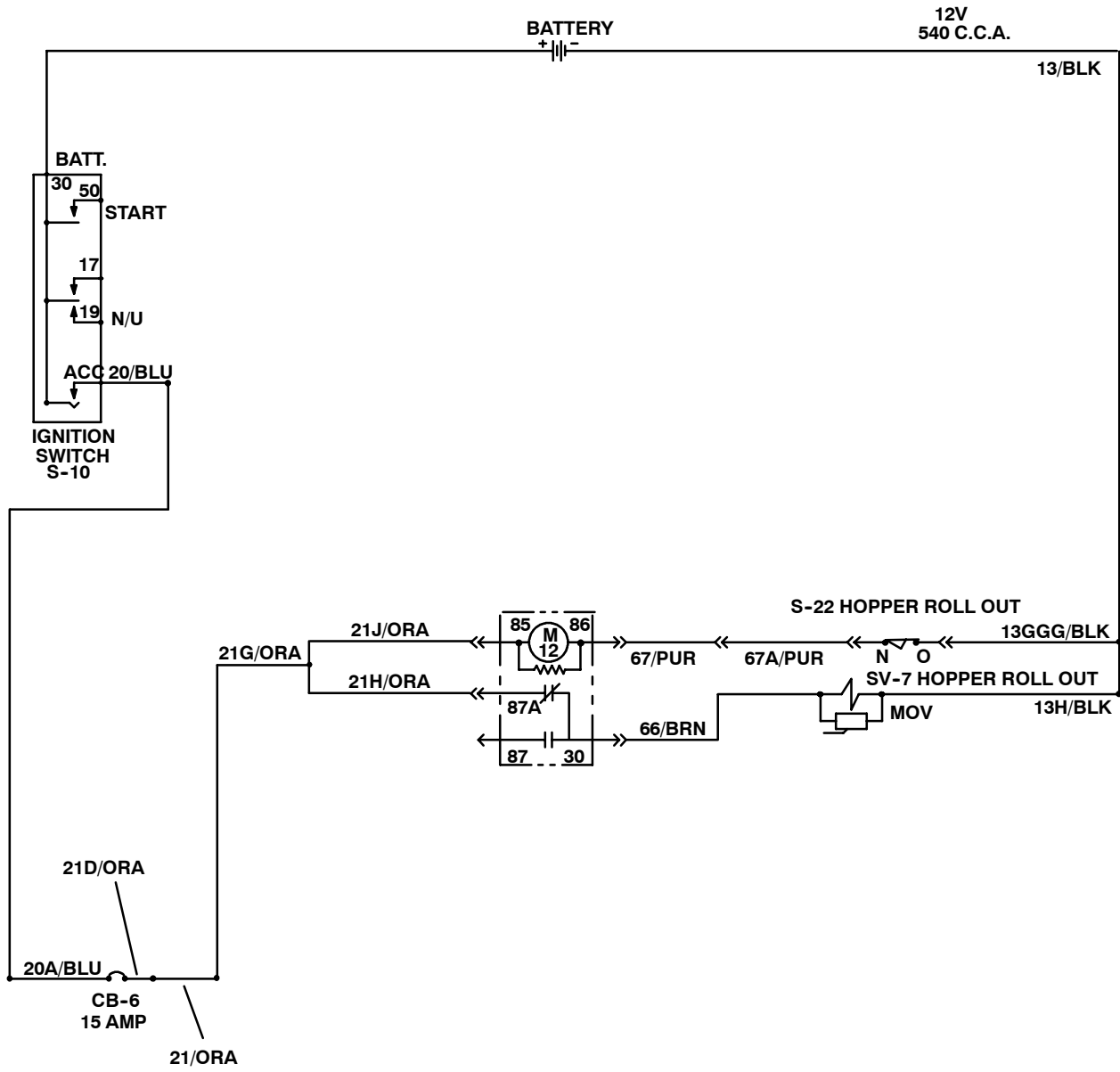

HOPPER ROLLOUT FAILURE

(NO REDUCED CYLINDER SPEED)

(HOPPER IS FULLY RAISED AND ROLLED OUT)

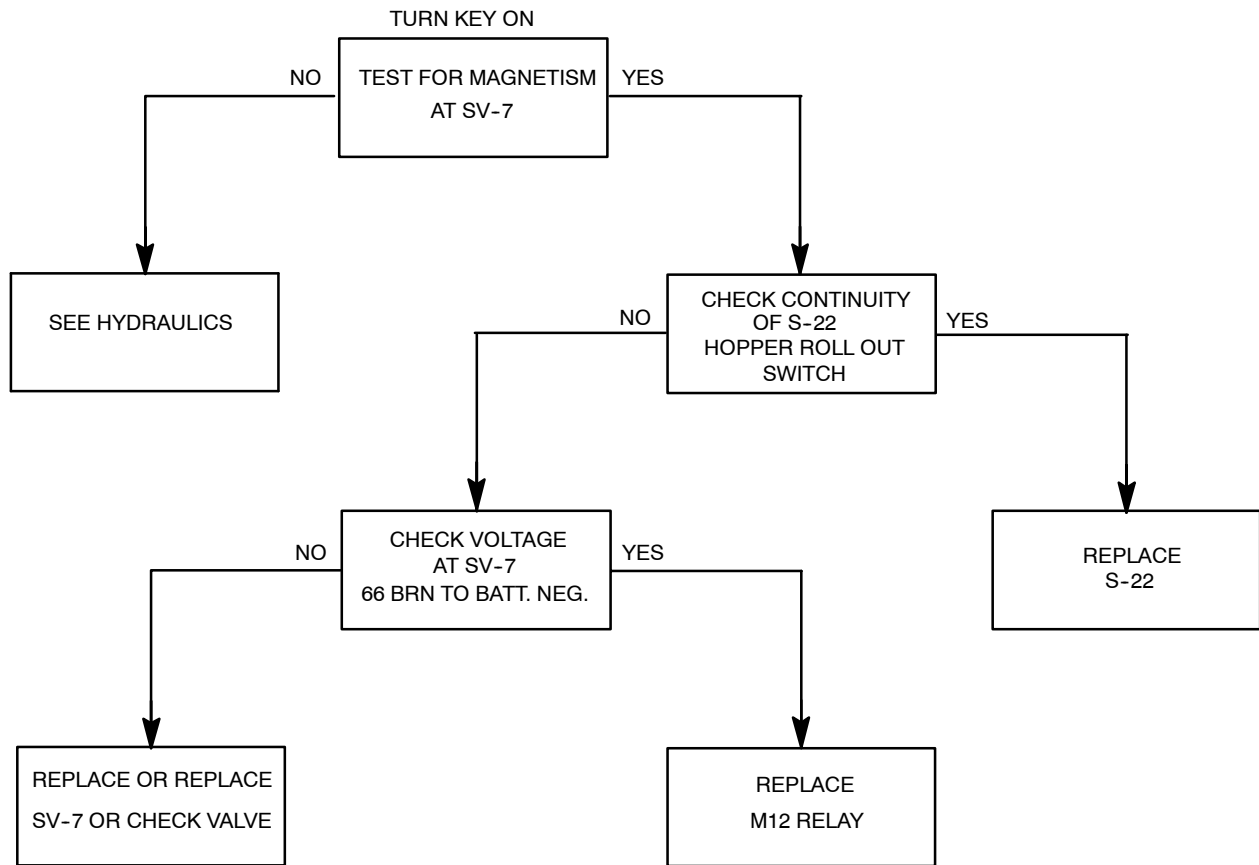

HEADLIGHT

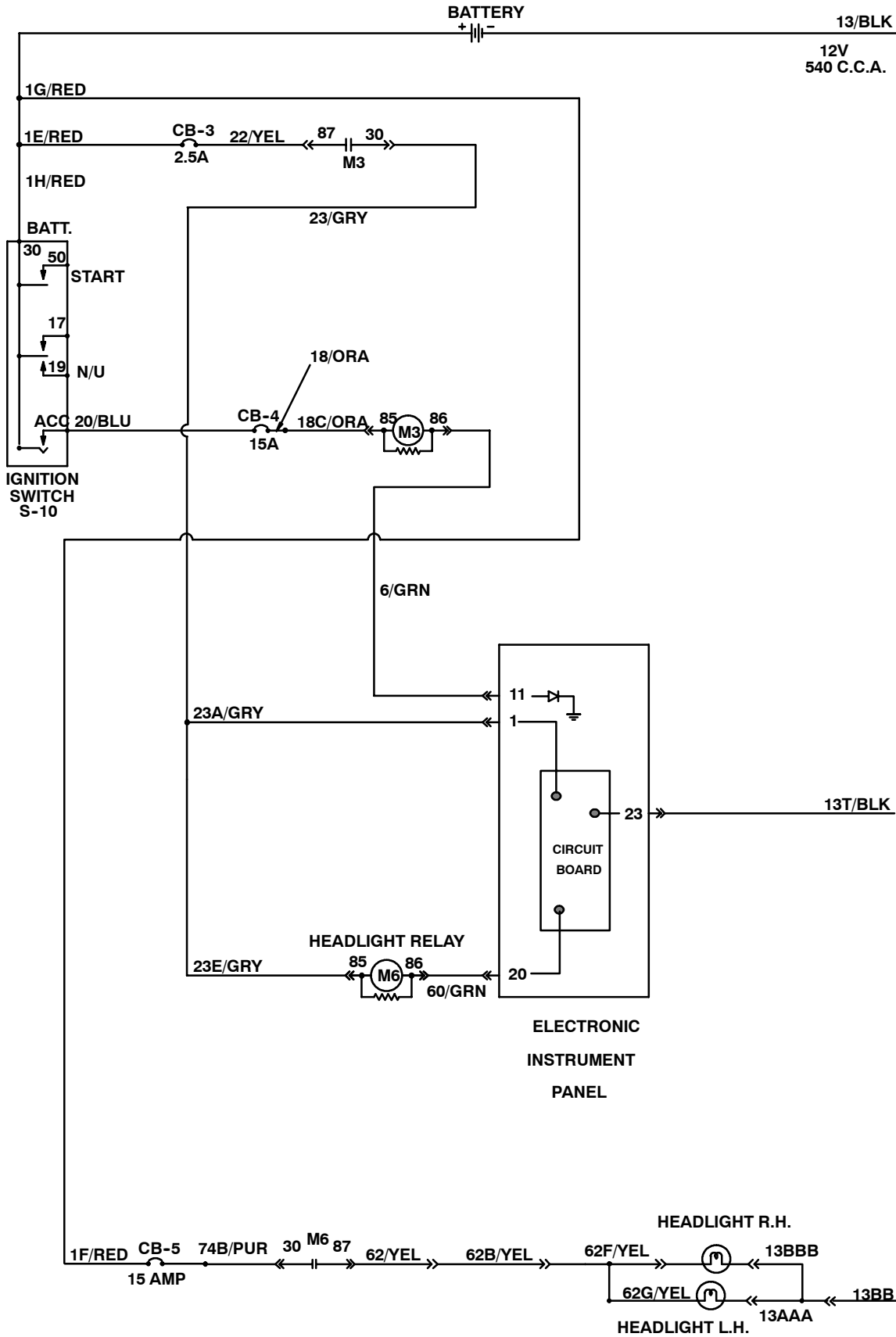

HEADLIGHT FAILURE

TEST ASSUMES HEADLIGHT SWITCH IS ACTIVATED UNLESS KEY IS OFF.

RESETTING SWITCH WILL BE NECESSARY.

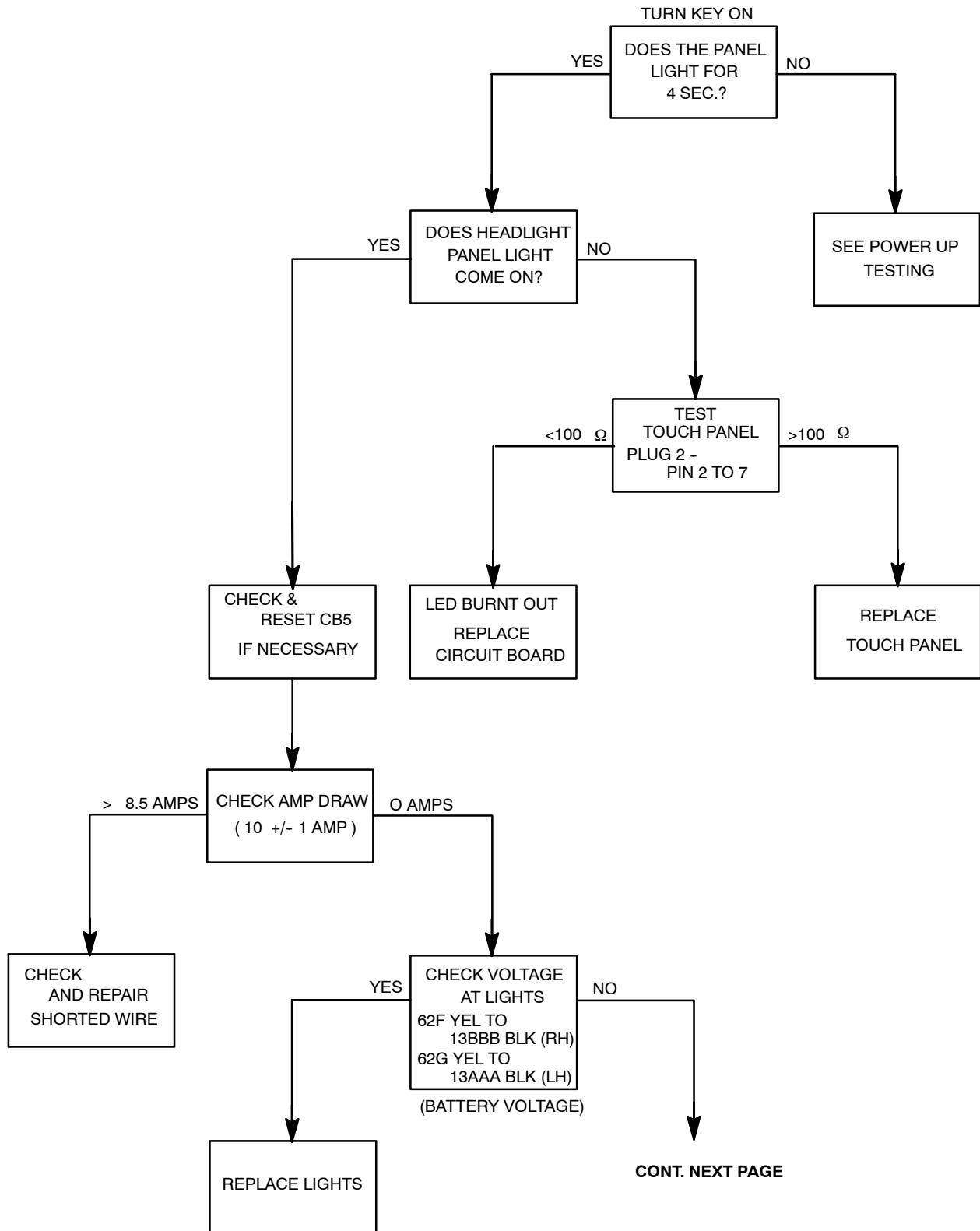

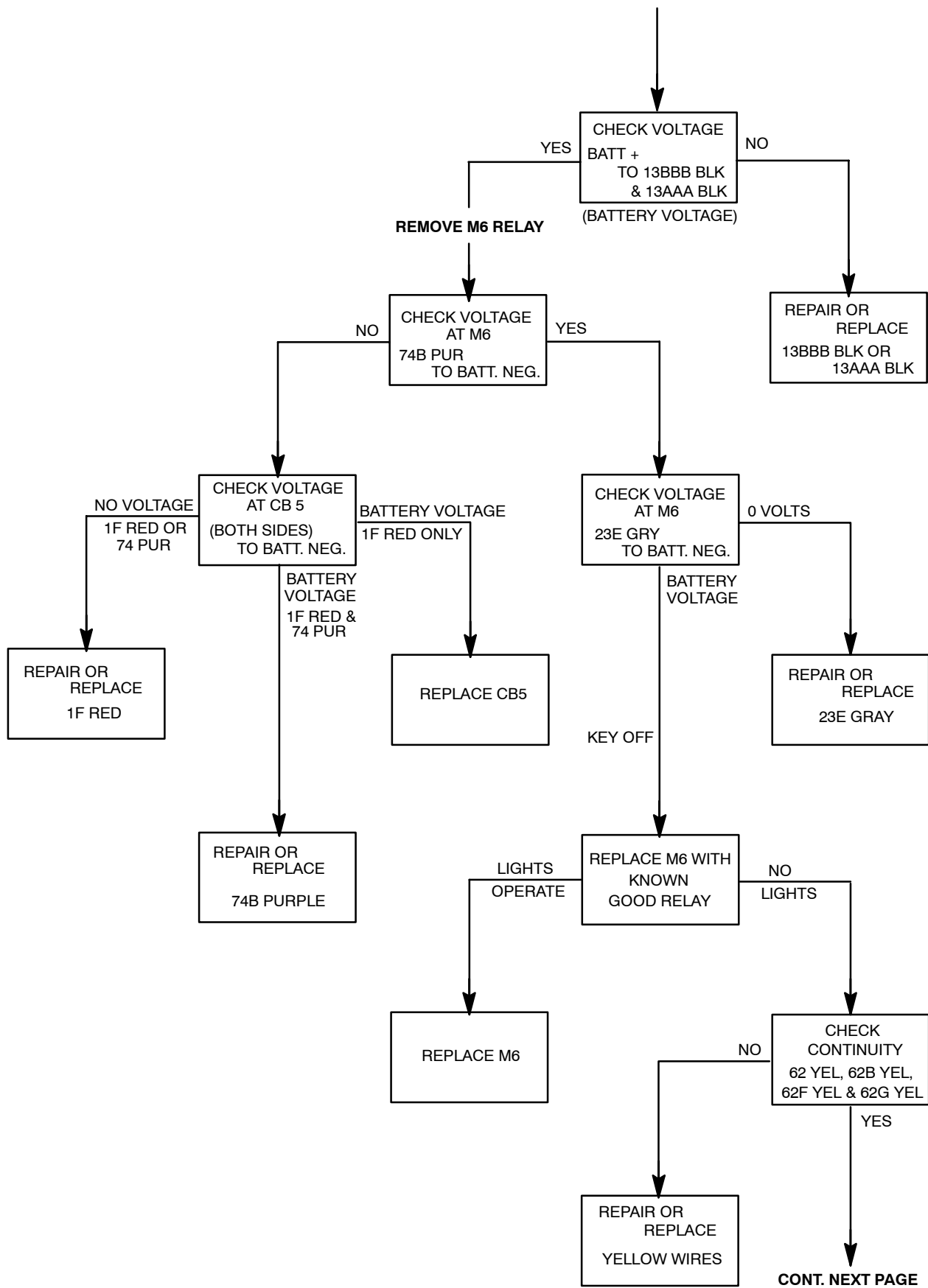

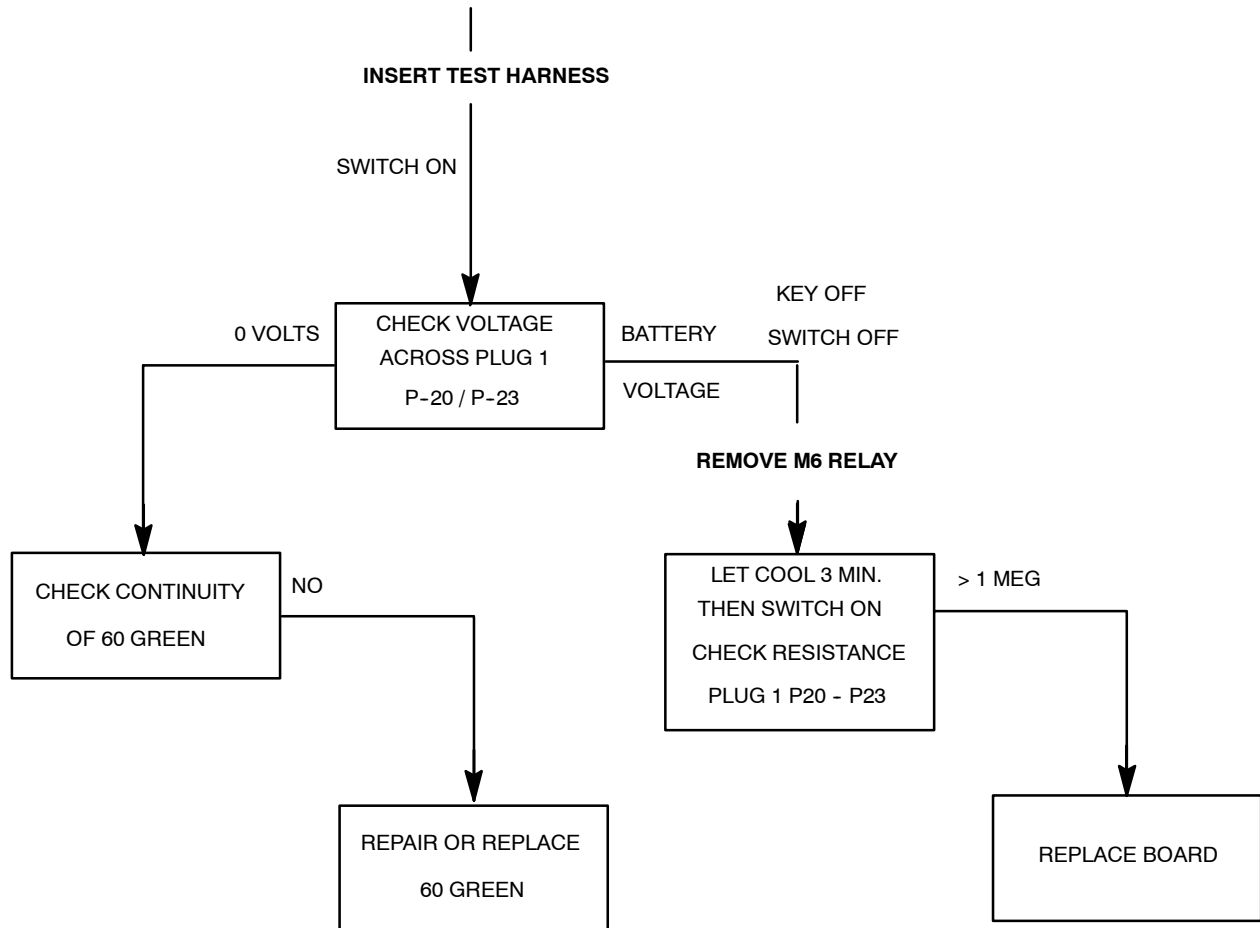

WARNING LIGHT

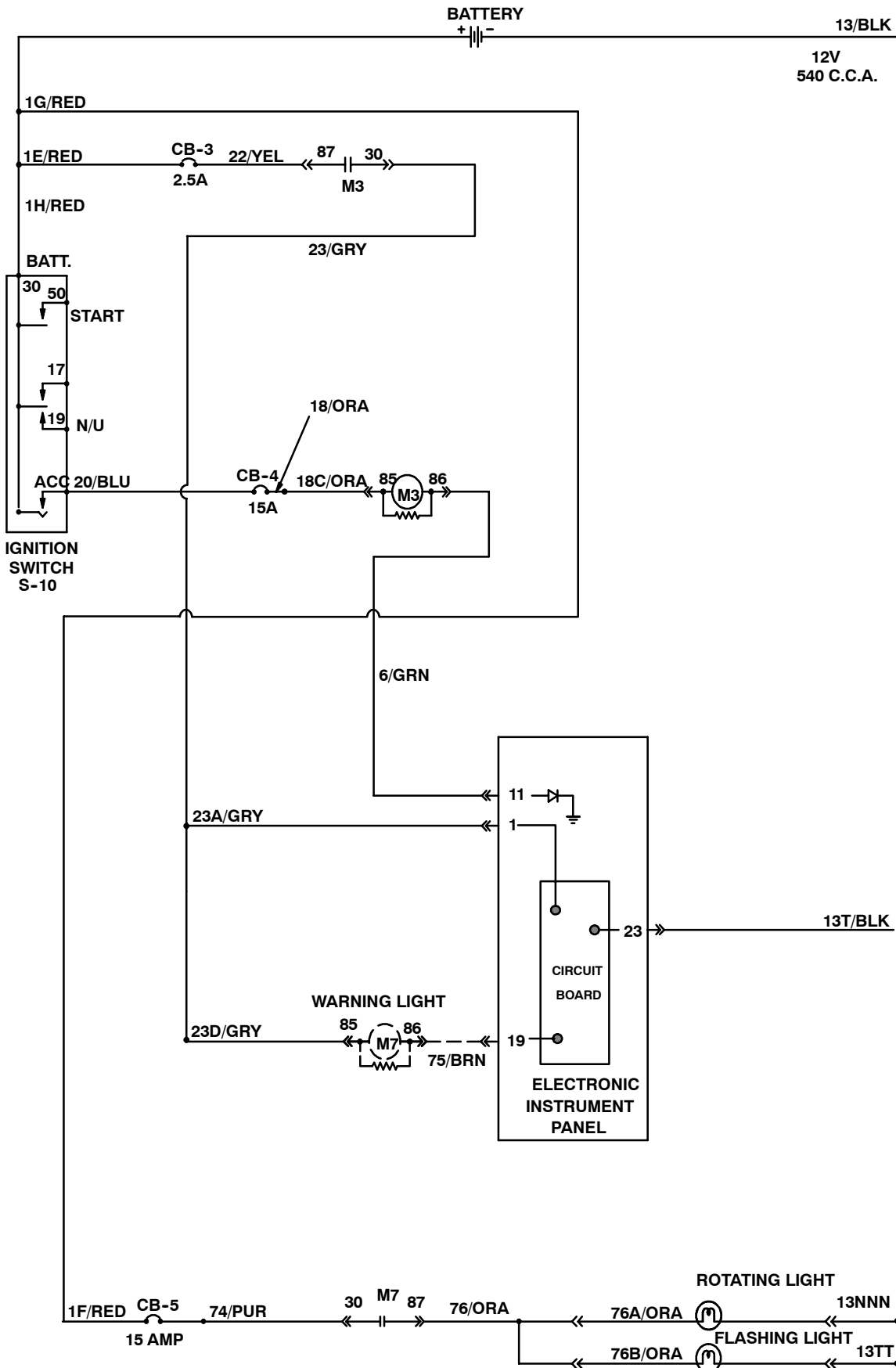

WARNING LIGHT FAILURE

TEST ASSUMES HAZARD LIGHT SWITCH IS ACTIVATED UNLESS KEY IS OFF.

RESETTING SWITCH WILL BE NECESSARY.

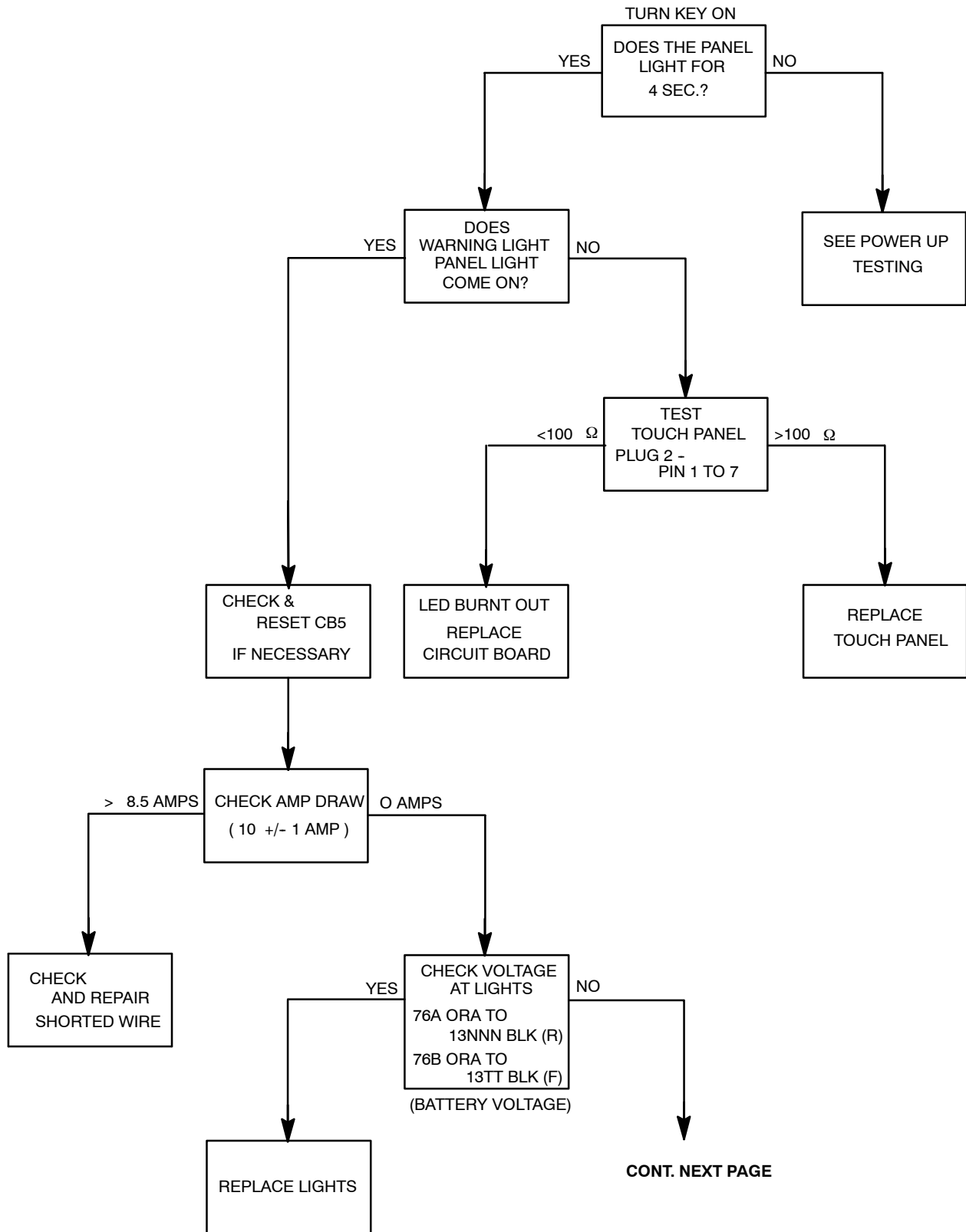

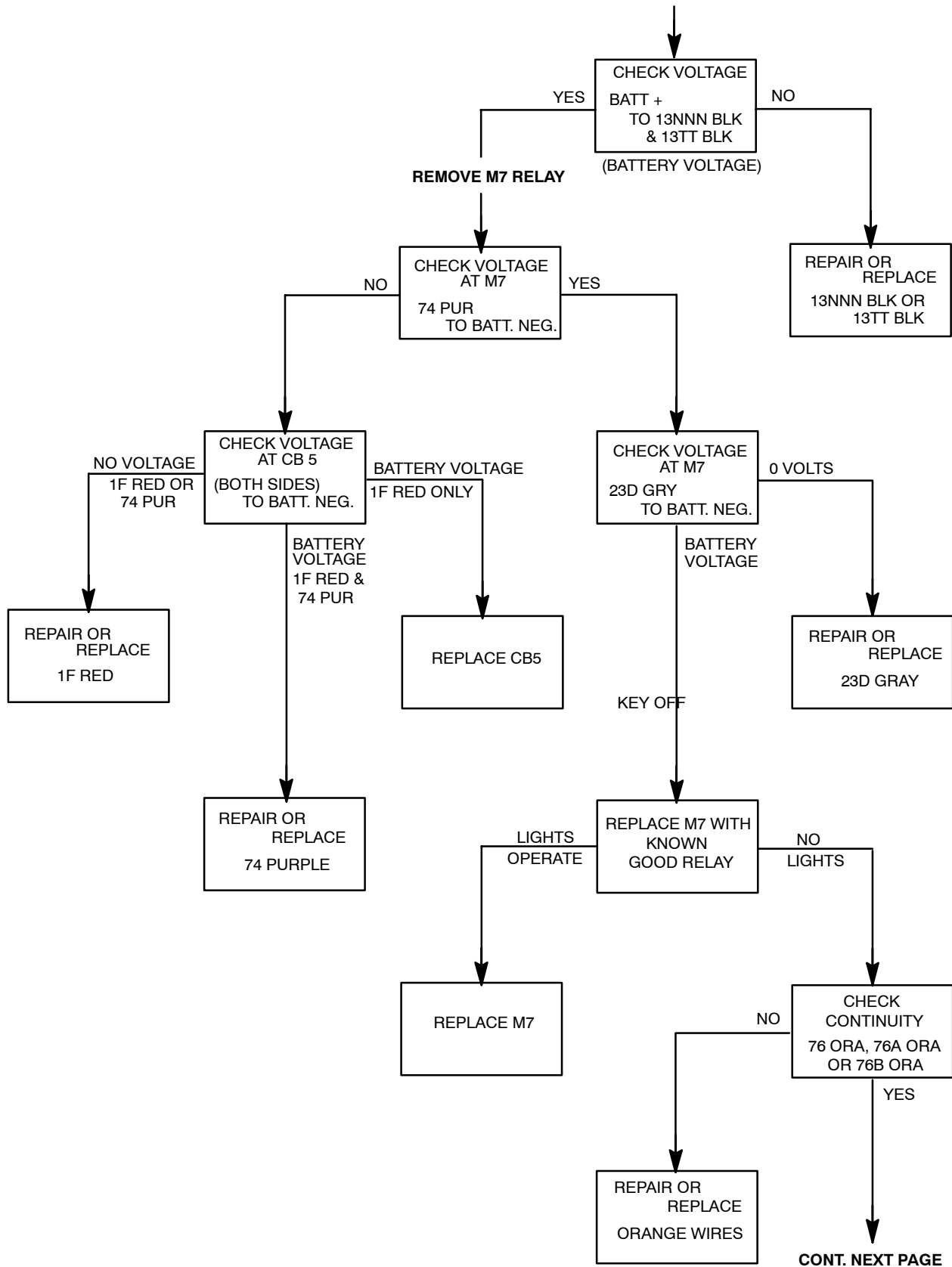

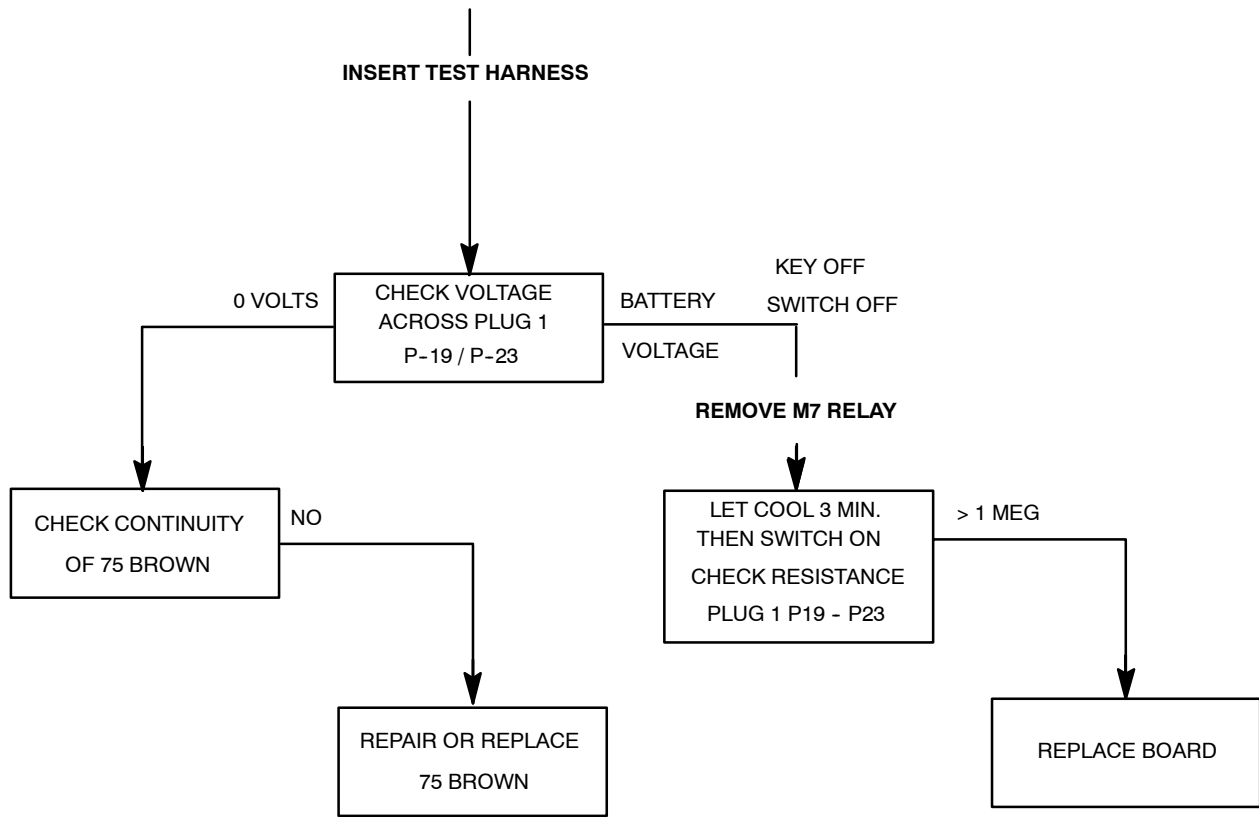

CLOGGED FILTER INDICATOR

LIGHT WILL NOT COME ON

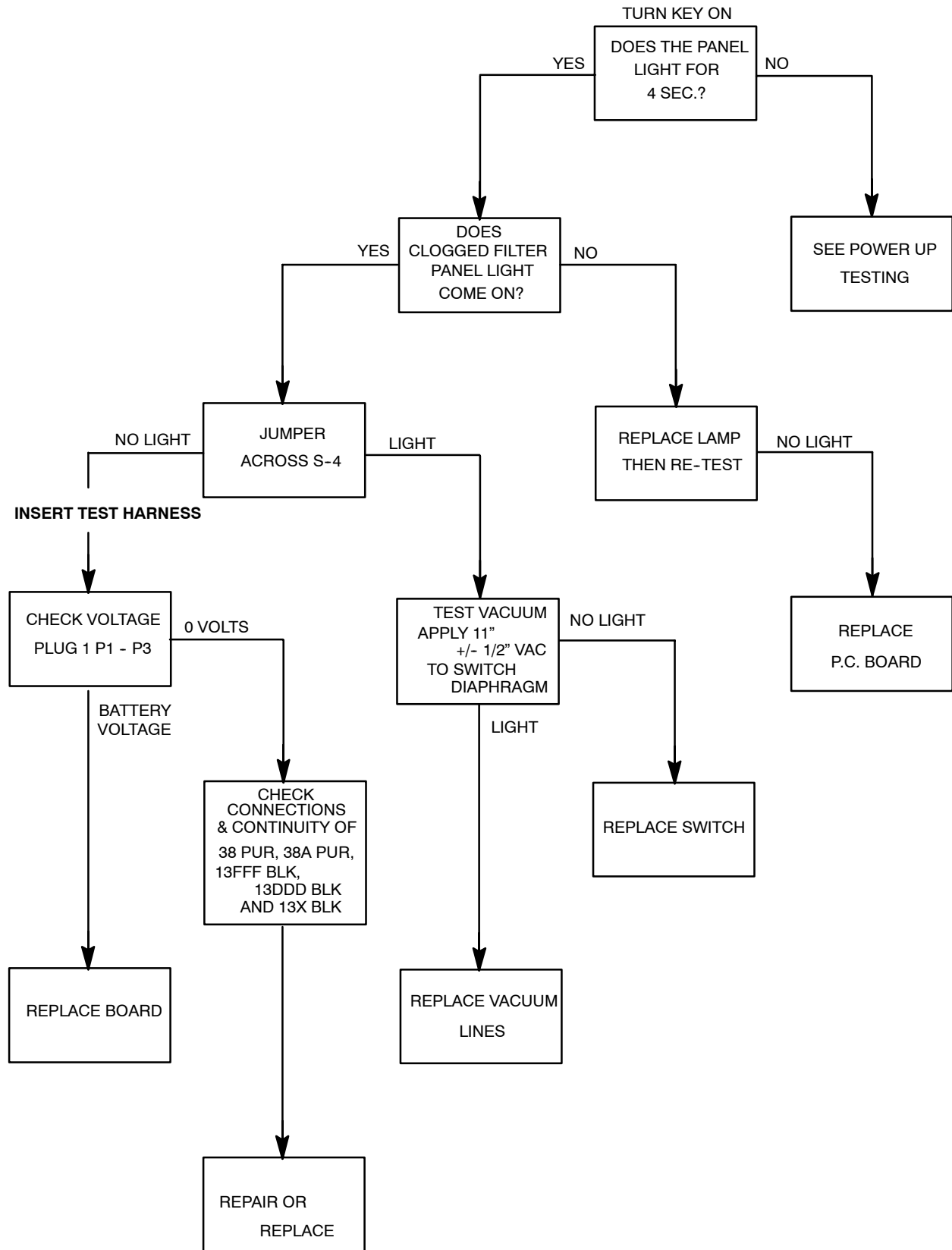

HOPPER DOOR CIRCUIT

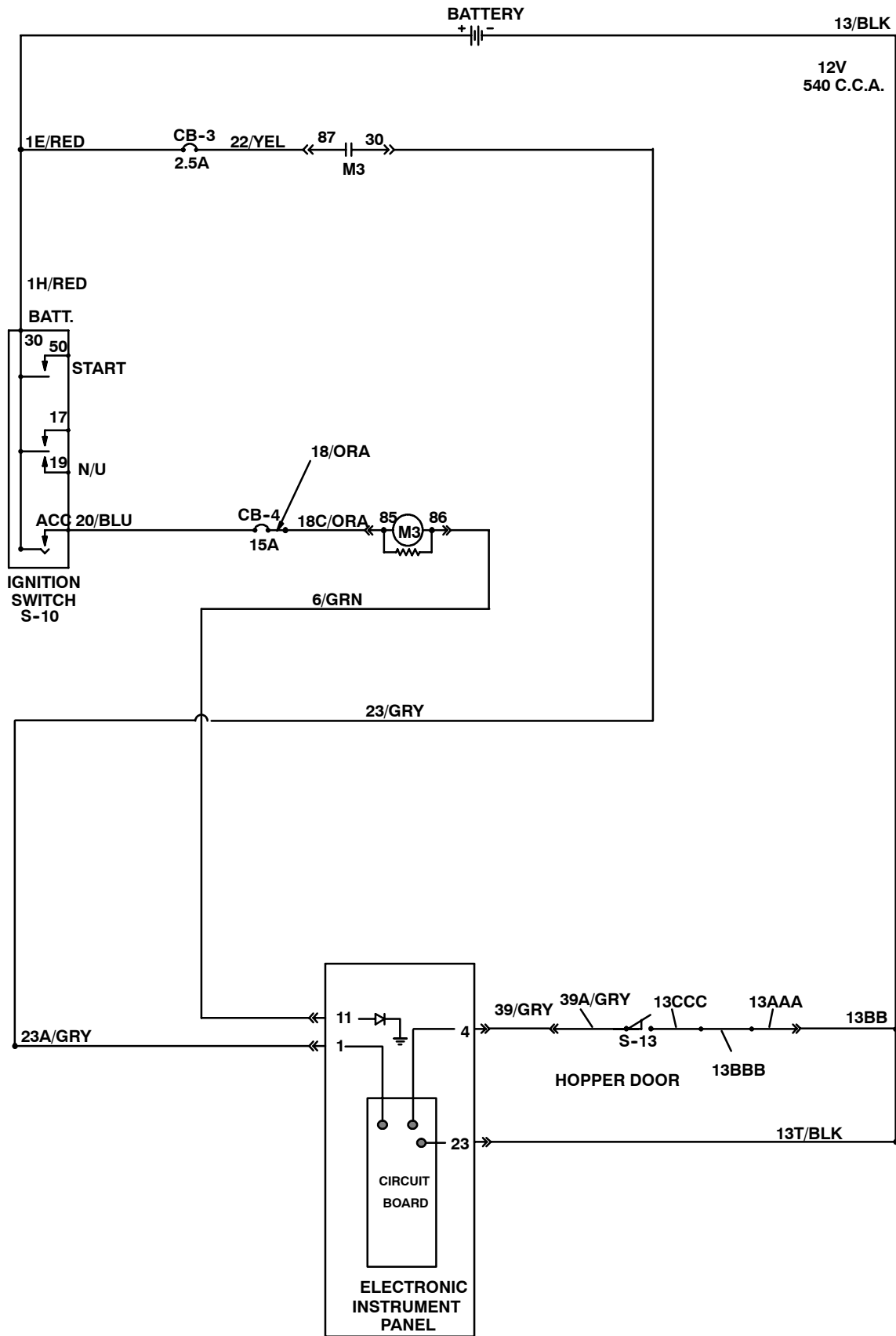

HOPPER DOOR INDICATOR

LIGHT WILL NOT COME ON

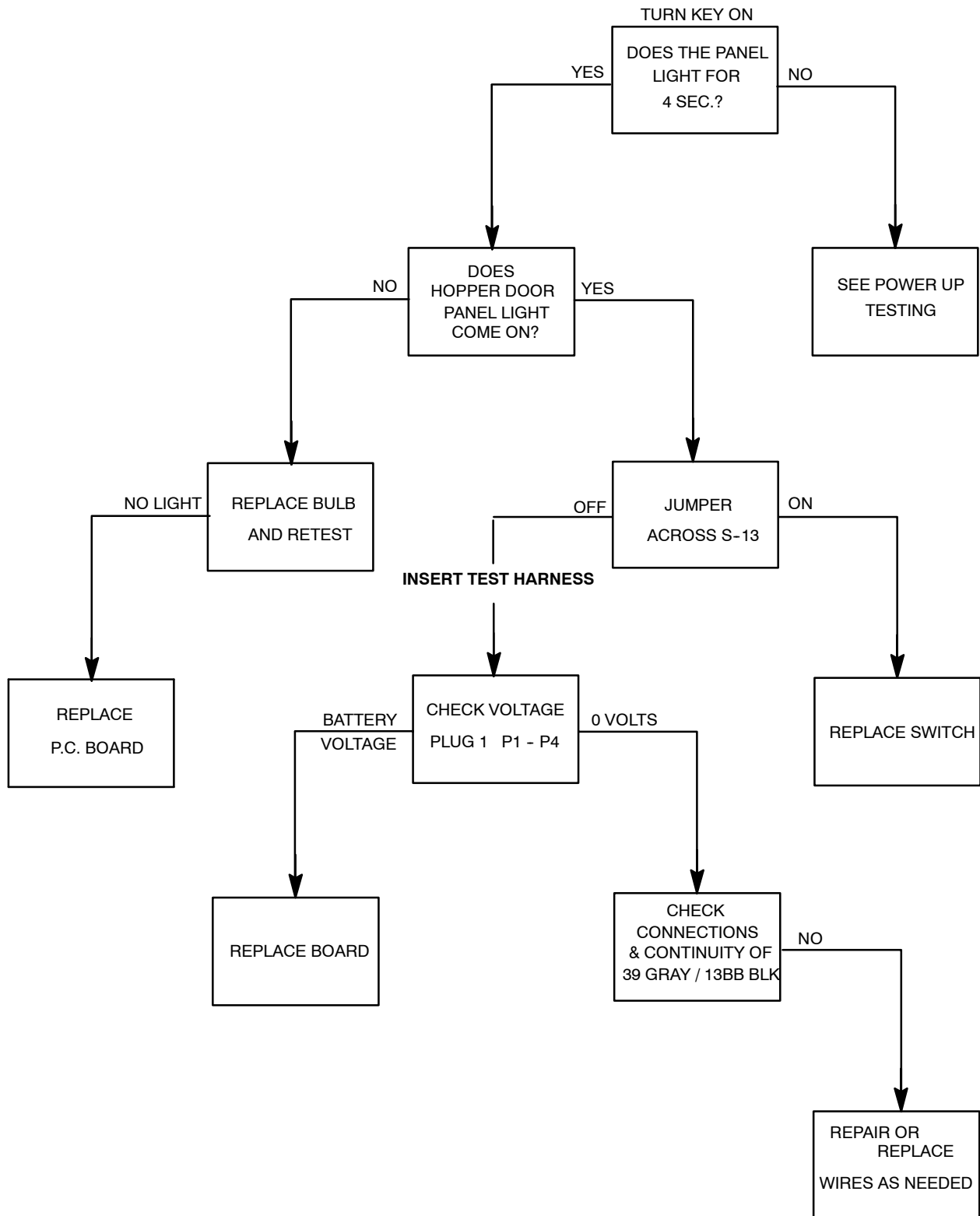

DOWN FORCE

LIGHT WILL NOT COME ON

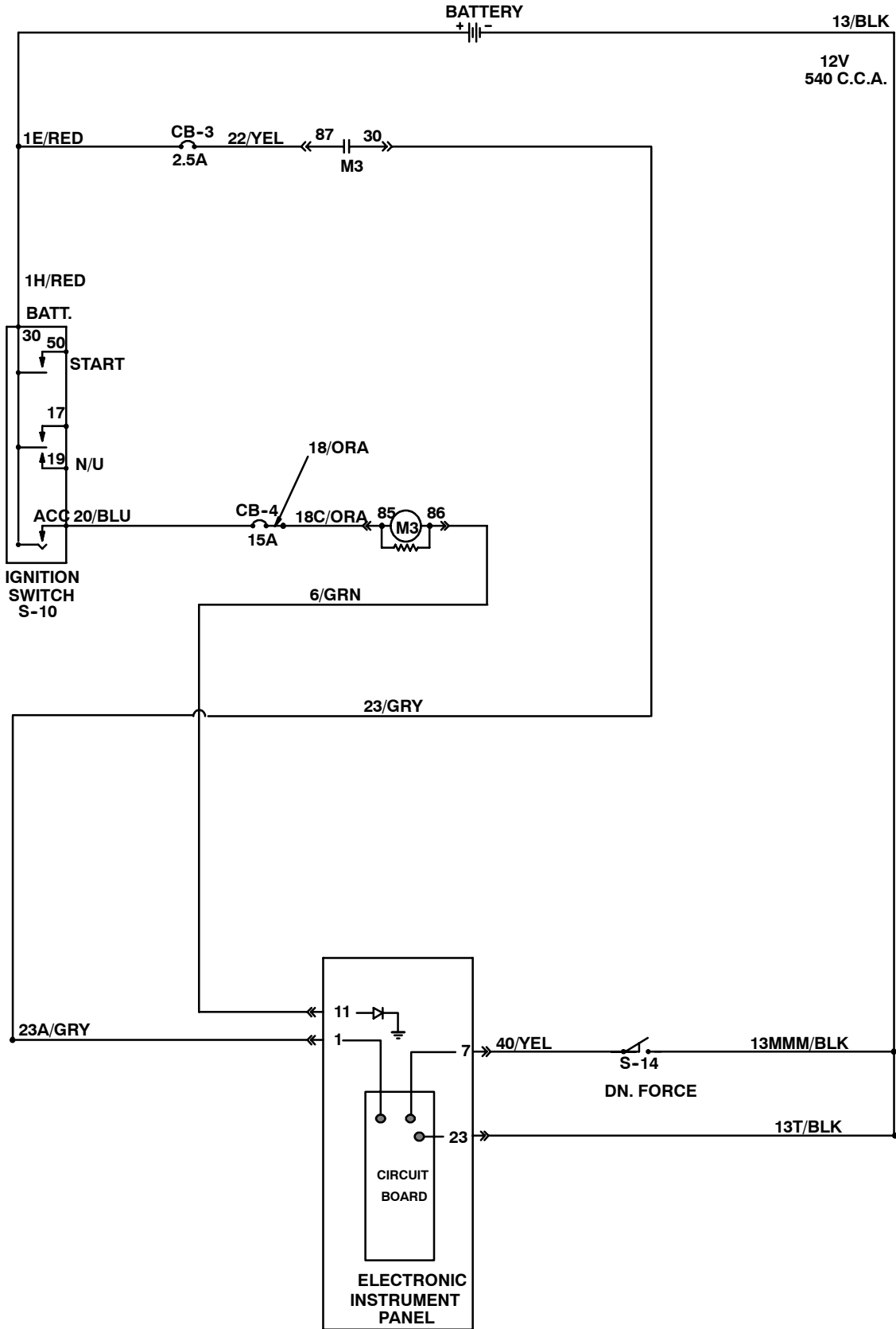

DOWN FORCE CIRCUIT

LIGHT WILL NOT COME ON

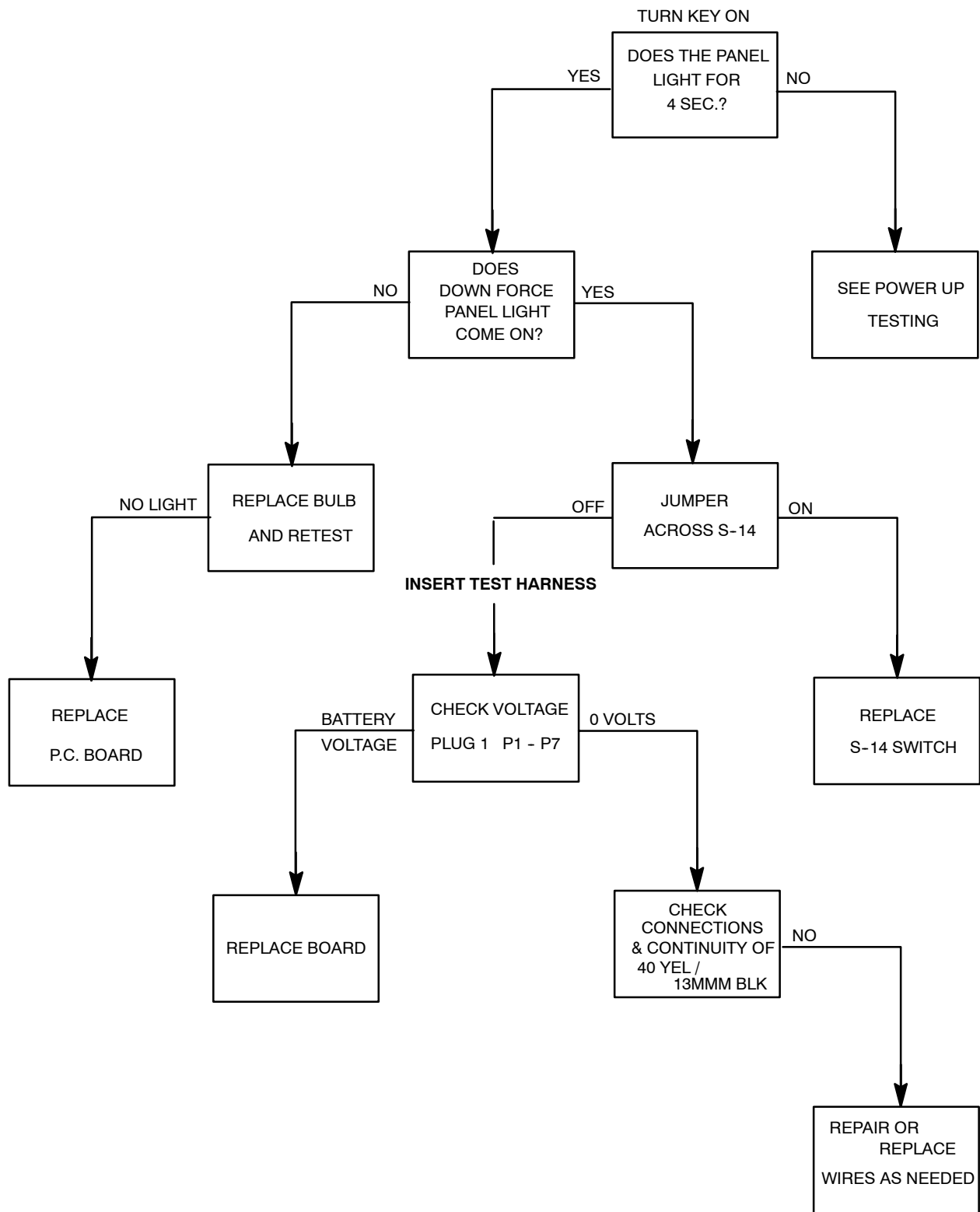

FUEL INDICATOR (GAS AND DIESEL MACHINES)

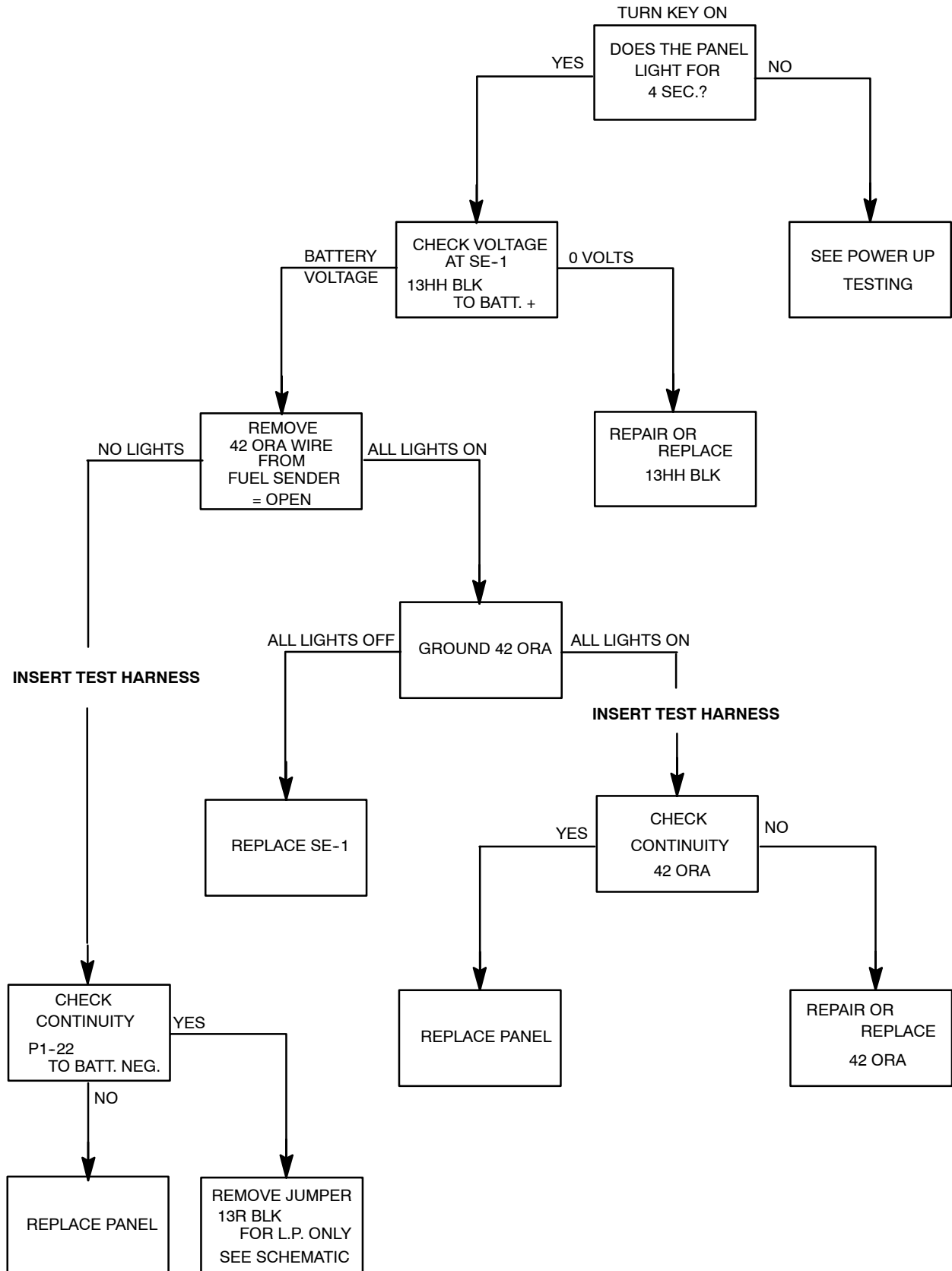

COOLANT SENDER CIRCUIT

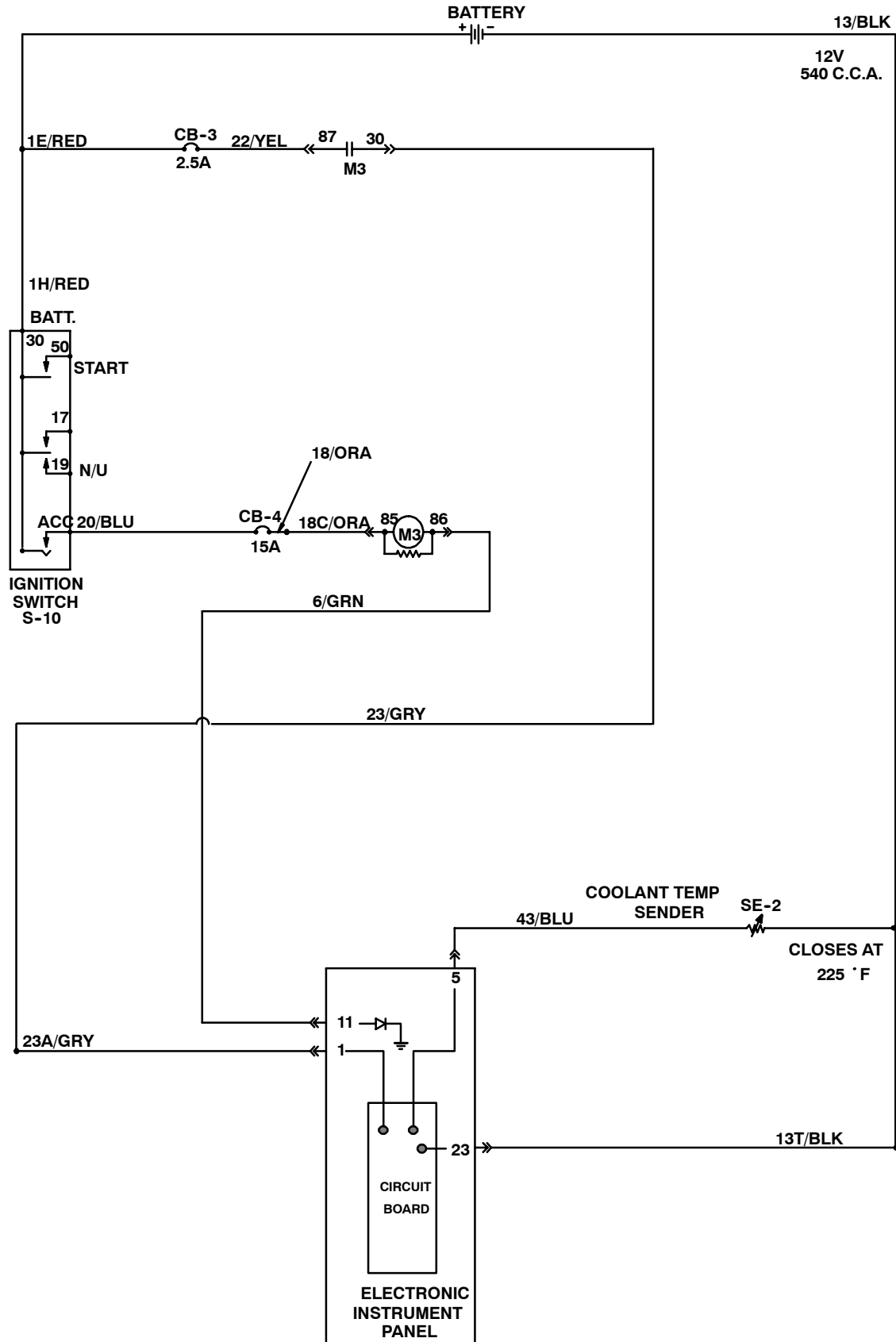

COOLANT TEMPERATURE

LIGHT WILL NOT COME ON

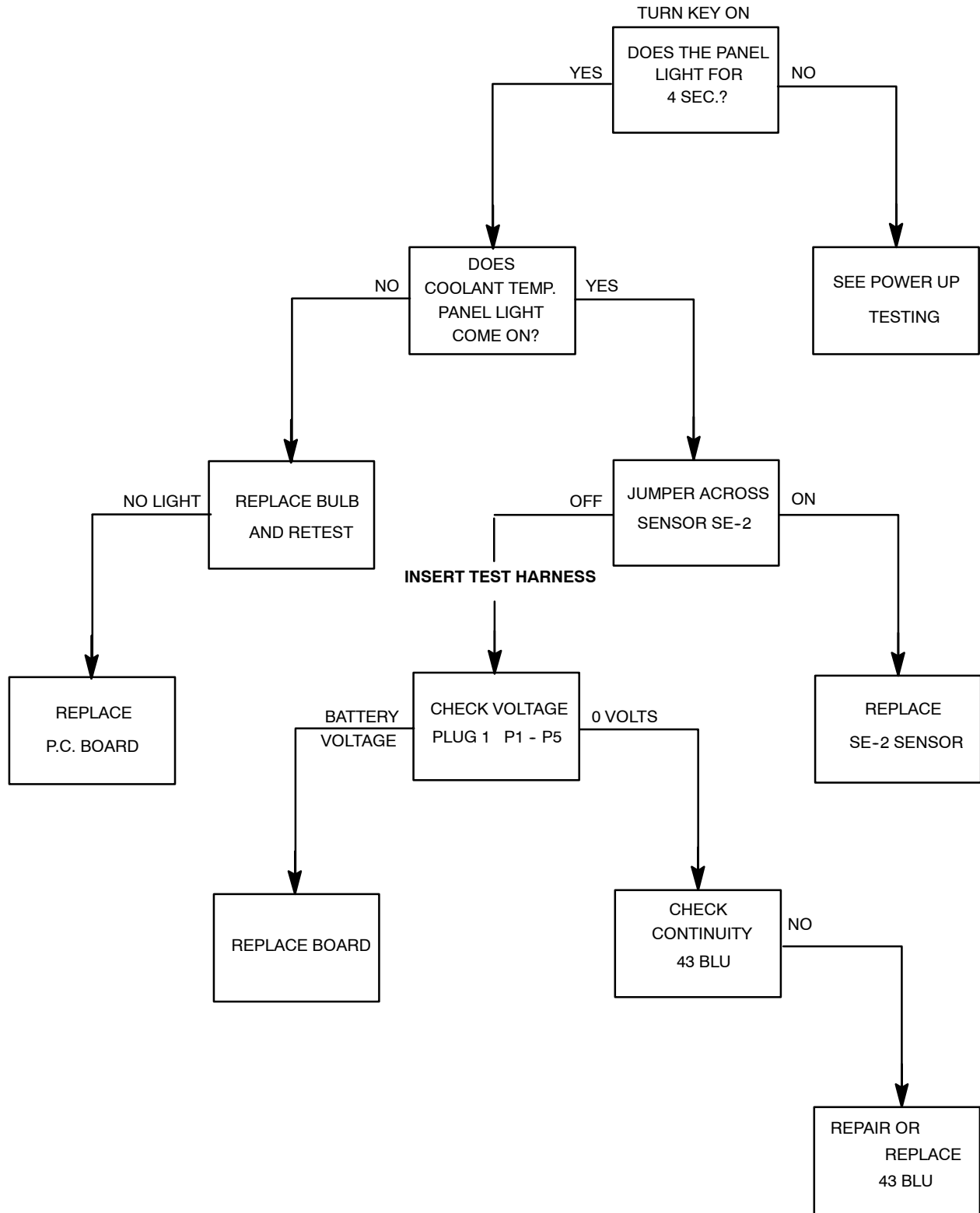

ELECTRICAL

LOW L.P. CIRCUIT (L.P. MACHINES ONLY)

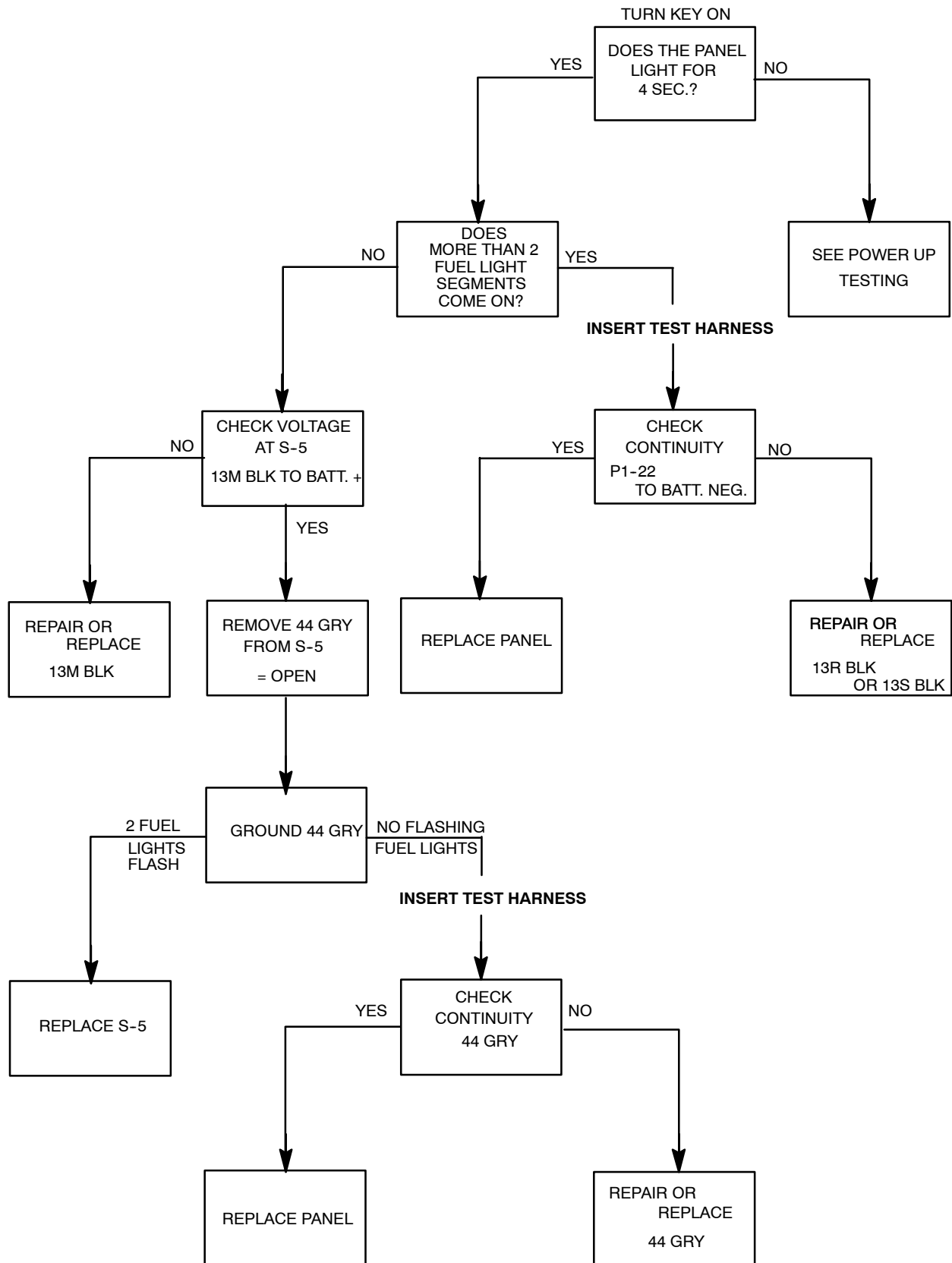

ALTERNATOR FAULT

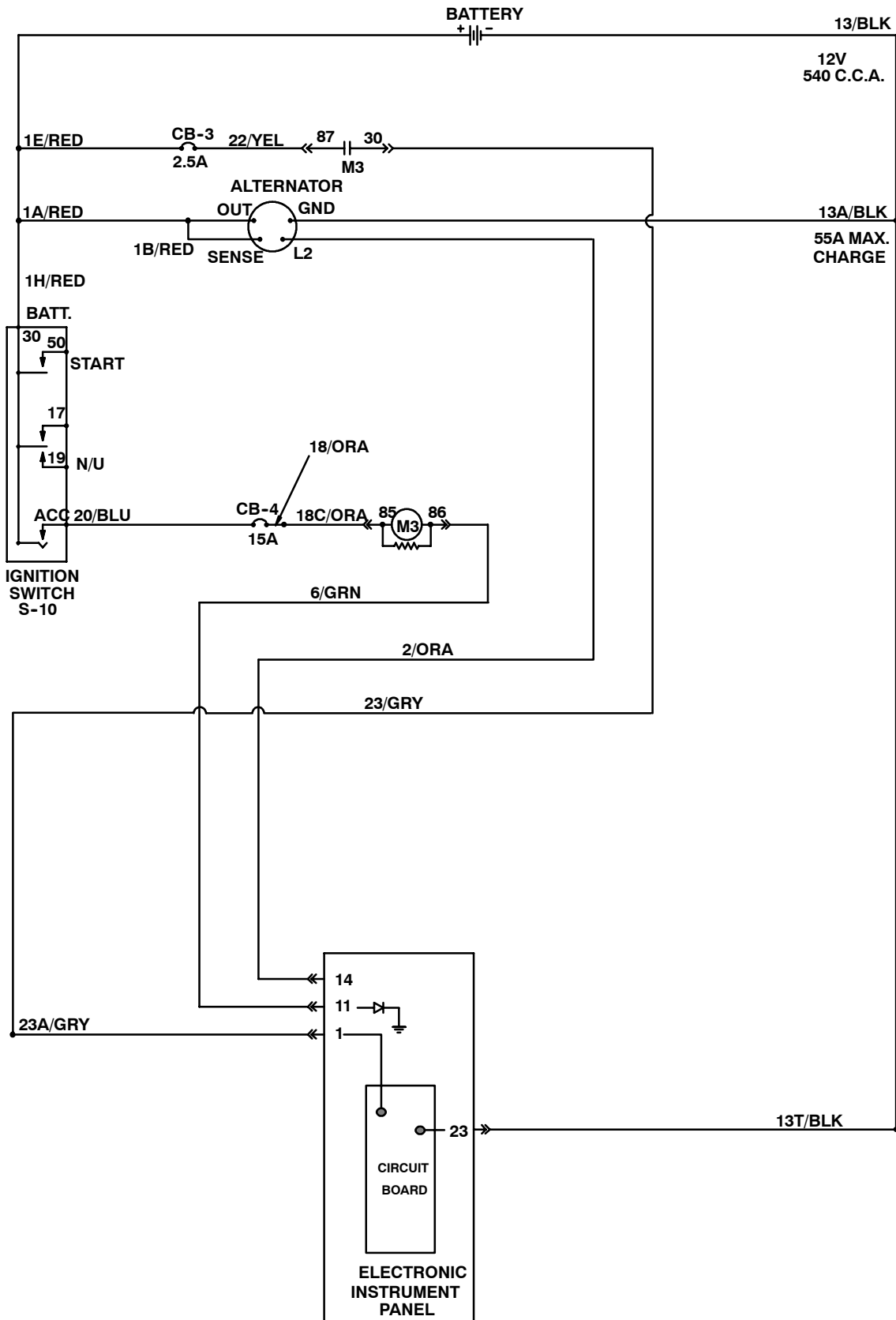

ALTERNATOR

(AFTER CHECKING THE BATTERY AND ITS CONNECTIONS)

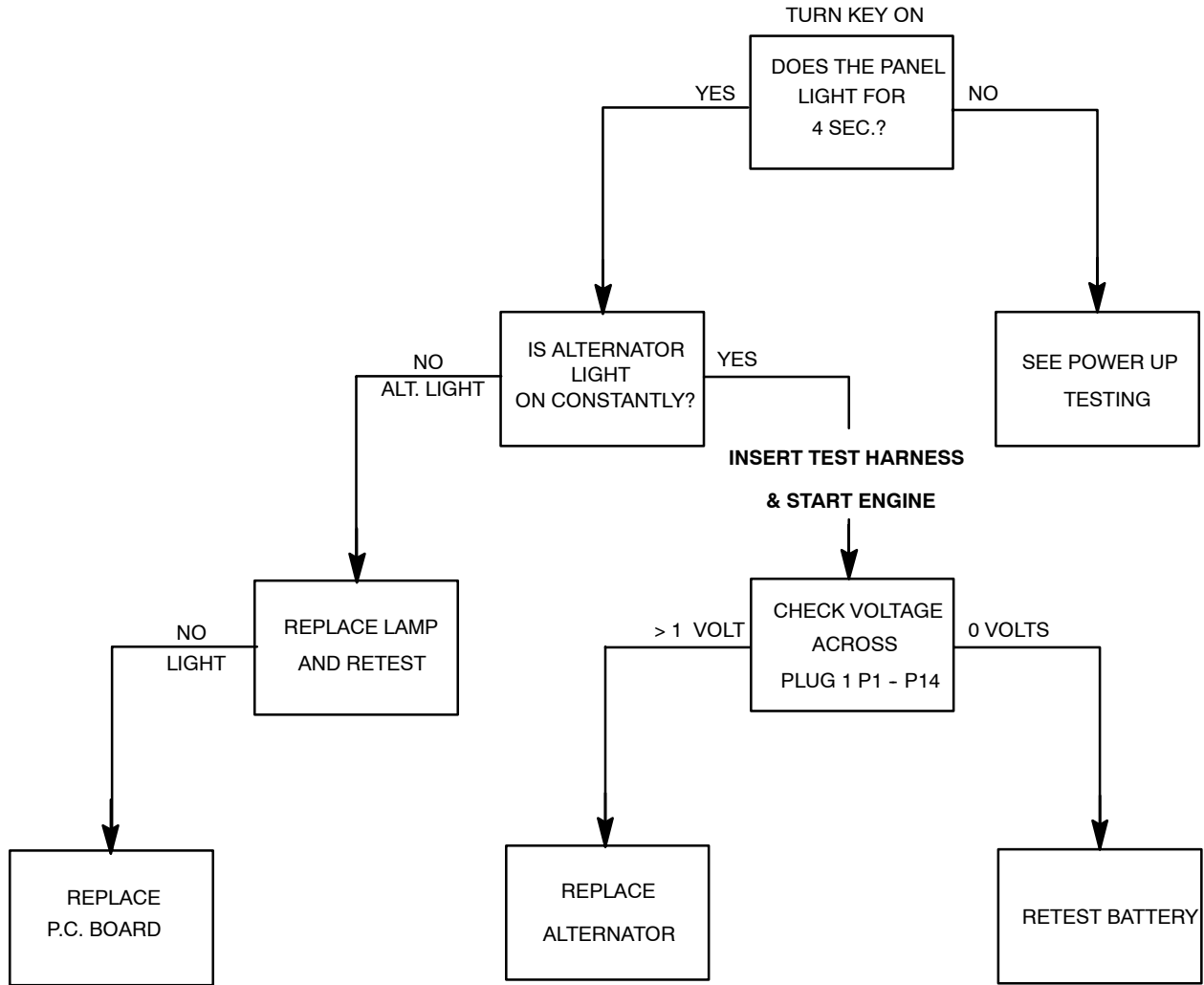

HOURMETER CIRCUIT

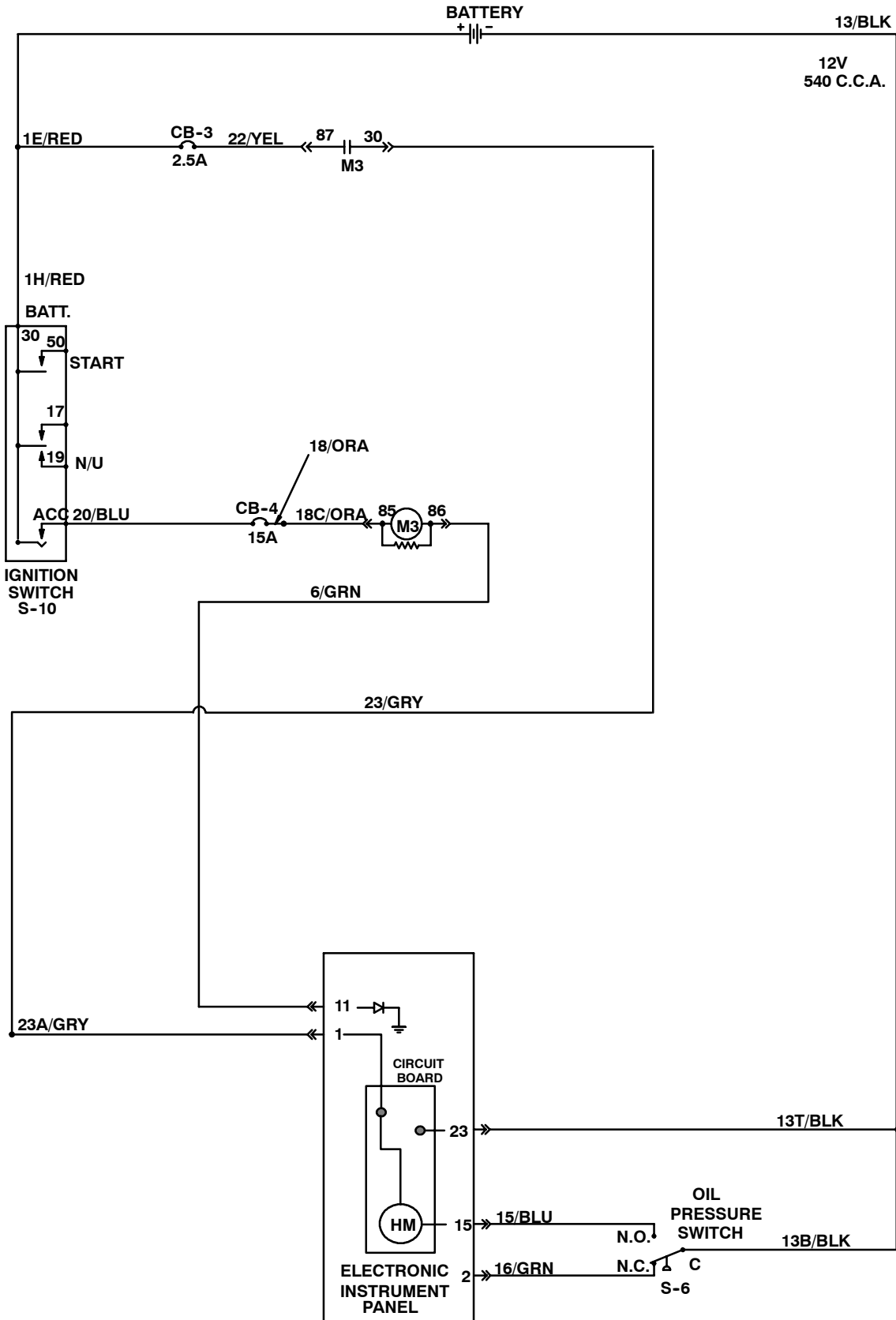

HOURMETER WON'T WORK

(THE HOURMETER RUNS WHEN THE ENGINE IS RUNNING ONLY,
NOTE: THIS TEST DOES NOT REQUIRE THE ENGINE TO RUN.)

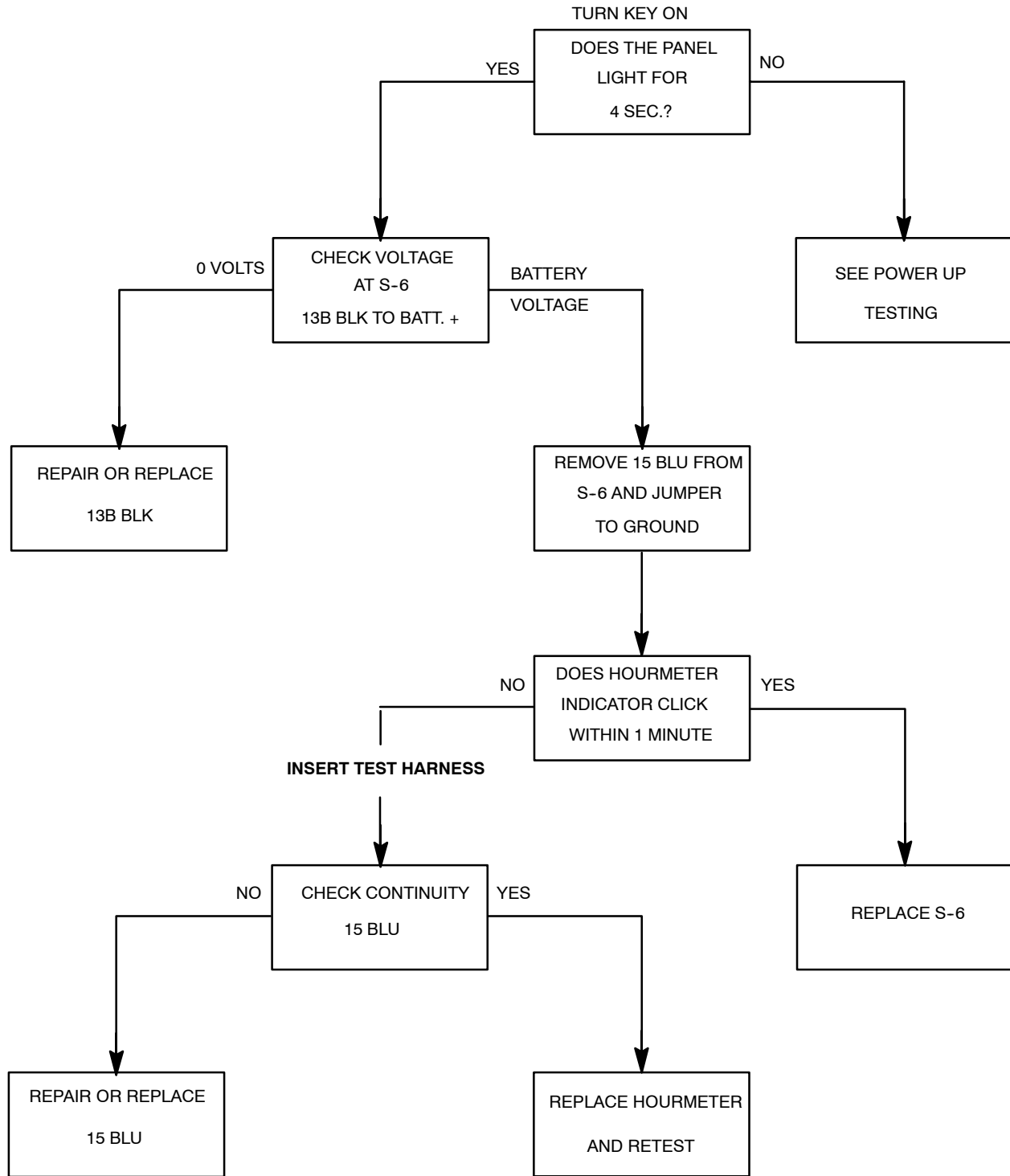

POWER UP CIRCUIT

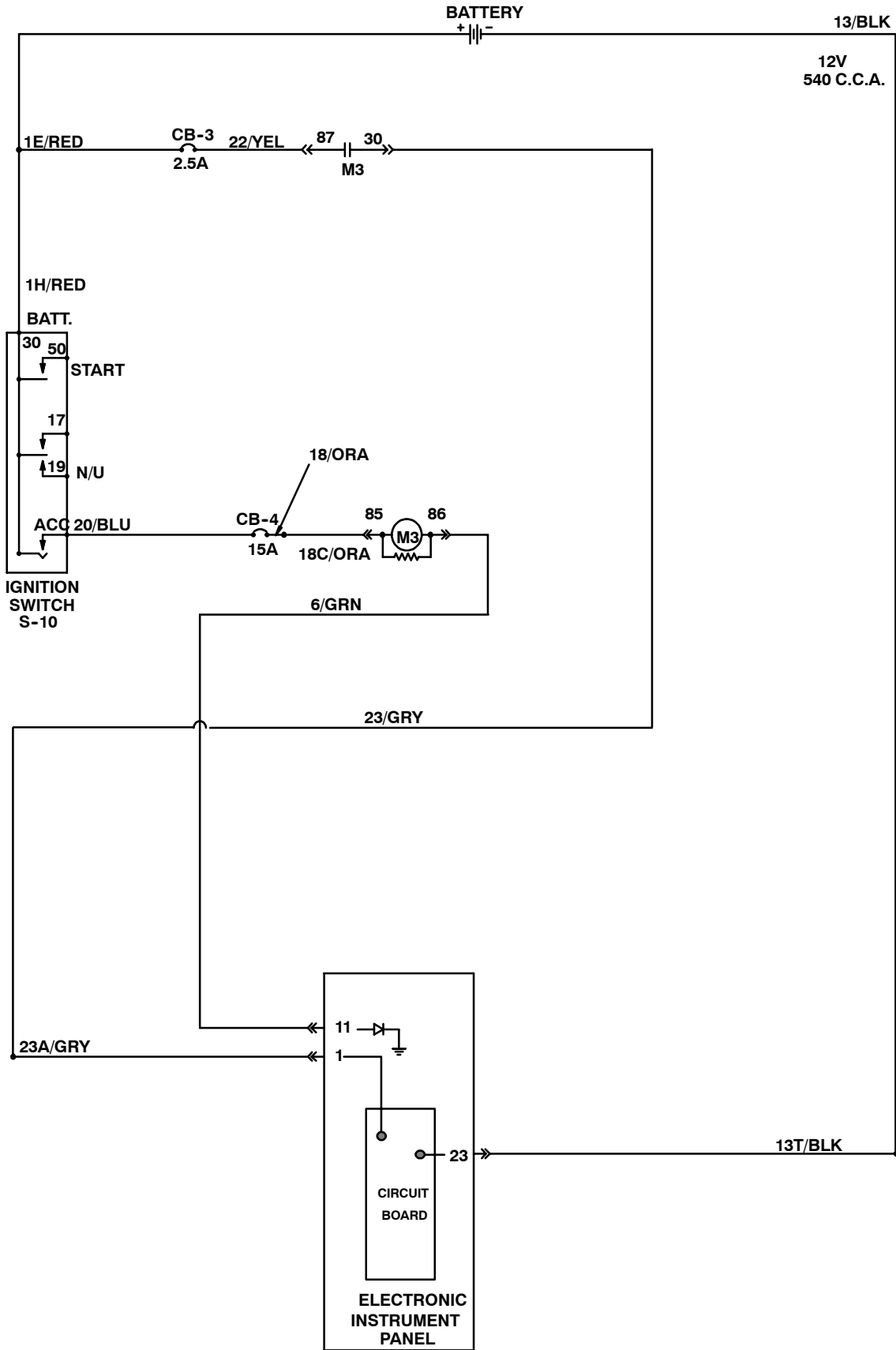

POWER UP TESTING

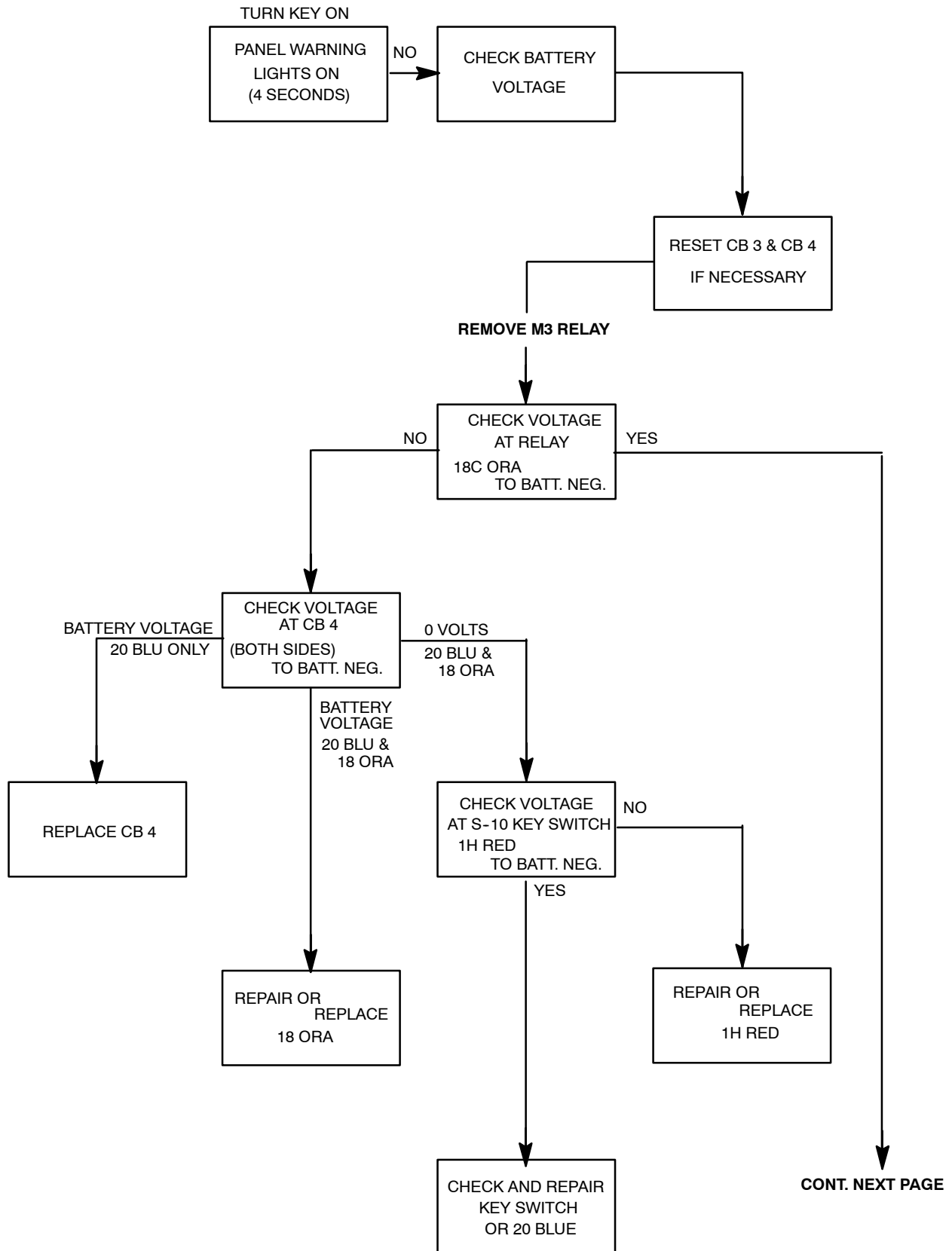

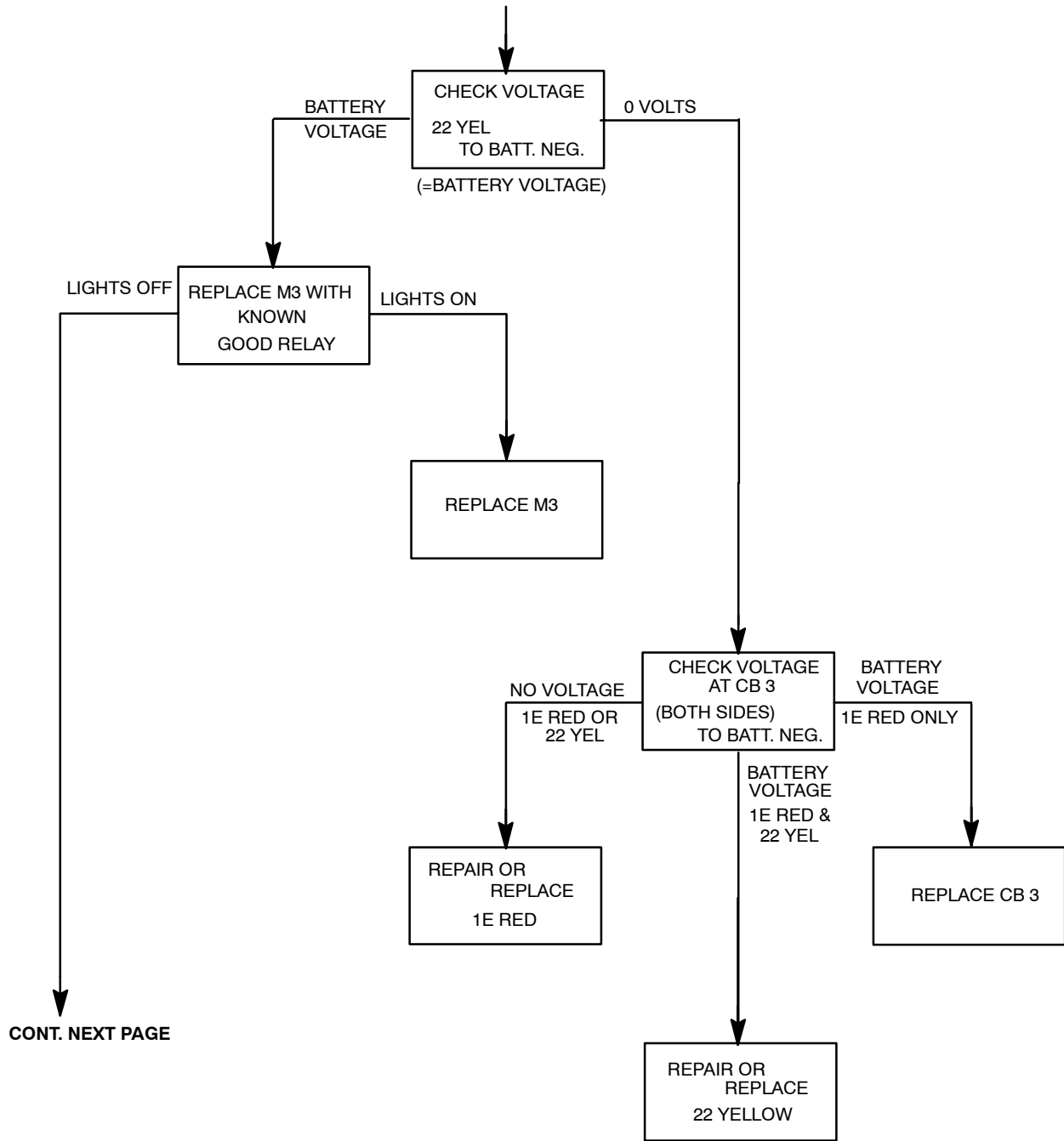

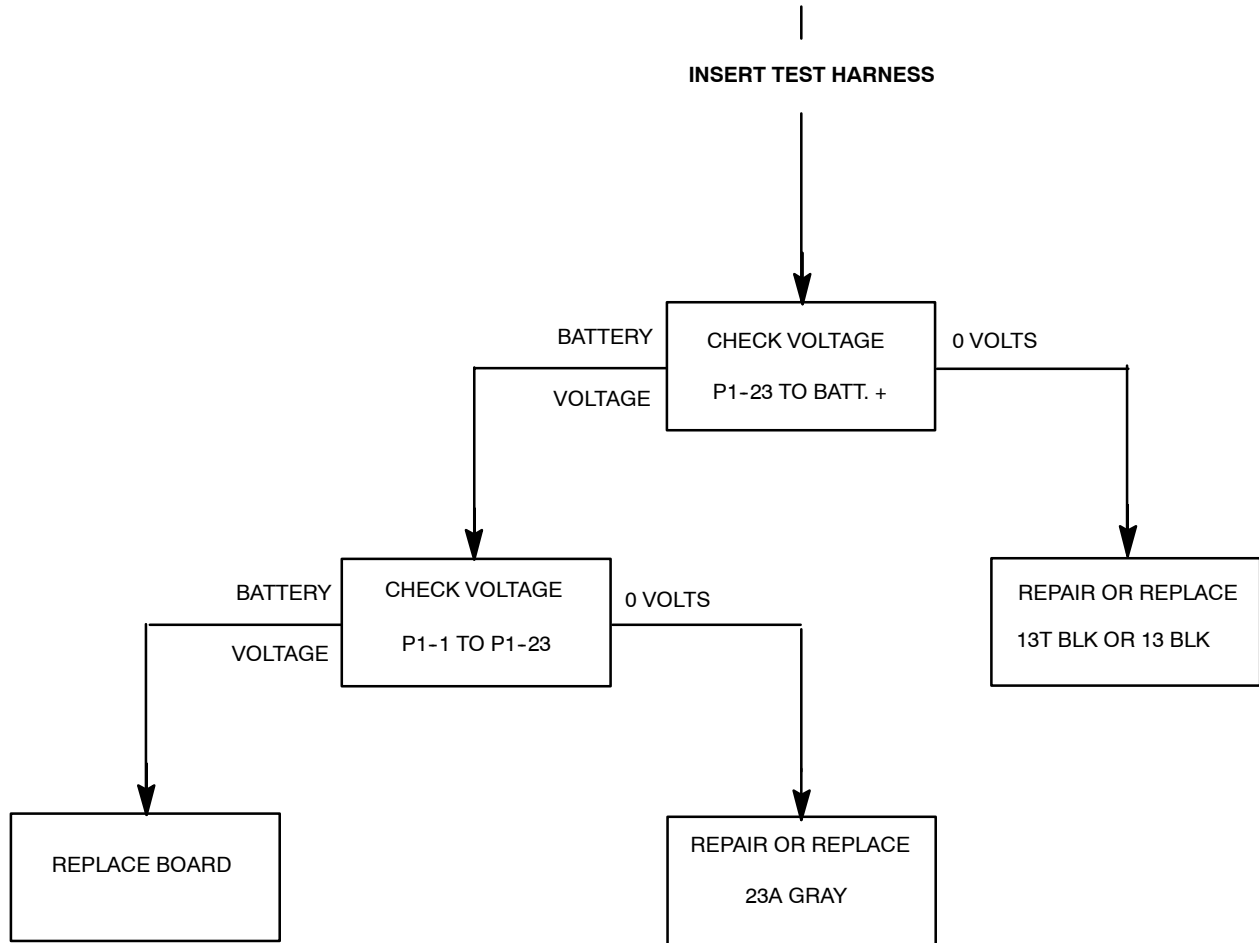

800/810 RELAY AND CIRCUIT BREAKER LOCATION

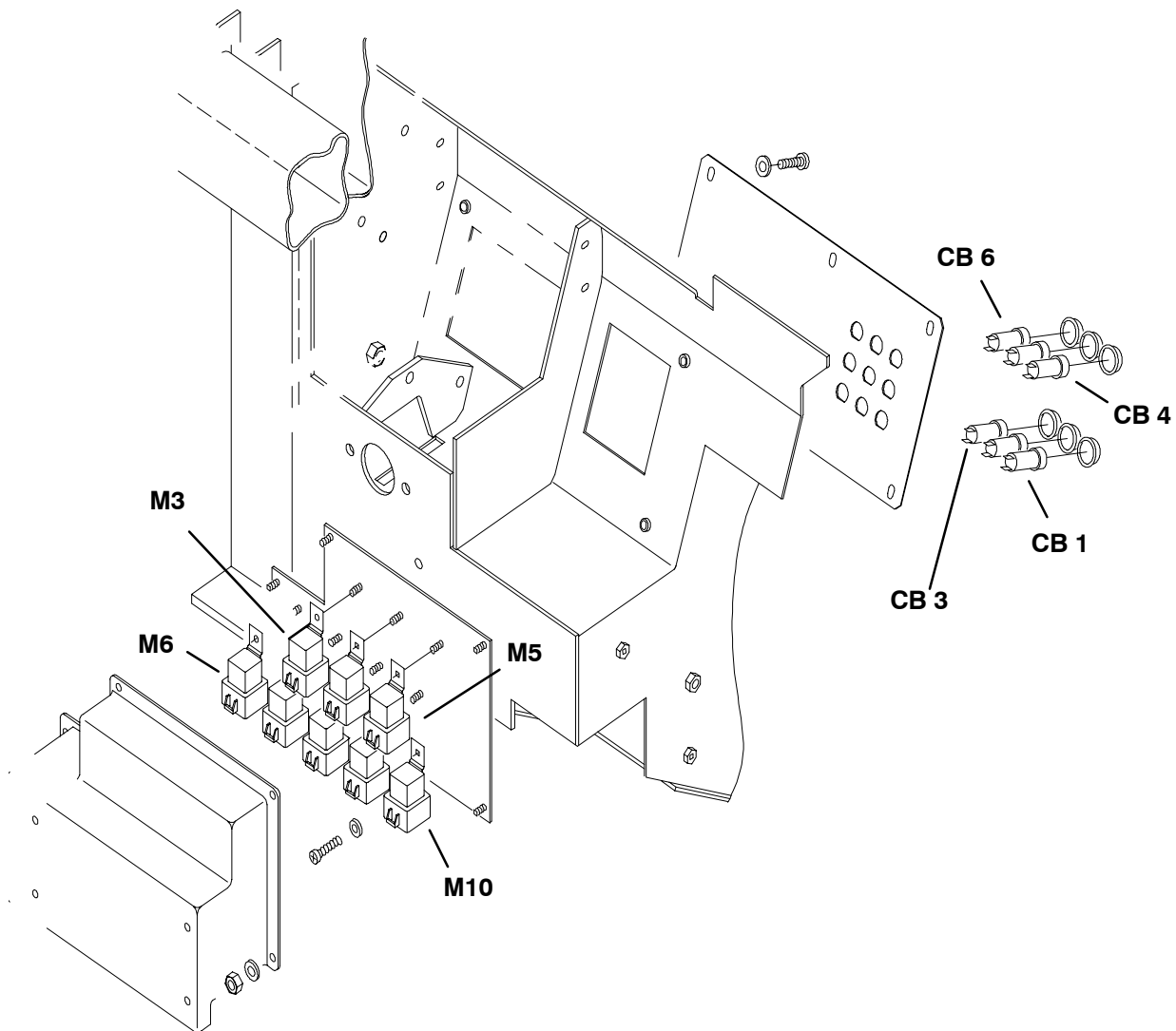

- M3 - INSTR. PANEL**
- M4 - SHAKER MOTOR**
- M5 - VAC FAN SOL.**
- M6 - HEADLIGHTS**
- M7 - FLASHING LIGHT**
- M8 - HOPPER LIFT**
- M9 - FRONT BRUSH**
- M10 - MAIN BRUSH**

- CB 1 - HORN**
- CB 2 - SHAKER MOTOR**
- CB 3 - VAC FAN RELAY**
- CB 4 - INSTR. PANEL**
- CB 5 - FLASHING LIGHT**
- CB 6 - HOPPER LIFT & BRUSHES**
- CB 7 - AUX. SIDE BRUSH**
- CB 8 - CAB ACCY.**

CONTENTS

	Page		Page
HYDRAULIC FLUID RESERVOIR	5-3	VACUUM FAN	5-47
TO DRAIN HYDRAULIC FLUID		TO REPLACE VACUUM FAN	
RESERVOIR AND REPLACE		HYDRAULIC MOTOR	5-47
FILTER ELEMENT	5-4	Fig. 1 - Hydraulic Schematic	
TO FILL HYDRAULIC FLUID		800 G/LPG/D (for machines below	
RESERVOIR	5-4	serial number 2300)	5-50
HYDRAULIC FLUID	5-5	Fig. 2 - Hydraulic Schematic	
HYDRAULIC HOSES	5-5	800 G/LPG/D (for machines serial	
DIRECTIONAL CONTROL	5-6	number 2300 and above)	5-52
DIRECTIONAL PEDAL	5-6	Fig. 3 - Hydraulic Schematic	
TO REPLACE DIRECTIONAL PEDAL		810 G/LPG/D (for machines below	
CENTERING SPRING	5-6	serial number 2300)	5-54
TO REPLACE DIRECTIONAL		Fig. 4 - Hydraulic Schematic	
CONTROL CABLE	5-8	810 G/LPG/D (for machines serial	
TO ADJUST DIRECTIONAL		number 2300 and above)	5-56
CONTROL	5-11	Fig. 5 - Hydraulic Hose Group	
HYDRAULIC COMPONENTS	5-12	800 G/LPG/D (for machines below	
TO REPLACE PROPEL PUMP	5-12	serial number 2300)	5-58
TO REPLACE ACCESSORY PUMP .	5-14	Fig. 6 - Hydraulic Hose Group	
TO REPLACE HOPPER LIFT		810 G/LPG/D (for machines below	
CYLINDER	5-16	serial number 2300)	5-59
TO REPLACE STEERING		TROUBLESHOOTING	5-61
CYLINDER	5-18	800 MAIN - LO SPD AND VAC FAN .	5-62
TO REPLACE HOPPER ROLL OUT		810 REAR BROOM AND VAC FAN ..	5-63
CYLINDERS	5-20	800 MAIN, S. BR. AND VAC FAN ...	5-64
TO REPLACE HOPPER DUMP		810 ALL BROOMS AND VAC FAN ...	5-65
DOOR CYLINDERS	5-22	800 / 810 HOPPER LOWER	5-66
TO REPLACE MAIN BRUSH LIFT		800 / 810 HOPPER LIFT	5-67
CYLINDER	5-24	800 / 810 DOOR OPEN	5-68
TO REPLACE SIDE BRUSH LIFT		800 / 810 DOOR CLOSE	5-69
CYLINDER	5-26	800 / 810 ROLL IN	5-70
TO REPLACE POWER THROW™		800 / 810 ROLL OUT	5-71
BRUSH LIFT CYLINDER	5-28	800 / 810 RIGHT TURN	5-72
TO REPLACE SIDE BRUSH		800 / 810 LEFT TURN	5-73
SOLENOID VALVE	5-30	800/810 COOLANT FAN	5-74
TO REPLACE HYDRAULIC LIFT		EATON REPAIR INFORMATION	5-75
VALVE	5-31		
TO REPLACE HYDRAULIC			
STEERING VALVE	5-33		
TO REPLACE HYDRAULIC			
SOLENOID VALVE	5-35		
TO REPLACE SOLENOID VALVE			
CARTRIDGE	5-37		
TO REPLACE ENGINE COOLING			
FAN HYDRAULIC MOTOR	5-38		
TO REPLACE REAR DRIVE			
MOTOR	5-40		
TO REPLACE MAIN BRUSH			
MOTOR	5-42		
TO REPLACE SIDE BRUSH			
MOTOR	5-44		
TO REPLACE POWER THROW™			
BRUSH MOTOR	5-45		

HYDRAULIC FLUID RESERVOIR

The reservoir is located behind the operator seat.

Mounted on top of the reservoir is a filler cap with a built-in breather. Replace the cap every 800 hours of operation.

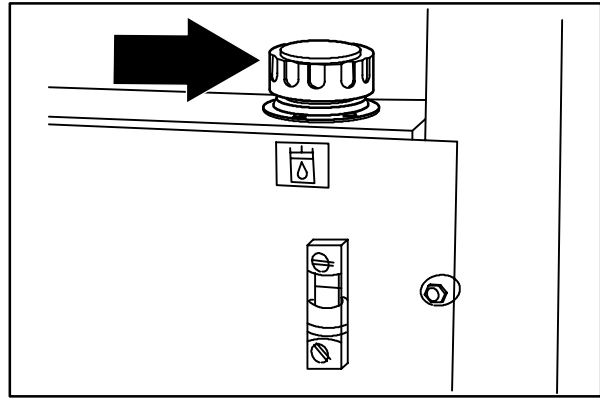

08452

Check the hydraulic fluid level at operating temperature every 100 hours of operation. Make sure the hopper is down when checking hydraulic fluid level. The sight gauge is marked with full, the black line, and add, the red line, levels to indicate the level of hydraulic fluid in the reservoir.

Lubricate the filler cap gasket with a film of hydraulic fluid before putting the cap back on the reservoir.

ATTENTION! Do not overfill the hydraulic fluid reservoir or operate the machine with a low level of hydraulic fluid in the reservoir. Damage to the machine hydraulic system may result.

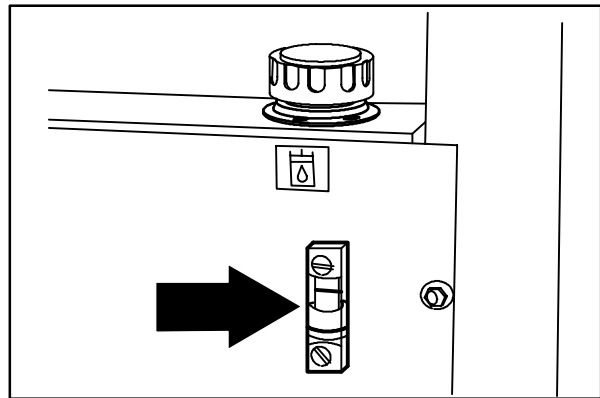

08430

Drain and refill the hydraulic fluid reservoir with new hydraulic fluid every 800 hours of operation.

The hydraulic fluid filter is located in the engine compartment.

Replace the filter element every 800 hours of operation.

The reservoir has a built-in strainer outlet that filters hydraulic fluid before it enters the system. Replace the strainer every 800 hours of operation.

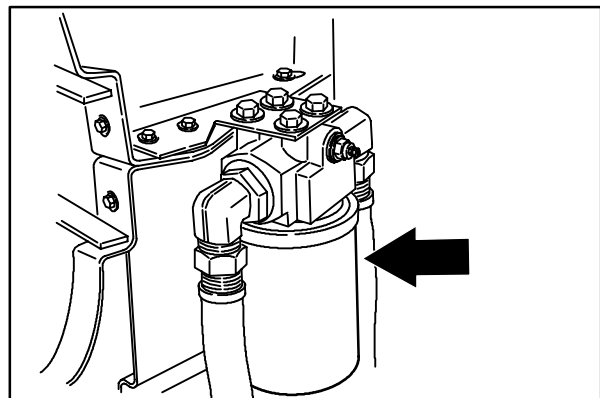

08453

HYDRAULICS

TO DRAIN HYDRAULIC FLUID RESERVOIR AND REPLACE FILTER ELEMENT

1. Stop the engine and set the parking brake.

FOR SAFETY: Before Leaving Or Servicing Machine; Stop On Level Surface, Set Parking Brake, Turn Off Machine And Remove Key.

2. Wait for the hydraulic fluid to cool down.
3. Un-thread and discard the hydraulic fluid filter element. Hydraulic fluid will drain through the filter head. Discard the used hydraulic fluid. Loosen the breather-filter cap.

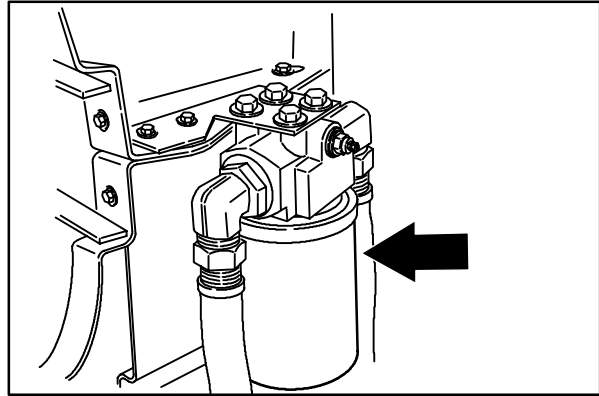

08453

NOTE: Be aware the hydraulic filter is lower than the reservoir. All fluid will drain from the reservoir. Discard all hydraulic fluid drained from the system. The fluid may contain foreign material harmful to the hydraulic system.

4. Apply a thin coat of hydraulic fluid to the seal of the new hydraulic fluid filter element.
5. Thread and hand tighten the new hydraulic fluid filter element on the filter head.

TO FILL HYDRAULIC FLUID RESERVOIR

1. Remove the reservoir breather-filler cap.
2. Pour new, approved hydraulic fluid through a 200 mesh screened funnel into the reservoir.

ATTENTION! Use only new, approved hydraulic fluid to fill the hydraulic fluid reservoir. Do not overfill!

3. Check the hydraulic fluid level in the reservoir with the sight gauge.
4. Add hydraulic fluid until the level in the reservoir is in between the full, black line and the add, red line. Do not overfill!

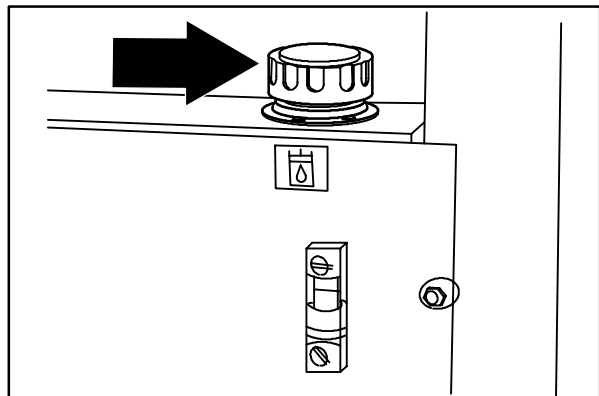

08452

NOTE: Do not overfill the hydraulic fluid reservoir. Hydraulic fluid expands as it reaches its normal operating temperature. Always allow for expansion when filling the reservoir.

5. Put the reservoir breather-filler cap on the reservoir.
6. Start engine and operate all the hydraulic components.
7. Recheck the hydraulic fluid level.
8. Check for any leaks.

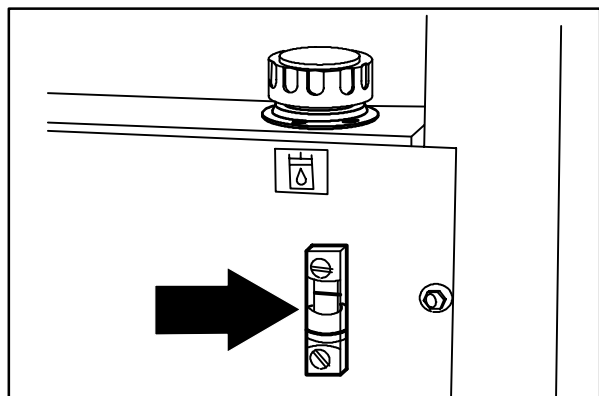

08430

HYDRAULIC FLUID

The quality and condition of the hydraulic fluid play a very important role in how well the machine operates. TENNANT's hydraulic fluid is specially selected to meet the needs of TENNANT machines.

TENNANT's hydraulic fluids provide a longer life for the hydraulic components. There are two fluids available for different temperature ranges:

TENNANT part no.	Ambient Temperature
65870-1	above 0° C (32° F)
74217-1	below 0° C (32° F)

The higher temperature fluid has a higher viscosity and should not be used at the lower temperatures. Damage to the hydraulic pumps may occur because of improper lubrication.

The lower temperature fluid is a thinner fluid for colder temperatures.

If a locally-available hydraulic fluid is used, make sure the specifications match TENNANT hydraulic fluid specifications. Using substitute fluids can cause premature failure of hydraulic components.

ATTENTION! Hydraulic components depend on system hydraulic fluid for internal lubrication. Malfunctions, accelerated wear, and damage will result if dirt or other contaminants enter the hydraulic system.

HYDRAULIC HOSES

Check the hydraulic hoses every 200 hours of operation for wear or damage.

Fluid escaping at high pressure from a very small hole can be almost invisible, and can cause serious injuries.

See a doctor at once if injury results from escaping hydraulic fluid. Serious infection or reaction can develop if proper medical treatment is not given immediately.

FOR SAFETY: When Servicing Machine, Use Cardboard To Locate Leaking Hydraulic Fluid Under Pressure.

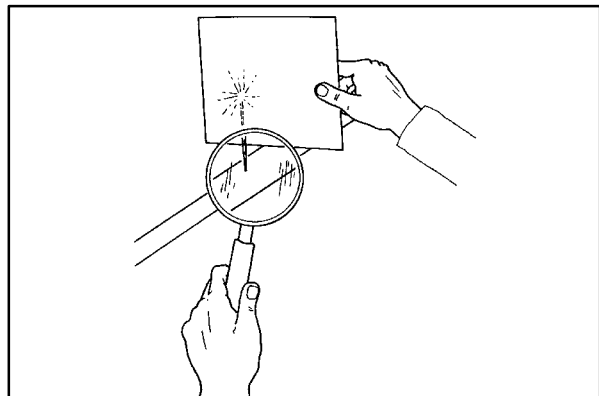

00002

DIRECTIONAL CONTROL

DIRECTIONAL PEDAL

The directional pedal controls the flow of hydraulic fluid to the hydraulic propelling motor. The pedal neutral position is the position in which the propelling pump sends no hydraulic fluid to the propelling motor. The machine should not move when the pedal neutral position is adjusted correctly. The pedal linkages should also be adjusted whenever the reverse is faster or slower than machine specification.

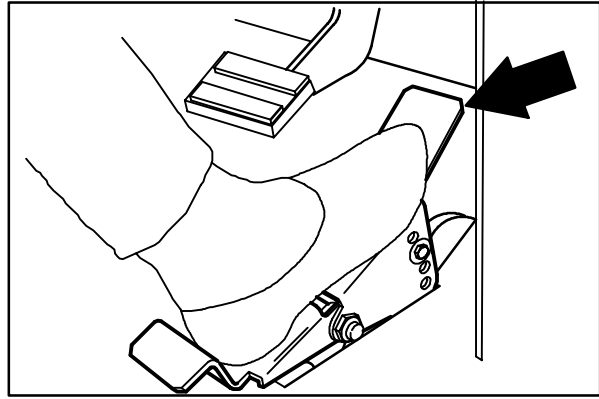

08467

TO REPLACE DIRECTIONAL PEDAL CENTERING SPRING

FOR SAFETY: Before Leaving Or Servicing Machine; Stop On Level Surface, Set Parking Brake, Turn Off Machine And Remove Key.

1. Raise the hopper and engage the prop arm.



WARNING: Raised Hopper May Fall. Engage Hopper Support Bar.

2. Remove the clevis pin holding the hopper up speed cable to the right side lift arm.
3. Remove the rubber floor mat from machine operator compartment.
4. Remove the seven M8 hex screws from the directional pedal plate.
5. Lift the plate up and back so the directional spring assembly is accessible.
6. Remove the M6 hex screw from the bracket attaching the ball joint to the directional pedal assembly.
7. Unscrew the spacer from threaded end of the directional spring assembly and save.
8. Loosen the large jam nuts holding directional spring assembly to the pedal plate. Drop the directional spring assembly down, off the pedal plate.

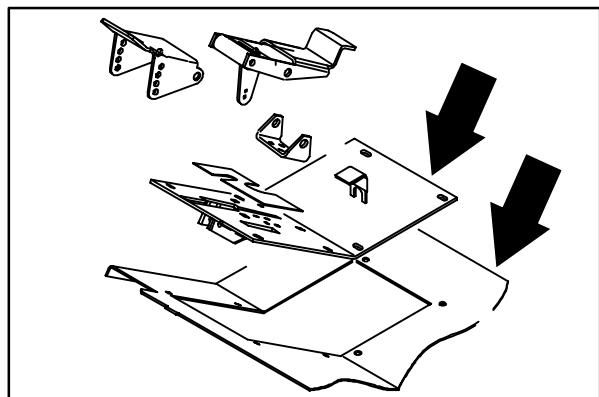
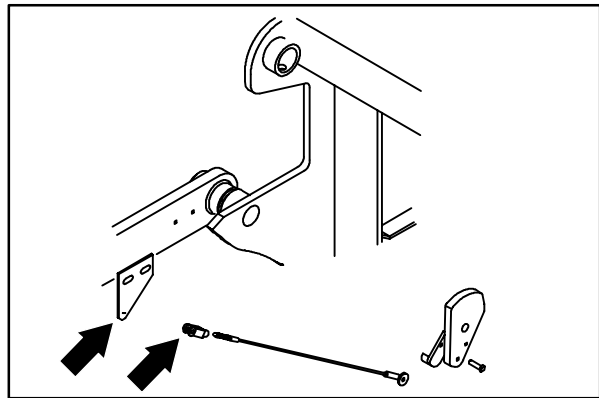
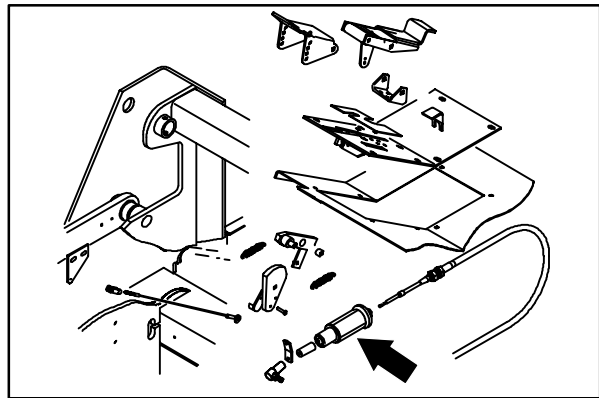

9. Unscrew the directional spring assembly from the directional control cable using the flats located at the end of spring assembly.

NOTE: The cable may have to be held to keep it from turning.

10. Thread a new directional spring assembly back on the directional control cable.
11. Use the large jam nut to lock the directional spring assembly in place.
12. Thread the spacer back on the end of the cable.
13. Reconnect the spacer to the ball joint bracket using the M6 hex screw. Tighten to 8 - 10 Nm (5 - 7 ft lb).
14. Position the directional cable assembly back on the pedal plate. Hand tighten the large jam nuts.
15. Place the pedal plate back down on floor of the operators compartment. Reinstall the seven M8 hex screws and tighten to 19 - 24 Nm (15 - 20 ft lb).
16. Reinstall the rubber floor mat.
17. Reconnect the hopper up speed cable to the right hand lift arm.
18. Disengage the hopper prop arm and lower the hopper. Lift the rear drive tire off the ground and place jack stands under the frame.

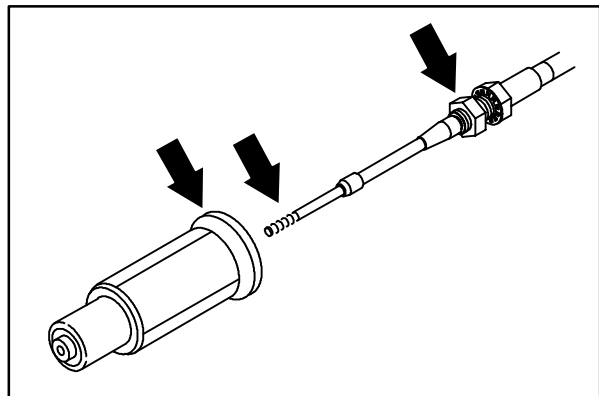
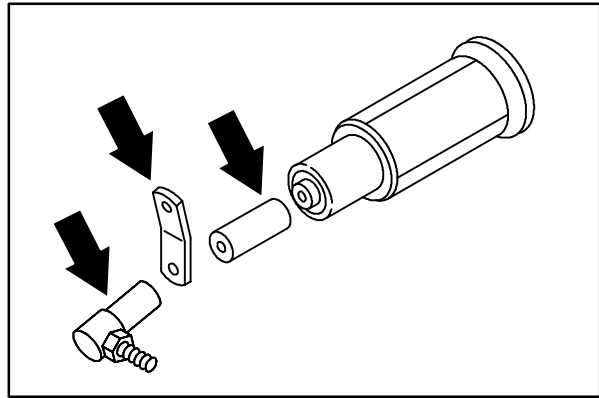

FOR SAFETY: Block machine tires before jacking machine up. Jack machine up at designated locations only. Block machine up with jack stands.

19. Check the adjustment of the new directional spring assembly by starting the machine and checking the rear drive tire for any rotation. If the tire is rotating in either direction see TO ADJUST DIRECTIONAL CONTROL instructions in this section.

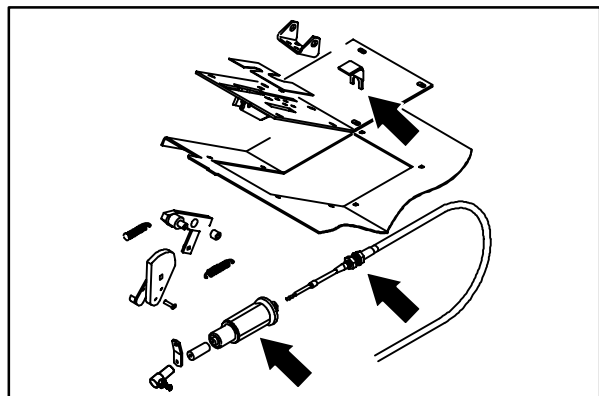

HYDRAULICS

TO REPLACE DIRECTIONAL CONTROL CABLE

FOR SAFETY: Before Leaving Or Servicing Machine; Stop On Level Surface, Set Parking Brake, Turn Off Machine And Remove Key.

1. Raise the hopper and engage the prop arm.

⚠ WARNING: Raised Hopper May Fall. Engage Hopper Support Bar.

2. Remove the clevis pin holding the hopper up speed cable to the right side lift arm.
3. Remove the rubber floor mat from machine operator compartment.
4. Remove the seven M8 hex screws from the directional pedal plate.
5. Lift the plate up and back so the directional spring assembly is accessible.
6. Remove the M6 hex screw from the bracket attaching the ball joint to the directional pedal assembly.
7. Unscrew the spacer from threaded end of the directional spring assembly and save.
8. Loosen the large jam nuts holding directional spring assembly to the pedal plate. Drop the directional spring assembly down, off the pedal plate.
9. Unscrew the directional spring assembly from the directional control cable using the flats located at the end of spring assembly.

NOTE: The cable may have to be held to keep it from turning.

10. Open the engine cover and side door. Locate the propel pump under the radiator/fan shroud assembly.

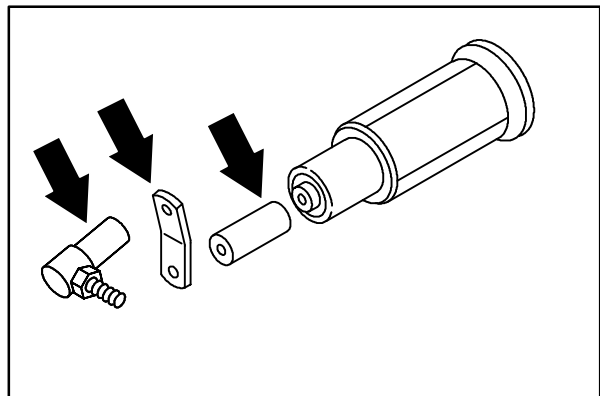
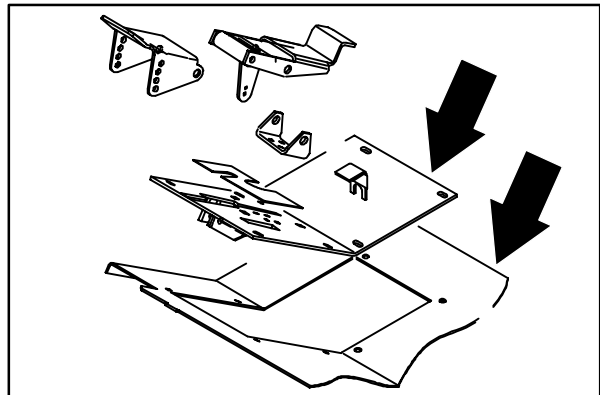
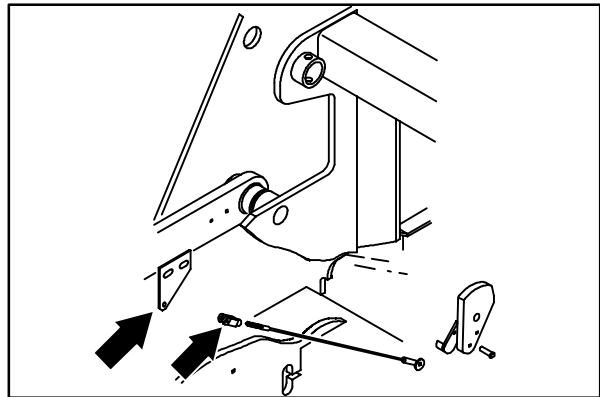
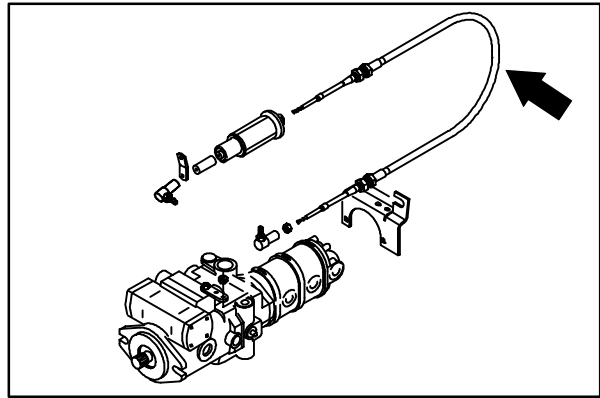

11. Remove the nyloc nut holding the ball joint/directional cable to the propel pump directional arm. Remove the ball joint and jam nut from the cable.
12. Loosen the two large jam nuts on the control cable. Remove the cable from the bracket.
13. Remove any clamps or ties holding the control cable to the machine frame. Carefully remove the cable from the machine.
14. Reinstall jam nut and ball joint on the new directional control cable.
15. Install the new control cable in the machine. Use the same route as the old cable.
16. Reinstall any clamps or ties used to secure the old cable.
17. Reinstall the M6 nyloc nut on the ball joint.
18. Place the cable assembly in the slot on the mount bracket. Hand tighten the large jam nuts.

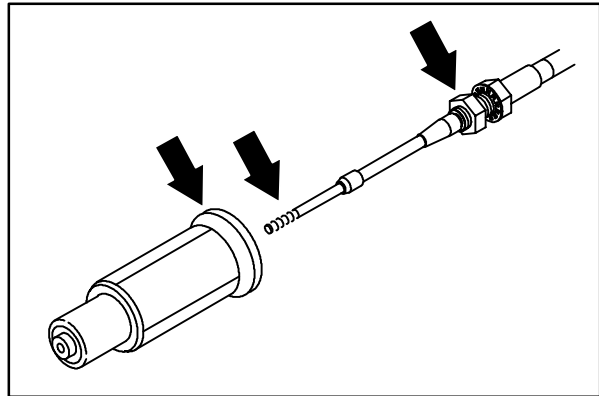

NOTE: Try to position the new control cable as close as possible to the position of the old cable.

19. Thread the old directional spring assembly on the new directional control cable at the other end of the cable in the operators compartment.
20. Use the large jam nut to lock the directional spring assembly in place.
21. Thread the spacer back on the end of the cable.

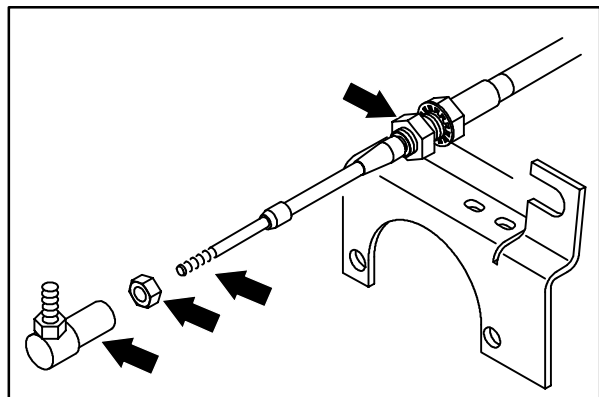
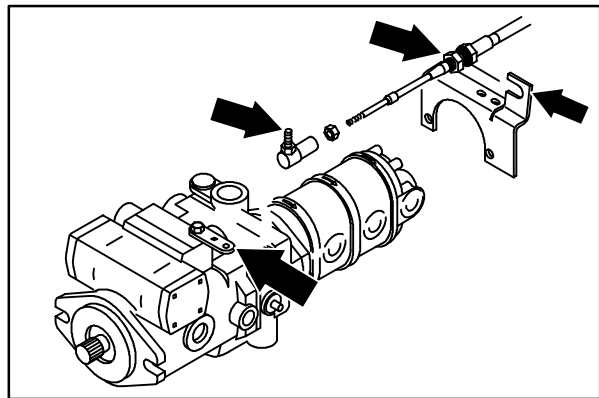

HYDRAULICS

22. Reconnect the spacer to the ball joint bracket using the M6 hex screw. Tighten to 8 - 10 Nm (5 - 7 ft lb).
23. Position the directional cable assembly back on the pedal plate. Hand tighten the large jam nuts.
24. Place the pedal plate back down on floor of the operators compartment. Reinstall the seven M8 hex screws and tighten to 19 - 24 Nm (15 - 20 ft lb).
25. Reinstall the rubber floor mat.
26. Reconnect the hopper up speed cable to the right hand lift arm.
27. Close the engine cover and side door.
28. Disengage the hopper prop arm and lower the hopper. Lift the rear drive tire off the ground and place jack stands under the frame.

FOR SAFETY: Block machine tires before jacking machine up. Jack machine up at designated locations only. Block machine up with jack stands.

29. Check the adjustment of the new directional spring assembly by starting the machine and checking the rear drive tire for any rotation. If the tire is rotating in either direction see TO ADJUST DIRECTIONAL CONTROL instructions in this section.

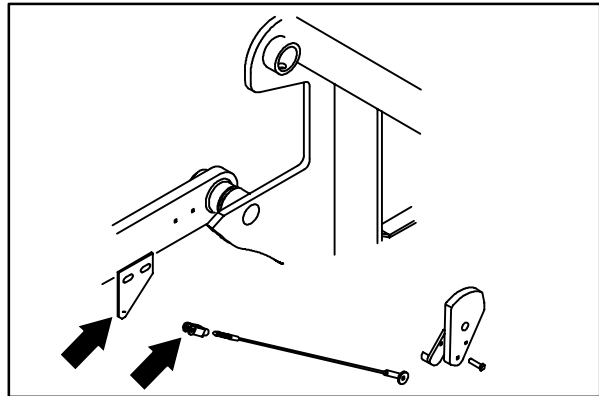
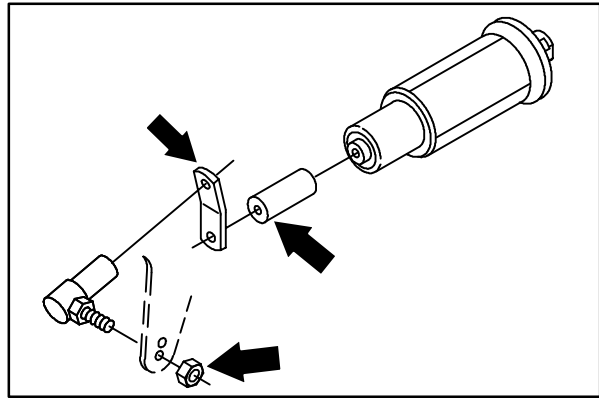

TO ADJUST DIRECTIONAL CONTROL

FOR SAFETY: Before Leaving Or Servicing Machine; Stop On Level Surface, Set Parking Brake, Turn Off Machine And Remove Key.

1. Lift the rear drive tire off the ground and place jack stands under the frame.

FOR SAFETY: Block machine tires before jacking machine up. Jack machine up at designated locations only. Block machine up with jack stands.

2. Check the neutral centering of the pump by starting the machine and observing the rear tire for any rotation. If the tire is rotating in either direction, shut off the engine.

3. Open the engine cover and side door. Locate the propel pump under the radiator/fan shroud assembly.

4. Remove the nyloc nut holding the ball joint/directional cable to the propel pump directional arm. Lift the ball joint up out of the arm.

5. Start the engine. With the ball joint disconnected from arm the pump should automatically be in neutral.

6. Shut off the engine. Loosen the jam nut locking the ball joint to control cable. Turn the ball joint until it lines up with the hole in the pumps directional arm.

7. Reinstall M6 nyloc nut to ball joint. Hand tighten.

8. Check neutral centering of pump by starting machine and observing rear tire for any rotation. If pump still is not centered, repeat steps 4 - 7.

9. The large jam nuts on the control cable can be loosened and repositioned for more adjustment.

10. Remove the jack stands and lower the machine. Operate the machine and check for proper pedal centering.

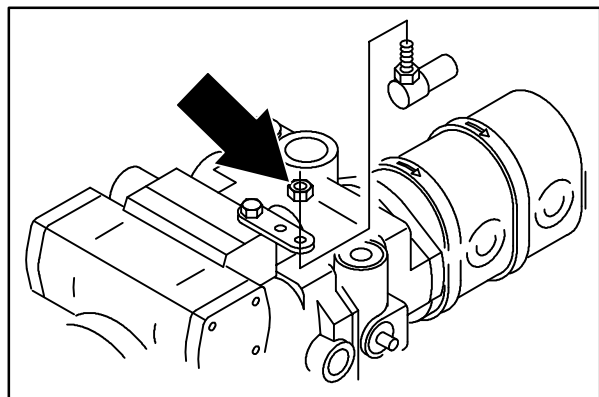
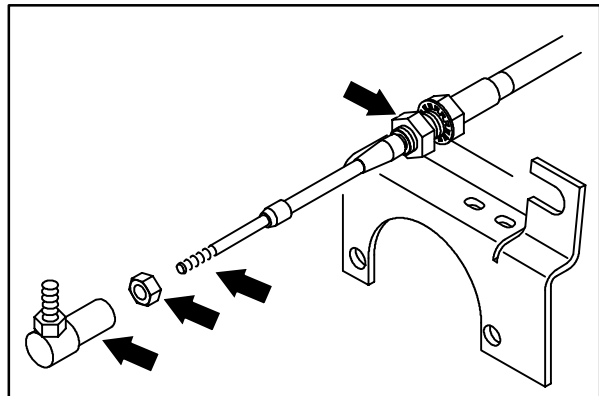
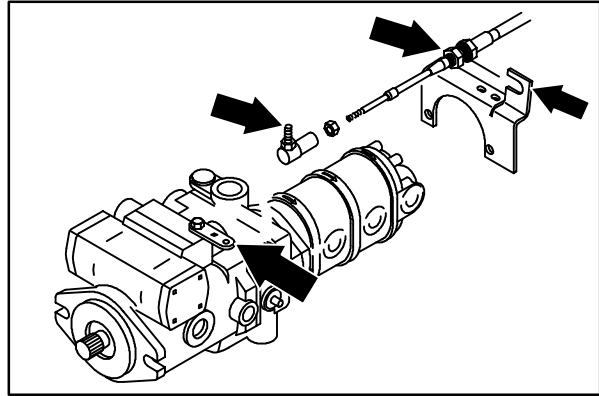

HYDRAULIC COMPONENTS

TO REPLACE PROPEL PUMP

FOR SAFETY: Before Leaving Or Servicing Machine; Stop On Level Surface, Set Parking Brake, Turn Off Machine And Remove Key.

1. Lift the rear drive tire off the ground and place jack stands under the frame.

FOR SAFETY: Block machine tires before jacking machine up. Jack machine up at designated locations only. Block machine up with jack stands.

2. Open the engine cover and side door.
3. Remove the muffler and tail pipe.
4. Disconnect the directional control cable from the propel pump.
5. Remove the two 0.375 in. hex screws holding accessory pump to propel pump.
6. Pull the accessory pump back and out of the propel pump. Leave the hydraulic hoses hooked up to the accessory pump.

NOTE: Be careful not to lose or damage the o-ring on the accessory pump.

7. Position the accessory pump and control cable bracket up and out of the way to ease removal of the propel pump.

NOTE: Mark the hoses that are connected to the propel pump with tape or some other marking device to make sure they are returned to the correct fitting.

8. Remove and plug the hydraulic hoses leading to the propel pump.

NOTE: Observe hydraulic cleanliness requirements when opening hydraulic lines.

9. Remove the two M12 hex screws holding the propel pump to the flywheel housing.

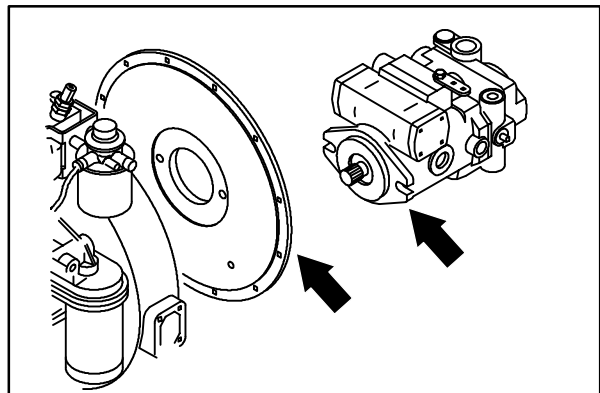
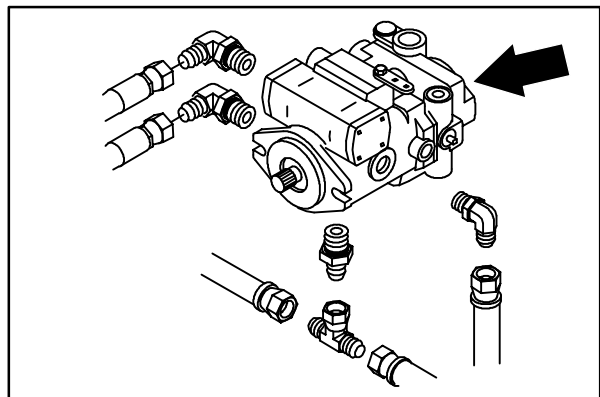
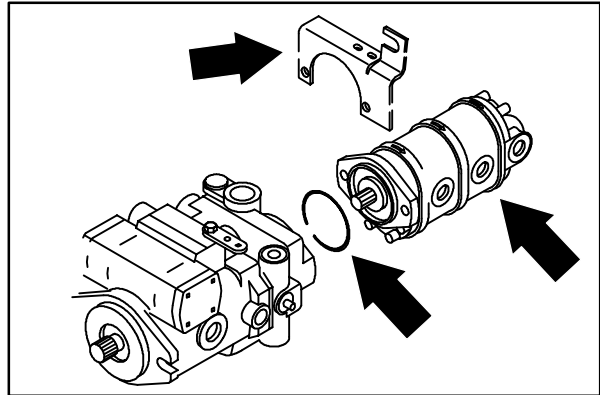
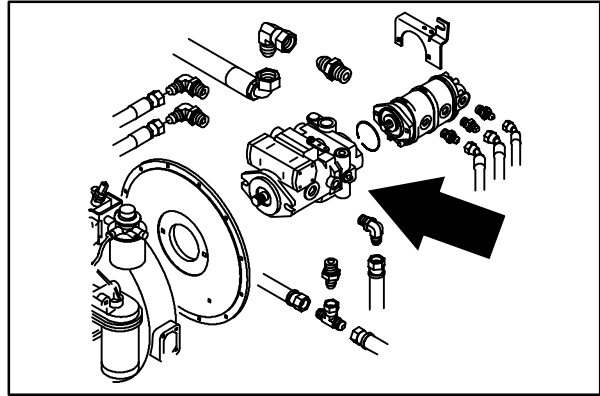

10. Pull the propel pump back and out of the flywheel coupling. The pump must be dropped down and out of the machine between engine the cradle and rear frame.
11. Install the fittings from old pump into the new pump.

NOTE: Make sure to install the fittings in the same orientation as they were removed.

12. Put a small amount of grease on splines of the new pump.
13. Position the new pump in machine. The new pump must be brought under machine and up between the rear frame and engine cradle.
14. Line up the splines on pump shaft with the splines in the flywheel coupling. Push the pump in and reinstall the two M12 hex screws. Tighten to 64 - 83 Nm (50 - 60 ft lb).
15. Reconnect the hydraulic hoses to the new propel pump. See the schematic in this section.

16. Reinstall the accessory pump and control cable mount bracket to the rear of the propel pump.

NOTE: Be sure the o-ring is in place on the accessory pump.

17. Reinstall the two 0.375 in. hex screws. Tighten to 36 - 47 Nm (27 - 35 ft lb).
18. Reconnect the directional control cable to the propel pump.
19. Reinstall the muffler and tail pipe.
20. Start machine and check for any leaks at the propel pump. Close the engine cover and side door.
21. Observe the rear tire for any rotation. If the tire is rotating in either direction see TO ADJUST DIRECTIONAL CONTROL instructions in this section.

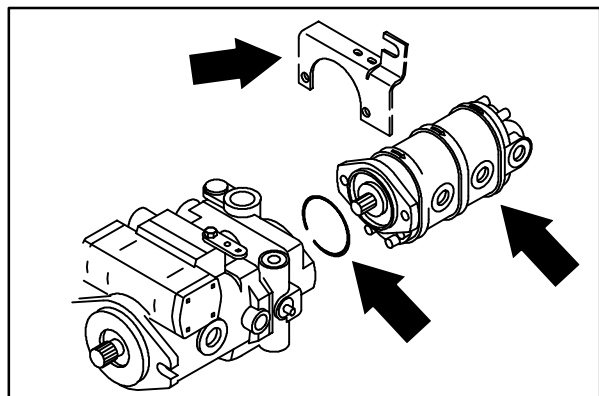
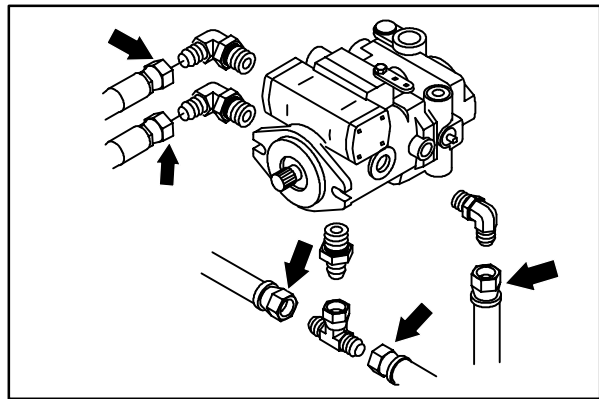
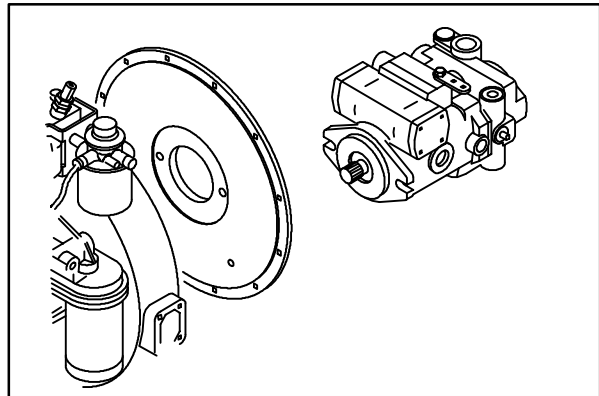
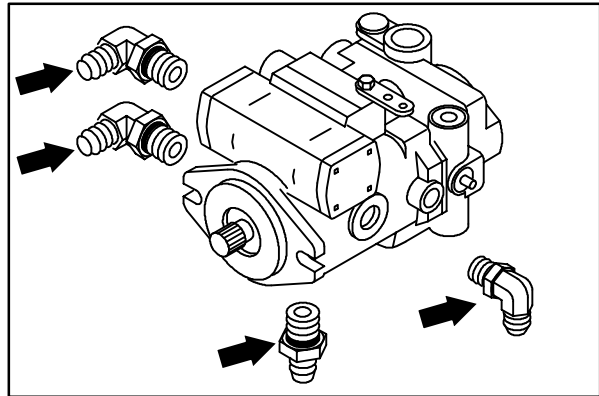

HYDRAULICS

TO REPLACE ACCESSORY PUMP

FOR SAFETY: Before Leaving Or Servicing Machine; Stop On Level Surface, Set Parking Brake, Turn Off Machine And Remove Key.

1. Lift the rear drive tire off the ground and place jack stands under the frame.

FOR SAFETY: Block machine tires before jacking machine up. Jack machine up at designated locations only. Block machine up with jack stands.

2. Open the engine cover and side door.
3. Remove the muffler and tail pipe.

NOTE: Mark the hoses that are connected to the accessory pump with tape or some other marking device to make sure they are returned to the correct fitting.

4. Remove and plug hydraulic hoses leading to the accessory pump.

NOTE: Observe hydraulic cleanliness requirements when opening hydraulic lines.

5. Remove the two 0.375 in. hex screws holding the accessory pump to the propel pump.
6. Place the control cable bracket up and out of the way to ease the removal of the accessory pump.
7. Pull the accessory pump back and out of the propel pump. The accessory pump must be dropped down and out of the machine between the engine cradle and rear frame.

NOTE: Be careful not to lose or damage the o-ring on the accessory pump.

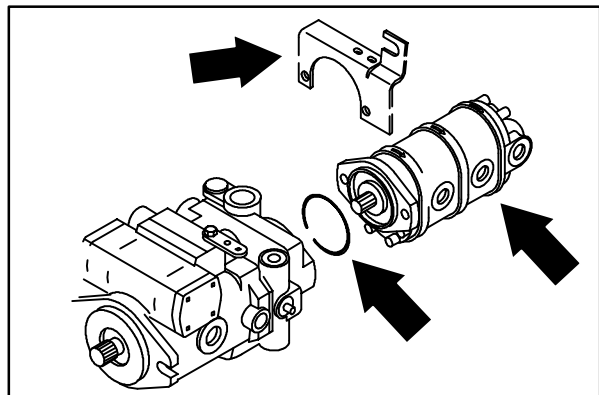
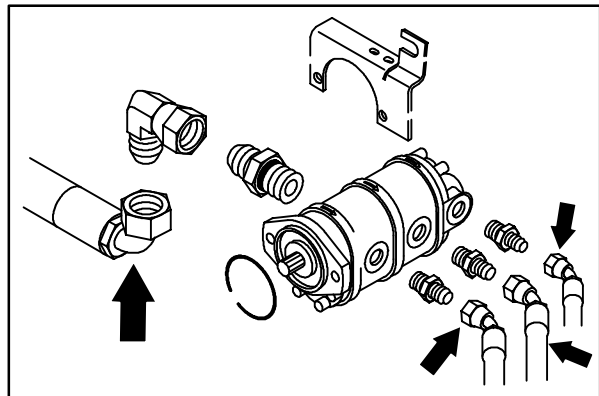
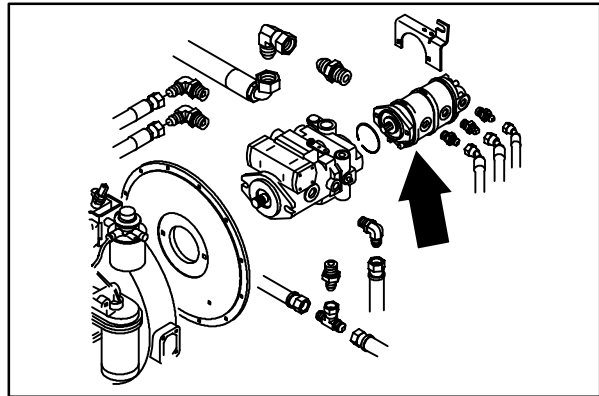

- Remove the fittings from the old accessory pump and install in the new or rebuilt pump.

NOTE: Make sure to install the fittings in the same orientation as they were removed.

- Put a small amount of grease on splines of the new pump.
- Position the new pump in machine. The new pump must be brought under machine and up between the rear frame and engine cradle.
- Reinstall the accessory pump and control cable mount bracket to the rear of the propel pump.

NOTE: Be sure the o-ring is in place on the accessory pump.

- Reinstall the two 0.375 in. hex screws. Tighten to 36 - 47 Nm (27 - 35 ft lb).
- Reconnect the hydraulic hoses to the new accessory pump. See the schematic in this section.
- Reinstall the muffler and tail pipe.
- Start machine and check for any leaks at the propel pump. Close the engine cover and side door.
- Observe the rear tire for any rotation. If the tire is rotating in either direction see TO ADJUST DIRECTIONAL CONTROL instructions in this section.

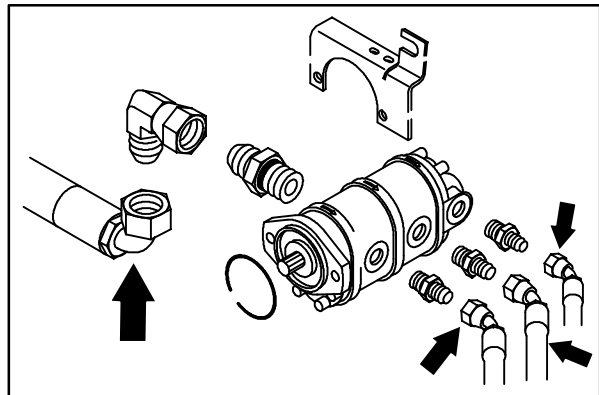
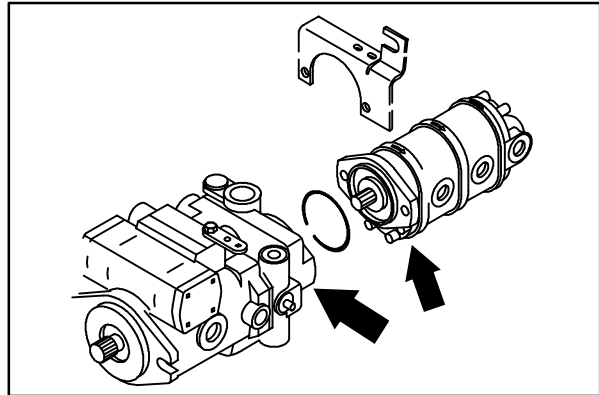
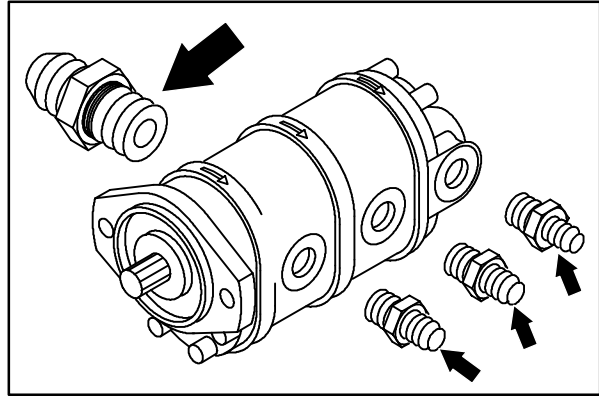

HYDRAULICS

TO REPLACE HOPPER LIFT CYLINDER

FOR SAFETY: Before Leaving Or Servicing Machine; Stop On Level Surface, Set Parking Brake, Turn Off Machine And Remove Key.

1. Raise the hopper and engage the prop arm.

⚠ WARNING: Raised Hopper May Fall. Engage Hopper Support Bar.

2. Remove the M10 hex screw holding the clevis pin in upper rod end of the hopper lift cylinder. Remove the pin.

NOTE: Mark the hoses that are connected to the hopper lift cylinder with tape or some other marking device to make sure they are returned to the correct fitting.

3. Remove and plug the two hydraulic hoses leading to the lift cylinder.

NOTE: Observe hydraulic cleanliness requirements when opening hydraulic lines.

4. Open the engine cover and side door.
5. Remove the inner snap ring from the clevis pin on lower piston end of the lift cylinder.
6. Pull the pin out toward the engine.
7. The cylinder can now be removed out the front of the machine.
8. If a new or rebuilt cylinder is going to be installed, remove the fittings and rod end clevis from the old cylinder.

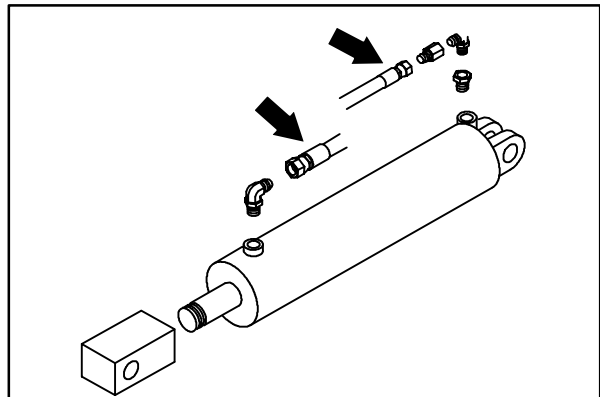
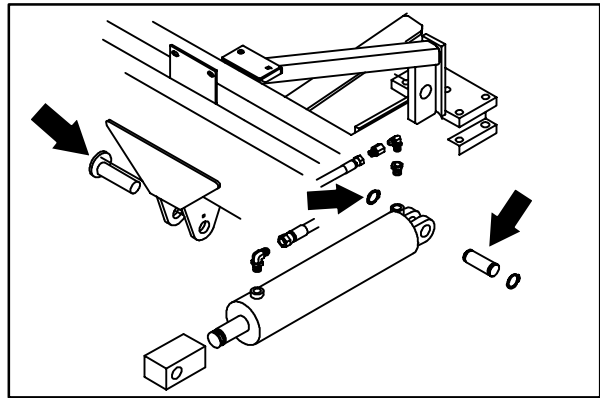
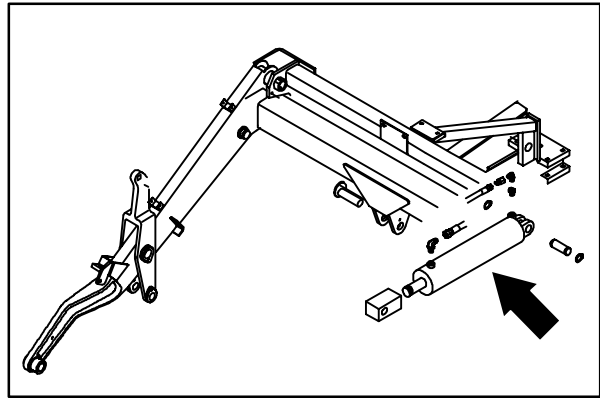

9. Reinstall the fittings and clevis on the new cylinder.

NOTE: Make sure to install the fittings in the same orientation as they were removed.

10. Position the new cylinder back in machine. Reinstall the rear clevis pin and snap ring first.
11. Align the upper clevis with hole in hopper arm lift lug. Reinstall the clevis pin and M10 hex screw. Tighten to 52 - 67 Nm (40 - 50 ft lb).
12. Reconnect the hydraulic hoses to the new hopper lift cylinder. See the schematic in this section.
13. Start the machine and lift the hopper. Check for any leaks.
14. Close the engine cover and side door.
15. Disengage the prop arm and lower the hopper. Operate the machine and check for proper operation.

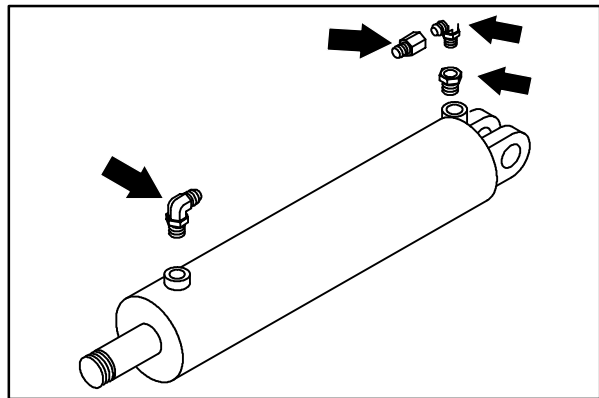
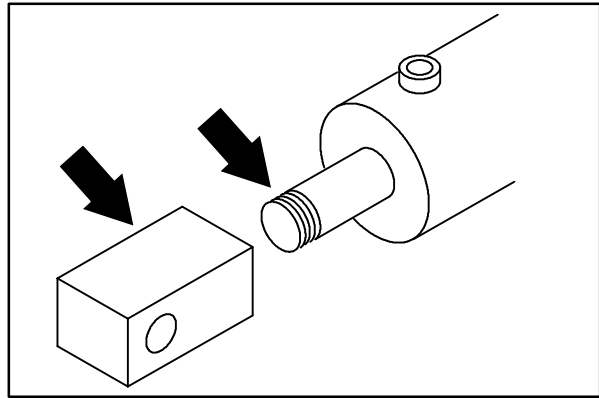

HYDRAULICS

TO REPLACE STEERING CYLINDER

FOR SAFETY: Before Leaving Or Servicing Machine; Stop On Level Surface, Set Parking Brake, Turn Off Machine And Remove Key.

1. Raise the hopper and engage the prop arm.

⚠ WARNING: Raised Hopper May Fall. Engage Hopper Support Bar.

2. Lift the rear drive tire off the ground and place jack stands under the frame.

FOR SAFETY: Block machine tires before jacking machine up. Jack machine up at designated locations only. Block machine up with jack stands.

3. Tilt the seat forward and remove both access panels.

NOTE: Mark the hoses that are connected to the steering cylinder with tape or some other marking device to make sure they are returned to the correct fitting.

4. Remove and plug the two hydraulic hoses leading to the steering cylinder.

NOTE: Observe hydraulic cleanliness requirements when opening hydraulic lines.

5. Remove the two 0.75 in. hex screws and nyloc nuts attaching the steering cylinder to the machine frame and the rear drive casting steering bracket.
6. The steering cylinder can now be removed out the front of the machine.

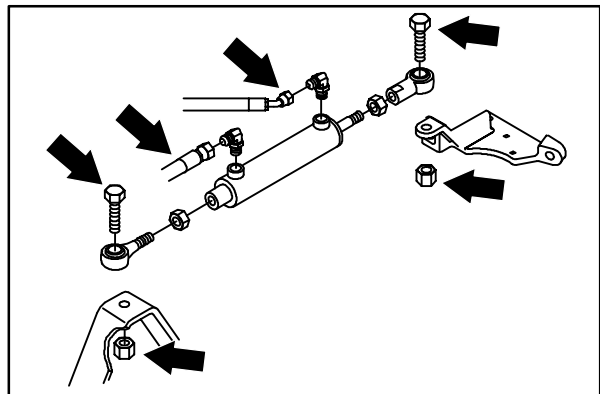
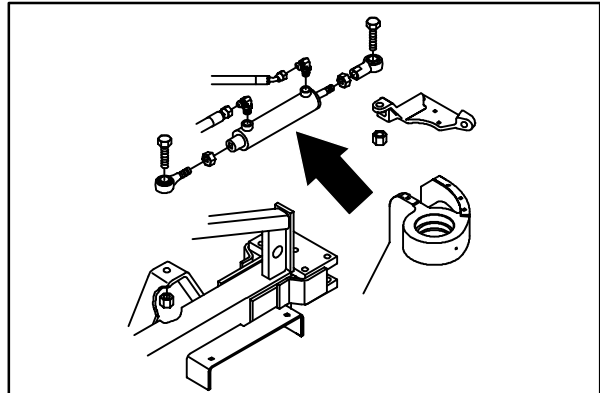
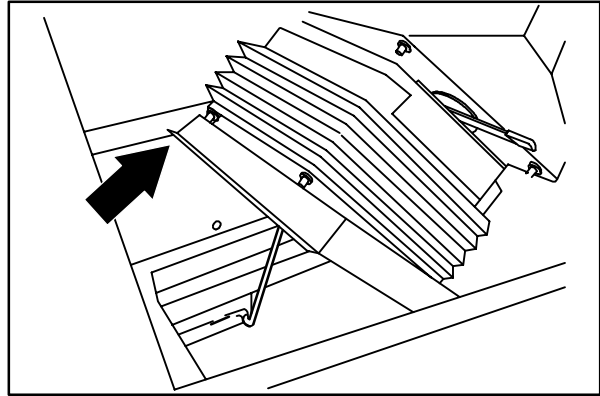

7. If a new or rebuilt cylinder is going to be installed, remove the fittings and ball joint ends from the old cylinder.

NOTE: Measure the ball joint center line distance for proper installation on new cylinder.

8. Reinstall the fittings on the new cylinder.

NOTE: Make sure to install the fittings in the same orientation as they were removed.

9. Position the new steering cylinder in the machine. Reinstall two 0.75 in. hex screws and nyloc nuts. Tighten to 290 - 380 Nm (215 - 280 ft lb).

10. Reconnect the hydraulic hoses to the new steering cylinder. See schematic in this section.
11. Reinstall the two access panels. Tighten the M6 pan head screws to 11 - 14 Nm (7 - 10 ft lb).
12. Start the machine and turn the steering wheel in both directions. Check for any leaks and proper operation of the steering cylinder.
13. Remove the jack stands and lower the machine.
14. Disengage the prop arm and lower the hopper.

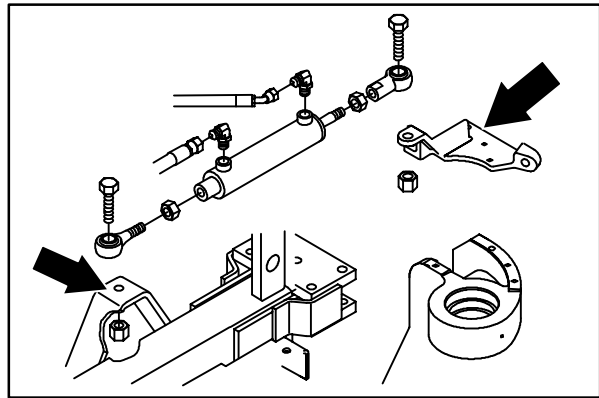
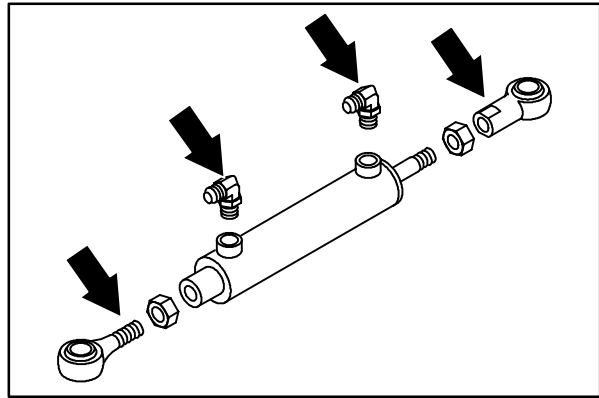

HYDRAULICS

TO REPLACE HOPPER ROLL OUT CYLINDERS

FOR SAFETY: Before Leaving Or Servicing Machine; Stop On Level Surface, Set Parking Brake, Turn Off Machine And Remove Key.

1. Raise the hopper and engage the prop arm.

⚠ WARNING: Raised Hopper May Fall. Engage Hopper Support Bar.

2. Remove the two M8 hex screws holding each fender to front bumper. Disengage the prop arm and lower the hopper.
3. Open the hopper cover and remove the eight M8 hex screws attaching the LH and RH fenders to the hopper.
4. Open the front headlight panel and remove it by spreading the fenders apart. Remove the fenders from the machine.

NOTE: Mark the hoses that are connected to the hopper roll out cylinder with tape or some other marking device to make sure they are returned to the correct fitting.

5. Remove and plug the two hydraulic hoses leading to the hopper roll out cylinder.

NOTE: Observe hydraulic cleanliness requirements when opening hydraulic lines.

6. Remove the M6 hex screw from the pin in the rod end clevis of the roll out cylinder. Remove the pin.
7. Pull the hair pin out of cylinder piston end clevis. Remove the pin. Remove the cylinder from the machine lift arm.
8. If a new or rebuilt cylinder is going to be installed, remove the fittings and clevis end from the old cylinder.

NOTE: Measure the location of clevis on old cylinder and install in same location on new cylinder.

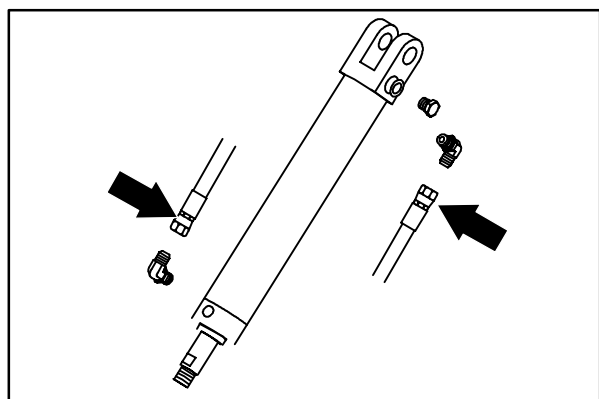
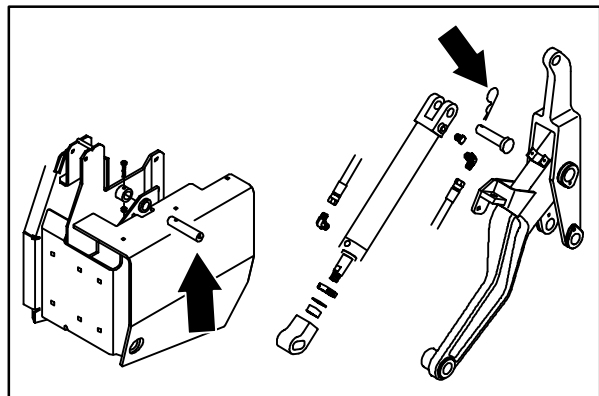
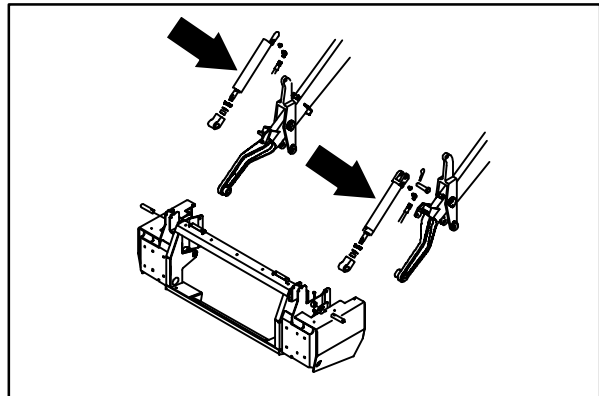
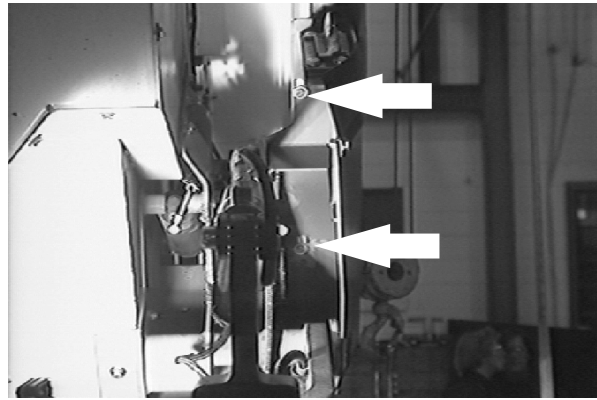

- Reinstall the fittings on the new cylinder.

NOTE: Make sure to install the fittings in the same orientation as they were removed.

- Position the new roll out cylinder on the machine lift arm. Reinstall the upper clevis pin and hair pin.
- Reinstall the lower pin and M6 hex screw. Tighten to 11 - 14 Nm (7 - 10 ft lb).
- Reconnect the hydraulic hoses to the new roll out cylinder. See the schematic in this section.
- Repeat steps 5 - 12 on the other side of the machine if replacing both the roll out cylinders.
- Reinstall the front panel and the RH and LH fenders. Tighten the M8 hex screws to 18 - 24 Nm (13 - 18 ft lb).
- Raise the hopper and engage the prop arm.

! WARNING: Raised Hopper May Fall. Engage Hopper Support Bar.

- Reinstall the two M8 hex screws in bottom of each fender. Tighten to 18 - 24 Nm (13 - 18 ft lb).
- Disengage the prop arm and lower the hopper.
- Start the machine and roll the hopper in and out a few times. Check for any leaks.

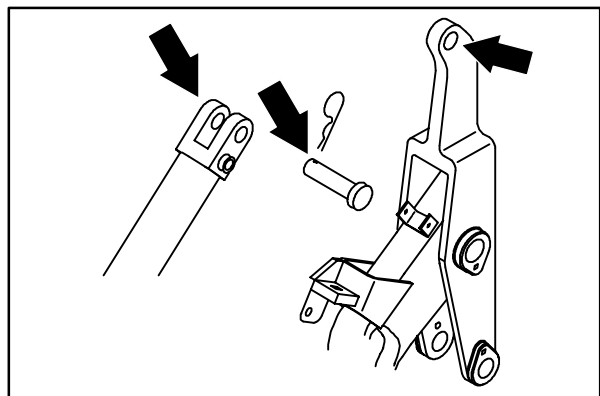
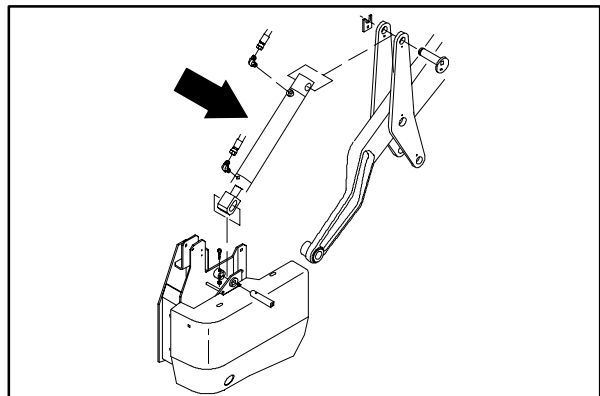
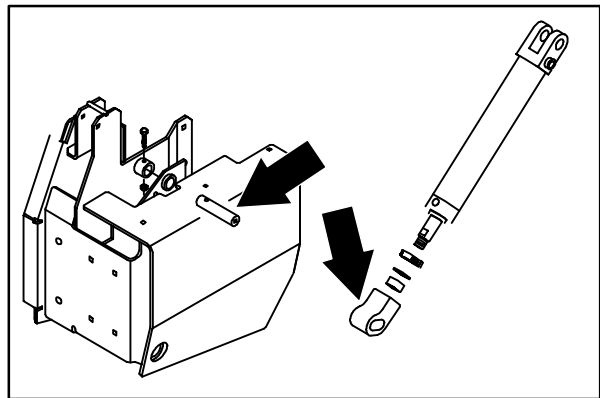
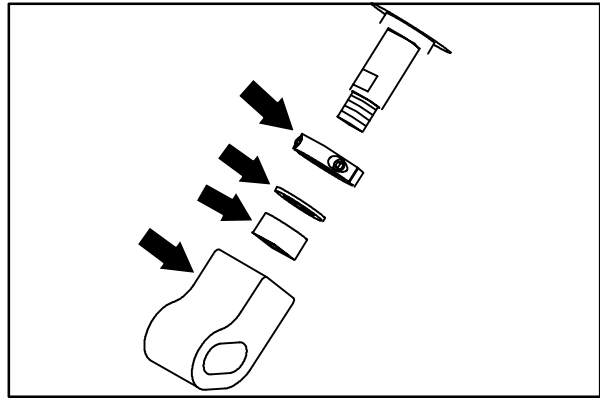

HYDRAULICS

TO REPLACE HOPPER DUMP DOOR CYLINDERS

FOR SAFETY: Before Leaving Or Servicing Machine; Stop On Level Surface, Set Parking Brake, Turn Off Machine And Remove Key.

1. Raise the hopper and engage the prop arm.

⚠ WARNING: Raised Hopper May Fall. Engage Hopper Support Bar.

2. Remove the two M8 hex screws holding each fender to front bumper. Disengage the prop arm and lower the hopper.
3. Open the hopper cover and remove the eight M8 hex screws attaching the LH and RH fenders to the hopper.
4. Open the front headlight panel and remove it by spreading the fenders apart. Remove the fenders from the machine.
5. Start the engine and open the dump door.

NOTE: Remove only one cylinder at a time with the dump door open.

6. Remove and plug the two hydraulic hoses leading to the dump door cylinder.

NOTE: Observe hydraulic cleanliness requirements when opening hydraulic lines.

7. Remove the M8 hex screw holding the lower cylinder clevis pin. Remove the pin.
8. Remove the cotter pin and clevis pin from the rod end of dump door cylinder. Remove the cylinder from the machine.
9. If a new or rebuilt cylinder is going to be installed, remove the fittings from the old cylinder.

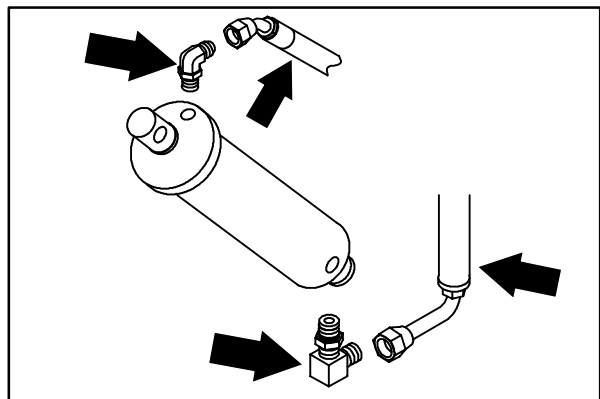
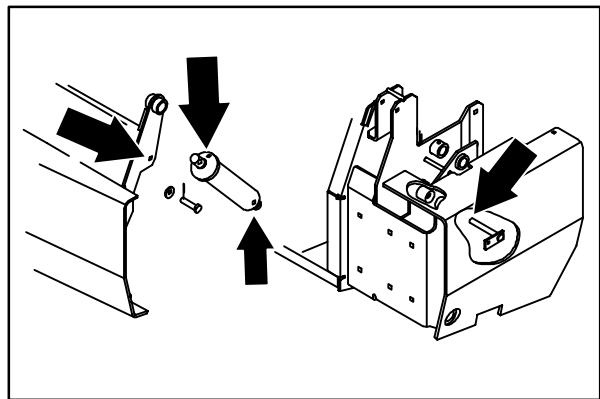
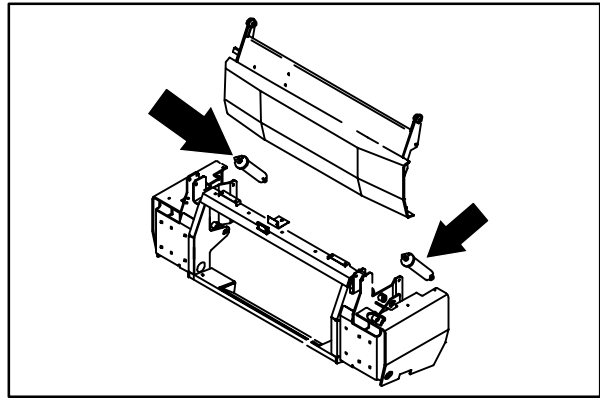

10. Reinstall the fittings on the new cylinder.

NOTE: Make sure to install the fittings in the same orientation as they were removed.

11. Install cylinder back in the machine.
Reinstall both pins using the cotter pin and M8 hex screw. Tighten the screw to 26 - 34 Nm (19 - 25 ft lb).
12. Reconnect the hydraulic hoses to the new dump door cylinder. See the schematic in this section.

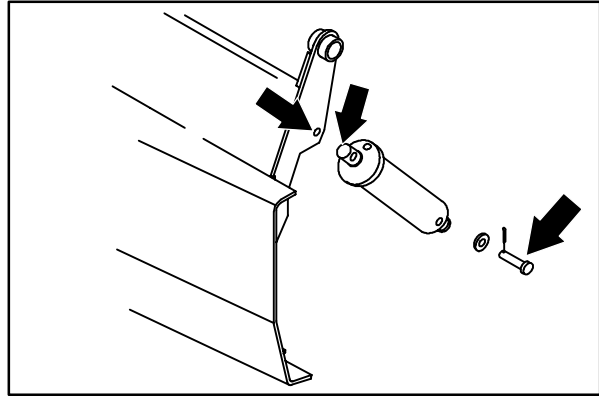

13. Repeat steps 6 - 12 on the other side of the machine if replacing both cylinders.
14. Reinstall the front panel and the RH and LH fenders. Tighten the M8 hex screws to 18 - 24 Nm (13 - 18 ft lb).
15. Raise the hopper and engage the prop arm.

⚠ WARNING: Raised Hopper May Fall. Engage Hopper Support Bar.

16. Reinstall the two M8 hex screws in bottom of each fender. Tighten to 18 - 24 Nm (13 - 18 ft lb).
17. Disengage the prop arm and lower the hopper.
18. Start the machine and open the dump door a few times. Check for any leaks.

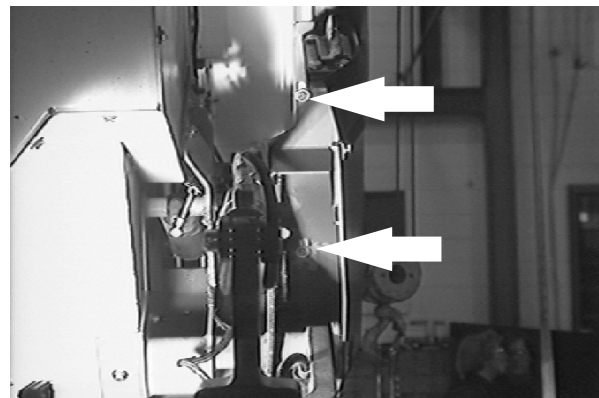
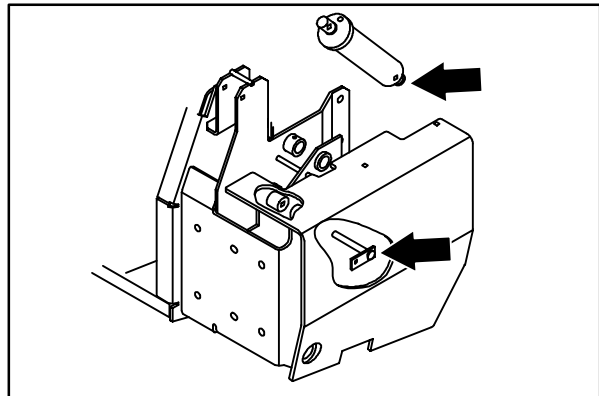

HYDRAULICS

TO REPLACE MAIN BRUSH LIFT CYLINDER

FOR SAFETY: Before Leaving Or Servicing Machine; Stop On Level Surface, Set Parking Brake., Turn Off Machine And Remove Key.

1. Jack up the rear of the machine.

FOR SAFETY: Block machine tires before jacking machine up. Jack machine up at designated locations only. Block machine up with jack stands.

2. Open the engine cover and side door.
3. Remove the muffler and tail pipe.
4. Disconnect the main brush lift cable at the cylinder bracket.

NOTE: Mark the hoses that are connected to the lift cylinder with tape or some other marking device to make sure they are returned to the correct fitting.

5. Remove and plug the two hydraulic hoses on the main brush lift cylinder.

NOTE: Observe hydraulic cleanliness requirements when opening hydraulic lines.

6. Remove the two large tension springs from the white plastic retainer tubes.

NOTE: Make sure cylinder is all the way retracted before removing springs.

7. Remove the cotter pin from the clevis holding lift cylinder to the mount bracket. The cylinder can now be removed from the machine.
8. Remove one 0.50 in. hex nut from the threaded rod holding plastic spring tubes to the lift cylinder.

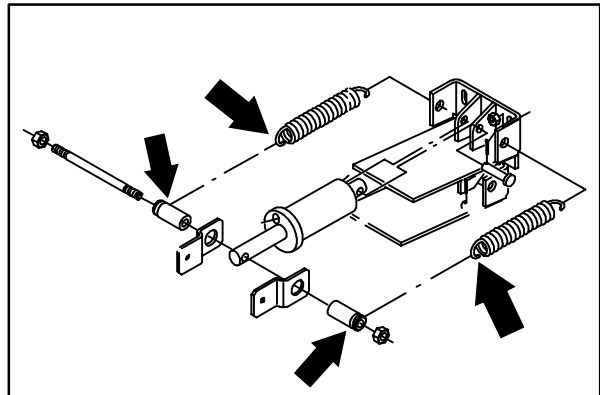
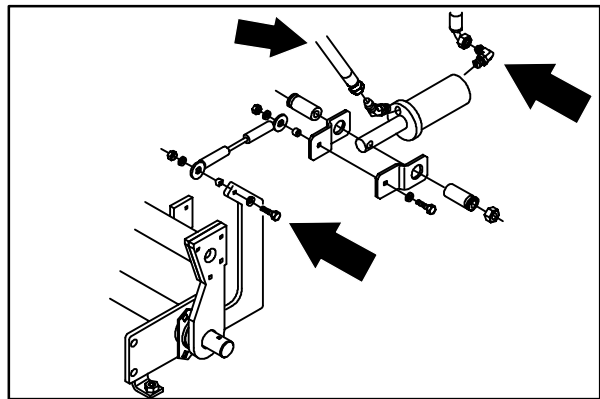
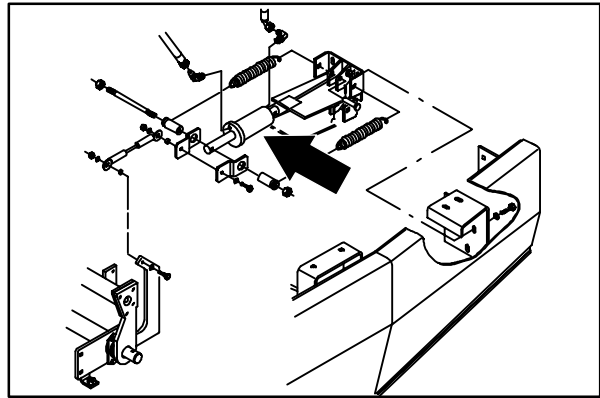

9. Remove rod, plastic tubes, and cable bracket from old cylinder and install on the new cylinder. Hand tighten the 0.50 in. hex nut. Use a small amount 242 blue loctite on threads.
10. Remove the fittings from the old cylinder and install in the new one.

NOTE: Remember to orientate the fittings as close as possible to the way they came out.

11. Position the new lift cylinder assembly back in machine from underneath. Install the clevis and cotter pin.
12. Reconnect both tension springs to the plastic spring tubes.

NOTE: Make sure cylinder is all the way retracted before installing springs.

13. Reconnect the hydraulic hoses to the brush lift cylinder. See the schematic in this section.
14. Reconnect the main brush lift cable to the cylinder bracket. Tighten the M8 hex bolt to 18 - 24 Nm (13 - 18 ft lb).
15. Reinstall the muffler and tail pipe.
16. Start engine and check for any leaks.

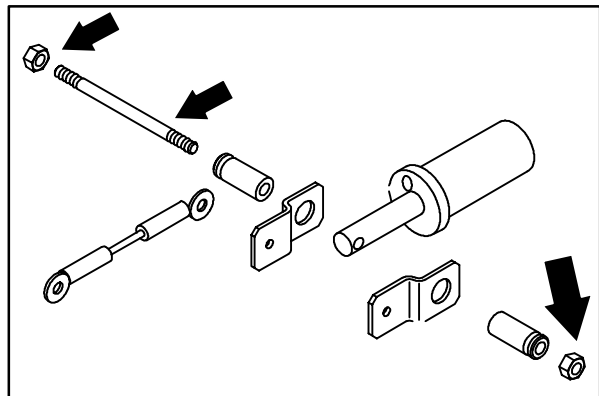
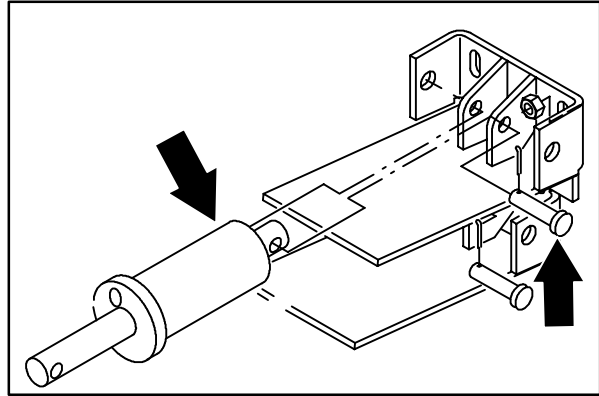

HYDRAULICS

TO REPLACE SIDE BRUSH LIFT CYLINDER

FOR SAFETY: Before Leaving Or Servicing Machine; Stop On Level Surface, Set Parking Brake, Turn Off Machine And Remove Key.

1. Raise the hopper and engage the prop arm.

⚠ WARNING: Raised Hopper May Fall. Engage Hopper Support Bar.

2. Turn off the engine and engage the parking brake.
3. Remove the M10 hex screw holding the side brush, hopper up, lift cable to the lift arm.
4. Let the side brush drop down on the stop.
5. Remove the M10 hex screw holding the side brush lift cable to the side brush assembly.

NOTE: Mark the hoses at the lift cylinder so they can be reinstalled to the correct port.

6. Disconnect and plug the two hydraulic hoses leading to the side brush lift cylinder.

NOTE: Observe hydraulic cleanliness requirements when opening hydraulic lines.

7. Remove the M10 hex screw, nyloc nut and spacer from the piston end of the side brush lift cylinder at the upper frame bracket.
8. Remove the cotter pin from the 0.375 clevis pin connecting the rod end of the side brush lift cylinder to the pivot brackets.

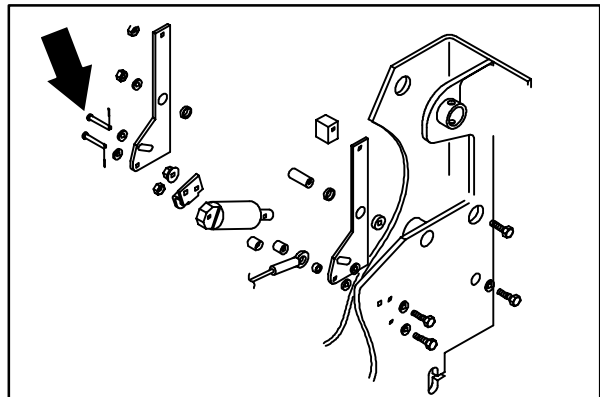
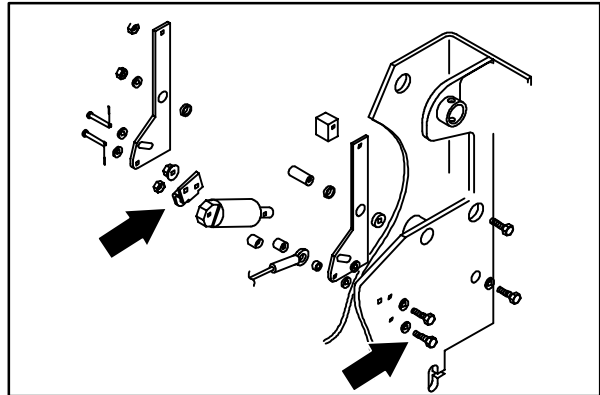
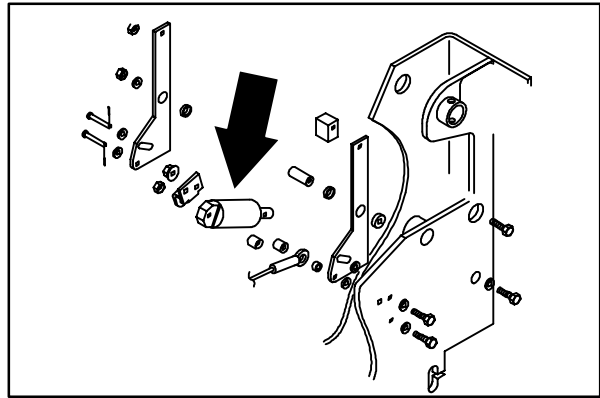

9. The side brush lift cylinder can now be removed from the machine.
10. Remove the fittings from the old cylinder and install into the new cylinder making sure to keep the orientation the same.

NOTE: Remember to orientate the fittings as close as possible to the way they came out.

11. Position the new cylinder back in the machine, rod end first.
12. Reinstall the 0.375 clevis pin back through the pivot plate and the hole in the end of the cylinder rod. Reinstall the cotter pin.
13. Position the piston end of the cylinder back into the upper frame bracket. Reinstall the M10 hex screw, spacer, and nyloc nut. Hand tighten.
14. Reconnect the two hydraulic hoses to the cylinder. See schematic in this section.
15. Reconnect the side brush lift cable to the side brush assembly. Tighten the M10 hex screw to 37 - 48 Nm (26 - 34 ft lb).
16. Lift the side brush assembly up and reconnect the side brush, hopper up, lift cable to the lift arm. Tighten the M10 hex screw to 37 - 48 Nm (26 - 34 ft lb).
17. Start the machine, lower hopper, and check the side brush lift cylinder for any leaks and proper operation.

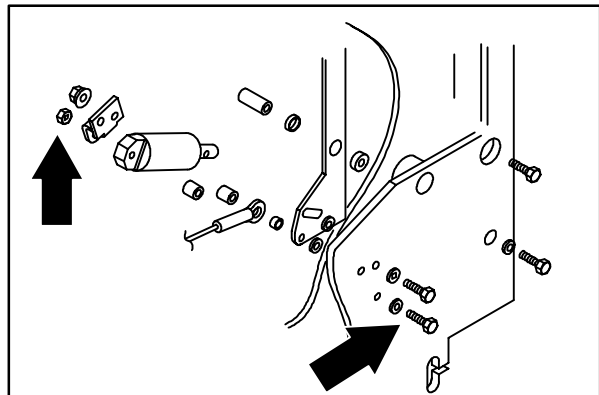
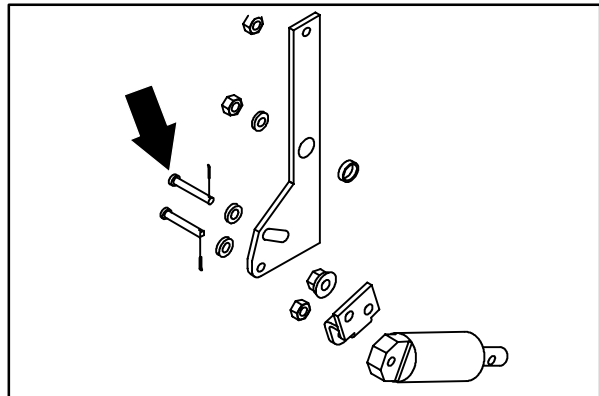
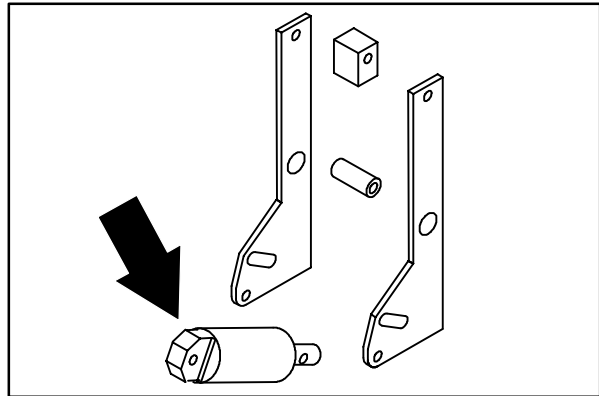

HYDRAULICS

TO REPLACE POWER THROW™ BRUSH LIFT CYLINDER

FOR SAFETY: Before Leaving Or Servicing Machine; Stop On Level Surface, Set Parking Brake., Turn Off Machine And Remove Key.

1. Jack up the rear of the machine.

FOR SAFETY: Block machine tires before jacking machine up. Jack machine up at designated locations only. Block machine up with jack stands.

2. Open the engine cover and side door.
3. Remove the muffler and tail pipe.
4. Disconnect the POWER THROW™ brush lift cable at the cylinder bracket.

NOTE: Mark the hoses that are connected to the lift cylinder with tape or some other marking device to make sure they are returned to the correct fitting.

5. Remove and plug the two hydraulic hoses leading to the POWER THROW™ brush lift cylinder.

NOTE: Observe hydraulic cleanliness requirements when opening hydraulic lines.

6. Remove the two large tension springs from the white plastic retainer tubes.

NOTE: Make sure cylinder is all the way retracted before removing springs.

7. Remove the cotter pin from the clevis holding lift cylinder to the mount bracket. The cylinder can now be removed from the machine.
8. Remove one 0.50 in. hex nut from the threaded rod holding plastic spring tubes to the lift cylinder.

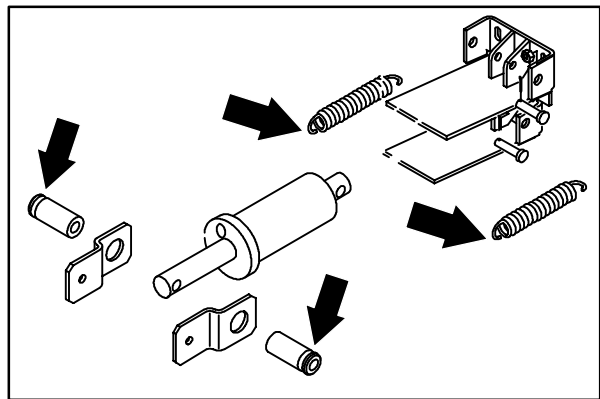
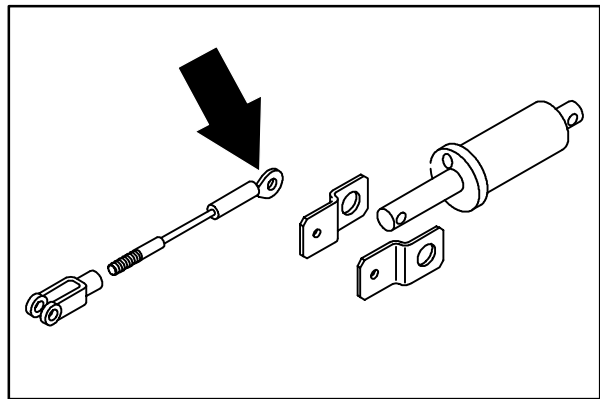
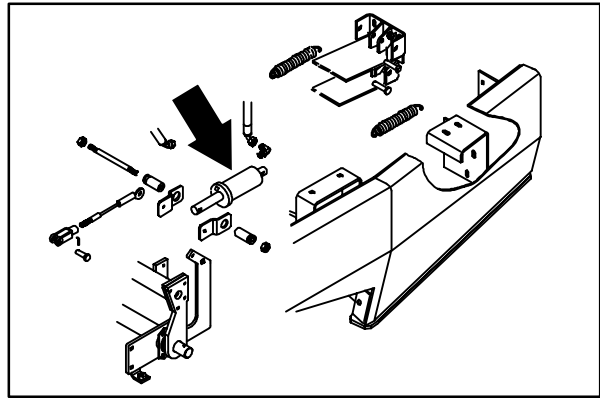

9. Remove rod, plastic tubes, and cable bracket from old cylinder and install on the new cylinder. Hand tighten the 0.50 in. hex nut. Use a small amount 242 blue loctite on threads.
10. Remove the fittings from the old cylinder and install in the new one.

NOTE: Remember to orientate the fittings as close as possible to the way they came out.

11. Position the new POWER THROW™ lift cylinder assembly back in machine from underneath. Install the clevis and cotter pin.
12. Reconnect both tension springs to the plastic spring tubes.

NOTE: Make sure cylinder is all the way retracted before installing springs.

13. Reconnect the hydraulic hoses to the POWER THROW™ lift cylinder. See the schematic in this section.
14. Reconnect the POWER THROW™ brush lift cable to the cylinder bracket. Tighten the M8 hex bolt to 18 - 24 Nm (13 - 18 ft lb).
15. Reinstall the muffler and tail pipe.
16. Start engine and check for any leaks.

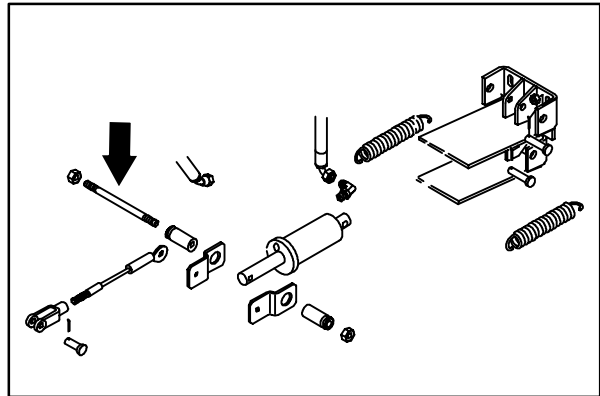
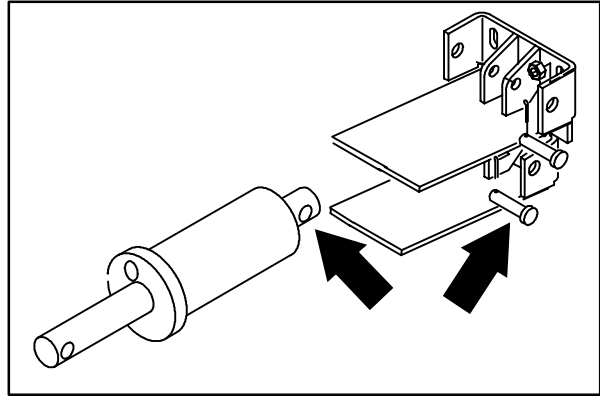

HYDRAULICS

TO REPLACE SIDE BRUSH SOLENOID VALVE

1. Raise the hopper and the engage prop arm.

⚠ WARNING: Raised Hopper May Fall. Engage Hopper Support Bar.

2. Turn off the engine and engage the parking brake.
3. Lift the rubber dust flap located in front of the driver's compartment.

NOTE: Mark the hoses at the solenoid valve so they can be reinstalled to the correct port.

4. Disconnect and plug the six hydraulic hoses leading to the side brush solenoid valve.
5. Un-plug the solenoid valve cartridges from the main electrical harness.

NOTE: Observe hydraulic cleanliness requirements when opening hydraulic lines.

6. Remove the two M6 hex screws, nyloc nuts and rubber washers holding the solenoid valve to the valve bracket. Remove the valve from the machine.
7. Remove the fittings from the old valve and install in the new valve. Make sure to keep the orientation the same.

NOTE: Remember to orientate the fittings as close as possible to the way they came out.

8. Position the new valve back in the machine. Reinstall the two M6 hex screws and nyloc nuts. Make sure that the rubber washers are installed between valve and bracket. Hand tighten the hex screws.
9. Reconnect the six hydraulic hoses to the solenoid valve. See schematic in this section.
10. Reconnect the main harness to the solenoid valve. See schematic in the ELECTRICAL section.
11. Drop rubber dust flap back in place.
12. Start the machine, lower hopper, and check the side brush for proper operation.

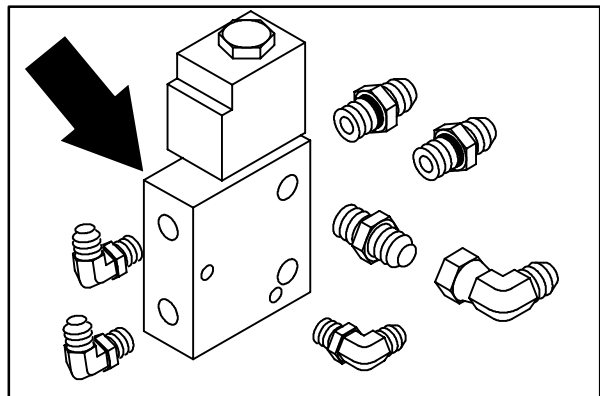
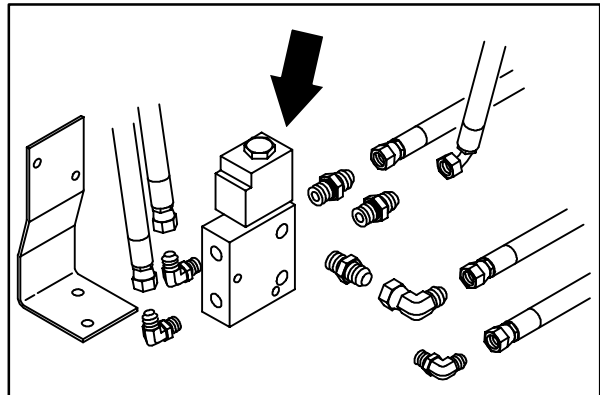
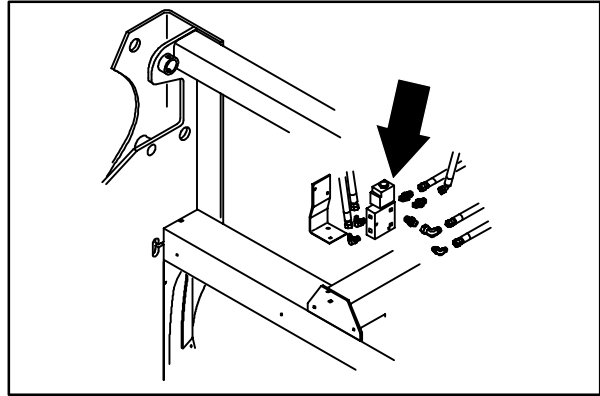

TO REPLACE HYDRAULIC LIFT VALVE

FOR SAFETY: Before Leaving Or Servicing Machine; Stop On Level Surface, Set Parking Brake, Turn Off Machine And Remove Key.

1. Raise the hopper and engage the prop arm.

⚠ WARNING: Raised Hopper May Fall. Engage Hopper Support Bar.

2. Turn off engine and engage the parking brake.
3. Remove the battery cables from the battery.
4. Remove the three plastic knobs from the valve handles.
5. Put the steering wheel in the lowest position.
6. Remove the eight M6 pan head screws from dash panel.
7. Pull the dash panel toward the steering wheel until it clears the valve handles.

NOTE: Mark the hoses that are connected to the valve with tape or some other marking device to make sure they are returned to the correct fitting.

8. Remove and plug all the hoses connected to valve.

NOTE: Observe hydraulic cleanliness requirements when opening hydraulic lines.

9. Remove one large clevis pin and three smaller clevis pins attaching the valve handles to valve and mount bracket.
10. Remove the three M6 hex screws, washers, isolators and steel sleeves holding the valve and mount bracket to the machine frame. Remove the valve out the front of of the machine.
11. Remove the two M6 hex screws holding the valve to the mount bracket. Remove the mount bracket.

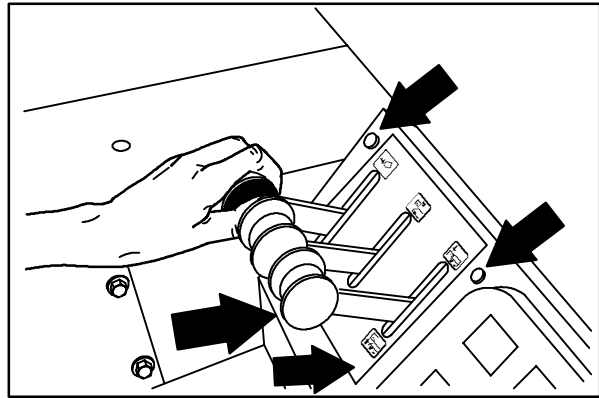

08475

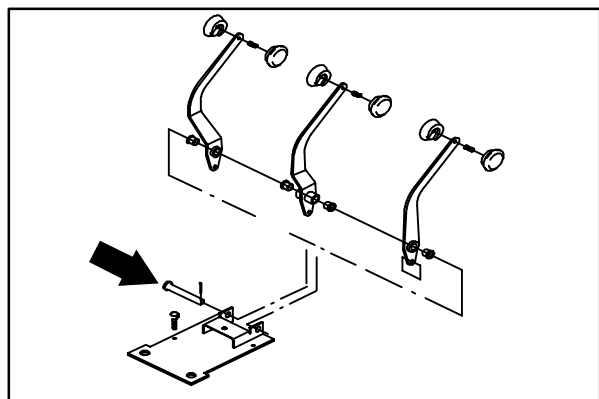
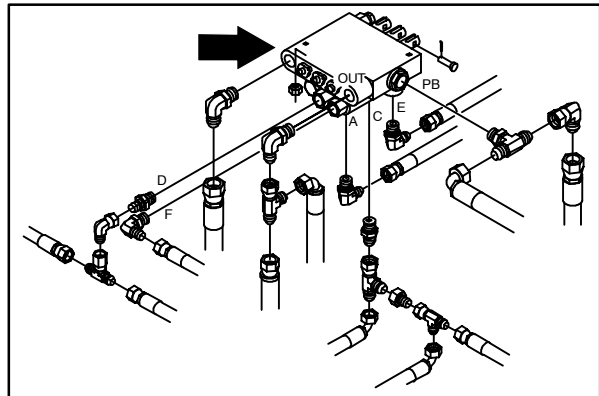
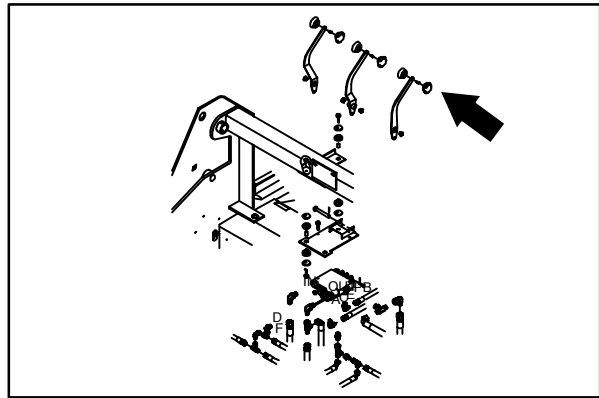

HYDRAULICS

12. Remove the fittings from the old cylinder and install in the new one.

NOTE: Remember to orientate the fittings as close as possible to the way they came out.

13. Reinstall the new valve on the valve bracket using two M6 hex screws. Tighten to 8 - 10 Nm (5 - 7 ft lb).
14. Reinstall the valve and bracket back in the machine through the front. Reinstall the three M6 hex screws, washers, and rubber isolators. Tighten to 8 - 10 Nm (5 - 7 ft lb).

NOTE: Make sure rubber ring is between valve bracket and machine frame.

15. Reinstall the three valve handles using one large clevis pin and three smaller ones.
16. Reconnect the hydraulic hoses to the control valve. See schematic in this section.
17. Reinstall the dash panel on machine using eight M6 pan head screws. Tighten to 8 - 10 Nm (5 - 7 ft lb).
18. Reinstall the three plastic knobs on the valve handles. Lightly hand tighten.
19. Reconnect the battery cables.
20. Start machine and check the new valve for leaks.

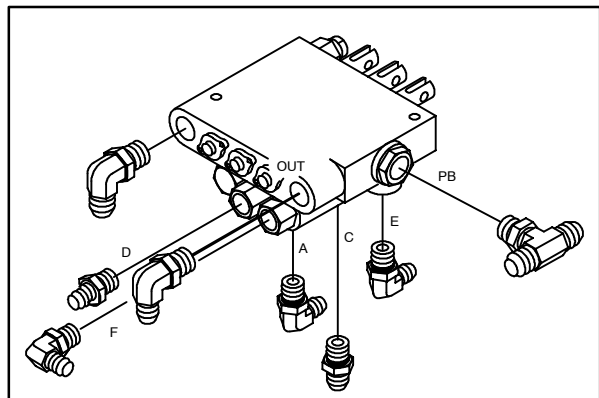
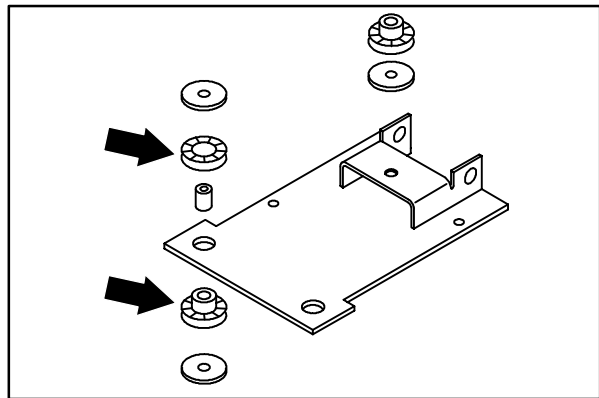
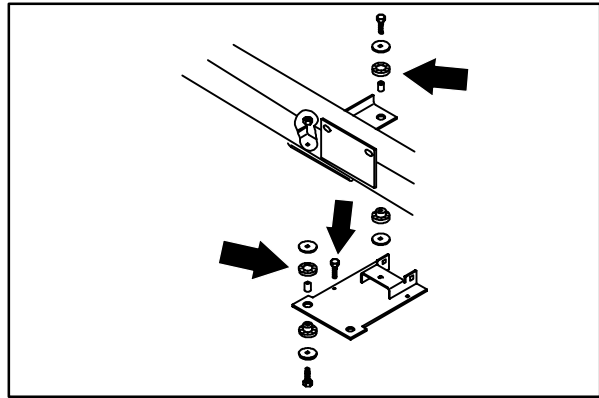

TO REPLACE HYDRAULIC STEERING VALVE

FOR SAFETY: Before Leaving Or Servicing Machine; Stop On Level Surface, Set Parking Brake, Turn Off Machine And Remove Key.

1. Raise the hopper and engage the prop arm.

⚠ WARNING: Raised Hopper May Fall. Engage Hopper Support Bar.

2. Turn off engine and engage the parking brake.
3. Remove the rubber cap from center of the steering wheel.
4. Remove the M12 hex nut holding the steering wheel to the steering column.
5. Remove the steering wheel.

NOTE: A puller may be needed to remove the steering wheel.

6. Lift the rubber dust flap located in front of the driver's compartment.

NOTE: Mark the hoses that are connected to the steering valve with tape or some other marking device to make sure they are returned to the correct fitting.

7. Remove and plug the five hydraulic hoses leading to the steering control motor.

NOTE: Observe hydraulic cleanliness requirements when opening hydraulic lines.

8. Remove the four M6 hex screws holding the two steering bracket pivot bearing in place.
9. Slide the steering column, control motor, and pivot bracket assembly down and out of the machine.

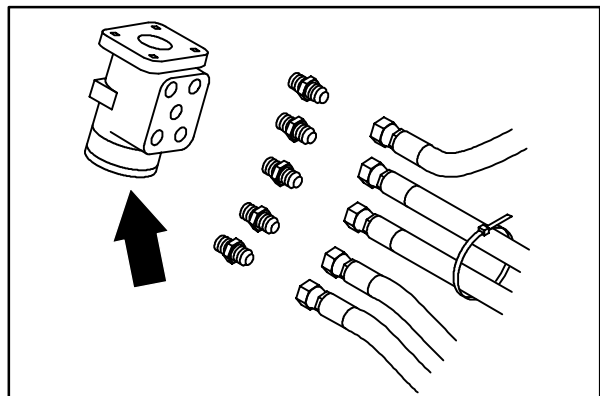
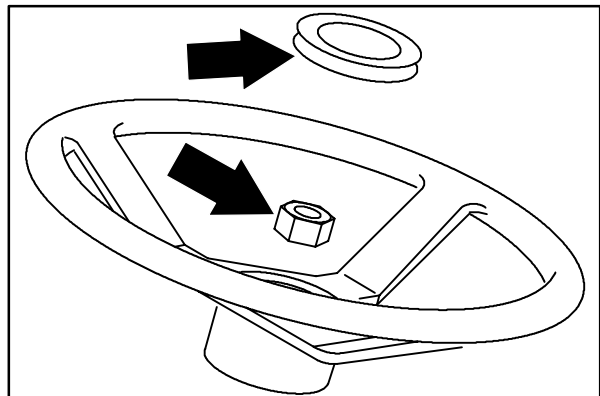
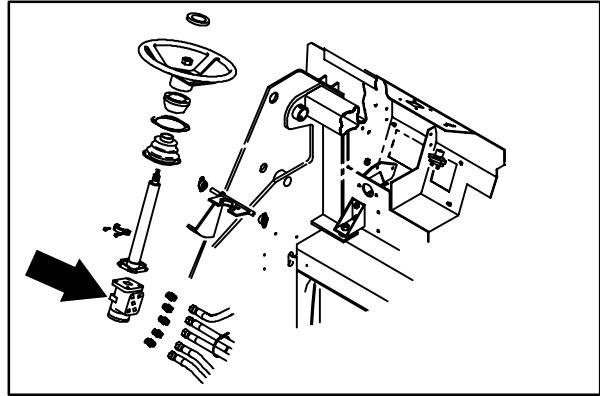

HYDRAULICS

10. Remove the four 0.375 in. screws holding the steering column and pivot bracket to the control motor.

NOTE: There is two different length screws. Note the location of each.

11. Remove the hydraulic fittings from the old control motor and install in new or rebuilt motor.
12. Reinstall the steering column and pivot bracket to the new control motor using the 0.375 in. screws. Tighten to 18 - 24 Nm (13 - 18 ft lb).

NOTE: Make sure to position the pivot bracket in the same location as it was removed from the old control motor.

13. Slide the steering column, control motor, and pivot bracket assembly back in the machine.
14. Reinstall four M6 hex screws holding both steering bracket pivot bearing in place. Tighten to 8 - 10 Nm (6 - 8 ft lb).
15. Reconnect the hydraulic hoses to the new steering control motor. See the schematic in this section.
16. Drop the rubber dust flap back in place.
17. Reinstall steering wheel back on the steering column. Tighten the M12 hex nut to 102 - 132 Nm (75 - 97 ft lb).
18. Reinstall the rubber cap on the steering wheel.
19. Start the engine and check the steering control motor for leaks.

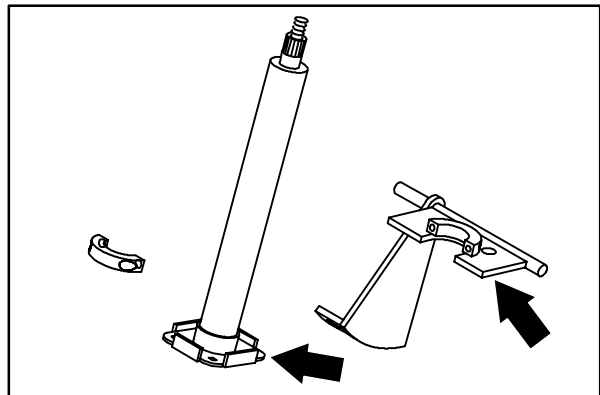
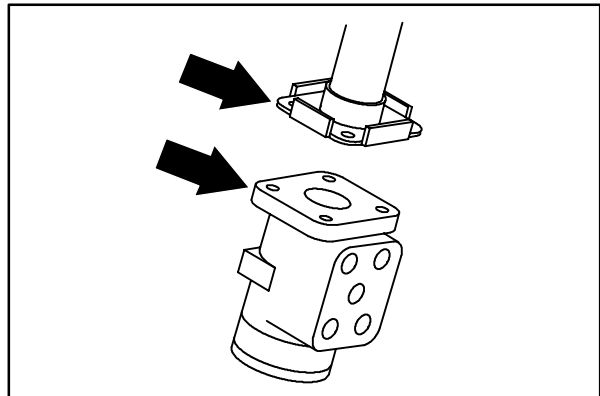
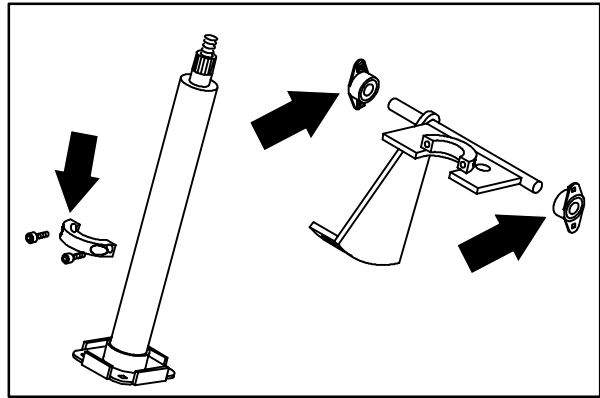

TO REPLACE HYDRAULIC SOLENOID VALVE
FOR SAFETY: Before Leaving Or Servicing Machine; Stop On Level Surface, Set Parking Brake, Turn Off Machine And Remove Key.

1. Raise the hopper and engage the prop arm.

⚠ WARNING: Raised Hopper May Fall. Engage Hopper Support Bar.

2. Turn off the engine and engage the parking brake.
3. Remove the battery cables from the battery.
4. Open the engine cover and side door.
5. Un-plug the four solenoid valve cartridges from the main electrical harness.

NOTE: Mark the hoses that are connected to the valve with tape or some other marking device to make sure they are returned to the correct fitting.

6. Remove and plug the hoses connected to the valve.

NOTE: Observe hydraulic cleanliness requirements when opening hydraulic lines.

7. Remove the two M6 hex screws holding the upper valve mounting bracket to the machine frame.
8. Remove the valve by lifting it up and out of the lower bracket.

NOTE: Be careful not to lose two rubber isolator strips.

9. Remove the three M8 flat head screws holding the valve mounting plate to the valve.

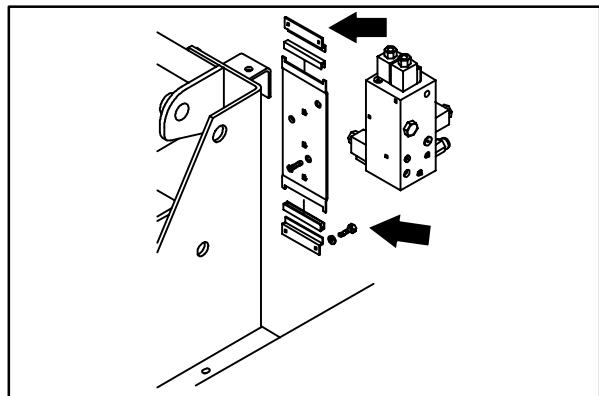
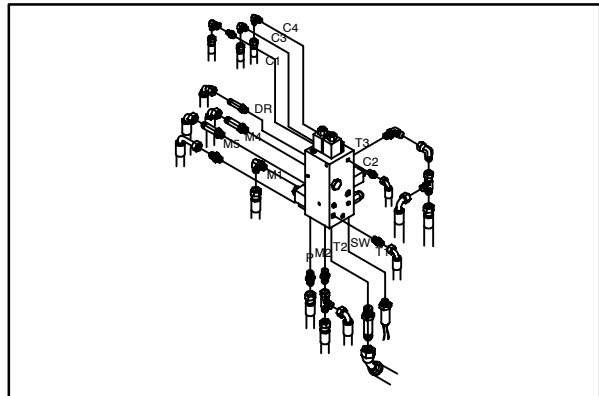
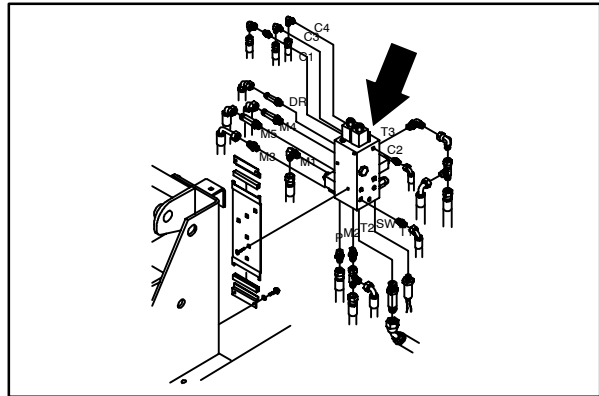

HYDRAULICS

10. Remove the fittings from the old valve and install in the new one.

NOTE: Remember to orientate the fittings as close as possible to the way they came out.

11. Reinstall the new valve on the old valve plate using three M8 flat head screws. Tighten to 18 - 24 Nm (13 - 18 ft lb).
12. Reinstall the valve and mount plate back on the lower mount bracket.

NOTE: Make sure rubber isolator strips are in place.

13. Reinstall the upper valve mount bracket using two M6 hex screws. Tighten to 8 - 10 Nm (5 - 7 ft lb).
14. Reconnect the hydraulic hoses to the new control valve. See schematic in this section.
15. Plug the four solenoid valve cartridges back into the main harness. See schematic in the ELECTRICAL section.
16. Reconnect the battery cables.
17. Start the machine and check for leaks and proper operation of the solenoid valve.

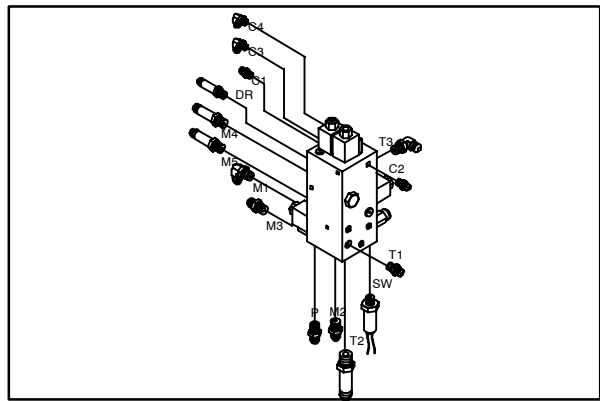
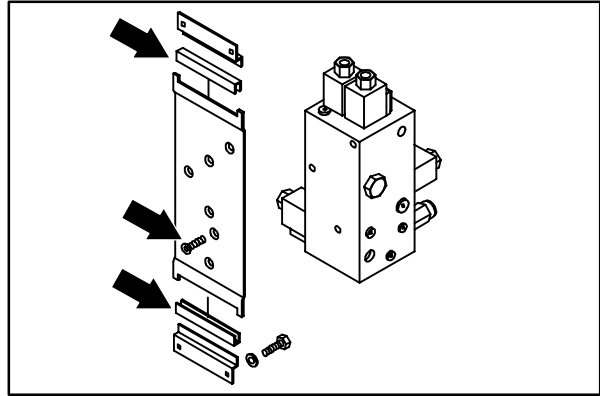

TO REPLACE SOLENOID VALVE CARTRIDGE

FOR SAFETY: Before Leaving Or Servicing Machine; Stop On Level Surface, Set Parking Brake, Turn Off Machine And Remove Key.

1. Turn off the engine and engage the parking brake.
2. Remove the battery cables from the battery.
3. Open the engine cover and side door.
4. Identify the cartridge to be removed from the solenoid valve assembly. Unplug the cartridge from the main harness.
5. Remove the hex nut and rubber o-ring from cartridge stem.
6. Slide the electrical coil and rubber o-ring off the cartridge stem.

NOTE: Hydraulic oil will run out of the valve when cartridge is removed.

7. Loosen and unscrew the cartridge stem out of the valve body.

NOTE: Observe hydraulic cleanliness requirements when opening hydraulic lines.

8. Install a new or rebuilt cartridge stem back in the valve port. Hand tighten. Do not over tighten.

NOTE: Make sure the new cartridge had an o-ring installed and oiled before reinstalling.

9. Slip the o-ring and coil back over the stem.
10. Install the o-ring and hex nut on the stem. Hand tighten. Do not over tighten.

NOTE: Do not over tighten, snug only.

11. Plug the coil back in the main harness. See schematic in the ELECTRICAL section.
12. Reconnect the battery cables.
13. Start the machine and check the cartridge for leaks and proper operation.

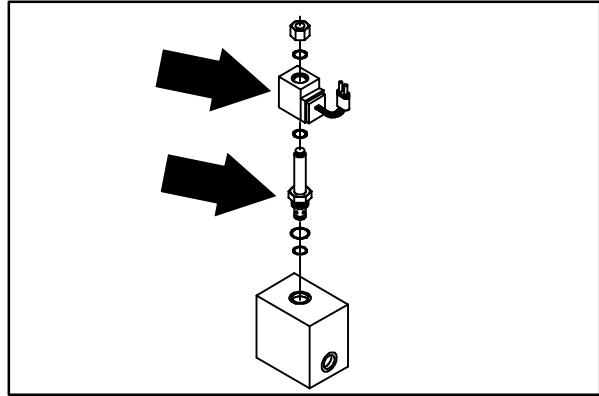

HYDRAULICS

TO REPLACE ENGINE COOLING FAN HYDRAULIC MOTOR

FOR SAFETY: Before Leaving Or Servicing Machine; Stop On Level Surface, Set Parking Brake, Turn Off Machine And Remove Key.

1. Turn off the engine and engage the parking brake.
2. Remove the battery cables from the battery.
3. Open the engine cover and side door.
4. Remove the two springs and hooks holding the fan screen guard to engine fan housing.

NOTE: Mark the hoses that are connected to the fan motor with tape or some other marking device to make sure they are returned to the correct fitting.

5. Remove and plug the hoses connected to cooling fan motor.

NOTE: Observe hydraulic cleanliness requirements when opening hydraulic lines.

6. Remove the four M6 hex screws and nyloc nuts holding the fan motor mount channel to fan housing. Remove the fan assembly from the machine.
7. Remove the hex nut from the fan motor shaft in center of the fan blade.
8. Remove the fan blade from the motor shaft.

NOTE: A puller must be used to remove the fan blade from the tapered motor shaft.

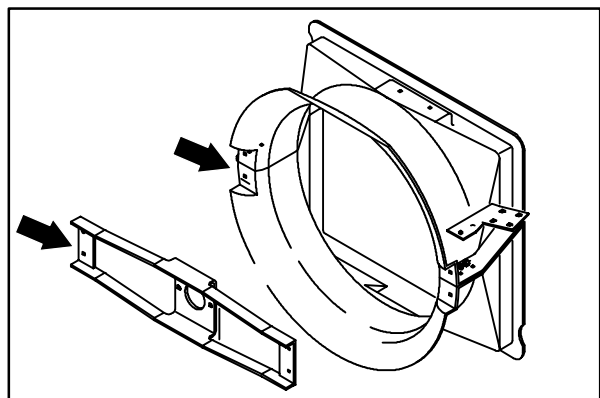
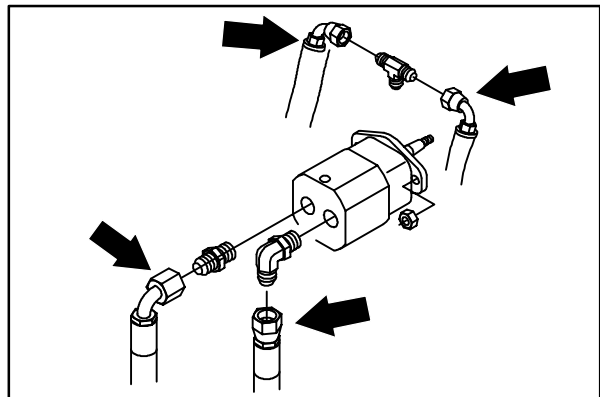
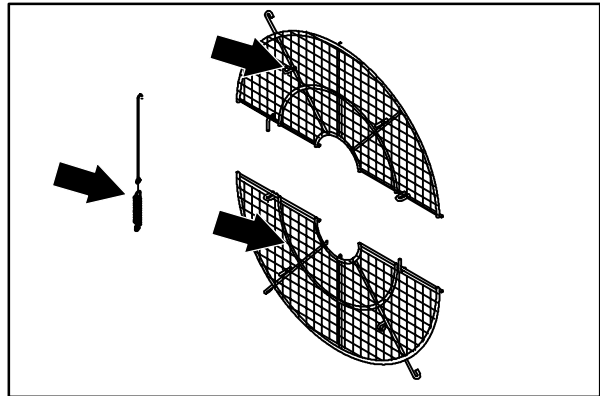
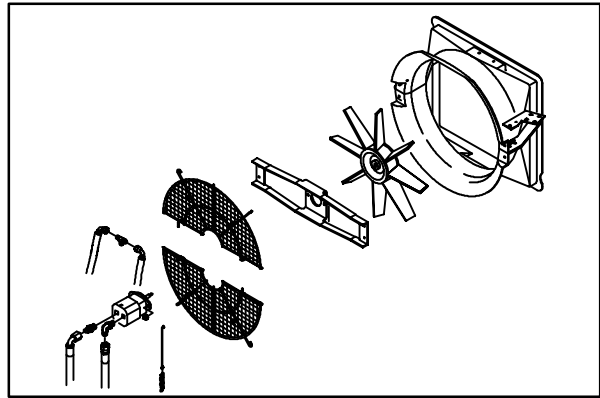

9. Remove the two M8 hex screws holding the fan motor to the mount channel.
10. Remove fittings from old fan motor and install in the new one.

NOTE: Remember to orientate the fittings as close as possible to the way they came out.

11. Reinstall the new motor on the mount channel using two M8 hex screws. Tighten to 18 - 24 Nm (13 - 18 ft lb).
12. Reinstall the fan blade back on the fan motor shaft.

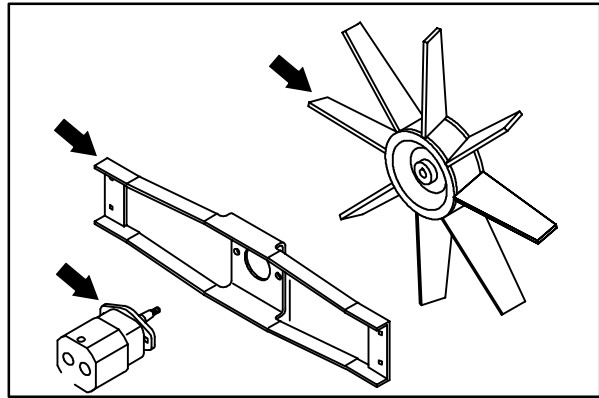

NOTE: Make sure the key is in place on the motor shaft.

13. Reinstall the hex nut on the fan motor shaft. Tighten to 18 - 24 Nm (13 - 18 ft lb).
14. Reinstall the fan motor assembly back on the fan housing. Use four M6 hex screws and nyloc nuts. Tighten to 8 - 10 Nm (5 - 7 ft lb).
15. Reconnect the hydraulic hoses to the fan motor. See schematic in this section.
16. Reinstall the screen guard. Reinstall the springs and hooks.
17. Reconnect the battery cables.
18. Start the machine and check the fan motor for any leaks and proper operation.

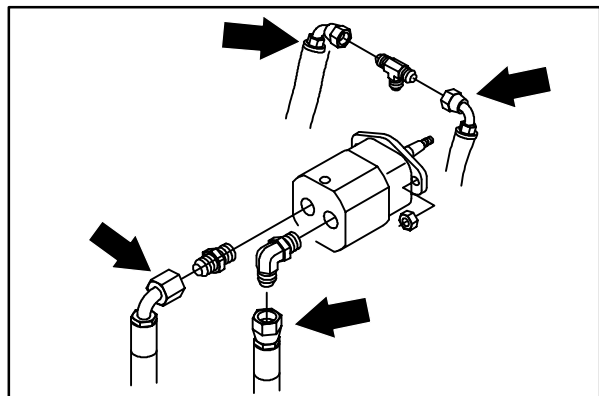
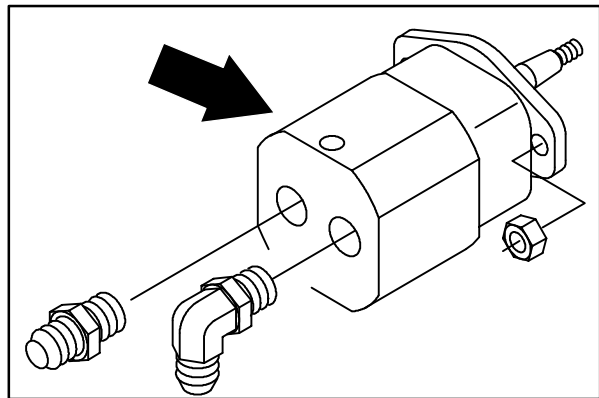

HYDRAULICS

TO REPLACE REAR DRIVE MOTOR

FOR SAFETY: Before Leaving Or Servicing Machine; Stop On Level Surface, Set Parking Brake, Turn Off Machine And Remove Key.

1. Engage the parking brake, block the front tires.

FOR SAFETY: Block machine tires before jacking machine up. Jack machine up at designated locations only. Block machine up with jack stands.

2. Jack up the rear of machine. Use jack stands to support the machine.
3. Remove the rear tire and wheel assembly.
4. Remove the cotter pin and slotted nut from the drive motor.
5. Remove the drive hub from the motor. A wheel puller may need to be used to break the hub free from the motor shaft.
6. Remove and plug the hydraulic hoses from the drive motor. Mark the hoses for proper assembly orientation.

NOTE: Observe hydraulic cleanliness requirements when opening hydraulic lines.

7. Remove the four hex screws holding the drive motor to the rear casting. Remove the drive motor.
8. Rebuild or replace the drive motor. If you replace the drive motor, remove the hydraulic fittings from the old motor and install in the new motor in the same orientation.
9. Position the new or rebuilt motor on the rear casting in the same orientation as it was removed.
10. Install the four socket-head screws and nyloc nuts. Torque nuts to 120 - 157 Nm (89 - 116 ft lb).

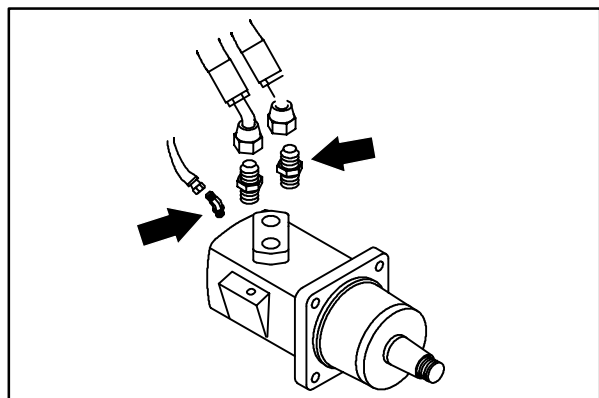
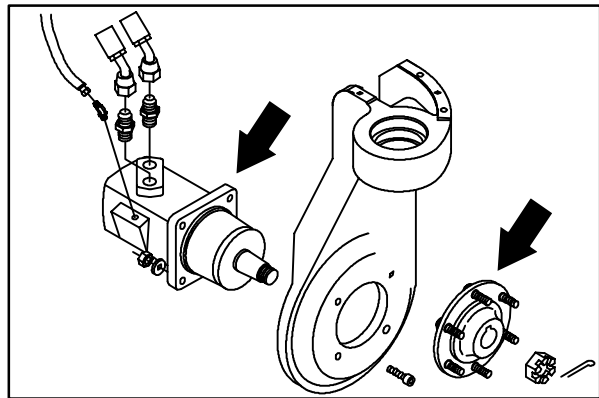
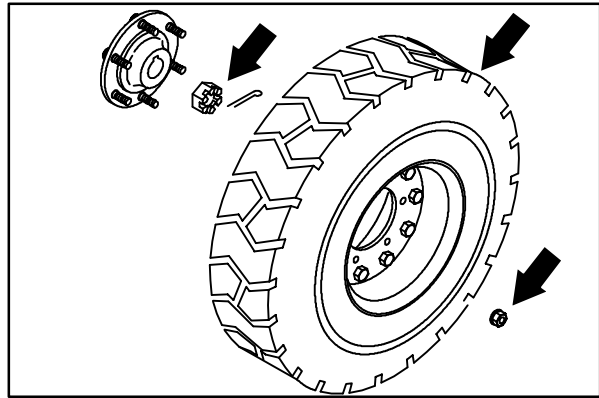

11. Reconnect the hydraulic hoses. Make sure each hose is placed on the fitting it was removed from.

NOTE: Observe hydraulic cleanliness requirements when opening hydraulic lines.

12. Place the drive hub on the tapered motor shaft. Tighten slotted nut to 270 - 340 Nm (200 - 250 ft lb). Install cotter pin.

NOTE: Make sure the square key is in place on the motor shaft before installing the drive hub.

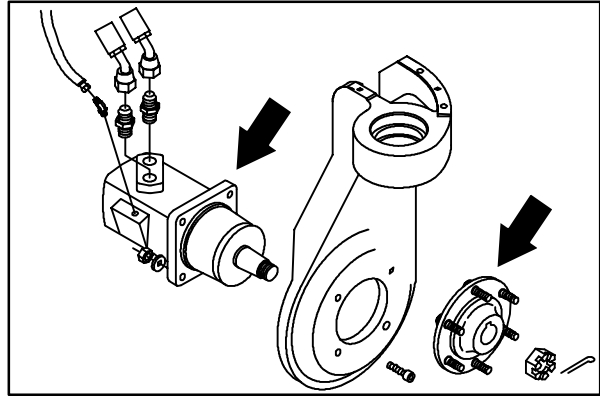

13. Install the rear tire and wheel assembly. Tighten the six wheel nuts to 122 - 142 Nm (90 - 105 ft lb).
14. Start the machine and run the propel circuit in forward and reverse. Check for leaks and proper operation.
15. Remove jack stands and lower machine.

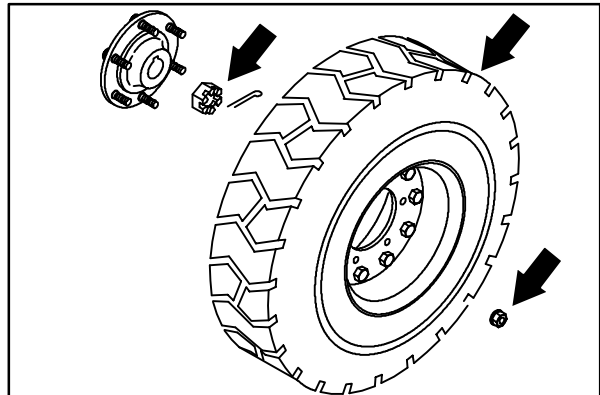

HYDRAULICS

TO REPLACE MAIN BRUSH MOTOR

FOR SAFETY: Before Leaving Or Servicing Machine; Stop On Level Surface, Set Parking Brake, Turn Off Machine And Remove Key.

1. Raise the hopper and engage the hopper prop arm.

⚠ WARNING: Raised Hopper May Fall. Engage Hopper Support Bar.

2. Remove the main brush from the machine. See TO REPLACE MAIN BRUSH instructions in this section.
3. Remove and plug the hydraulic hoses from the brush motor.

Note: Observe hydraulic cleanliness requirements when opening hydraulic lines.

4. Remove the cotter pin from the castle nut at the end of brush drive plug.
5. Hold the brush drive plug and remove the castle nut.
6. A puller must be used to remove the brush drive plug from the tapered shaft on the brush motor.
7. Remove four 0.375 in. hex screws from main brush motor arm. Brush motor can now be removed. (Note orientation of motor in brush arm).
8. Remove hydraulic fittings from old motor.
9. Install new or rebuilt main brush motor back in main brush arm. Tighten 0.375 in. hex screws to 37 – 47 Nm (27 – 35 ft lb). Make sure corners of brush motor line up with slots in brush arm.
10. Reinstall hydraulic fittings in motor.
11. Reconnect hydraulic hoses to motor. (See schematic in hydraulic section).

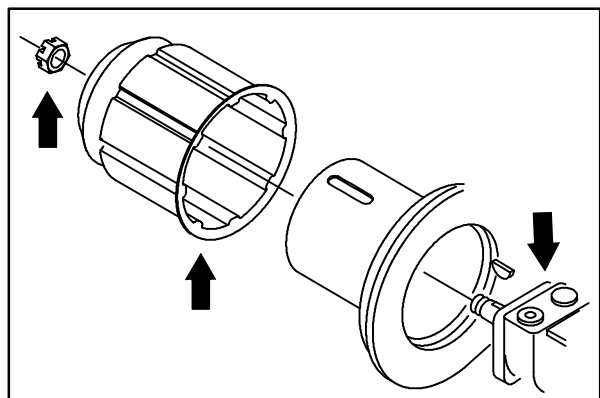
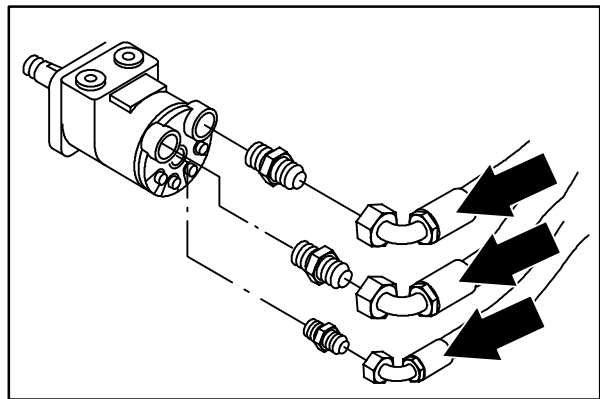
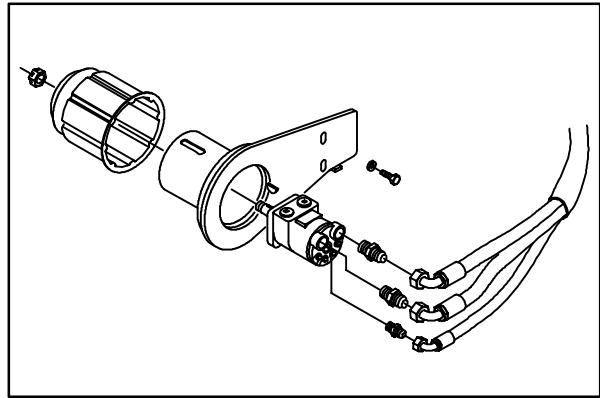

12. Reinstall brush drive plug on tapered motor shaft. (Make sure key is in place).
13. Reinstall castle nut and tighten to 40 - 54 Nm (30 - 40 ft lb). Continue to tighten castle nut until it lines up with hole in brush motor shaft. Install new cotter pin.
14. Reinstall main brush.
15. Lower the hopper, operate the main brush and check for proper rotation and leaks.

HYDRAULICS

TO REPLACE SIDE BRUSH MOTOR

1. Remove the side brush. See TO REPLACE SIDE BRUSH instructions in the SWEEPING section.

FOR SAFETY: Before Leaving Or Servicing Machine; Stop On Level Surface, Set Parking Brake, Turn Off Machine And Remove Key.

2. Remove and plug the hydraulic hoses from the side brush motor.

NOTE: Observe hydraulic cleanliness requirements when opening hydraulic lines.

3. Remove the four 0.375 in. hex screws from the bottom of the side brush motor. Remove the side brush guard and the side brush motor from the machine.
4. Remove the hydraulic fittings from the the old motor.
5. Install new or rebuilt side brush motor and side brush guard with .375 in. hex screws tighten to 37 - 47 Nm (27 - 35 ft lb). Make sure to install four 0.375 SAE flat washers between motor and mount bracket.
6. Reinstall hydraulic fittings in motor.
7. Reconnect hydraulic hoses to motor. (See schematic in HYDRAULICS section.)
8. Slide the side brush onto the side brush drive shaft.
9. Insert the side brush clevis pin through the side brush hub and shaft. Reinstall the hair pin and cable back into the hole in the end of the clevis pin.

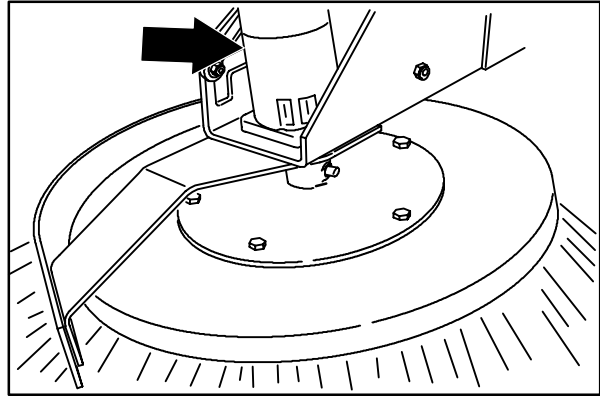

08466

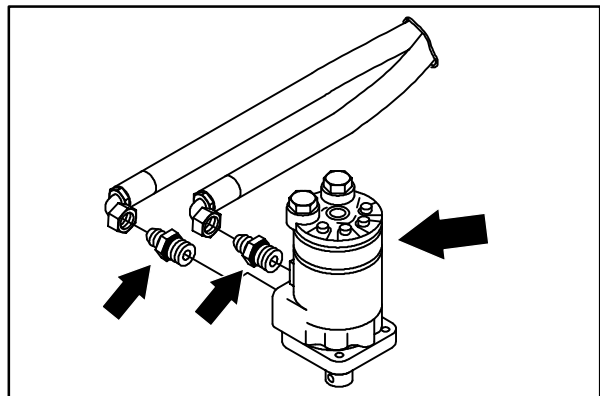
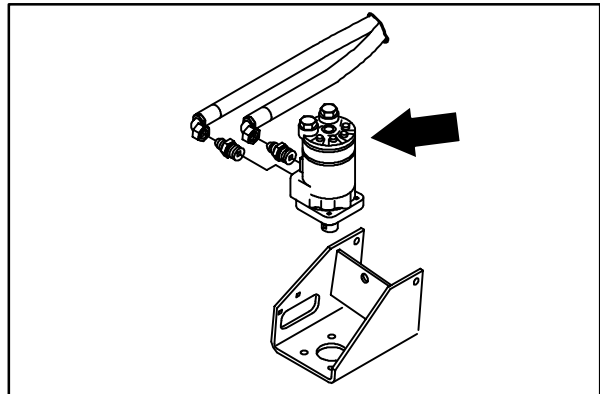

TO REPLACE POWER THROW™ BRUSH MOTOR

FOR SAFETY: Before Leaving Or Servicing Machine; Stop On Level Surface, Set Parking Brake, Turn Off Machine And Remove Key.

1. Set the machine parking brake and remove the Power Throw™ brush and idler plate. See TO REPLACE POWER THROW™ BRUSH instructions in the SWEEPING section.

⚠ WARNING: Raised Hopper May Fall. Engage Hopper Support Bar.

2. Go into the main brush area and locate the Power Throw™ brush drive plug.
3. Remove the M6 hex screw on the end of the plastic drive plug. Pull the drive plug off the shaft. Retain the square key.
4. Remove and plug the two hydraulic hoses on the brush motor.

NOTE: Observe hydraulic cleanliness requirements when opening hydraulic lines.

5. Remove the four 0.375 in. socket head screws holding hydraulic motor to arm.
6. Remove the hydraulic motor and drive shaft from the brush arm. Note the orientation of the motor in the brush arm.
7. Drive the roll pin out of the shaft. Remove the drive shaft from the motor.
8. Install the drive shaft and roll pin on new or rebuilt hydraulic motor.
9. Remove the hydraulic fittings from the old motor and reinstall in the new motor.
10. Reinstall new motor and drive shaft on brush arm using four 0.375 in. socket head screws. Tighten to 37 - 40 Nm (27 - 30 ft lb). Note the orientation of the motor in the brush arm.

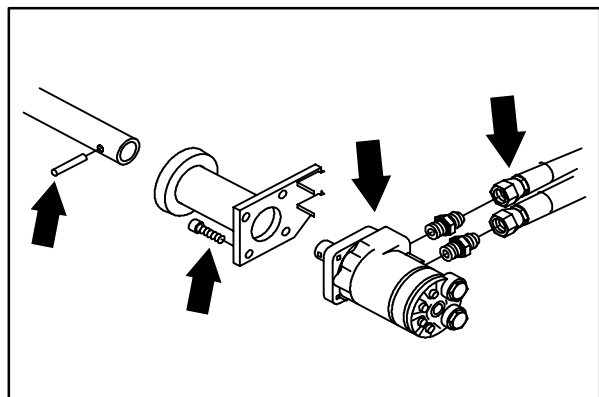
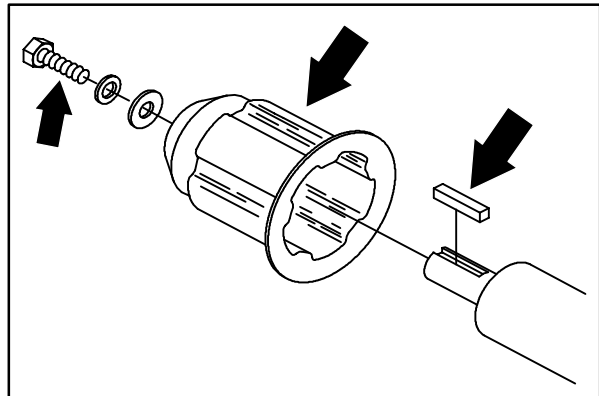
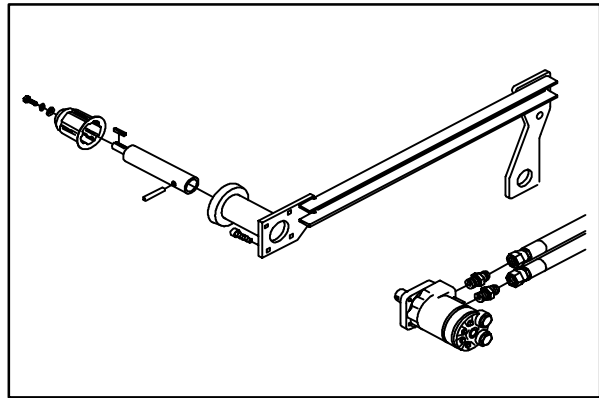
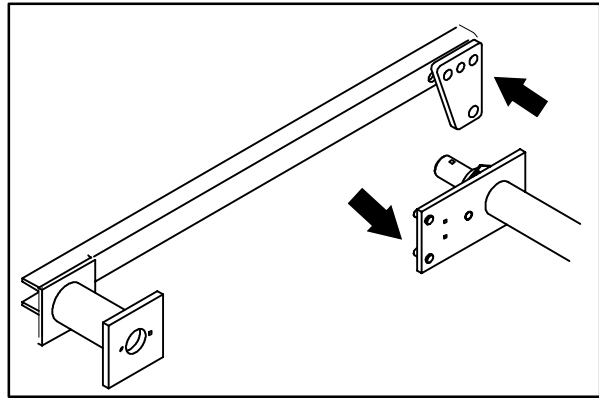

HYDRAULICS

11. Reconnect the two hydraulic hoses to motor. (See schematic in HYDRAULICS section.)
12. Reinstall brush drive plug. Tighten M6 hex screw to 7 - 10 Nm (5 - 8 ft lb). Make sure the square key is in place in the drive shaft.
13. Reinstall the Power Throw™ brush and idler plate. See TO REPLACE POWER THROW™ BRUSH instructions in the SWEEPING section.

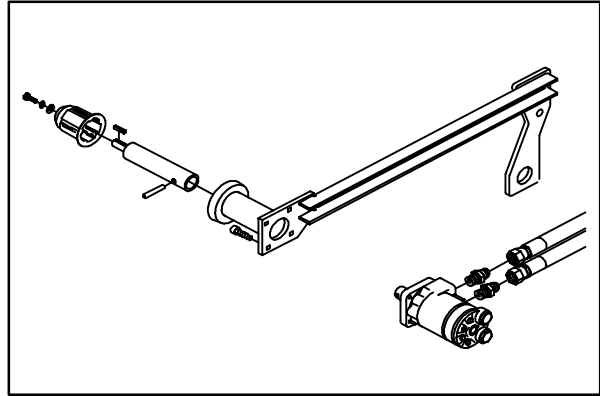

VACUUM FAN

The vacuum fan is hydraulically driven. It pulls air from the main brush area and through the hopper filters. There is no vacuum when the hopper is in the raised position.

TO REPLACE VACUUM FAN HYDRAULIC MOTOR

FOR SAFETY: Before Leaving Or Servicing Machine; Stop On Level Surface, Set Parking Brake, Turn Off Machine And Remove Key.

1. Dump the machine debris hopper.
2. Set the machine parking brake.
3. Raise the hopper, engage the hopper prop arm, and lower the hopper.

⚠ WARNING: Raised Hopper May Fall. Engage Hopper Support Bar.

4. Shut off the engine.
5. Open the engine cover and side door.

NOTE: The vacuum fan must be removed from the machine to replace the hydraulic motor.

6. Remove the vacuum hose and bracket from the front of vacuum fan housing.
7. Disconnect the wires leading to the Thermo Sentry™
8. Disconnect and plug the three hydraulic hoses at the vacuum fan motor.

NOTE: Observe hydraulic cleanliness requirements when opening hydraulic lines.

9. Remove the two M10 hex screws, washers, and rubber isolators holding the vacuum fan housing to the machine frame.

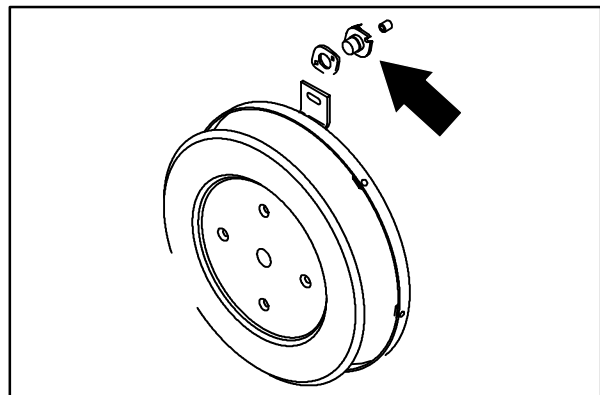
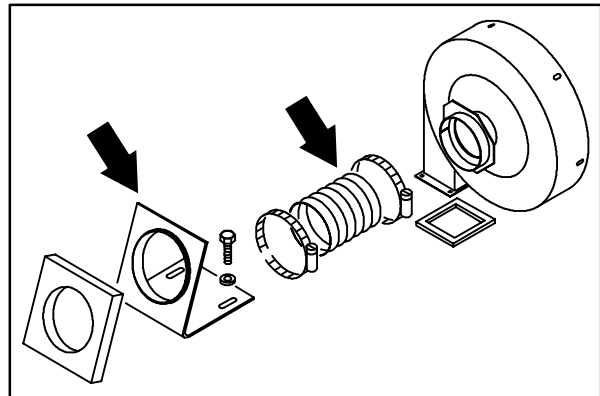
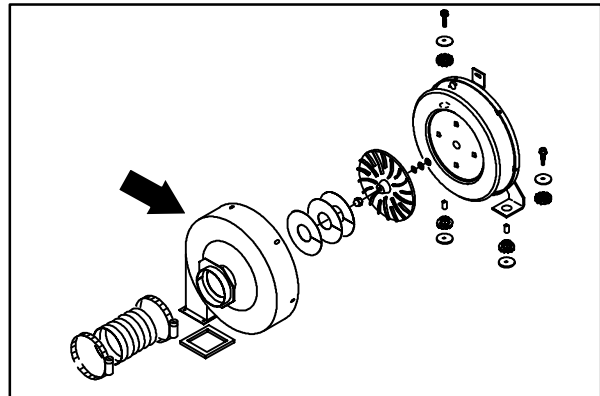
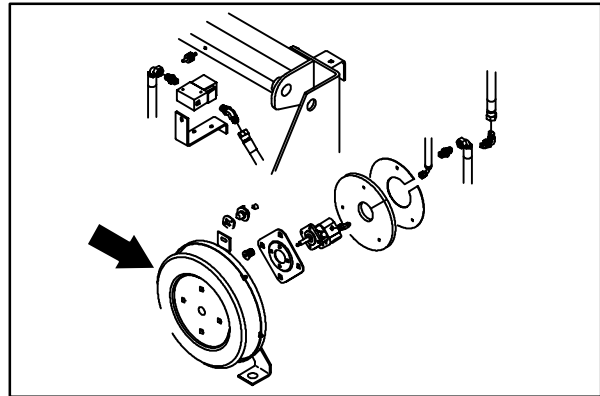

HYDRAULICS

10. Remove solenoid valve mounting bracket and rubber isolator from top of vacuum fan housing.
11. Tip the vacuum fan assembly forward and remove it from the machine.
12. Remove the six 0.31 in. hex screws holding the front housing to rear housing.

NOTE: Mark the orientation of the outer fan housing to the inner housing for proper re-assembly.

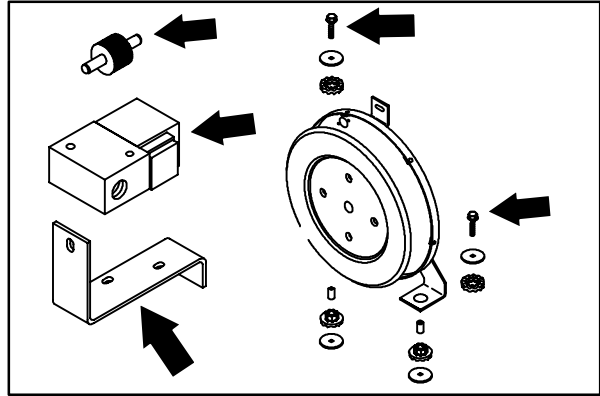

13. Remove the crown nut from the impeller shaft. Slide the impeller off the shaft. (Remove and save key and any shims on shaft under impeller.)
14. Turn the housing over and remove the four 0.375 in. nyloc nuts and washers from the motor mount plate. Remove the plate from housing.

NOTE: Mark the orientation of the motor and fittings before removal.

15. Remove the four 0.25 in. flat head screws and nyloc nuts holding the motor to the plate.
16. Install the new motor to the plate. Tighten the four 0.25 in. flat head screws to 9 - 13 Nm (7 - 10 ft lb).
17. Remove the three hydraulic fittings from the old motor. Install in the new motor.

NOTE: Make sure the fittings are positioned in the same orientation as they were removed.

NOTE: Make sure the motor and fittings are positioned in the same orientation as they were removed.

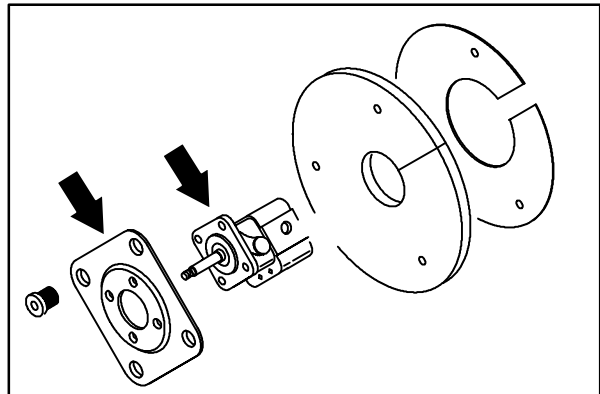
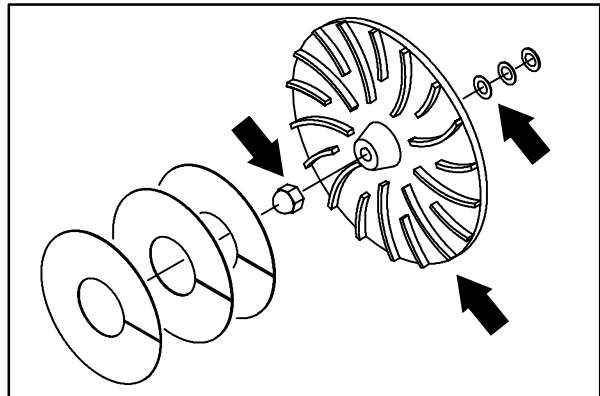
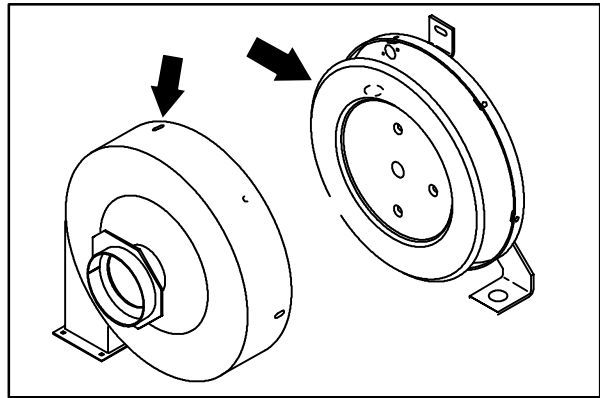

- Turn the housing over and reinstall the shims, key, fan impeller, and crown nut. Tighten the crown nut to 34 - 47 Nm (25 - 35 ft lb).

NOTE: Use blue loctite 242 on shaft threads.

NOTE: Be sure key is in shaft. Super gluing key helps keep key in place.

NOTE: Make sure the impeller spins freely before continuing with the assembly.

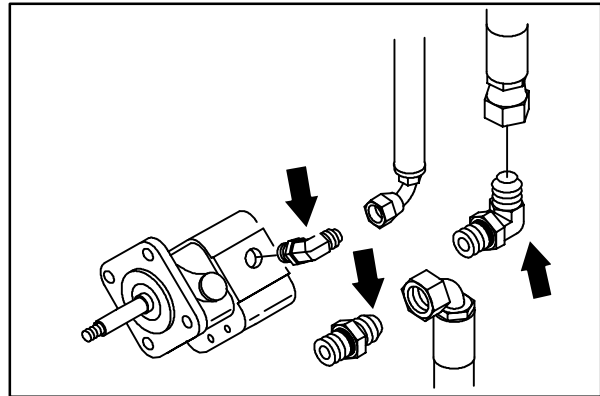

- Reinstall the front housing on the rear housing. Reinstall 0.31 in. hex screws and tighten to 22 - 27 Nm (16 - 20 ft lb).

NOTE: Tennant part no. 57543 plastic shims must be used for proper fan to housing clearance. Remove the shims through the fan intake after tightening screws.

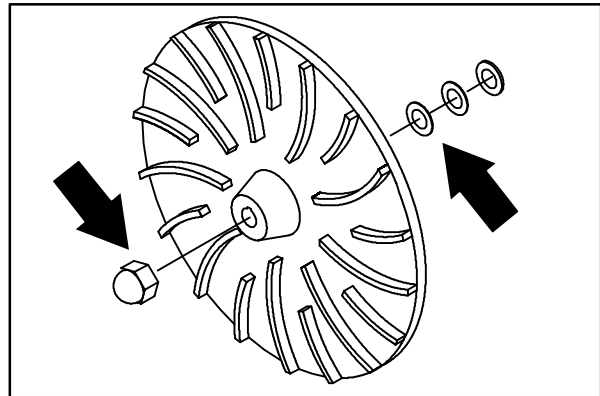

- Reinstall the vacuum fan assembly into the machine. Tighten the M10 hex screws to 37 - 48 Nm (26 - 34 ft lb).

- Reinstall the solenoid mount bracket and isolator to the top of fan assembly.

- Reconnect the hydraulic hoses to the vacuum fan motor. See schematic in HYDRAULICS section.

- Reinstall the vacuum hose and mounting bracket to the front of vacuum fan. Tighten the two M8 hex screws to 18 - 24 Nm (13 - 18 ft lb).

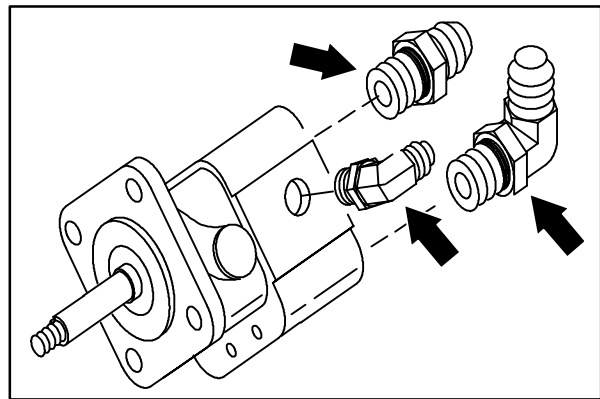

- Reconnect the electrical harness to the thermo sentry™. See schematic in HYDRAULICS section.

- Start the machine and operate the vacuum fan. Check for leaks and proper operation.

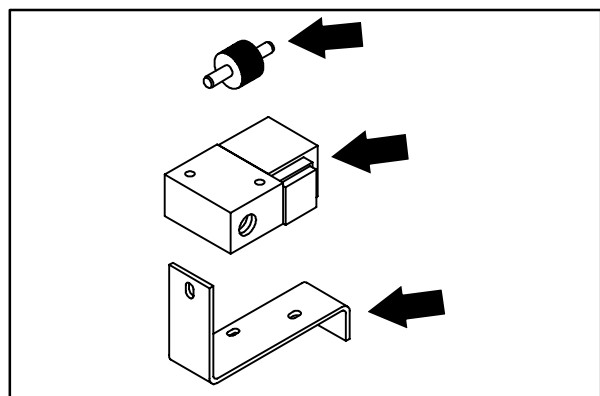

**Fig. 1 - Hydraulic Schematic 800 G/LPG/D
(for machines below serial number 2300)**

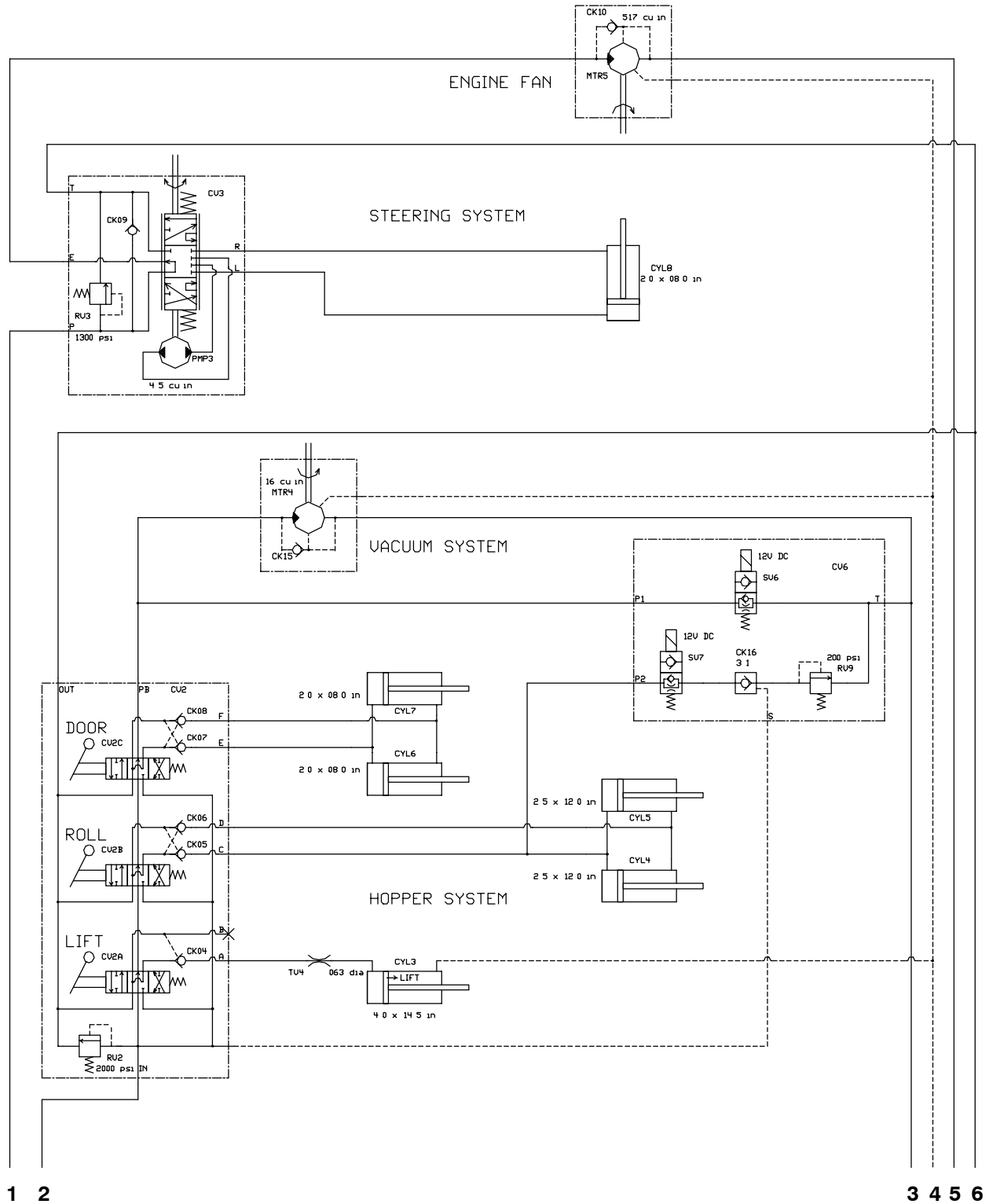
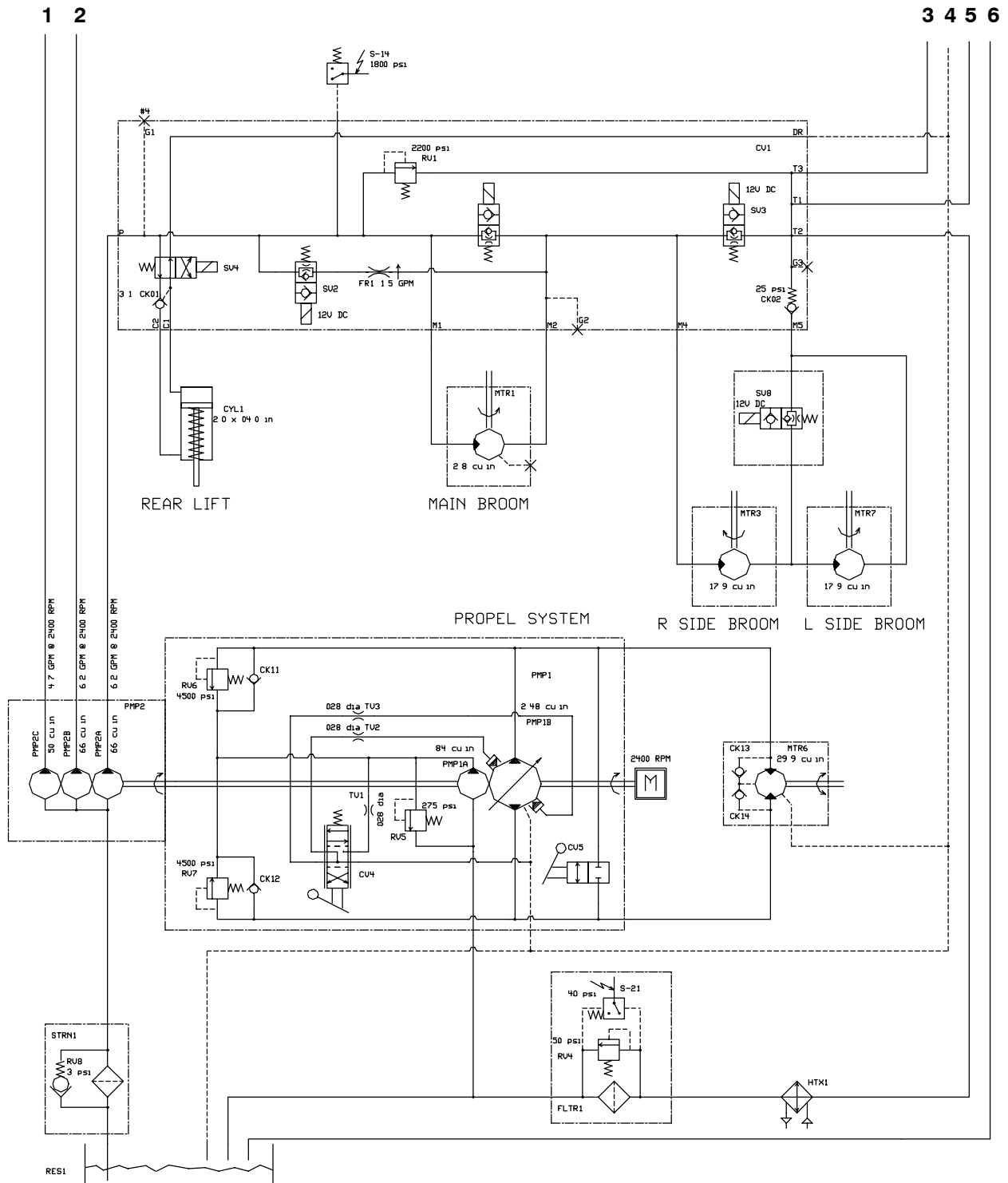
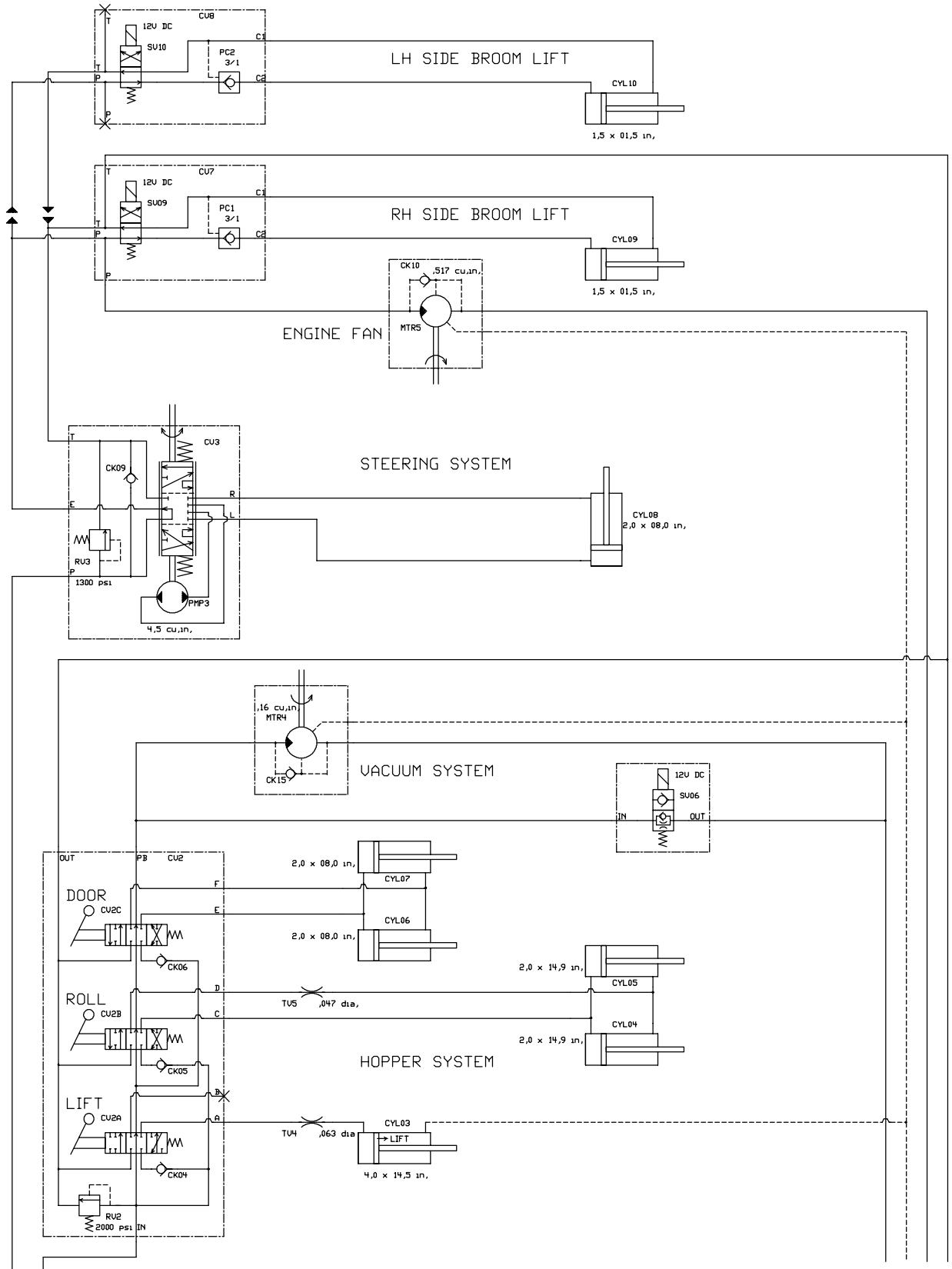

Fig. 1 – Hydraulic Schematic 800 G/LPG/D
(for machines below serial number 2300)



HYDRAULICS

**Fig. 2 - Hydraulic Schematic 800 G/LPG/D
(for machines serial number 2300 and above)**



1 2

3 4 5 6

Fig. 2 - Hydraulic Schematic 800 G/LPG/D
(for machines serial number 2300 and above)

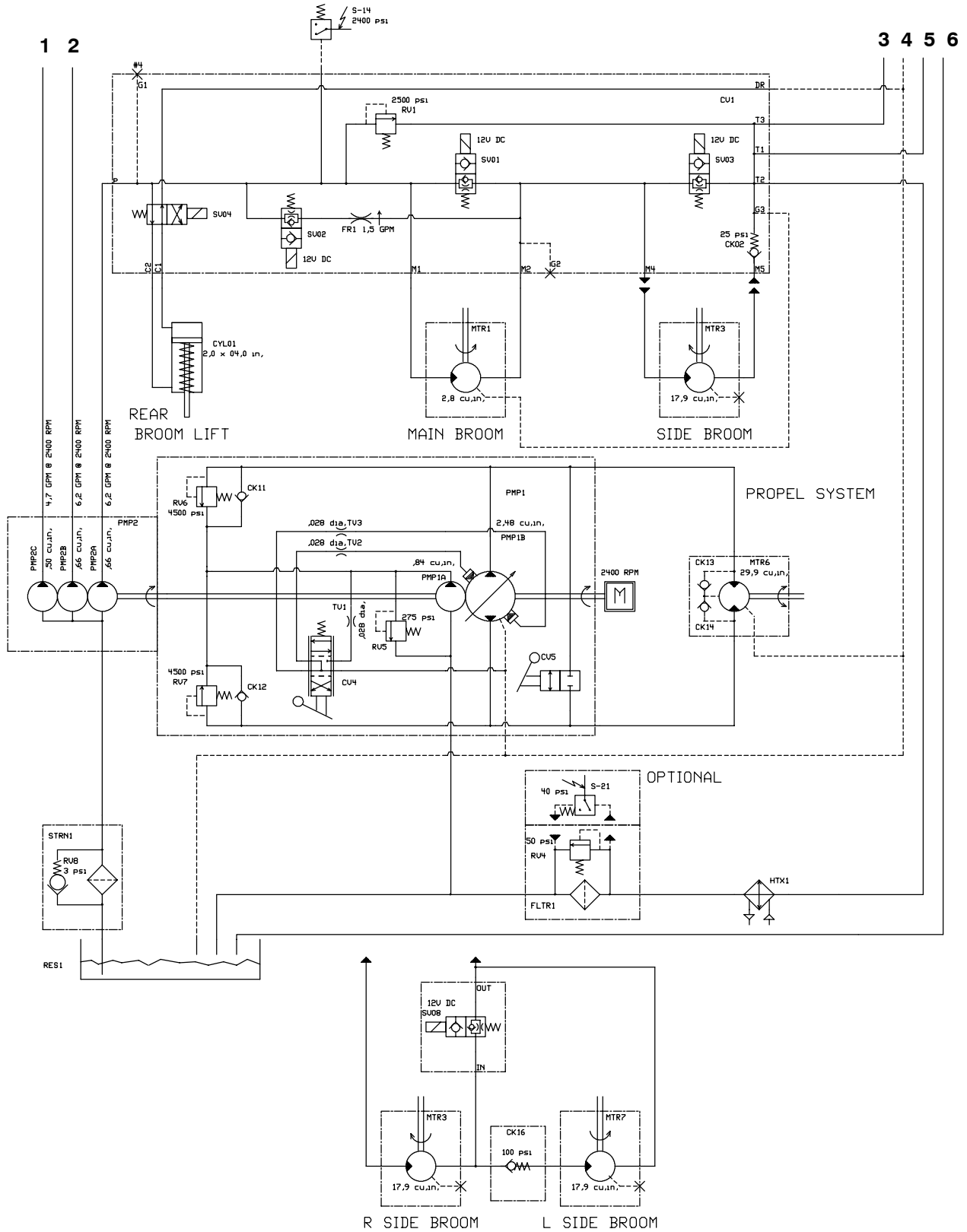

**Fig. 3 - Hydraulic Schematic 810 G/LPG/D
(for machines below serial number 2300)**

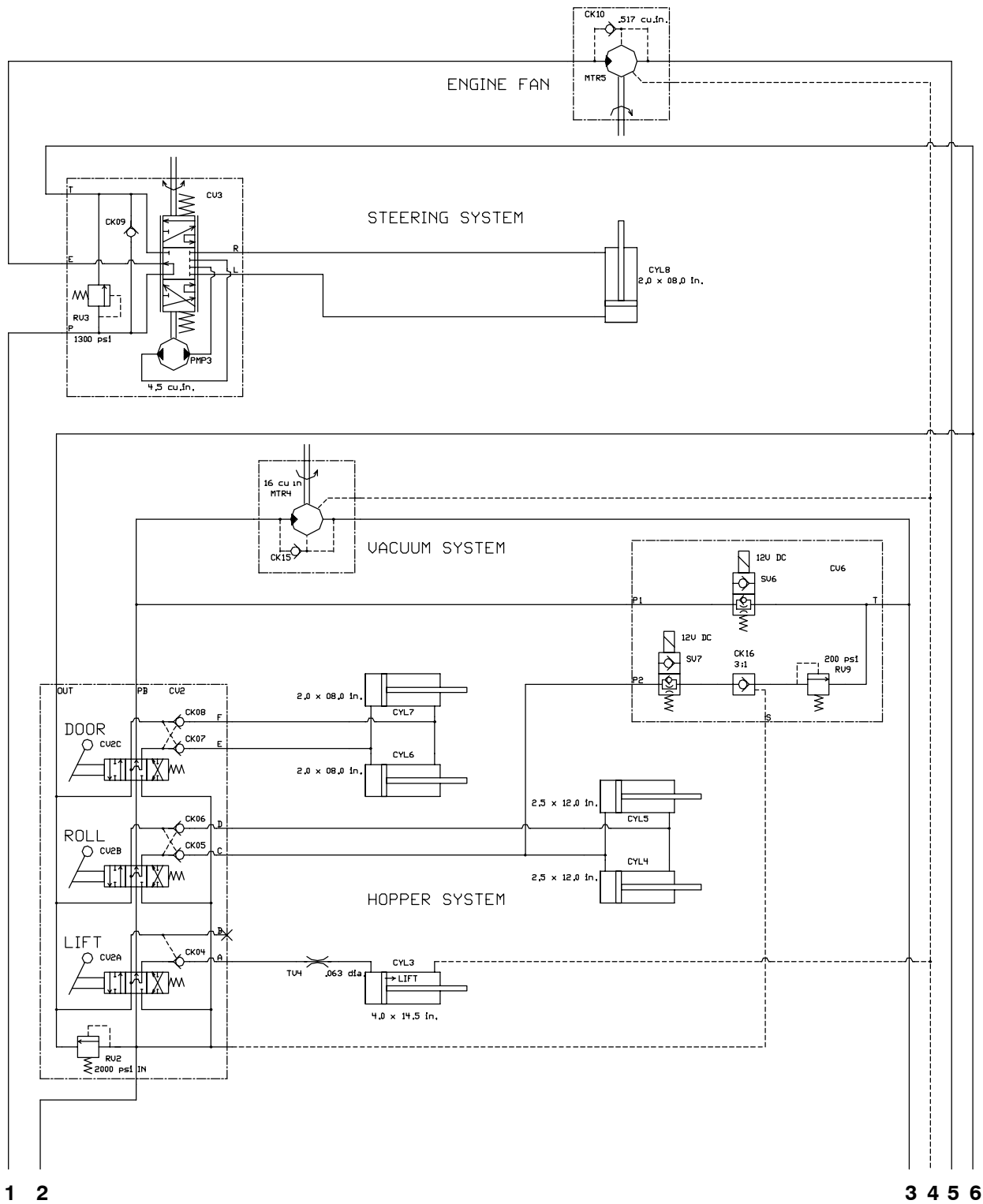
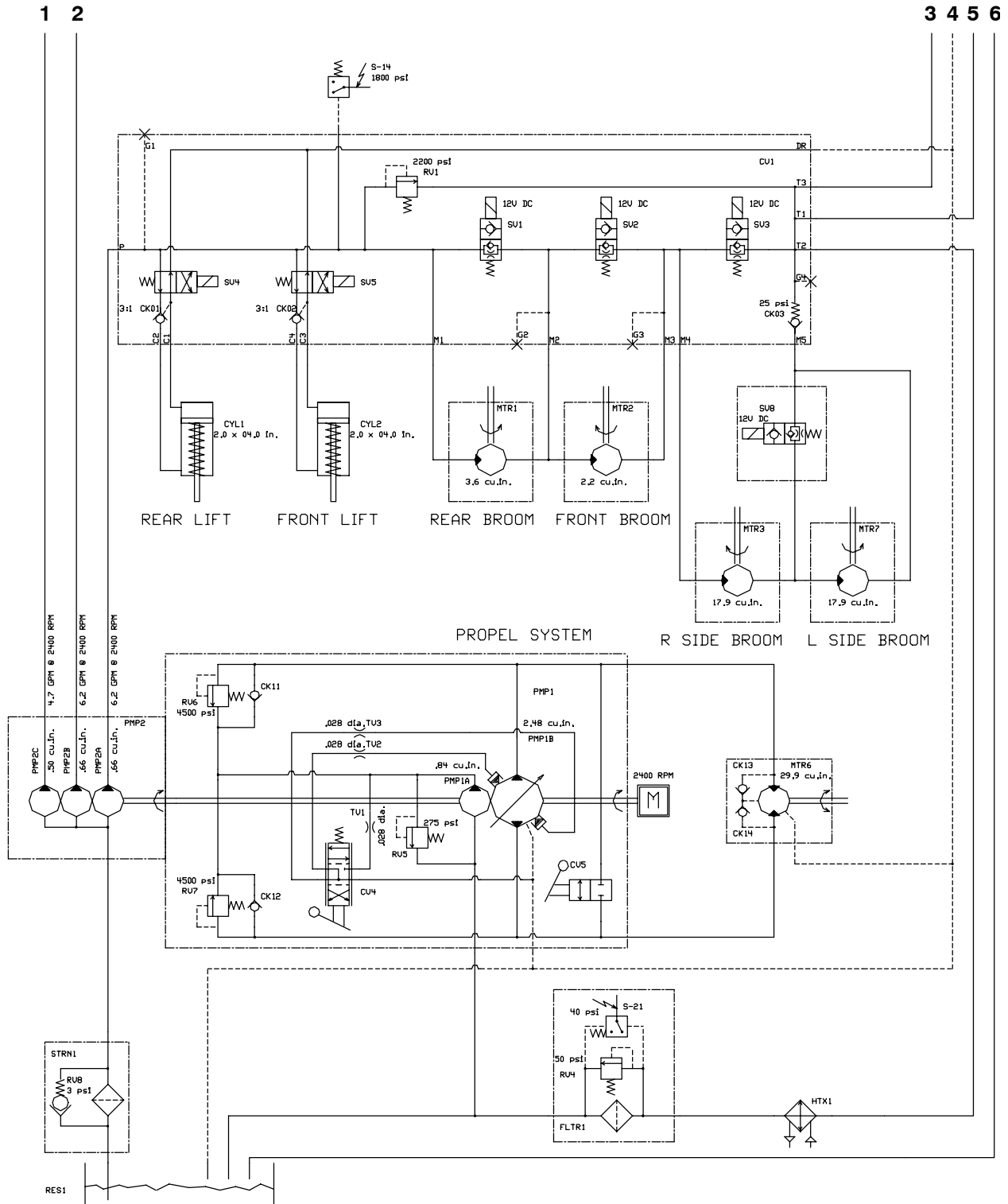
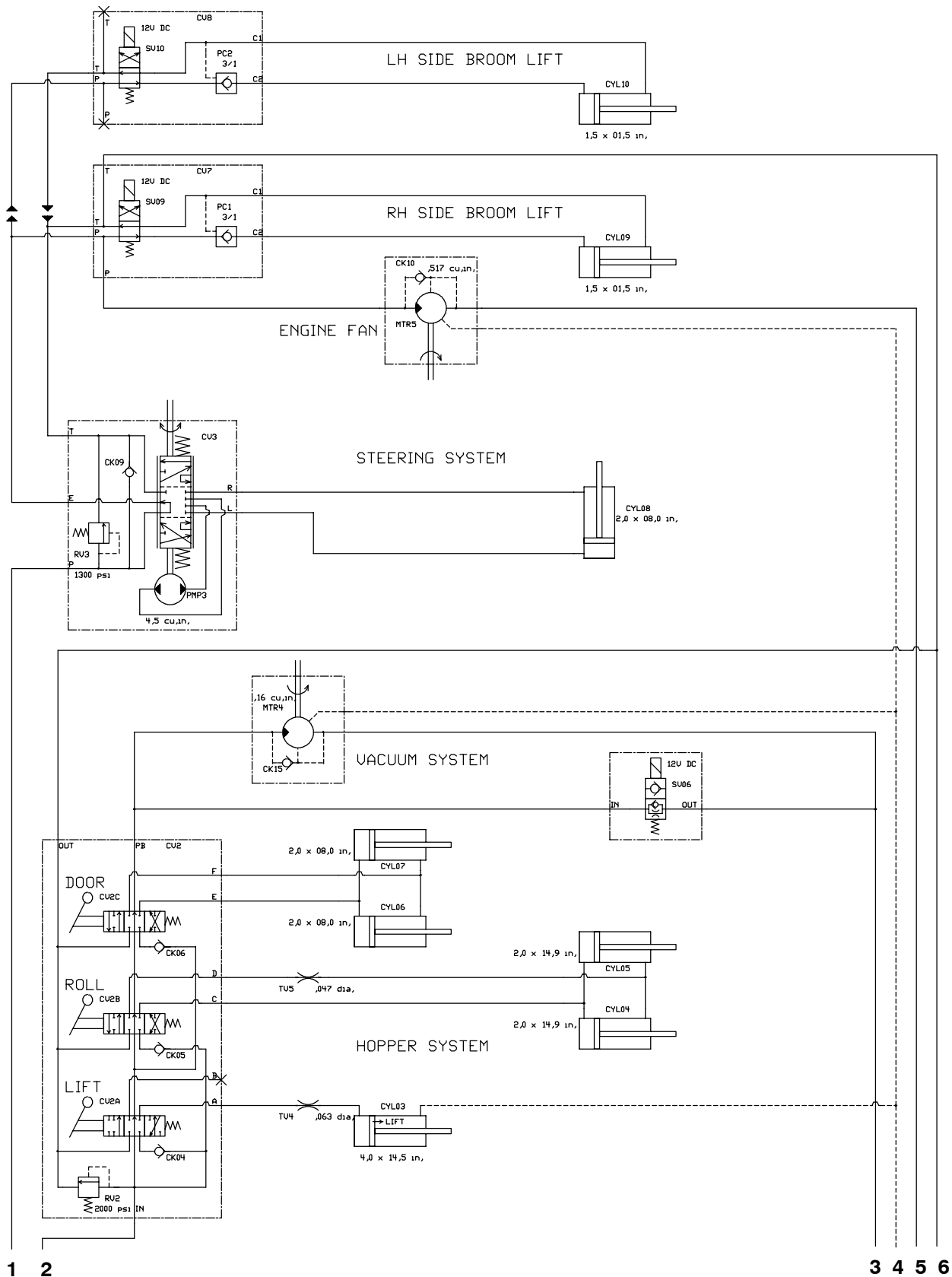

Fig. 3 – Hydraulic Schematic 810 G/LPG/D
(for machines below serial number 2300)



**Fig. 4 - Hydraulic Schematic 810 G/LPG/D
(for machines serial number 2300 and above)**



**Fig. 4 - Hydraulic Schematic 810 G/LPG/D
(for machines serial number 2300 and above)**

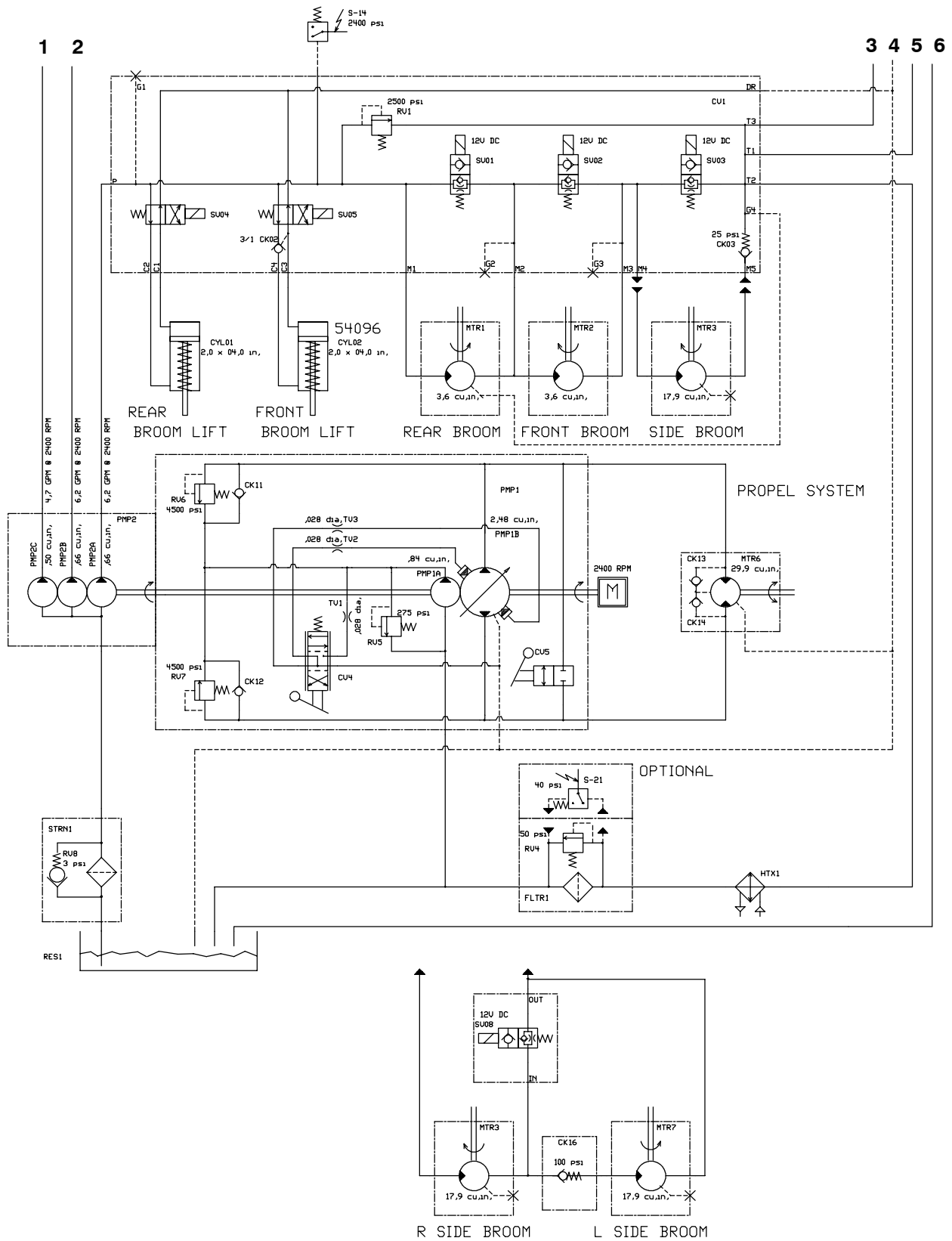

**Fig. 5 - Hydraulic Hose Group 800 G/LPG/D
(for machines below serial number 2300)**

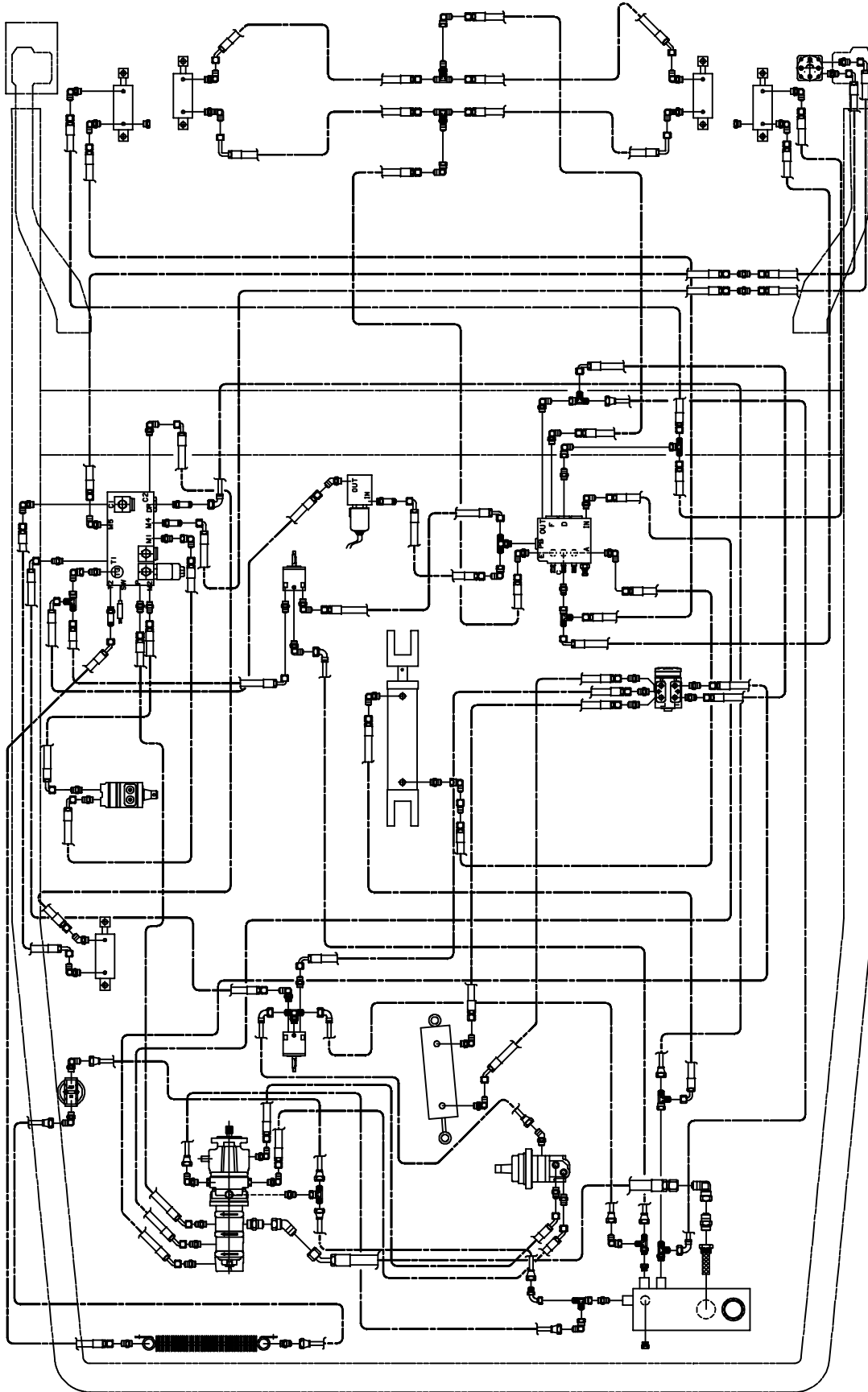
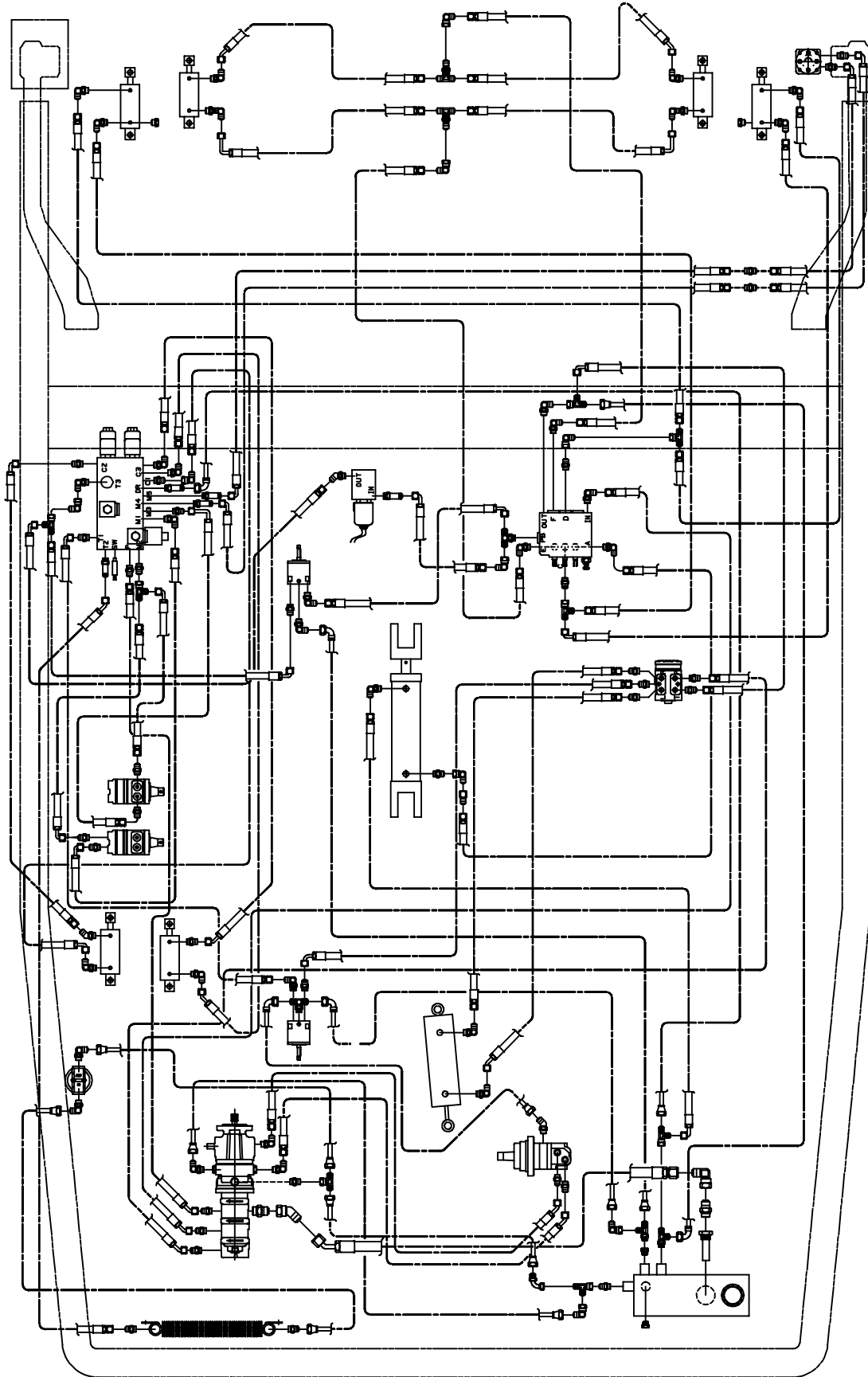

Fig. 6 - Hydraulic Hose Group 810 G/LPG/D
(for machines below serial number 2300)



TROUBLESHOOTING

The troubleshooting charts that follow are organized so they lead you through the circuits. They include flow charts and instructions for you as to where to insert your test instruments.

HYDRAULICS

800 MAIN - LO SPD AND VAC FAN

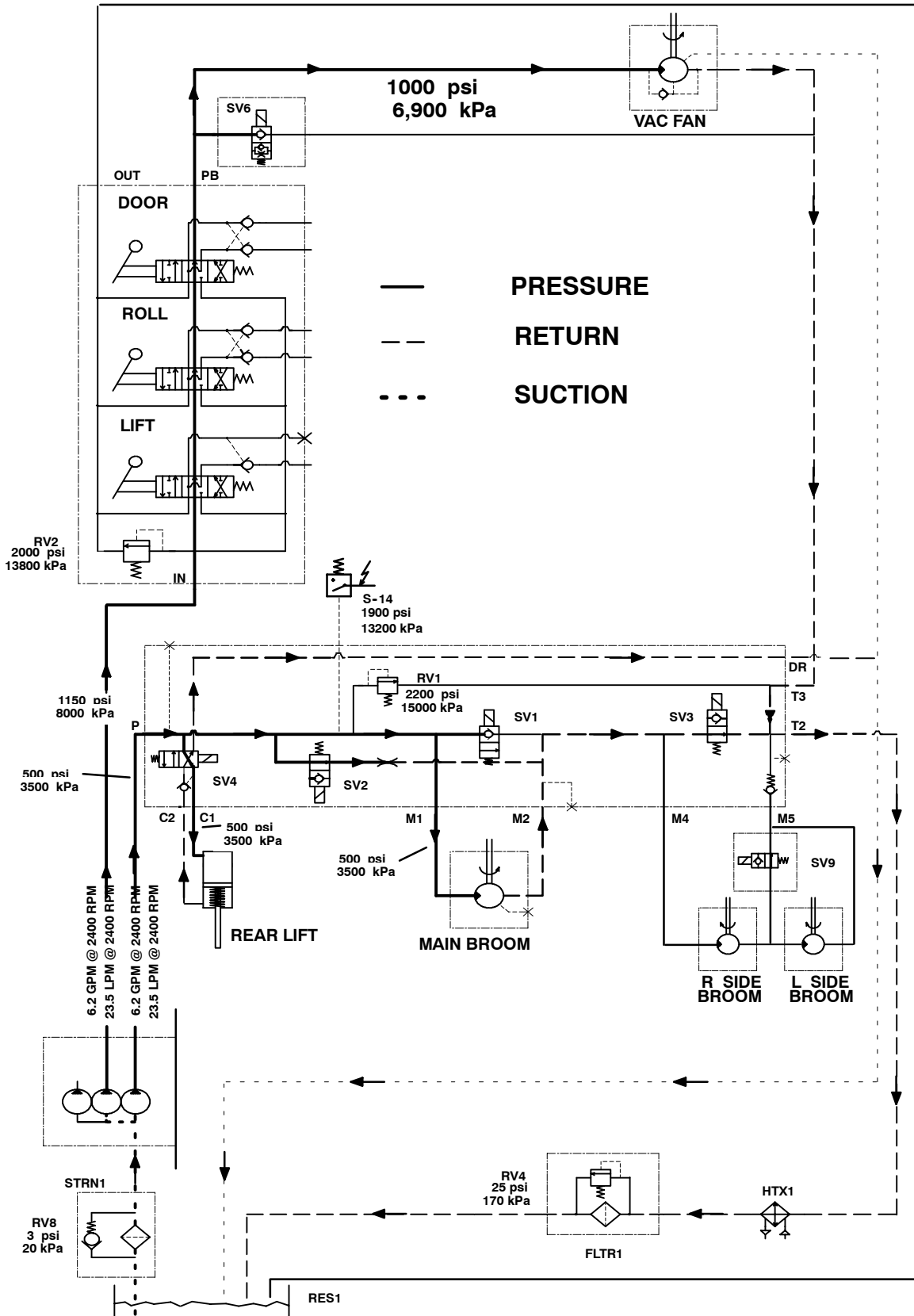

810 REAR BROOM AND VAC FAN

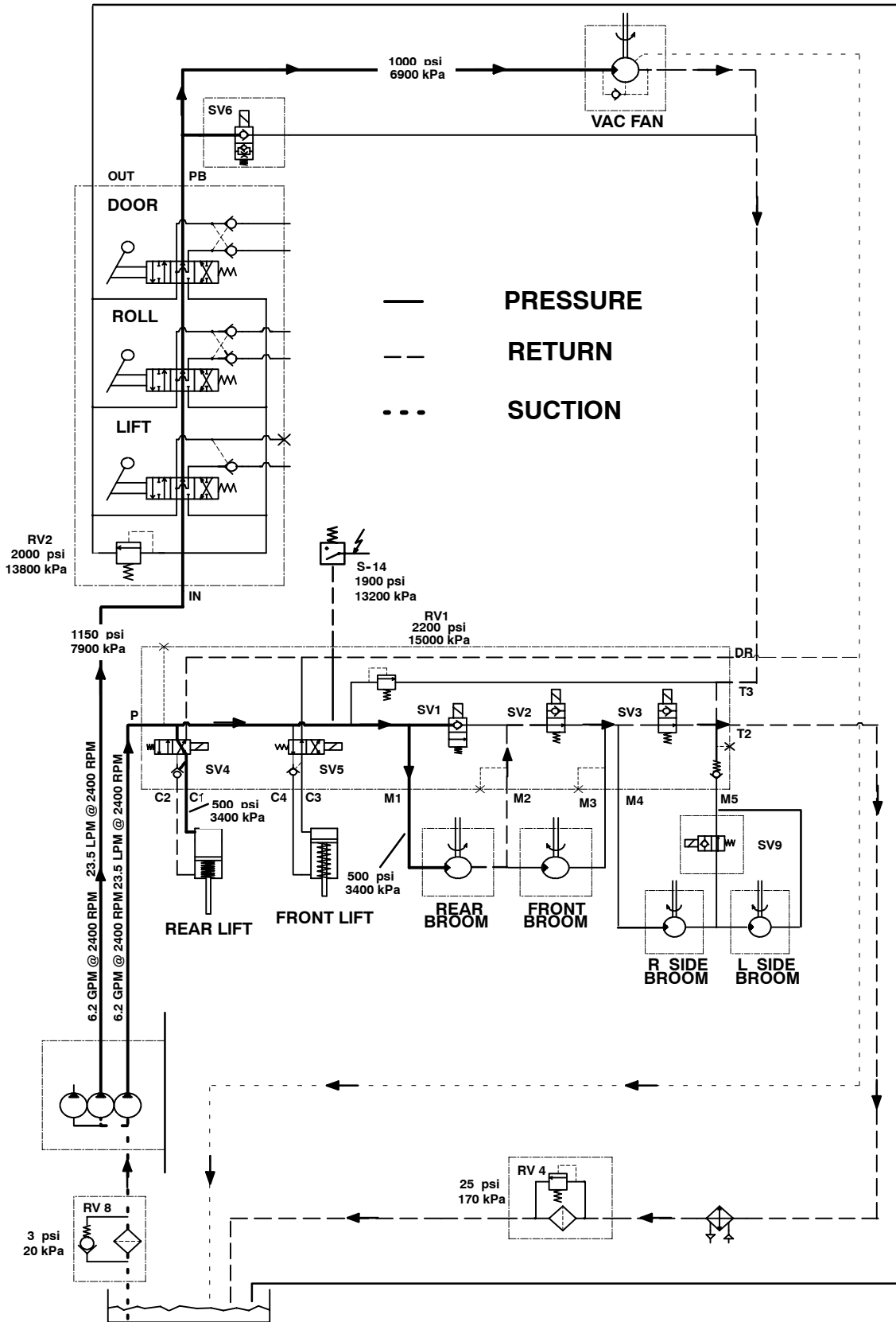

HYDRAULICS

800 MAIN, S. BR. AND VAC FAN

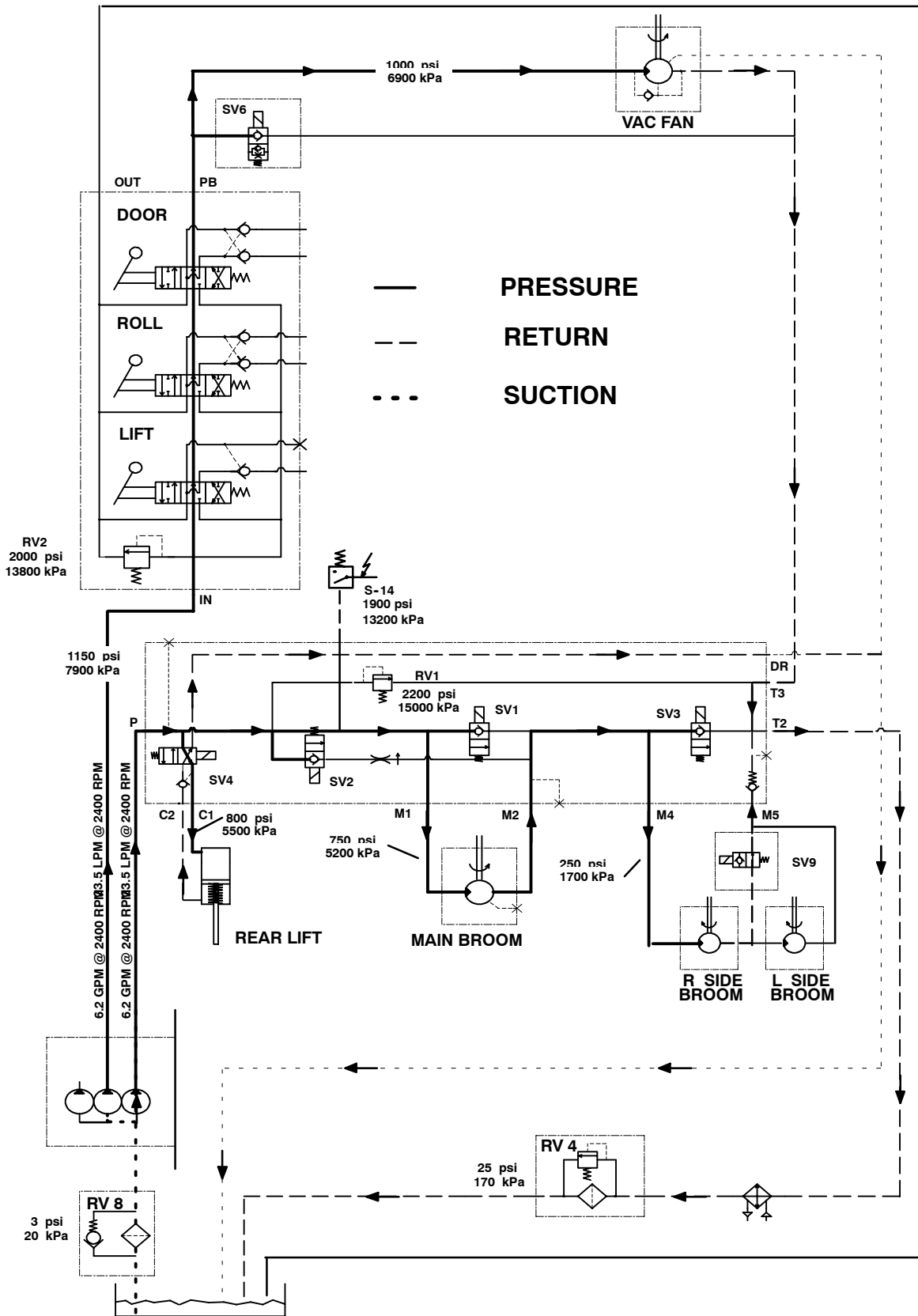

810 ALL BROOMS AND VAC FAN

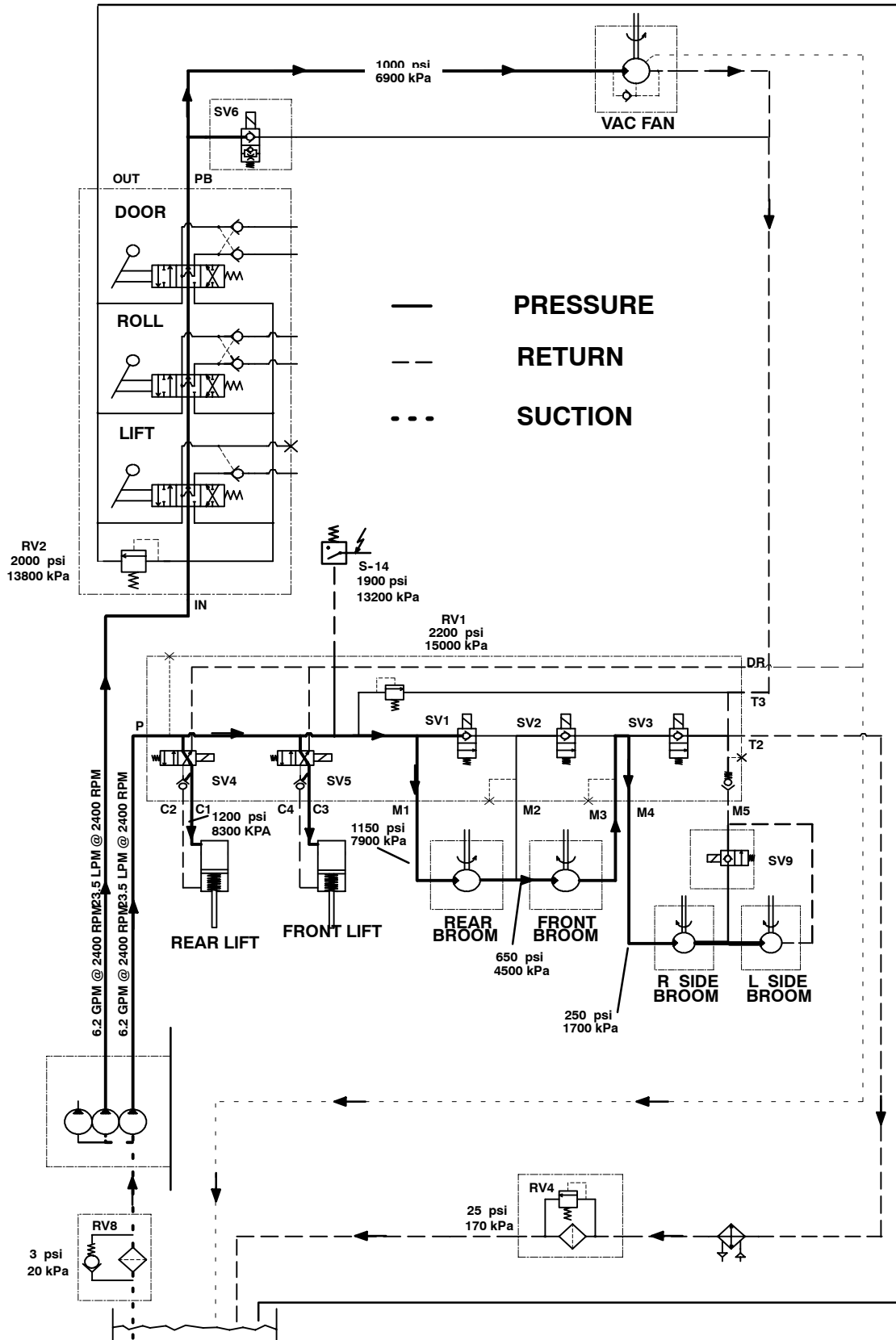

800 / 810 HOPPER LOWER

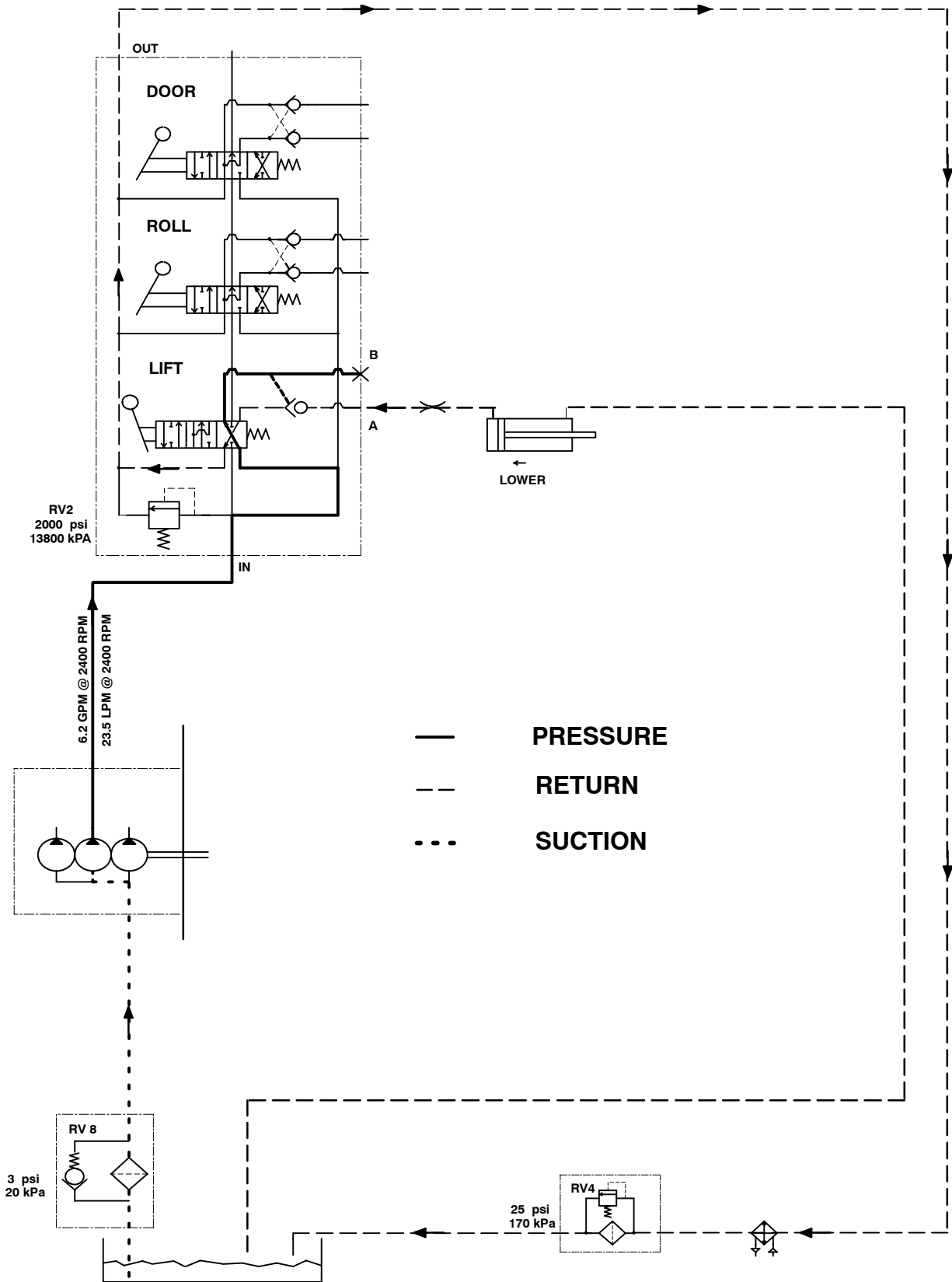

800 / 810 HOPPER LIFT

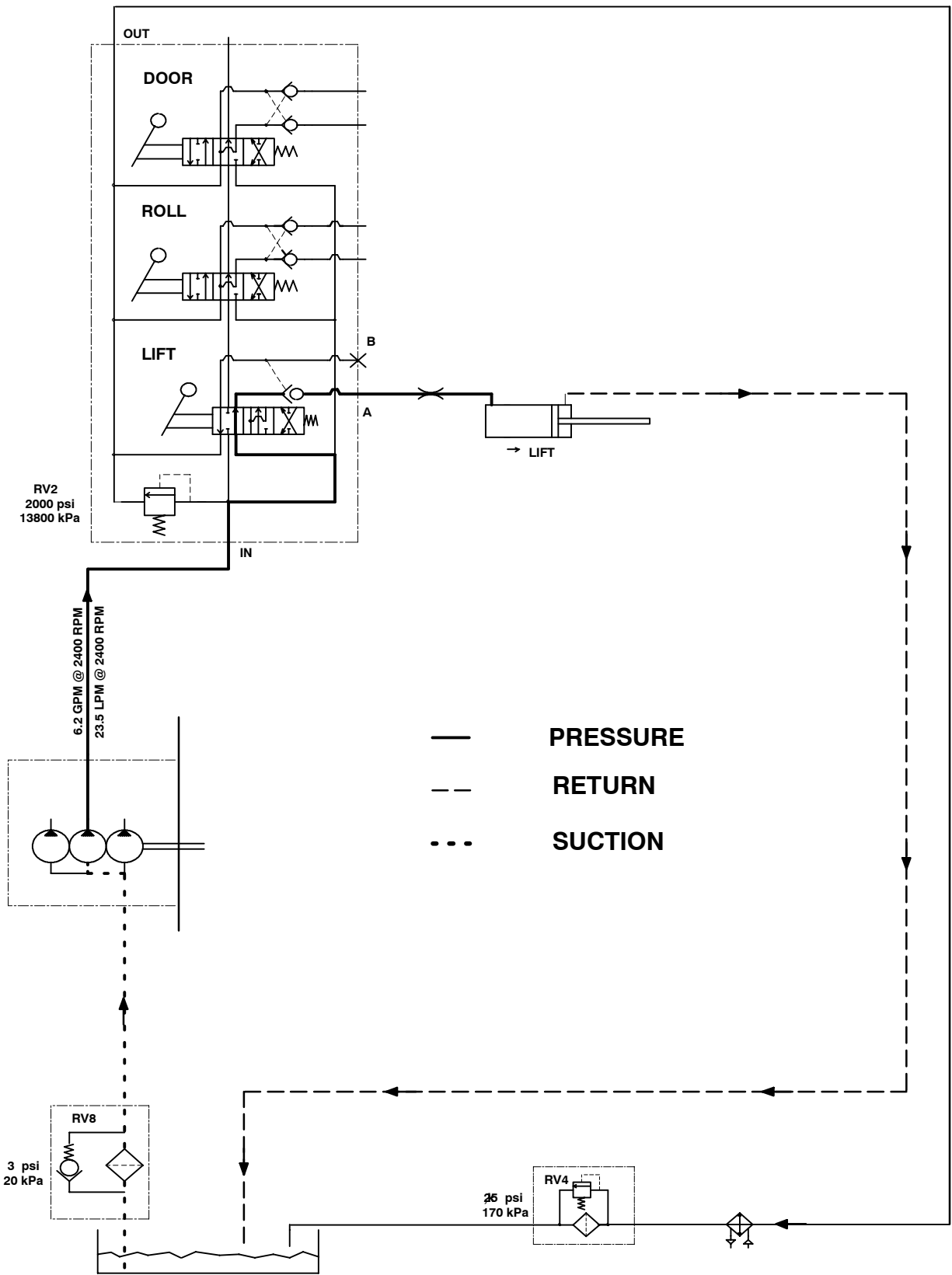

800 / 810 DOOR OPEN

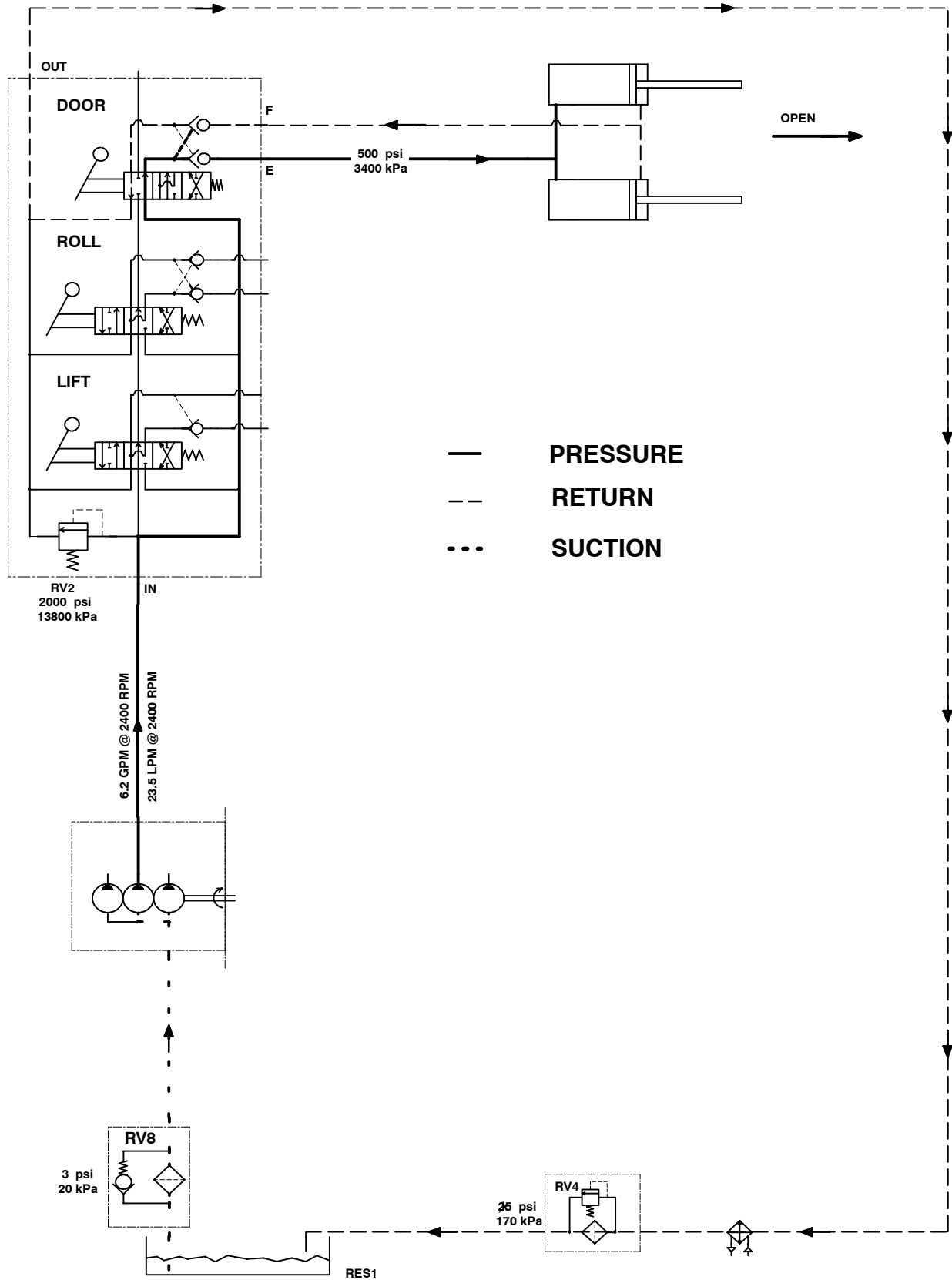

800 / 810 DOOR CLOSE

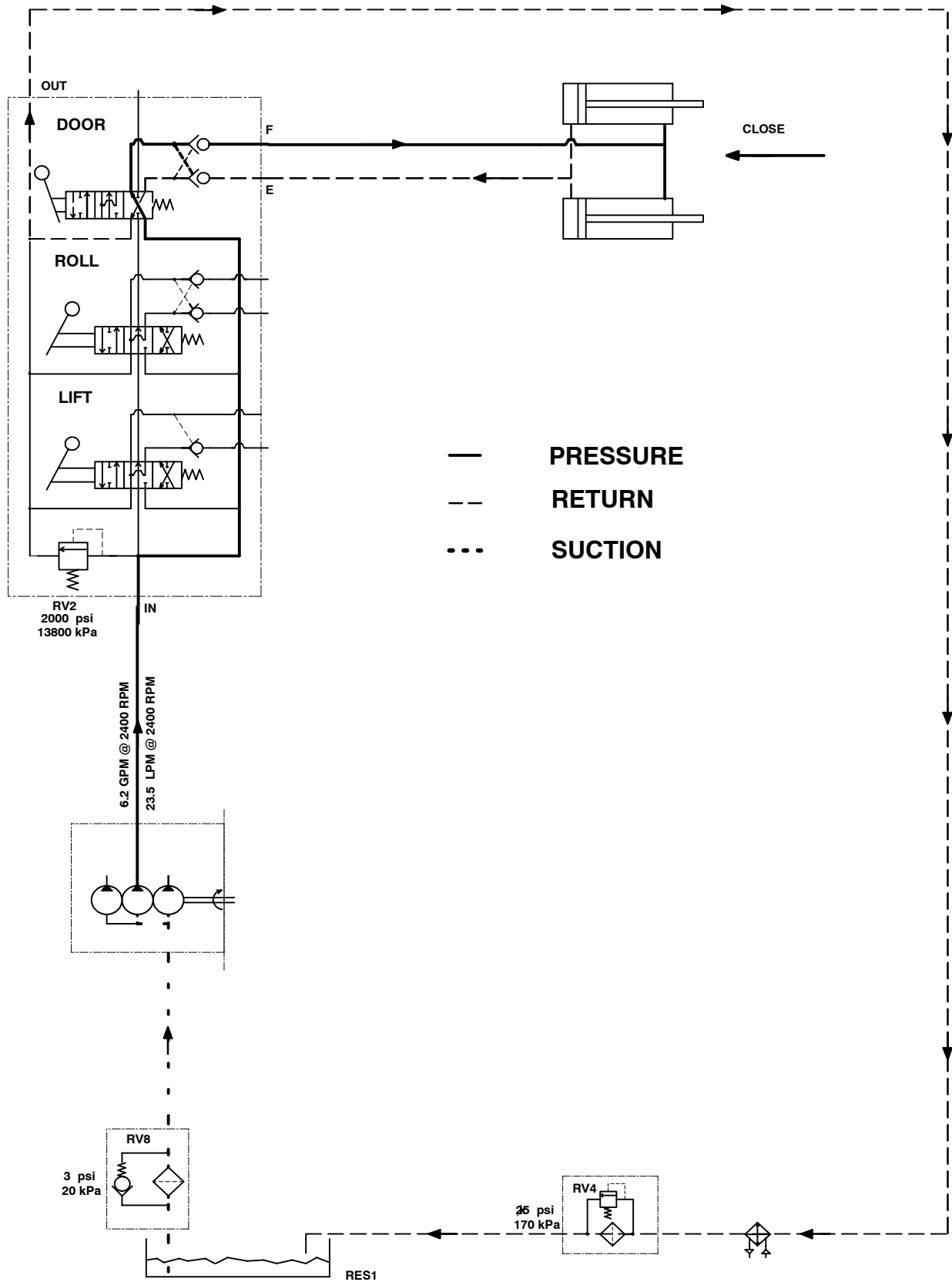

800 / 810 ROLL IN

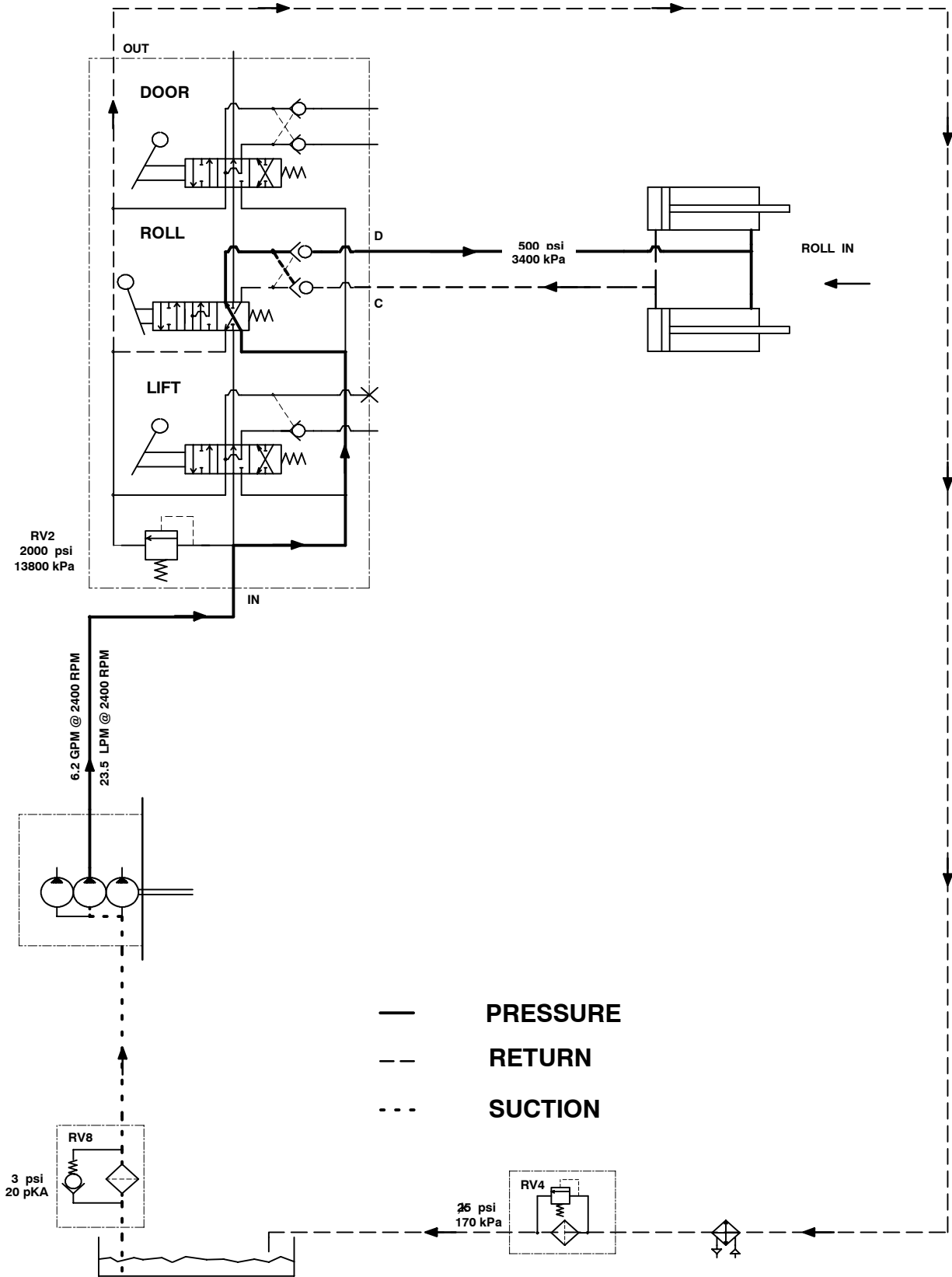

800 / 810 ROLL OUT

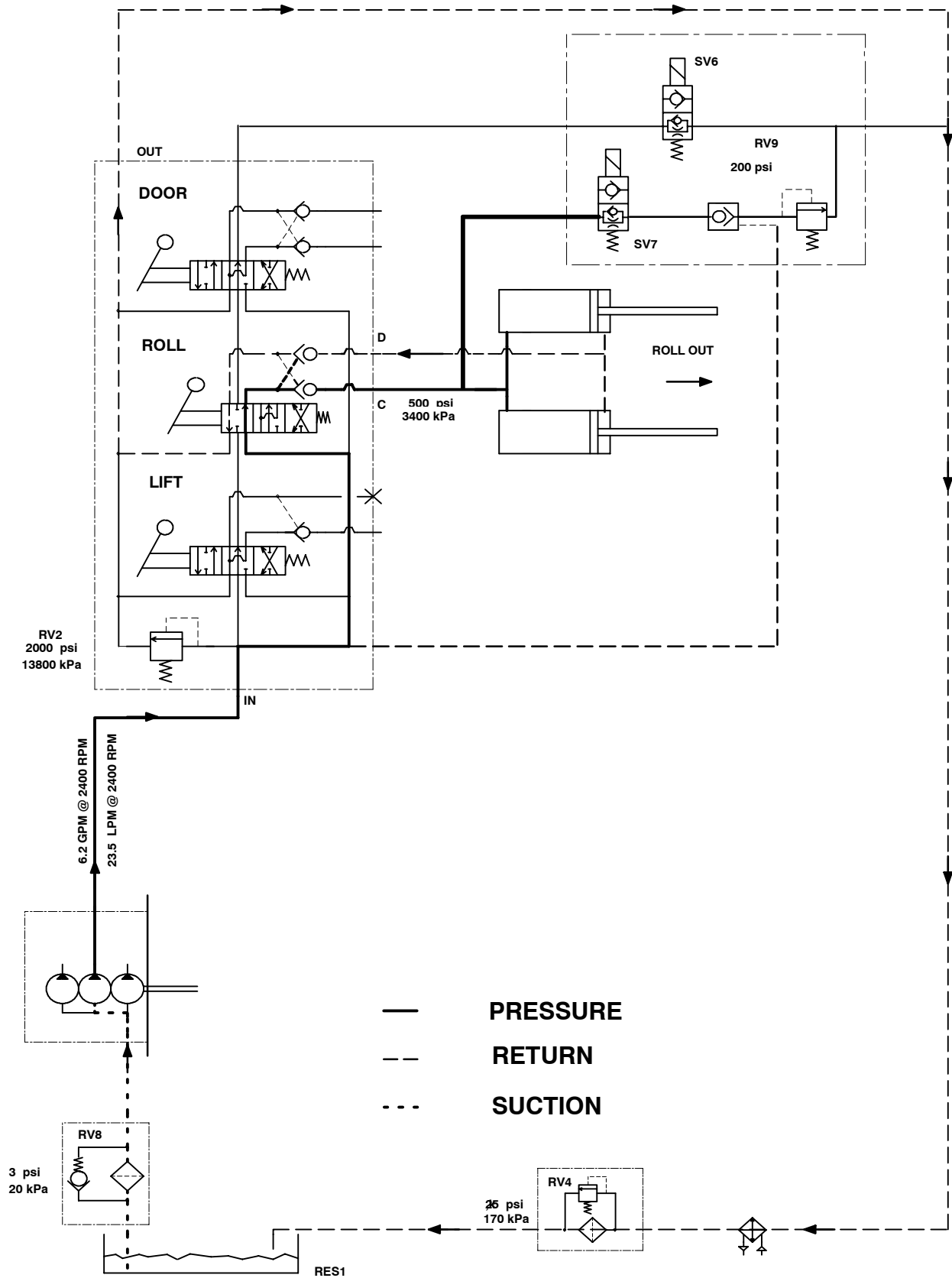

800 / 810 RIGHT TURN

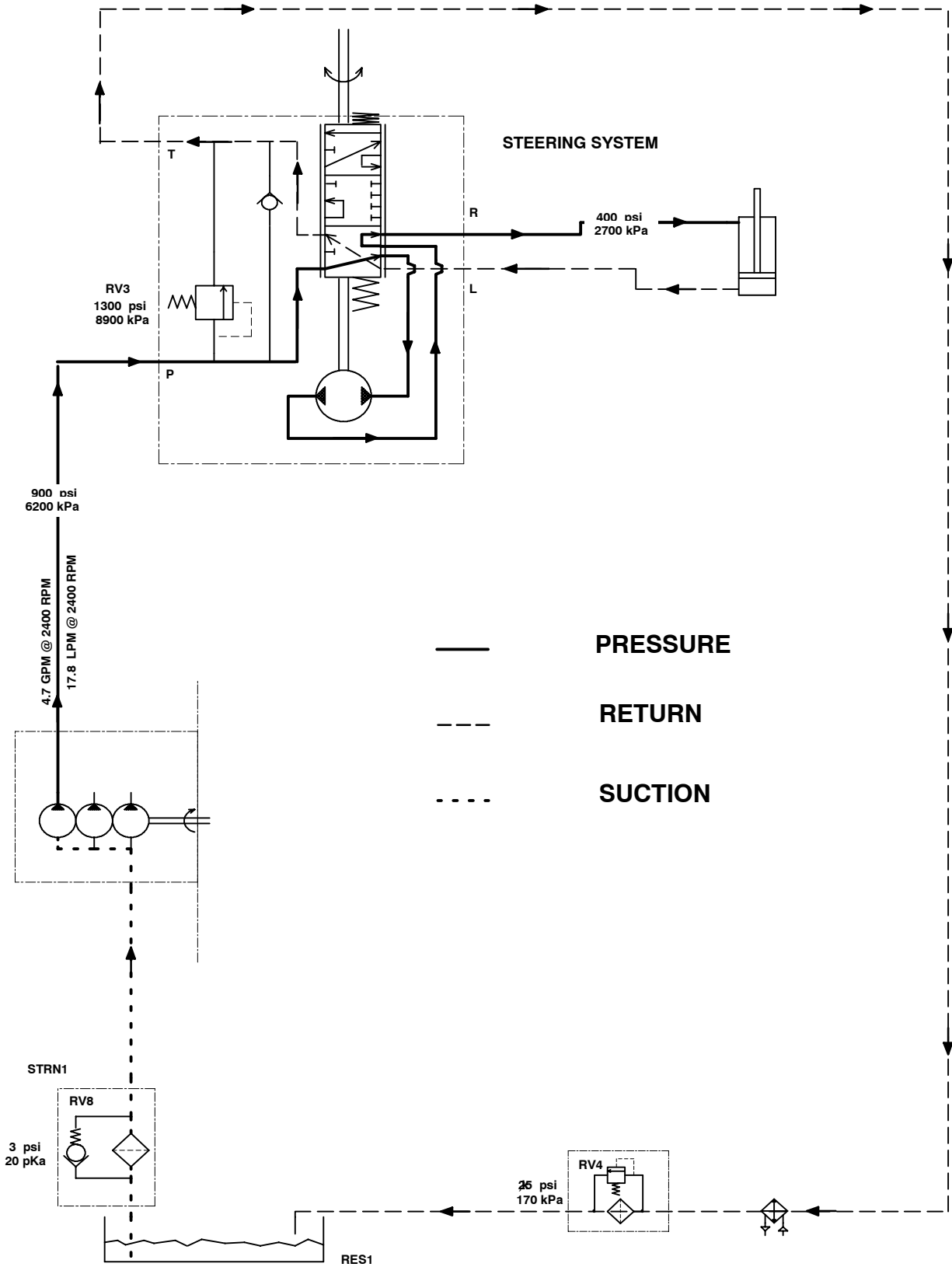

800 / 810 LEFT TURN

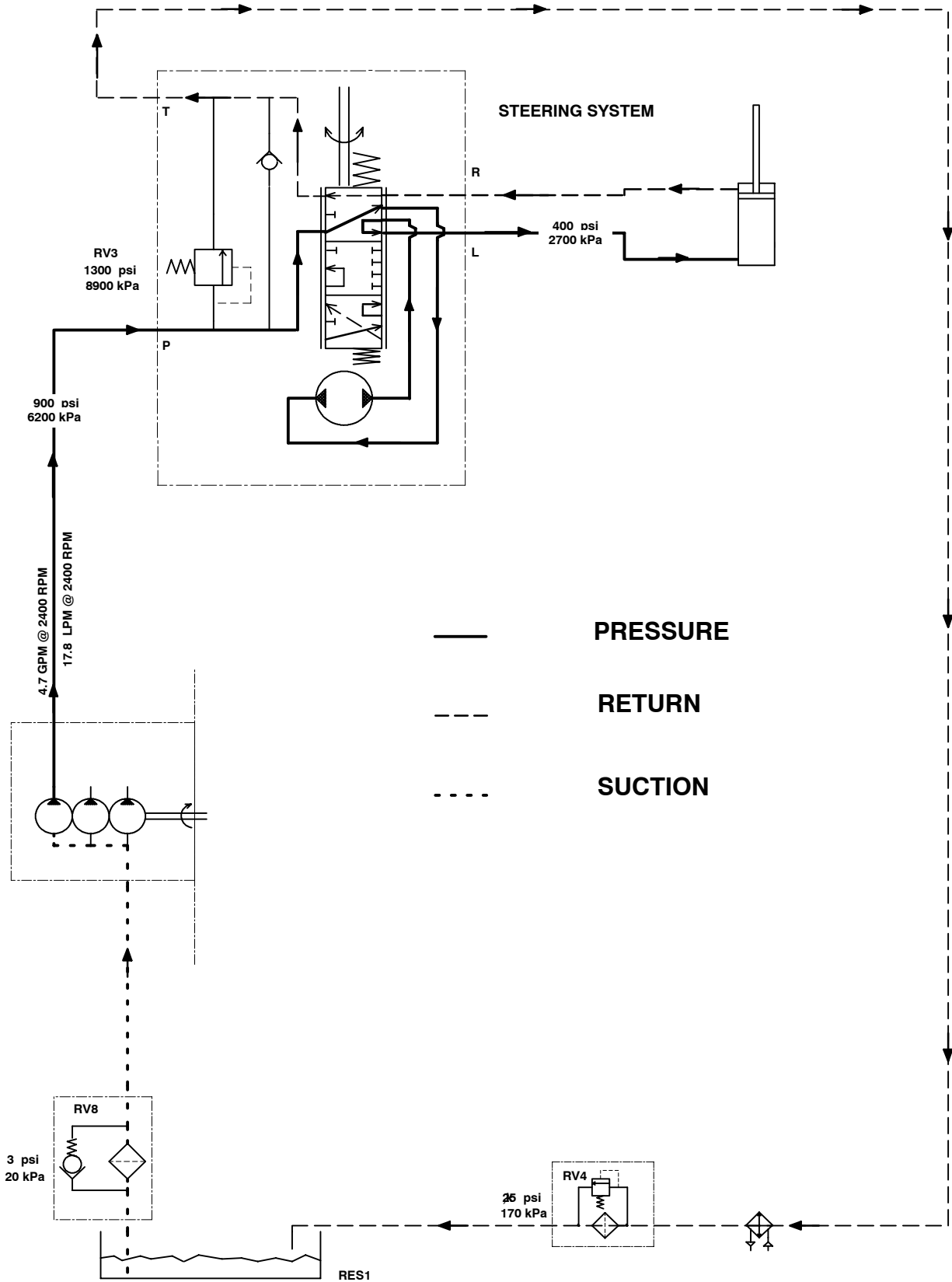

HYDRAULICS

800/810 COOLANT FAN

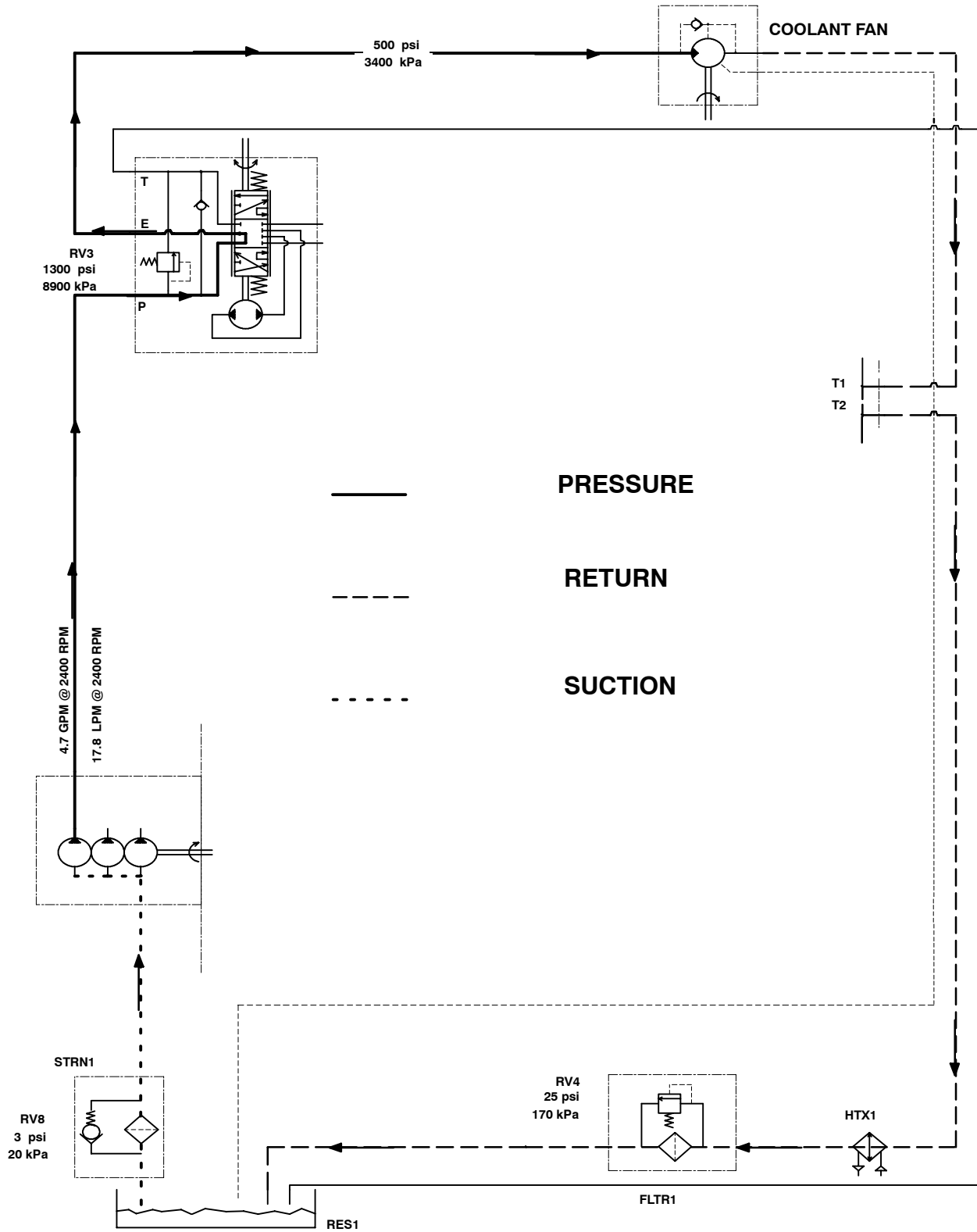

**Eaton
Hydraulics
Division**

Repair Information

A Series Char-Lynn® Motors

001 002 003

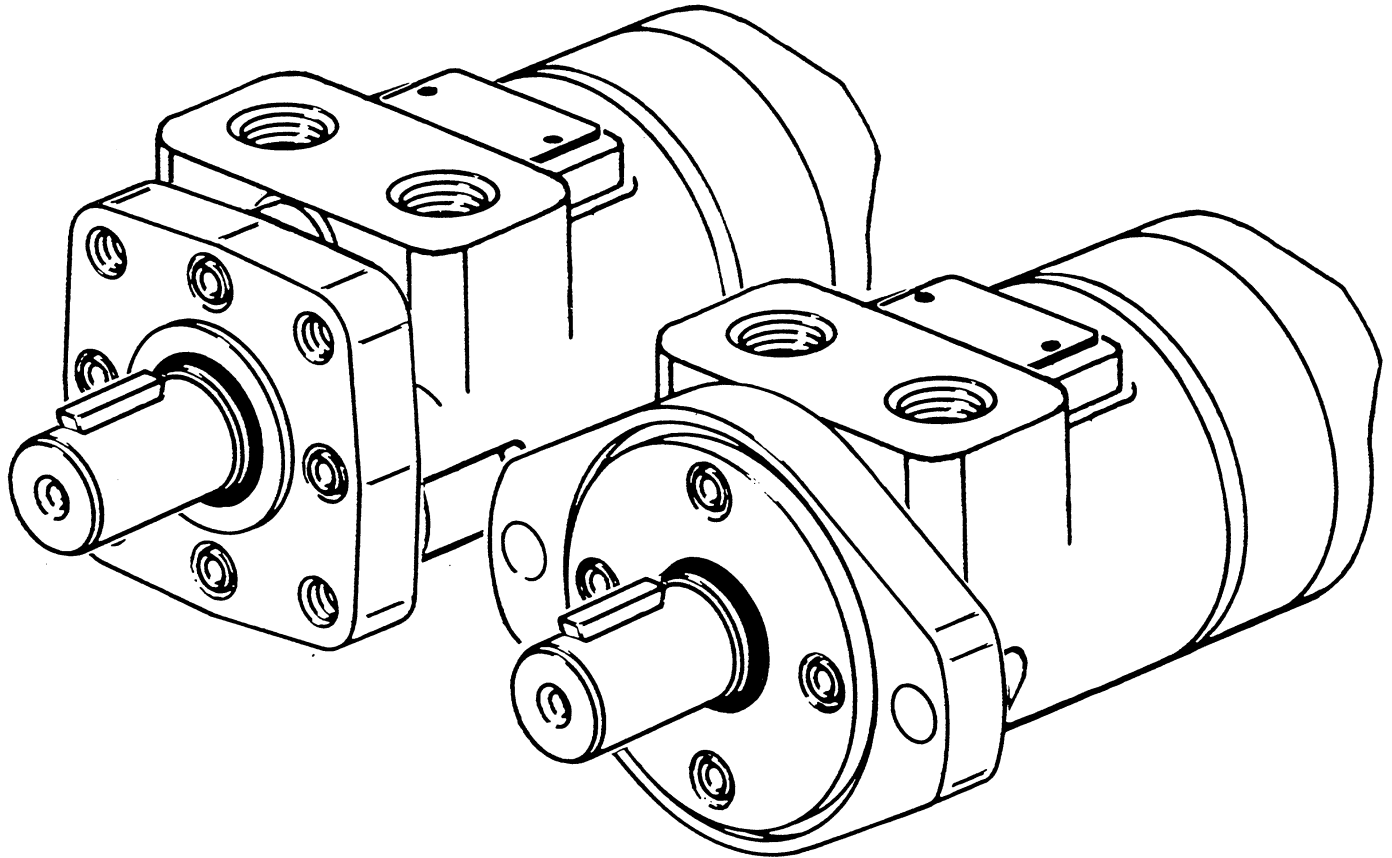

EATON

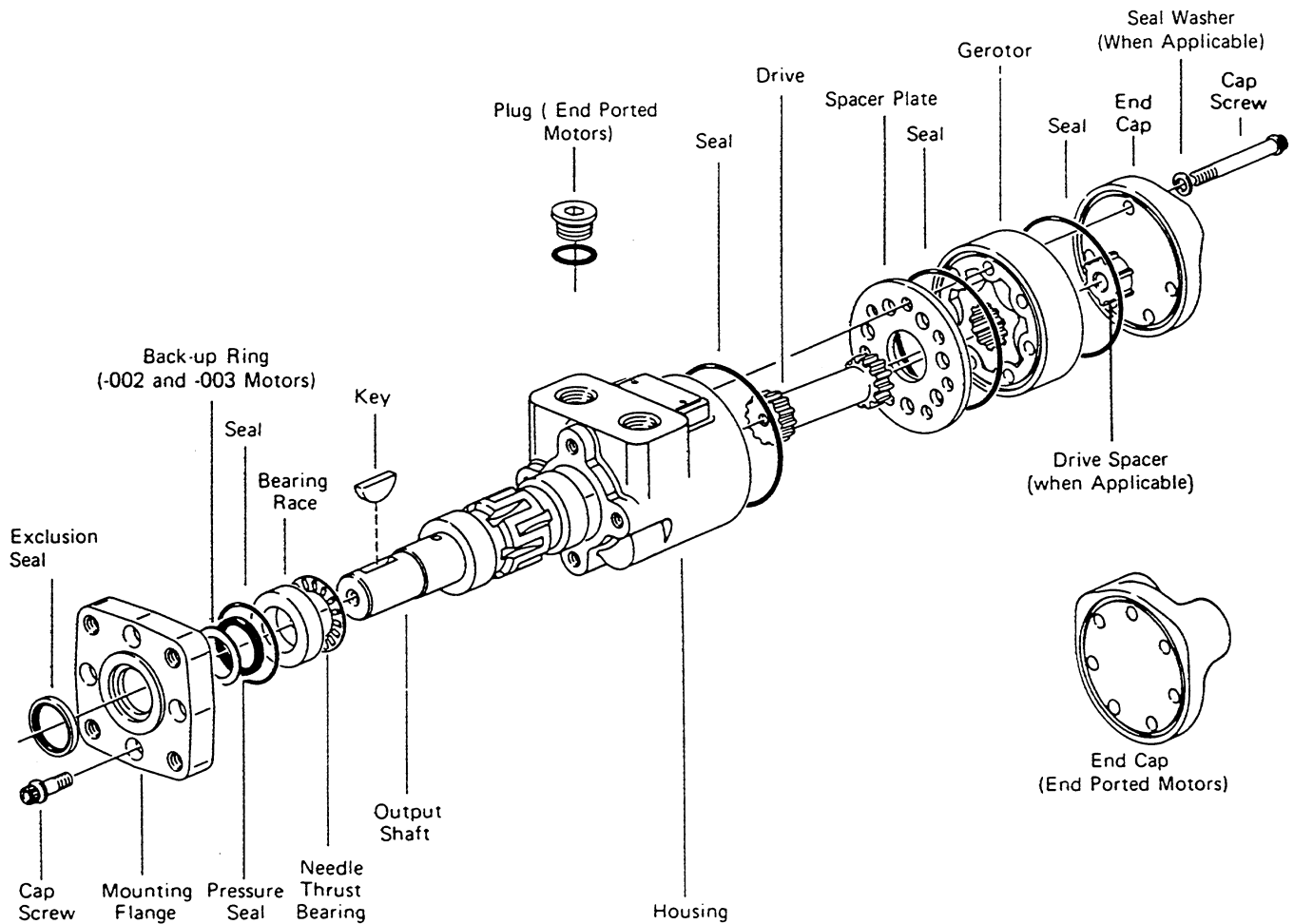

Tools required for disassembly and reassembly.

- Torque wrench (300 lb-in [34Nm] capacity)
- 12-16 in. [300-400mm] breaker bar
- * 5/16 –12 point socket no. 5422 (Heavy Duty 500 lb-in [56Nm] Capacity)
- Small screwdriver (6-8x1/4 in. [150-200x6mm] flat blade), see page 5 for tooling information.
- * Shaft pressure seal installation tool for 001 motor P/N 600470, for 002 and 003 motors P/N 600523
- * Seal sleeve or bullet P/N 600304 (1 in. dia. shaft), P/N 600466 (7/8 in. dia. shaft)

*Tools available—by special order—through our service department.

Repair Information

A Series Char-Lynn Motors Disassembly

Instructions in this manual are for standard A Series Motors (130-XXXX-001, 002 and 003).

Cleanliness is extremely important when repairing these motors. Work in a clean area. Before disconnecting lines, clean port area of motor. Remove key when used. Check shaft and key slot. Remove burrs, nicks and sharp edges. Before disassembly, drain oil from motor. Then plug ports and thoroughly clean exterior of motor.

Although not all drawings show the motor in a vise, we recommend that you keep the motor in a vise during disassembly. Follow the clamping procedures explained throughout the manual.

Gerotor End

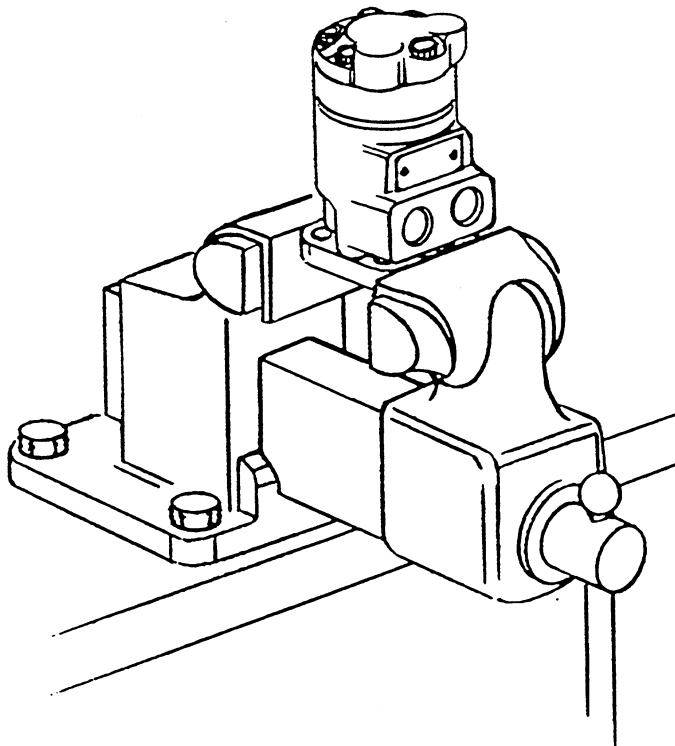

Figure 1

1 Place motor in vise and clamp across edge of flange with output shaft down. When clamping, use protective device on vise such as special soft jaws, pieces of hard rubber or board. See Figure 1.

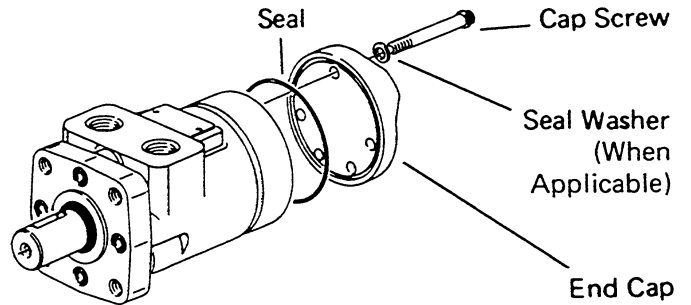

Figure 2

2 Remove cap screws and seal washers (when applicable). See Figure 2.

3 Remove end cap.

4 Remove seal from end cap.

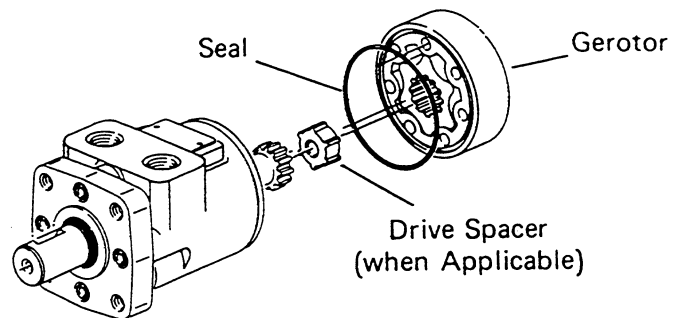

Figure 3

5 Remove gerotor.

6 Remove seal from gerotor (Figure 3).

7 Remove drive spacer if applicable.

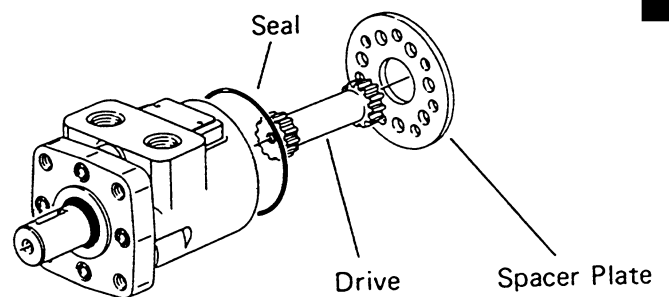

Figure 4

- 8 Remove drive. See Figure 4.
- 9 Remove spacer plate.
- 10 Remove seal from housing.
- 11 Remove output shaft from housing.
- 12 Remove needle thrust bearing from shaft or housing.

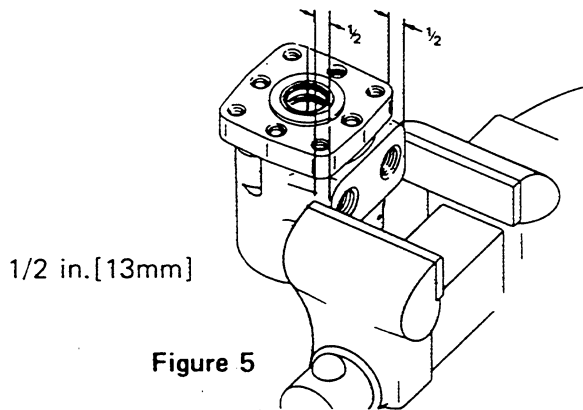

Figure 5

13 Reposition motor in vise. Clamp across ports as shown in Figure 5. Do not clamp on side of housing. Excessive clamping pressure on side of housing causes distortion.

14 Remove cap screws from mounting flange. These screws are assembled with Loctite to hold them in place.

The screws will require 300-400 lb-in [35-45 Nm] of torque to break loose and 100 lb-in [11 Nm] torque to remove. Do not use impact wrench on Loctited screws. This could result in rounded heads or broken sockets.

Note: If torque higher than given above is required to break screws loose, apply heat according to following instructions:

4

When heated, Loctite partially melts. This reduces torque required to remove screw. Use small flame propane torch to heat small area of housing where screw enters. See Figure 6. **Be careful not to overheat housing** and damage motor. Gradually apply torque to screw with **socket** wrench as heat is applied for 8 to 10 seconds. As soon as screw breaks loose, remove heat from housing. Continue turning screw until it is completely removed.

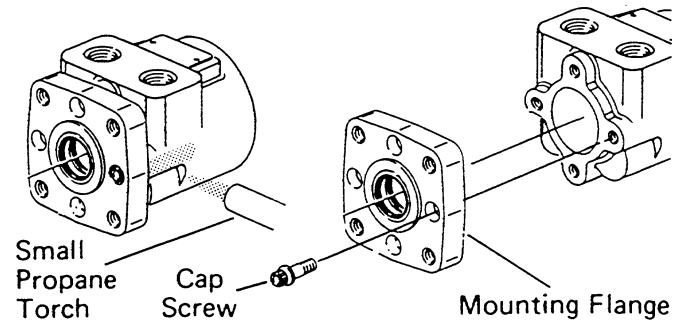

Figure 6

15 Remove motor from vise. Place motor on clean flat surface. Carefully remove flange from housing.

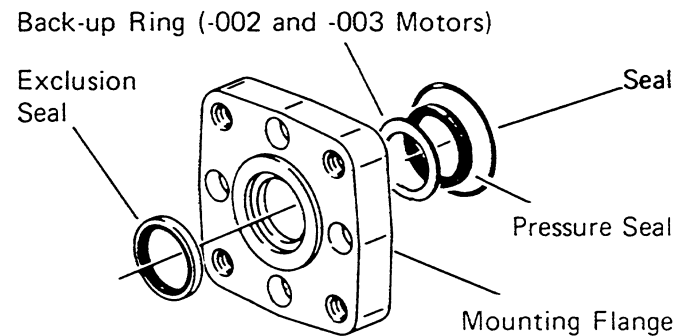

Figure 7

16 Exclusion seal, back-up ring, pressure seal and seal will come off with flange (Figure 7). Use seal removal tool, shown in Figures 8 and 9, to remove exclusion and pressure seals.

Important: Be careful not to scratch seal cavity O.D. This could create a leak path.

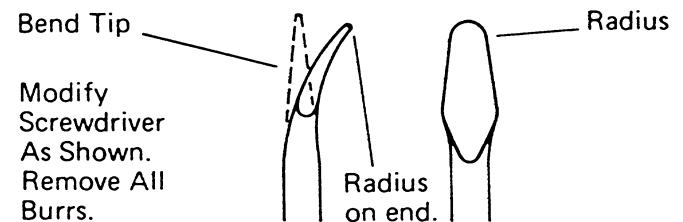

Figure 8

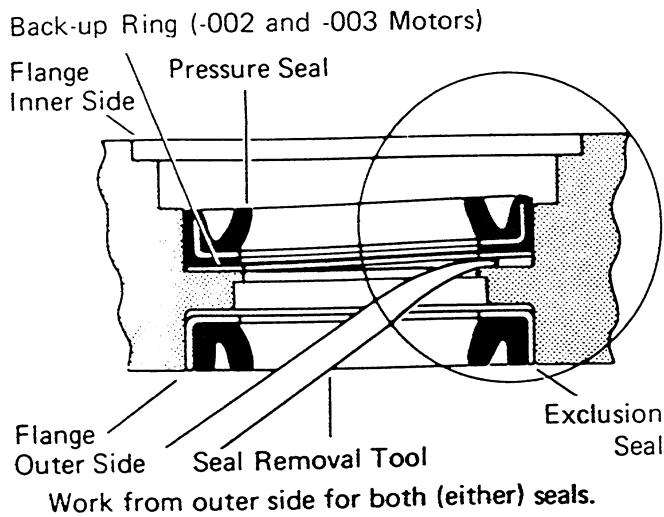

Figure 9

Reassembly

Shaft End

Check all mating surfaces. Replace any parts with scratches or burrs that could cause leakage or damage. Clean all metal parts in clean solvent. Blow dry with air. Do not wipe parts with cloth or paper towel because lint or other matter could get into the hydraulic system and cause damage.

Check around key slot and chamfered area of shaft for burrs, nicks or sharp edges that could damage seals during reassembly. Remove nicks or burrs with a hard smooth stone (such as an Arkansas stone). Do not file or grind motor parts.

Note: Lubricate all seals with petroleum jelly. Use new seals when reassembling motor. Refer to parts list 6-130 for proper seal kit numbers.

Important: Do not stretch seals before installing them.

Cleanliness is extremely important in the successful application of Loctite. Before Loctite can be applied, the parts should be cleaned as follows:

Note: Fully cured Loctite resists most solvents, oils, gasoline and kerosene and is not affected by cleaning operations. It is not necessary to remove cured Loctite that is securely bonded in tapped holes; however, any loose particles of cured Loctite should be removed.

a. Wash the housing with solvent to remove oil, grease and debris. Pay particular attention to four tapped holes on flange end.

b. Blow dry with compressed air. Clean and dry tapped holes.

c. Wire brush screw threads to remove cured Loctite and other debris. Discard any screws that have damaged threads or rounded heads.

d. Wash screws with non-petroleum base solvent. Blow dry with compressed air.

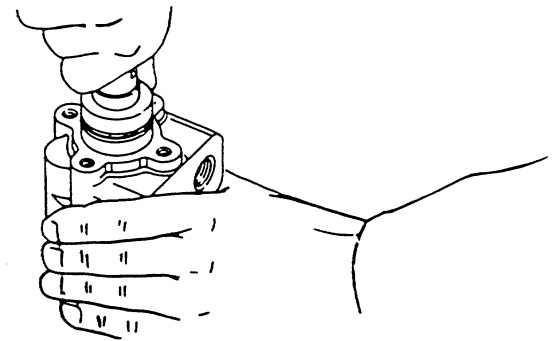
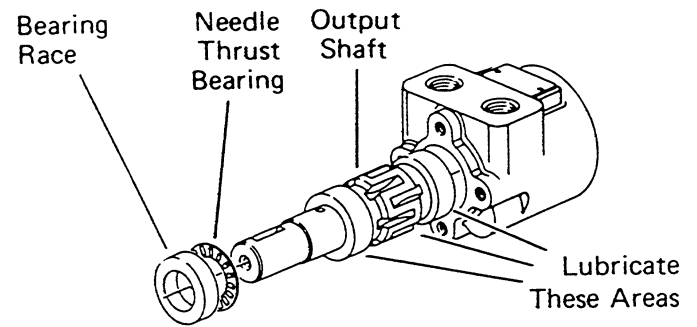
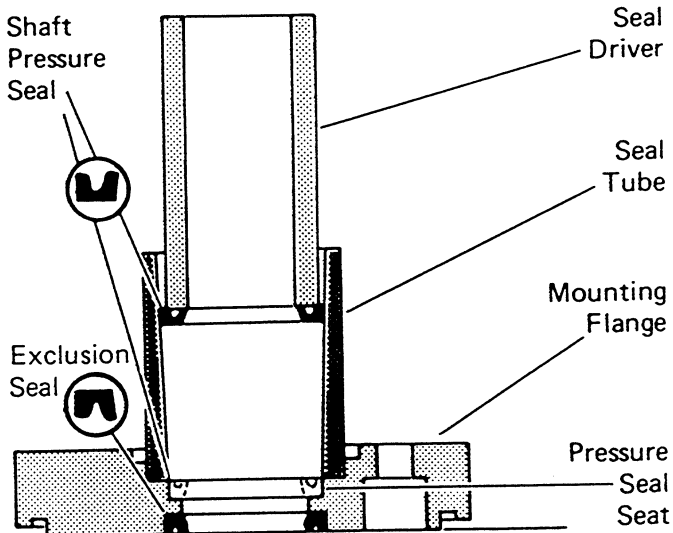

Figure 10

17 Lubricate output shaft with hydraulic oil, then install shaft in housing. See Figure 10.

Important: Do not permit oil to get into the four tapped holes.

18 Install needle thrust bearing, then bearing race on shaft. Pull shaft partially out of housing. Push all three parts in housing together. See Figure 10. The bearing race must rotate freely when in position.



Seal Installation Tool
 No. 600470 -001 Motors
 No. 600523 -002 and -003 Motors

Figure 11

19 Install exclusion seal in flange. See Figure 11. Carefully press exclusion seal into place.

20 Visually check seal seat in mounting flange for scratches or other marks that might damage the pressure seal. Check for cracks in flange that could cause leakage.

21 Lubricate I.D. of seal tube and O.D. of shaft pressure seal with light film of clean petroleum jelly. Align small I.D. end of seal tube with seal seat in mounting flange. Install back-up ring and pressure seal in tube with lips of seal face up. See Figure 11. Insert seal driver in tube and firmly push seal seat with a rotating action.

Important: After installing seal in flange, examine seal condition. If damaged or improperly installed, you must replace it before continuing with reassembly.

22 Install 1⁵/₁₆ in. [49 mm] I.D. seal in flange.

23 It is recommended to apply a light coat of Loctite Primer NF in tapped holes of housing. Allow primer to air dry for at least 1 minute. Do not force dry with air jet; the primer will blow away.

Use of primer is optional. With primer, Loctite curing time is approximately 15 minutes. Without primer, curing time is approximately 6 hours.

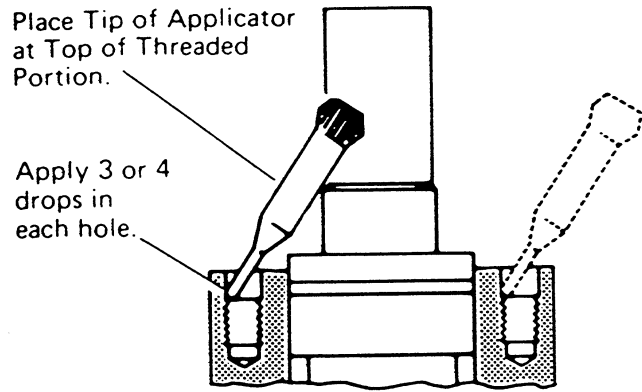

Figure 12

24 Apply 3 or 4 drops of Loctite sealant at top of thread for each of four holes in housing. See Figure 12. Do not allow parts with Loctite applied to come in contact with any metal parts other than those for assembly. Wipe off excess Loctite from housing face, using a non-petroleum base solvent.

Do not apply Loctite to threads more than 15 minutes before installing screws. If housing stands for more than 15 minutes, repeat application. No additional cleaning or removal of previously applied Loctite is necessary.

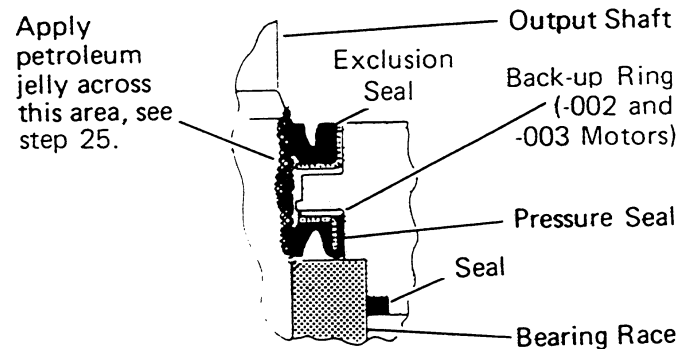

Figure 13

25 Before installing flange and seal assembly over shaft, place protective sleeve or bullet over shaft. Then lubricate space between exclusion seal and pressure seal, as well as lips of both seals. See Figure 13.

Install flange. Rotate flange slowly while pushing down over shaft. Be careful not to invert or damage seals.

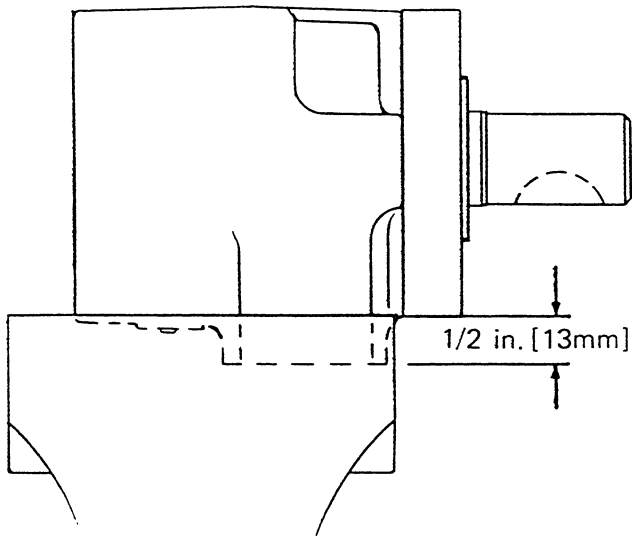

Figure 14

26 After removing bullet, clamp motor in vise as shown in Figure 14. Make sure shaft cannot fall out. Install **dry** screws and alternately torque them immediately to 250 lb-in [28 Nm]. If you use primer, allow to cure for **10 to 15 minutes**. Without primer, allow 6 hours curing time before subjecting motor to high torque reversals. On all other applications, you can run motor immediately.

If you use new screws, make sure they are the correct length: $\frac{7}{8}$ in. [22 mm] under head length. See parts list for correct part number.

Gerotor End

27 Reposition motor with gerotor end up, then clamp across ports. Do not clamp on side of housing.

Important: To aid installation of seals, apply light coat of clean petroleum jelly to seals. Do not stretch seals before installing them in groove.

28 Pour approximately 35 cc of clean hydraulic oil in output shaft cavity.

29 Install $2\frac{7}{8}$ in. [73 mm] I.D. seal in housing seal groove. Avoid twisting seal.

Timing Procedure

a. Install drive. Use felt tip marker to mark one drive tooth. Align this tooth with timing dot on shaft.

Note: If drive is not symmetrical, install larger splined end into shaft.

b. Install spacer plate.

c. Install $2\frac{7}{8}$ in. [73 mm] I.D. seal in gerotor seal groove. Carefully place gerotor on spacer plate, seal side toward spacer plate.

Standard Rotation Align any star point with tooth marked on drive. See Figure 15.

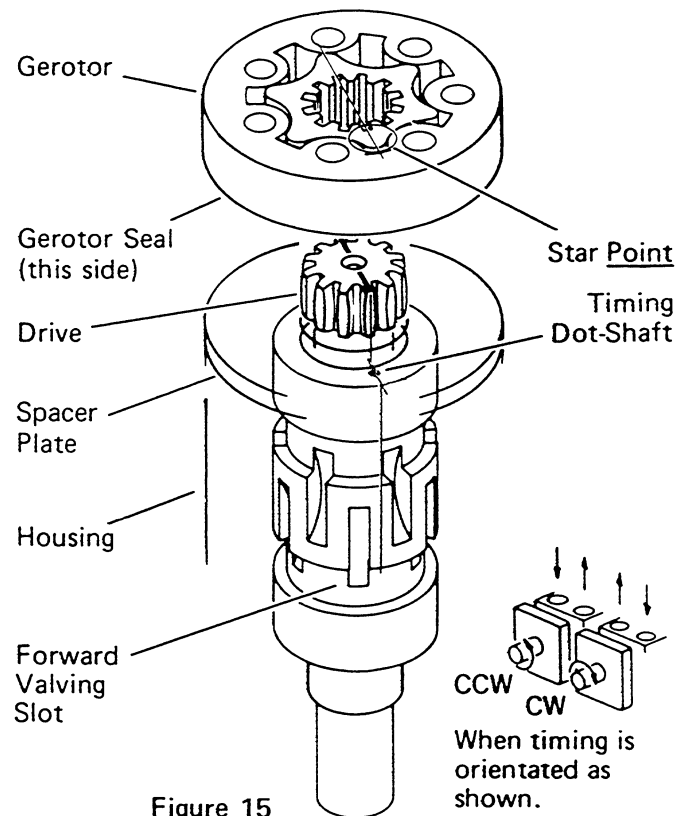

Figure 15

Reverse Rotation Align any star valley with marked tooth. See Figure 16.

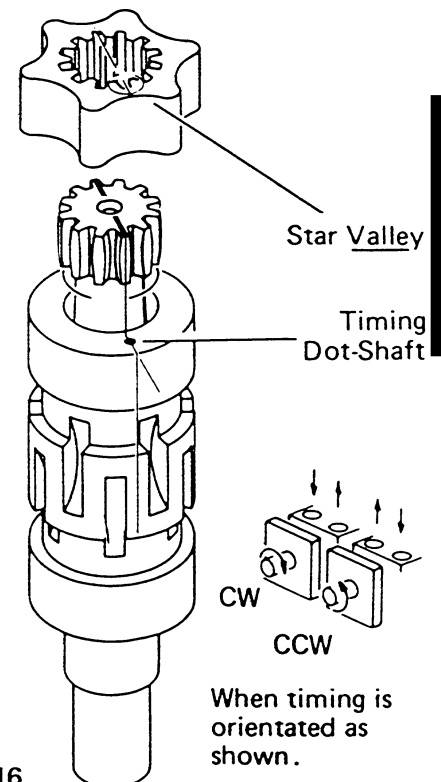

Figure 16

CHAR-LYNN®
HYDRAULIC MOTOR
"A" SERIES
REPAIR MANUAL
NO. 7-125

Reassembly Continued from Page 7

30 Rotate gerotor to line up bolt holes. Be careful not to disengage star from drive or disturb gerotor seal.

31 Install drive spacer if applicable.

32 Install 27/8 in. [73 mm] seal in end cap. Carefully place end cap on gerotor.

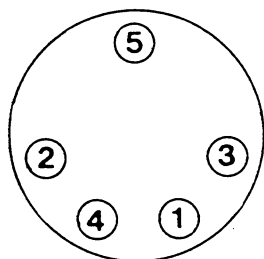

Bolt Torquing Sequence

Figure 17

Each order must include the following information:

- 1 Product Number
- 2 Date Code
- 3 Part Name
- 4 Part Number
- 5 Quantity of Parts

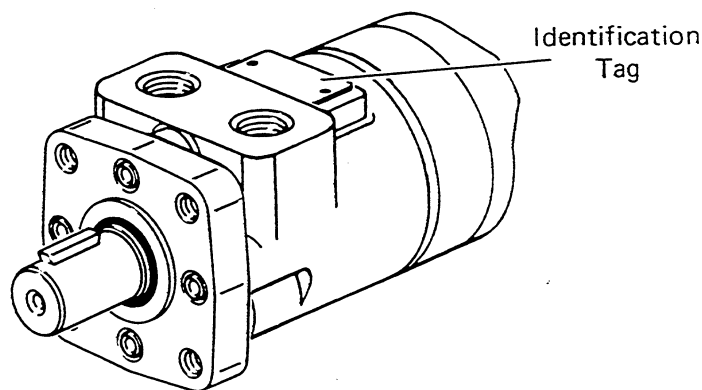

33 Install cap screws and seal washers (if applicable) in end cap. Pretighten screws to 40 lb-in [7, 4 Nm]. Make sure seals are properly seated. Then torque screws 275-300 lb-in [30-34 Nm] in sequence, as shown in Figure 17.

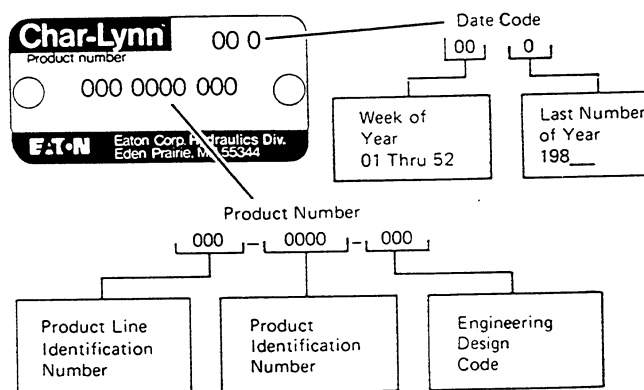

Eaton Corporation **Hydraulics Division** 15151 Highway 5 Eden Prairie, MN 55344 Telephone (612) 937-9800



REVISED MAY, 1988
FORM NO. 7-125-58

NO. 7-117

**Eaton
Hydraulics
Division**

Repair Information

H Series Char-Lynn® Motors

007 008 009

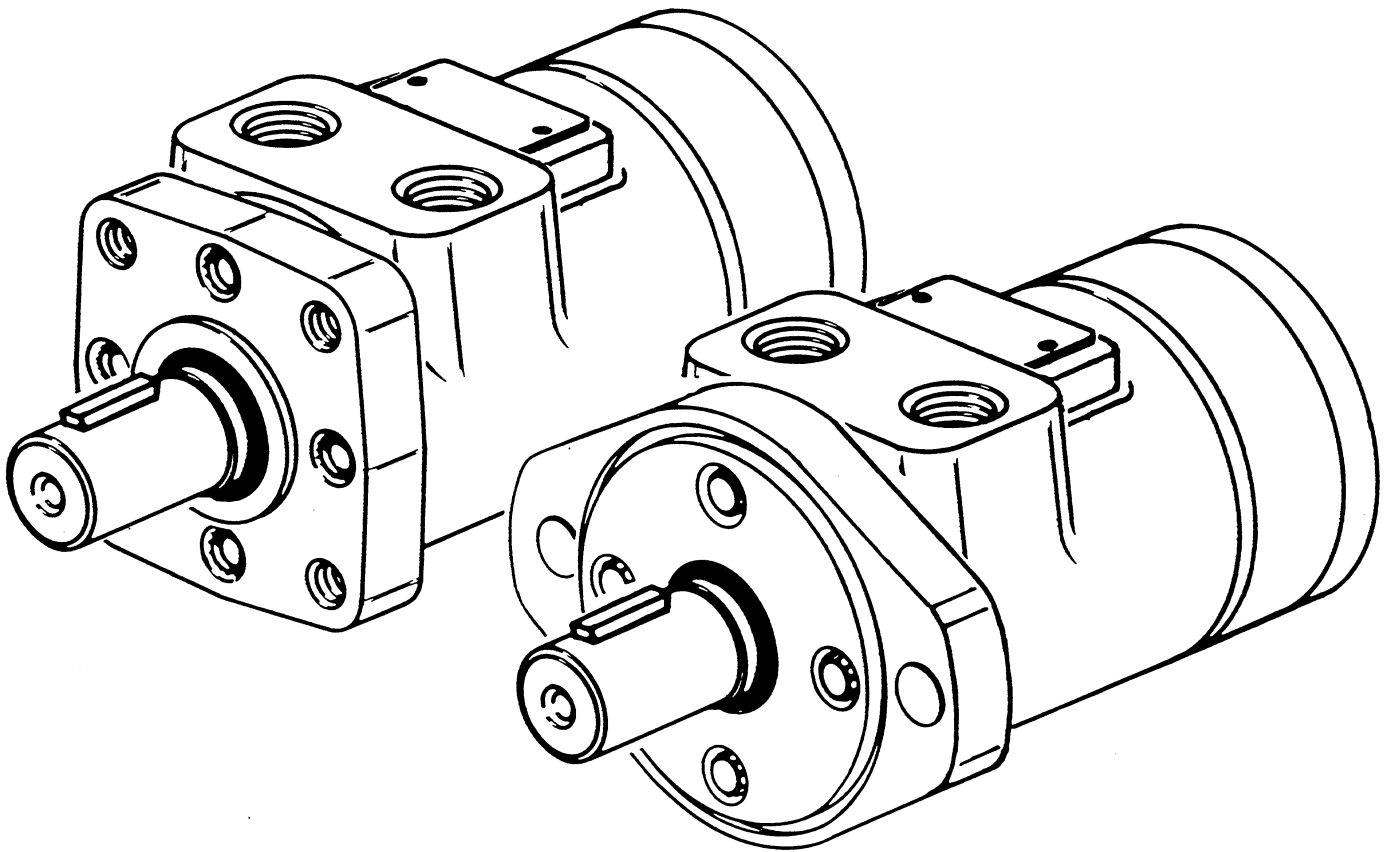

EAT•N

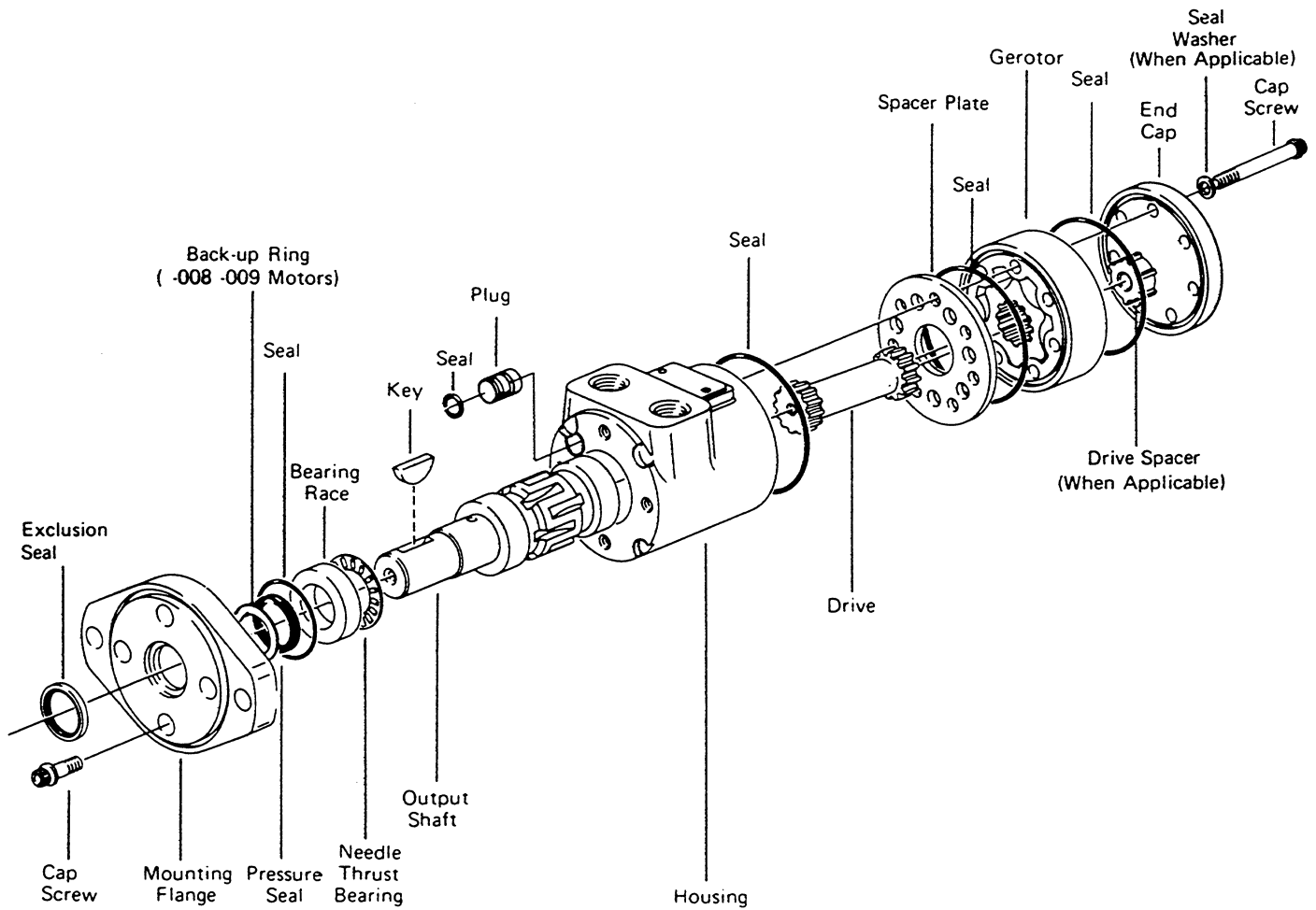

Tools required for disassembly and reassembly.

- Torque wrench (300 lb-in [34Nm] capacity)
- 12-16 in. [300-400mm] breaker bar
- * 5/16 in. -12 point socket no. 5422 (Heavy Duty 500 lb-in [56Nm] Capacity)
- Small screwdriver (6-8x1/4 in. [150-200x6mm] flat blade), see page 5 for tooling information.
- 3/16 in. [5mm] hex key
- * Shaft pressure seal installation tool for 007 motor P/N 600470, for 008 and 009 motors P/N 600523
- * Seal sleeve or bullet P/N 600304 (1 in. dia. shaft), P/N 600466 (7/8 in. dia. shaft)

* Tools available—by special order—through our service department.

Repair Information

H Series Char-Lynn Motors Disassembly

Instructions in this manual are for H Series Motors (101-XXXX-007, 008 and 009).

Cleanliness is extremely important when repairing these motors. Work in a clean area. Before disconnecting lines, clean port area of motor. Remove key when used. Check shaft and key slot. Remove burrs, nicks and sharp edges. Before disassembly, drain oil from motor. Then plug ports and thoroughly clean exterior of motor.

Although not all drawings show the motor in a vise, we recommend that you keep the motor in a vise during disassembly. Follow the clamping procedures explained throughout the manual.

Gerotor End

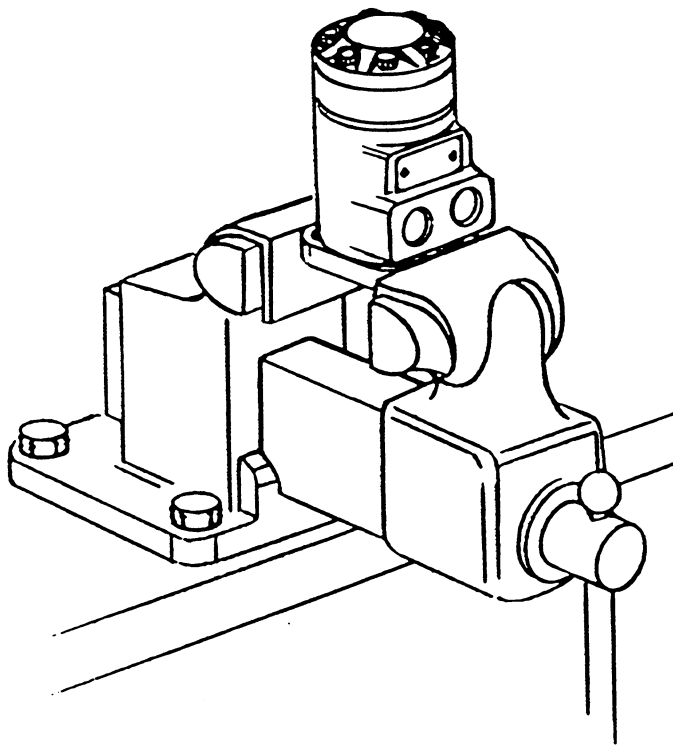

Figure 1

1 Place motor in vise and clamp across edge of flange with output shaft down. When clamping, use protective device on vise such as special soft jaws, pieces of hard rubber or board. See Figure 1.

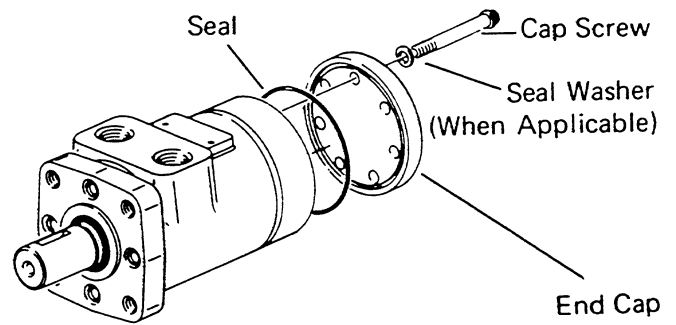

Figure 2

2 Remove cap screws and seal washers (when applicable). See Figure 2.

3 Remove end cap.

4 Remove seal from end cap.

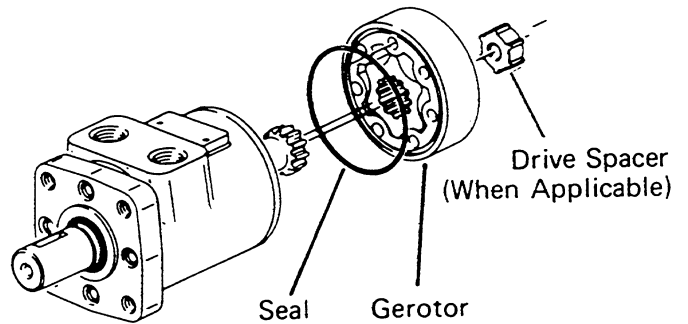

Figure 3

5 Remove gerotor.

6 Remove seal from gerotor (Figure 3).

7 Remove drive spacer if applicable.

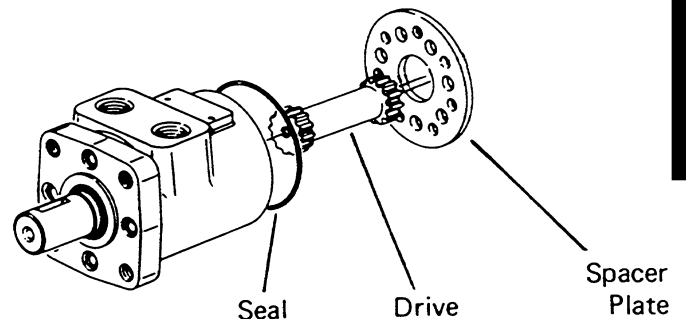

Figure 4

8 Remove drive. See Figure 4.

9 Remove spacer plate.

10 Remove seal from housing.

- 11 Remove output shaft from housing.
- 12 Remove needle thrust bearing from shaft or housing.

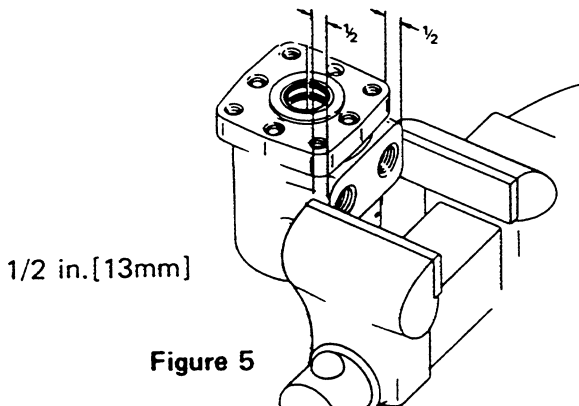

Figure 5

- 13 Reposition motor in vise. Clamp across ports as shown in Figure 5. Do not clamp on side of housing. Excessive clamping pressure on side of housing causes distortion.

- 14 Remove cap screws from mounting flange. These screws are assembled with Loctite to hold them in place.

The screws will require 300-400 lb-in [35-45 Nm] of torque to break loose and 100 lb-in [11 Nm] torque to remove. Do not use impact wrench on Loctited screws. This could result in rounded heads or broken sockets.

Note: If torque higher than given above is required to break screws loose, apply heat according to following instructions:

When heated, Loctite partially melts. This reduces torque required to remove screw. Use small flame propane torch to heat small area of housing where screw enters. See Figure 6. **Be careful not to overheat housing** and damage motor. Gradually apply torque to screw with **socket** wrench as heat is applied for 8 to 10 seconds. As soon as screw breaks loose, remove heat from housing. Continue turning screw until it is completely removed.

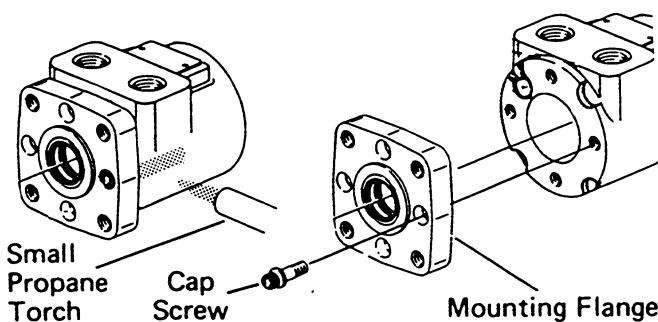

Figure 6

- 15 Carefully remove flange from housing.

Important: Some motors may have a quad seal and back-up ring in place of the pressure seal. The quad seal and back-up ring are no longer available and are replaced by the pressure seal. They are interchangeable, but some precautions must be taken to insure proper installation. Follow the reassembly instructions.

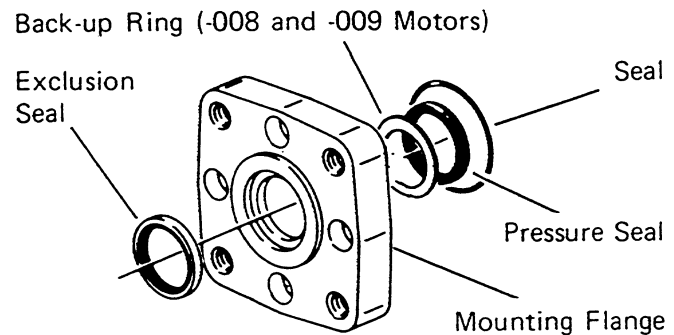

Figure 7

- 16 Exclusion seal, back-up ring, pressure seal and seal will come off with flange (Figure 7). Use seal removal tool, shown in Figures 8 and 9, to remove exclusion and pressure seals.

Important: Be careful not to scratch seal cavity O.D. This could create a leak path.

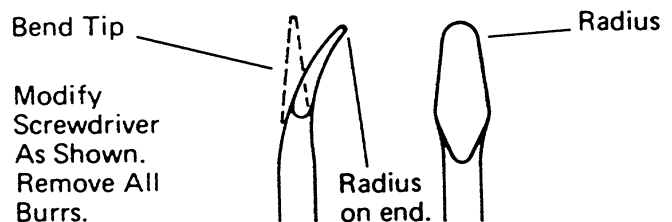

Figure 8

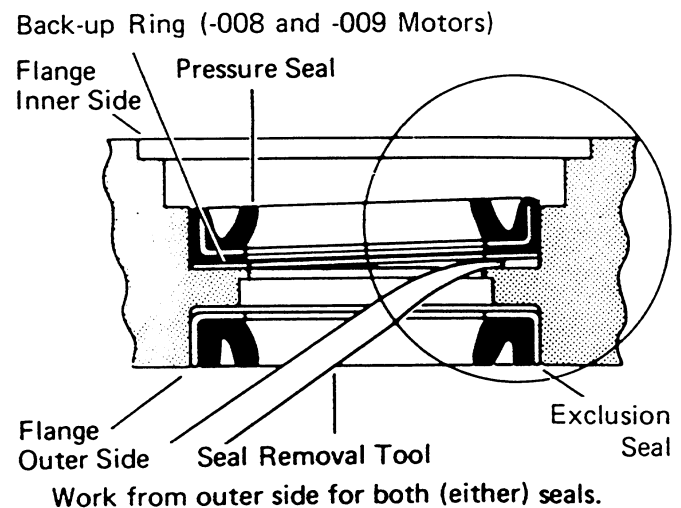

Figure 9

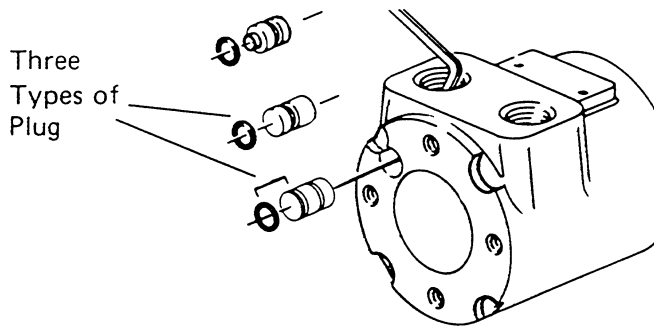

Figure 10

17 A metal plug, with seal, plugs a machining hole in the housing. It is not necessary to remove plug and replace seal unless leakage occurs around plug. To remove plug, insert $\frac{3}{16}$ in. [5 mm] hex key through port opening and push it out. See Figure 10. The 009 plug is not interchangeable with 007 and 008 plugs.

Reassembly

Shaft End

Check all mating surfaces. Replace any parts with scratches or burrs that could cause leakage or damage. Clean all metal parts in clean solvent. Blow dry with air. Do not wipe parts with cloth or paper towel because lint or other matter could get into the hydraulic system and cause damage.

Check around key slot and chamfered area of shaft for burrs, nicks or sharp edges that could damage seals during reassembly. Remove nicks or burrs with a hard smooth stone (such as an Arkansas stone). Do not file or grind motor parts.

Note: Lubricate all seals with petroleum jelly. Use new seals when reassembling motor. Refer to parts list 6-121 for proper seal kit numbers.

Important: Do not stretch seals before installing them.

Cleanliness is extremely important in the successful application of Loctite. Before Loctite can be applied, the parts should be cleaned as follows:

Note: Fully cured Loctite resists most solvents, oils, gasoline and kerosene and is not affected by cleaning operations. It is not necessary to remove cured Loctite that is securely bonded in tapped holes; however, any loose particles of cured Loctite should be removed.

a. Wash the housing with solvent to remove oil, grease and debris. Pay particular attention to four tapped holes on flange end.

b. Blow dry with compressed air. Clean and dry tapped holes.

c. Wire brush screw threads to remove cured Loctite and other debris. Discard any screws that have damaged threads or rounded heads.

d. Wash screws with non-petroleum base solvent. Blow dry with compressed air.

18 If you remove plug and seal, lubricate new seal and install on plug. Some plugs have two o-ring grooves but require only one o-ring. Install o-ring in groove closest to end of plug. Push plug into housing so plug and housing are flush. Be careful not to damage seal.

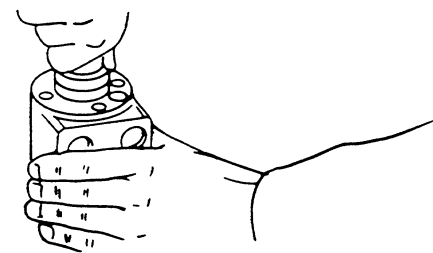
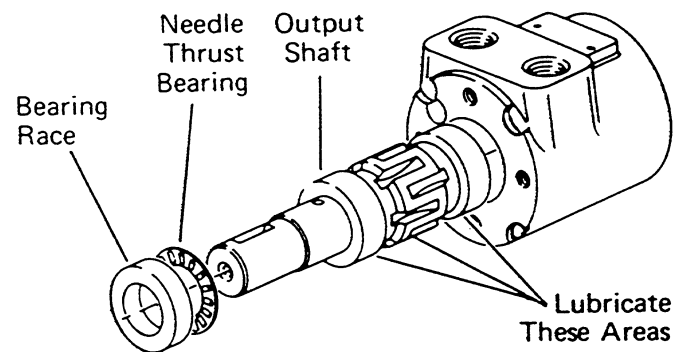
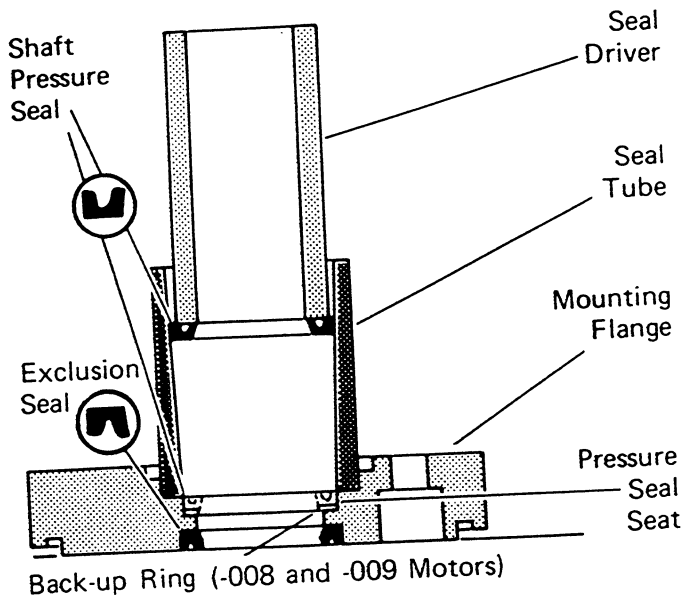

Figure 11

19 Lubricate output shaft with hydraulic oil, then install shaft in housing. See Figure 11.

Important: Do not permit oil to get into the four tapped holes.

20 Install needle thrust bearing, then bearing race on shaft. Pull shaft partially out of housing. Push all three parts in housing together. See Figure 11. The bearing race must rotate freely when in position.



Seal Installation Tool
 No. 600470 (007 Motors)
 No. 600523 (008, 009 Motors)

Figure 12

21 Install exclusion seal in flange. See Figure 12. Carefully press exclusion seal into place.

22 Visually check seal seat in mounting flange for scratches or other marks that might damage the pressure seal. Check for cracks in flange that could cause leakage.

23 Lubricate I.D. of seal tube and O.D. of shaft pressure seal with light film of clean petroleum jelly. Align small I.D. end of seal tube with seal seat in mounting flange. Install back-up ring and pressure seal in tube with lips of seal face up. See Figure 12. Insert seal driver in tube and firmly push seal seat with a rotating action.

Important: After installing seal in flange, examine seal condition. If damaged or improperly installed, you must replace it before continuing with reassembly.

24 Install 1¹⁵/₁₆ in. [49 mm] I.D. seal in flange.

25 It is recommended to apply a light coat of Loctite Primer NF in tapped holes of housing. Allow primer to air dry for at least 1 minute. Do not force dry with air jet; the primer will blow away.

Use of primer is optional. With primer, Loctite curing time is approximately 15 minutes. Without primer, curing time is approximately 6 hours.

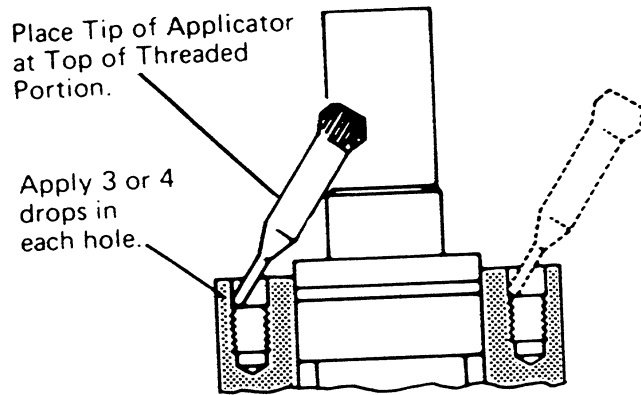

Figure 13

26 Apply 3 or 4 drops of Loctite sealant at top of thread for each of four holes in housing. See Figure 13. Do not allow parts with Loctite applied to come in contact with any metal parts other than those for assembly. Wipe off excess Loctite from housing face, using a non-petroleum base solvent.

Do not apply Loctite to threads more than 15 minutes before installing screws. If housing stands for more than 15 minutes, repeat application. No additional cleaning or removal of previously applied Loctite is necessary.

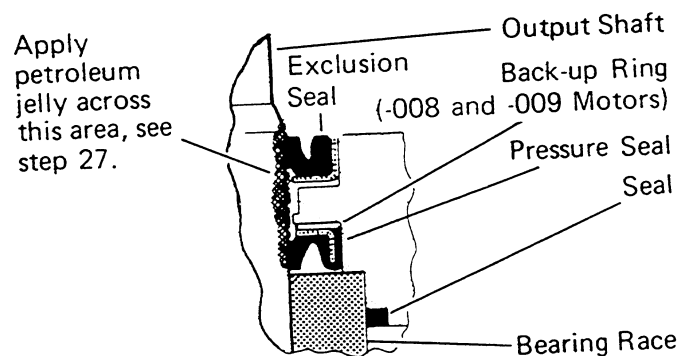

Figure 14

27 Before installing flange and seal assembly over shaft, place protective sleeve or bullet over shaft. Then lubricate space between exclusion seal and pressure seal, as well as lips of both seals. See Figure 14.

Install flange. Rotate flange slowly while pushing down over shaft. Be careful not to invert or damage seals.

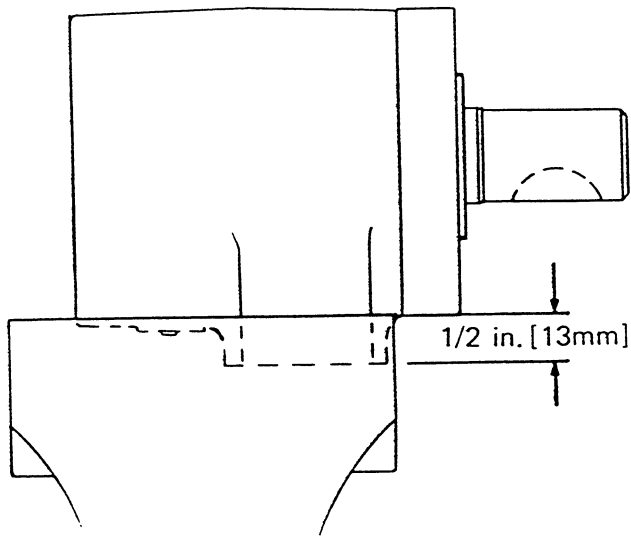

Figure 15

28 After removing bullet, clamp motor in vise as shown in Figure 15. Make sure shaft cannot fall out. Install **dry** screws and alternately torque them immediately to 250 lb-in [28 Nm]. If you use primer, allow to cure for **10 to 15 minutes**. Without primer, allow 6 hours curing time before subjecting motor to high torque reversals. On all other applications, you can run motor immediately.

If you use new screws, make sure they are the correct length: $\frac{7}{8}$ in. [22 mm] under head length. See parts list for correct part number.

Gerotor End

29 Reposition motor with gerotor end up, then clamp across ports. Do not clamp on side of housing.

Important: To aid installation of seals, apply light coat of clean petroleum jelly to seals. Do not stretch seals before installing them in groove.

30 Pour approximately 35 cc of clean hydraulic oil in output shaft cavity.

31 Install $2\frac{7}{8}$ in. [73 mm] I.D. seal in housing seal groove. Avoid twisting seal.

Timing Procedure

a. Install drive. Use felt tip marker to mark one drive tooth. Align this tooth with timing dot on shaft.

Note: If drive is not symmetrical, install larger splined end into shaft.

b. Install spacer plate.

c. Install $2\frac{7}{8}$ in. [73 mm] I.D. seal in gerotor seal groove. Carefully place gerotor on spacer plate, seal side toward spacer plate.

Standard Rotation Align any star point with tooth marked on drive. See Figure 16.

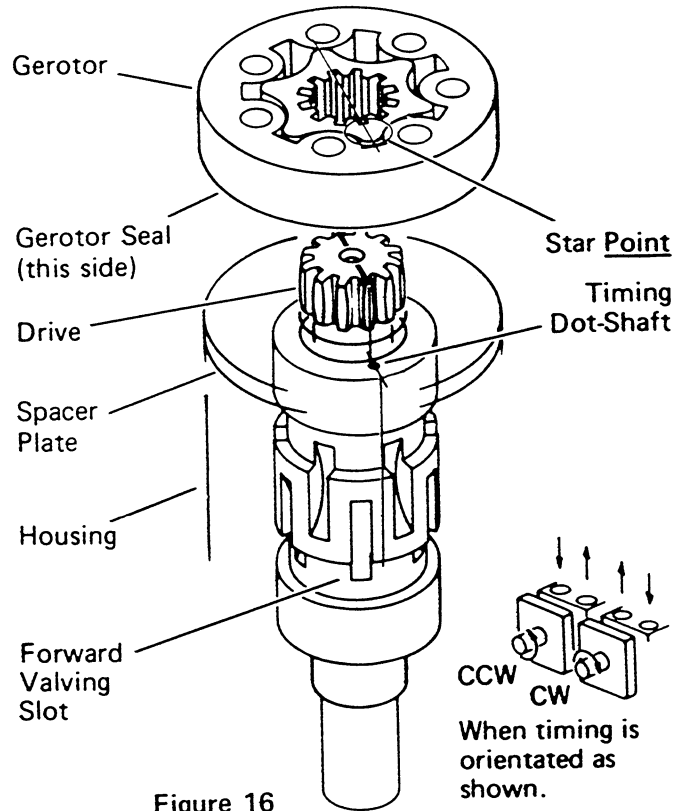

Figure 16

Reverse Rotation Align any star valley with marked tooth. See Figure 17.

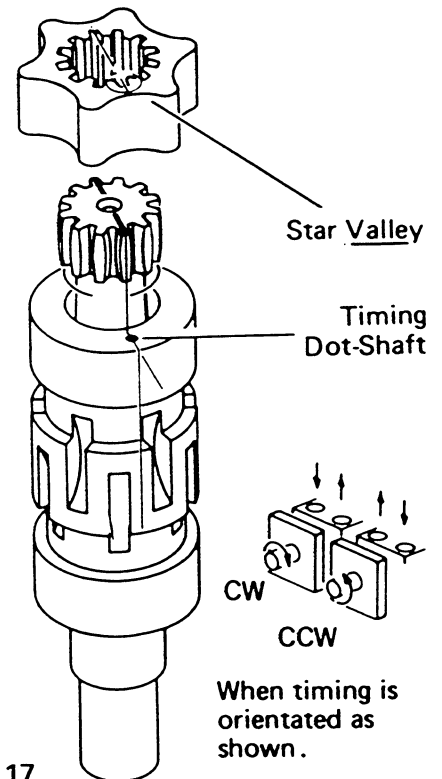

Figure 17

Reassembly Continued on Page 8

- 32 Rotate gerotor to line up bolt holes. Be careful not to disengage star from drive or disturb gerotor seal.
- 33 Install drive spacer if applicable.
- 34 Install 27/8 in. [73 mm] seal in end cap. Carefully place end cap on gerotor.

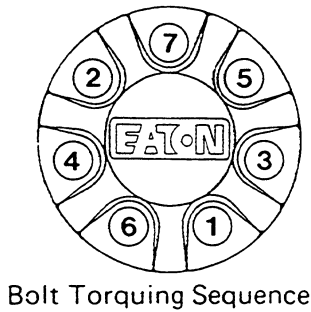
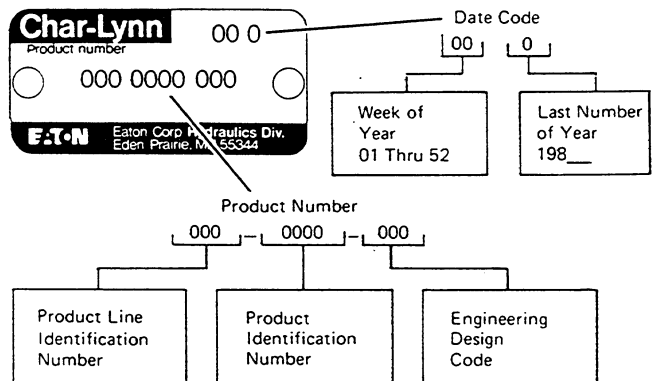
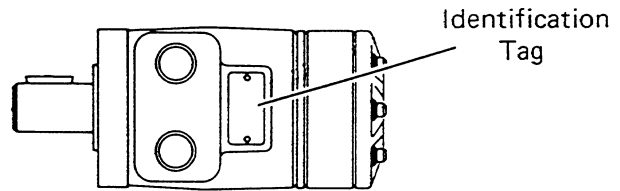

Figure 18

- 35 Install cap screws and seal washers (if applicable) in end cap. Pretighten screws to 40 lb-in [7, 4 Nm]. Make sure seals are properly seated. Then torque screws 275-300 lb-in [30-34 Nm] in sequence, as shown in Figure 18.

Each order must include the following information:

- 1 Product Number
- 2 Date Code
- 3 Part Name
- 4 Part Number
- 5 Quantity of Parts



Eaton Corporation Hydraulics Division 15151 Highway 5 Eden Prairie, MN 55344 Telephone (612) 937-9800

Eaton G.m.b.H. Hydraulics Division ☒ 100 410 · D-5620 Velbert 1 West Germany ☎ (0 20 51) 20 70



**Eaton
Hydraulics
Division**

Repair Information

Model 25300 Gear Pump - B2 Series

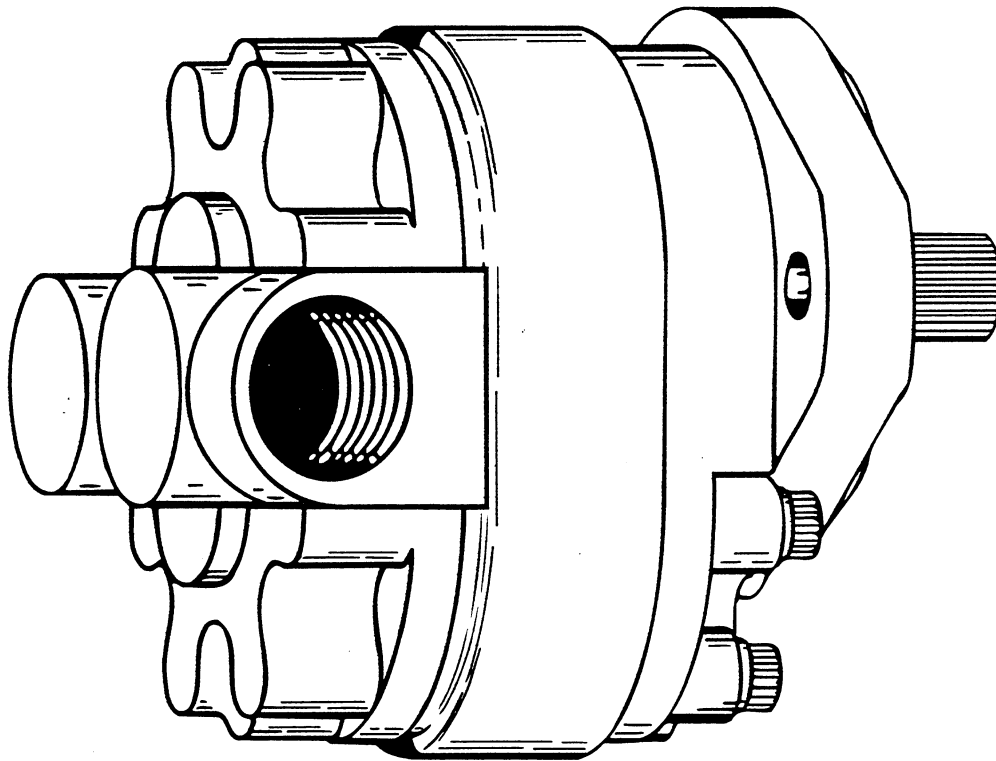

Parts Drawing-Model 25300 & 25330 Gear Pumps

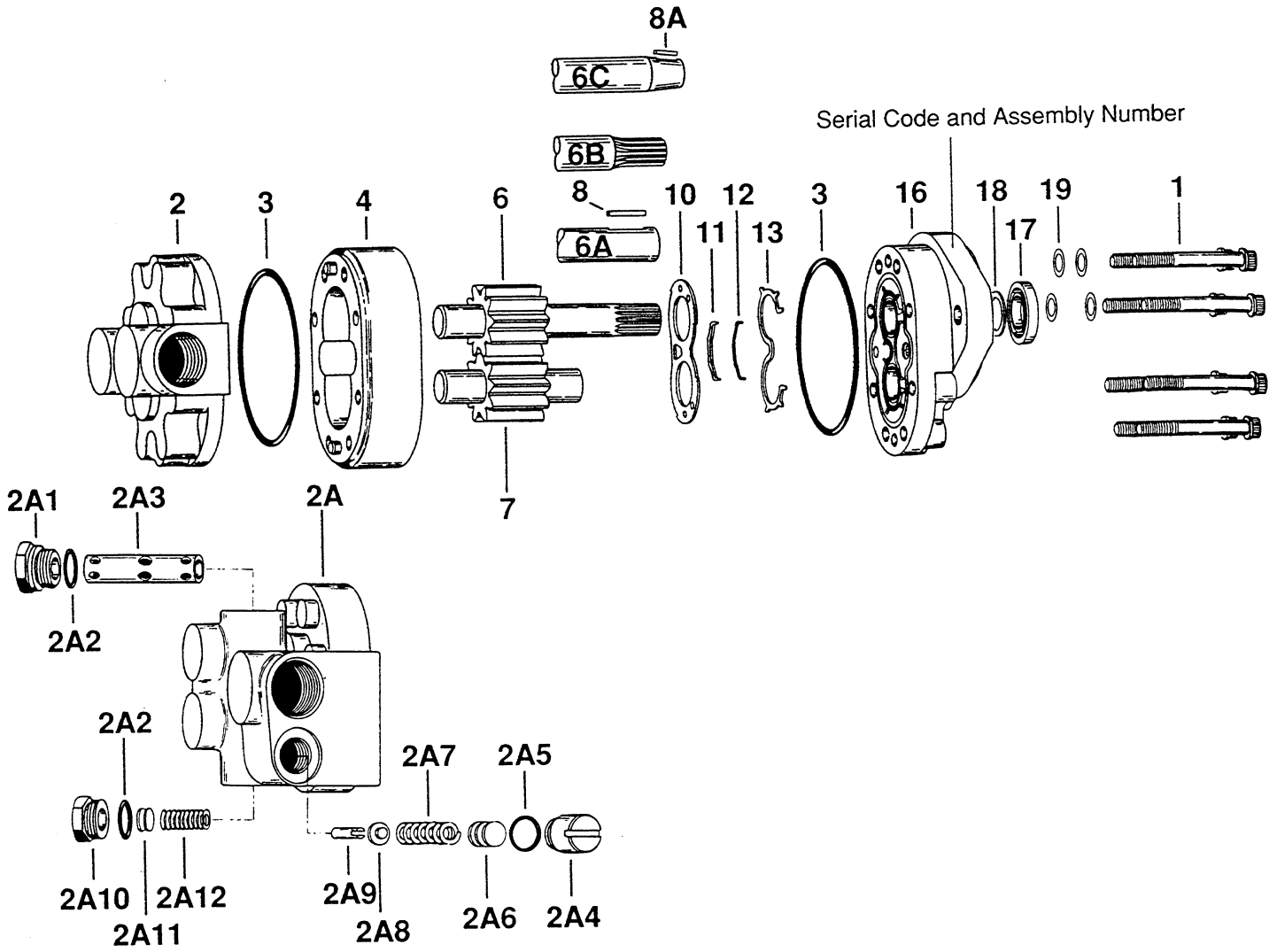

Parts List Plain and Flow Divider

Tools Required for Disassembly and Reassembly

- 3/8 in., 12 Point Socket
- Ratchet Wrench
- Torque Wrench (100 lb-ft)
- Screwdriver
- Soft Face Hammer
- Seal Driver or Simular Tool
- Light Petroleum Jelly

Item No.	Description	Qty
1	Cap screws	8
2	Backplate Assembly, Plain	1
+ 3	O-ring, 1/16 in. x 3 in. I.D. [1,59mm x 76,2mm I.D.]	2
4	Body	1
6	Drive Gear Assembly either 6,6A, 6B, or 6C	1
7	Idler Gear Assembly	1
8	Key	1
+ 10	Wear Plate	1
+ 11	Bearing Seal	1
+ 12	Molded O-ring	1
+ 13	Back-up Gasket	1
16	Front Plate	1
+ 17	Shaft Seal	1
18	Washer	1
19	Washer	4
SP	Seal Repair Kit (25300-901)	1

Item No.	Description	Qty
2A	Backplate Assembly, Flow Divider	1
2A1	Hex Plug	1
++ 2A2	O-ring, 3/32 in. x 5/8 in. I.D. [2,38mm x 15,88mm I.D.]	2
2A3	Flow Divider Spool	1
2A4	Slotted	1
++ 2A5	O-ring, 3/32 in. x 5/8 in. I.D. [2,38mm x 15,88mm I.D.]	1
2A6	Shims	As Req'd
2A7	Spring	1
2A8	Plug Seat	1
2A9	Seat	1
2A10	Hex Plug	1
2A11	Disc	As Req'd
2A12	Spring, Flow Divider	1
SF	Seal Repair Kit (25330-906)	1

- + Included in both seal repair kits
++ Included in 25330-906 kit only.

Repair Information - Model 25300

Work in a clean area, cleanliness is extremely important when repairing hydraulic pumps. Before disconnecting the lines, clean port area of pump. Disconnect hydraulic lines, removing pump assembly from vehicle and plug ports. Thoroughly clean the outside of pump. After cleaning, remove port plugs and drain oil.

Disassembly

- 1 Remove key from drive shaft if keyed drive gear assembly(6A or 6C) is used.
- 2 Put a location mark across front plate, body and backplate. This will assure proper reassembly.
- 3 Clamp pump in vise, shaft end up.
- 4 Remove cap screws(1) eight each and washer(19).
- 5 Remove pump from vise, hold pump in hands and bump shaft against wooden block to separate front plate(16) from backplate. Body (4) will remain with either front plate or backplate.
- 6 If the front plate separated first, remove wear plate (10) from body(4) gear pockets.
- 7 Remove drive gear assembly(6) and idler gear assembly(7) from body(4).
- 8 To separate body(4) from the plate it remained with, place drive gear assembly (6) in bushing and tap protruding end with plastic hammer or rawhide mallet.
- 9 Remove o-ring(3) from front plate (16) and backplate(2).
- 10 Remove back-up gasket(13) from front plate (16) by prying with a sharp tool.
- 11 Remove bearing seal(11) from front plate(16) by prying with a sharp tool.
- 12 Remove molded o-ring(12) from front plate(16).
- 13 Remove shaft seal(17)and washer(18) from front plate(16) by prying with a screw driver.
- 14 To disassemble the flow divider backplate use a slotted socket and remove relief valve plug(2A4), shims(2A6), plug seat(2A8), and seat(2A9) from backplate(2A13).Note: Do not remove internal relief valve cartridge assembly. Cartridge assembly is Locktited to a predetermined depth. Remove plug(2A1), spool(2A3), plug(2A10), shims(2A11), and spring(2A12) from backplate(2A13).

Inspect Parts for Wear

General

- 1 Clean and dry all parts.
- 2 Remove all nicks and burrs from all parts with emery cloth.

Gear Assembly Inspection

- 1 Check spline drive shaft for twisted or broken teeth or check keyed drive shaft for broken or chipped keyway.
- 2 Inspect both the drive gear and idler gear shafts at bushing points and seal area for rough surfaces and excessive wear.

- 3 Replace gear assembly if shaft measures less than .748 in. [19mm] in bushing area. (one gear assembly may be replaced separately; shafts and gears are available as assemblies only.)

- 4 Inspect gear face for scoring and excessive wear.

- 5 Replace gear assembly if gear width is below the following dimensions.Refer to chart on this page.

- 6 Assure that snap rings are in grooves on either side of drive and idler gears.

- 7 If edge of gear teeth are sharp, break edge with emery cloth.

	Model Number								
	25300	25301	25302	25303	25304	25305	25306	25307	25308
Pump Disp. cu. in./rev. [mL/rev.]	.50 [8,2]	.66 [10,8]	.84 [13,8]	1.02 [16,7]	1.20 [19,7]	1.37 [22,5]	1.54 [25,2]	1.69 [27,7]	1.87 [30,6]
Gear Width inches [millimeters]	.384 [9,75]	.510 [12,95]	.636 [16,15]	.762 [19,35]	.888 [22,56]	1.014 [25,76]	1.140 [28,96]	1.266 [32,16]	1.392 [35,36]

Front plate and Backplate Inspection

- 1 Oil groove in bushings in both front plate and backplate should be in line with dowel pin holes and 180 degrees apart. This positions the oil grooves closest to respective dowel pin holes.
- 2 Replace the backplate or front plate if I.D. of bushings exceed .755 in. [19,2mm] (Bushings are not available as separate items).
- 3 Bushings in front plate should be flush with face of front plate.
- 4 Check for scoring on face of backplate. Replace if wear exceeds .0015 in. [.038mm].

Body Inspection

- 1 Check body inside gear pockets for excessive scoring or wear.
- 2 Replace body if I.D. of gear pockets exceeds 1.713 in. [43,5mm].

General Information

It is important that the relationship of the backplate, thrust plate, body, wear plate and front plate is correct. You will note two half moon cavities in the body which must face away from the front plate. Note: The smaller half moon port cavity must be on the pressure side of the pump. Side of wear plate with mid section cut out must be on suction side of pump. Suction side of backplate is always side with larger port boss.

Reassembly

- 1 Replace the wear plate, bearing seal, molded o-ring, back-up gasket, shaft seal and o-rings as new parts.
 - 2 Install o-ring (3) in groove of front plate (16).
 - 3 Tuck back-up gasket (13) into groove in front plate (16) with open part of "V" section down of gasket.
 - 4 Place molded o-ring (12) in groove in front plate. Place bearing seal (11) over molded o-ring with groove side down.
 - 5 Apply a thin coat of petroleum jelly to both milled gear pockets of body. Slip body onto front plate with half moon port cavities in body facing away from front plate.
 - 6 Place wear plate (10) on top of back-up gasket with bronze face up. The side with the mid section cut away must be on suction side of pump.
 - 7 Dip gear assemblies into oil and slip into front plate bushings.
 - 8 Install o-ring (3) in groove of backplate (2).
 - 9 Slide backplate (2) over gear shafts until dowel pins are engaged.
 - 10 Secure with cap screws (1) and new washers(19). Tighten cap screws evenly in a crisscross pattern to 25/28 ft. lbs. torque.
 - 11 Place washer (18) over drive shaft into housing. Liberally oil shaft seal(17) and install over drive shaft, carefully so that rubber sealing lips are not cut.
 - 12 Place 1-5/16" O.D. sleeve over shaft and press in shaft seal (17) until flush with front surface of front plate.
 - 13 Install key on keyed shaft.
- Note: Refer to Trouble Shooting and Start-up Procedure .

Parts Drawing-Model 25380 Double Gear

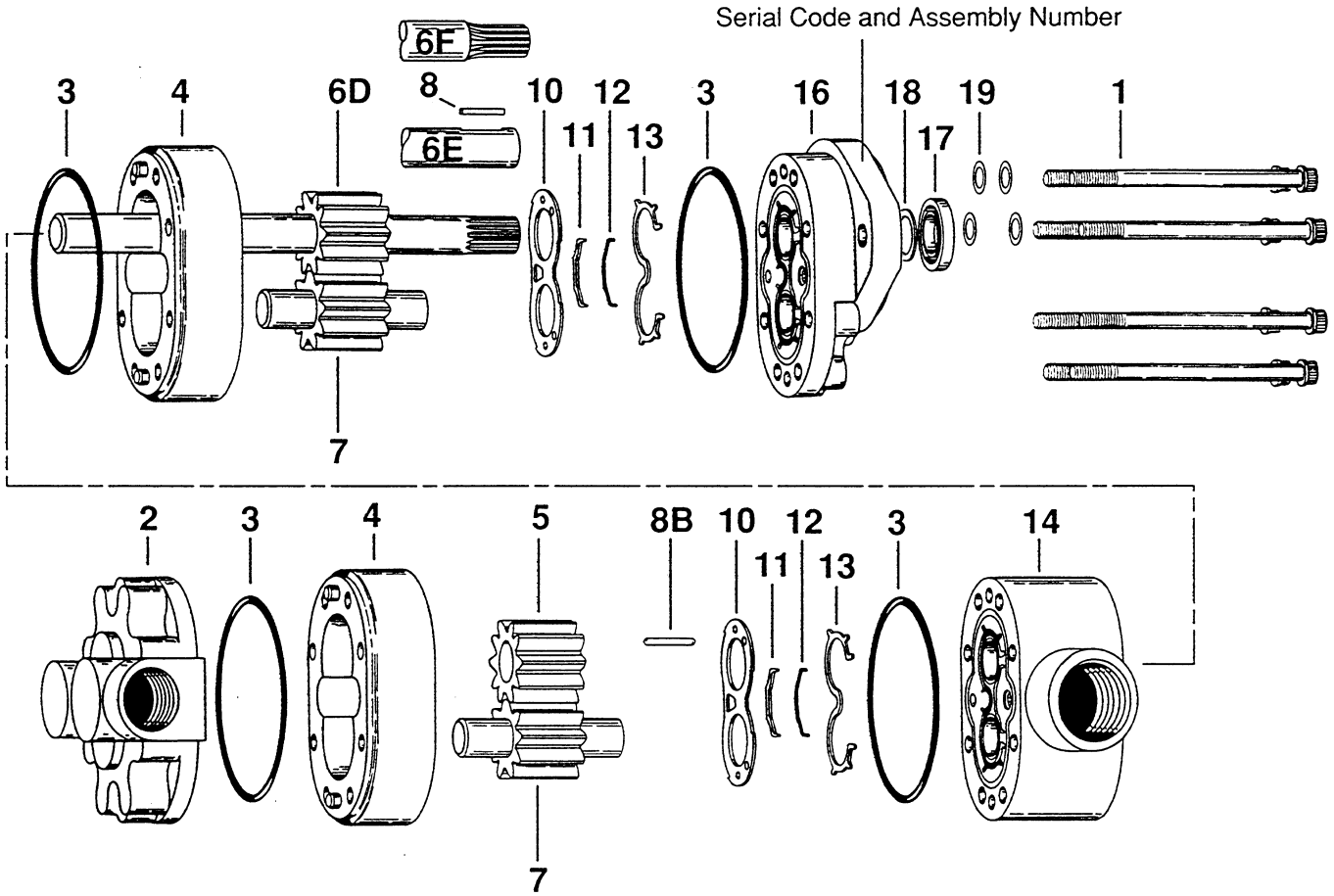

Parts List Model 25380 Double Gear Pump

Tools Required for Disassembly and Reassembly

- 3/8 in., 12 Point Socket
- Ratchet Wrench
- Torque Wrench (100 lb-ft)
- Screwdriver
- Soft Face Hammer
- Seal Driver or Simular Tool
- Light Petroleum Jelly

Item No.	Description	Qty
1	Cap screws	8
2	Backplate Assembly, Plain or Flow Divider	1
+	3 O-ring, 1/16 in. x 3 in. I.D. [1,59mm x 76,2mm I.D.]	2
4	Body	2
5	Slip Fit Gear	1
6	Drive Gear Assembly either 6D, 6E, or 6F	1
7	Idler Gear Assembly	2
8	Key	1
8B	Rear Key	1
+	10 Wear Plate	2
+	11 Bearing Seal	2
+	12 Molded O-ring	2
+	13 Back-up Gasket	2
14	Adapter Plate	1
16	Front Plate	1
+	17 Shaft Seal	1
18	Washer	1
+	19 Washer	4
S	Seal Repair Kit	1

+ Included in both seal repair kits

Repair Information - Model 25380

Work in a clean area, cleanliness is extremely important when repairing hydraulic pumps. Before disconnecting the lines, clean port area of pump. Disconnect hydraulic lines, removing pump assembly from vehicle and plug ports. Thoroughly clean the outside of pump. After cleaning then remove port plugs and drain oil.

Disassembly

- 1 Remove key from drive shaft if keyed drive- gear assembly(6E) is used.
- 2 Put a location mark across front plate, body and backplate. This will assure proper reassembly.
- 3 Clamp pump in vise, shaft end up.
- 4 Remove cap screws(1) eight each and washers(19).
- 5 Remove pump from vise, hold pump in hands and bump shaft against wooden block to separate front pump sections. Front body (4) will remain with either front plate(16) or adapter plate(14).
- 6 Place front idler gear (7) into gear pocket and tap with soft face hammer till the front body separates. Now remove idler gear from front plate or adapter plate.
- 7 Remove backplate (7) from body (4) by tapping on backplate with plastic hammer or rawhide mallet.
- 8 Remove rear idler gear (7), slip fit gear (5) and key (8B).
- 9 Remove drive gear assembly from adapter plate.
- 10 Place rear idler gear assembly back into gear pocket and tap protruding end with soft face hammer to remove rear body (4) from plate it remained with.
- 11 Remove front wear plate (10) from front plate (16) and remove rear wear plate (10) from adapter plate (14).
- 12 Remove o-rings (3) from front plate (16), adapter plate (14), and backplate (2).
- 13 Remove back-up gasket (13), bearing seal (11) and molded o-ring (12) from front plate (16) and adapter plate (14) by prying out with a sharp tool.
- 14 Remove shaft seal(17) and washer(18) from front plate(16) by prying with a screw driver.

Inspect Parts for Wear

General

- 1 Clean and dry all parts.
- 2 Remove nicks and burrs from all parts with emery cloth.

Gear Assembly Inspection

- 1 Check spline drive shaft for twisted or broken teeth or check keyed drive shaft for broken or chipped keyway. Also check for broken keyway, on drive shaft, that drives the slip fit gear of the rear pump.
- 2 Inspect both the drive gear and idler gear shafts at bushing points and seal area for rough surfaces and excessive wear.

- 3 Replace gear assembly if shaft measures less than .748 in. [19mm] in bushing area. (one gear assembly may be replaced separately; shafts and gears are available as assemblies only. The slip fit gear is available separately).
- 4 Inspect gear face for scoring and excessive wear.
- 5 Replace gear assembly if gear width is below the following dimensions. Refer to chart on this page.
- 6 Assure that snap rings are in grooves on either side of drive and idler gears.
- 7 If edge of gear teeth are sharp, break edge with emery cloth.

	Model Number								
	25300	25301	25302	25303	25304	25305	25306	25307	25308
Pump Disp. cu. in./rev. [mL/rev.]	.50 [8,2]	.66 [10,8]	.84 [13,8]	1.02 [16,7]	1.20 [19,7]	1.37 [22,5]	1.54 [25,2]	1.69 [27,7]	1.87 [30,6]
Gear Width inches [millimeters]	.384 [9,75]	.510 [12,95]	.636 [16,15]	.762 [19,35]	.888 [22,56]	1.014 [25,76]	1.140 [28,96]	1.266 [32,16]	1.392 [35,36]

Front Plate, Backplate and Adapter Plate Inspection

- 1 Oil groove in bushings in front plate, backplate and adapter plate should be in line with dowel pin holes and 180 degrees apart. This positions the oil grooves closest to respective dowel pin holes.
- 2 Replace the backplate, front plate or adapter plate if I.D. of bushings exceed .755 in. [19,2mm] (Bushings are not available as separate items).
- 3 Bushings in front plate and back-up gasket side of adapter plate should be flush with face of plate.
- 4 Check for scoring on face of backplate or adapter plate. Replace if wear exceeds .0015 in. [.038mm].

General Information

It is important that the relationship of the backplate, thrust plate, body, wear plate and front plate is correct. You will note two half moon cavities in the body which must face away from the front plate or adapter plate. Note: The smaller half moon port cavity must be on the pressure side of the pump. The side of thrust plate and wear plate with mid section cut out must be on suction side of pump. Suction side of backplate or adapter plate is always the side with larger port boss.

Reassembly

- 1 Replace the wear plates, bearing seals, molded o-rings, back-up gaskets, shaft seal and o-rings as new parts.
 - 2 Install o-rings (3) in groove of front plate (16), adapter plate (14), and backplate (2) with a small amount of petroleum jelly to hold in place.
 - 3 Tuck back-up gasket (13) in front plate (16) and adapter plate (14) with open part of "V" section down.
 - 4 Place molded o-ring (12) in groove in front plate and adapter plate. Place bearing seal (11) over molded o-ring, groove side down.
 - 5 Apply a thin coat of petroleum jelly to both milled gear pockets of body. Slip body onto front plate with half moon port cavities in body facing away from front plate.
- Note:** The small half moon port cavity must be on the pressure side of pump.
- 6 Place wear plate (10) on top of back-up gasket with bronze face up. The side with the mid section cut away must be on suction side of pump.
 - 7 Dip drive gear assembly and idler gear assembly into oil. Slip both gear assemblies into gear pocket of body and into front plate bushings.

Body Inspection

- 1 Check body inside gear pockets for excessive scoring or wear.
- 2 Replace body if I.D. of gear pockets exceeds 1.713 in. [43,5mm].

- 8 Install adapter plate (14) in place on front body (4). Check positioning mark on all sections of pump.
 - 9 Install rear body (4) onto adapter plate (14) and install wear plate (10).
 - 10 Install key (8B) in slot of drive gear shaft assembly. Dip slip fit gear (5) in oil and slip on shaft and into gear pocket of rear body. Check key for proper location.
 - 11 Dip rear idler gear (7) in oil and install in gear pocket of rear body (4).
 - 12 Position backplate (2) over shafts until dowel pins in body are engaged.
 - 13 Secure with cap screws (1) and new washers(19). Tighten cap screws evenly in a crisscross pattern to 25/28 ft. lbs. torque.
- 11 Place washer (18) over drive shaft into housing. Liberally oil shaft seal(17) and install over drive shaft, carefully so that rubber sealing lips are not cut.
 - 12 Place 1-5/16" O.D. sleeve over shaft and press in shaft seal (17) until flush with front surface of front plate.
 - 13 Install key on keyed shaft.

Note: Refer to Trouble Shooting and Start-up Procedure

Placing Pump Back Into Service

1 If shop test stand is available, the following procedure for testing rebuilt pumps is recommended:

- A** Mount pump on test stand making sure that the proper level of clean oil is available in the reservoir. Check suction line for leaks and obstructions.
- B** Start pump and run for three minutes at zero pressure.
- C** Intermittently load pump to 500 P.S. I. for three minutes.
- D** Intermittently load pump to 1000 P.S.. for three minutes.
- E** Intermittently load pump to 2000 P.S. I. for three minutes.
- F** Remove pump from test stand and check for freeness of drive shaft. Check for leaks.

2 If shop test stand is not available, the following procedure for testing rebuilt pumps is recommended:

- A** Mount pump on equipment and run pump at 1 /2 engine speed at zero pressure.
- B** By operating control valve build pressure intermittently for three minutes.
- C** Increase engine speed to full throttle and build pressure intermittently for three minutes.
- D** Idle engine and check for leaks.

Single or Double Pump Trouble Shooting

Problem	Possible Cause	Correction
1. Noisy pump caused by cavitation.	<ul style="list-style-type: none"> a. Oil too heavy. b. Oil filter plugged. c. Suction line plugged or too small. 	<ul style="list-style-type: none"> a. Change to proper viscosity. b. Clean filters. c. Clean line and check for size.
2. Oil heating	<ul style="list-style-type: none"> a. Oil supply low. b. Contaminated oil. c. Setting of relief valve too high or too low d. Oil in system too light. 	<ul style="list-style-type: none"> a. Fill reservoir. b. Drain reservoir and refill with clean oil. c. Set to correct pressure. d. Drain reservoir and refill with proper viscosity oil.
3. Shaft seal leakage	<ul style="list-style-type: none"> a. Worn shaft seal. b. Worn shaft in seal area c. Broken bearing seal or back-up gasket d. Bushings out of position. e. Excessive internal wear. 	<ul style="list-style-type: none"> a. Replace shaft seal. b. Replace drive shaft c. Replacing the shaft and shaft seal does not stop seal leakage, the pump should be disassembled and checked for items 3, c & d. d. Disassemble pump and replace front plate. e. Disassemble pump inspect parts and replace as needed.
4. Foaming oil	<ul style="list-style-type: none"> a. Low oil level b. Air leaking into suction line c. Wrong kind of oil. 	<ul style="list-style-type: none"> a. Fill reservoir. b. Tighten fittings. c. Drain and fill reservoir with non-foaming oil.

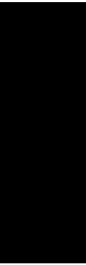

Identification Numbers

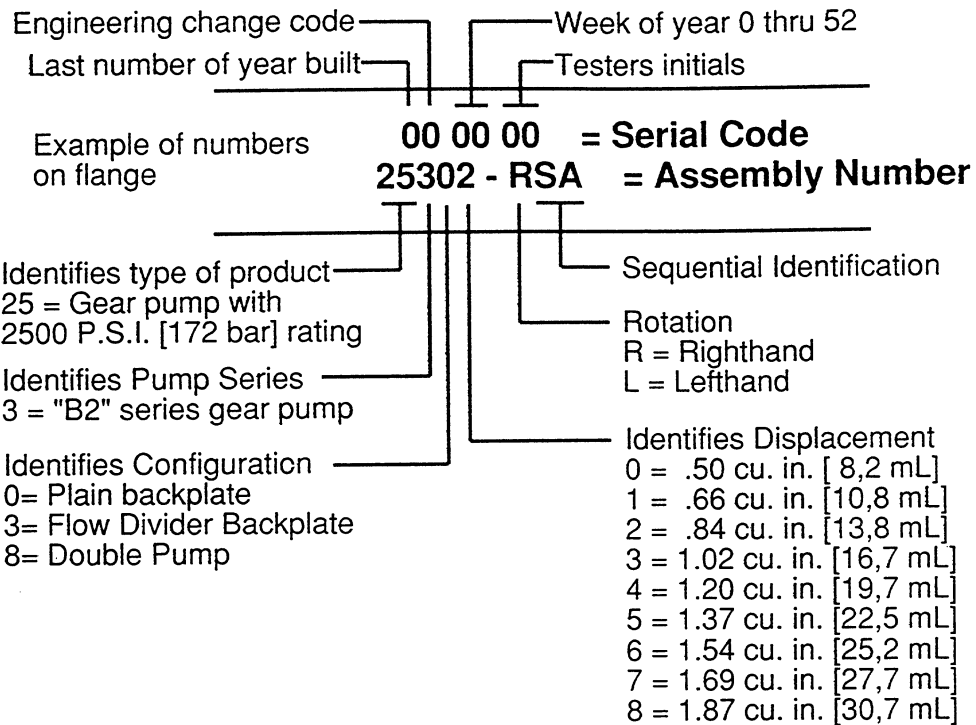

Eaton Corporation **Hydraulics Division**, 15151 Highway 5, Eden Prairie, MN 55344 Telephone (612) 937-9800

Eaton G.m.b.H. **Hydraulics Division** ☒ 100 410 • D-5620 Velbert 1 West Germany ☎ 49-2051-20745



Eaton[®]
Gear Pumps

No. 6-628
March, 1993

EATON

Parts Information

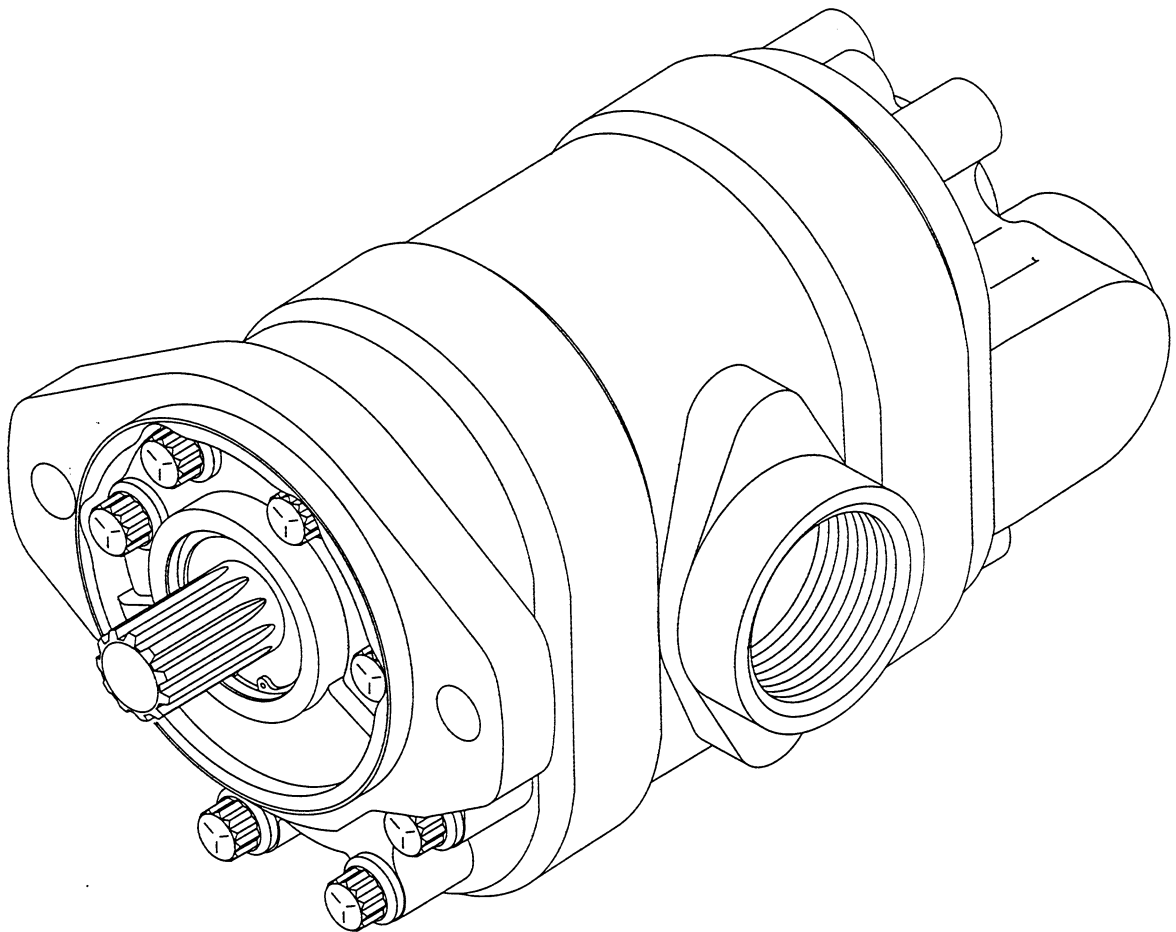

Model 25380 Multiple Gear Pumps
B2 Series

Pump Parts Drawing

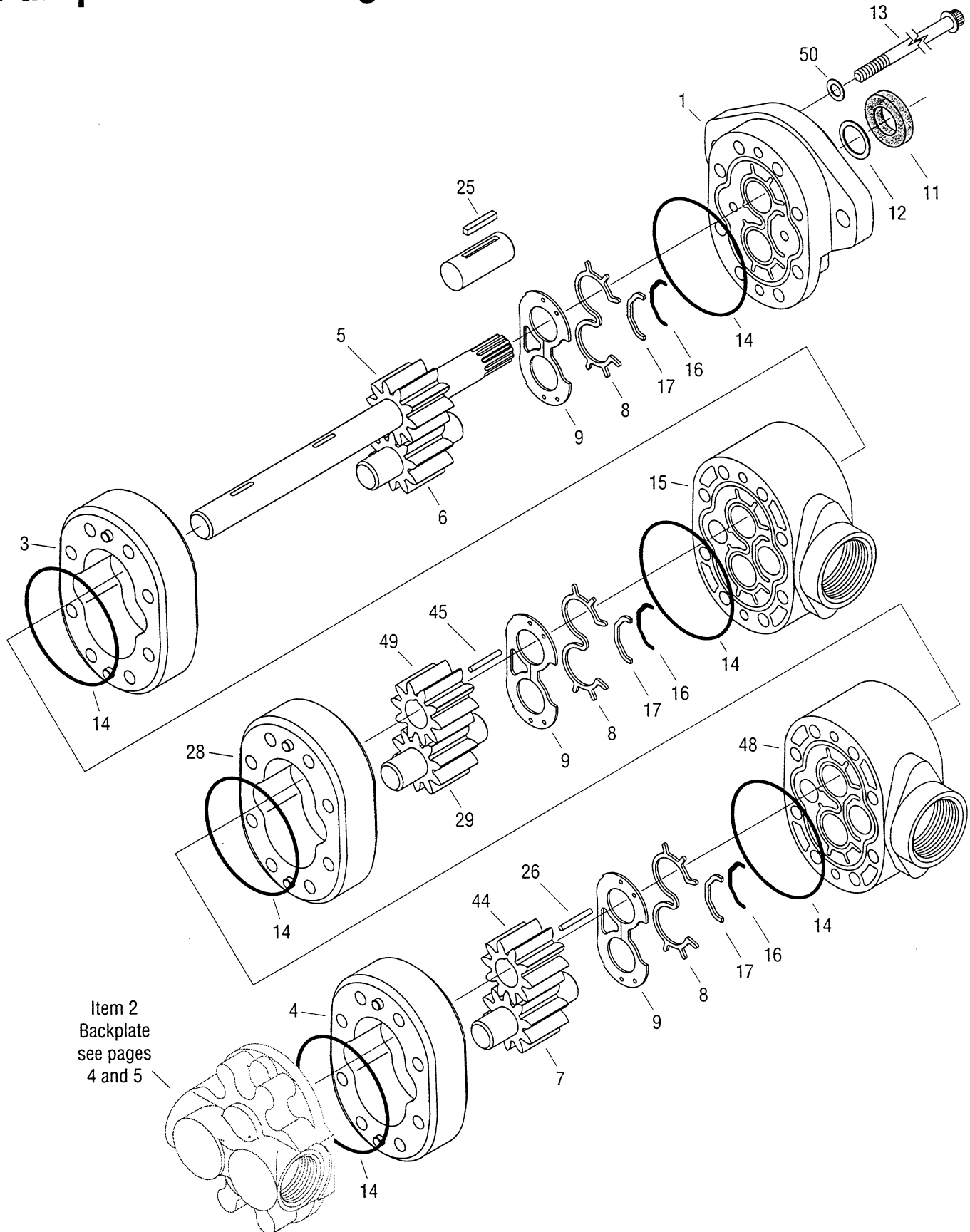

Item 2
Backplate
see pages
4 and 5

Pump Parts List

Item No.	Part Number	Description	Qty.
1		Frontplate Assembly	1
	25300-526	Left-Hand Rotation	
	25300-523	Right-Hand Rotation	
2		Backplate (see pages 4 and 5)	1
3	Δ	Body Assembly – Front	1
4	Δ	Body Assembly – Rear	1
5	†	Drive Gear Assembly	1
6	Δ	Idler Gear Assembly – Front	1
7	Δ	Idler Gear Assembly – Rear	1
~	8 25300-647	Backup Gasket	A/R
~	9 25300-600	Wear Plate	A/R
~	11 15147-281	Shaft Seal	1
~	12 16048-27	Washer	1
	13 †	Cap Screw	8
~	14 16007-513	O-ring	A/R
	15 25380-469	Adaptor Plate– Front	1
~	16 25300-601	Molded O-ring	A/R
~	17 25300-603	Bearing Seal	A/R
	25 15511-568	Key for Straight Shaft	1
	26 Δ	Key – Rear Gear	1
	28 Δ	Body Assembly – Center	A/R
	29 Δ	Idler Gear Assembly – Center	A/R
	44 Δ	Gear – Rear	1
	45 Δ	Key – Center Gear	A/R
	48 25380-469	Adaptor Plate – Rear	A/R
	49 Δ	Gear – Center	A/R
	50 21006-19	Copper Washer	4
	25380-930	Seal Kit for Double Pump	
	25380-950	Seal Kit for Triple Pump	

- Δ – See table, below, for specific part number
- † – See tables on pages 6 and 7 for specific part number
- ~ – Parts contained in seal kits
- A/R – As Required

Displacement cm ³ /r [in ³ /r]	Item No. 3, 4 and 28 Body Assembly	Item No. 6, 7 and 29 Idler Gear	Item No. 44 and 49 Gear	Item No. 26 and 45 Key
8.2 [.50]	25300-252	25300-302	25380-250	16243-105
10.8 [.66]	25301-255	25301-303	25381-251	16243-107
13.8 [.84]	25302-255	25302-303	25382-251	16243-109
16.7 [1.02]	25303-255	25303-303	25383-251	16243-111
19.7 [1.20]	25304-258	25304-307	25384-253	16243-113
22.5 [1.37]	25305-255	25305-303	25385-250	16243-114
25.2 [1.54]	25306-255	25306-303	25386-251	16243-115
27.7 [1.69]	25307-254	25307-314	25387-252	16243-117
30.6 [1.87]	25308-259	25308-306	25388-251	16243-120

Backplate Drawings

Plain Backplate

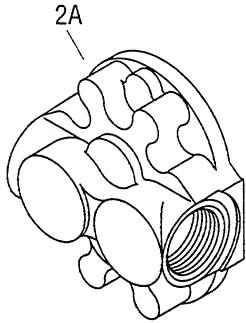

Flow Divider Backplate

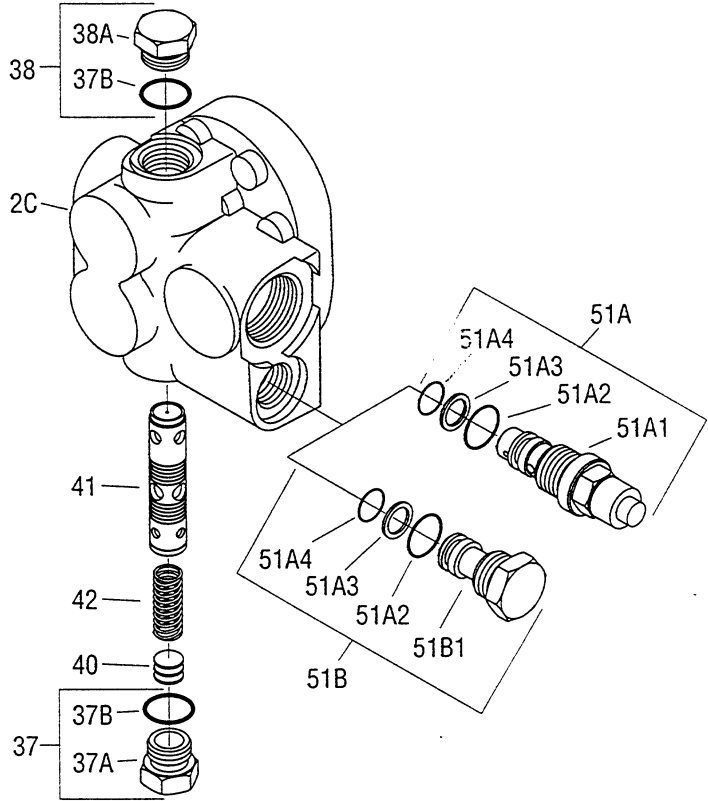

Relief Valve Backplate

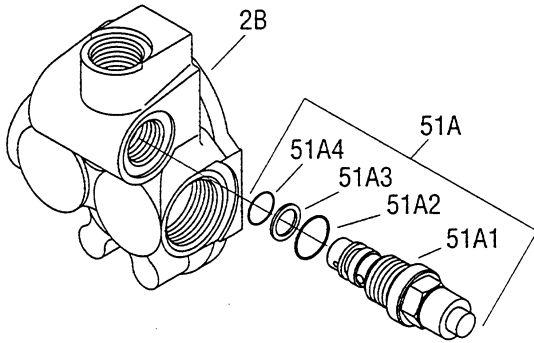

Tandem Backplate

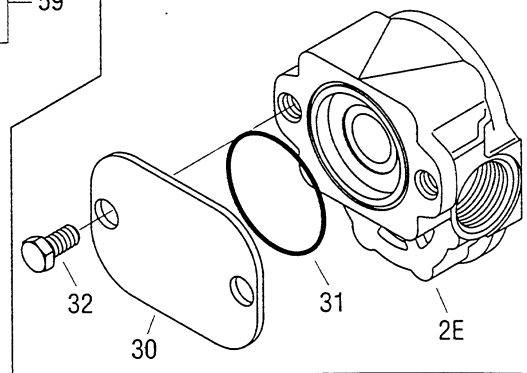

Tandem Flow Divider Backplate

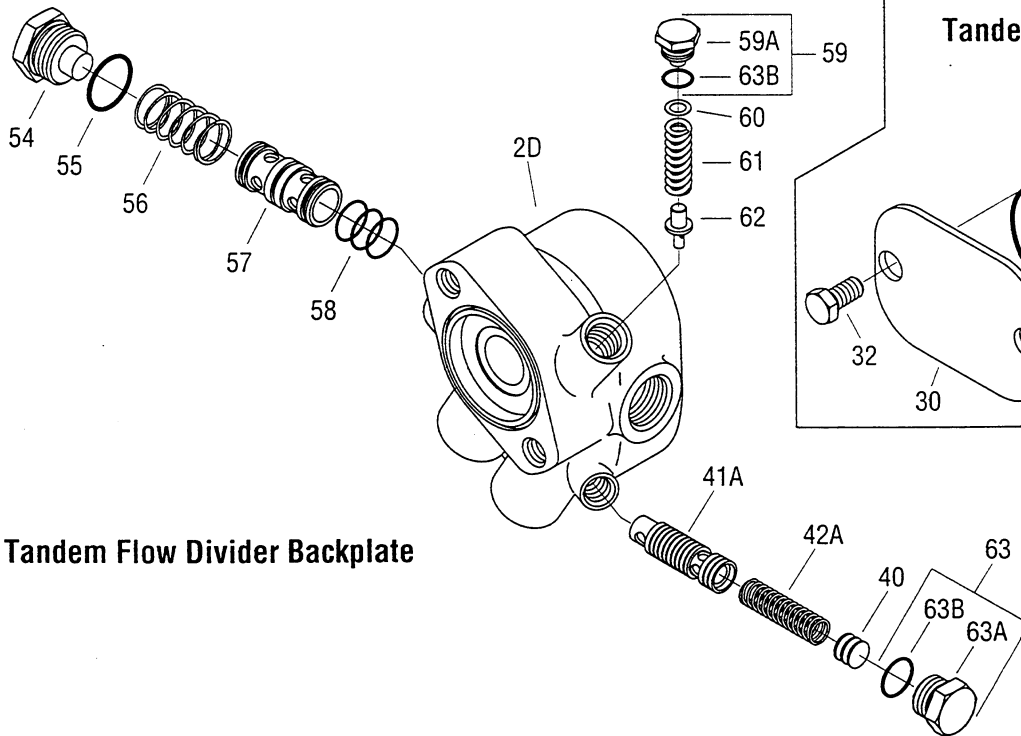

Backplate Parts List

Item No.	Part Number	Description	Qty.
2A		Plain Backplate	1
	25300 - 38	Side Ports – 1 5/16-12 Suction, 7/8-14 Pressure	
	25300 - 39	Rear Ports – 1 5/16-12 Suction, 7/8-14 Pressure	
	25300 - 41	Side Ports – 1 1/16-12 Suction, 7/8-14 Pressure	
2B		Relief Valve Backplate	1
	25310 - 27	Side Ports – 1 1/16-12 Suction, 7/8-14 Pressure, 7/8-14 Drain	
	25310 - 28	Side Ports – 1 1/16-12 Suction, 7/8-14 Pressure, Internal Drain	
	25310 - 30	Side Ports – No Suction, 7/8-14 Pressure, Internal Drain	
2C		Flow Divider Backplate	1
	25330 - 22	Side Ports – 1 5/16-12 Suction, 3/4-16 Priority, 7/8-14 Secondary	
	25330 - 23	Rear Ports – 1 5/16-12 Suction, 3/4-16 Priority, 7/8-14 Secondary	
2D		Tandem Flow Divider Backplate	1
	X25340 - 10	Side Ports – 1 1/16-12 Suction, 3/4-16 Priority, 7/8-14 Secondary	
2E		Tandem Backplate	1
	X25340 - 11	Side Ports – 1 1/16-12 Suction, 7/8-14 Pressure	
	25380 - 38	Side Port – No Suction, 7/8-14 Pressure	
30	25340 - 601	Tandem Cover Plate	1
31	16015 - 38	O-ring	1
32	16032 - 606	Cap Screw	2
37	15440 - 303	Plug/O-ring Assembly	1
37A	NSS	Plug	1
37B	16003 - 12 - 90	O-ring	2
38	16224 - 05	Plug/O-ring Assembly	1
38A	NSS	Plug	1
40	15511 - 141	Shim (.0239 inch thick)	A/R
41	Δ	Flow Divider Spool	1
41A	24330 - 604	Spool for Tandem Flow Divider Backplate	
42	17046 - 20	Spring	1
42A	15511 - 142	Spring for Tandem Flow Divider Backplate	1
51A	Δ	Relief Valve Assembly	1
51A1	NSS	Relief Valve	1
51A2	16015 - 17	O-ring	1
51A3	16235 - 111	Backup Ring	1
51A4	16003 - 11	O-ring	1
51B	33100 - 301	Plug Assembly	1
51B1	NSS	Plug	1
54	15511 - 430	Plug	1
55	16015 - 18 - 90	O-ring	1
56	15511 - 473	Spring	1
57	15511 - 110	Sleeve	1
58	16015 - 5 - 90	O-ring	3
59	16225 - 05	Plug/O-ring Assembly	1
59A	NSS	Plug	1
60	16048 - 35	Shim Washer (.010 inch thick)	A/R
61	32015 - 24	Relief Valve Spring	1
62	32015 - 51	Poppet	1
63	16224 - 09	Plug/O-ring Assembly	1
63A	NSS	Plug	1
63B	16003 - 12 - 90	O-ring	2

Δ – See tables on pages 6 and 7 for specific part numbers
 NSS – Not Sold Separately
 A/R – As Required

Parts List

Item No. 5 – Drive Gear Assembly

Part Number	Front Displacement cm ³ /r [in ³ /r]	Center Displacement cm ³ /r [in ³ /r]	Rear Displacement cm ³ /r [in ³ /r]	Shaft End
25380 - 313	8.2 [.50]		8.2 [.50]	5/8 inch 9 Tooth spline
25380 - 324	8.2 [.50]		8.2 [.50]	3/4 inch 11 Tooth Spline
25381 - 301	10.8 [.66]		8.2 [.50]	5/8 inch 9 Tooth Spline
25381 - 305	10.8 [.66]		10.8 [.66]	3/4 inch 11 Tooth Spline
25381 - 317	10.8 [.66]		16.7 [1.02]	5/8 inch 9 Tooth Spline
25381 - 319	10.8 [.66]	10.8 [.66]	10.8 [.66]	3/4 inch 11 Tooth Spline
25381 - 321	10.8 [.66]		16.7 [1.02]	3/4 inch 11 Tooth Spline
25381 - 325	10.8 [.66]	10.8 [.66]	8.2 [.50]	3/4 inch 11 Tooth Spline
25382 - 305	13.8 [.84]		13.8 [.84]	5/8 inch 9 Tooth Spline
25382 - 327	13.8 [.84]	13.8 [.84]	13.8 [.84]	3/4 inch 11 Tooth Spline
25383 - 323	16.7 [1.02]		8.2 [.50]	5/8 inch 9 Tooth Spline
25384 - 309	19.7 [1.20]		19.7 [1.20]	3/4 inch 11 Tooth Spline
25384 - 311	19.7 [1.20]		13.8 [.84]	5/8 inch 9 Tooth Spline
25384 - 319	19.7 [1.20]		10.8 [.66]	5/8 inch 9 Tooth Spline
25384 - 325	19.7 [1.20]		8.2 [.50]	3/4 inch 11 Tooth Spline
25385 - 319	22.5 [1.37]		19.7 [1.20]	3/4 inch 11 Tooth Spline
25385 - 341	22.5 [1.37]		10.8 [.66]	3/4 inch Straight Keyed
25386 - 307	25.2 [1.54]		16.7 [1.02]	3/4 inch 11 Tooth Spline
25386 - 315	25.2 [1.54]		19.7 [1.20]	3/4 inch 11 Tooth Spline
25387 - 305	27.7 [1.69]		16.7 [1.02]	5/8 inch 9 Tooth Spline
25387 - 307	27.7 [1.69]		10.8 [.66]	5/8 inch 9 Tooth Spline
25387 - 313	27.7 [1.69]		10.8 [.66]	3/4 inch 11 Tooth Spline
25388 - 303	30.6 [1.87]		30.6 [1.87]	5/8 inch 9 Tooth Spline
25388 - 309	30.6 [1.87]		13.8 [.84]	5/8 inch 9 Tooth Spline
25388 - 311	30.6 [1.87]		16.7 [1.02]	3/4 inch 11 Tooth Spline

Item No. 51A – Relief Valve Assembly

Part Number	Pressure Setting (bar [PSI])
	34.5 [500]
	51.7 [750]
32080 - CA	68.9 [1000]
32080 - EA	86.2 [1250]
32080 - GA	103.4 [1500]
32080 - JA	120.6 [1750]
32080 - LA	137.9 [2000]
32080 - NA	155.1 [2250]
32080 - QA	172.4 [2500]

Parts List

Item No. 41 – Flow Divider Spool

Part Number	Flow Setting (LPM [GPM])
	3.8 [1.00]
25330 - 612	5.7 [1.50]
25330 - 617	7.6 [2.00]
	9.5 [2.50]
25330 - 600	11.4 [3.00]
	13.3 [3.50]
25330 - 603	15.1 [4.00]
25330 - 608	17.0 [4.50]
25330 - 608	18.9 [5.00]
25330 - 605	20.8 [5.50]
25330 - 601	22.7 [6.00]

Item No. 13 – Cap Screw

Part Number	Dimension L (mm [in.])
16119 - 544	114 [4.50]
16119 - 546	121 [4.75]
16119 - 550	127 [5.00]
16119 - 552	133 [5.25]
16119 - 554	140 [5.50]
16119 - 556	146 [5.75]
16119 - 560	152 [6.00]
16119 - 562	159 [6.25]
16119 - 564	165 [6.50]
16119 - 572	184 [7.25]
16119 - 574	191 [7.50]
16119 - 580	203 [8.00]

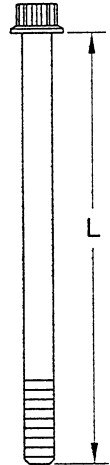

Pump Identification

Numbers Stamped on Mounting Flange

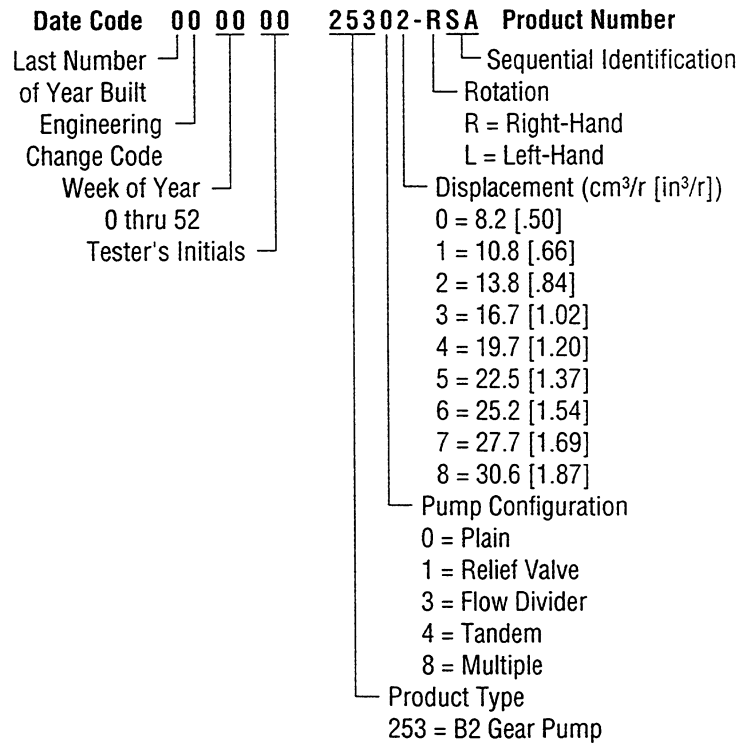

Eaton Corporation
Hydraulics Division
15151 Hwy. 5
Eden Prairie, MN 55344
Telephone 612/937-9800
Fax 612/937-7130

Eaton G.m.b.H.
Hydraulics Division
✉ 100 410 • D-5620 Velbert 1 Germany
☎ 49-2051-2070
Teletex 205 119 EATVEL
Telefax 49-2051-207200



Eaton®
Medium Duty Piston Pump

No. 7-622



Repair Information

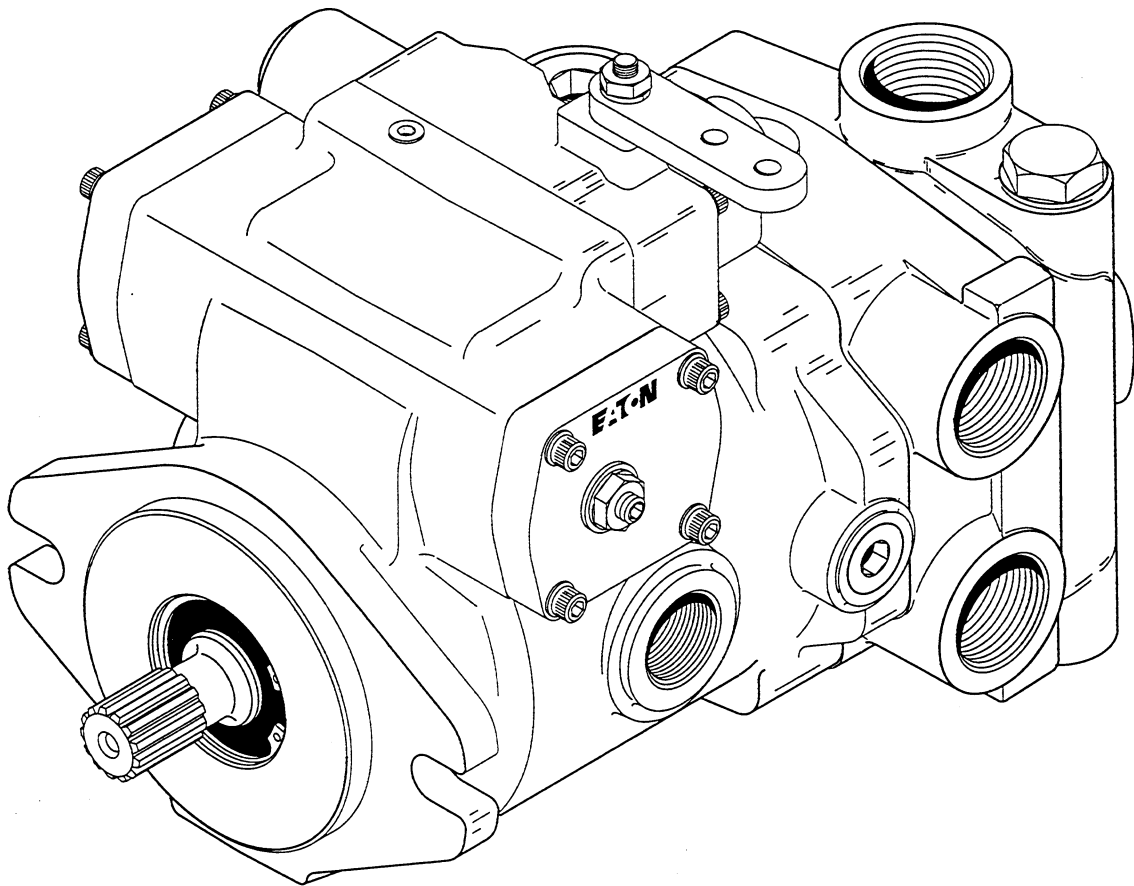

Model 72400
Servo Controlled Piston Pump

Introduction

Table of Contents

Introduction	2
Identification	3
Required Tools	3
Exploded View Drawing	4 & 5
Parts List	6 & 7
Disassembly and Inspection	8
Reassembly	9
Appendix A:	11
Appendix B:	12 - 15
Appendix C:	16
Fault-Logic Trouble Shooting	17 - 21
Start-up Procedure	22

Introduction

This manual provides service information for the Eaton Model 72400 Servo Controlled Piston Pumps. Step by step instructions for the complete disassembly, inspection, and reassembly of the pump are given. The following recommendations should be followed to insure successful repairs.

- Remove the pump from the vehicle.
- Cleanliness is extremely important.
- Clean the port areas thoroughly before disconnecting the hydraulic lines.
- Plug the pump ports and cover the open hydraulic lines immediately after they're disconnected.
- Drain the oil and clean the exterior of the pump before making repairs.
- Wash all metal parts in clean solvent.
- Use compressed air to dry the parts. Do not wipe them dry with paper towels or cloth.
- The compressed air should be filtered and moisture free.
- Always use new seals when reassembling hydraulic pumps.
- For replacement parts and ordering information refer to parts list 6-633.
- Lubricate the new rubber seals with a petroleum jelly (vaseline) before installation.
- Torque all bolts over gasketed joints, then repeat the torquing sequence to make-up for gasket compression.
- Verifying the accuracy of pump repairs on an authorized test stand is essential.

Identification and Tools Required

Identification Numbers

Stamped on each unit.

- A - Product Number Description
72400 = Single Piston Pump
78461 = Tandem Piston Pump
78462 = Single or Tandem
Piston Pump with Gear Pump
- B - Sequential Numbering
- C - Design Code Number

Single Pump - Product Number

72400 - 001 - 03

A
B
C

Tandem Pumps - Product Number

78461 - 001 - 03

A
B
C

Serial Number Code:

B 93 01 31 JB

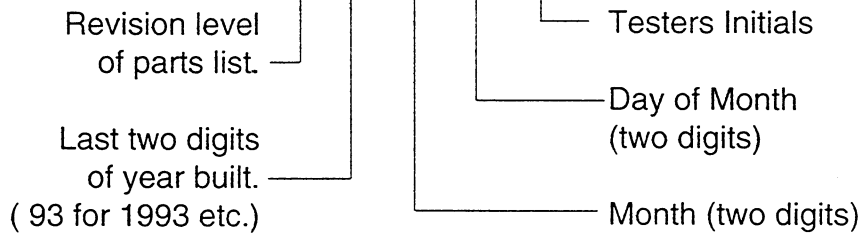

Required Tools

- 9/16 in. Hex Key (Allen)
- 5/32 in. Hex Key (Allen)
- 5/16 in. Hex Key (Allen)
- 3/32 in. Hex Key (Allen)
- 5/64 in. Hex Key (Allen)
- 7/16 in. End Wrench
- 9/16 in. End Wrench
- 3/4 in. End Wrench
- 1 in. End Wrench
- 9/16 in. Socket
- 3/4 in. Socket
- 7/16 in. Socket
- Internal Retaining Ring Pliers (straight .070 tip)
- Internal Retaining Ring Pliers (straight .090 tip)
- External Retaining Ring Pliers (straight .090 tip)
- 9/32 in. retaining E-ring, applicator
- 1/2 in. retaining E-ring, applicator
- O-ring Pick
- Torque Wrench (135.6 N•m [100 lbf•ft] capacity)
- Hammer (soft face)
- Light Petroleum Jelly
- Seal Driver
- Arbor Press
- Loctite (#222, #242, and #277 or equivalent)

Parts Drawing - Figure 1-1

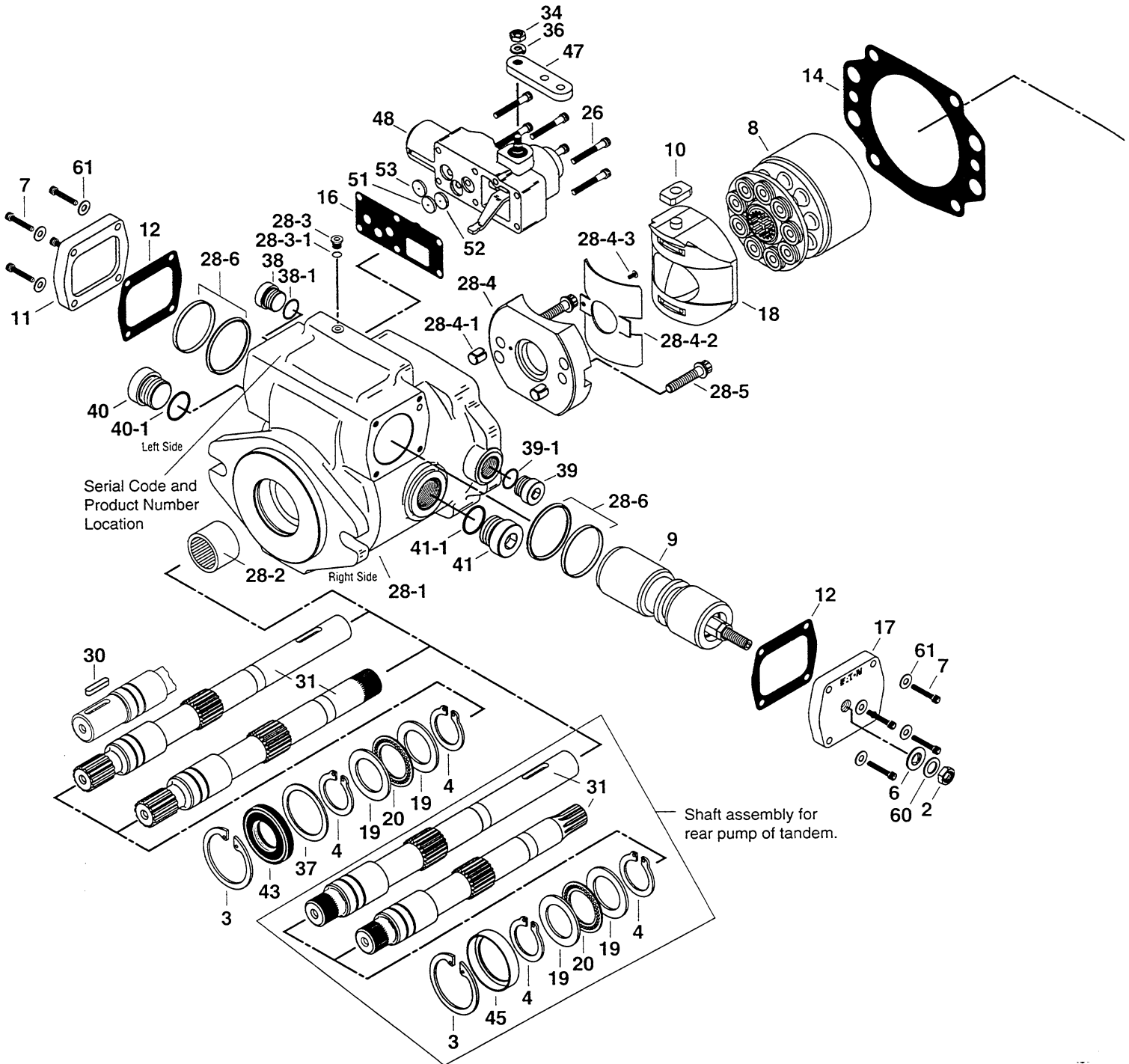

Parts Drawing - Figure 1-1

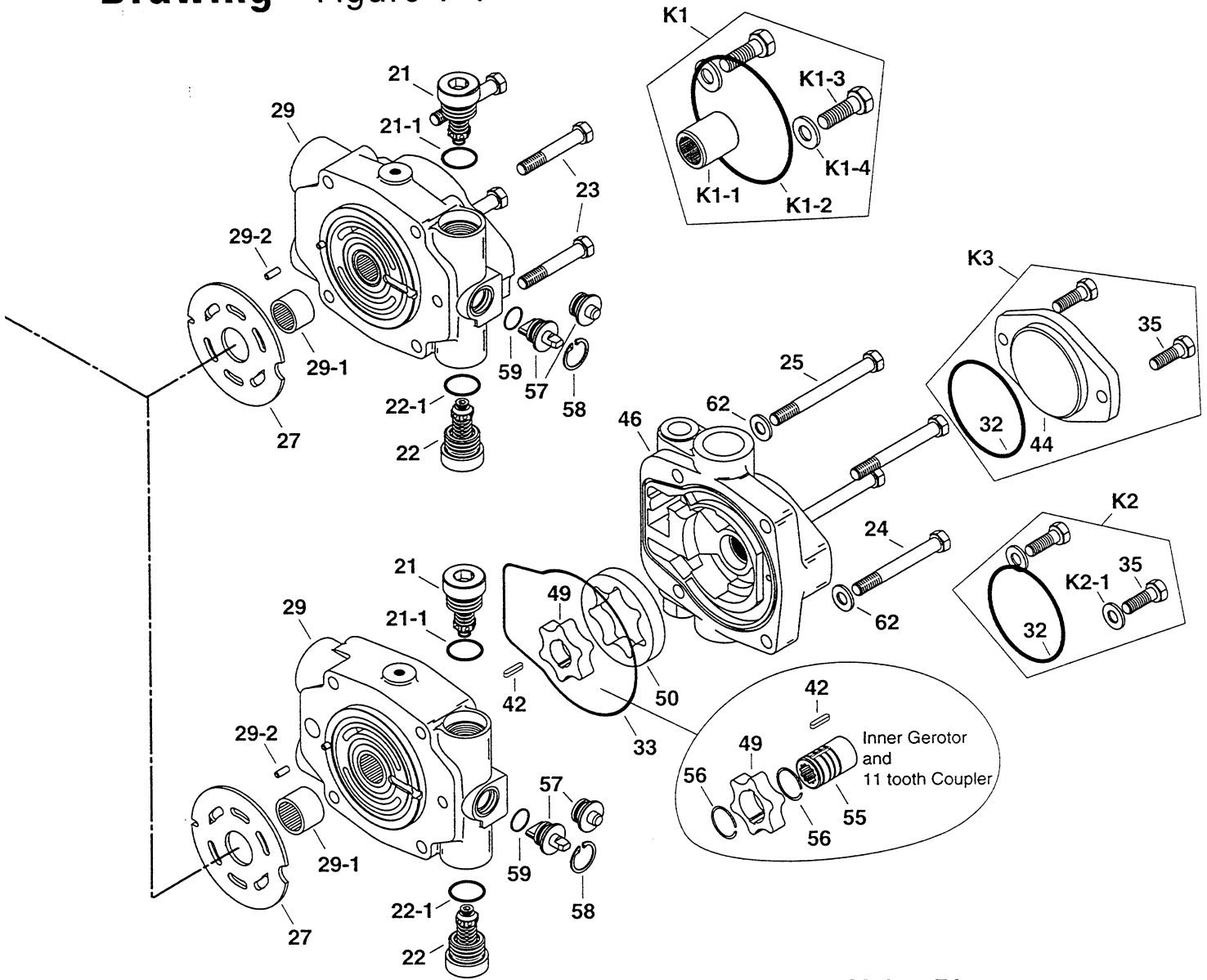

Valve Plate Identification

Note "V" notch locations

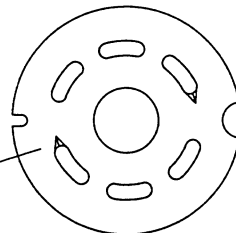

Lefthand
Rotation

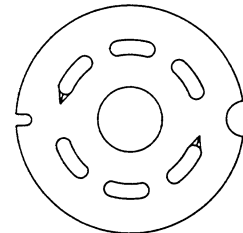

Righthand
Rotation

Parts List

Item	Qty.	Description
2	1	Jam Nut
+ 3	1	Retaining Ring
+ 4	2	Retaining Ring
+ 6	1	Seal Washer
7	8	Cap Screw, #10-24, 25.4mm [1.0 in.] Long
8	1	Rotating Kit Assenbly
9	1	Servo Piston Assembly
10	1	Servo Piston Follower
11	1	Cover Plate
+ 12	2	Cover Plate Gasket
+ 14	1	Housing Gasket
+ 16	1	Control Housing Gasket
17	1	Cover Plate
18	1	Camplate
19	2	Thrust Race
20	1	Thrust Bearing
21	1	Relief Valve for Port "C"
+ 21-1	1	O-ring, 2.46 mm Dia. x 19.18 mm I.D. [.097 in. Dia. x .755 in. I.D.]
22	1	Relief Valve for Port "D"
+ 22-1	1	O-ring, 2.46 mm Dia. x 19.18 mm I.D. [.097 in. Dia. x .755 in. I.D.]
23	4	Cap Screw, 3/8-16, 57.2 mm [2.25 in.] Long
24	2	Cap Screw, 3/8-16, 88.9 mm [3.5 in.] Long
25	2	Cap Screw, 3/8-16, 101.6 mm [4.0 in.] Long
26	6	Cap Screw
27	1	Valve Plate
28	1	Housing Assembly
28-1	1	Housing
28-2		Bearing (press fit)
28-3	1	Plug Sub-Assembly
+ 28-3-1	1	O-ring, 1.63 mm Dia. x 6.1 mm I.D. [.064 in. Dia. x .239 in. I.D.]
28-4	1	Cradle Sub-Assembly
28-4-1	2	Dowel Bushing
28-4-2	1	Bushing
28-4-3	1	Cap Screw, Button Head
28-5	2	Cap Screw
28-6	2	Seal Sub-Assembly
29	1	Backplate Assembly
29-1	1	Bearing (press fit)
29-2	1	Roll Pin
31	1	Drive Shaft
+ 32	1	O-ring, 1.59 mm Dia. x 82.55 mm I.D. [.0625 in. Dia. x 3.25 in. I.D.]
+ 33	1	Molded O-ring
34	1	Nut
35	2	Cap Screw, 3/8-16, 25.4 mm [1.0 in.] Long
36	1	Lockwasher
37	1	Washer
38	1	Plug
+ 38-1	1	O-ring, 2.21 mm Dia. x 16.36 mm I.D. [.087 in. Dia. x .644 in. I.D.]

Parts List

Item	Qty.	Description
39	1	Plug
+ 39-1	1	O-ring, 2.21 mm Dia. x 16.36 mm I.D. [.087 in. Dia. x .644 in. I.D.]
40	1	Plug
+ 40-1	1	O-ring, 2.95 mm Dia. x 23.47 mm I.D. [.116 in. Dia. x .924 in. I.D.]
41	1	Plug
+ 41-1	1	O-ring, 2.95 mm Dia. x 23.47 mm I.D. [.116 in. Dia. x .924 in. I.D.]
42	1	Key
+ 43	1	Shaft Seal
44	1	Cover Plate
45	1	Spacer
46	1	Charge Pump Adapter Assembly
47	1	Control Arm
48	1	Manual Servo Control Assembly
49	1	Inner Ring Gerotor
50	1	Outer Ring Gerotor
51	1	Supply Orifice
52	1	Control Valve Orifice
53	1	Control Valve Orifice
57	1	Dump Valve Actuator or Plug
+ 58	1	Retaining Ring
+ 59	1	Quad-ring, 1.59 mm Dia. x 15.9 mm I.D. [.0625 in. Dia. x .625 in. I.D.]
60	1	Washer
61	8	Washer
62	3	Washer

Kits

K1	1	Tandem Servo Piston Pump Mounting Kit
K1-1	1	Coupler
+ K1-2	1	O-ring, 1.59 mm Dia. x 101.6 mm I.D. [.0625 in. Dia. x 4 in. I.D.]
K1-3	2	Cap Screw, 1/2-13, 25.4 mm [1.0 in.] Long
K1-4	2	Washer
K2	1	Gear Pump Mounting Kit Includes Items 32 and 35
K2-1	2	Washer
K3	1	Cover Plate Kit for "A" SAE Flange Series 82-2 Mount Includes Items 32, 35, and 44
	1	72400-908, Seal Repair Kit for single pumps (Two Required for Tandem Units)
	1	72400-900, Dump Valve Kit, includes items 57 (Actuator), 58, & 59
	1	72400-901, Dump Valve Plug Kit, includes items 57 (plug), 58, & 59

+ Parts included in 72400-908 Seal Repair Kit

Disassembly

Disassembly - Servo Controlled Piston Pump

The following instructions apply to a single servo controlled piston pump with or without a gerotor charge pump. A tandem pump assembly should be separated into individual pumps before disassembly.

1 Position the pump into a protected jaw vise, clamping onto the outer portion of the flange, with the cap screws up. Mark the relationship of the working ports (for reassembly identification) to the servo control assembly with a scribe. Remove the four cap screws retaining backplate.

No gerotor charge pump skip to step 6.

2 Lift the charge pump adapter assembly straight up off backplate, shaft, and gerotor. Gerotor may stay in adapter or on backplate.

3 Remove o-ring from charge pump adapter.

4 Remove outer gerotor ring from either the charge pump adapter or the inner gerotor ring.

Refer to Appendix A for disassembly and inspection of charge pump adapter assembly.

5 Remove the inner gerotor ring and key from drive shaft or inner gerotor ring and coupler assembly from shaft.

6 Lift backplate straight up off shaft and housing. Remove valve plate from backplate or from rotating kit assembly, still in housing.

7 From backplate, remove dump valve retaining ring, dump valve or plug, and relief valve assemblies. Note: Mark the relief valve in relationship to the cavity it was removed, for reassembly purposes.

Backplate Inspection:

- Check the bearing (press fit) in backplate. If needles remain in cage, move freely, and setting is at the dimension shown in figure 1-3, removal not required.
- Check roll pin in backplate. If tight and set to the dimension shown in figure 1-3, removal not required.

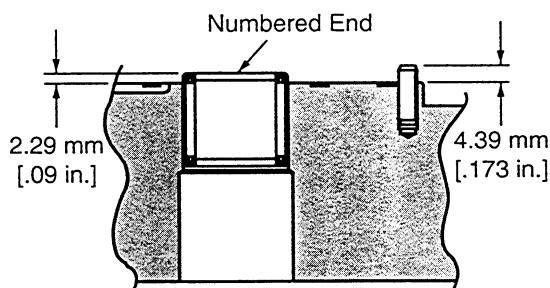

Figure 1-3

8 Remove housing gasket from housing or backplate.

9 With pump still in vise, remove the six cap screws retaining the manual servo control assembly. Remove the control assembly and control housing gasket from the housing. Remove orifice plates, noting location for reassembly. Remove nut and lock washer from control arm, remove arm. Note position of control arm for reassembly.

Refer to Appendix B for disassembly and Inspection of control assembly.

10 To remove rotating kit assembly from housing, first remove pump from vise holding the rotating kit assembly in position. Lower pump so that the shaft end (flange end) is up. Set the rear of housing onto table with housing flat and rotating kit assembly at rest on table. (Hole in table, for protruding shaft, is required.) Lift and remove the housing and shaft from rotating kit assembly, and camplate.

11 Remove camplate from rotating kit assembly and servo piston follower from camplate.

Refer to Appendix C for disassembly and Inspection of rotating kit.

Camplate Inspection:

- The finish on the piston shoe surfaces of the camplate should show no signs of scoring.
- Inspect camplate bushing surface for wear and surface for coating transfer from bushing.

12 To remove servo piston assembly from housing, start with the four each cap screws and washers retaining each cover plate.

13 In removing the cover plate from the servo piston bolt, remove jam nut, washer, and seal washer. Hold the servo piston bolt with hex key and unscrew cover plate off of bolt.

14 Remove servo piston assembly and seal sub-assemblies (two sets) from housing. Note: Disassembly of servo piston assembly is not required.

15 Remove retaining ring from the front of housing. Press the shaft, shaft seal or spacer, and washer from housing. Remove retaining ring, thrust washer, thrust bearing, second thrust washer, and second retaining ring from shaft.

Disassembly and Reassembly

Housing Inspection:

- Check the bearing (press fit) in housing. If needles remain in cage, move freely, and setting at the dimension shown in figure 1-4, removal not required.

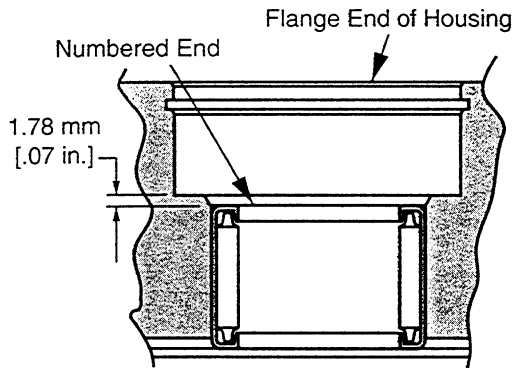

Figure 1-4

16 To remove cradle sub-assembly, remove the two cap screws retaining cradle inside housing. Move the cradle sub-assembly back-an-forth to release dowel bushings and removing cradle sub-assembly from housing.

17 Remove button head cap screw to remove bushing from cradle.

Bushing Inspection:

- Inspect bushing for contamination embedment within coating of bushing surface coming in contact with camplate.

18 Remove all plugs from housing.

19 Discard the shaft seal, gaskets, and o-rings from all assemblies. Replace with new seals upon reassembly.

Reassembly - Servo Controlled Piston Pump

- 1** All parts should be cleaned and critical moving parts lubricated before reassembly.
- 2** If necessary, Press new bearing in housing to dimension shown in figure 1-4 with the numbered end of bearing outward.
- 3** Install the two new seal sub-assemblies into the servo piston cavity of housing.
- 4** Screw the cover plate onto the servo piston assembly. Install new cover plate gasket in place on housing. Install servo piston assembly and cover plate into servo piston bore in right side of housing (as shown in figure 1-1 and figure 1-5). Retain cover plate with four each washers and cap screws. Torque cap

screws 4.5 to 5.4 N•m [40 to 48 lbf•in.]. To obtain neutral, centering the servo piston assembly is required. Measure in from the left side and set servo piston 12.7 mm [.5 in.] from surface of housing servo bore as shown in figure 1-5.

Note: Re-adjustment may be required for neutral at unit start-up.

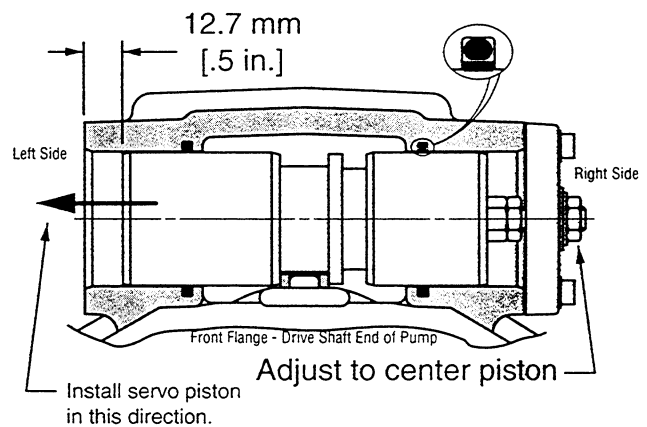

Figure 1-5

5 Install new seal washer, washer, and jam nut to servo piston bolt. Holding servo piston bolt with hex key wrench Torque jam nut 17 to 18 N•m [150 to 160 lbf•in.]. Check the centering of servo piston assembly. Install new cover plate gasket and cover plate to left side of servo piston and retain with four each washers and #10-24 cap screws. Torque cap screws 4.5 to 5.4 N•m [40 to 48 lbf•in.].

6 To assemble cradle sub-assembly, press dowel bushings into cradle and install bushing onto cradle retaining with button head cap screw. Torque button head cap screw 1.6 to 1.8 N•m [14 to 16 lbf•in.]

7 Place cradle sub-assembly into housing making sure dowel bushings and cradle are completely seated into housing. Retain cradle sub-assembly with two cap screws after applying loctite #277 (or equivalent) to the end of threads. Torque cap screws 34 to 38 N•m [25 to 28 lbf•in.].

8 To install shaft, place exterior retaining ring, thrust race, thrust bearing, second thrust race, and second retaining ring onto shaft. Position washer and shaft seal or spacer onto shaft.

9 Install shaft assembly into front of housing: For units with spacer, retain with interior retaining ring and go on to step 10. For units with shaft seal, seat seal into position with seal driver and retain with interior retaining ring.

Reassembly

10 Install servo piston follower onto camplate dowel pin. Install camplate carefully onto bushing (coat bushing surface with hydraulic oil), aligning servo piston follower with slot in servo piston assembly.

Refer to Appendix C for reassembly of rotating kit assembly.

11 To install rotating kit assembly, leave housing and shaft in the horizontal position. Holding camplate into position with screw driver thru controller linkage passageway at the top of housing, place rotating kit assembly over shaft and into housing until pistons are in against camplate. Make sure all parts are in housing completely and properly positioned. Return the pump to the vise with open end of housing up, clamping housing on the outer portion of the flange.

12 Install gasket on to housing.

13 If necessary, press new bearing and roll pin in backplate to dimension shown in figure 1-3. Bearing installed with the numbered end outward. Roll pin installed with split oriented away from bearing.

14 Install new o-ring on relief valves. Install relief valve in its original cavity in backplate that it was removed. Torque 136 to 149 N•m [100 to 110 lbf•ft.]

15 Install new Quad-ring on dump valve or plug. Install dump valve or plug and retain with retaining ring into backplate. Note: Make sure paddle of dump valve is perpendicular to relief valve axis prior to installing or damage could result.

16 Apply a small amount of petroleum jelly to the steel side of valve plate to hold in place for installation. Aligning the index pin, place the valve plate in position onto the backplate, with steel side against backplate.

17 Install backplate assembly onto housing assembly. Make sure ports are positioned correctly, valve plate and gasket stay in place.

No gerotor charge pump, skip to step 20.

18 Install key and inner ring gerotor onto shaft or coupler assembly. Lubricate inner ring gerotor.

Refer to Appendix A for reassembly of Charge relief valve in adapter plate.

19 Install o-ring and outer ring gerotor onto adapter plate.

Lubricate both o-ring and outer ring to hold in position during assembly of adapter plate. Install adapter plate onto backplate. Make sure o-ring and gerotor ring stay in place.

20 Retain backplate and adapter plate (when used) with four cap screws, Torque 37 to 42 N•m [27 to 31 lbf•ft].

Refer to Appendix B for reassembly of manual servo control assembly.

21 Install control housing gasket onto housing. Install orifices into control assembly and retain in position with petroleum jelly. Position the feedback link at 90 degrees from control housing. Install Manual servo control assembly onto housing making sure feedback link entered small groove in servo piston assembly.

22 Retain control assembly with six cap screws, torque 4.5 to 5.4 N•m [40 to 48 lbf•in].

23 Install control arm onto control assembly input arm. Retain with lock washer and nut, torque 5 to 8 N•m [4 to 6 lbf•ft]

24 Install new o-rings on all plugs. Install plugs into housing. Torque 3/4 in. plug 28 to 32 N•m [21 to 24 lbf•ft]. Torque 1-1/4 in. plug 54 to 61 N•m [40 to 45 lbf•ft].

25 Refer to start-up procedures on page 23.

Appendix A - Charge Pump Adapter Assembly

Disassembly - Charge Pump Adapter Assembly

1 Remove plug, shims, spring, and poppet from adapter assembly.

Inspection:

- Inspect the charge pump relief valve seat inside the charge pump adapter. Check to insure that seat is smooth and free of burrs or other defects.
- Inspect the charge pump relief valve spring.
- Inspect the bearing or bushing inside the charge pump adapter. The bearing needles must remain in the bearing cage and bearing at dimension shown in figure 1-2. The bushing must have no excessive scoring.
- Inspect the gerotor pocket inside the charge pump adapter assembly. It should not be scored excessively.

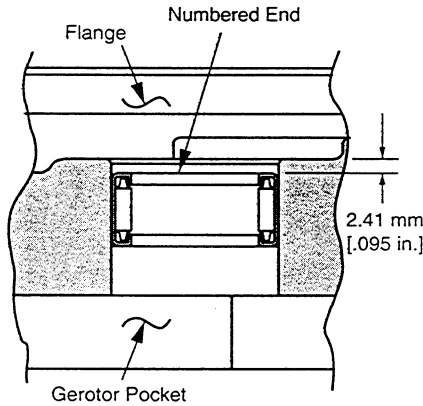
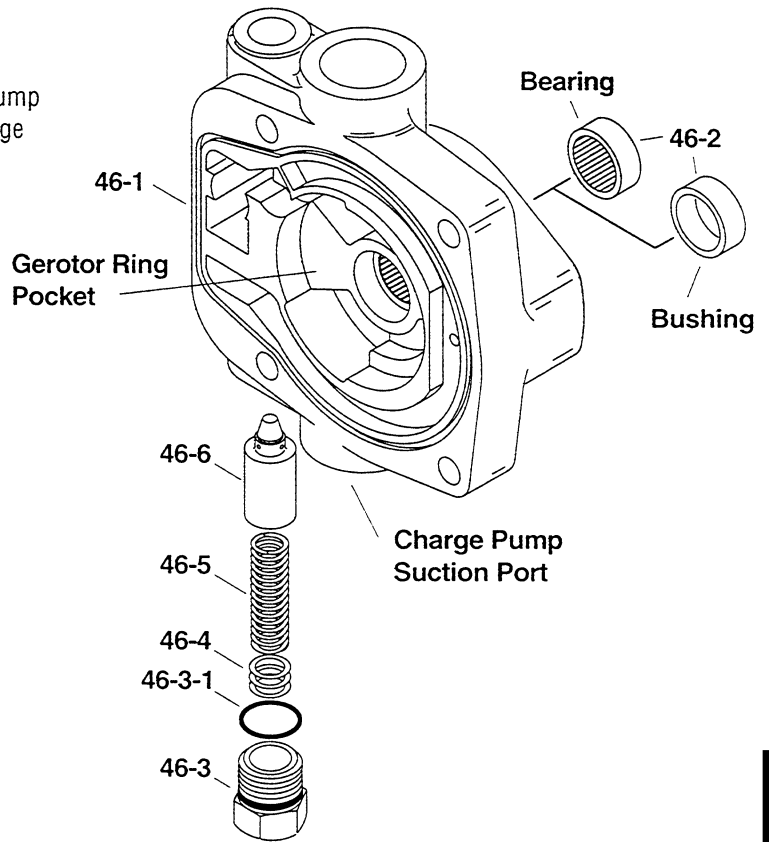

Figure 1-2



Reassembly - Charge Pump Adapter Assembly

1 If necessary, press new bearing or bushing in adapter assembly. The bearing to dimension shown in figure 1-2 with the numbered end of bearing outward and closest to mounting flange. The bushing is to be pressed flush to .254 mm [.010 in.] recessed.

2 Install poppet, spring, shims, new o-ring on plug, and plug into adapter assembly. Torque plug 40.7 to 36.6 N•m [30 to 27 lbf•ft.]

Item	Qty.	Description
46-1	1	Charge Pump Adapter
46-2	1	Bearing (press fit)
46-2	1	Bushing (press fit)
46-3	1	Plug
+ 46-3-1	1	O-ring
46-4	<i>f</i>	Shims
46-5	1	Spring
46-6	1	Poppet

f Shim as required

Appendix B - Manual Servo Control Basic Assembly

Disassembly - Manual Servo Control Assembly

- 1 Remove wiper seal with screw driver. Remove set screw retaining input shaft and remove input shaft from control housing.
- 2 Remove set screw from plug retaining valve spool and remove plug.
- 3 Remove E-ring from pin retaining feedback link and valve spool. Remove pin, feedback link, valve spool, and bell crank from control housing.
- 4 Compress spring and remove E-ring, spring retainer, spring, and second spring retainer from valve spool.
- 5 Remove o-rings from plug and input shaft. Clean all parts and lubricate in prep for reassembly.

Reassembly - Manual Servo Control Assembly

- 1 Install spring retainer, spring, and second spring retainer onto spool. Compress spring with retainer and retain with E-ring onto valve spool.
- 2 Install valve spool into control housing making sure that metering notches on valve spool can be seen in the metering ports. Notches shown in figure 2-1.
- 3 Position bell crank in housing. Slide feedback link into position between clevis on valve spool, aligning holes, and install dowel pin retaining with E-ring.
- 4 Install new o-ring onto input shaft. Hold bell crank in position with feedback link slot and align splined hole of bell crank with input shaft cavity. Install input shaft into control housing and bell crank.
- 5 Apply Loctite #242 or equivalent to set screw and install, retaining input shaft. Adjust set screw until it bottoms out on input shaft and back out one-quarter turn.
- 6 Install wiper seal on input shaft as shown in figure 2-2.
- 7 Install new o-ring onto plug, retaining valve spool, and install plug. Adjust plug until there is no play in the valve spool with input shaft held stationary. Lock in place with set screw. Torque set screw 2 to 3 N•m [17 to 25 lbf•in].

Appendix B - Manual Servo Control Basic Assembly

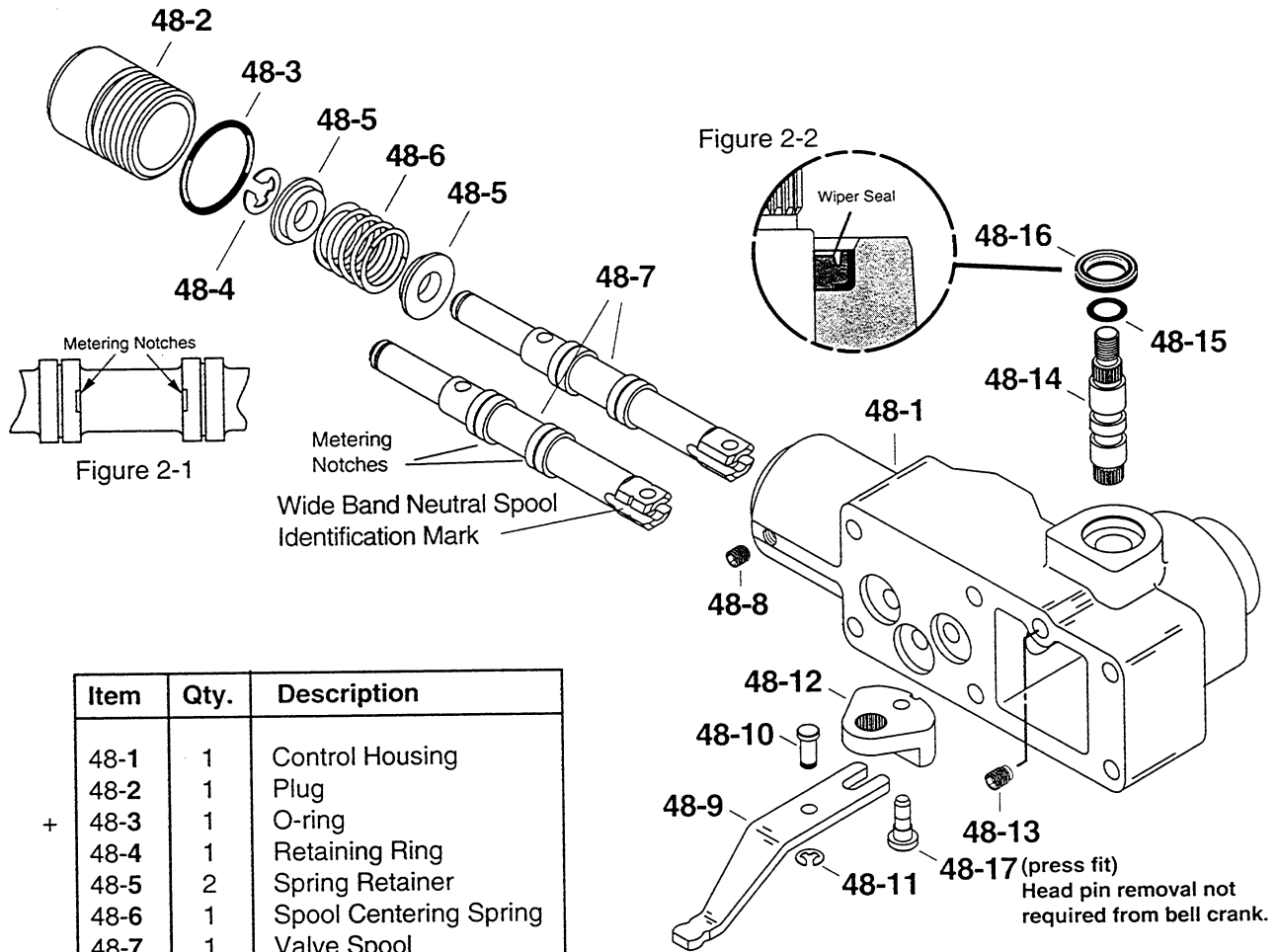

Item	Qty.	Description
48-1	1	Control Housing
48-2	1	Plug
+ 48-3	1	O-ring
48-4	1	Retaining Ring
48-5	2	Spring Retainer
48-6	1	Spool Centering Spring
48-7	1	Valve Spool
48-8	1	Set Screw
48-9	1	Feedback Link
48-10	1	Dowel Pin
48-11	1	Retaining Ring
48-12	1	Bell Crank
48-13	1	Set Screw
48-14	1	Input Shaft
+ 48-15	1	O-ring
+ 48-16	1	Wiper Seal
48-17	1	Head Pin (press fit)

48-17 (press fit)
Head pin removal not required from bell crank.

Appendix B - Manual Servo Control Assembly Options

Disassembly - Destroke Valve Assembly Option

- 1 Remove the two cap screws and lock washers from manifold. Removing destroke valve assembly and two o-rings.
- 2 Remove destroke valve from manifold in order to remove o-rings and back-up washers. Note in order to remove destroke valve the solenoid may need to be removed from core first (not shown).

Reassembly - Destroke Valve Assembly Option

- 1 Install new o-rings and back-up washers onto destroke valve.
- 2 Install destroke valve into manifold by hand until top o-ring is met by manifold. Then wrench tighten to 34 N•m [25 lbf•ft.] max. Loosen Nut retaining coil to reposition if necessary and re-torque 5.4 to 7 N•m [4 to 5 lbf•ft.].
- 3 Lubricate the two o-rings and install onto manifold. Install destroke valve assembly onto control assembly. Retain with lock washers and cap screws. Torque 3 to 3.5 N•m [27 to 31 lbf•in.].

Item	Qty.	Description
48-18	2	O-ring
48-19	1	Destroke Valve Assy.
48-19-1	1	Manifold
48-19-2	1	Destroke Valve
48-19-2A	1	O-ring
48-19-2B	2	Back-up Washer
48-19-2C	1	O-ring
48-20	2	Lock Washer
48-21	2	Cap Screw
48-22	1	O-ring
48-23	1	Adapter, Neutral Lockout
48-24	1	Ball
48-25	1	O-ring
48-26	1	Pin
48-27	1	Set Screw
48-28	1	Neutral Lockout Switch
48-29	1	Ball Plunger
48-30	1	Nut, Seal

Destroke Valve
Assembly
Option

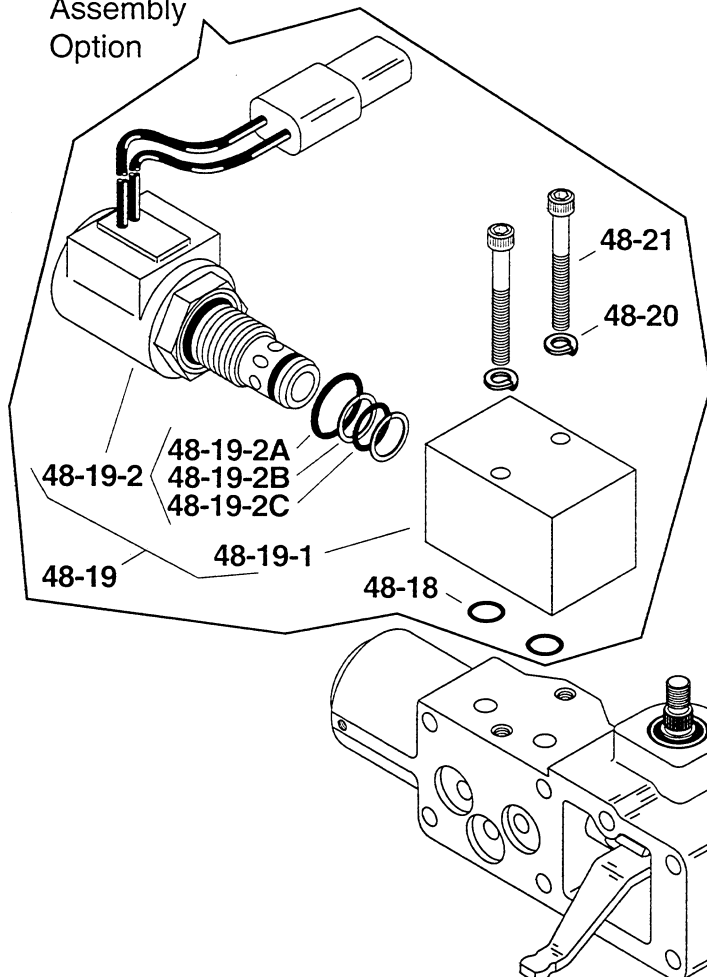

Neutral Lockout
Switch Option

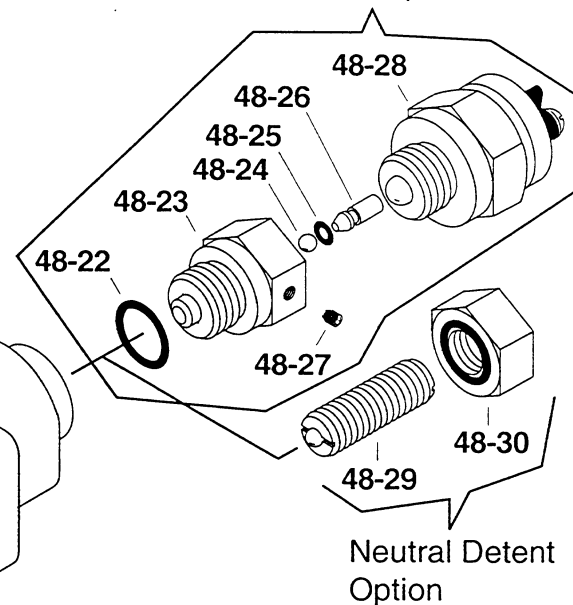

Neutral Detent
Option

Appendix B - Manual Servo Control Assembly Options

Disassembly - Neutral Lockout Switch Assembly Option

- 1 Loosen set screw in adapter and remove neutral lockout switch from adapter.
- 2 Remove Neutral lockout adapter from control assembly.
- 3 Remove pin, ball, and o-rings from adapter.

Reassembly - Neutral Lockout Switch Assembly Option

- 1 Install new o-ring onto adapter and new o-ring onto pin.
- 2 Install ball and pin into adapter. Lubricate with petroleum jelly to hold in place during installation.
- 3 Install adapter into control assembly. Torque 60 to 70 N•m [44 to 53 lbf•ft].
- 4 Apply Loctite #222 or equivalent to threads of switch and install neutral lockout switch into adapter. The adjustment procedures for the switch are as follows.

a) Install switch, while moving control arm back and forth, until "detent" action is detected. Back out the switch until the "detent" action is very slight.

b) Obtain a test light or use a multimeter. Attach the leads from the test light to the switch or the wiring connector.

c) Move the control arm out of the detent position. The test light will go on. Screw in the switch until the light goes off. Mark this as position "A". See figure 2-3. Move the control arm to the detent position and the test light should come back on.

d) Leaving the control arm in the detent position, the light will remain on. Screw in the switch until the light goes off. Mark this position "B".

e) Unscrew the switch one third of the distance between "B" and "A". Install and tighten the hex socket head set screw in one of the upper quadrants of the hex of the switch adapter. See figure 2-3. Torque set screw 3.2 to 3.8 N•m [28 to 34 lbf•in.]

5 Test the switch by moving the control arm to the detent position, the light should be on. Move the control arm out of detent, the light should go off.

6 Remove test light and put servo control Assembly into operation.

Disassembly - Neutral Detent Option

- 1 Loosen seal nut and remove ball plunger from control housing.

Reassembly - Neutral Detent Option

- 1 Install ball plunger into control housing until contact with bell crank detent is detected. After contact, screw in 1/2 turn and retain with seal nut. Torque nut 14 to 30 N•m [10 to 22 lbf•ft].

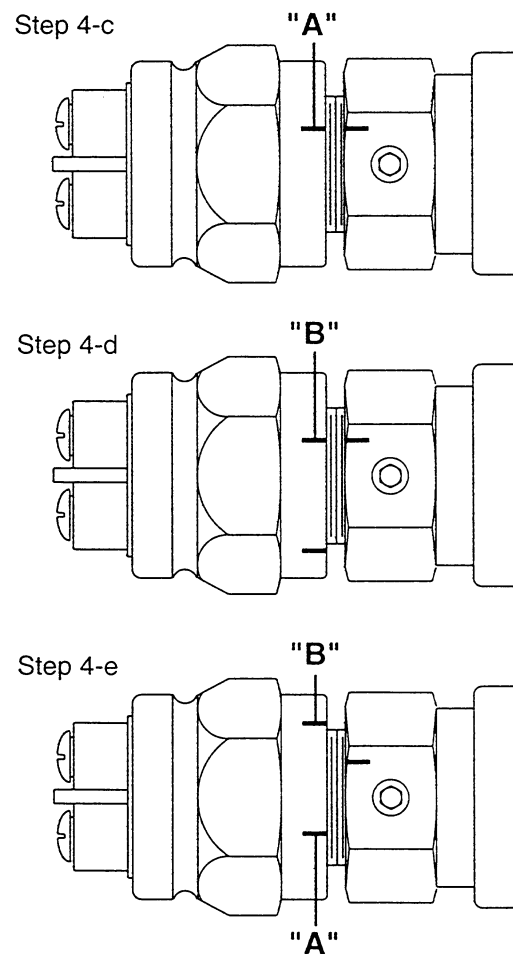

Figure 2-3

Appendix C - Rotating Kit Assembly

Disassembly - Rotating Kit Assembly

Disassembly of rotating assembly is required for inspection only.

1 Remove the nine piston assemblies, spider, and spider pivot from piston block.

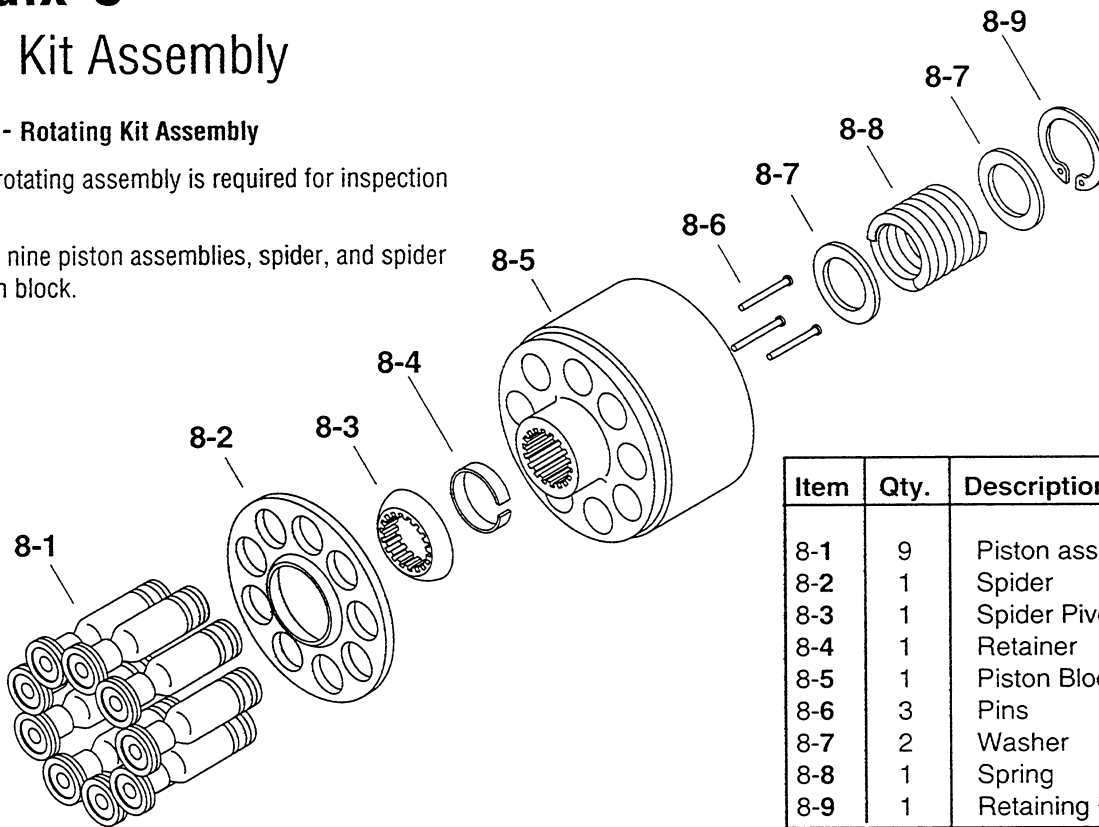

Item	Qty.	Description
8-1	9	Piston assemblies
8-2	1	Spider
8-3	1	Spider Pivot
8-4	1	Retainer
8-5	1	Piston Block
8-6	3	Pins
8-7	2	Washer
8-8	1	Spring
8-9	1	Retaining Ring

Inspection:

- Examine the O.D. of the pistons for finish condition. They should not show wear or deep scratches. Inspect the shoes for a snug fit on the ball end of the pistons and a flat smooth surface that comes in contact with the camplate. **Do not lap piston shoes.**

- Examine the spider for wear in the pivot area.
- Examine the pivot to insure smoothness and no signs of wear.

- Inspect the piston block surface that makes contact with valve plate. This surface should be smooth and free of deep scratches. **Do not lap piston block.**

- The pistons should move freely in the piston block bore. If they are sticky in the bore, examine the bore for scoring or contamination.

2 To inspect pins and spring **Caution** should be taken in removing spring. The **spring is highly compressed** and the retaining ring should not be removed without compressing the spring safely.

The following parts are required to disassemble the piston block:

- 2 ea. 3/8 in. I.D. x 1-1/8 in. O.D. flat washers
- 1 ea. 3/8 in. x 3-1/4 in. N.C. cap screw, and
- 1 ea. 3/8 in. N.C. nut

To remove spring, place one of the flat washers over the 3/8 in. x 3-1/4 in. cap screw. Put cap screw through the center of the piston block and apply the second washer. Let washer rest on the three pins and retain with nut. Turning nut and compressing spring inside the block. Use a pair of retaining ring pliers and remove the internal retaining ring. Remove nut, bolt, and the two washers from block. Removing the washer, spring, second washer, three pins, and pin keeper at the same time.

Reassembly - Rotating Kit Assembly

1 To reassemble the rotating kit assembly complete the following: Compress the pin keeper and install in the spline of the piston block. Install the three pins with head end to the inside of the block and position in the special grooves of the piston block spline.

2 Install the washer, spring, and second washer into the piston block. Use the two 3/8 in. I.D. washers, nut, and 3/8 in. x 3-1/4 in. cap screw to compress the spring and retain with retaining ring. Remove the nut, cap screw, and the two washers.

3 Install the pivot onto the three pins, spider on the pivot, and piston assemblies thru the spider and into piston block, resting on spider.

Fault - Logic Troubleshooting

This fault - logic troubleshooting guide is a diagnostic aid in locating transmission problems.

Match the transmission symptoms with the problem statements and follow the action steps shown in the box diagrams. This will give expedient aid in correcting minor problems eliminating unnecessary machine down time.

Following the fault - logic diagrams are diagram action comments of the action steps shown in the diagrams. Where applicable, the comment number of the statement appears in the action block of the diagrams.

Explanatory Diagram

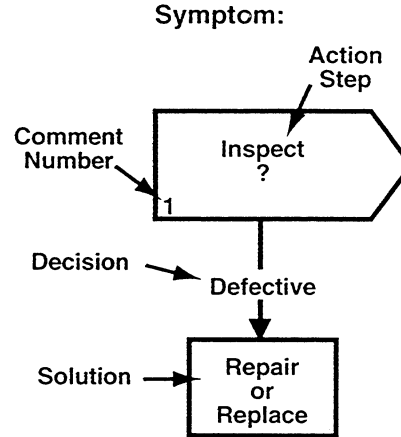

Recommended Gauge Locations

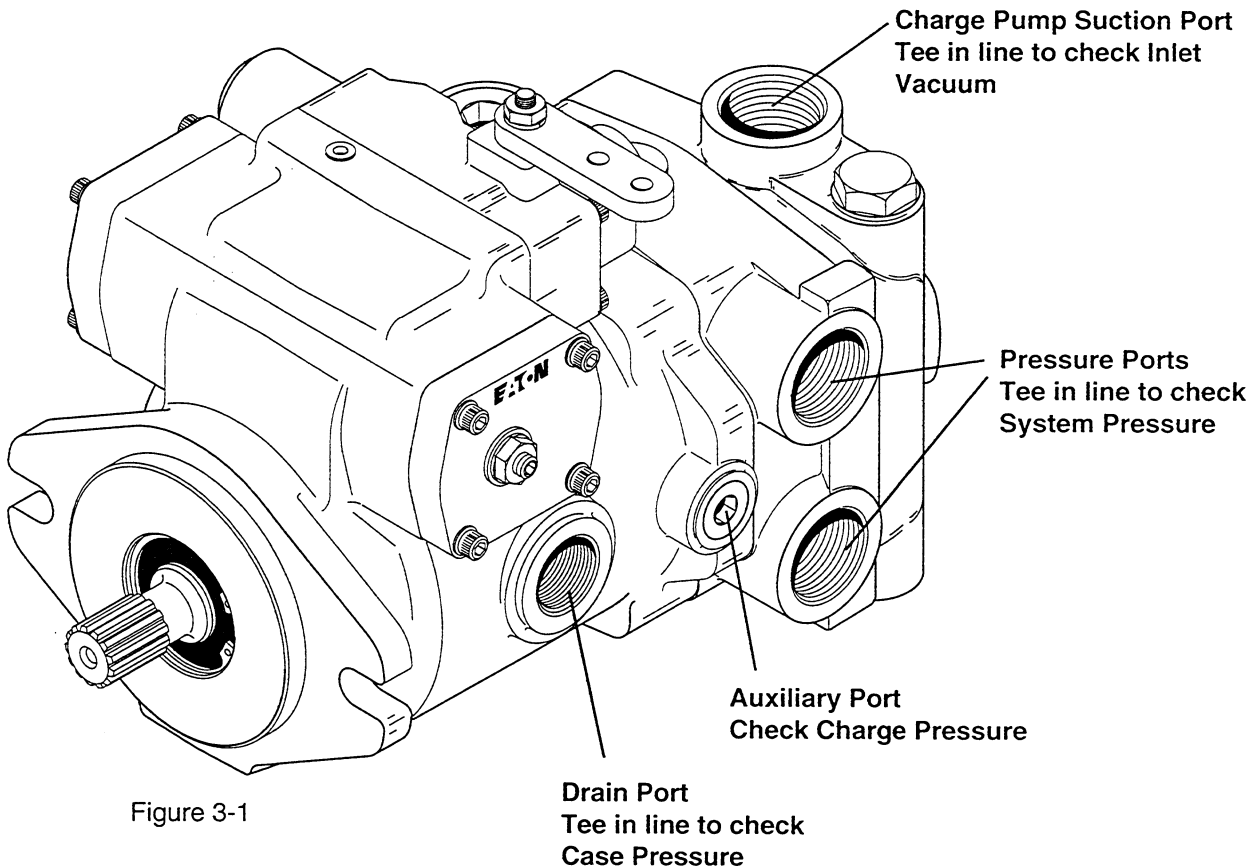

Figure 3-1

Gauges Recommended

- Inlet vacuum gauge: 207 bar to 0 bar [30 PSI to 30 inHg]
- System pressure gauge: 700 bar [10,000 PSI]
- Charge pressure gauge: 0 to 50 bar [0 to 600 PSI]
- Case pressure gauge: 0 to 25 bar [0 to 300 PSI]

Fault - Logic Trouble Shooting

Symptom: Neutral Difficult or Impossible to Find

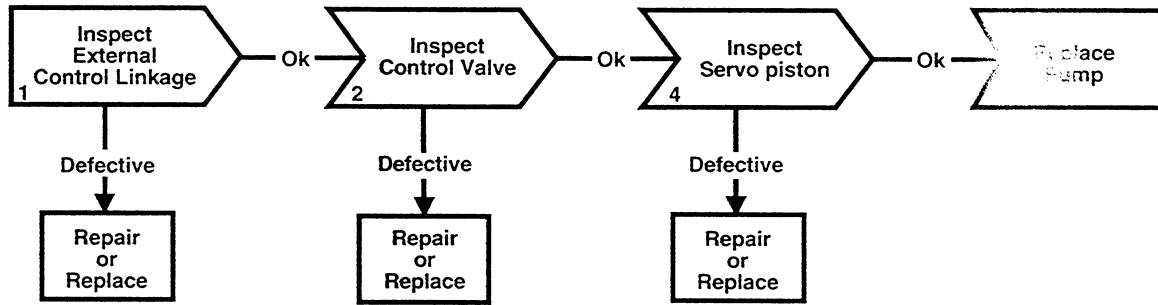

Symptom: System Operating Hot

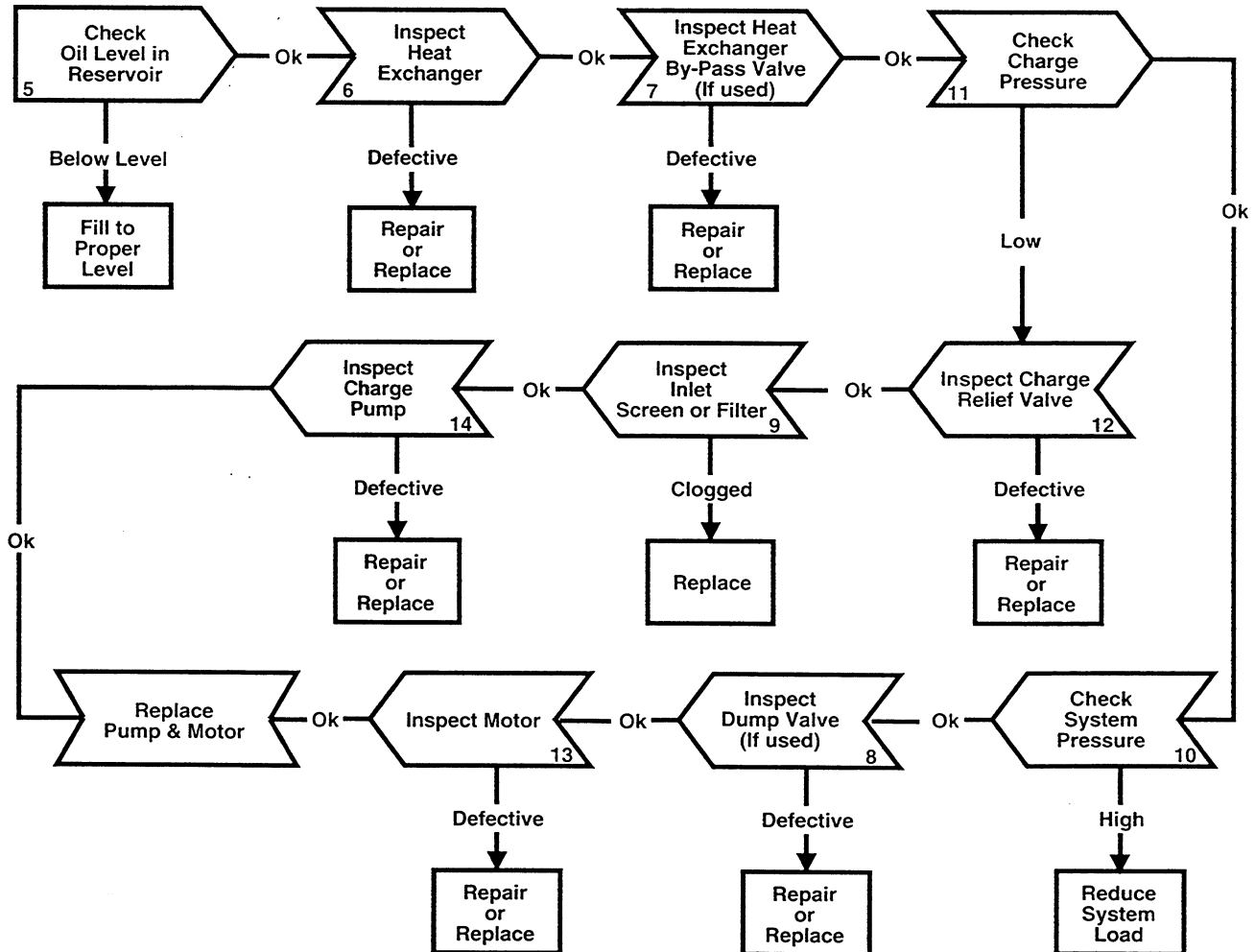

Fault - Logic Trouble Shooting

Symptom: Operates in One Direction Only

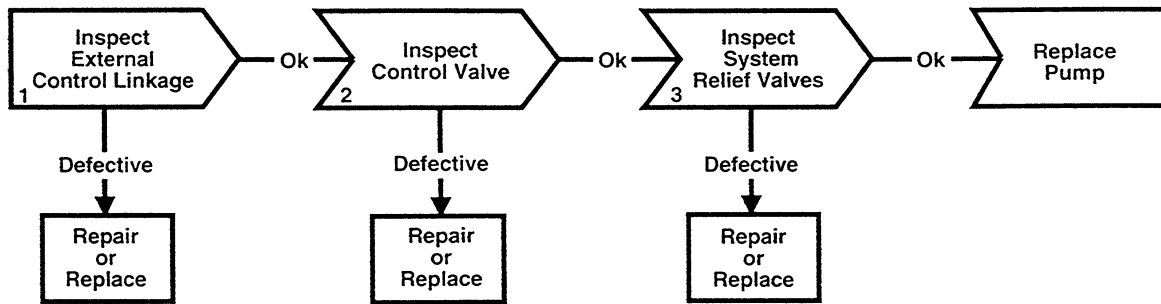

Symptom: System Response Sluggish

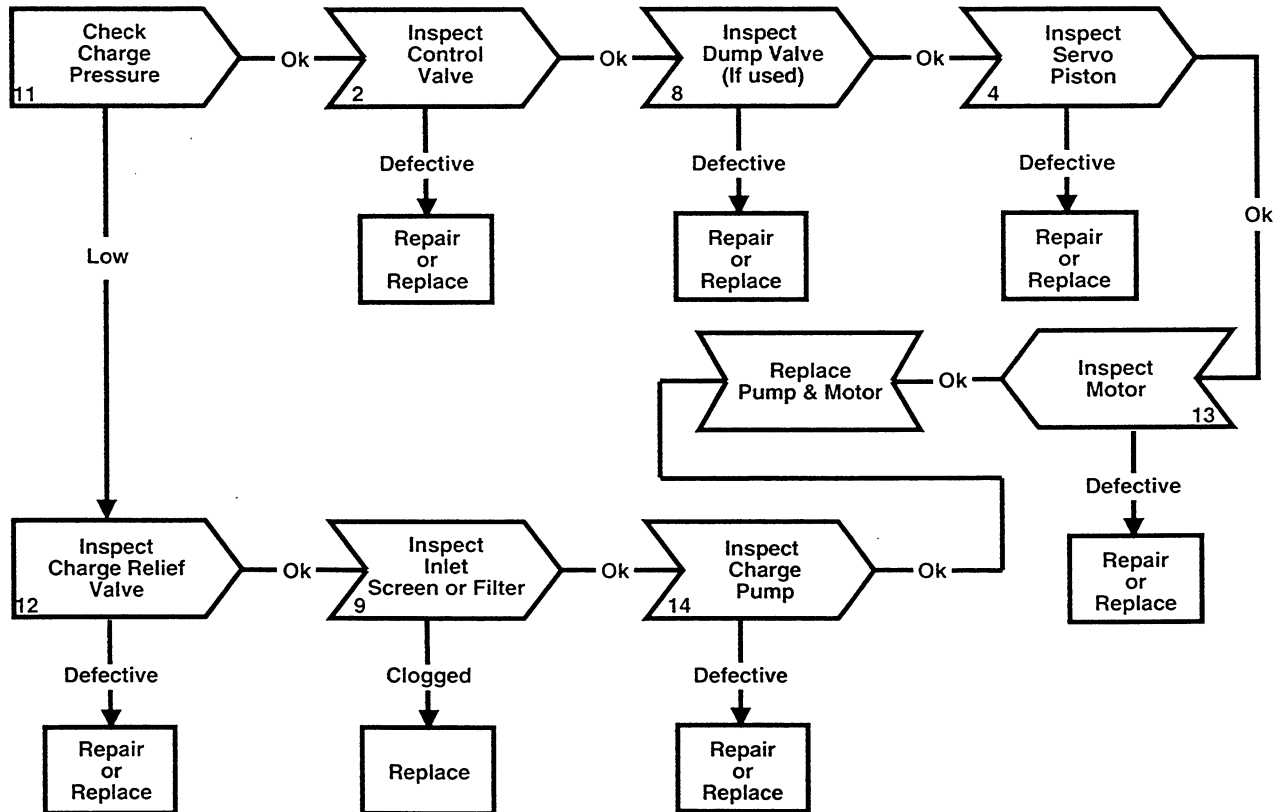

Fault - Logic Trouble Shooting

Symptom: System Will Not Operate in Either Direction

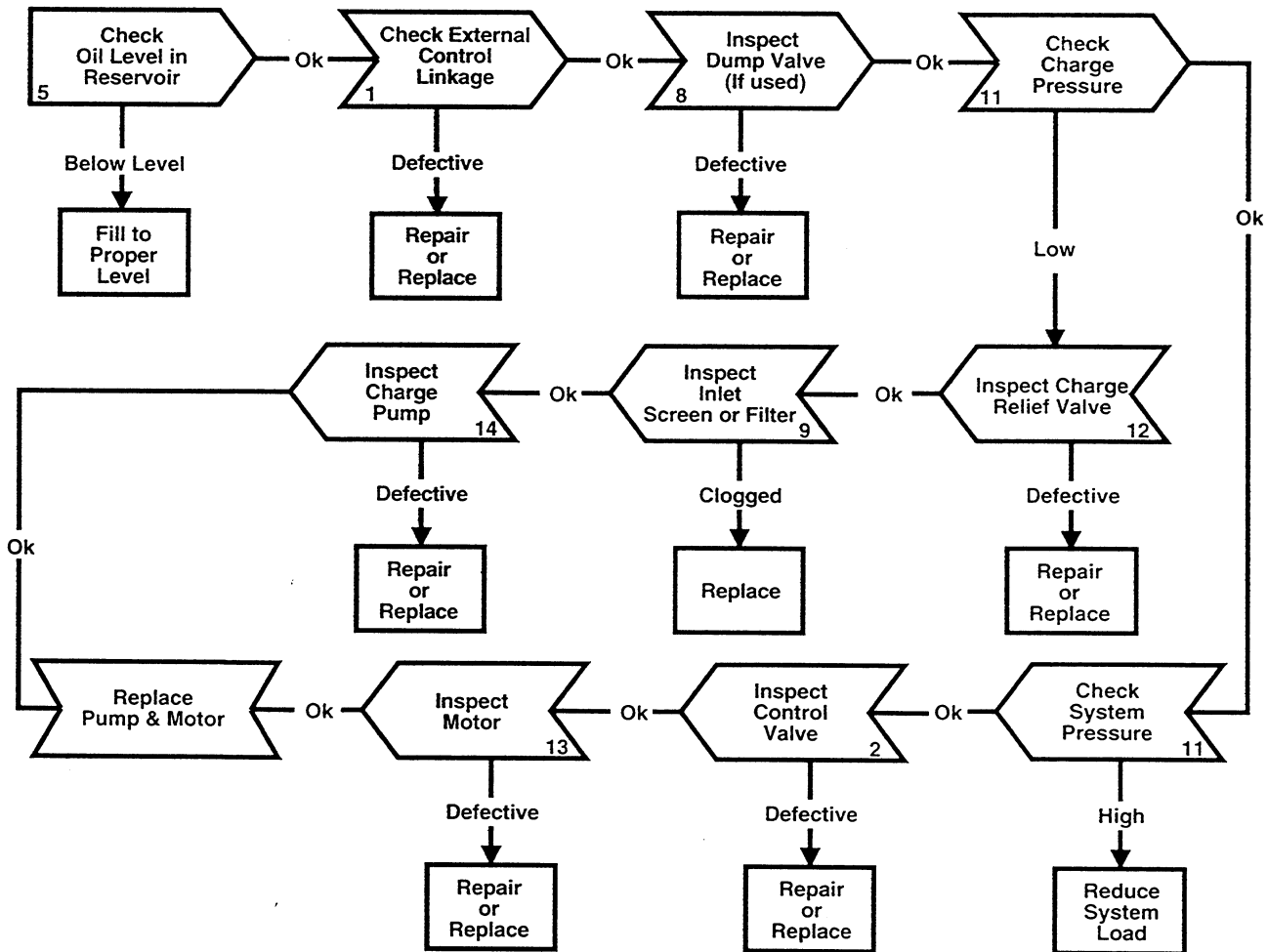

Fault - Logic Trouble Shooting

Diagram Action Step Comments

- 1 **Inspect External Control Linkage for:**
 - a. misadjusted or disconnected
 - b. binding, bent, or broken
- 2 **Inspect Control Valve for:**
 - a. plugged control orifice(s)
 - b. damaged mounting gasket
 - c. misadjusted, damaged or broken neutral return spring
 - d. broken control connector pin
 - e. faulty destroke valve (if used)
 - f. galled or stuck control spool
 - g. neutral detent or lockout switch misadjusted (if used)
- 3 **Inspect System Relief Valves * for:**
 - a. improper pressure relief setting
 - b. damaged or broken spring
 - c. valve held off seat
 - d. damaged valve seat
- 4 **Inspect Servo Piston for:**
 - a. misadjusted, damaged or broken neutral return spring assembly
 - b. galled or stuck servo piston
 - c. damaged or missing o-ring and/or back-up ring
- 5 **Check Oil Level in Reservoir:**
 - a. consult owner/operators manual for the proper type fluid and level
- 6 **Inspect Heat Exchanger for:**
 - a. obstructed air flow (air cooled)
 - b. obstructed water flow (water cooled)
 - c. improper plumbing (inlet to outlet)
 - d. obstructed fluid flow
- 7 **Inspect Heat Exchanger By-Pass Valve for:**
 - a. improper pressure adjustment
 - b. stuck or broken valve
- 8 **Inspect Dump Valve for: (if used)**
 - a. held in a partial or full open position
- 9 **Inspect Inlet Screen or Filter for:**
 - a. plugged or clogged screen or filter element
 - b. obstructed inlet or outlet
 - c. open inlet to charge pump
- 10 **Check System Pressure:**
 - a. See figure 3-1 for location of pressure gauge installation
 - b. consult owner/operators manual for maximum system relief valve settings
- 11 **Check Charge Pressure:**
 - a. See figure 3-1 for location of charge pressure gauge installation
 - b. consult owner/operators manual for maximum charge relief valve settings
- 12 **Inspect Charge Relief Valve for:**
 - a. improper charge relief pressure setting *
 - b. damaged or broken spring
 - c. poppet valve held off seat
- 13 **Inspect Motor for:**
 - a. consult owner/operator manual for motor operation and trouble shooting
- 14 **Inspect Charge Pump for:**
 - a. broken or missing drive key
 - b. damaged or missing o-ring
 - c. excessive gerotor clearance
 - d. galled or broken gerotor set

*** System/Charge Relief Valve
Pressure Settings**

Inlet Vacuum	.203 bar [6 inHg] max.
Case Pressure	1.7 bar [25 PSI] maximum
Charge Pressure	17.24 to 20.68 bar [250 to 300 PSI]
System Pressure	345 bar [5000 PSI] maximum 207 bar [3000 PSI] continuous

The high pressure relief valves are all factory preset and cannot be readjusted.

The pressure setting is stamped on each valve with a three digit number. To identify, multiply the noted number by 10 to get the valves pressure setting.

Example: 10 x 500 = [5000 PSI] 345 bar

Start-up Procedure

When initially starting a new or a rebuilt transmission system, it is extremely important that the start-up procedure be followed. It prevents the chance of damaging the unit which might occur if the system was not properly purged of air before start-up.

- 1 After the transmission components have been properly installed, fill the servo pump housing at least half full with filtered system oil. Connect all hydraulic lines and check to be sure they are tight.
- 2 Install and adjust all control linkage.
- 3 Fill the reservoir with an approved oil that has been filtered through a 10 micron filter. Refer to Eaton Hydraulics Technical Datasheet number 3-401 titled Hydraulic Fluid Recommendations.
- 4 Gasoline or L.P. engines: remove the coil wire and turn the engine over for 15 seconds. Diesel engines: shut off the fuel flow to the injectors and turn the engine over for 15 seconds.
- 5 Replace the coil wire or return the fuel flow to the injectors. Place the transmission unit in the neutral position, start the engine and run it at a low idle. The charge pump should immediately pick up oil and fill the system. If there is no indication of fill in 30 seconds, stop engine and determine the cause.
- 6 After the system starts to show signs of fill, slowly move pump camplate to a slight cam angle. Continue to operate system slowly with no load on motors until system responds fully.
- 7 Check fluid level in the reservoir and refill if necessary to the proper level with an approved filtered oil.
- 8 Check all line connections for leaks and tighten if necessary.
- 9 The machine is now ready to be put into operation.
- 10 Frequent filter changes are recommended for the first two changes after placing the machine back into operation. Change the first filter in 3-5 hours and the second at approximately 50 hours approx. hours. Routinely scheduled filter changes are recommended for maximum life of the hydraulic system.

Notes

**Order parts from number 6-633 Parts Information booklet.
Each order must include the following information.**

1. Product and/or Part Number
2. Serial Code Number
3. Part Name
4. Quantity

Eaton Corporation
Hydraulics Division
15151 Hwy. 5
Eden Prairie, MN 55344
Telephone 612/937-9800
Fax 612/937-7130

Eaton Ltd.
Hydraulics Division
Glenrothes, Fife
Scotland, KY7 4NW
Telephone 44/592-771-771
Fax 44/592-773-184

CONTENTS

	Page
FORD 2.3 LITER ENGINE	6-3
TO REMOVE ENGINE	6-4
TO INSTALL ENGINE	6-5
TO CHANGE ENGINE TIMING BELT ..	6-7
LUBRICATION	6-9
ENGINE	6-9
COOLING SYSTEM	6-9
ENGINE BELT	6-10
AIR INTAKE SYSTEM	6-11
AIR FILTER INDICATOR	6-11
AIR FILTER	6-11
TO REPLACE AIR FILTER ELEMENT	6-12
FUEL SYSTEM - GASOLINE	6-13
FUEL FILTERS	6-13
CARBURETOR	6-13
FUEL SYSTEM - LPG	6-14
LPG FUEL TANK	6-16
TO CHANGE LPG FUEL TANK	6-18
FUEL FILTER LOCK	6-19
VAPORIZER-REGULATOR	6-19
CARBURETOR	6-19
OIL PRESSURE SWITCH	6-20
LPG FUEL TROUBLESHOOTING ...	6-20
GOVERNOR ACTUATOR (LSG ENGINE)	6-21
TO REPLACE GOVERNOR ACTUATOR (LSG ENGINE)	6-21
TO ADJUST GOVERNOR (LSG ENGINE)	6-22
GOVERNOR TROUBLESHOOTING (LSG ENGINE)	6-23
GOVERNOR ACTUATOR (LRG ENGINE)	6-26
TO REPLACE GOVERNOR ACTUATOR (LRG ENGINE)	6-26
IGNITION SYSTEM	6-28
SPARK PLUGS	6-28
TO REPLACE SPARK PLUGS	6-28
ENGINE IGNITION TIMING	6-28
CYLINDER HEAD	6-28
VALVE TAPPET CLEARANCE	6-28
ENGINE ELECTRICAL SYSTEM	6-29
TO REPLACE ENGINE STARTER ...	6-29
TO REPLACE ENGINE STARTER WITH AIR CONDITIONING	6-30
TO REPLACE ENGINE ALTERNATOR	6-31
TO REPLACE ENGINE ALTERNATOR WITH AIR CONDITIONING	6-32

GAS ENGINE SERVICE MANUALS

FORD LSG-423 (2.3 Litre)
TENNANT Part Number 61875

FORD LRG-423 (2.3 Litre)
TENNANT Part Number 21791

FORD LRG-425 (2.5 Litre)
TENNANT Part Number 385439

FORD 2.3 LITER ENGINE

The Ford 2.3 liter engine in the early model 800/810 G/LP machines has a LSG-423 designation. Later model 800/810 G/LP machines use a Ford 2.3 liter engine with a LRG-423 designation.

The easiest way to distinguish which engine your machine is equipped with is the LSG-423 has a distributor and distributor cap. The LRG-423 does not have a distributor or distributor cap, instead, the spark plug wires are attached to a ignition coil module.

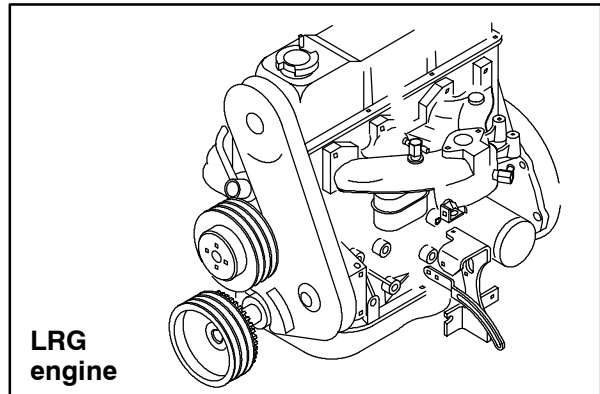
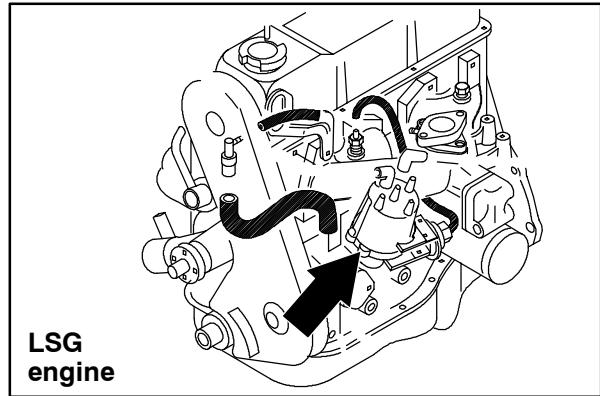

TO REMOVE ENGINE

FOR SAFETY: Before Leaving Or Servicing Machine; Stop On Level Surface, Set Parking Brake., Turn Off Machine And Remove Key.

1. Remove the engine cover and side door.
2. Remove the battery cables from the battery.
3. Drain the fluid from the radiator.
4. Drain the engine oil.
5. Remove the air cleaner assembly.
6. Remove the radiator hoses from the engine.
7. Disconnect the exhaust pipe at the engine manifold.
8. Disconnect the wire harness from all of the engine components and position it out of the way.
9. Disconnect the engine ground strap from the machine frame.
10. Disconnect the fuel line from the tank at the fuel pump on a gas machine. On LPG machine, disconnect the line from the LP tank at the fuel lock off / vaporizer.
11. Remove the two M12 hex screws holding the propel pump to the flywheel housing.
12. Pull the propel pump out of the flywheel coupling.
13. Using overhead hoist, hook a chain through the two pick-up points on top of the engine. Apply a slight amount of tension on the chain.
14. Remove the two M12 hex screws from the front motor mounts. These are the vertical ones coming through the rubber isolators.
15. Remove the two M10 hex screws from the rear motor mount. These are the horizontal ones holding the motor mount bracket to the back of the bellhousing plate.
16. The engine can now be carefully lifted out.

NOTE: Be sure to disconnect engine oil drain hose from oil pan before lifting engine completely out of machine.

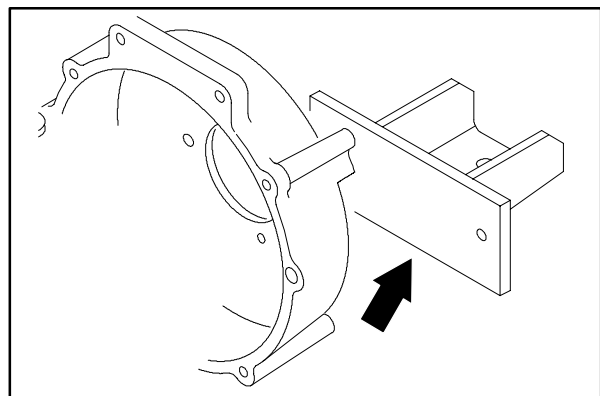
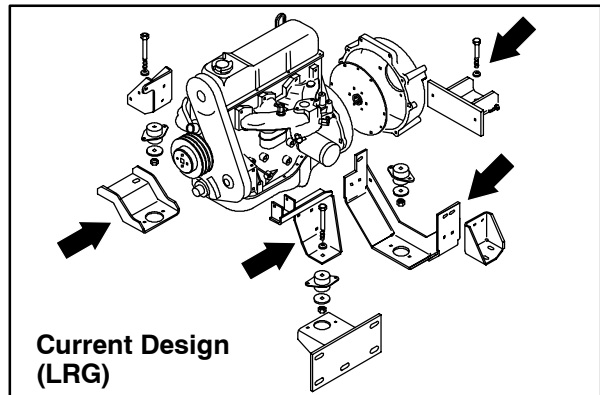
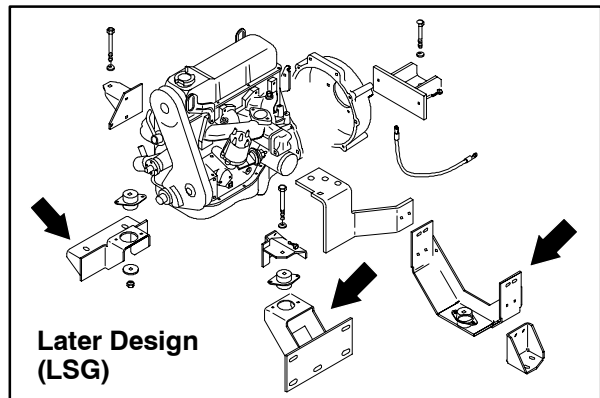
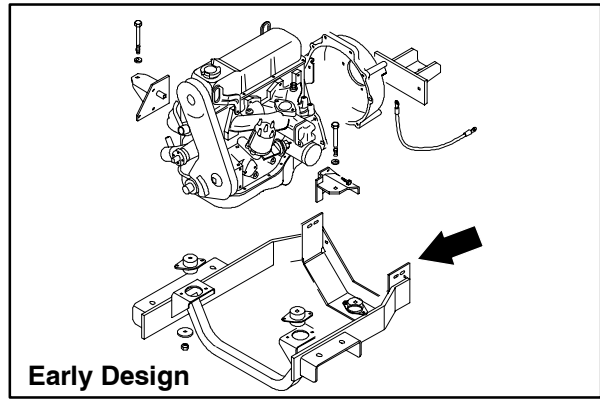

TO INSTALL ENGINE

FOR SAFETY: Before Leaving Or Servicing Machine; Stop On Level Surface, Set Parking Brake., Turn Off Machine And Remove Key.

1. Using an overhead hoist, hook a chain through the two pick-up points on the top of the engine. Position the engine into engine compartment.
2. Carefully lower the engine assembly down on the motor mounts.

NOTE: Make sure the hoses, wire harness, exhaust pipe and propel pump are pulled back out of the way when lowering engine assembly in place.

3. Reinstall the two M12 hex screws in the front motor mounts. Tighten to 64 - 83 Nm (47 - 61 ft lb).
4. Reinstall the rear motor mount on the bellhousing plate using two M10 hex screws. Tighten to 37 - 48 Nm (26 - 34 ft lb).
5. Reinstall the propel pump back in the bellhousing. Reuse the M12 hex screws. Tighten to 64 - 83 Nm (47 - 61 ft lb).

NOTE: Make sure the splines on pump line up with splines in coupler when installing pump.

6. Reinstall the exhaust pipe back on the manifold using the four M10 hex screws. Tighten to 52 - 67 Nm (39 - 50 ft lb).

NOTE: Make sure the steel gasket is in place when installing exhaust pipe.

7. Reconnect the fuel lines.
8. Reconnect the ground cable from the bellhousing to the machine frame.

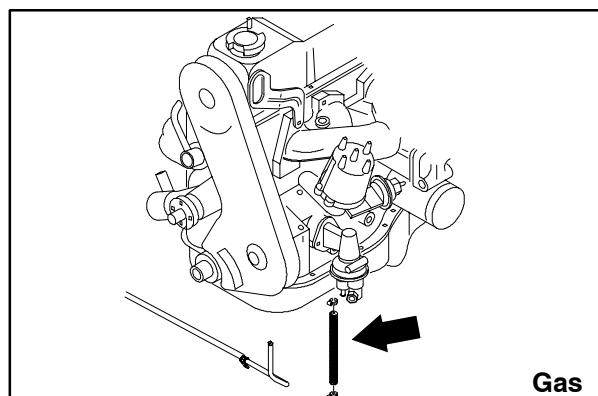
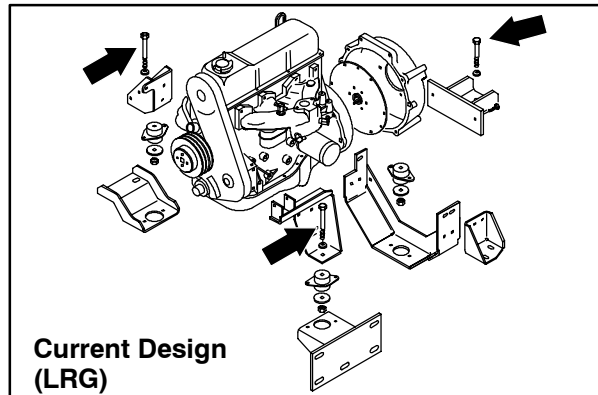
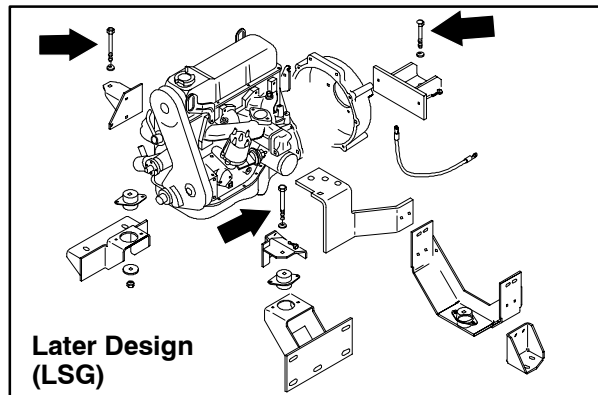
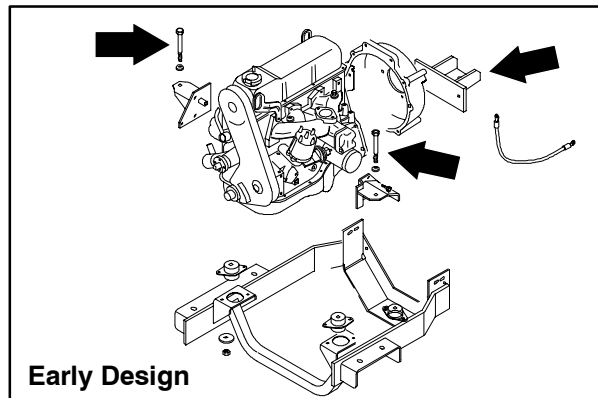

ENGINE-G/LPG

9. Reconnect the oil drain hose to oil pan and fill the engine with the proper grade of engine oil.
10. Reconnect the main wire harness to engine components: alternator, starter, governor actuator, oil switch, temperature sender, distributor, and ignition module.
11. Reinstall the radiator hoses to engine and fill the radiator with anti-freeze coolant.
12. Reinstall the air cleaner assembly.
13. Reconnect the battery cables.
14. Jack up the rear of the machine.

FOR SAFETY: Block machine tires before jacking machine up. Jack machine up at designated locations only. Block machine up with jack stands

15. Start the engine. Check for leaks on the fuel lines and hydraulic lines.
16. Reinstall the engine cover and side door. Lower the machine and operate, checking for proper operation.

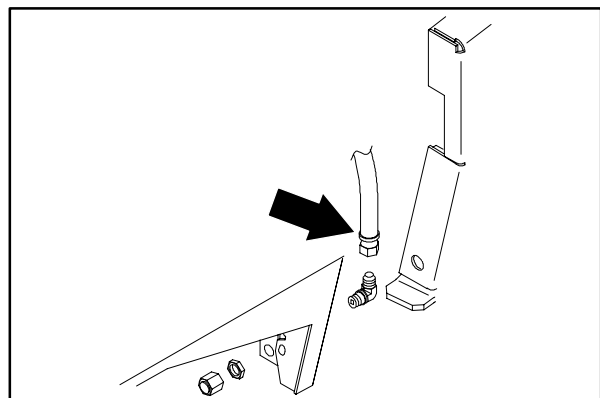
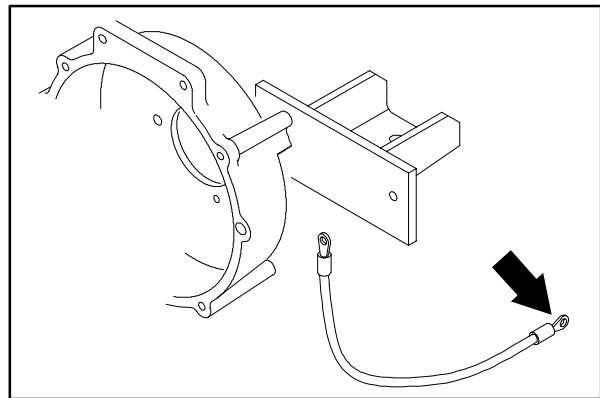
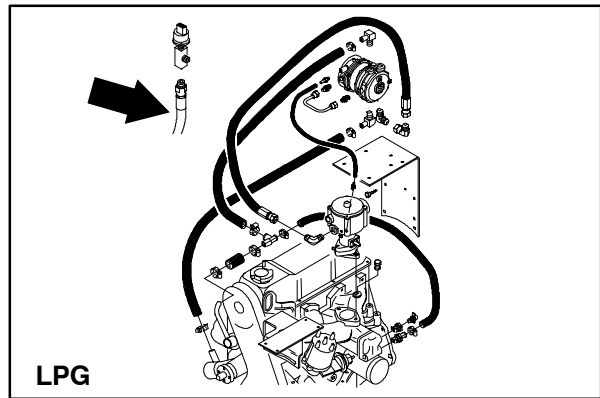

TO CHANGE ENGINE TIMING BELT

FOR SAFETY: Before Leaving Or Servicing Machine; Stop On Level Surface, Set Parking Brake. Turn Off Machine And Remove Key.

1. Disconnect the battery cables from machine.
2. Open the engine cover and side door.
3. Remove the engine spark plugs.

NOTE: Make sure the timing pointer on the timing belt cover is lined up with the "O" mark on the crank shaft damper before removing the timing belt.

4. Loosen the engine alternator and remove the V-belt.

NOTE: If the engine is equipped with a smaller top timing belt cover; it needs to be removed before the larger timing belt cover can be removed

5. Remove the three M6 hex screws and nyloc nuts holding the smaller top cover to the engine. Remove and retain the smaller cover.
6. Remove the crankshaft damper pulley.
7. Pull the belt guide off the end of the crankshaft where the damper was removed.
8. Remove the five hex screws holding the large timing belt cover to the engine. Remove and retain the large cover.

NOTE: The tension on the timing belt needs to be released before the belt can be removed.

9. Loosen the belt tensioner adjustment screw and release the tension on the timing belt. Once the tension is released, re-tighten the tensioner adjustment screw.

NOTE: A special tension release tool is available from FORD. The part number is T74P-6254-A. A small pry bar may be used in place of this tool.

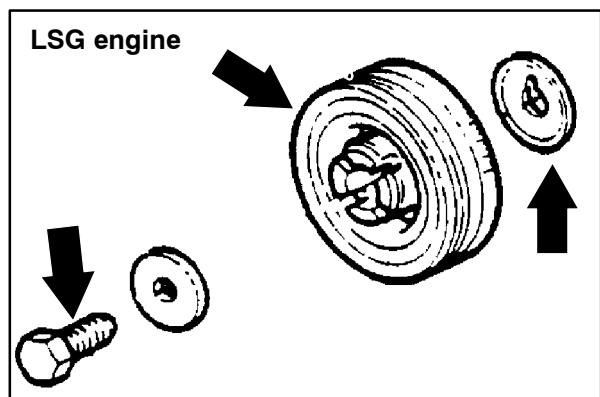
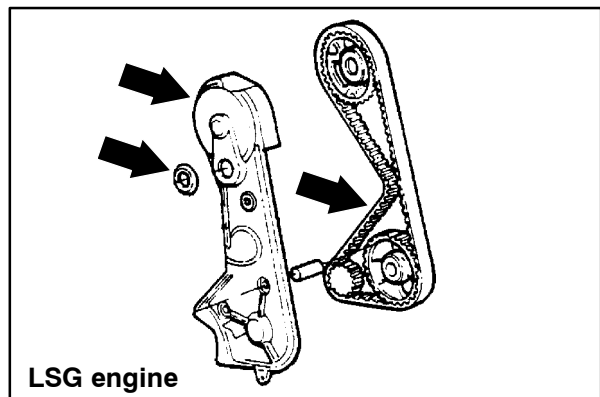
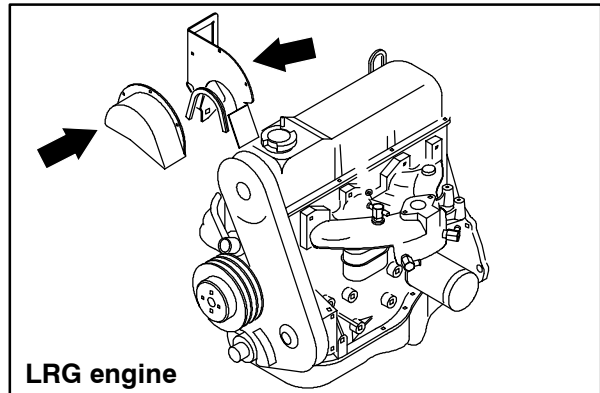
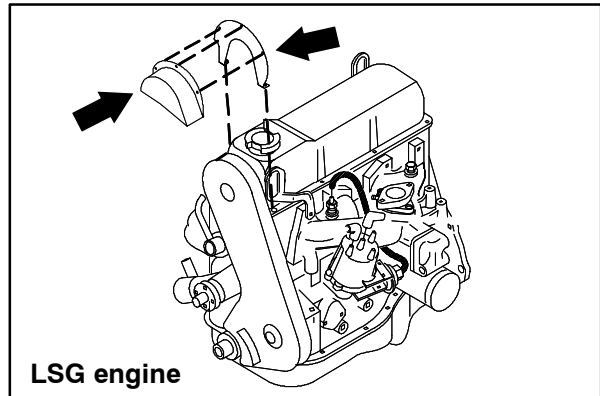

ENGINE-G/LPG

10. Remove the old timing belt from the engine.
11. Before installing a new timing belt, make sure the camshaft sprocket timing mark lines up with the timing pointer on the engine.
12. **(LSG only)** Remove the distributor cap and set the distributor rotor to number 1 firing position by turning the auxiliary shaft sprocket. Reinstall the distributor cap.
13. Install the new timing belt over the crankshaft sprocket and then counterclockwise over the the auxiliary and camshaft sprockets. Align the belt fore and aft on each sprocket.
14. Loosen the tensioner adjustment bolt to allow the tensioner to move against the belt.
15. Rotate the crankshaft two complete turns in normal rotation to remove the slack from the belt.
16. Re-check the alignment of the timing marks.
17. Reinstall the belt guide and damper to the crankshaft.
18. Reinstall the timing belt cover and the five hex screws.
19. Reinstall the small, top cover on the timing belt cover. Hand tighten the three M6 hex screws and nyloc nuts.
20. Reinstall the spark plugs.
21. Reinstall the alternator V-belt, pull the alternator to tension the belt, tighten the alternator mount bolts.
22. Reconnect the battery cables. Start the engine and check the timing. The timing should be set at 10 degrees BTDC with the engine at idle speed.

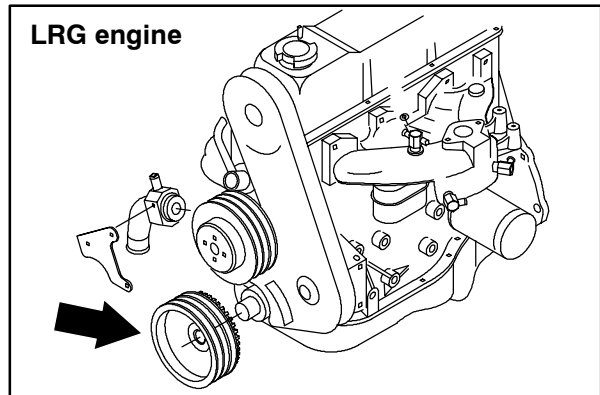
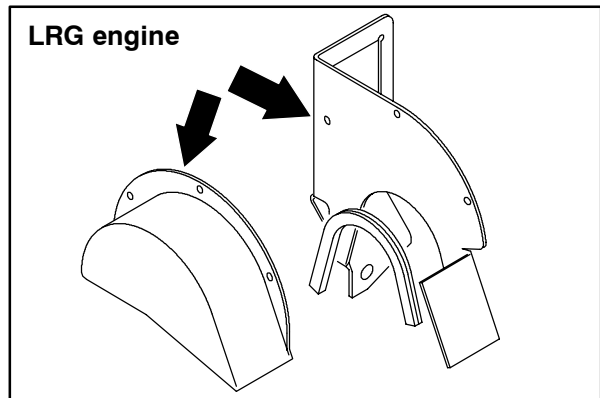
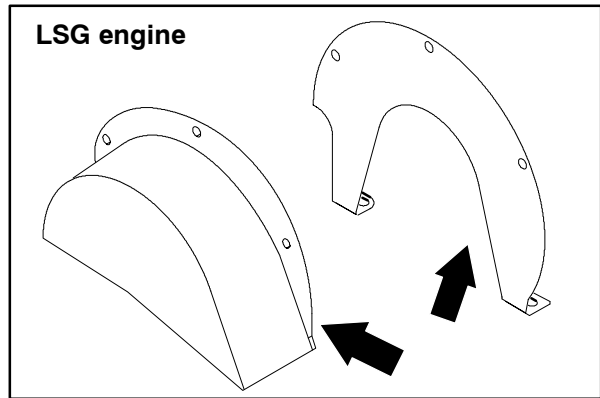

LUBRICATION

ENGINE

Check the engine oil level daily. Change the engine oil and oil filter every 100 hours of machine operation. Use 10W30 SAE-SG/SH rated engine oil.

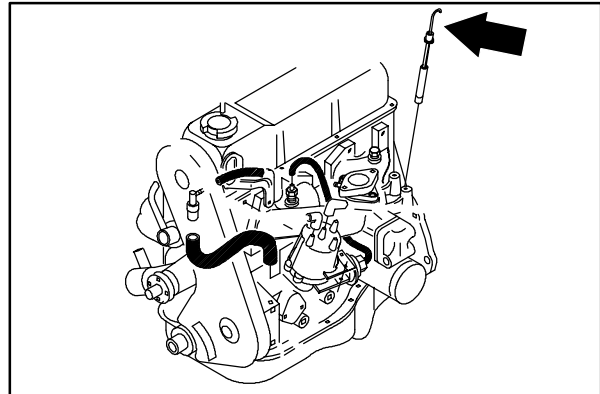

The engine oil drain is located on the left side of the machine inside the main brush compartment.

Fill the engine with oil to the level indicated on the oil dipstick. The engine oil capacity is 4.7 L (5 qt) including the oil filter.

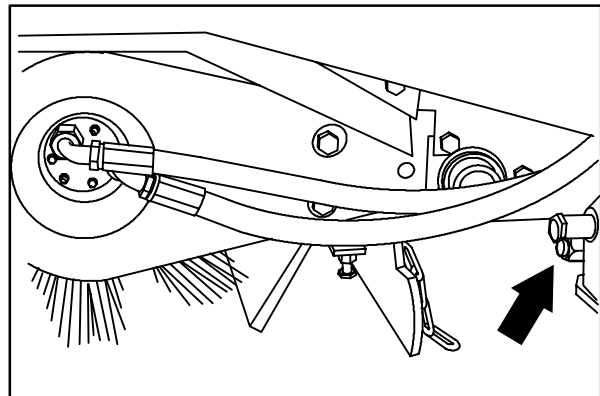

08448

COOLING SYSTEM

Check the radiator coolant every 100 hours of operation. Use clean water mixed with a permanent-type, ethylene glycol antifreeze to a -34°C (-30°F) rating.

FOR SAFETY: When Servicing Machine, Avoid Contact With Hot Engine Coolant.

ATTENTION! Never pour cold water or cold antifreeze into the radiator of an overheated engine. Allow the engine to cool down to avoid cracking the cylinder head or block. Keep the engine running while adding water.

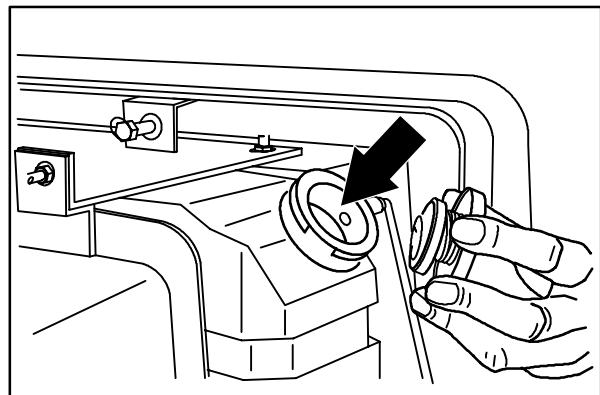

08432

ENGINE-G/LPG

Clean the radiator screen every 100 hours of operation.

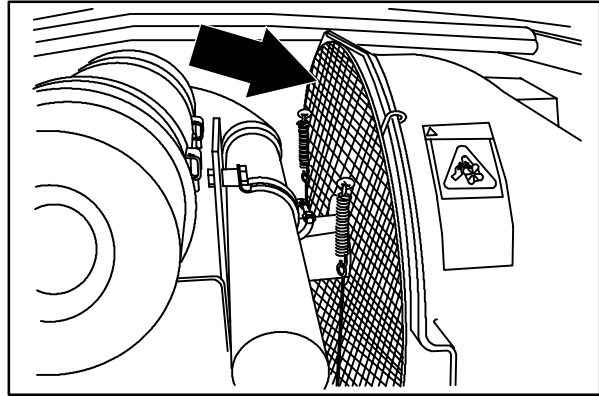

08582

Check the radiator hoses and clamps every 200 hours of operation. Tighten the clamps if they are loose. Replace the hoses and clamps if the hoses are cracked, harden, or swollen.

Check the radiator core exterior and hydraulic cooler fins for debris every 100 hours of operation. Blow or rinse all dust, which may have collected on the radiator, in through the grille and radiator fins, opposite the direction of normal air flow. The grille and hydraulic cooler open for easier cleaning. Be careful not to bend the cooling fins when cleaning. Clean thoroughly to prevent the fins becoming encrusted with dust. Clean the radiator and cooler only after the radiator has cooled to avoid cracking.

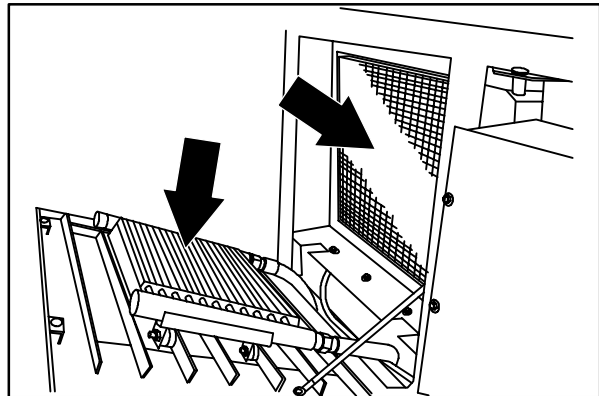

08454

FOR SAFETY: When Servicing Machine, Wear Eye And Ear Protection When Using Pressurized Air Or Water.

Flush the radiator and the cooling system every 400 hours of operation, using a dependable cleaning compound.

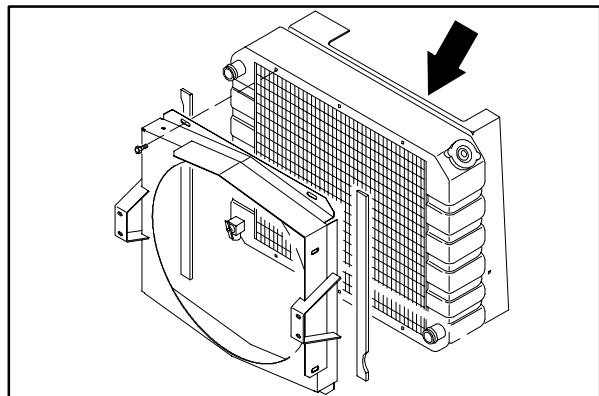

ENGINE BELT

The engine fan belt is driven by the engine crankshaft pulley and drives the alternator pulley. Proper belt tension is 9 to 10 mm (0.35 to 0.39 in) for a new belt and 10 to 11 mm (0.39 to 0.43 in) for a used belt with a force of 10 kg (22 lb).

Check and adjust the belt tension every 100 hours of operation.

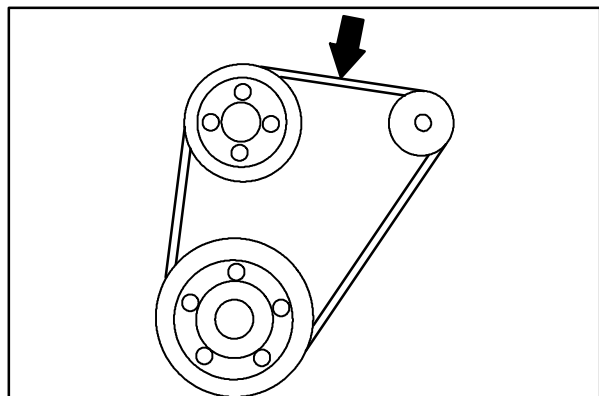

08486

AIR INTAKE SYSTEM

AIR FILTER INDICATOR

The air filter indicator shows when to clean or replace the air filter element. Check the indicator daily. The indicator's red line will move as the air filter element fills with dirt. Do not clean or replace the air filter element until the red line reaches 5 kPa (20 in H₂O) and the "SERVICE WHEN RED" window is filled with red. The indicator's red line may return to a lower reading on the scale when the engine shuts off. The red line will return to a correct reading after the engine runs for a while.

Reset the air filter indicator by pushing the reset button on the end of the indicator after cleaning or replacing the air filter element.

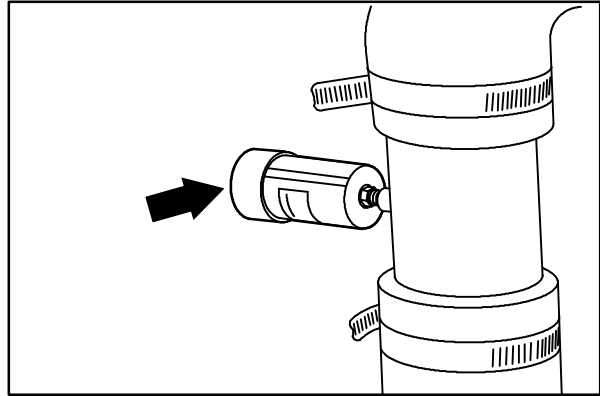

08447

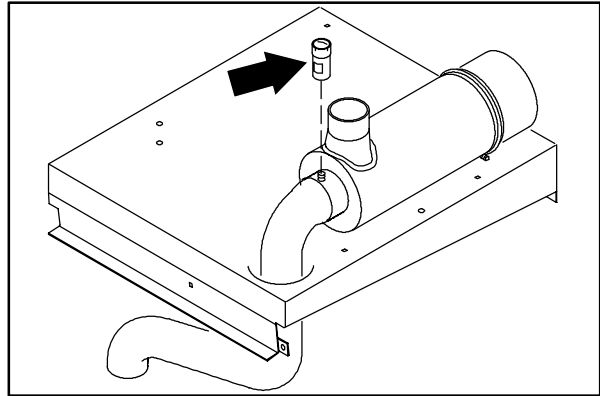

AIR FILTER

The engine air filter housing has a dust cap and a dry cartridge-type air filter element. Empty the dust cap daily. The air filter must be replaced whenever the filter element is damaged or has been cleaned three times.

Service the air filter element only when the air filter indicator shows restriction in the air intake system. Do not remove the air filter element from the housing unless it is restricting air flow.

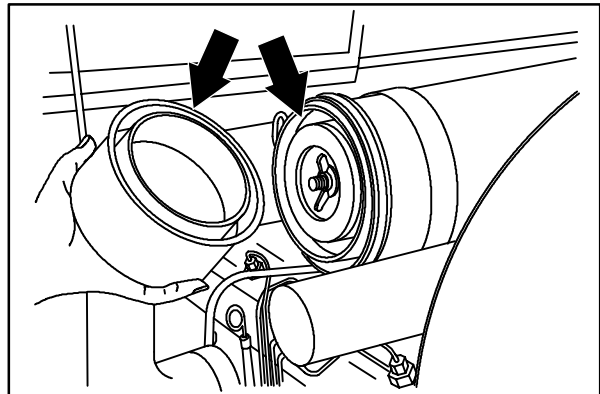

08455

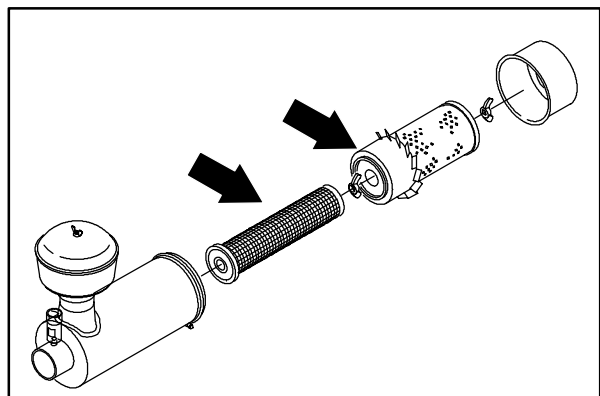

TO REPLACE AIR FILTER ELEMENT

1. Stop the engine and set the machine parking brake.

FOR SAFETY: Before Leaving Or Servicing Machine: Stop On Level Surface, Set The Parking Brake, Turn Off Machine And Remove Key.

2. Open the left side and top engine access doors.
3. Unscrew the clamp ring on the filter.
4. Remove the dust cap.
5. Empty the dust cap.
6. Remove the filter wing nut.
7. Gently pull the filter element out of the filter housing.
8. Clean the interior of the air cleaner housing with a damp cloth. Clean the element housing sealing surfaces.
9. Using an air hose, direct dry, clean air maximum 205 kPa (30 psi) up and down pleats on the inside of the filter. Do not rap, tap, or pound dust out of the element.

FOR SAFETY: When Servicing Machine, Wear Eye And Ear Protection When Using Pressurized Air Or Water.

10. After cleaning the air filter element, inspect it for damage by placing a bright light inside. The slightest rupture requires replacement of the filter. Clean and inspect the seals on the ends of the element. They should be unbroken and flexible. Remember to replace the element after cleaning it three times.
11. Install the new or cleaned filter element so the fins on the element are at the intake end of the air cleaner. Be careful not to damage the fins. Make sure the element is seating evenly. Tighten the element wing nut.
12. Install the dust cap with the arrows pointing up. Tighten the clamp ring to hold it in place. Check all intake hose connections for leaks or abrasions.
13. Reset the air filter restriction indicator.
14. Close the access doors.

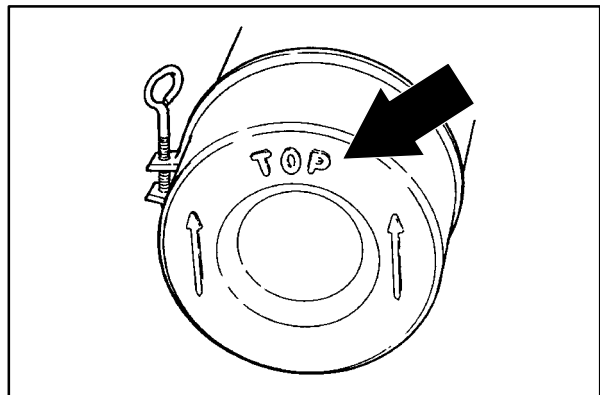
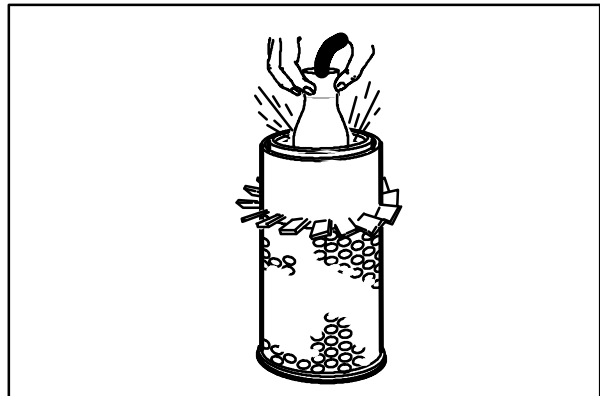
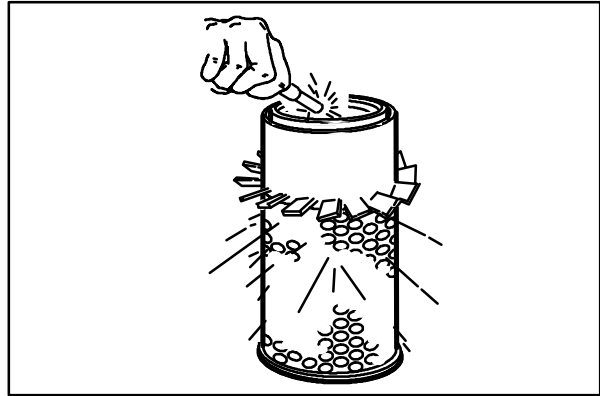

02492

FUEL SYSTEM - GASOLINE

FUEL FILTERS

The fuel filter traps fuel contaminants. The filter is located on the fuel line going into the carburetor.

Replace the filter elements every 400 hours of operation.

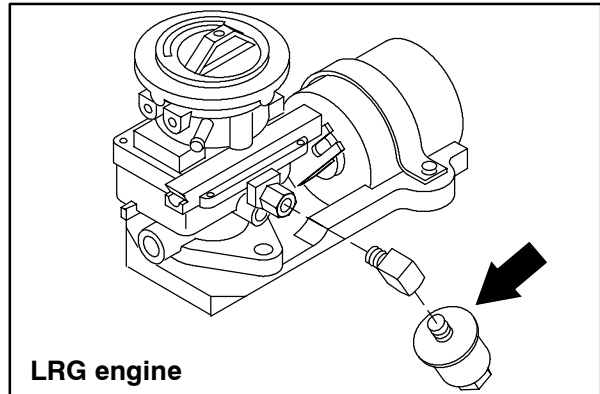
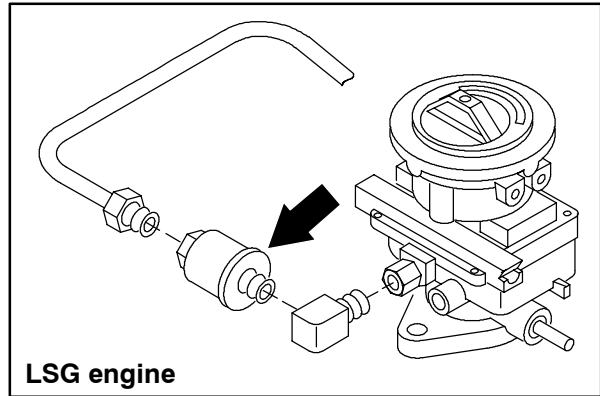

CARBURETOR

The carburetor has two basic adjustments. Those adjustments are idle fuel mixture and idle speed. Check and adjust idle fuel mixture and idle speed every 100 hours of operation.

FOR SAFETY: When Servicing Machine, Keep Flames And Sparks Away From Fuel System Service Area. Keep Area Well Ventilated.

The idle speed is controlled by a screw located on the side of the carburetor next to the throttle linkage. Increase the engine speed by turning the screw clockwise. Decrease the engine speed by turning the screw counter-clockwise. Proper idle speed is 950 ± 50 rpm with all accessories off.

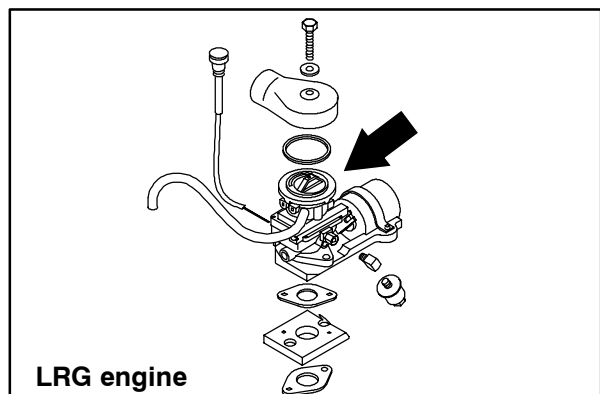
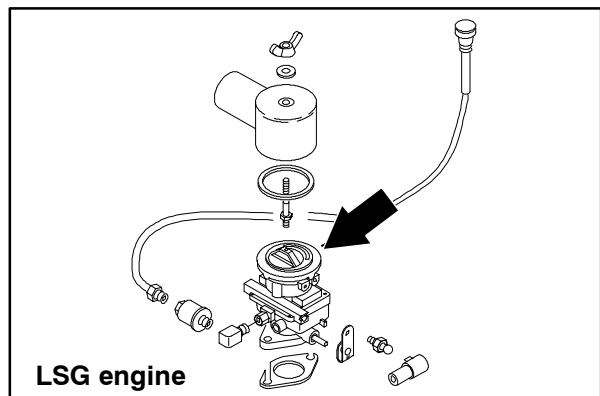

FUEL SYSTEM - LPG

The liquid withdrawal LPG fuel system has up of five components: the LPG fuel tank, pressure relief valve, fuel filter lock, vaporizer-regulator, and the carburetor.

Liquid LPG fuel flows from the LPG tank under its own pressure, to the pressure relief valve. Usually this valve is closed, preventing LPG fuel from escaping into the atmosphere. The valve opens to relieve pressure if the fuel pressure exceeds system limits. From the pressure relief valve, the liquid LPG fuel flows to the fuel filter lock.

The fuel filter lock filters unwanted tank scale and deposits out of the LPG fuel. The fuel filter lock also stops the flow of LPG fuel when the engine is not operating. The filter fuel lock allows LP fuel to flow to the carburetor when engine vacuum is sensed.

The vaporizer section of the vaporizer-regulator converts the liquid LPG fuel into a gaseous LPG fuel. From the vaporizer section, the gaseous LPG fuel is sent to the primary regulator section of the vaporizer-regulator. The primary regulator section reduces the pressure of the LPG fuel. The secondary regulator section reduces the LPG fuel pressure to the level required by the carburetor. From the vaporizer-regulator, the LPG fuel is sent to the carburetor where it is finally metered into the air flow sent to the engine combustion chamber.

Never operate an LPG powered machine if the LPG fuel system is leaking, or if any component in the fuel system is malfunctioning. Operating the machine under either of these conditions may cause a fire or explosion.

Check for frosting. If frosting occurs on or near any LPG component, there is a possible LPG fuel leak or malfunctioning component.

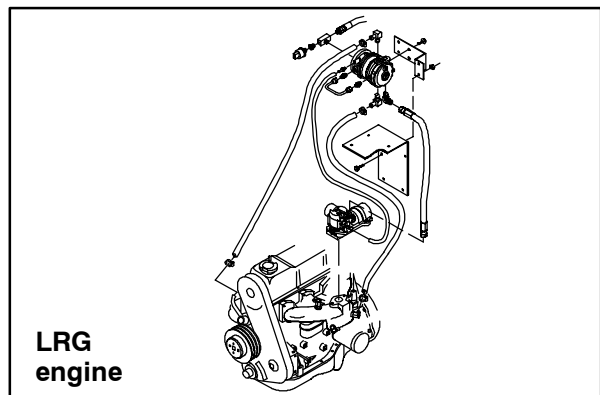
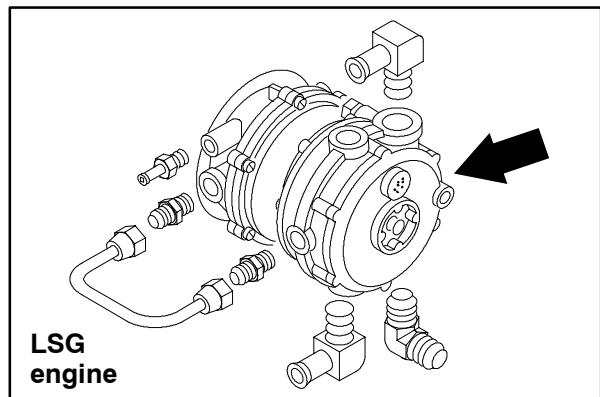
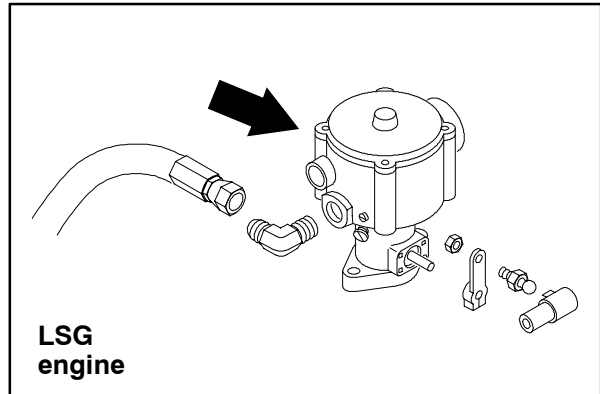
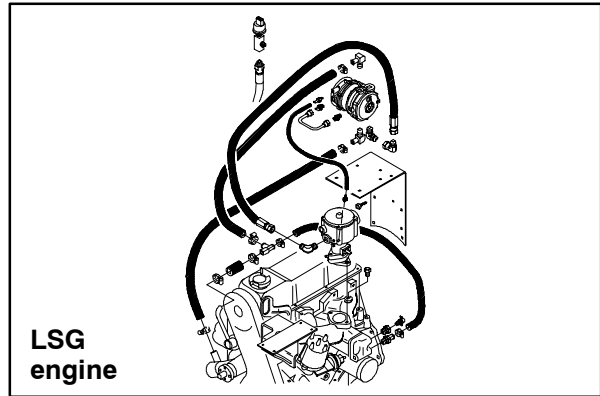

To locate the leak, apply a soapy water solution to the suspected area. Watch for bubbles forming in this suspected area. This area may have an LPG fuel leak. Repair or replace the part. Use Loctite brand Stainless Steel PST thread sealant when reassembling. Aging or high humidity does not affect this epoxy-type sealant. Be sure to follow application directions and apply proper torque when reconnecting fittings. Never bypass safety components except to test. If they are defective, replace them before operating the machine. Frosting does not occur before the engine reaches operating temperature. Check after engine reaches operating temperature.

Check routings of all LPG hoses. Keep them away from sharp edges, exhaust manifolds, or other hot surfaces. Check for signs of abrasion or deterioration. Replace worn or damaged hoses.

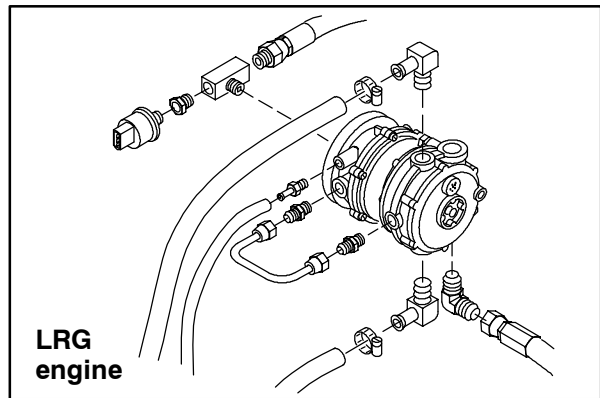
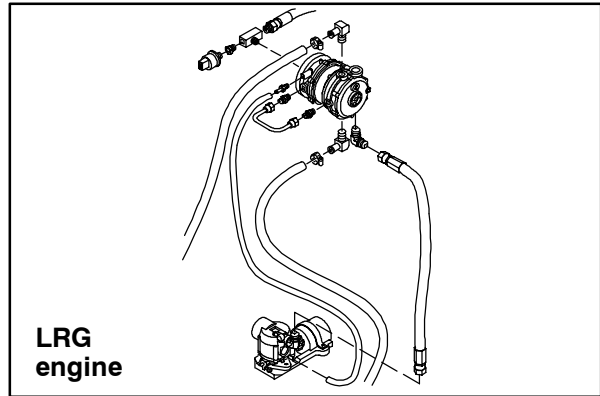

LPG FUEL TANK

The LPG fuel tank should be inspected for sharp dents, gouges, leaks, and broken protecting rings whenever the tanks are refilled. All tank valves must be inspected for leaks using a soap solution. Valves must also be checked for dirt, paint, or other debris in the valve openings. The following specific checks must also be made:

Filler Valve - Check the valve for proper functioning and the presence of the handwheel. Valve must be closed except during filling.

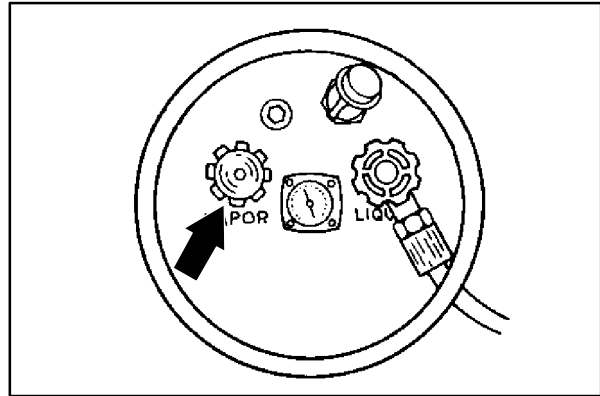

03485

Liquid Service Valves - Check the valve for proper functioning and presence of the handwheel. The valve must be closed except when in service.

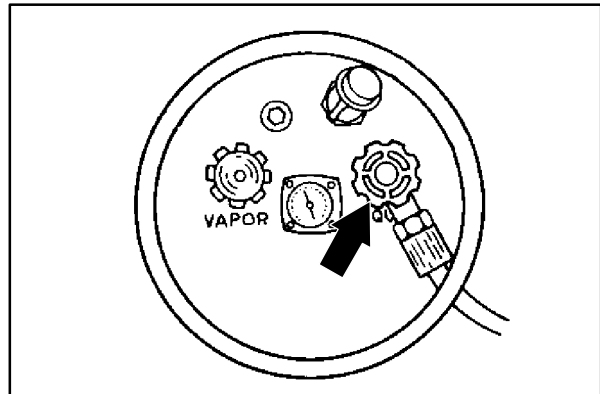

03485

Tank Service Valve Coupling - Check for proper functioning, thread condition, and damaged or missing washers or o-rings.

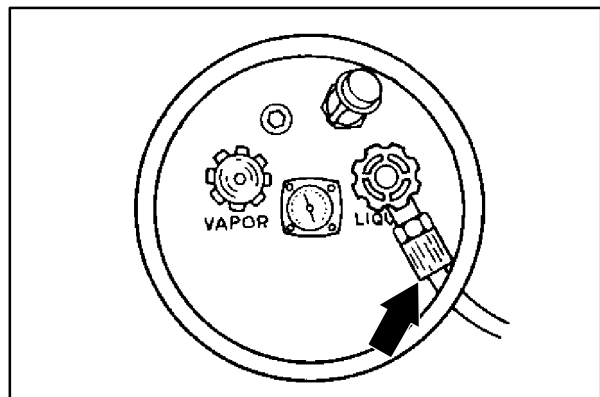

03485

Safety Relief Valve – Check for damage. Check for the presence of the relief valve elbow and the proper direction of the elbow. If the rain cap is missing, check for foreign matter and replace the rain cap. Do not tamper with the relief valve setting.

Magnetic Liquid Level Gauge – Check the operation against the maximum filling point as determined by weight.

An LPG fuel tank with any of the stated defects must be removed from service and be repaired or destroyed accordingly.

If an LPG fuel tank is damaged or leaking, it should be removed to a designated safe area. Do not attempt to make repairs to the tank, regardless of condition. Qualified personnel must make repairs or disposal.

The care an LPG fuel tank receives has a direct bearing on how long that tank can be used safely. LPG fuel tanks must not be dropped or dragged across any surface. To move LPG fuel tanks, use a hand truck or roll the tank on its foot ring while it is being held in a position slightly off the vertical.

Whether the storage is inside or outside, fuel tanks should not be stored near combustible materials or high temperature sources such as ovens and furnaces, since the heat may raise the pressure of the fuel to a point where the safety relief valves would function. Store the tanks in a way that if the safety relief valves do function, they will relieve vapor and not liquid.

Valves on empty tanks must be closed during storage and transportation.

Similar precautions should be taken in storing machines fitted with LPG fuel tanks. The machines may be stored or serviced inside buildings, provided there are no leaks in the fuel system and the tanks are not overfilled. While machines are being repaired inside a building, the shut-off valve on the tank must be closed, except when the engine has to be operated.

Changing the tank is a chance for the machine operator to carefully check over the tank, fittings, and the fuel lines and fittings. If abnormal wear is detected, report the findings to the appropriate personnel.

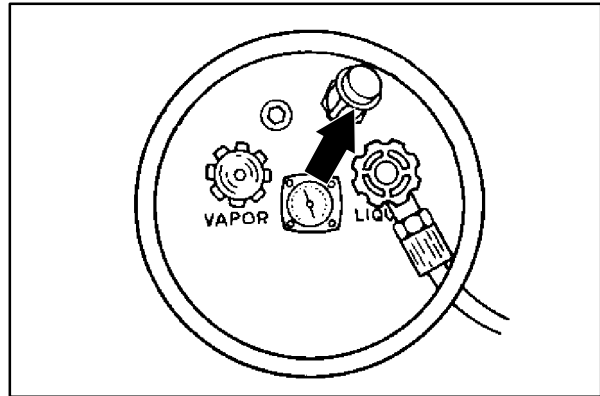

03485

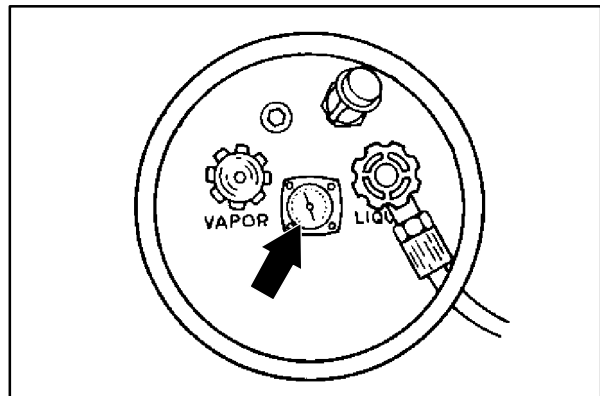

03485

TO CHANGE LPG FUEL TANK

FOR SAFETY: Before Leaving Or Servicing Machine; Stop On Level Surface, Set Parking Brake., Turn Off Machine And Remove Key.

1. Park the machine in a designated safe area.
2. Close the tank service valve.
3. Operate the engine until it stops from lack of fuel, then set the machine parking brake.
4. Put on gloves and remove the quick-disconnect tank coupling.
5. Inspect the LPG fuel lines for wear or damage.
6. Remove the empty LPG fuel tank from the machine.
7. Check the tank for damage or wear.
8. Store the tank in a designated, safe area.
9. Select a filled LPG fuel tank and inspect it for damage or leaks.

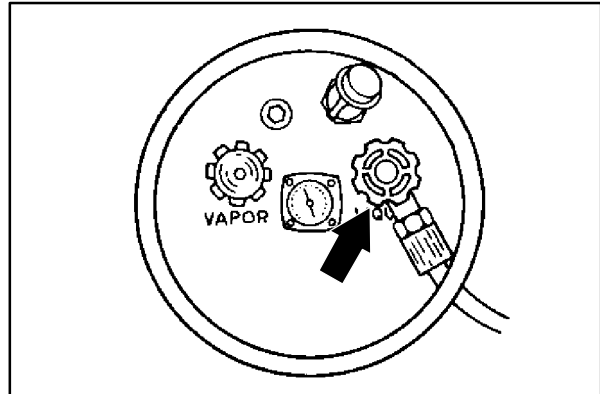

03485

NOTE: Make sure the LPG fuel tank matches the fuel system (liquid tank with liquid system).

10. Carefully put the LPG tank in the machine so that the tank centering pin enters the aligning hole in the tank collar.

NOTE: If you cannot line up the centering pin, make sure you have the correct LPG fuel tank and then adjust the pin locator in or out.

11. Fasten the tank hold-down clamp to lock the tank in position.
12. Connect the LPG fuel line to the tank service coupling. Make sure the service coupling is clean and free of damage. Also make sure it matches the machine service coupling.
13. Open the tank service valve slowly and check for leaks. Close the service valve immediately if an LPG leak is found, and tell the appropriate personnel.
14. If no leaks are found, the engine is ready to start.

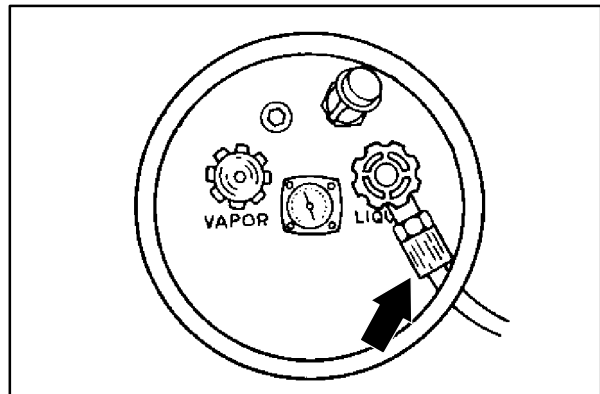

03485

FUEL FILTER LOCK

The fuel filter lock filters the LPG fuel. It also stops the flow of LPG fuel to the engine when the engine is not operating or when the engine vacuum drops to zero.

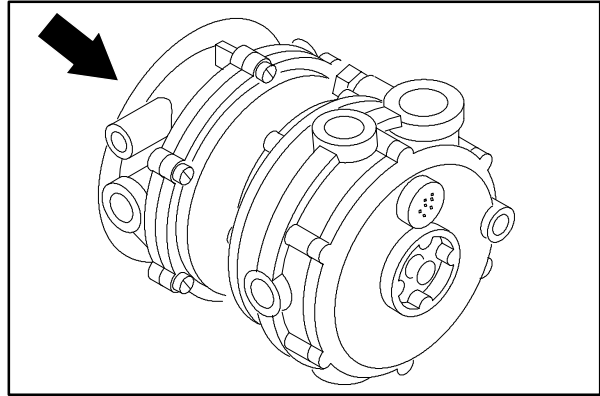
**VAPORIZER-REGULATOR**

If any malfunction is found, completely disassemble the vaporizer-regulator. Clean all the parts in alcohol.

Inspect all the parts and replace where needed. Carefully reassemble the vaporizer-regulator with the seal repair kit. Check for proper operation.

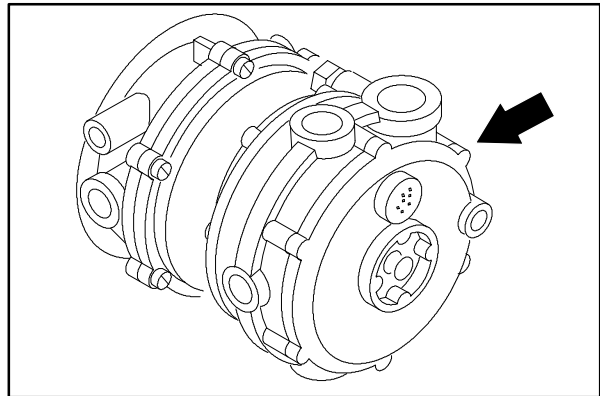
**CARBURETOR**

If any malfunction is found, completely disassemble the carburetor. Clean all the parts in alcohol.

Inspect all the parts and replace where needed. Carefully reassemble the carburetor with the seal repair kit.

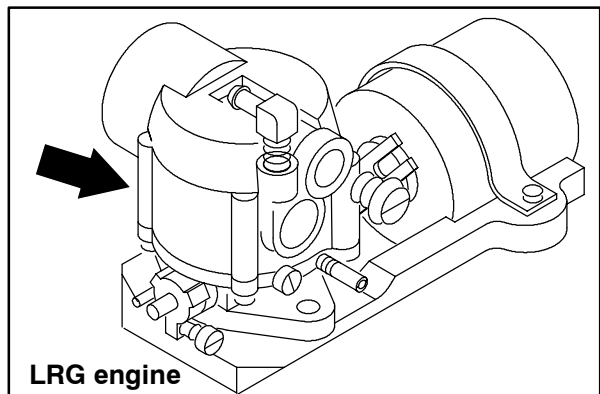
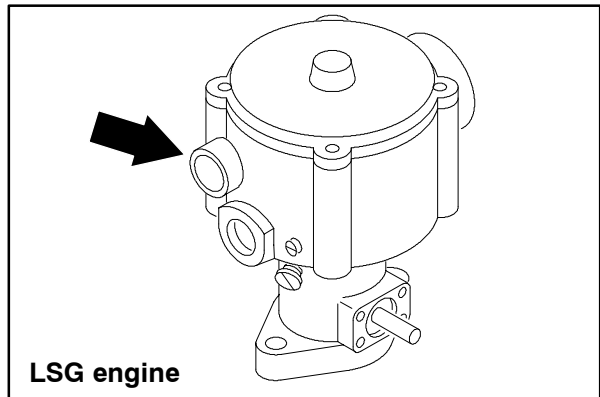

ENGINE-G/LPG

OIL PRESSURE SWITCH

The engine oil pressure switch requires no regular maintenance. Never bypass the oil pressure switch. The switch is a safety feature that prevents the engine from starting until there is oil pressure. The switch will also shut the engine off if there is a loss of oil pressure.

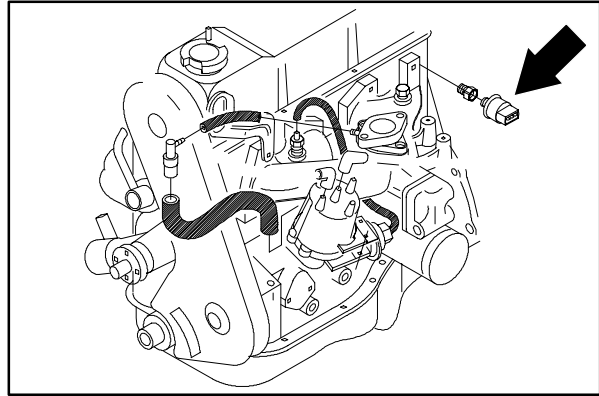

LPG FUEL TROUBLESHOOTING

Problem	Cause	Remedy
<i>Engine will not start</i>	Out of fuel	Fill fuel tank
	Service valve opened too quickly - check valve stopped fuel flow	Close service valve and reopen slowly
	Plugged fuel filter	Replace filter
	Kinked or restricted fuel line	Straighten or replace fuel line
	Engine out of tune	Tune-up engine
	Oil pressure switch failure	Replace oil pressure switch
	Fuel lock valve failure	Repair or replace fuel filter lock
	Vaporizer-regulator failure	Repair or replace vaporizer-regulator
<i>Engine runs unevenly or lacks power</i>	Wrong type of fuel tank - vapor withdrawal tank	Replace vapor withdrawal tank with liquid withdrawal tank
	Plugged fuel filter	Replace filter
	Kinked or restricted fuel line	Straighten or replace fuel line
	Engine out of tune	Tune-up engine
	Restricted air filter	Clean or replace air filter element
	Vaporizer-regulator out of adjustment	Adjust vaporizer-regulator

GOVERNOR ACTUATOR (LSG ENGINE)

The electronic governor controls the engine speed. The governor consists of an ignition control assembly, a control box, and an actuator mounted to the carburetor. The ignition control assembly and control box regulate the actuator, which in turn controls the throttle.

The electronic governor is factory set and is not user serviceable.

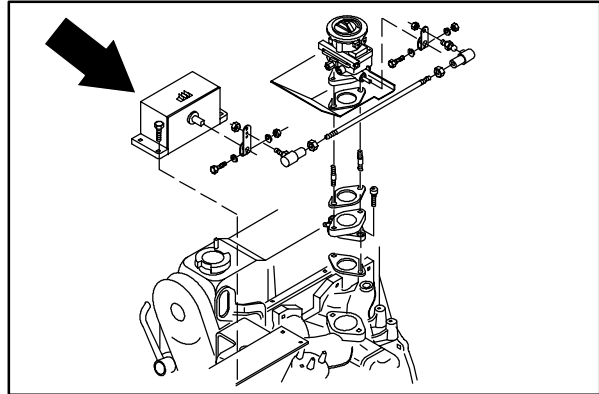

TO REPLACE GOVERNOR ACTUATOR (LSG ENGINE)

FOR SAFETY: Before Leaving Or Servicing Machine; Stop On Level Surface, Set Parking Brake., Turn Off Machine And Remove Key.

1. Stop the engine and set the machine parking brake.
2. Open the engine cover and side door.
3. Disconnect the battery cables.

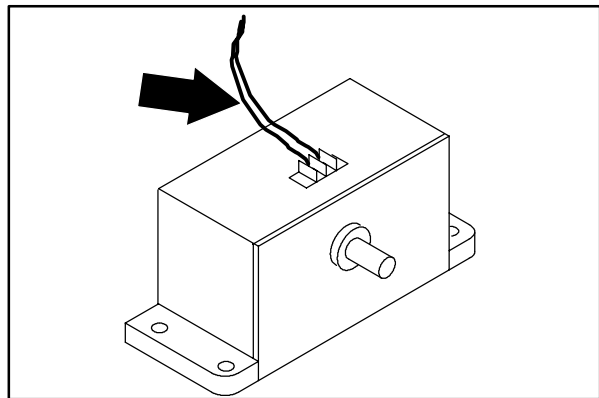

⚠ WARNING: Always disconnect battery cables from machine before working on electrical components.

4. Disconnect the two wires leading to the top of the governor actuator.
5. Pop the rod end of the throttle rod off the ball on the actuator arm.
6. Remove the four screws and nuts holding the actuator to the mount bracket.
7. Remove the arm from the actuator shaft and install it on the new actuator in the same orientation.
8. Position the new actuator on the mount bracket and install the four screws and nuts. Tighten to 9 - 13 Nm (7 - 10 ft lb).
9. Snap the throttle rod onto the ball on the actuator arm.
10. Reconnect the two wires on top of the actuator. Reconnect the battery cables.
11. Start the machine and check the new actuator for proper operation. See TO ADJUST GOVERNOR instructions.

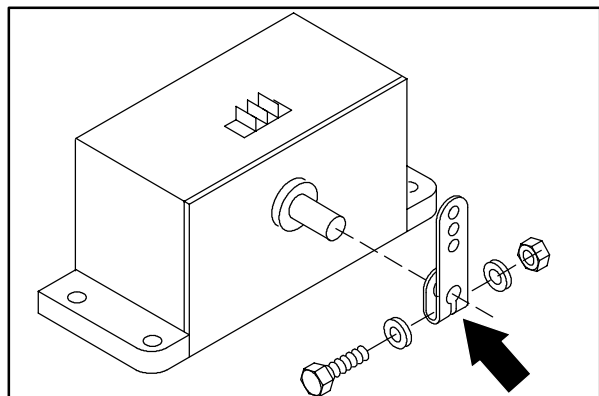
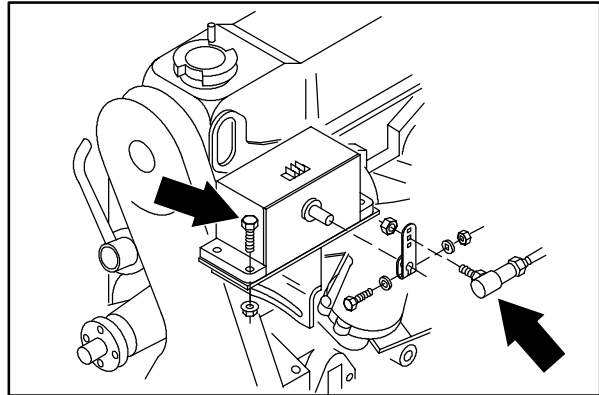

TO ADJUST GOVERNOR (LSG ENGINE)

FOR SAFETY: Before Leaving Or Servicing Machine: Stop On Level Surface, Set The Parking Brake.

1. Raise the rear of the machine until the drive wheel is off the floor.

FOR SAFETY: Block machine tires before jacking machine up. Jack machine up at designated locations only. Block machine up with jack stands.

2. Start the engine and warm to operating temperature.
3. Move the speed switch to idle, all accessories off.
4. Move speed switch to fast position.
5. If more than three engine speed surges occur, turn the surge adjustment screw (located on back of governor control box under hole plug) counterclockwise one-eighth of a turn.
6. Repeat this procedure until less than three engine surges occur.
7. Replace the hole plug if removed for adjustment.

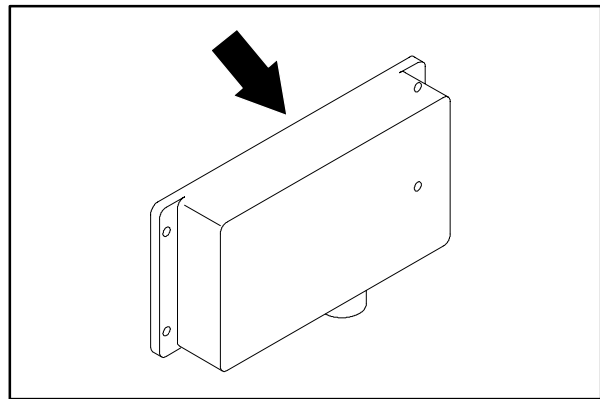
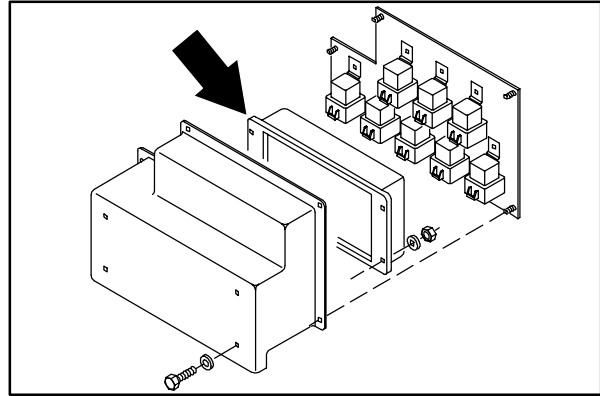

GOVERNOR TROUBLESHOOTING (LSG ENGINE)

1. The first step in this troubleshooting is to disconnect the throttle linkage at the carburetor and work the throttle at the carburetor by hand.

If you can run the engine by hand and it works with no problems, go to step two.

If the problem continues, it is not with the governor, it is with the ignition signal, fuel systems or the engine itself.

2. The idle speed is the governor position. This is 1100 – 1500 RPM and is controlled by the governor, NOT THE IDLE STOP SCREW ON THE CARBURETOR! In order to adjust the idle mixture and (SHUTOFF SPEED) on the carburetor, either of the wires on the actuator box must be disconnected. After warming up the engine, adjust the shutoff speed to 850 ± 25 RPM and adjust the idle mixture for optimum idle quality. After doing this, shut off the engine and reattach the wires to the actuator. It is important that the shutoff speed not be set any higher than 900 RPM or the engine will (diesel) when it is shut off. Again, the idle speed screw on the carburetor does not control the start/idle speed of a correctly setup engine.

3. Fuel System

A common problem that has been encountered on LPG machines is a restricted fuel hose (a clogged fuel filter can have the same effect).

If the governor opens the carburetor wide open and the engine loses speed, the problem is not in the governor. The fuel system is at fault. The purpose of the governor is to open the carburetor and to bring the engine to set RPM's depending on where you have the speed control switch set at.

4. System Grounds

The wire harness grounds are routed to the stud on the alternator, and from there, a separate cable is routed to the bolt on the bell housing where the battery cable is attached.

If a bad ground is present, the engine will tend to run over speed.

The machine must have good grounds throughout from the battery cable to the control box.

The battery cable must be clean and tight.

The actuator is internally isolated and does not require that the cable be grounded.

5. Start-Up Check

With the throttle switch in the engine start position, turn the ignition switch to the on position. The actuator should cycle the carburetor lever once.

NOTE: A cycle is to move from the off or idle position to the open position and then return to the off or idle position.

If this does not happen, the power wiring to the control box is probably at fault or the control box is faulty. IT IS RARE TO HAVE A FAULTY CONTROL BOX, so proceed with the following voltage checks BEFORE REPLACING IT.

6. Throttle Control Switch Check

If the engine doesn't respond to the throttle switch control:

- a. With the engine running, disconnect Wire 86, purple wire, at the actuator.
- b. Connect a jumper wire from the battery terminal on the starter to the terminal where you removed Wire 86, purple wire, from the actuator.

The engine should come up to operating speed.
If the engine comes up to speed, replace the throttle control switch.

- a. Hunts at running speed with the accessories off.
- b. Responds very sluggishly to switch changes, an adjustment change in the control box may be necessary.

Cut and remove the RTV seal on the back of the box.

A slight adjustment of the sensitivity screw may be necessary to correct the conditions mentioned above. Turn the screw approximately 2° at a time and wait for 30 seconds to verify the change. Be careful. Only a slight change is necessary, and the “pot” can be broken if too much force is used.

After the control throttle response is achieved, verify that the operating speeds are correct and adjust, if necessary. After the speeds are reset, the sensitivity screw may have to be readjusted.

In general, if a new box is being installed, a gasoline-equipped machine may require that the sensitivity be reduced slightly.

When the sensitivity is adjusted, the run speed should not be affected. If the adjustment is too great, the start speed will be affected. Verify that the start speed is correct.

If too much sensitivity is adjusted in, the engine will either hunt in a no load condition or over speed severely when the speed switch is actuated.

The engine speed should not drop off, but you can have the three hunts of the engine.

If, for some reason, the sensitivity adjustment became grossly maladjusted, a good starting point can be obtained by rotating the pot fully counterclockwise and then back clockwise 45°.

After the adjustments are made and verified, reassemble the back plate and reseal the plate with a bead of RTV to keep dust and moisture out of the box.

GOVERNOR ACTUATOR (LRG ENGINE)

The governor actuator on the LRG engine is smaller than on the LSG engine. The throttle rod has been eliminated on this new actuator. The unit is bolted directly to the carb base.

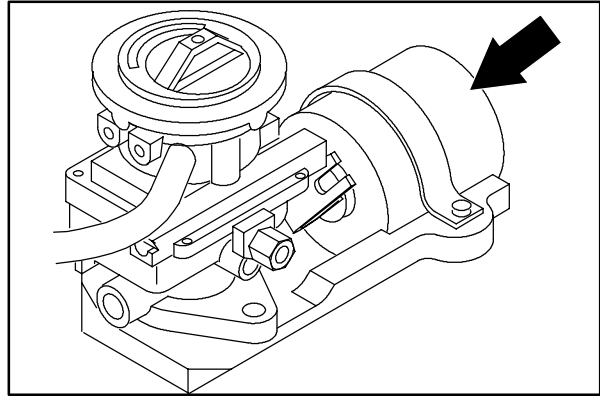

TO REPLACE GOVERNOR ACTUATOR (LRG ENGINE)

FOR SAFETY: Before Leaving Or Servicing Machine; Stop On Level Surface, Set Parking Brake., Turn Off Machine And Remove Key.

1. Stop the engine and set the machine parking brake.
2. Open the engine cover and side door.
3. Unplug the governor actuator from the electrical harness.
4. Remove and retain the cap screw holding the wire clamp to the actuator mount bracket.
5. Remove and retain the two cap screws holding the mounting strap to the mount bracket.
6. Carefully remove the actuator from the mount bracket.

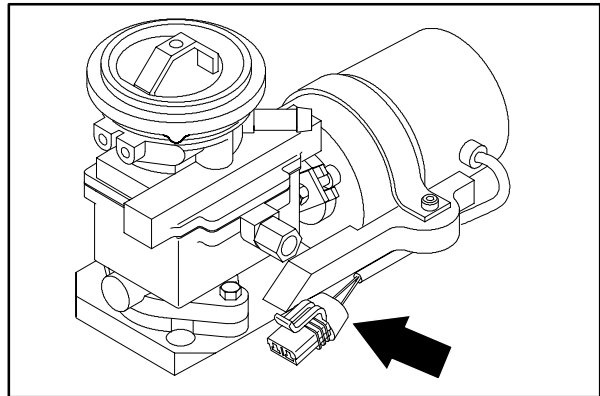

NOTE: When removing the actuator, slip the slotted arm out from the shoulder bolt on the arm of the carburetor.

7. Remove the arm from the old actuator and install on the new actuator in the same orientation.
8. Install the new actuator by sliding the slotted arm under the shoulder bolt on the carburetor arm and fitting the actuator in the matching radius of the mount bracket.
9. Loosely assemble the mount strap using the two cap screws. Use a small amount of loctite on the threads of cap screws. Do not tighten at this time.

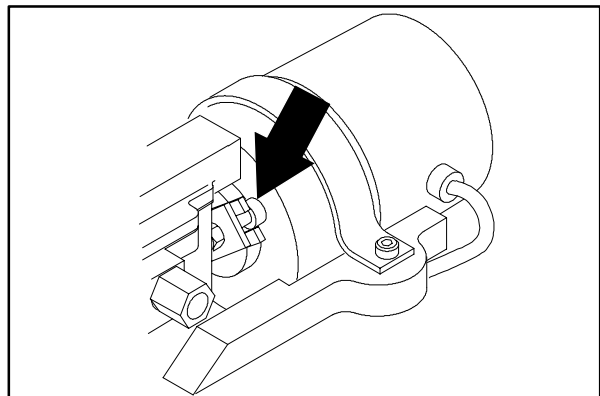
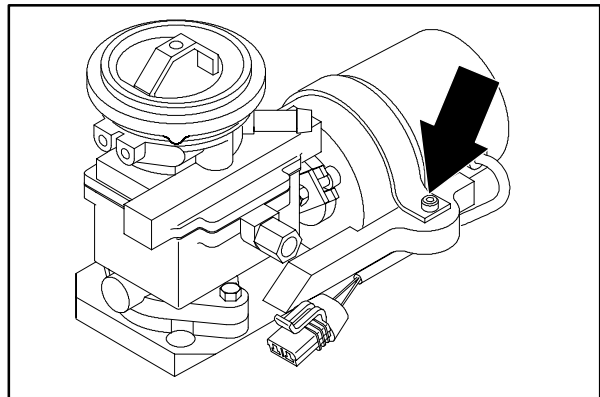

10. Rotate the actuator to just close the carburetor butterfly against the idle stop screw--hold this position.
11. Mark the side (away from the arm) of the actuator at the mount bracket top edge with a pencil. Further rotate the actuator in the direction of closing the butterfly until the pencil mark is above the bracket edge by approximately .20 inches.
12. Visually check that the slotted arm is centered on the length of the shoulder bolt and that there is no interference between the arms or shafts. Tighten the strap cap screws.
13. Check the arm movement--there must be no binding throughout the full stroke and there must be a spring pre-load holding the carburetor in its throttle closed position.
14. Install the wire clamp to the side of the bracket making approximately a 1 inch loop between the actuator and bracket. Tighten the cap screw.
15. Start the machine and check for proper operation.

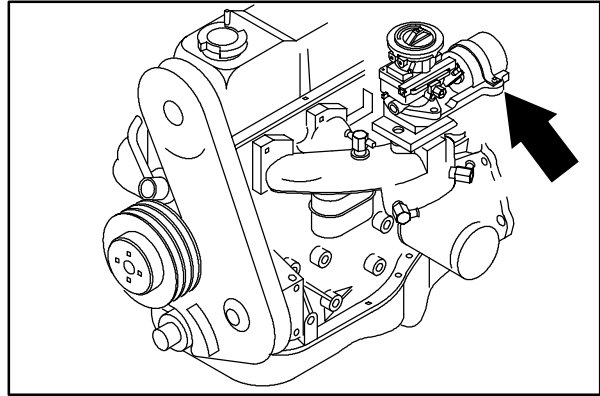

IGNITION SYSTEM

SPARK PLUGS

Clean or replace, and set the gap of the spark plugs every 400 hours of operation. A wire gauge is best for checking the spark plug gap. A flat gauge should not be used unless the electrode surfaces have been dressed with a small file to get parallel surfaces between the center and side electrode. Set the spark plug gap by bending the side electrode. All spark plugs, new or used, should have the gaps checked and reset if necessary.

The proper spark plug gap is 1 mm (0.040 in).

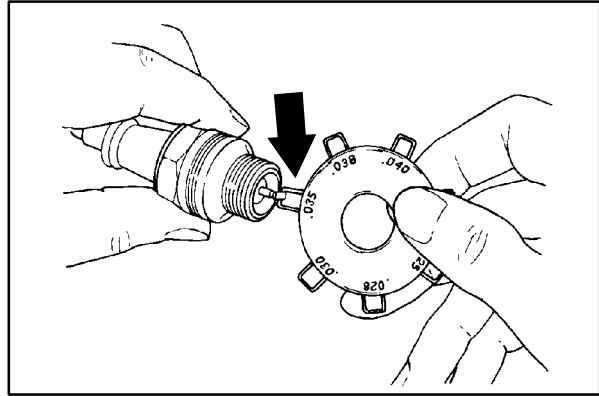

01471

TO REPLACE SPARK PLUGS

FOR SAFETY: Before Leaving Or Servicing Machine; Stop On Level Surface, Set Parking Brake., Turn Off Machine And Remove Key.

1. Clean the spark plug seat in the cylinder head.
2. Use a new seat gasket and screw the plug in by hand.
3. Tighten the spark plugs with a socket wrench of the correct size.

ENGINE IGNITION TIMING

The engine timing should be set at 10° BTDC with the throttle is in the idle position.

CYLINDER HEAD

A three-stage torque procedure should be used when reassembling the cylinder head. Tighten the cylinder head bolts seasonally. See Ford LRG-423, 2.3 Engine Service Manual at the end of this section.

VALVE TAPPET CLEARANCE

The valve tappet clearance must be checked and adjusted if necessary every 400 hours of operation. See Ford LRG-423, 2.3 Engine Service Manual at the end of this section.

Clean the crankcase ventilation hoses, tubes, and fittings and replace the PCV valve every 400 hours of operation.

ENGINE ELECTRICAL SYSTEM

TO REPLACE ENGINE STARTER

FOR SAFETY: Before Leaving Or Servicing Machine; Stop On Level Surface, Set Parking Brake., Turn Off Machine And Remove Key.

1. Open the engine cover and side door.
2. Disconnect battery cables from machine.
3. Remove the air cleaner assembly from the engine.



WARNING: Always disconnect battery cables from machine before working on electrical components.

4. The engine starter can now be accessed from the engine compartment. Reach over the top of the engine and locate the starter.

NOTE: The panel in the operators compartment can be removed for more access.

5. Remove the wires attached to the starter. Label the wires to make sure they are returned to the proper location in the re-assembly procedure.
6. Remove the three M10 hex screws holding the starter to the engine bellhousing. Remove the starter from the machine.
7. Reverse the order of these steps to reinstall a new or rebuilt starter. Tighten the M10 hex screw to 37 - 48 Nm (26-34 ft lb).
8. Reinstall the air cleaner to the engine.
9. Reconnect the battery and start the machine, checking for proper starter operation.

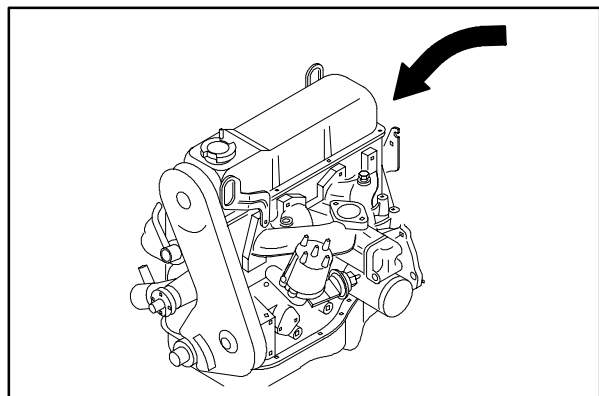
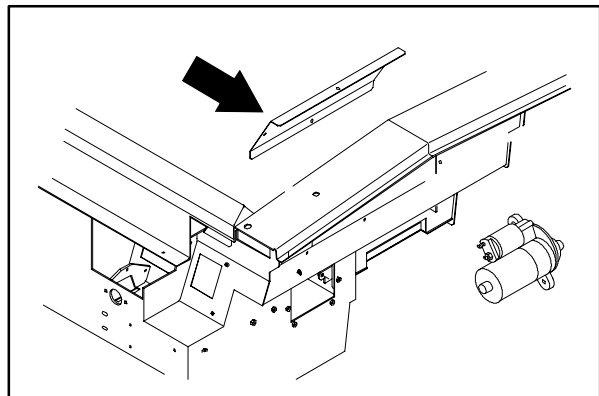
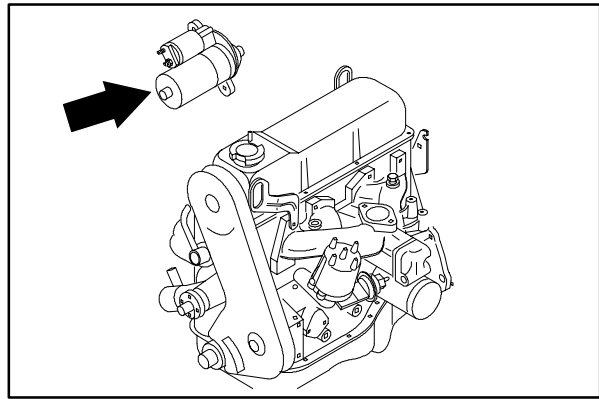

TO REPLACE ENGINE STARTER WITH AIR CONDITIONING

FOR SAFETY: Before Leaving Or Servicing Machine; Stop On Level Surface, Set Parking Brake., Turn Off Machine And Remove Key.

1. Open the engine cover and side door.
2. Disconnect battery cables from machine.

⚠ WARNING: Always disconnect battery cables from machine before working on electrical components.

3. Remove the two nuts holding the air box cover to the air conditioning air box. Remove the air box cover from the machine.

4. Remove the four acorn nuts holding the plastic fan duct assembly to the side panel of the machine. Remove the fan duct from the machine. This fan duct is accessed from the operators compartment.

5. Remove the nuts holding the air conditioning evaporator assembly to the side panel of the machine. This air conditioning condenser assembly is accessed from the operator compartment. Pull the air conditioning condenser assembly as far as possible into the operators compartment.

6. The engine starter can now be accessed from the engine compartment. Reach over the top of the engine and locate the starter.

7. Remove the wires attached to the starter. Label the wires to make sure they are returned to the proper location in the re-assembly procedure.

8. Remove the three M10 hex screws holding the starter to the engine bellhousing. Remove the starter from the machine.

9. Reverse the order of these steps to reinstall a new or rebuilt starter. Tighten the M10 hex screw to 37 - 48 Nm (26-34 ft lb).

10. Reinstall the air conditioning condenser assembly and the plastic fan duct assembly to the machine side panel.

11. Reconnect the battery and start the machine, checking for proper starter operation.

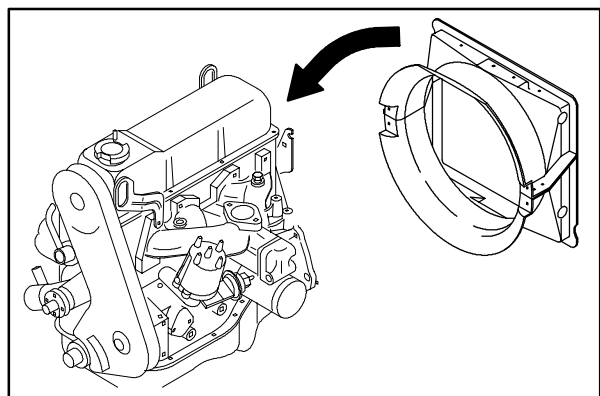
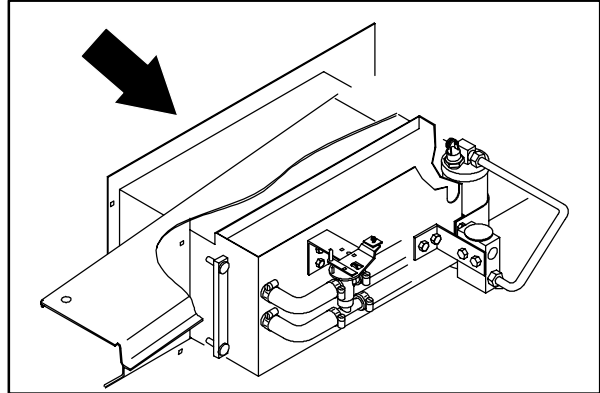
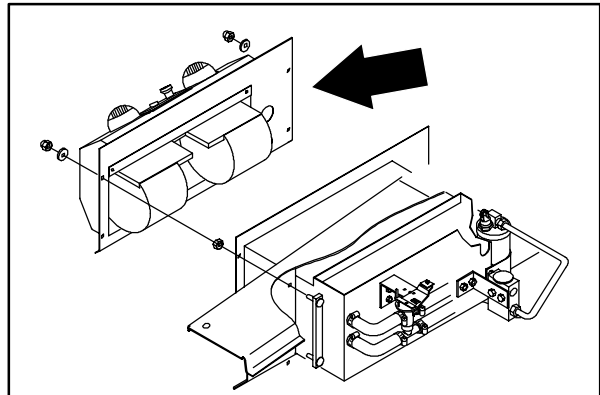
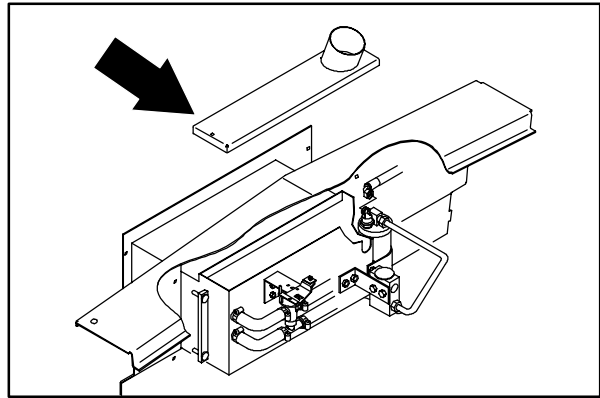

TO REPLACE ENGINE ALTERNATOR

FOR SAFETY: Before Leaving Or Servicing Machine; Stop On Level Surface, Set Parking Brake., Turn Off Machine And Remove Key.

1. Open the engine cover and side door.
2. Disconnect battery cables from machine.



WARNING: Always disconnect battery cables from machine before working on electrical components.

3. The engine alternator can be accessed from the engine compartment. Loosen the M8 hex screw on the top bracket of the alternator.
4. Loosen the M10 hex screw and nyloc nut holding the alternator to the **bottom** mounting bracket. Pivot the alternator in and remove the V-belt.



WARNING: Always disconnect battery cables from machine before working on electrical components.

5. Remove the wires attached to the alternator. Label the wires to make sure they are returned to the proper location in the re-assembly procedure.
6. Remove the M10 hex screw and nyloc nut holding the alternator to the **bottom** mounting bracket. Remove the alternator from the machine.
7. Reverse the order of these steps to reinstall a new or rebuilt alternator. Tighten the M8 hex screw to 18 - 24 Nm (15-20 ft lb). Tighten the M10 hex screw to 37 - 48 Nm (26-34 ft lb).
8. Reconnect the battery and start the machine, checking for proper alternator operation.

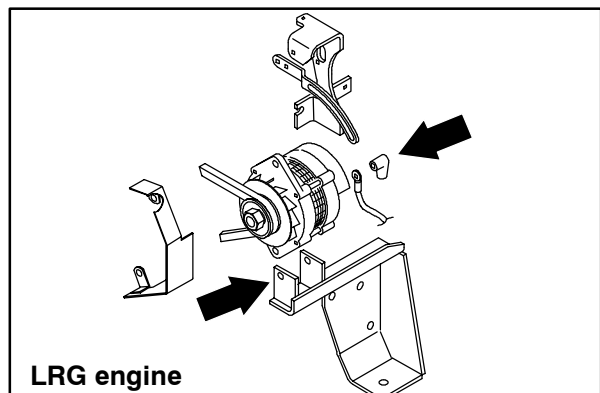
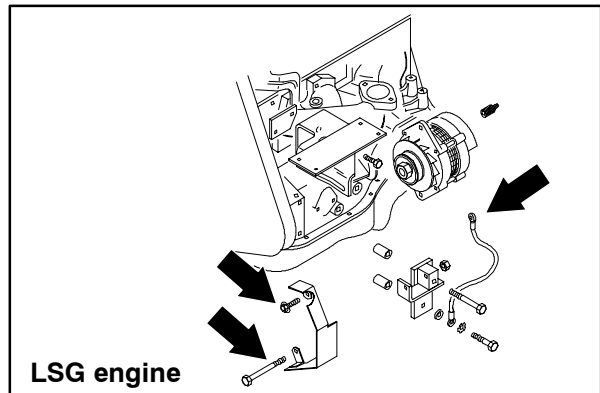
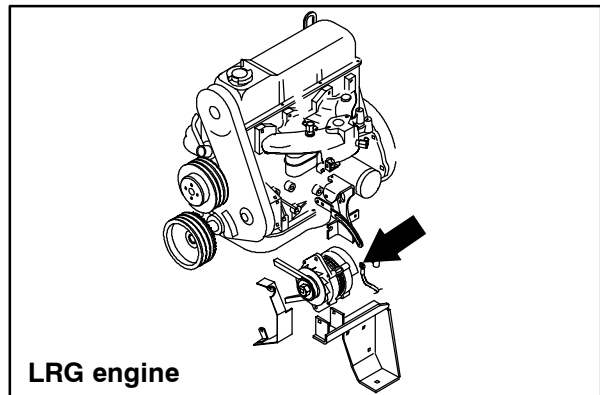
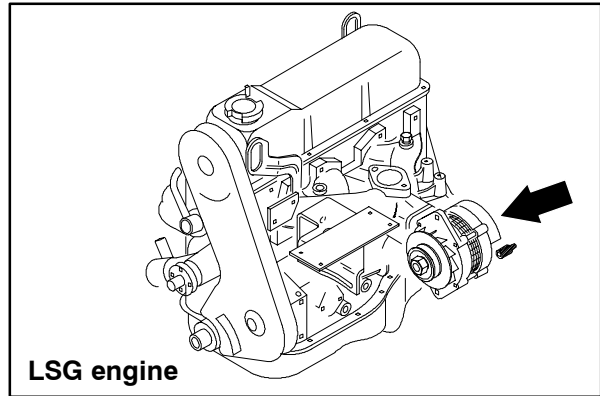

ENGINE-G/LPG

TO REPLACE ENGINE ALTERNATOR WITH AIR CONDITIONING

FOR SAFETY: Before Leaving Or Servicing Machine; Stop On Level Surface, Set Parking Brake., Turn Off Machine And Remove Key.

1. Open the engine cover and side door.
2. Disconnect battery cables from machine.



WARNING: Always disconnect battery cables from machine before working on electrical components.

3. The engine alternator can be accessed from the engine compartment.
4. Loosen the M10 hex screw and nyloc nut holding the alternator to the **bottom** mounting bracket. Pivot the alternator in and remove the V-belt.



WARNING: Always disconnect battery cables from machine before working on electrical components.

5. Remove the wires attached to the alternator. Label the wires to make sure they are returned to the proper location in the re-assembly procedure.
6. Remove the M10 hex screw and nyloc nut holding the alternator to the **bottom** mounting bracket. Remove the alternator from the machine.
7. Reverse the order of these steps to reinstall a new or rebuilt alternator. Tighten the M8 hex screw to 18 - 24 Nm (15-20 ft lb). Tighten the M10 hex screw to 37 - 48 Nm (26-34 ft lb).
8. Reconnect the battery and start the machine, checking for proper alternator operation.

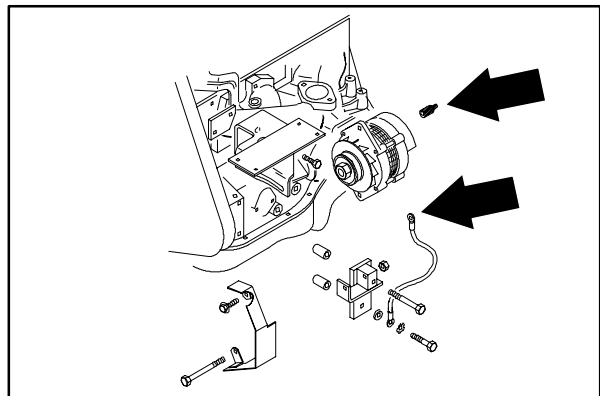
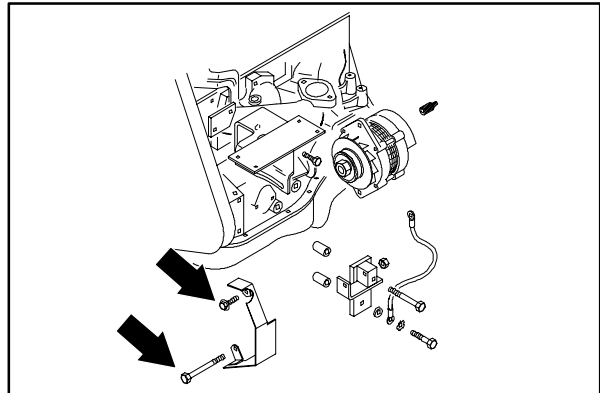
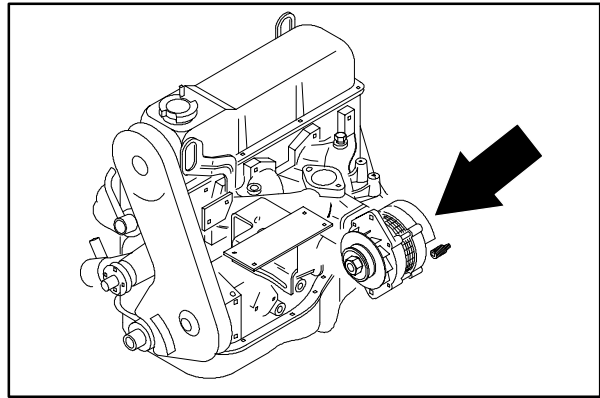

CONTENTS

	Page
PERKINS 200 SERIES ENGINE	7-3
TO REMOVE ENGINE	7-4
TO INSTALL ENGINE	7-5
LUBRICATION	7-7
COOLING SYSTEM	7-7
AIR INTAKE SYSTEM	7-9
AIR FILTER INDICATOR	7-9
AIR FILTER	7-9
TO REPLACE AIR FILTER	
ELEMENT	7-10
FUEL SYSTEM (early machines)	7-11
FUEL FILTER/WATER SEPARATOR	
(early machines)	7-11
TO REPLACE FILTER/WATER	
SEPARATOR CARTRIDGE	
(early machines)	7-11
FUEL LINES (early machines)	7-12
IN-LINE FUEL PUMP	
(early machines)	7-12
FUEL SYSTEM (later machines)	7-13
FUEL FILTER/WATER SEPARATOR	
(later machines)	7-13
TO REPLACE FILTER/WATER	
SEPARATOR CARTRIDGE	
(later machines)	7-13
FUEL LINES (later machines)	7-14
IN-LINE FUEL PUMP	
(later machines)	7-14
ENGINE MOUNTED FUEL FILTER	7-15
TO REPLACE ENGINE MOUNTED	
FUEL FILTER CARTRIDGE	7-15
PRIMING FUEL SYSTEM	7-16
TO PRIME FUEL SYSTEM	
(early machines)	7-16
TO PRIME FUEL SYSTEM	
(later machines)	7-16
ENGINE ELECTRICAL SYSTEM	7-17
TO REPLACE ENGINE STARTER ...	7-17
TO REPLACE ENGINE STARTER	
WITH AIR CONDITIONING	7-18
TO REPLACE ENGINE	
ALTERNATOR	7-19
TO REPLACE ENGINE ALTERNATOR	
WITH AIR CONDITIONING	7-20
ENGINE FAN BELT	7-21

DIESEL ENGINE SERVICE MANUALS

PERKINS 200 Series
TENNANT Part Number 61838

PERKINS 700 Series
TENNANT Part Number 380503

PERKINS 200 SERIES ENGINE

To verify that your machine is equipped with a Perkins 200 Series engine--check the tag on the front right corner of the engine valve cover. The 200 Series engine will have the numbers 204-25.

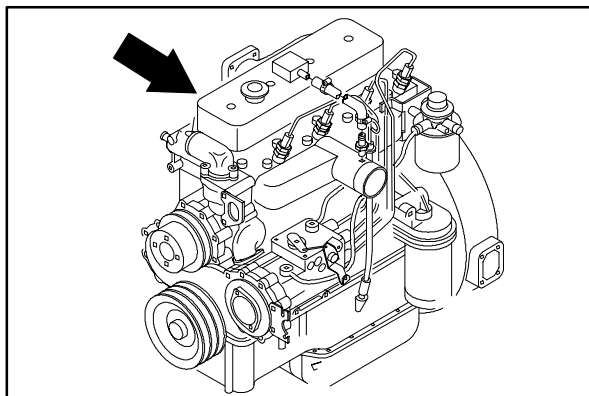

TO REMOVE ENGINE

FOR SAFETY: Before Leaving Or Servicing Machine; Stop On Level Surface, Set Parking Brake., Turn Off Machine And Remove Key.

1. Remove the engine cover and side door.
2. Remove the battery cables from battery.
3. Drain the radiator coolant.
4. Drain the engine oil.
5. Remove the air cleaner assembly.
6. Remove the radiator hoses from the engine.
7. Disconnect the exhaust pipe at the engine manifold.
8. Disconnect the wire harness from all engine components and place it out of the way.
9. Disconnect the engine ground strap from the machine frame.
10. Disconnect both the fuel lines and the return line coming from the fuel tank at the fuel filter.
11. Disconnect the throttle cable from the engine.
12. Remove the two M12 hex screws holding the propel pump to the flywheel housing.
13. Pull the propel pump out of flywheel coupling.
14. Using overhead hoist, hook a chain through the two pick-up points on the engine. Put a slight amount of tension on the chain.
15. Remove the two M12 hex screws from front motor mounts. (these are the vertical ones coming through the rubber isolators.)
16. Remove the two M10 hex screws from rear motor mount. (these are the horizontal ones holding the mount bracket to the bellhousing plate.)
17. The engine can now be carefully lifted out.

NOTE: Be sure to disconnect engine oil drain hose from oil pan before lifting engine completely out of machine.

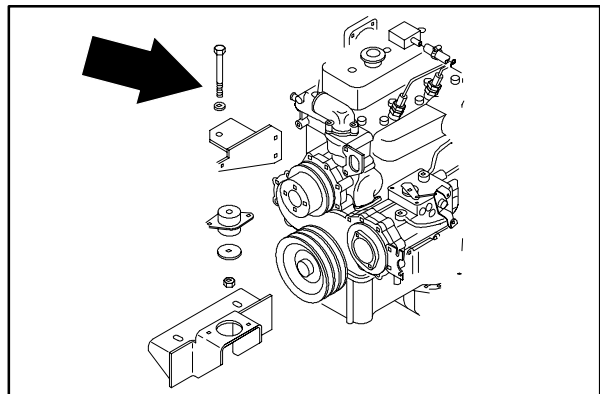
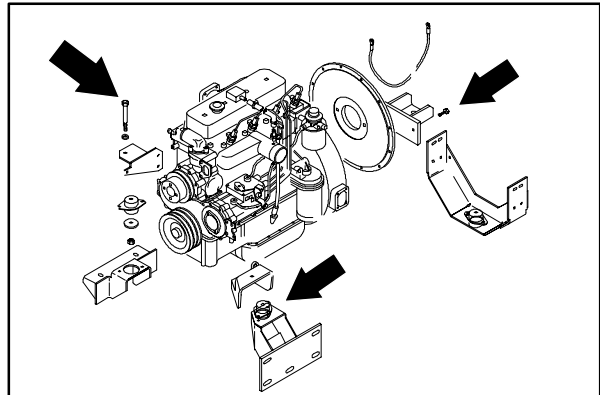
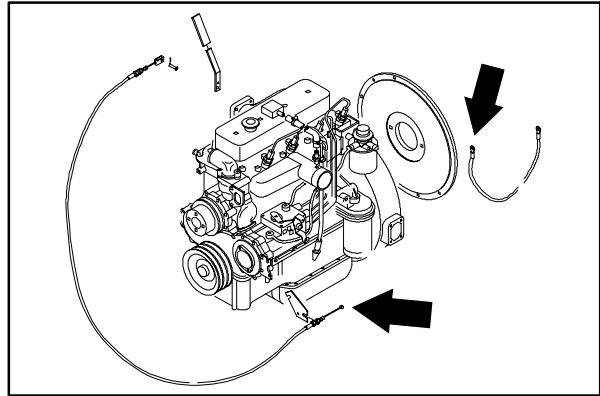
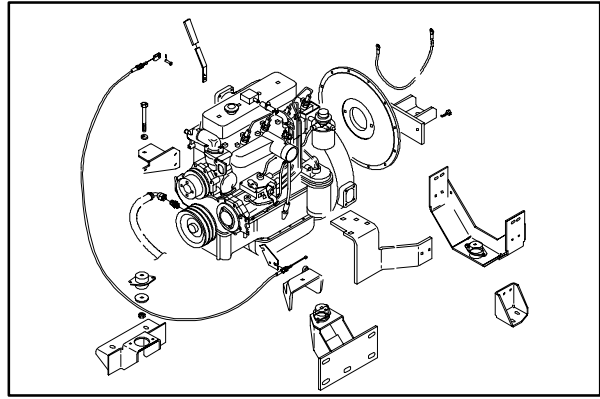

TO INSTALL ENGINE

FOR SAFETY: Before Leaving Or Servicing Machine; Stop On Level Surface, Set Parking Brake., Turn Off Machine And Remove Key.

1. Using an overhead hoist, hook a chain through the two pick-up points on the top of the engine. Position the engine into the engine compartment.
2. Lower the engine assembly carefully down on the motor mounts.

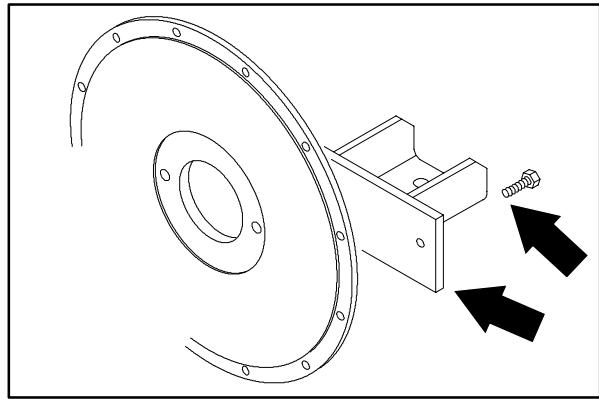

NOTE: Make sure the hoses, wire harness, exhaust pipe and propel pump are pulled back out of the way when lowering engine assembly into place.

3. Reinstall the M12 hex screws into the front motor mounts. Tighten to 64 - 83 Nm (47 - 61 ft lb).
4. Reinstall the rear motor mount on the bellhousing plate using the two M10 hex screws. Tighten to 37 - 48 Nm (26 - 34 ft lb).
5. Reinstall the propel pump back in the bellhousing. Reuse the M12 hex screws. Tighten to 64 - 83 Nm (47 - 61 ft lb).

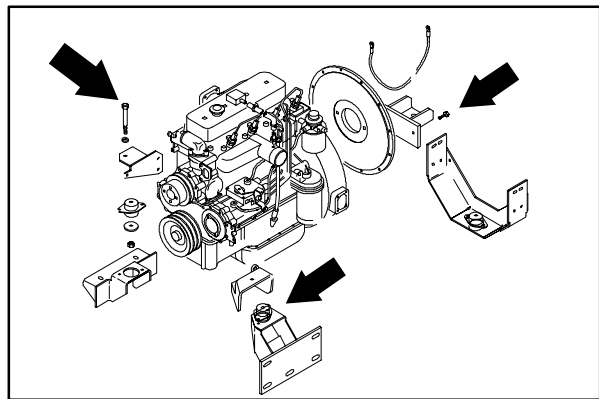

NOTE: Make sure the splines on pump line up with splines in coupler when installing pump.

6. Reinstall the exhaust pipe back on the manifold using four M10 hex screws. Tighten to 52 - 67 Nm (39 - 50 ft lb).

NOTE: Make sure steel gasket is in place when installing exhaust pipe.

7. Reconnect the fuel lines.
8. Reconnect the throttle cable to the engine.
9. Reconnect the ground cable from the bellhousing to the machine frame.

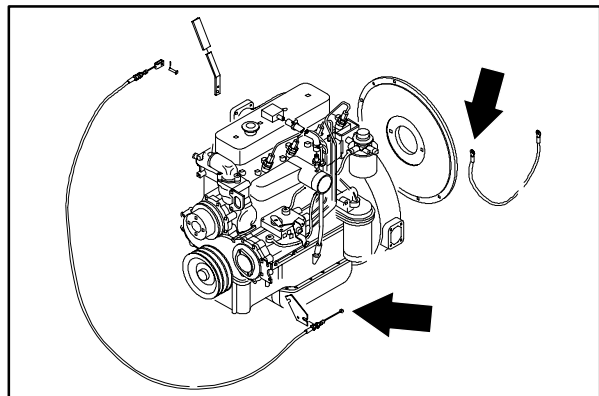

ENGINE-D-PERKINS 200 SERIES

10. Reconnect the oil drain hose to the oil pan and fill the engine with the proper grade of engine oil.
11. Reconnect the main wire harness to the engine components, alternator, starter, oil switch, and the temperature sender.
12. Reinstall the radiator hoses to engine and fill the radiator with antifreeze coolant.
13. Reinstall the air cleaner assembly.
14. Reconnect the battery cables.
15. Jack up the rear of the machine.

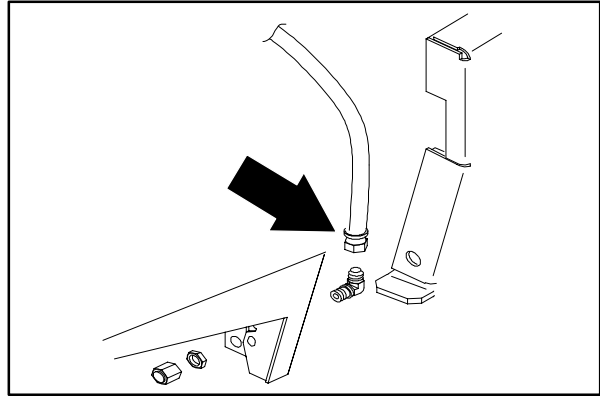

FOR SAFETY: Block machine tires before jacking machine up. Jack machine up at designated locations only. Block machine up with jack stands

16. Start the engine and check for fuel or hydraulic oil leaks.
17. Reinstall the engine cover and side door. Lower the machine and operate, checking for proper operation.

LUBRICATION

Check the engine oil level daily. Change the engine oil and oil filter every 100 hours of machine operation. Use 10W30 SAE-CC/CD rated engine oil.

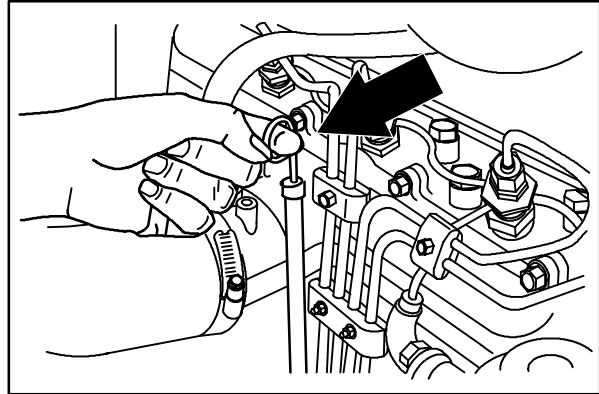

08431

The engine oil drain is located on the left side of the machine inside the main brush compartment.

Fill the engine with oil to the level indicated on the oil dipstick. The engine oil capacity is 6 L (6.3 qt) including the oil filter.

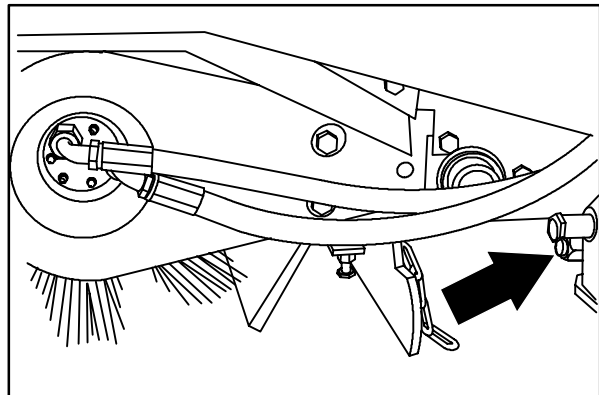

08448

COOLING SYSTEM

Check the radiator coolant level every 100 hours of operation. Use clean water mixed with a permanent-type, ethylene glycol antifreeze to a -34°C (-30°F) rating.

FOR SAFETY: When Servicing Machine, Avoid Contact With Hot Engine Coolant.

ATTENTION! Never pour cold water or cold antifreeze into the radiator of an overheated engine. Allow the engine to cool down to avoid cracking the cylinder head or block. Keep the engine running while adding water.

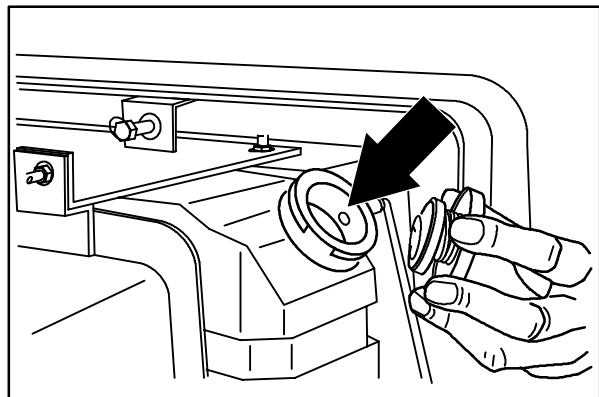

08432

ENGINE-D-PERKINS 200 SERIES

Clean the radiator screen every 100 hours of operation.

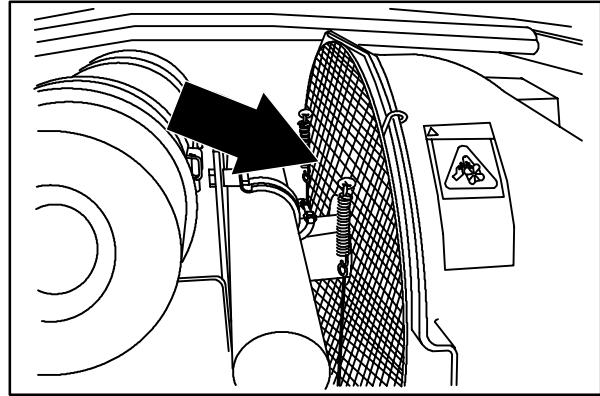

08582

Check the radiator hoses and clamps every 200 hours of operation. Tighten the clamps if they are loose. Replace the hoses and clamps if the hoses are cracked, harden, or swollen.

Check the radiator core exterior and hydraulic cooler fins for debris every 100 hours of operation. Blow or rinse all dust, which may have collected on the radiator, in through the grille and radiator fins, opposite the direction of normal air flow. The grille and hydraulic cooler open for easier cleaning. Be careful not to bend the cooling fins when cleaning. Clean thoroughly to prevent the fins becoming encrusted with dust. Clean the radiator and cooler only after the radiator has cooled to avoid cracking.

FOR SAFETY: When Servicing Machine, Wear Eye And Ear Protection When Using Pressurized Air Or Water.

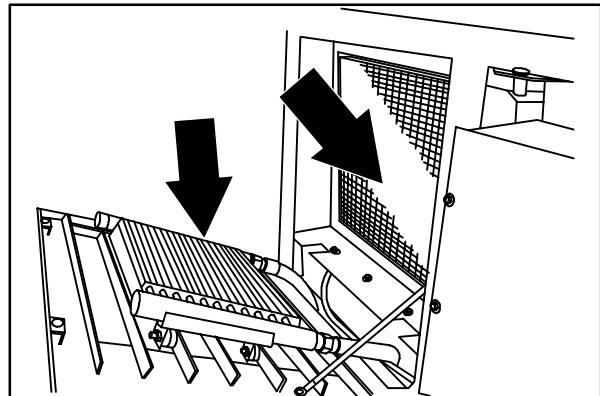

08454

Flush the radiator and the cooling system every 400 hours of operation, using a dependable cleaning compound.

AIR INTAKE SYSTEM

AIR FILTER INDICATOR

The air filter indicator shows when to clean or replace the air filter element. Check the indicator daily. The indicator's red line will move as the air filter element fills with dirt. Do not clean or replace the air filter element until the red line reaches 5 kPa (20 in H₂O) and the "SERVICE WHEN RED" window is filled with red. The indicator's red line may return to a lower reading on the scale when the engine shuts off. The red line will return to a correct reading after the engine runs for a while.

Reset the air filter indicator by pushing the reset button on the end of the indicator after cleaning or replacing the air filter element.

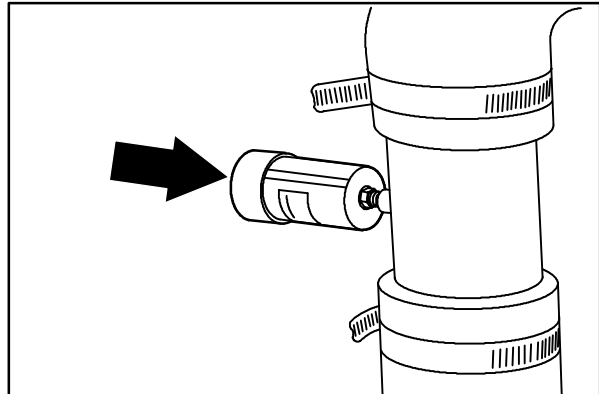

08447

AIR FILTER

The engine air filter housing has a dust cap and a dry cartridge-type air filter element. Empty the dust cap daily. The air filter must be replaced whenever the filter element is damaged or has been cleaned three times.

Machines with the heavy duty air filter option have a safety element. It is inside the standard element. Replace, do not clean this element after the regular element has been damaged or cleaned three times.

Service the air filter element only when the air filter indicator shows restriction in the air intake system. Do not remove the air filter element unless it is restricting air flow.

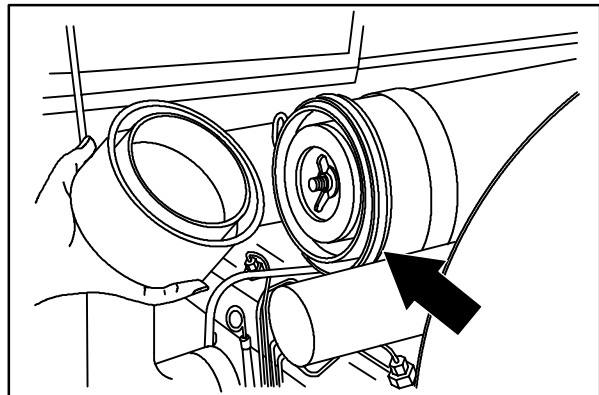

08455

TO REPLACE AIR FILTER ELEMENT

1. Stop the engine and set the machine parking brake.

FOR SAFETY: Before Leaving Or Servicing Machine; Stop On Level Surface, Set Parking Brake, Turn Off Machine And Remove Key.

2. Open the left side and top engine access doors.
3. Unscrew the clamp ring on the filter.
4. Remove the dust cap.
5. Empty the dust cap.
6. Remove the filter wing nut.
7. Gently pull the filter element out of the filter housing.
8. Clean the interior of the air cleaner housing with a damp cloth. Clean the element housing sealing surfaces.
9. Using an air hose, direct dry, clean air maximum 205 kPa (30 psi) up and down pleats on the inside of the filter. Do not rap, tap, or pound dust out of the element.

FOR SAFETY: When Servicing Machine, Wear Eye And Ear Protection When Using Pressurized Air Or Water.

10. After cleaning the air filter element, inspect it for damage by placing a bright light inside. The slightest rupture requires replacement of the filter. Clean and inspect the seals on the ends of the element. They should be unbroken and flexible. Remember to replace the element after cleaning it three times.
11. Install the new or cleaned filter element so the fins on the element are at the intake end of the air cleaner. Be careful not to damage the fins. Make sure the element is seating evenly. Tighten the element wing nut.
12. Install the dust cap with the arrows pointing up. Tighten the clamp ring to hold it in place. Check all intake hose connections for leaks or abrasion.
13. Reset the air filter restriction indicator.
14. Close the access doors.

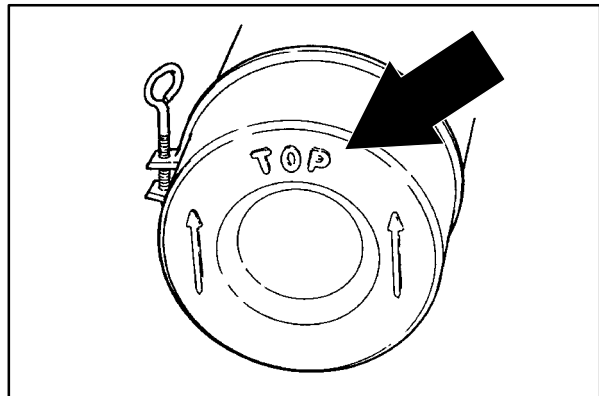
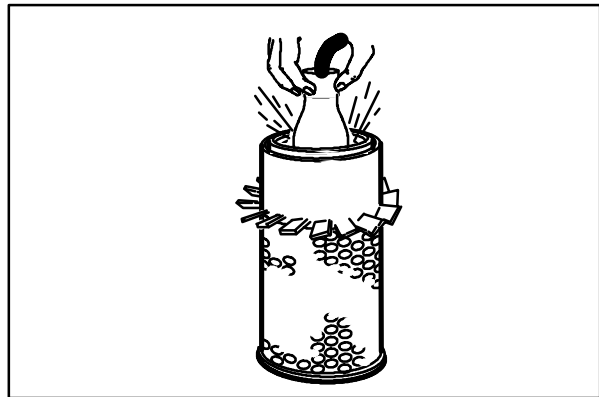
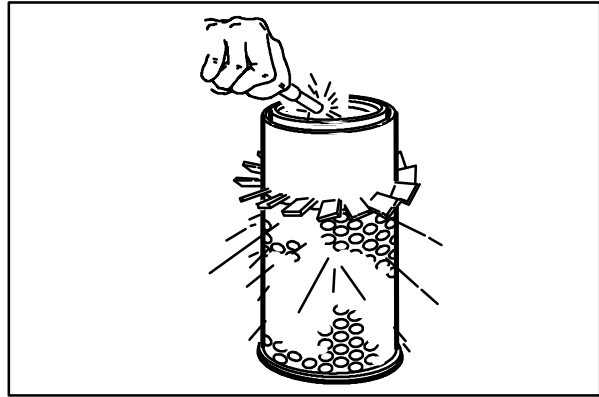

FUEL SYSTEM (early machines)

The diesel fuel system is made up of five basic components which are: fuel tank, fuel filter, fuel water trap filter, fuel pump, injection pump, and injectors.

Fuel flows from the fuel tank through the fuel water trap-filter. The water trap-filter separates water and impurities from the fuel. From the fuel water trap-filter, fuel is drawn through the electric fuel pump and pumped to the engine mounted fuel filter and then to the injection pump. The injection pump pressurizes and sends fuel to the injectors. The injectors atomize and inject proper amounts of fuel into the combustion chamber at the proper times. Excess fuel is returned to the fuel tank through an overflow pipe.

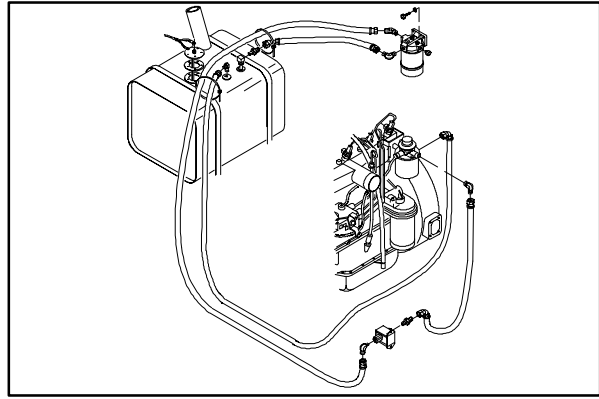

FUEL FILTER/WATER SEPARATOR (early machines)

The fuel filter/water separator separates water and impurities from the fuel. It is located at the back of the machine underneath and behind the bumper. The bottom portion of the unit is the water trap. The middle portion is the filter element.

Drain the water trap of water daily. To drain the water trap, loosen the drain knob on the bottom of the unit. First water, then diesel fuel will drain. Tighten the drain knob when diesel fuel appears.

Replace the fuel filter element and clean the water trap every 400 hours of operation.

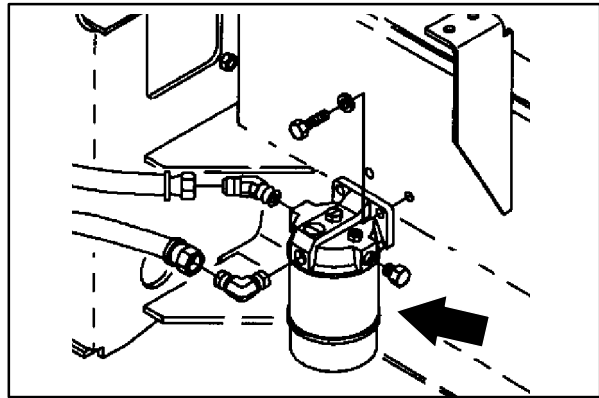

TO REPLACE FILTER/WATER SEPARATOR CARTRIDGE (early machines)

1. Stop the engine and set the machine parking brake.

FOR SAFETY: Before Leaving Or Servicing Machine; Stop On Level Surface, Set Parking Brake, And Turn Off Machine.

2. Loosen the unit vent plug and open the water trap drain to drain diesel fuel.
3. Remove the filter cartridge from the filter head.
4. Lubricate the o-ring of the new filter cartridge and spin it onto the filter head.
5. Bleed the fuel lines of air as described in TO PRIME FUEL SYSTEM.

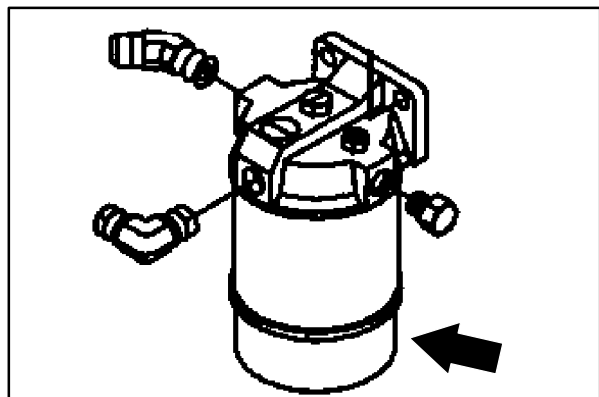

ENGINE-D-PERKINS 200 SERIES

FUEL LINES (early machines)

Check the fuel lines every 50 hours of operation. If the clamp band is loose, apply oil to the screw of the band, and securely tighten the band.

Made of rubber, the fuel lines become worn out whether the engine has been used much or not. Replace the fuel lines and clamp bands every two years.

If the fuel lines and clamp bands are found worn or damaged before two years' time, replace or repair them at once. Bleed the fuel system after replacement of any of the fuel lines, see TO PRIME THE FUEL SYSTEM. When the fuel lines are not installed, plug both ends with clean cloth or paper to prevent dirt from entering the lines. Dirt in the lines can cause fuel injection pump malfunction.

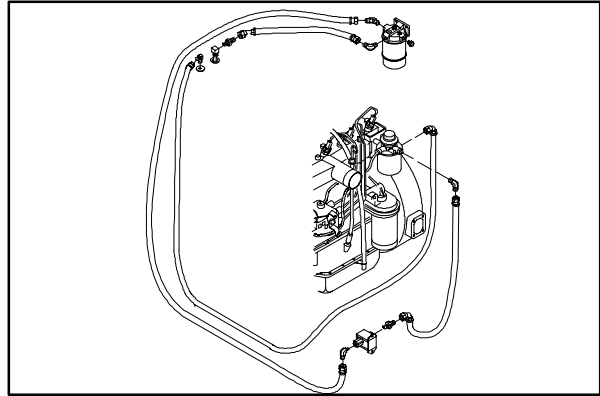

IN-LINE FUEL PUMP (early machines)

The in-line fuel pump is used to pull fuel from the tank, through the fuel/water separator and into the engine mounted fuel filter. The in-line fuel pump is electric and runs off the 12VDC battery of the machine.

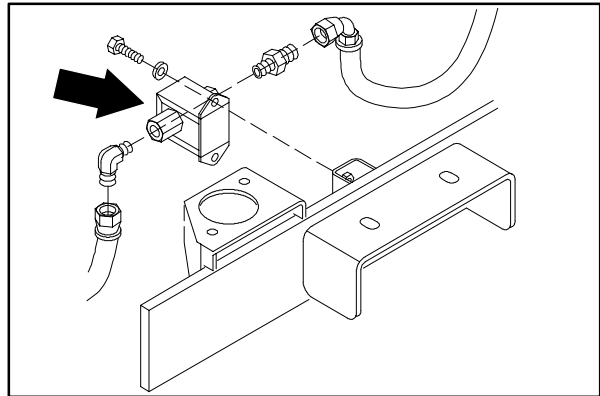

FUEL SYSTEM (later machines)

The diesel fuel system is made up of five basic components which are: fuel tank, fuel filter, fuel water trap filter, fuel pump, injection pump, and injectors.

Fuel flows from the fuel tank through the in-line fuel pump, into the fuel water trap-filter, and then to the engine mounted fuel filter. The water trap-filter separates water and impurities from the fuel. From the fuel water trap-filter, fuel is drawn through the electric fuel pump and pumped to the injection pump. The injection pump pressurizes and sends fuel to the injectors. The injectors atomize and inject proper amounts of fuel into the combustion chamber at the proper times. Excess fuel is returned to the fuel tank through an overflow pipe.

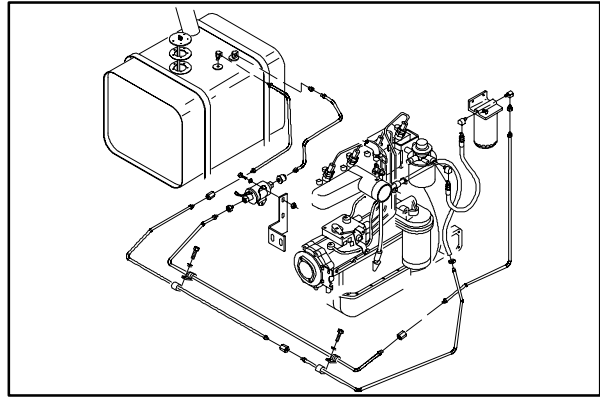

FUEL FILTER/WATER SEPARATOR (later machines)

The fuel filter/water separator separates water and impurities from the fuel. It is located at the back of the machine underneath and behind the bumper. The bottom portion of the unit is the water trap. The middle portion is the filter element.

Drain the water trap of water daily. To drain the water trap, loosen the drain knob on the bottom of the unit. First water, then diesel fuel will drain. Tighten the drain knob when diesel fuel appears.

Replace the fuel filter element and clean the water trap every 400 hours of operation.

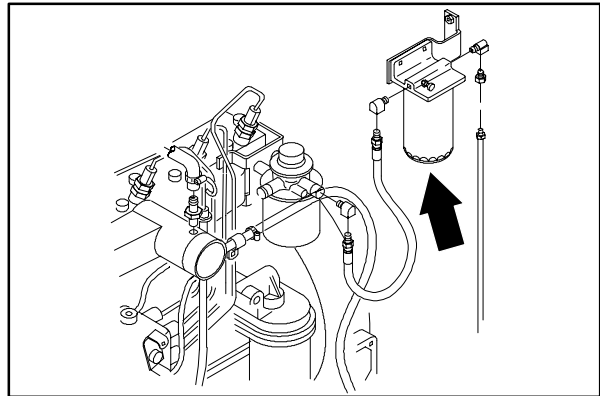

TO REPLACE FILTER/WATER SEPARATOR CARTRIDGE (later machines)

1. Stop the engine and set the machine parking brake.

FOR SAFETY: Before Leaving Or Servicing Machine; Stop On Level Surface, Set Parking Brake, And Turn Off Machine.

2. Loosen the unit vent plug and open the water trap drain to drain diesel fuel.
3. Remove the filter cartridge from the filter head.
4. Lubricate the o-ring of the new filter cartridge and spin it onto the filter head.
5. Bleed the fuel lines of air as described in TO PRIME FUEL SYSTEM.

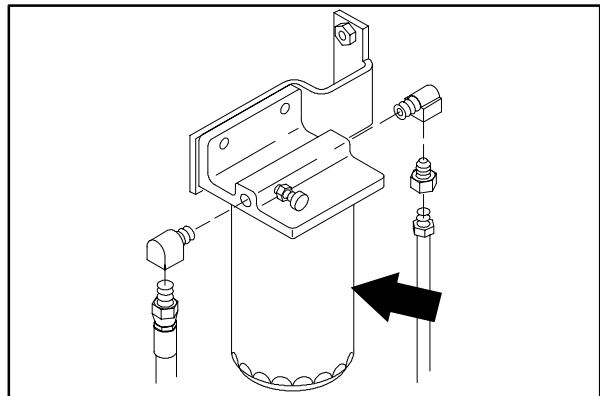

ENGINE-D-PERKINS 200 SERIES

FUEL LINES (later machines)

Check the fuel lines every 50 hours of operation. If the clamp band is loose, apply oil to the screw of the band, and securely tighten the band.

Portions of the fuel line system are made of rubber. The fuel lines may become worn out whether the engine has been used much or not. Replace the fuel lines and clamp bands every two years.

If the fuel lines and clamp bands are found worn or damaged before two years' time, replace or repair them at once. Bleed the fuel system after replacement of any of the fuel lines, see TO PRIME THE FUEL SYSTEM. When the fuel lines are not installed, plug both ends with clean cloth or paper to prevent dirt from entering the lines. Dirt in the lines can cause fuel injection pump malfunction.

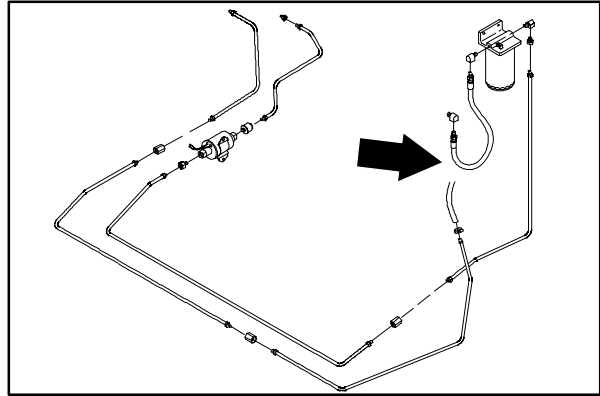

IN-LINE FUEL PUMP (later machines)

The in-line fuel pump is used to pull fuel from the tank, through the in-line filter, and into the fuel/water separator. The in-line fuel pump is electric and runs off the 12VDC battery of the machine.

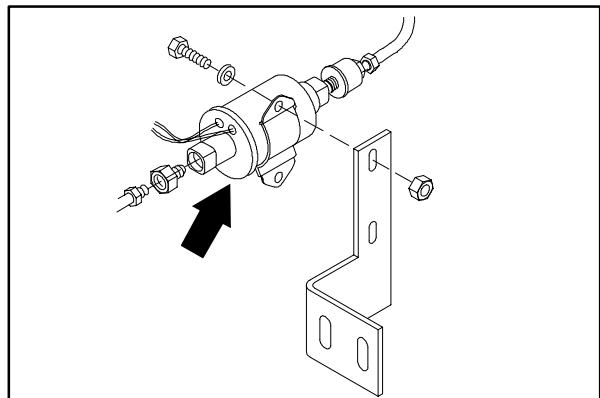

ENGINE MOUNTED FUEL FILTER

The Perkins 200 Series engine comes equipped with a factory installed fuel filter. The engine mounted filter has a replaceable cartridge.

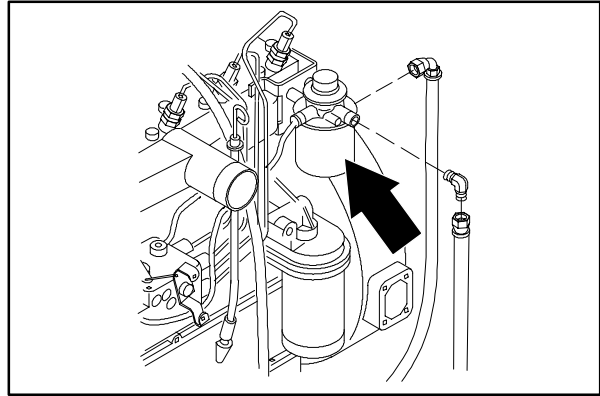
**TO REPLACE ENGINE MOUNTED FUEL FILTER CARTRIDGE**

1. Stop the engine and set the machine parking brake.

FOR SAFETY: Before Leaving Or Servicing Machine; Stop On Level Surface, Set Parking Brake, And Turn Off Machine.

2. Loosen the unit vent plug and open the water trap drain to drain diesel fuel.
3. Remove the filter cartridge from the filter head.
4. Remove the water trap bowl from the filter element.
5. Discard the old filter cartridge.
6. Lubricate the o-ring and spin the new filter cartridge onto the filter base.
7. Bleed the fuel lines of air as described in TO PRIME FUEL SYSTEM.

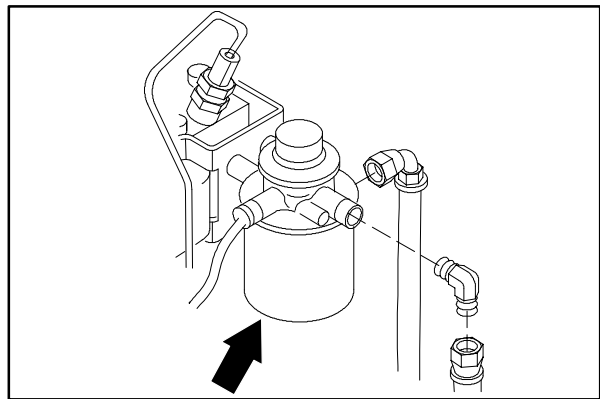

PRIMING FUEL SYSTEM

Priming the fuel system removes pockets of air in the fuel lines and fuel components. Air in the fuel system will prevent smooth engine operation.

Prime the fuel system after running out of fuel, changing fuel filter elements or repairing a fuel system component.

TO PRIME FUEL SYSTEM (early machines)

FOR SAFETY: Before Leaving Or Servicing Machine; Stop On Level Surface, Set Parking Brake, And Turn Off Machine.

1. Stop the engine and set the machine parking brake.
2. Fill the fuel tank.
3. Open the side and top engine access doors.
4. Open the air vent on top of the fuel filter mounted on engine.
5. Start the engine, operate it for one minute, then stop it; or operate the starter motor in ten-second intervals until a steady stream of fuel flows from the vent.
6. Close the air vent.
7. Close the access doors.

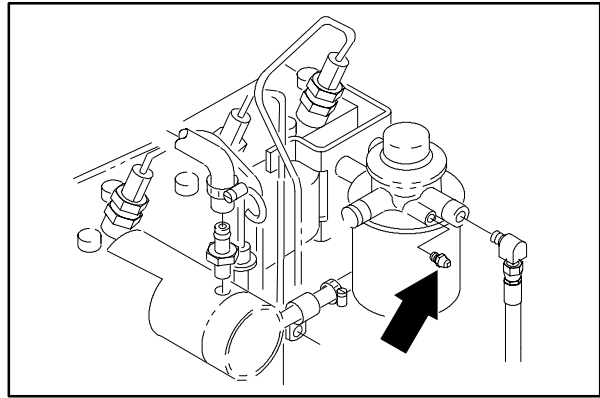

TO PRIME FUEL SYSTEM (later machines)

FOR SAFETY: Before Leaving Or Servicing Machine; Stop On Level Surface, Set Parking Brake, And Turn Off Machine.

1. Stop the engine and set the machine parking brake.
2. Fill the fuel tank.
3. Open the side and top engine access doors.
4. Open the air vent on top of the fuel filter mounted on engine fan shroud.
5. Start the engine, operate it for one minute, then stop it; or operate the starter motor in ten-second intervals until a steady stream of fuel flows from the vent.
6. Close the air vent.
7. Close the access doors.

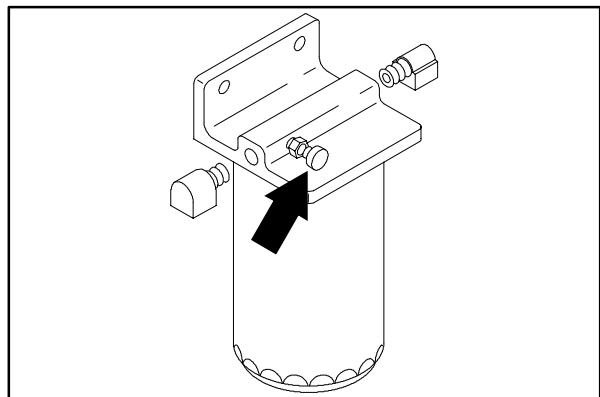

ENGINE ELECTRICAL SYSTEM

TO REPLACE ENGINE STARTER

FOR SAFETY: Before Leaving Or Servicing Machine; Stop On Level Surface, Set Parking Brake, And Turn Off Machine.

1. Open the engine cover and side door.
2. Disconnect battery cables from machine.



WARNING: Always disconnect battery cables from machine before working on electrical components.

3. Remove the air cleaner assembly from the engine.
4. The engine starter can now be accessed from the engine compartment. Reach over the top of the engine and locate the starter.

NOTE: The panel in the operators compartment can be removed for more access.

5. Remove the wires attached to the starter. Label the wires to make sure they are returned to the proper location in the re-assembly procedure.
6. Remove the three M10 hex screws holding the starter to the engine bellhousing. Remove the starter from the machine.
7. Reverse the order of these steps to reinstall a new or rebuilt starter. Tighten the M10 hex screw to 37 - 48 Nm (26-34 ft lb).
8. Reconnect the battery and start the machine, checking for proper starter operation.

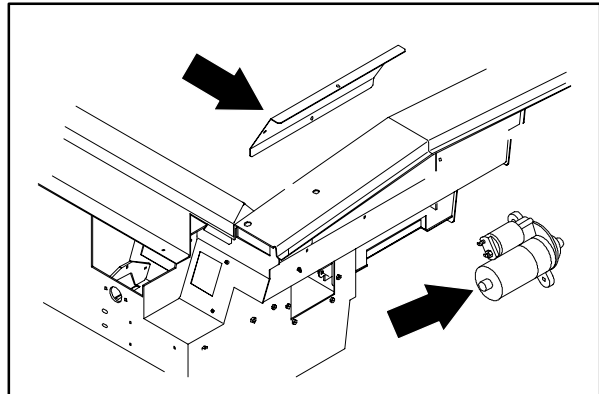
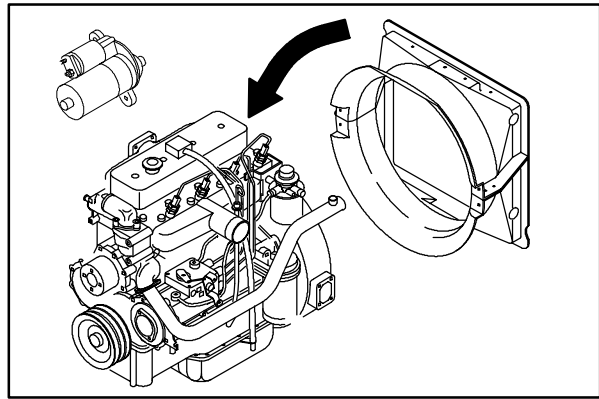

ENGINE-D-PERKINS 200 SERIES

TO REPLACE ENGINE STARTER WITH AIR CONDITIONING

FOR SAFETY: Before Leaving Or Servicing Machine; Stop On Level Surface, Set Parking Brake, And Turn Off Machine.

1. Open the engine cover and side door.
2. Disconnect battery cables from machine.

! WARNING: Always disconnect battery cables from machine before working on electrical components.

3. Remove the two nuts holding the air box cover to the air conditioning air box. Remove the air box cover from the machine.
4. Remove the four acorn nuts holding the plastic fan duct assembly to the side panel of the machine. Remove the fan duct from the machine. This fan duct is accessed from the operators compartment.
5. Remove the nuts holding the air conditioning evaporator assembly to the side panel of the machine. This air conditioning condenser assembly is accessed from the operator compartment. Pull the air conditioning condenser assembly as far as possible into the operators compartment.
6. Remove the wires attached to the starter. Label the wires to make sure they are returned to the proper location in the re-assembly procedure.
7. Remove the three M10 hex screws holding the starter to the engine bellhousing. Remove the starter from the machine.
8. Reverse the order of these steps to reinstall a new or rebuilt starter. Tighten the M10 hex screw to 37 - 48 Nm (26-34 ft lb).
9. Reinstall the air conditioning condenser assembly and the plastic fan duct assembly to the machine side panel.
10. Reconnect the battery and start the machine, checking for proper starter operation.

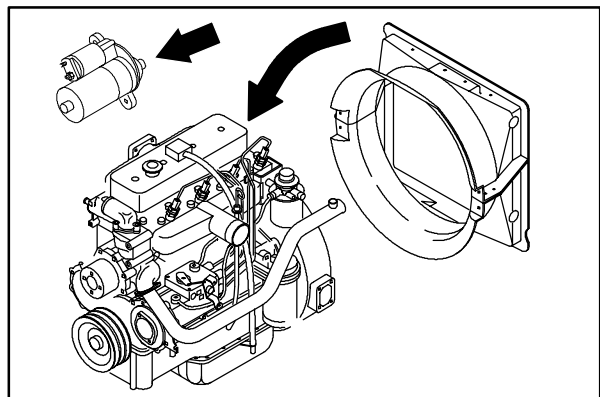
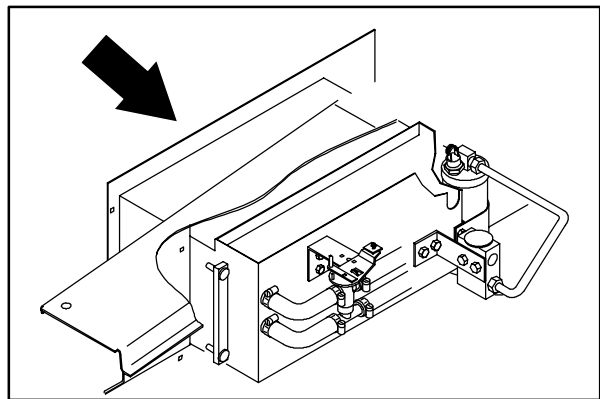
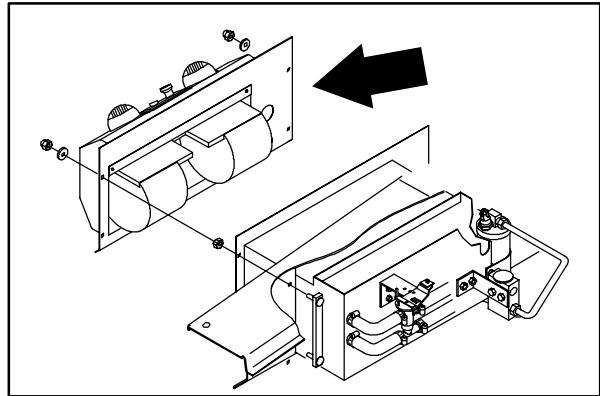
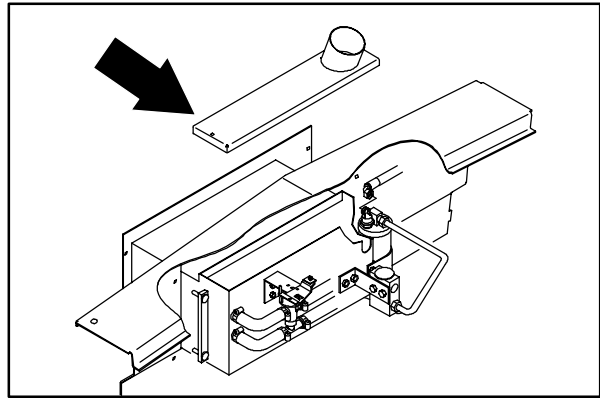

TO REPLACE ENGINE ALTERNATOR

FOR SAFETY: Before Leaving Or Servicing Machine; Stop On Level Surface, Set Parking Brake., Turn Off Machine And Remove Key.

1. Open the engine cover and side door.
2. Disconnect battery cables from machine.

! WARNING: Always disconnect battery cables from machine before working on electrical components.

3. The engine alternator can be accessed from the engine compartment. Reach over the top of the engine and remove the M8 hex screw holding the alternator to the **top** mounting bracket.

NOTE: The panel in the operators compartment can be removed for more access.

4. Loosen the M10 hex screw and nyloc nut holding the alternator to the **bottom** mounting bracket. Pivot the alternator in and remove the V-belt.

! WARNING: Always disconnect battery cables from machine before working on electrical components.

5. Remove the wires attached to the alternator. Label the wires to make sure they are returned to the proper location in the re-assembly procedure.
6. Remove the M10 hex screw and nyloc nut holding the alternator to the **bottom** mounting bracket. Remove the alternator from the machine.
7. Reverse the order of these steps to reinstall a new or rebuilt alternator. Tighten the M8 hex screw to 18 - 24 Nm (15-20 ft lb). Tighten the M10 hex screw to 37 - 48 Nm (26-34 ft lb).

8. Reconnect the battery and start the machine, checking for proper alternator operation.

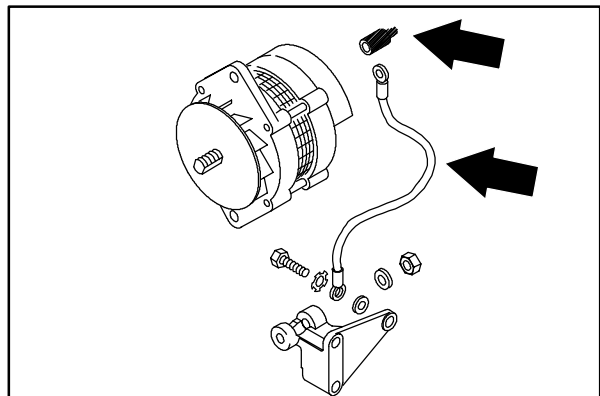
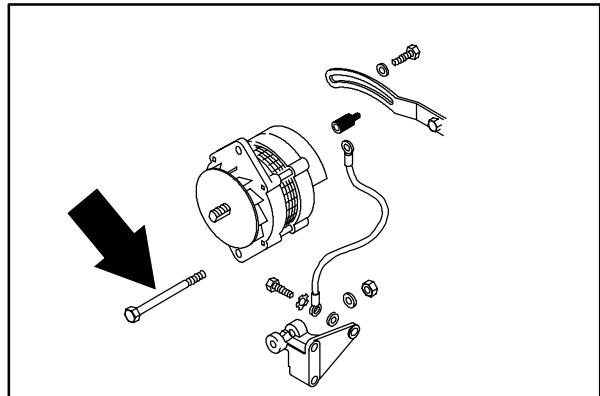
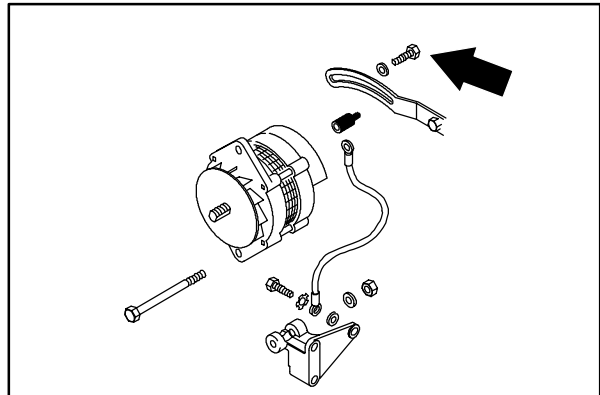
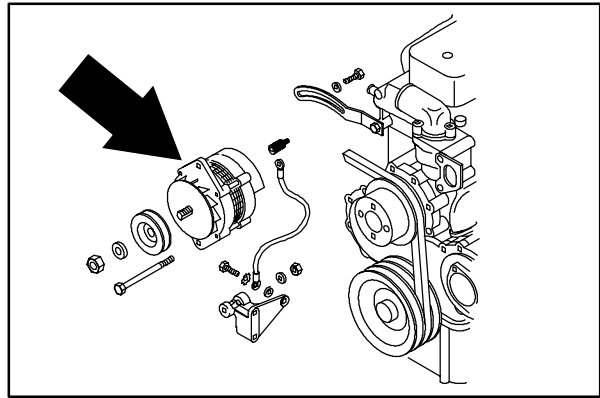

ENGINE-D-PERKINS 200 SERIES

TO REPLACE ENGINE ALTERNATOR WITH AIR CONDITIONING

FOR SAFETY: Before Leaving Or Servicing Machine; Stop On Level Surface, Set Parking Brake., Turn Off Machine And Remove Key.

1. Open the engine cover and side door.
2. Disconnect battery cables from machine.

! WARNING: Always disconnect battery cables from machine before working on electrical components.

3. Remove the two nuts holding the air box cover to the air conditioning air box. Remove the air box cover from the machine.
4. Remove the four acorn nuts holding the plastic fan duct assembly to the side panel of the machine. Remove the fan duct from the machine. This fan duct is accessed from the operators compartment.
5. Remove the nuts holding the air conditioning evaporator assembly to the side panel of the machine. This air conditioning condenser assembly is accessed from the operator compartment. Pull the air conditioning condenser assembly as far as possible into the operators compartment.
6. The engine alternator can now be accessed from the engine compartment. Reach over the top of the engine and remove the M8 hex screw holding the alternator to the **top** mounting bracket.
7. Loosen the M10 hex screw and nyloc nut holding the alternator to the **bottom** mounting bracket. Pivot the alternator in and remove the V-belt.

! WARNING: Always disconnect battery cables from machine before working on electrical components.

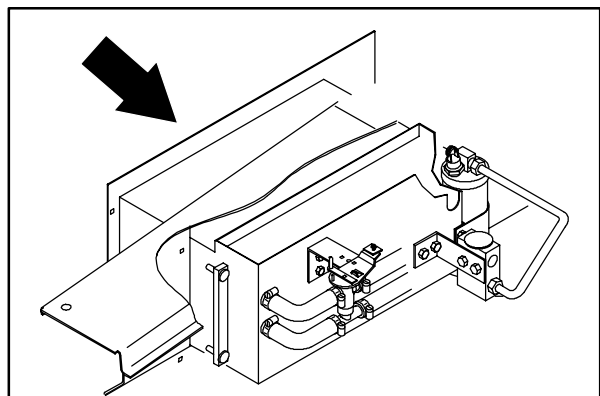
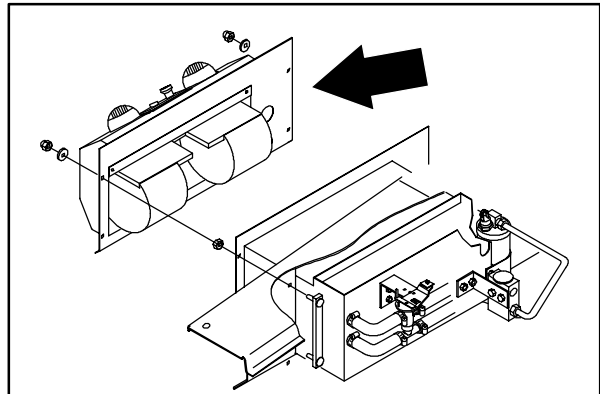
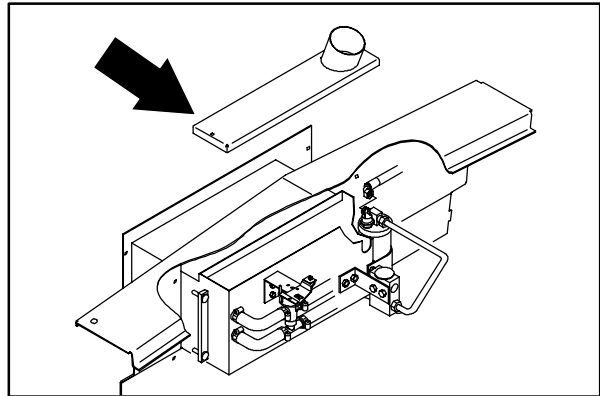
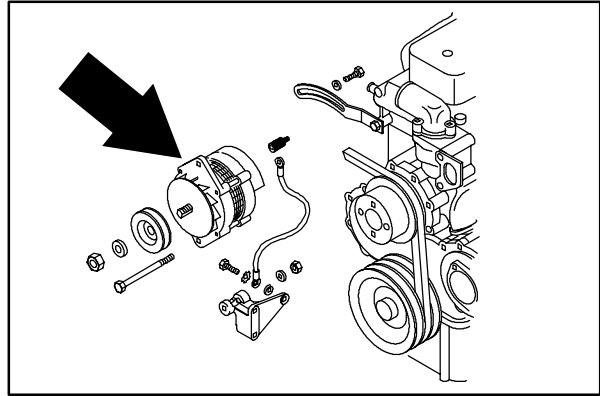

8. Remove the wires attached to the alternator.
9. Remove the M10 hex screw and nyloc nut holding the alternator to the **bottom** mounting bracket. Remove the alternator from the machine.
10. Install the new alternator in the machine. Reinstall the M10 screw in the lower mount hole and the M8 in the upper mount hole.
11. Position the V-belt over the alternator pulley. Pull the alternator tight and tighten the hardware. Tighten the M8 hex screw to 18 - 24 Nm (15-20 ft lb). Tighten the M10 hex screw to 37 - 48 Nm (26-34 ft lb).
12. Check the V-belt for proper tension. See ENGINE ALTERNATOR BELT instructions.
13. Reconnect the wires to the new alternator. See schematic in the ELECTRICAL section.
14. Reconnect the battery and start the machine. Check for proper alternator operation.

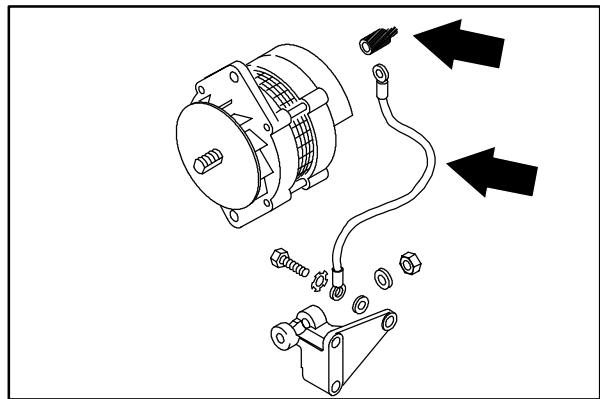
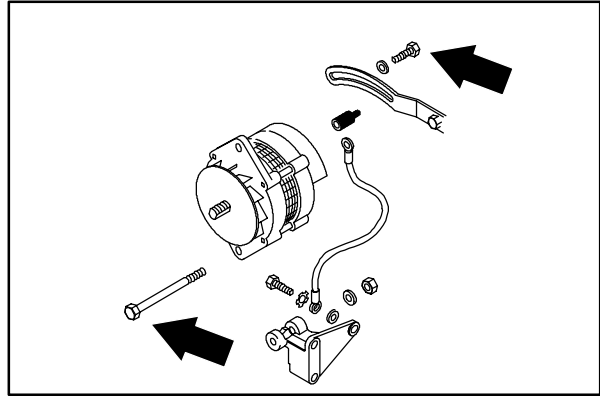

ENGINE FAN BELT

The engine fan belt is driven by the engine crankshaft pulley and drives the alternator pulley. Proper belt tension is 13 mm (0.50 in) from a force of 4 to 5 kg (8 to 10 lb) applied at the mid-point of the longest span.

Check and adjust the belt tension every 100 hours of operation.

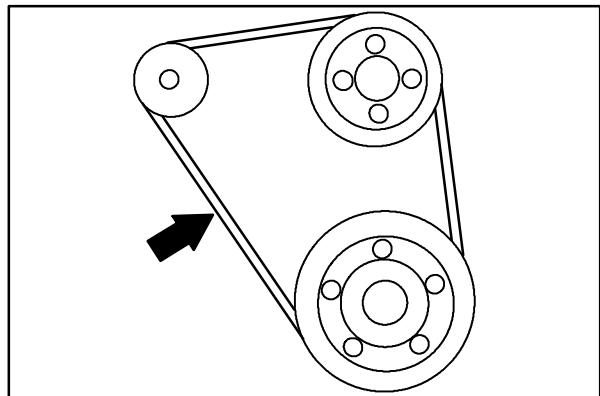

08935

CONTENTS

	Page
PERKINS 700 SERIES ENGINE	8-3
TO REMOVE ENGINE	8-4
TO INSTALL ENGINE	8-5
LUBRICATION	8-7
COOLING SYSTEM	8-7
AIR INTAKE SYSTEM	8-9
AIR FILTER INDICATOR	8-9
AIR FILTER	8-9
TO REPLACE AIR FILTER ELEMENT	8-10
FUEL SYSTEM - DIESEL	8-11
DIESEL FUEL SYSTEM	8-11
FUEL FILTER/WATER SEPARATOR .	8-11
TO REPLACE THE FUEL FILTER CARTRIDGE	8-11
IN-LINE FILTER	8-12
IN-LINE FUEL PUMP	8-12
FUEL LINES	8-12
PRIMING FUEL SYSTEM	8-13
TO PRIME FUEL SYSTEM	8-13
ENGINE ELECTRICAL SYSTEM	8-14
TO REPLACE ENGINE STARTER ...	8-14
TO REPLACE ENGINE ALTERNATOR	8-15
ENGINE ALTERNATOR BELT	8-16

DIESEL ENGINE SERVICE MANUALS

PERKINS 200 Series
TENNANT Part Number 61838

PERKINS 700 Series
TENNANT Part Number 380503

PERKINS 700 SERIES ENGINE

To verify that your machine is equipped with a Perkins 700 Series engine--check the tag on the top of the engine valve cover.

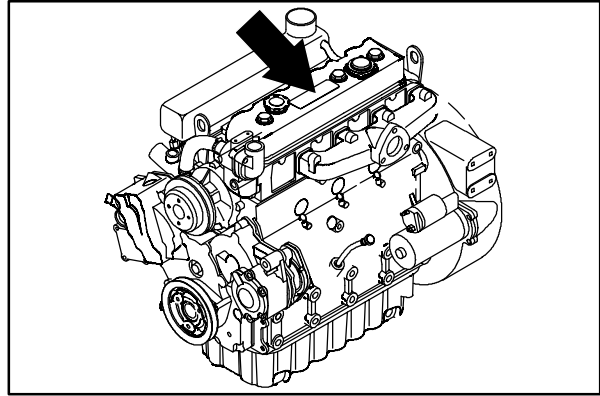

TO REMOVE ENGINE

FOR SAFETY: Before Leaving Or Servicing Machine; Stop On Level Surface, Set Parking Brake., Turn Off Machine And Remove Key.

1. Remove the air cleaner assembly.
2. Remove the engine covers and side door.
3. Remove the battery cables from battery.
4. Drain the radiator coolant.
5. Drain the engine oil.
6. Remove the radiator hoses from the engine.
7. Disconnect the exhaust pipe at the engine manifold.
8. Disconnect the wire harness from all engine components and place it out of the way.
9. Disconnect the engine ground strap from the machine frame.
10. Disconnect both the fuel lines at the fuel filter.
11. Remove the two M12 hex screws holding the propel pump to the flywheel housing.
12. Pull the propel pump out of flywheel coupling.
13. Using overhead hoist, hook a chain through the two pick-up points on the engine. Put a slight amount of tension on the chain.
14. Remove the two M12 hex screws from front motor mounts. (these are the vertical ones coming through the rubber isolators.)
15. Remove the two M10 hex screws from rear motor mount. (these are the horizontal ones holding the mount bracket to the bellhousing plate.)
16. The engine can now be carefully lifted out.

NOTE: Be sure to disconnect engine oil drain hose from oil pan before lifting engine completely out of machine.

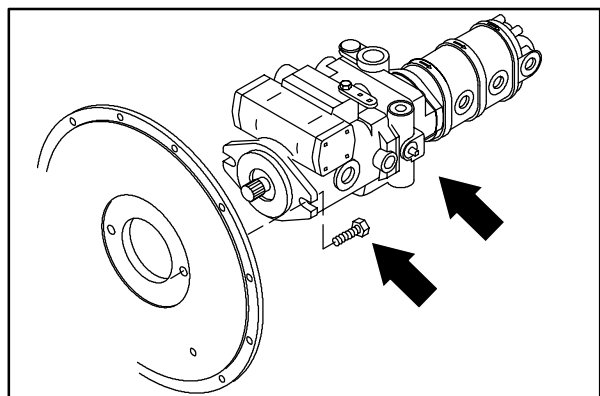
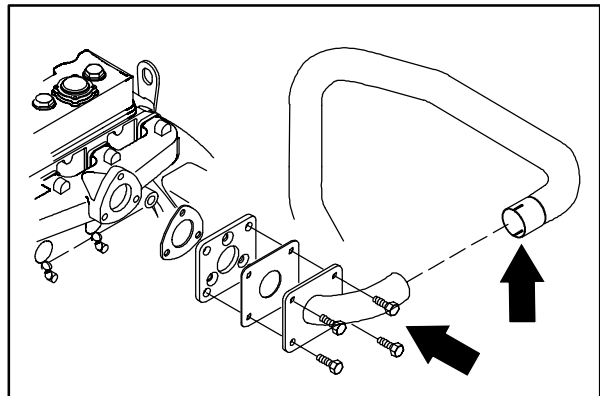
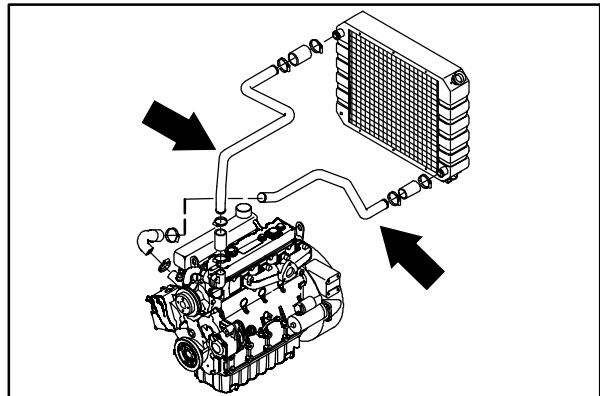
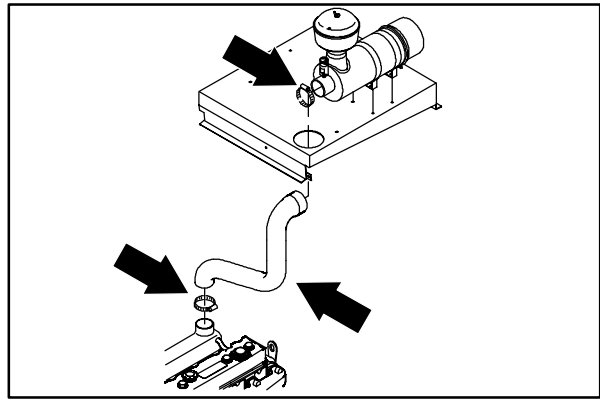

TO INSTALL ENGINE

FOR SAFETY: Before Leaving Or Servicing Machine; Stop On Level Surface, Set Parking Brake., Turn Off Machine And Remove Key.

1. Using an overhead hoist, hook a chain through the two pick-up points on the top of the engine. Position the engine into the engine compartment.
2. Lower the engine assembly carefully down onto the motor mounts.

NOTE: Make sure the hoses, wire harness, exhaust pipe and propel pump are pulled back out of the way when lowering engine assembly into place.

3. Reinstall the M12 hex screws into the front motor mounts. Tighten to 64 - 83 Nm (47 - 61 ft lb).
4. Reinstall the rear motor mount on the bellhousing plate using the two M10 hex screws. Tighten to 37 - 48 Nm (26 - 34 ft lb).
5. Reinstall the propel pump in the back of the bellhousing. Reuse the M12 hex screws. Tighten to 64 - 83 Nm (47 - 61 ft lb).

NOTE: Make sure the splines on pump line up with splines in coupler when installing pump.

6. Reinstall the exhaust pipe back on the manifold using four M10 hex screws. Tighten to 52 - 67 Nm (39 - 50 ft lb).

NOTE: Make sure steel gasket is in place when installing exhaust pipe.

7. Reconnect the fuel lines.
8. Reconnect the ground cable from the bellhousing to the machine frame.

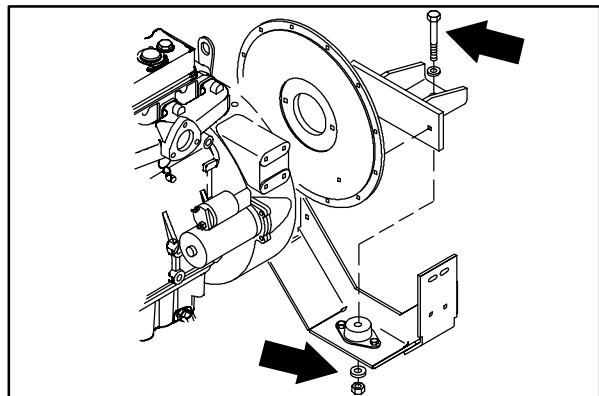
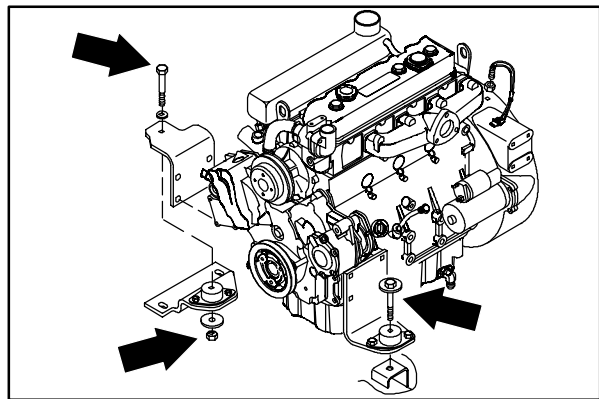
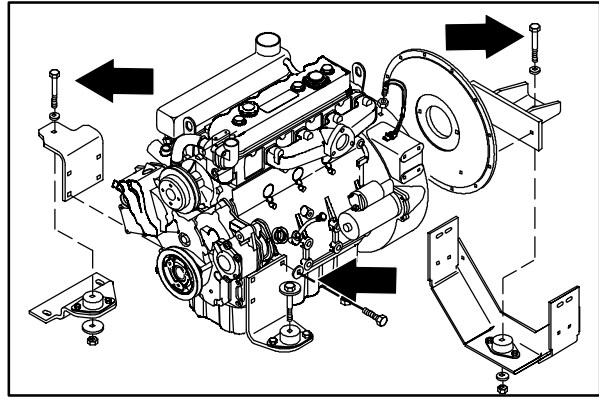

ENGINE-D-PERKINS 700 SERIES

9. Reconnect the oil drain hose to the oil pan and fill the engine with the proper grade of engine oil.
10. Reconnect the main wire harness to the engine components, alternator, starter, oil switch, and the temperature sender.
11. Reinstall the radiator hoses to engine and fill the radiator with antifreeze coolant.
12. Reconnect the battery cables.
13. Jack up the rear of the machine.

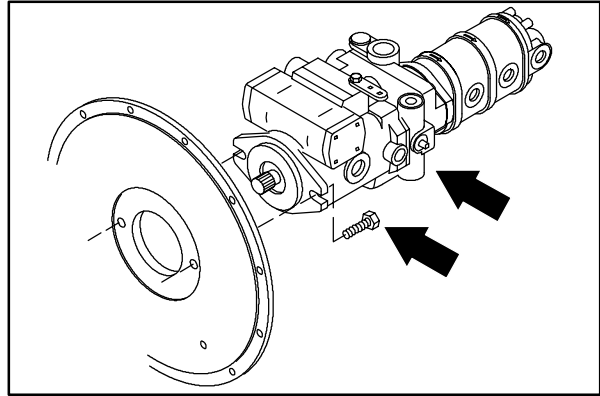

FOR SAFETY: Block machine tires before jacking machine up. Jack machine up at designated locations only. Block machine up with jack stands

14. Start the engine and check for fuel or hydraulic oil leaks.
15. Reinstall the engine covers and side door.
16. Reinstall the air cleaner assembly.
17. Lower the machine and operate. Check for proper operation.

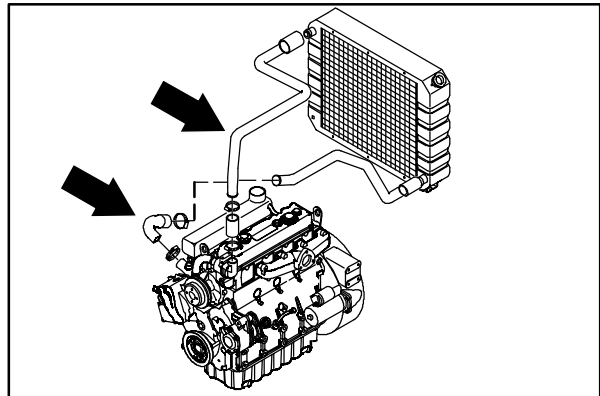

LUBRICATION

Check the engine oil level daily. Change the engine oil and oil filter every 100 hours of machine operation. Use 10W30 SAE-CC/CD rated engine oil.

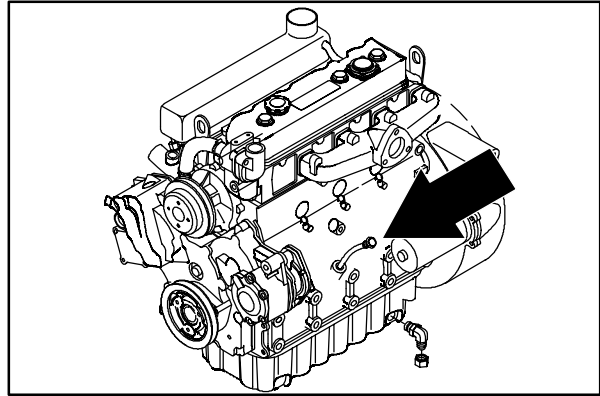

The engine oil drain is located on the left side of the machine inside the main brush compartment.

Fill the engine with oil to the level indicated on the oil dipstick. The engine oil capacity is 6 L (6.3 qt) including the oil filter.

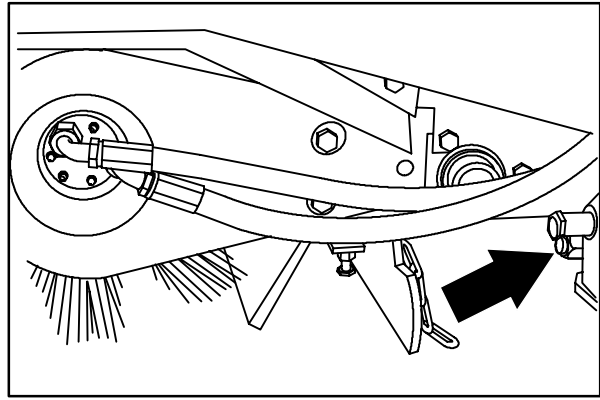

COOLING SYSTEM

Check the radiator coolant level every 100 hours of operation. Use clean water mixed with a permanent-type, ethylene glycol antifreeze to a -34°C (-30°F) rating.

FOR SAFETY: When Servicing Machine, Avoid Contact With Hot Engine Coolant.

ATTENTION! Never pour cold water or cold antifreeze into the radiator of an overheated engine. Allow the engine to cool down to avoid cracking the cylinder head or block. Keep the engine running while adding water.

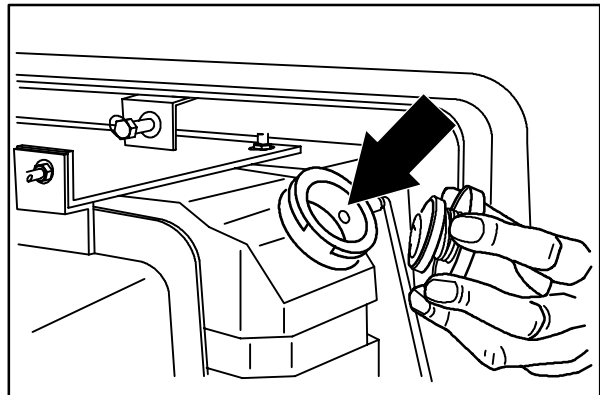

ENGINE-D-PERKINS 700 SERIES

Clean the radiator fins every 100 hours of operation.

Check the radiator hoses and clamps every 200 hours of operation. Tighten the clamps if they are loose. Replace the hoses and clamps if the hoses are cracked, harden, or swollen.

Check the radiator core exterior and hydraulic cooler fins for debris every 100 hours of operation. Blow or rinse all dust, which may have collected on the radiator, in through the grille and radiator fins, opposite the direction of normal air flow. The grille and hydraulic cooler open for easier cleaning. Be careful not to bend the cooling fins when cleaning. Clean thoroughly to prevent the fins becoming encrusted with dust. Clean the radiator and cooler only after the radiator has cooled to avoid cracking.

FOR SAFETY: When Servicing Machine, Wear Eye And Ear Protection When Using Pressurized Air Or Water.

Flush the radiator and the cooling system every 400 hours of operation, using a dependable cleaning compound.

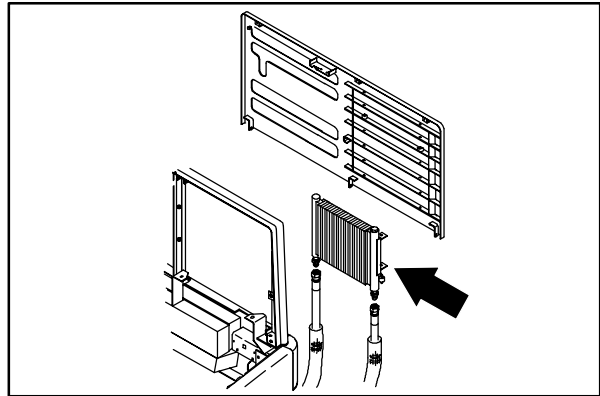
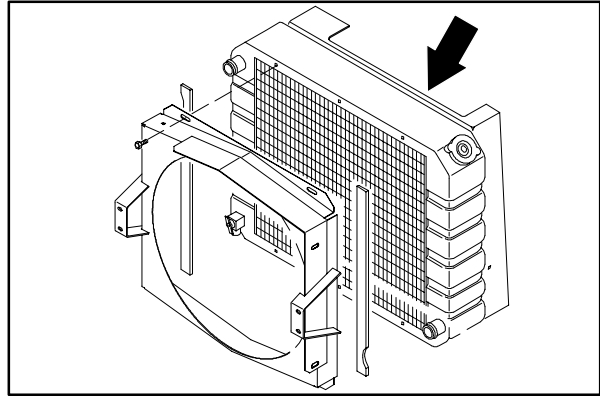

AIR INTAKE SYSTEM

AIR FILTER INDICATOR

The air filter indicator shows when to clean or replace the air filter element. Check the indicator daily. The indicator's red line will move as the air filter element fills with dirt. Do not clean or replace the air filter element until the red line reaches 5 kPa (20 in H₂O) and the "SERVICE WHEN RED" window is filled with red. The indicator's red line may return to a lower reading on the scale when the engine shuts off. The red line will return to a correct reading after the engine runs for a while.

Reset the air filter indicator by pushing the reset button on the end of the indicator after cleaning or replacing the air filter element.

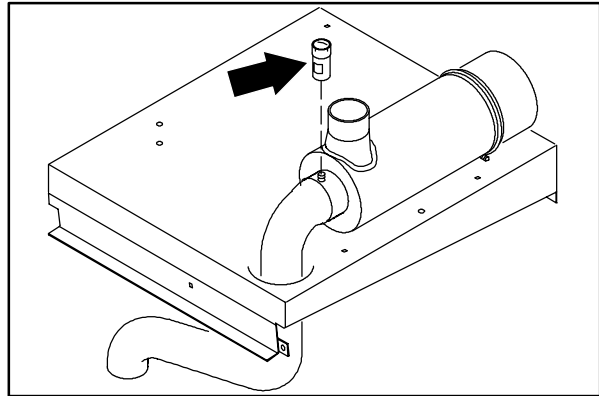
**AIR FILTER**

The engine air filter housing has a dust cap and a dry cartridge-type air filter element. Empty the dust cap daily. The air filter must be replaced whenever the filter element is damaged or has been cleaned three times.

Machines with the heavy duty air filter option have a safety element. It is inside the standard element. Replace, do not clean this element after the regular element has been damaged or cleaned three times.

Service the air filter element only when the air filter indicator shows restriction in the air intake system. Do not remove the air filter element unless it is restricting air flow.

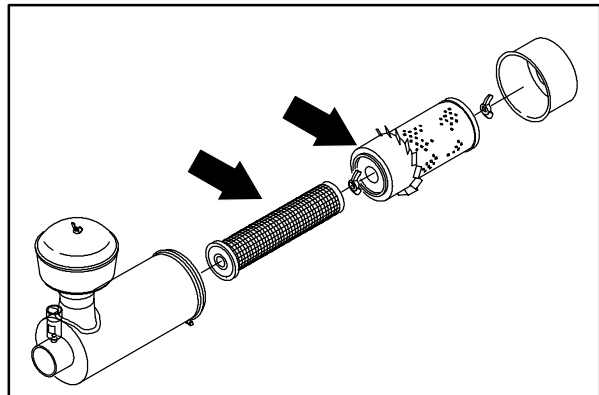

TO REPLACE AIR FILTER ELEMENT

1. Stop the engine and set the machine parking brake.

FOR SAFETY: Before Leaving Or Servicing Machine; Stop On Level Surface, Set Parking Brake, Turn Off Machine And Remove Key.

2. Locate the air cleaner assembly on top of the engine cover.
3. Unscrew the clamp ring on the filter.
4. Remove the dust cap.
5. Empty the dust cap.
6. Remove the filter wing nut.
7. Gently pull the filter element out of the filter housing.
8. Clean the interior of the air cleaner housing with a damp cloth. Clean the element housing sealing surfaces.
9. Using an air hose, direct dry, clean air maximum 205 kPa (30 psi) up and down pleats on the inside of the filter. Do not rap, tap, or pound dust out of the element.

FOR SAFETY: When Servicing Machine, Wear Eye And Ear Protection When Using Pressurized Air Or Water.

10. After cleaning the air filter element, inspect it for damage by placing a bright light inside. The slightest rupture requires replacement of the filter. Clean and inspect the seals on the ends of the element. They should be unbroken and flexible. Remember to replace the element after cleaning it three times.
11. Install the new or cleaned filter element so the fins on the element are at the intake end of the air cleaner. Be careful not to damage the fins. Make sure the element is seating evenly. Tighten the element wing nut.
12. Install the dust cap with the arrows pointing up. Tighten the clamp ring to hold it in place. Check all intake hose connections for leaks or abrasion.
13. Reset the air filter restriction indicator.

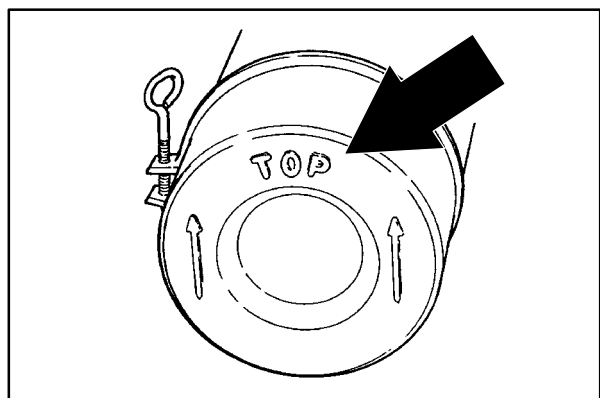
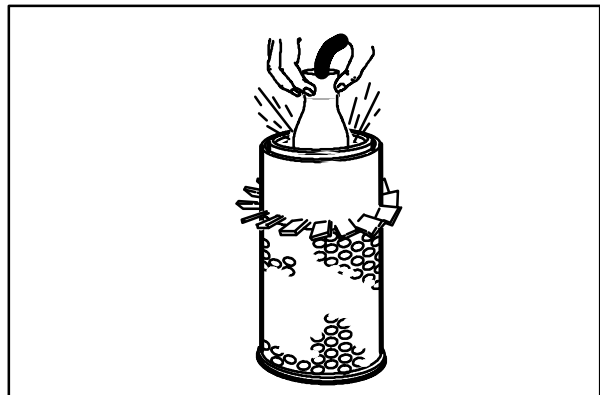
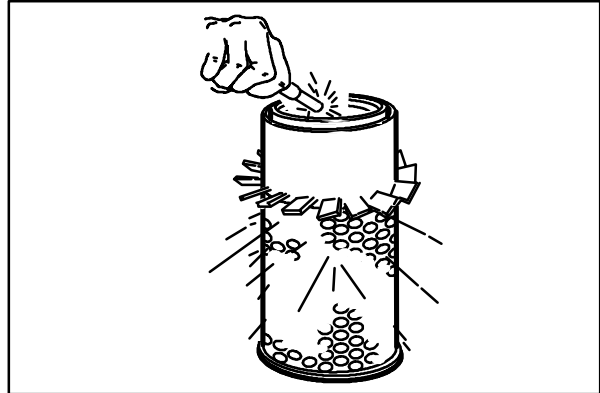

FUEL SYSTEM - DIESEL

DIESEL FUEL SYSTEM

The diesel fuel system is made up of six basic components which are: fuel tank, in-line fuel filter, in-line fuel pump, fuel filter/water trap, injection pump, and injectors.

Fuel flows from the fuel tank through the in-line fuel filter, into the in-line pump, into the fuel/water trap-filter, and into the injector pump. The water trap-filter separates water and impurities from the fuel. From the fuel water trap-filter, fuel is drawn through the electric fuel pump and pumped to the injection pump. The injection pump pressurizes and sends fuel to the injectors. The injectors atomize and inject proper amounts of fuel into the combustion chamber at the proper times. Excess fuel is returned to the fuel tank through an overflow pipe.

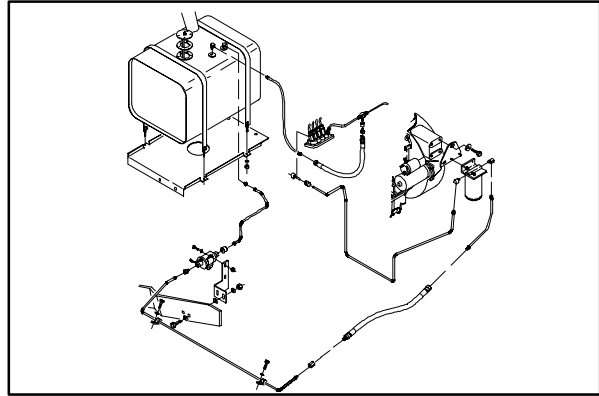

FUEL FILTER/WATER SEPARATOR

The fuel filter/water separator cartridge filters impurities from the fuel. It is located at the rear of the engine, near the starter.

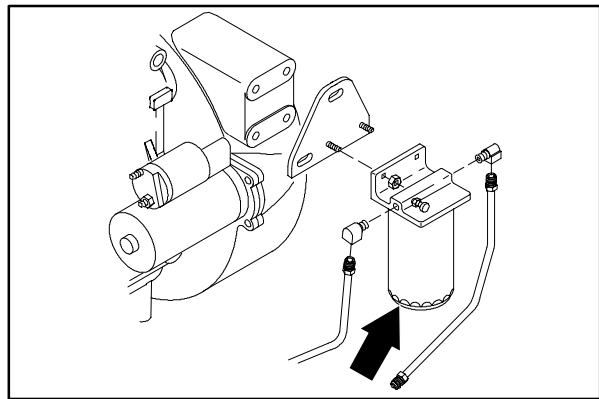

TO REPLACE THE FUEL FILTER CARTRIDGE

1. Stop the engine and set the machine parking brake.

FOR SAFETY: Before Leaving Or Servicing Machine; Stop On Level Surface, Set Parking Brake, And Turn Off Machine.

2. Open the left side and top engine access doors.
3. Loosen the unit vent plug and open the water trap drain to drain diesel fuel.
4. Remove the filter cartridge from the filter head.
5. Lubricate the o-ring of the new filter cartridge and spin it onto the filter head.
6. Bleed the fuel lines of air as described in TO PRIME FUEL SYSTEM.

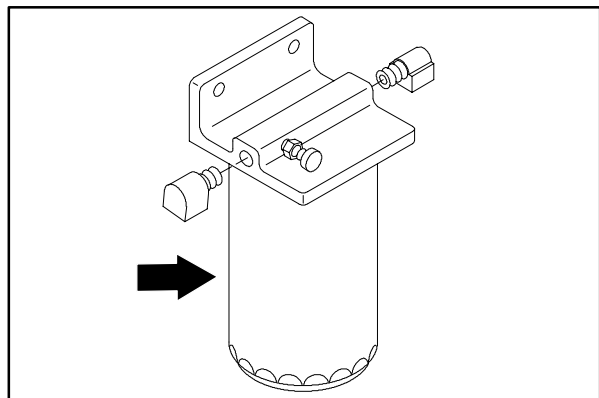

ENGINE-D-PERKINS 700 SERIES

IN-LINE FILTER

The fuel system on the 800/810 diesel includes an in-line fuel filter. This filter is ahead of the fuel pump and is used to filter any impurities before they reach the pump.

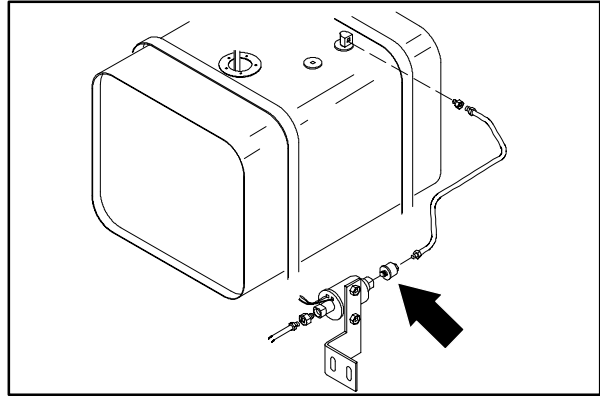

IN-LINE FUEL PUMP

The in-line fuel pump is used to pull fuel from the tank, through the in-line filter, and into the fuel/water separator. The in-line fuel pump is electric and runs off the 12VDC battery of the machine.

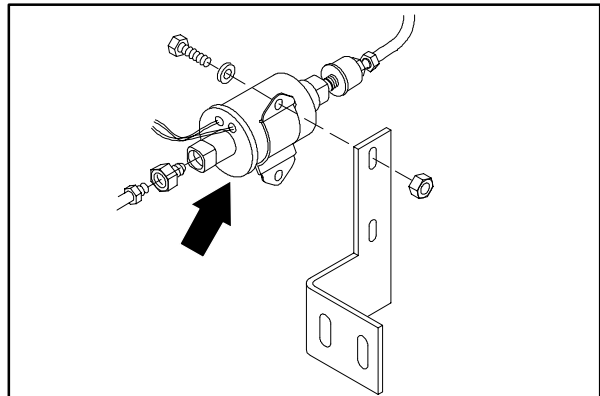

FUEL LINES

Check the fuel lines every 50 hours of operation. If the clamp band is loose, apply oil to the screw of the band, and securely tighten the band.

Portions of the fuel line system are made of rubber. The fuel lines may become worn out whether the engine has been used much or not. Replace the fuel lines and clamp bands every two years.

If the fuel lines and clamp bands are found worn or damaged before two years time, replace or repair them at once. Bleed the fuel system after replacement of any of the fuel lines, see TO PRIME THE FUEL SYSTEM. When the fuel lines are not installed, plug both ends with clean cloth or paper to prevent dirt from entering the lines. Dirt in the lines can cause fuel injection pump malfunction.

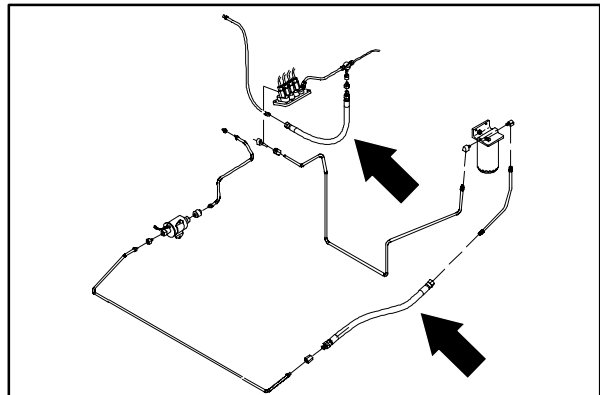

PRIMING FUEL SYSTEM

Priming the fuel system removes pockets of air in the fuel lines and fuel components. Air in the fuel system will prevent smooth engine operation.

Prime the fuel system after running out of fuel, changing fuel filter elements or repairing a fuel system component.

TO PRIME FUEL SYSTEM

FOR SAFETY: Before Leaving Or Servicing Machine; Stop On Level Surface, Set Parking Brake, And Turn Off Machine.

1. Stop the engine and set the machine parking brake.
2. Fill the fuel tank.
3. Open the side and top engine access doors.
4. Open the air vent on top of the fuel filter mounted on the bellhousing.
5. Start the engine, operate it for one minute, then stop it; or operate the starter motor in ten-second intervals until a steady stream of fuel flows from the vent.
6. Close the air vent.
7. Close the access doors.

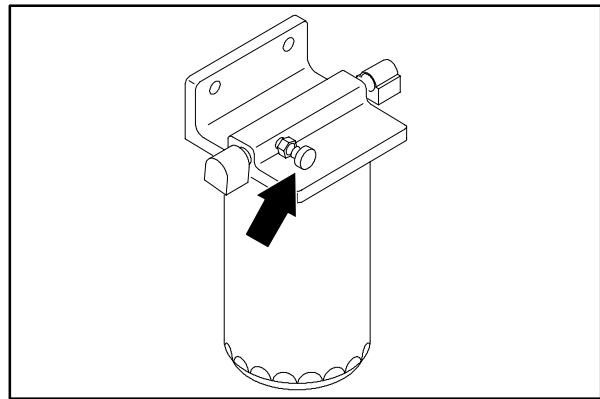

ENGINE ELECTRICAL SYSTEM

TO REPLACE ENGINE STARTER

FOR SAFETY: Before Leaving Or Servicing Machine; Stop On Level Surface, Set Parking Brake, And Turn Off Machine.

1. Open the engine cover and side door.
2. Disconnect battery cables from machine.



WARNING: Always disconnect battery cables from machine before working on electrical components.

3. The engine starter can be accessed from the engine compartment
4. Remove the wires attached to the starter. Label the wires to make sure they are returned to the proper location in the re-assembly procedure.
5. Remove the three M10 hex screws holding the starter to the engine bellhousing. Remove the starter from the machine.
6. Reinstall the starter in the bellhousing. Tighten the M10 hex screws to 37 - 48 Nm (26-34 ft lb).
7. Reconnect the wires to the new starter. See schematic in the ELECTRICAL section.
8. Reconnect the battery and start the machine. Check for proper starter operation.

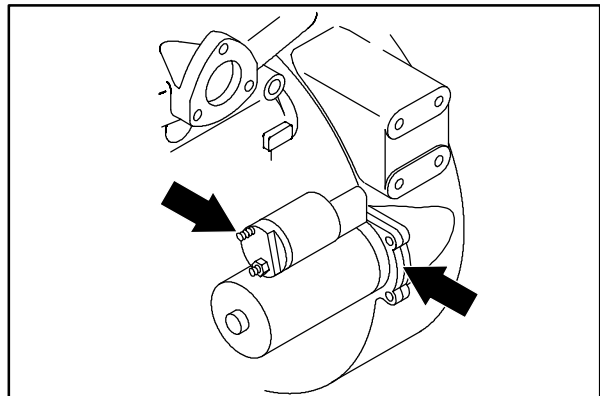
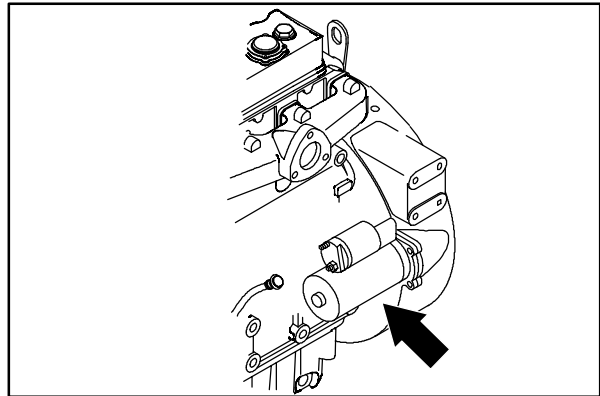
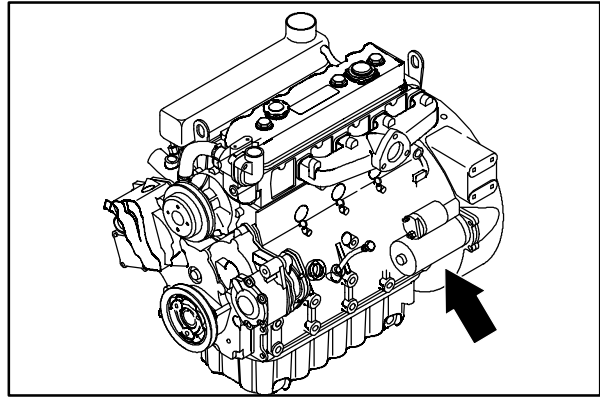

TO REPLACE ENGINE ALTERNATOR

FOR SAFETY: Before Leaving Or Servicing Machine; Stop On Level Surface, Set Parking Brake., Turn Off Machine And Remove Key.

1. Open the engine cover and side door.
2. Disconnect battery cables from machine.



WARNING: Always disconnect battery cables from machine before working on electrical components.

3. The engine alternator is accessed from the left side of the engine compartment. Remove the M8 hex screw holding the alternator to the **top** mounting bracket.
4. Loosen the M10 hex screw and nyloc nut holding the alternator to the **bottom** mounting bracket. Pivot the alternator in and remove the V-belt.
5. Remove the wires attached to the back of the alternator.
6. Remove the M10 hex screw and nyloc nut holding the alternator to the **bottom** mounting bracket. Remove the alternator from the machine.
7. Install the new alternator in the machine. Reinstall the M10 screw in the lower mount hole and the M8 in the upper mount hole.
8. Position the V-belt over the alternator pulley. Pull the alternator tight and tighten the hardware. Tighten the M8 hex screw to 18 - 24 Nm (15-20 ft lb). Tighten the M10 hex screw to 37 - 48 Nm (26-34 ft lb).
9. Check the V-belt for proper tension. See ENGINE ALTERNATOR BELT instructions.
10. Reconnect the wires to the new alternator. See schematic in the ELECTRICAL section.
11. Reconnect the battery and start the machine. Check for proper alternator operation.

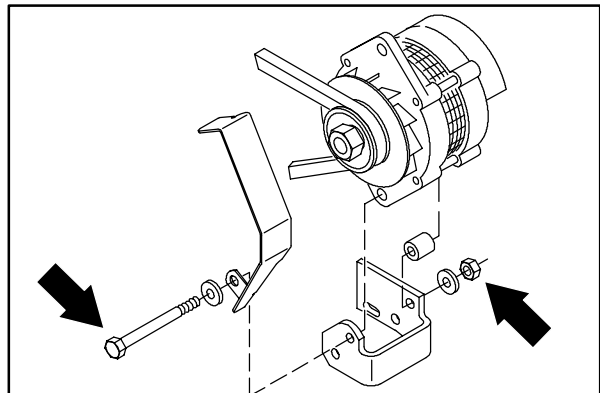
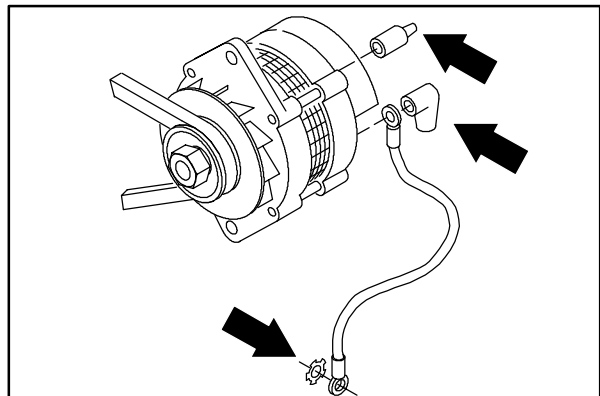
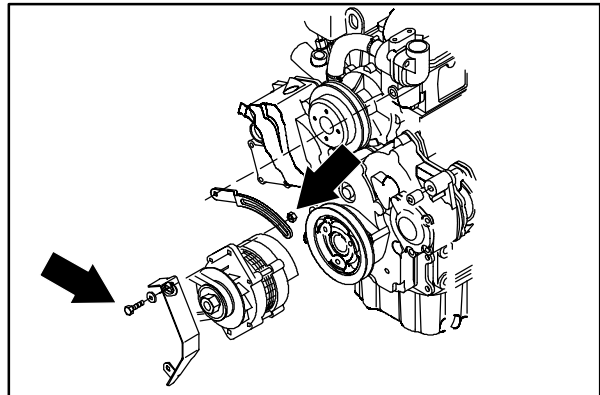
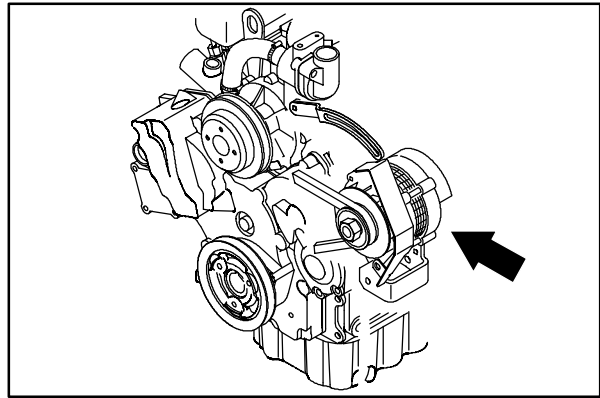

ENGINE-D-PERKINS 700 SERIES

ENGINE ALTERNATOR BELT

The engine alternator belt is driven by the engine crankshaft pulley and drives the alternator pulley. Proper belt tension is 13 mm (0.50 in) from a force of 4 to 5 kg (8 to 10 lb) applied at the mid-point of the longest span.

Check and adjust the belt tension every 100 hours of operation.

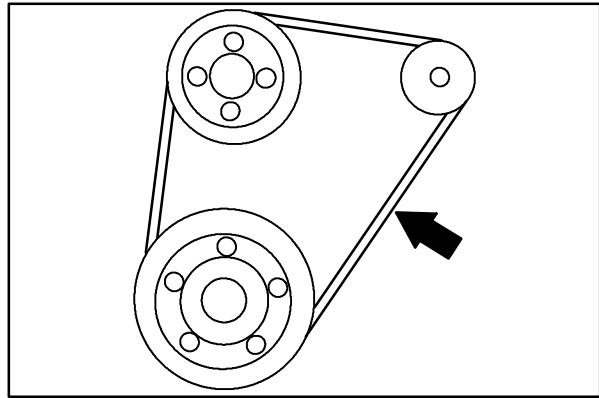



TENNANT COMPANY
 Technical Publications #15
 701 North Lilac Drive
 P.O. Box 1452
 Minneapolis, MN 55440-9947

POSTAGE WILL BE PAID BY ADDRESSEE

BUSINESS REPLY MAIL
 FIRST CLASS MAIL PERMIT NO. 94 MINNEAPOLIS, MN

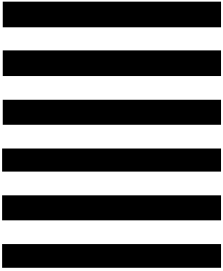

NO POSTAGE
 NECESSARY
 IF MAILED
 IN THE
 UNITED STATES

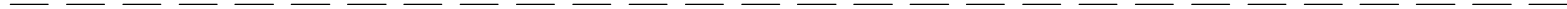

Fold along dotted lines

Tape here





TENNANT COMPANY
 Technical Publications #15
 701 North Lilac Drive
 P.O. Box 1452
 Minneapolis, MN 55440-9947

POSTAGE WILL BE PAID BY ADDRESSEE

BUSINESS REPLY MAIL
 FIRST CLASS MAIL PERMIT NO. 94 MINNEAPOLIS, MN



NO POSTAGE
 NECESSARY
 IF MAILED
 IN THE
 UNITED STATES

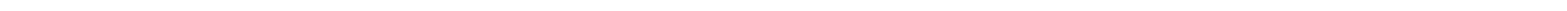
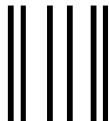

Fold along dotted lines

Tape here

