

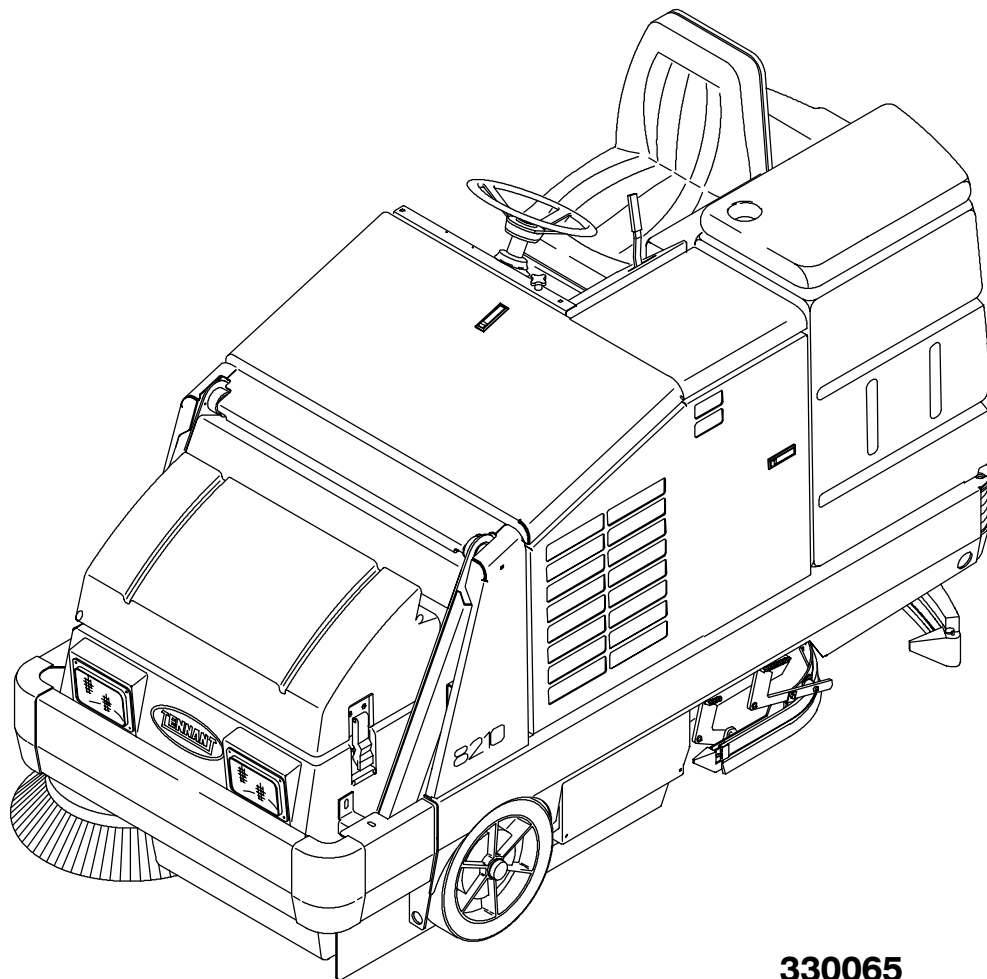

# 8200/8210

Gas/LP/Diesel  
Service Manual



330065  
Rev. 03 (3-02)





This service manual is intended to be an aid for the disassembly and reassembly of your TENNANT Model 8200/8210 sweeper/scrubber.

The set is organized into 8 major groups: General Information, Chassis, Sweeping, Scrubbing, Electrical, Hydraulics, Engine-G/LP, and Engine-D.

**General Information:** Safety precautions, machine transport, machine jacking, machine storage, chassis lubrication, machine specifications, and machine maintenance chart.

**Chassis:** Tire/wheel replacement, brake adjustment and replacement, steering adjustment and replacement, and machine cab information.

**Sweeping:** Hopper repair/replacement, brush repair/replacement, skirt/seal repair/replacement, and sweeping troubleshooting.

**Scrubbing:** Scrub head repair/replacement, brush repair/replacement, skirt/seal repair/replacement, squeegee repair/replacement, solution and recovery tank repair/replacement, and scrubbing troubleshooting.

**Electrical:** Battery maintenance and replacement, electrical schematics, and electrical troubleshooting.

**Hydraulics:** Valve replacement, motor replacement/repair, cylinder replacement/repair, pump replacement/repair, filter replacement, hydraulic schematic, and hydraulic troubleshooting.

**Engine - G/LP:** Air filter replacement, oil changing, cooling system maintenance/repair, engine repair, engine troubleshooting, engine removal, and engine repairs.

**Engine - D:** Air filter replacement, oil changing, cooling system maintenance/repair, engine repair, engine troubleshooting, engine removal, and engine repairs.

Manual Number - 330065

Revision: 03

Published: 3-02



**CALIFORNIA PROPOSITION 65 WARNING:**

**Engine exhaust from this product contains chemicals known to the State of California to cause cancer, birth defects, or other reproductive harm.**

**CONTENTS**

	Page
SAFETY PRECAUTIONS .....	1-3
SPECIFICATIONS .....	1-7
GENERAL MACHINE PERFORMANCE	1-7
POWER TYPE .....	1-8
STEERING .....	1-9
HYDRAULIC SYSTEM .....	1-9
BRAKING SYSTEM .....	1-9
TIRES .....	1-9
MACHINE DIMENSIONS .....	1-10
MAINTENANCE .....	1-12
MAINTENANCE CHART .....	1-12
PUSHING, TOWING, AND TRANSPORTING	
THE MACHINE .....	1-14
PUSHING OR TOWING THE	
MACHINE .....	1-14
TRANSPORTING THE MACHINE ...	1-15
MACHINE JACKING .....	1-17
STORING MACHINE .....	1-17
MACHINE TROUBLESHOOTING .....	1-18
HARDWARE INFORMATION .....	1-20
STANDARD BOLT TORQUE CHART	1-20
METRIC BOLT TORQUE CHART ...	1-20
BOLT IDENTIFICATION .....	1-20
THREAD SEALANT AND LOCKING	
COMPOUNDS .....	1-20
HYDRAULIC FITTING INFORMATION ..	1-21
HYDRAULIC TAPERED PIPE FITTING	
(NPT) TORQUE CHART .....	1-21
HYDRAULIC TAPERED SEAT FITTING	
(JIC) TORQUE CHART .....	1-21
HYDRAULIC O-RING FITTING	
TORQUE CHART .....	1-21



## SAFETY PRECAUTIONS

The following precautions are used throughout this manual as indicated in their description:



**WARNING:** To warn of hazards or unsafe practices that could result in severe personal injury or death.

**FOR SAFETY:** To identify actions that must be followed for safe operation of equipment.

The machine is suited to sweep disposable debris. Do not use the machine other than described in this Operator Manual. The machine is not designed for use on public roads.

The following information signals potentially dangerous conditions to the operator or equipment:

**FOR SAFETY:**

1. **Do not operate machine:**
  - Unless trained and authorized.
  - Unless operator manual is read and understood.
  - If it is not in proper operating condition.
  - In flammable or explosive areas unless designed for use in those areas.
  - In areas with possible falling objects unless equipped with overhead guard.
2. **Before starting machine:**
  - Check for fuel, oil, and liquid leaks.
  - Keep sparks and open flame away from refueling area.
  - Make sure all safety devices are in place and operate properly.
  - Check brakes and steering for proper operation.
3. **When starting machine:**
  - Keep foot on brake and directional pedal in neutral.
4. **When using machine:**
  - Use brakes to stop machine.
  - Go slow on inclines and slippery surfaces.
  - Use care when reversing machine.
  - Move machine with care when hopper is raised.
  - Make sure adequate clearance is available before raising hopper.
5. **Before leaving or servicing machine:**
  - Stop on level surface.
  - Set parking brake.
  - Turn off machine and remove key.
6. **When servicing machine:**
  - Avoid moving parts. Do not wear loose jackets, shirts, or sleeves.
  - Block machine tires before jacking machine up.
  - Jack machine up at designated locations only. Block machine up with jack stands.
  - Use hoist or jack that will support the weight of the machine.
  - Wear eye and ear protection when using pressurized air or water.
  - Disconnect battery connections before working on machine.
  - Avoid contact with battery acid.
  - Avoid contact with hot engine coolant.
  - Allow engine to cool.
  - Keep flames and sparks away from fuel system service area. Keep area well ventilated.
  - Use cardboard to locate leaking hydraulic fluid under pressure.
  - Use Tennant supplied or approved replacement parts.
7. **When loading/unloading machine onto/off truck or trailer:**
  - Turn off machine.
  - Use truck or trailer that will support the weight of the machine.
  - Use winch. Do not drive the machine onto/off the truck or trailer unless the load height is 380 mm (15 in) or less from the ground.
  - Set parking brake after machine is loaded.
  - Block machine tires.
  - Tie machine down to truck or trailer.
- Do not carry passengers on machine.
- Always follow safety and traffic rules.
- Report machine damage or faulty operation immediately.
- Follow mixing and handling instructions on chemical containers.

## GENERAL INFORMATION

---

 **WARNING: Engine emits toxic gases. Severe respiratory damage or asphyxiation can result. Provide adequate ventilation. Consult with your regulatory authorities for exposure limits. Keep engine properly tuned.**

 **WARNING: Raised hopper may fall. Engage hopper support bar.**

 **WARNING: Lift arm pinch point. Stay clear of hopper lift arms.**

 **WARNING: Moving belt and fan. Keep away.**

 **WARNING: Flammable materials can cause an explosion or fire. Do not use flammable materials in tank(s).**

 **WARNING: Flammable materials or reactive metals can cause explosion or fire. Do not pick up.**

The following safety labels are mounted on the machine in the locations indicated. If these or any label becomes damaged or illegible, install a new label in its place.

**EMISSIONS LABEL - LOCATED ON THE SIDE PANEL OF THE OPERATOR COMPARTMENT.**

**FLAMMABLE SPILLS LABEL - LOCATED ON THE SIDE PANEL OF THE OPERATOR COMPARTMENT.**

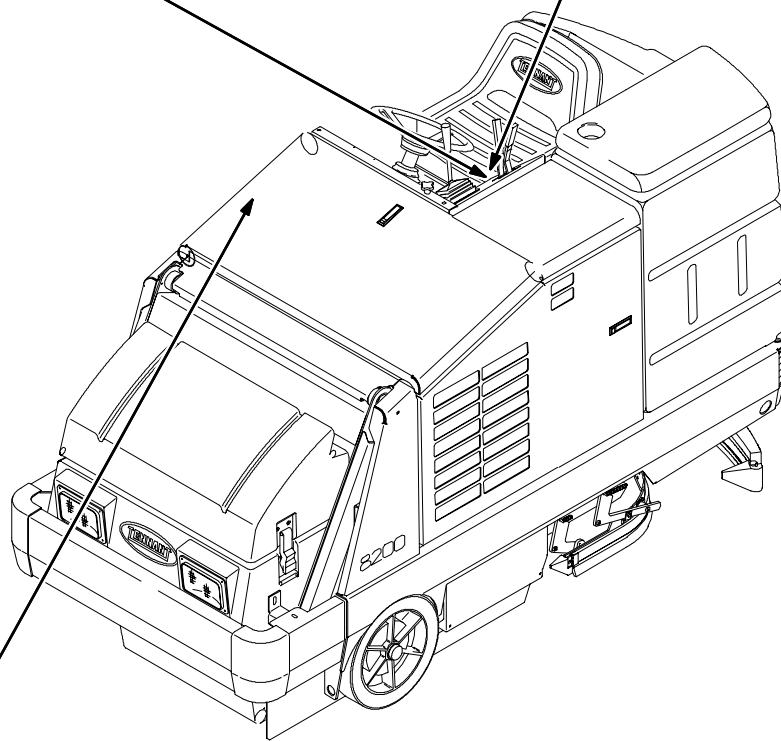

**ENGINE FAN AND BELT LABEL - LOCATED ON THE RADIATOR SHROUD.**

# GENERAL INFORMATION

**FLAMMABLE MATERIALS LABEL - LOCATED ON THE SOLUTION TANK COVER & ON THE BATTERY TRAY ON MACHINES WITH THE DETERGENT TANK OPTION.**

**FOR SAFETY LABEL - LOCATED ON THE SIDE PANEL OF THE OPERATOR COMPARTMENT.**

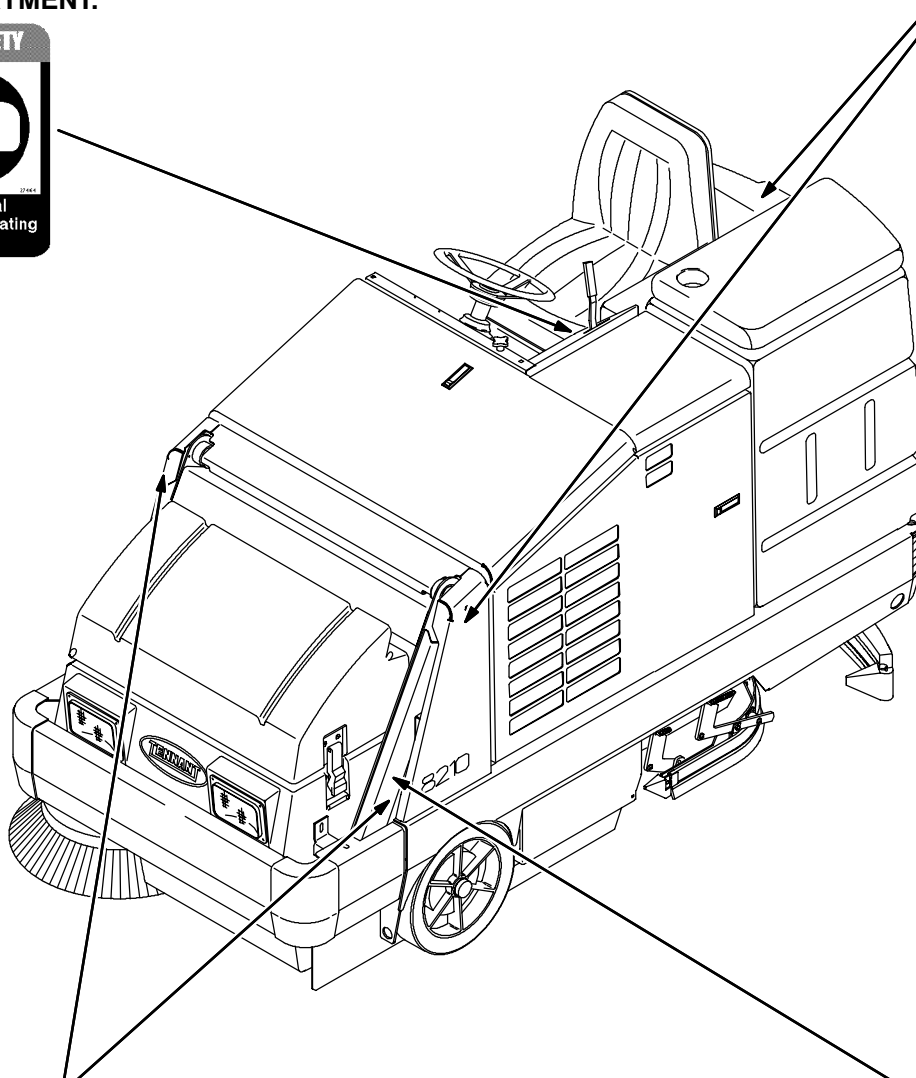

351551

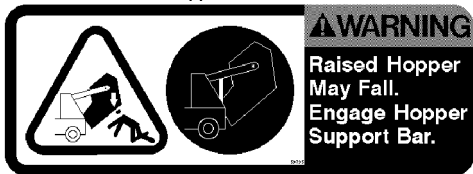

**HOPPER SUPPORT BAR LABEL - LOCATED ON THE HOPPER SUPPORT BAR AND ON BOTH HOPPER LIFT ARMS.**



**HOPPER LIFT ARMS LABEL - LOCATED ON BOTH HOPPER LIFT ARMS.**



**SPECIFICATIONS**

**GENERAL MACHINE DIMENSIONS/CAPACITIES**

Item	Dimension/capacity
Length	2553 mm (100.5 in)
Width with side brush	1397 mm (55 in)
Width with Maxpath™ side brush	1473 mm (58 in)
Height	1466 mm (57.7 in)
Height with overhead guard	2083 mm (82 in)
Track	1083 mm (42.6 in)
Wheelbase	1511 mm (59.5 in)
Main sweeping brush diameter	355 mm (14 in)
Main sweeping brush length	914 mm (36 in)
Scrub brush diameter - 2 brushes	508 mm x 2 brushes (20 in x 2 brushes)
Scrub brush diameter - 3 brushes (option)	406 mm x 3 brushes (16 in x 3 brushes) (option)
Side brush diameter	584 mm (23 in)
Sweeping path width	914 mm (36 in)
Sweeping path width with side brush	1270 mm (50 in)
Squeegee width	1219 mm (48 in)
Scrubbing path width - two scrub brushes	1016 mm (40 in)
Scrubbing path width - three scrub brushes (option)	1219 mm (48 in)
Main sweeping brush pattern width	64 mm (2.5 in) - adjustable
Hopper weight capacity	159 kg (350 lb)
Hopper volume capacity	220 L (7.8 ft <sup>3</sup> )
Dust filter area	5.85 m <sup>2</sup> (63 sq ft)
Solution tank	196.8 L (52 gal)
Recovery tank	265 L (70 gal)
Detergent tank	17.8 L (4.7 gal)
Total capacity with ES™ (option)	303 L (80 gal)
GVWR	1937 kg (4270 lb)
Ceiling height minimum dumping clearance	2286 mm (90 in)

**GENERAL MACHINE PERFORMANCE**

Item	Measure
Maximum forward speed	9.7 kmh (6 mph)
Maximum reverse speed	4.8 kmh (3 mph)
Minimum aisle turn width, left	3.01 m (9 ft 9 in)
Minimum aisle turn width, right	4.3 m (14 ft 10 in)
Minimum turning radius, left	0.98 m (38.75 in)
Minimum turning radius, right	1.91 m (75.25 in)
Maximum rated incline for transport of machine	(8° - 14%)
Maximum rated incline for scrubbing/sweeping	(6° - 10.5%)

## GENERAL INFORMATION

### POWER TYPE

Engine	Type	Ignition	Cycle	Aspiration	Cylinders	Bore	Stroke
Ford VSG1.3 L	Piston	Distributorless-type spark	4	Natural	4	73.94 mm (2.91 in)	75.44 mm (2.97 in)
	Displacement		Net power, governed		Net power, maximum		
	1300 cc (79 cid)		23.2 kw (32 hp) @ 2400 rpm		39.5 kw (53 hp) @ 4000 rpm		
	Fuel		Cooling system		Electrical system		
	Gasoline, 87 octane minimum, unleaded. Fuel tank: 37.9 L (10 gal)		Water/ethylene glycol antifreeze		12 V nominal		
	LPG, Fuel tank: 15 kg (33 lb) 19.5 kg (43 lb)		Total: 16.7 L (4.4 gal)		50 A alternator		
			Radiator: 6 L (1.6 gal)				
	Idle speed, no load		(Fast) governed speed, under load		Firing order		
	1200 ± 50 rpm		2400 ± 50 rpm		1-2-4-3		
	Spark plug gap		Valve clearance, cold		Engine lubricating oil with filter		
1 mm (0.04 in)		0.020 mm (0.008 in) intake 0.050 mm (0.020 in) exhaust		3.7 L (4 qt) 10W30 SAE-SG/SH			

Engine	Type	Ignition	Cycle	Aspiration	Cylinders	Bore	Stroke
Kubota V1505B-61	Piston	Diesel	4	Natural	4	78 mm	78.4 mm
	Displacement		Net power, governed		Net power, maximum		
	1498 cc (91.44 cid)		20.0 kw @ 2400 rpm (26.8 hp)		27.9 kw @ 2800 rpm (37.5 hp)		
	Fuel		Cooling system		Electrical system		
	Diesel Fuel tank: 37.9 L (10 gal)		Water/ethylene glycol antifreeze		12 V nominal		
			Total: 16.7 L (4.4 gal)		50 A alternator		
			Radiator: 6 L (1.6 gal)				
	Idle speed, no load		(Fast) governed speed, under load		Engine lubricating oil without filter		
1400 ± 25 rpm		2400 ± 25 rpm		6.15 L (6.5 qt) diesel rating <i>above</i> CD grade only			

**STEERING**

Type	Power source	Emergency steering
Rear wheel, hydraulic cylinder and rotary valve controlled	Hydraulic accessory pump	Manual

**HYDRAULIC SYSTEM**

System	Capacity	Fluid Type
Hydraulic reservoir capacity	25.4 L (6.7 gal) Fill to FULL line only	TENNANT part no. 65869 - above 7° C (45° F) TENNANT part no. 65870 - below 7° C (45° F)
Hydraulic total (all components, plumbing)	28.4 L (7.5 gal)	

**BRAKING SYSTEM**

Type	Operation
Service brakes	Mechanical drum brakes (2), one per front wheel, linkage actuated
Parking brake	Utilize service brakes, linkage actuated

**TIRES**

Location	Type	Size	Pressure
Front (2)	Solid	406 x 89 x 308 mm (16x3.5 x12.125 in)	-
Rear (1)	Solid	413 x 152 mm (16.25 x 6 in)	-

# GENERAL INFORMATION

TOP VIEW

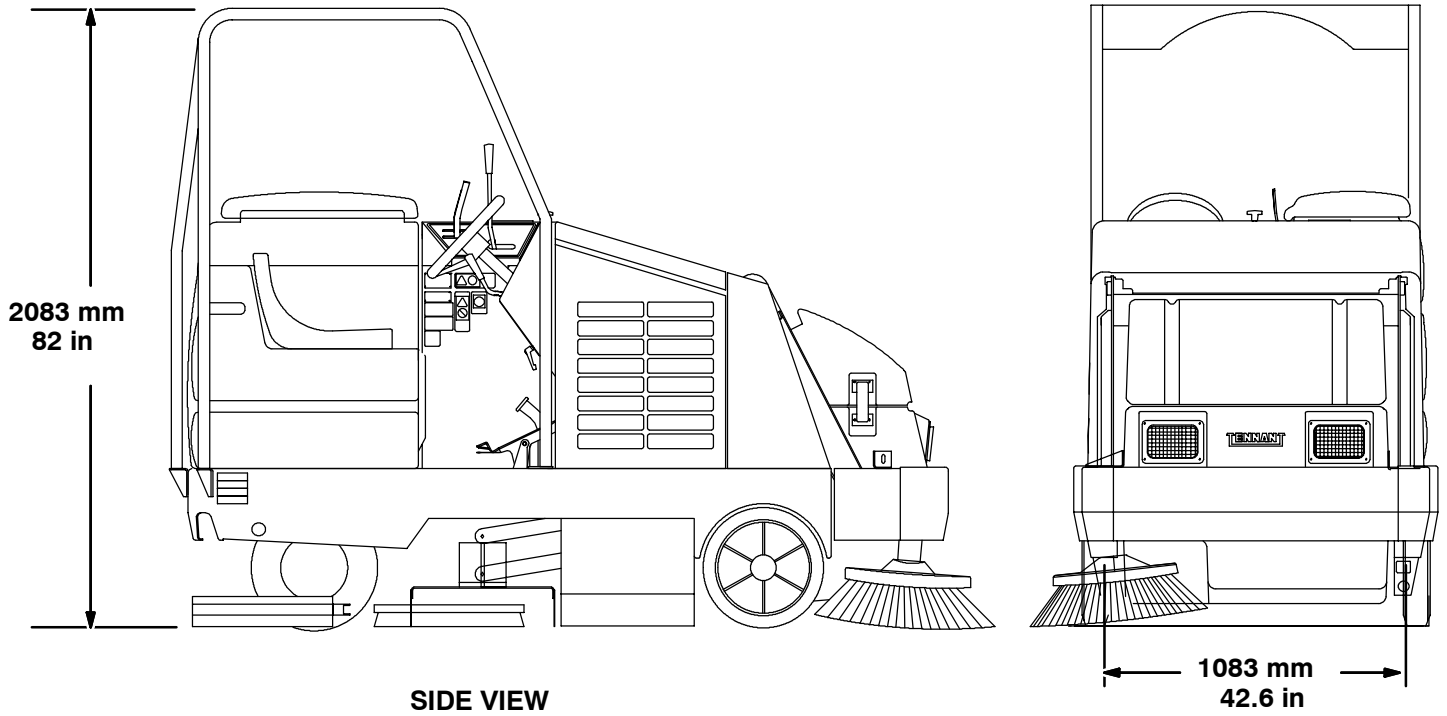
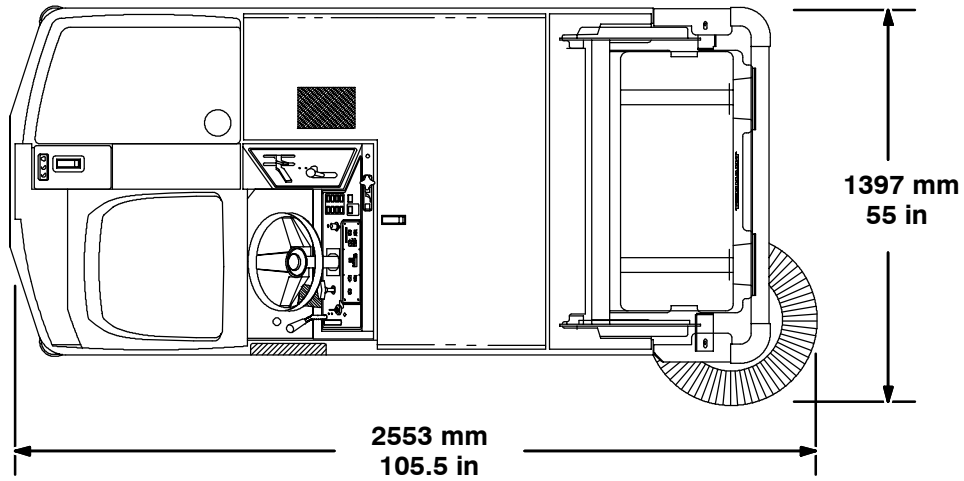

## MACHINE DIMENSIONS

351664



**MAINTENANCE**

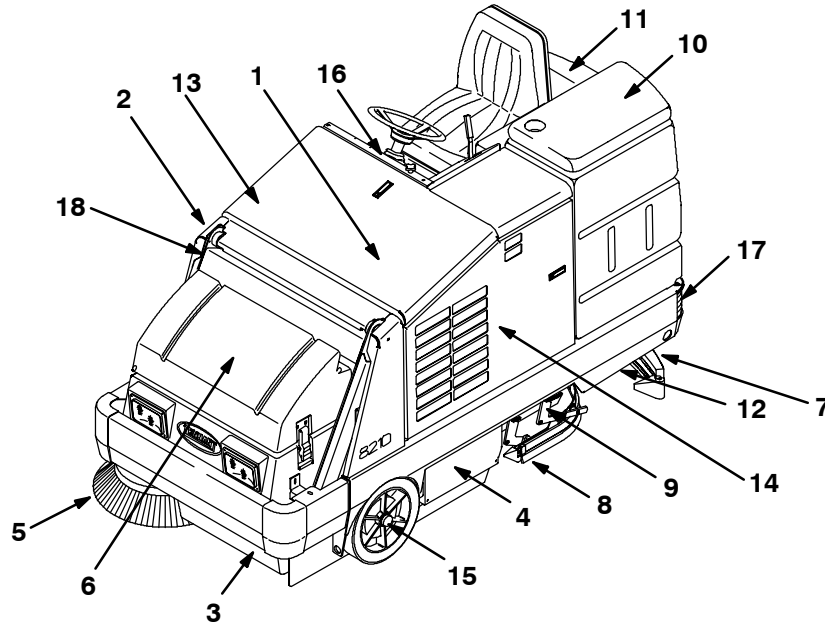

**MAINTENANCE CHART**

Interval	Key	Description	Procedure	Lubricant/ Fluid	No. of Service Points
Daily	1	Engine air filter	Check indicator	-	1
			Empty dust cap	-	1
			Clean / change filter element as necessary	-	1
	1	Engine crankcase	Check oil level	EO	1
	2	Brush compartment skirts	Check for damage, wear and adjustment	-	5
	3	Hopper lip skirts	Check for damage, wear and adjustment	-	3
	4	Main sweep brush	Check for damage, wear, and adjustment	-	1
			Check brush pattern	-	1
	5	Side brush	Check for damage, wear, and adjustment	-	1
			Check brush pattern	-	1
	6	Hopper dust filter	Shake to clean	-	2
	7	Rear Squeegee	Check for damage and wear	-	1
			Check deflection	-	1
	8	Side Squeegees	Check for damage and wear	-	2
9	Scrub brushes	Check for damage and wear	-	1	
10	Recovery tank	Clean	-	1	
	Recovery tank, ES™ mode	Clean ES™ filter	-	1	
	Solution tank, ES™ mode	Clean	-	1	
50 Hours	1	Engine crankcase	Change oil and filter element	EO	1
	4	Main sweep brush	Rotate end-for-end	-	1

## GENERAL INFORMATION

Interval	Key	Description	Procedure	Lubricant/ Fluid	No. of Service Points
100 hours	13	Radiator	Clean core exterior	-	1
			Check coolant level	WG	1
	1	Engine	Check belt tension	-	1
	6	Hopper dust filter	Check for damage, clean or re-place	-	1
	14	Hydraulic fluid reservoir	Check fluid level	HYDO	1
	15	Tires	Check all for damage, check rear tire pressure	-	3
	2,6	Main sweep brush and hopper seals	Check for damage or wear	-	8
	7	Rear squeegee	Check leveling	-	1
	10, 11	Tank cover seals	Check for damage or wear	-	2
	12	Scrub head drag link arm pivot points	Lubricate	SPL	4
200 Hours	13	Radiator hoses and clamps	Check for tightness and wear	-	2
	16	Parking brake	Check adjustment	-	1
	16	Brake pedal	Check and adjust travel	-	1
	17	Rear wheel support bearings	Lubricate	SPL	1
	18	Hopper lift arm pivots	Lubricate	SPL	2
400 Hours	1	Engine	Change fuel filter	-	2
			Clean or replace and re-gap spark plugs (G/LP)	-	2
	15	Front wheel bearings	Check, lubricate, and adjust	SPL	2
	1	Valve clearance (first 400 hours of machine use)	Check / adjust valve clearance	-	2
800 hours	1	Engine	Replace PCV valve. Clean PCV hoses, tubes, and fittings (G/LP)	-	4
			Torque intake manifold bolts	-	1
				-	8
	13	Cooling system	Flush	WG	2
	14	Hydraulic fluid reservoir	Change hydraulic fluid	HYDO	1
			Replace suction strainer		1
			Replace hydraulic breather		1
			Replace cap		1
	14	Hydraulic fluid filter	Change filter element	-	1
	-	Hydraulic hoses	Check for wear and damage	-	All
	1	Propelling motor	■Torque shaft nut	-	1
17	Rear wheel	■Torque wheel nuts	-	1	
1	Battery	■Clean and tighten battery cable connections	-	1	

### LUBRICANT/FLUID

EO . . . . Engine oil, 10W30 SAE-SG/SH only (G/LP)

EO . . . . Engine oil, diesel rating *above* CD grade only. (Diesel)

HYDO . . Tennant or approved hydraulic fluid

WG . . . . Water and permanent-type ethylene glycol anti-freeze, -34° C (-30° F)

SPL . . . . Special lubricant, Lubriplate EMB grease (Tennant part number 01433-1)

*NOTE: Also check procedures indicated (■) after the first 50-hours of operation.*

*NOTE: More frequent intervals may be required in extremely dusty conditions.*

## GENERAL INFORMATION

### PUSHING, TOWING, AND TRANSPORTING THE MACHINE

#### PUSHING OR TOWING THE MACHINE

If the machine becomes disabled, it can be pushed from the front or rear, but towed only from the rear.

The propelling pump has a bypass valve to prevent damage to the hydraulic system when the machine is being pushed or towed. This valve allows a disabled machine to be moved for a *very short distance* and at a speed to not exceed 1.6 kp/h (1 mph). The machine is NOT intended to be pushed or towed a long distance or at a high speed.

**ATTENTION! Do not push or tow machine for a long distance and without using the bypass valve, or the machine hydraulic system may be damaged.**

Turn the bypass valve 90° from the normal position before pushing or towing the machine. **The illustration shows the bypass valve in the pushing or towing position.**

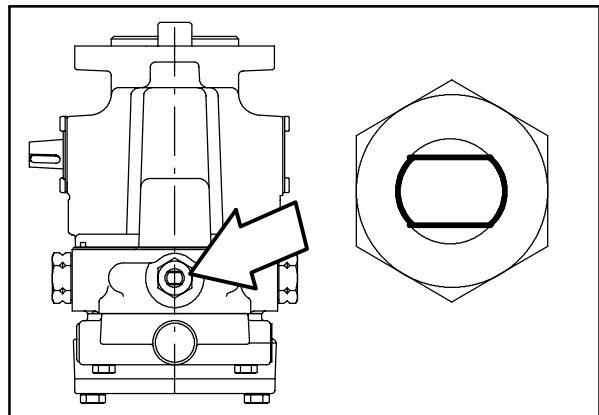
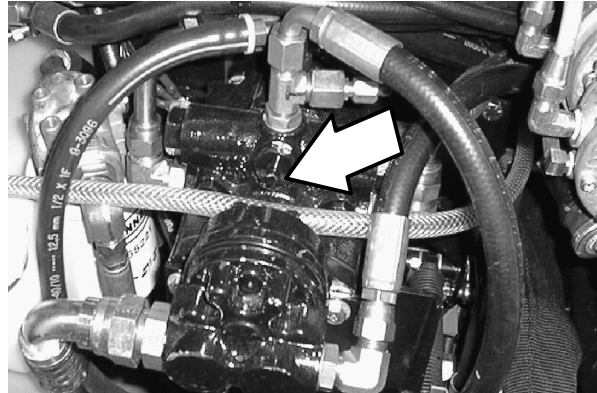



## TRANSPORTING THE MACHINE

1. Position the rear of the machine at the loading edge of the truck or trailer.

**FOR SAFETY: Use truck or trailer that will support the weight of the machine.**

*NOTE: Empty the hopper, recovery tank, and solution tank before transporting the machine.*

2. If the loading surface is not horizontal or is higher than 380 mm (15 in) from the ground, use a winch to load machine.

If the loading surface is horizontal AND is 380 mm (15 in) or less from the ground, the machine may be driven onto the truck or trailer.

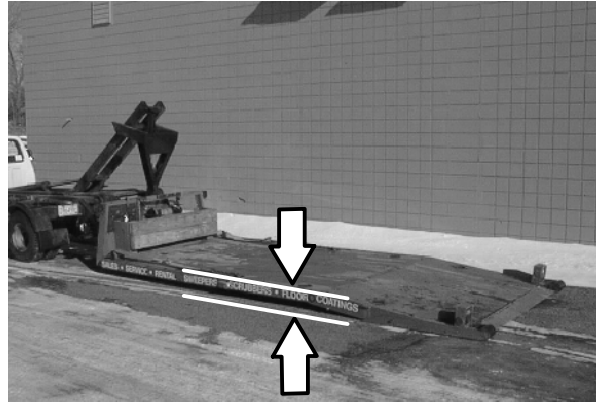

3. To winch the machine onto the truck or trailer, attach the winching chains to the rear tie down locations. The rear tie-down locations are the bottom lips at each corner of the rear bumper.



4. Turn the bypass valve 90° from the normal position before winching the machine onto the truck or trailer. See *PUSHING OR TOWING THE MACHINE* section of this manual. Make sure the machine is centered.

**FOR SAFETY: When loading machine onto truck or trailer, use winch. Do not drive the machine onto the truck or trailer unless the loading surface is horizontal AND is 380 mm (15 in) or less from the ground.**

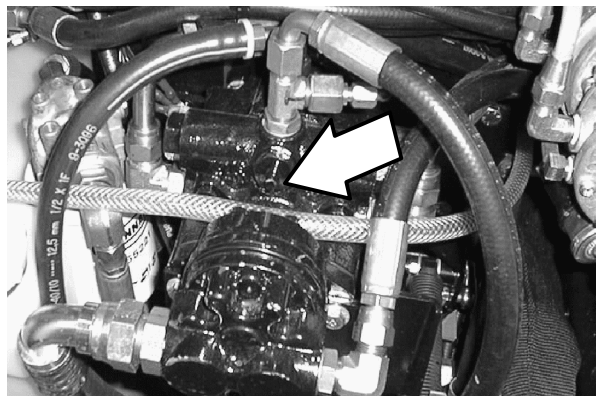

5. Position the machine onto the truck or trailer as far as possible. If the machine starts to veer off the centerline of the truck or trailer, stop and turn the steering wheel to center the machine.

## GENERAL INFORMATION

6. Set the parking brake, lower the scrub head and block the machine tires. Tie down the machine to the truck or trailer before transporting.

The front tie-down locations are the holes in the wheel pockets at the front of the machine frame.

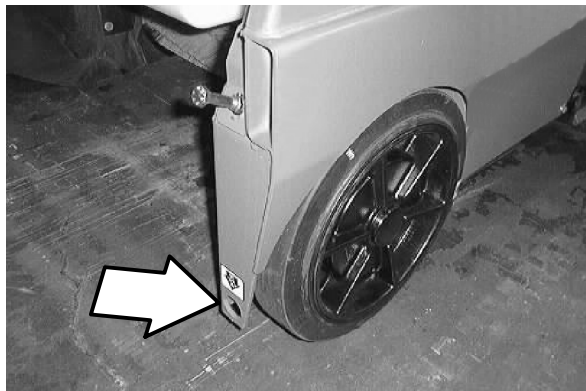

The rear tie-down locations are the bottom lips at each corner of the rear bumper.



7. If the loading surface is not horizontal or is higher than 380 mm (15 in) from the ground, use a winch to unload machine.

If the loading surface is horizontal AND is 380 mm (15 in) or less from the ground, the machine may be driven off the truck or trailer.

**FOR SAFETY: When unloading machine off truck or trailer, use winch. Do not drive the machine off the truck or trailer unless the loading surface is horizontal AND 380 mm (15 in) or less from the ground.**

---

### MACHINE JACKING

---

Empty the hopper, recovery tank, and solution tank before jacking the machine. You can jack up the machine for service at the designated locations. Use a hoist or jack that will support the weight of the machine. Always stop the machine on a flat, level surface and block the tires before jacking the machine up.

**FOR SAFETY: Before leaving or servicing machine; stop on level surface, set parking brake, turn off machine and remove key.**

The front jacking locations are on the flat bottom edge of the front of the machine frame next to the front tires.



The rear jacking location is under the left side of the rear bumper.

**FOR SAFETY: When servicing machine, jack machine up at designated locations only. Block machine up with jack stands.**

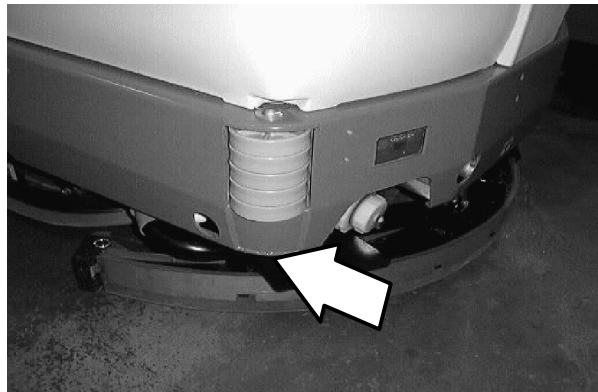

---

### STORING MACHINE

---

Before storing the machine for an extended time, the machine needs to be prepped to lessen the chance of rust, sludge, and other undesirable deposits from forming. Contact Tennant service personnel.

# GENERAL INFORMATION

## MACHINE TROUBLESHOOTING

Problem	Cause	Remedy
Excessive dusting	Brush skirts and dust seals worn, damaged, out of adjustment	Replace or adjust brush skirts or dust seals
	Hopper dust filter clogged	Shake and/or clean or replace dust filter
	Vacuum fan seal damaged	Replace vacuum seal
	Vacuum fan failure	Call TENNANT service personnel
	Thermo Sentry™ tripped	Allow Thermo Sentry™ to cool
	Hopper dump door closed	Open hopper dump door
Poor sweeping performance	Brush bristles worn	Replace brushes
	Main and side brushes not adjusted properly	Adjust main and side brushes
	Debris caught in main brush drive mechanism	Free drive mechanism of debris
	Main brush drive failure	Call TENNANT service personnel
	Side brush drive failure	Call TENNANT service personnel
	Hopper full	Empty hopper
	Hopper lip skirts worn or damaged	Replace lip skirts
	Wrong sweeping brush	Call TENNANT representative
	Hopper dump door closed	Open hopper dump door
Trailing water – poor or no water pickup.	Worn rear squeegee blades.	Rotate or replace blades
	Rear squeegee out of adjustment	Adjust rear squeegee
	Worn side squeegee blades.	Replace side squeegee blades
	Side squeegees out of adjustment	Adjust side squeegees
	Recovery tank cover not seated	Reseat tank cover
	Recovery tank cover seal worn	Replace seal
	Too much solution flow to floor	Reduce solution flow to floor
	Vacuum hose clogged	Flush vacuum hoses
	Rear squeegee tube clogged	Flush squeegee tube
	Recovery tank full	Drain recovery tank
		Check ES™ pump and filter
	Float stuck shutting off vacuum	Clean float
	Debris caught on rear squeegee	Remove debris
	Foam filling recovery tank	Empty recovery tank; use less or change detergent
	Vacuum hose to rear squeegee disconnected	Reconnect
	Vacuum-fan-to-recovery-tank-hose damaged	Replace hose
	Too much solution flow for floor conditions / machine speed	Adjust manual flow control valve to reduce total solution flow

**GENERAL INFORMATION**

<b>Problem</b>	<b>Cause</b>	<b>Remedy</b>
Little or no solution flow to the floor.	Solution tank empty.	Fill solution tank.
	Solution flow switch turned off.	Turn solution flow switch on.
	Solution supply lines plugged.	Flush solution supply lines.
	ES™ switch off.	Turn ES™ switch on.
	Manual control valve nearly closed	Open valve more
Poor scrubbing performance.	Debris caught on scrub brushes.	Remove debris.
	Improper detergent or brushes used.	Check with TENNANT representative for advice.
	Worn scrub brushes.	Replace scrub brushes.
ES™ system does not fill solution tank.	Clogged solution pump or lines.	Flush ES™ system.
	ES™ float stuck.	Clean floats of debris.
	Clogged ES™ pump filter.	Clean filter.
	Water levels too low in tanks.	Add water.

# GENERAL INFORMATION

## HARDWARE INFORMATION

The following charts state standard plated hardware tightening ranges for normal assembly applications. Decrease the specified torque by 20% when using a thread lubricant. Do not substitute lower grade hardware for higher grade hardware. If higher grade hardware than specified is substituted, tighten only to the specified hardware torque value to avoid damaging the threads of the part being threaded into, as when threading into speed nuts or weldments.

### STANDARD BOLT TORQUE CHART

Thread Size	SAE Grade 5 Torque ft lb (Nm)	SAE Grade 8 Torque ft lb (Nm)
0.25 in	7-10 (9-14)	10-13 (14-38)
0.31 in	15-20 (20-27)	20-26 (27-35)
0.38 in	27-35 (37-47)	36-47 (49-64)
0.44 in	43-56 (58-76)	53-76 (72-103)
0.50 in	65-85 (88-115)	89-116 (121-157)
0.62 in	130-170 (176-231)	117-265 (159-359)
0.75 in	215-280 (291-380)	313-407 (424-552)
1.00 in	500-650 (678-881)	757-984 (1026-1334)

*NOTE: Decrease torque by 20% when using a thread lubricant.*

### METRIC BOLT TORQUE CHART





Thread Size	Class 8.8 Torque ft lb (Nm)	Class 10.9 Torque ft lb (Nm)
M4	2 (3)	3 (4)
M5	4 (5)	6 (8)
M6	7 (9)	10 (14)
M8	18 (24)	25 (34)
M10	32 (43)	47 (64)
M12	58 (79)	83 (112)
M14	94 (127)	133 (180)
M16	144 (195)	196 (265)
M20	260 (352)	336 (455)
M24	470 (637)	664 (900)

*NOTE: Decrease torque by 20% when using a thread lubricant.*

Exceptions to the above chart:

Check the machine for exceptions!

### BOLT IDENTIFICATION

Identification Grade Marking	Specification and Grade
	SAE-Grade 5
	SAE-Grade 8
	ISO-Grade 8.8
	ISO-Grade 10.9

01395

### THREAD SEALANT AND LOCKING COMPOUNDS

Thread sealants and locking compounds may be used on this machine. They include the following:

Loctite 515 sealant - gasket forming material. TENNANT Part No. 75567, 15 oz (440 ml) cartridge.

Loctite 242 blue - medium strength thread locking compound. TENNANT Part No. 32676, 0.5 ml tube.

Loctite 271 red - high strength thread locking compound. TENNANT Part No. 19857, 0.5 ml tube.

**HYDRAULIC FITTING INFORMATION**

**HYDRAULIC TAPERED PIPE FITTING (NPT)  
TORQUE CHART**

*NOTE: Ratings listed are when using teflon thread seal.*

Size	Minimum Torque	Maximum Torque
1/4 NPT	10 ft lb (14 Nm)	30 ft lb (41 Nm)
1/2 NPT	25 ft lb (34 Nm)	50 ft lb (68 Nm)
3/4 NPT	50 ft lb (68 Nm)	100 ft lb (136 Nm)

**HYDRAULIC TAPERED SEAT FITTING (JIC)  
TORQUE CHART**

Tube O.D. (in)	Thread Size	Maximum Torque
0.25	0.44-20	9 ft lb (12 Nm)
0.38	0.56-18	20 ft lb (27 Nm)
0.50	0.75-16	30 ft lb (41 Nm)
0.62	0.88-14	40 ft lb (54 Nm)
0.75	1.12-12	70 ft lb (95 Nm)
1.0	1.31-12	90 ft lb (122 Nm)

**HYDRAULIC O-RING FITTING TORQUE  
CHART**

Tube O.D. (in)	Thread Size	Minimum Torque	Maximum Torque
0.25	0.44-20	6 ft lb (8 Nm)	9 ft lb (12 Nm)
0.38	0.56-18	13 ft lb (18 Nm)	20 ft lb (27 Nm)
		*10 ft lb (14 Nm)	12 ft lb (16 Nm)
0.50	0.75-16	20 ft lb (27 Nm)	30 ft lb (41 Nm)
		*21 ft lb (28 Nm)	24 ft lb (33 Nm)
0.62	0.88-14	25 ft lb (34 Nm)	40 ft lb (54 Nm)
0.75	1.12-12	45 ft lb (61 Nm)	70 ft lb (95 Nm)
1.0	1.31-12	60 ft lb (81 Nm)	90 ft lb (122 Nm)

*NOTE: Do not use sealant on o-ring threads.*

\*Aluminum bodied components





**CONTENTS**

	Page
INTRODUCTION .....	2-3
BRAKES AND TIRES .....	2-4
SERVICE BRAKES .....	2-4
TO REPLACE BRAKE SHOES .....	2-4
PARKING BRAKE .....	2-7
TO ADJUST BRAKES .....	2-8
FRONT TIRES AND WHEELS .....	2-11
TO REPLACE FRONT WHEEL BEARINGS .....	2-11
REAR TIRE AND WHEEL, AND WHEEL SUPPORT .....	2-14
TO REPLACE REAR WHEEL HOUSING PIVOT BEARINGS ...	2-14



**INTRODUCTION**

This section includes information on the main chassis related components for example the brakes, wheel support, and tires.

## BRAKES AND TIRES

---

### SERVICE BRAKES

The mechanical service brakes are located on the front wheels. The brakes are operated by the foot brake pedal and connecting rods.

Check the brake adjustment every 200 hours of operation. The brake pedal should not travel more than 25 mm (1 in) to fully engage the brakes.

### TO REPLACE BRAKE SHOES

**FOR SAFETY: Before Leaving Or Servicing Machine; Stop On Level Surface, Set Parking Brake, Turn Off Machine And Remove Key.**

1. Disengage the parking brake if activated.

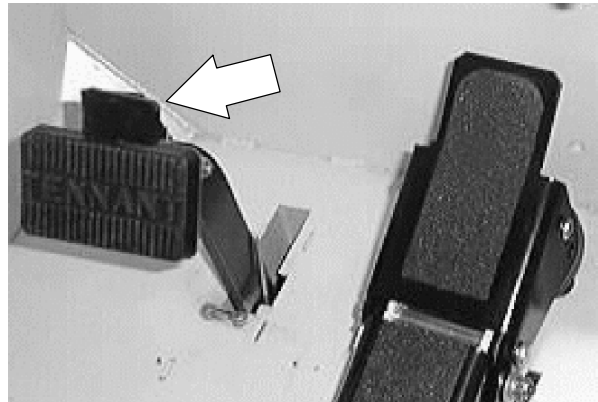

2. Jack up one front corner of the machine. Place jack stands under machine frame.

**FOR SAFETY: Block machine tires before jacking machine up. Jack machine up at designated locations only. Block machine up with jack stands.**

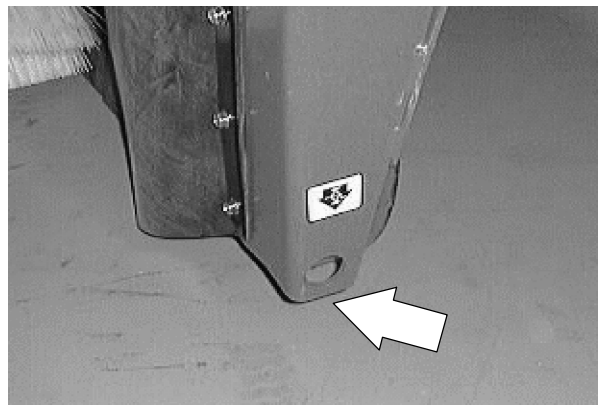

3. Remove the hub cap in the center of front wheel.

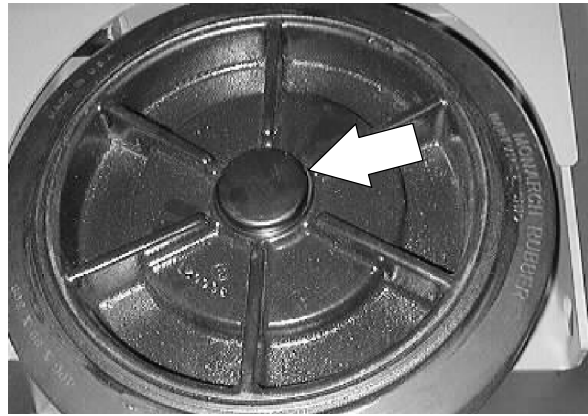

4. Remove the cotter pin, slotted nut, and flat washer.

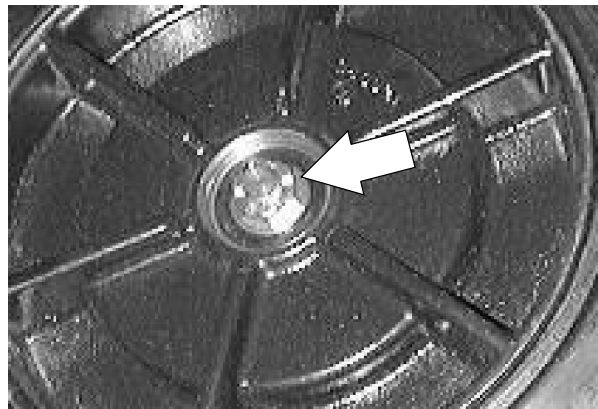

5. Slide the wheel off the axle.

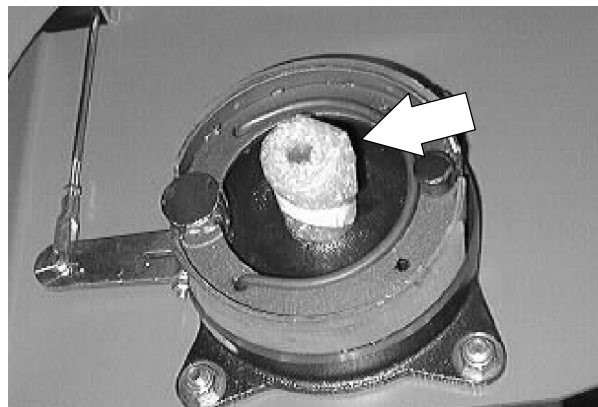

6. Remove the one large "C" shaped tension spring holding the old brake shoes together. Remove the old brake shoes.

7. Replace the old brake shoes with new brake shoes.



## CHASSIS

8. Reinstall the one large "C" shaped brake tension spring on the new brake shoes.

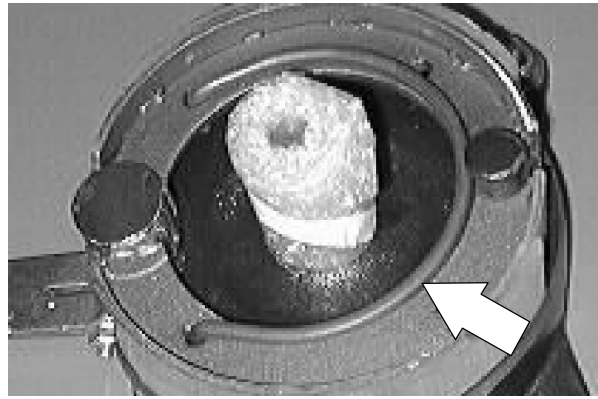

9. Slide the wheel back on the axle.

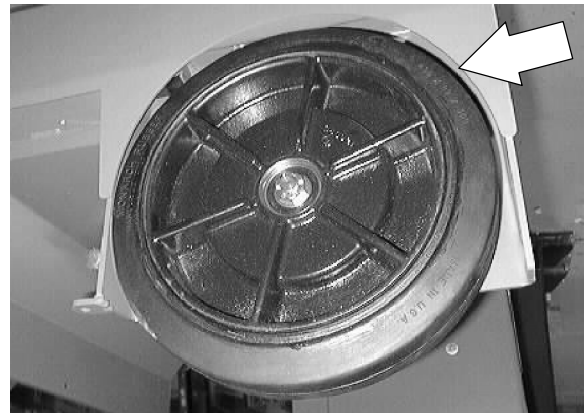

10. Reinstall the flat washer and nut on the axle shaft.

11. Tighten the nut with a hand wrench until the wheel binds, then back the nut off to nearest cotter pin hole.

12. Insert a new cotter pin through nut and hole.

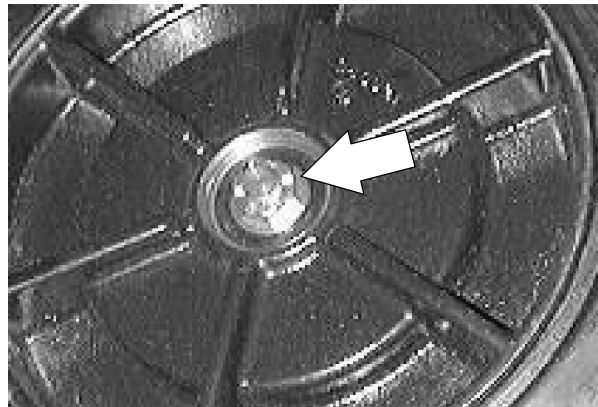

13. After making sure the wheel spins freely, carefully reinstall the hub cap.

14. Repeat the procedure on the other wheel.

15. Remove the jackstands and lower the machine.

16. Drive the machine and operate the brakes. Check for proper operation.

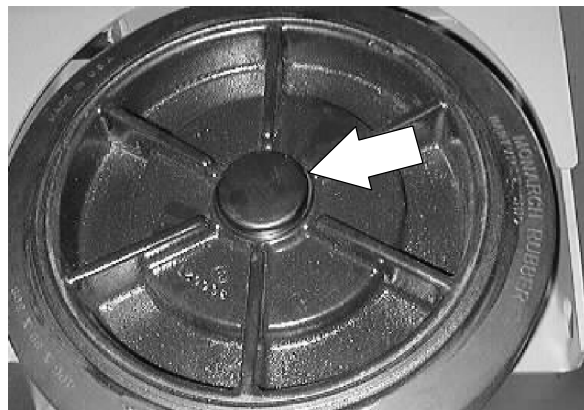

**PARKING BRAKE**

The parking brake is set with the parking brake lever that activates the service brakes.

Adjust the parking brake whenever it becomes very easy to set, when the machine rolls after setting the parking brake, and after every 200 hours of operation. The parking brake may be tightened by adjusting the brake rod clevis on the ends of the brake cross shaft. See TO ADJUST BRAKES instructions. Adjust the parking brake so it will hold the machine on a smooth 8 degree incline. The brake pedal should not travel more than 25 mm (1 in) to fully engage the brakes.

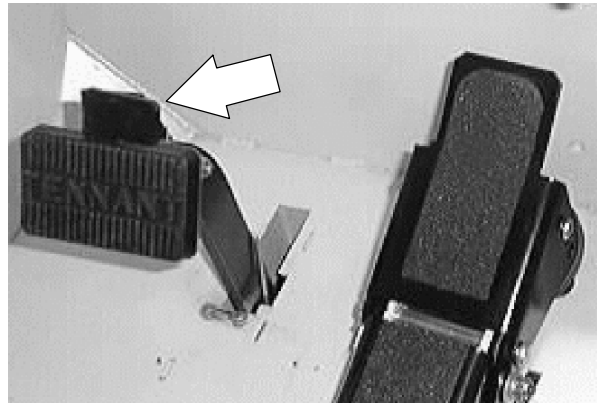

## CHASSIS

### TO ADJUST BRAKES

**FOR SAFETY: Before Leaving Or Servicing Machine; Stop On Level Surface, Set Parking Brake, Turn Off Machine And Remove Key.**

1. Raise the hopper and engage the support bar. Open the engine side door.

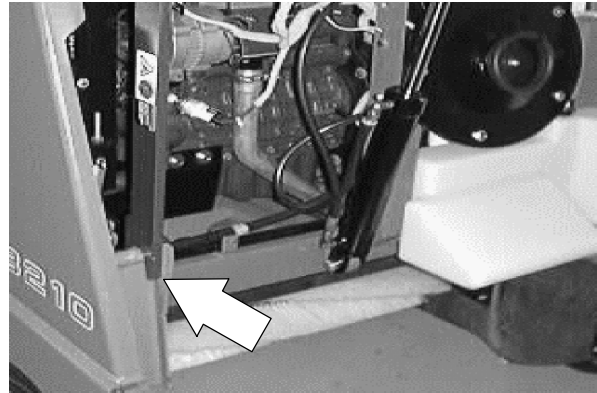

2. Disengage the parking brake if activated.

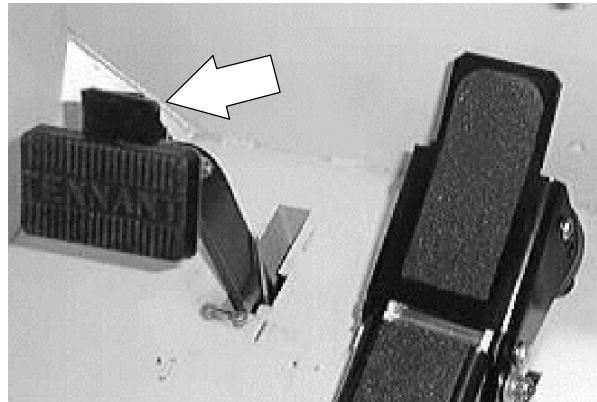

3. Jack up one front corner of the machine. Place jack stands under machine frame.

**FOR SAFETY: Block machine tires before jacking machine up. Jack machine up at designated locations only. Block machine up with jack stands.**

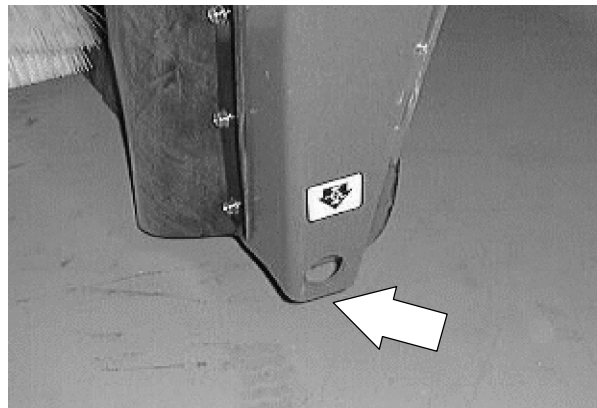



4. Locate the right side brake rod clevis near the front, lower corner of the engine radiator and the left side brake rod clevis below the detergent tank in the engine compartment.

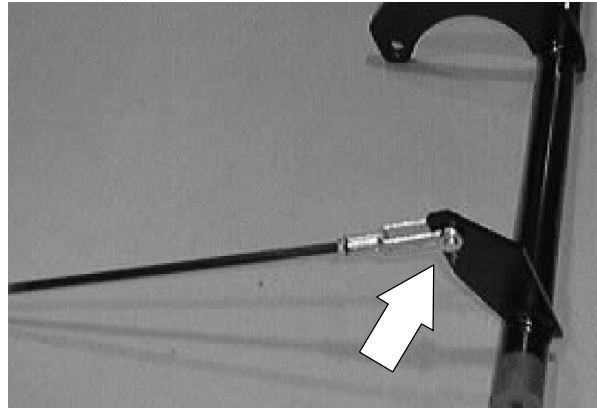

5. Remove the cotter pin and the clevis pin holding the brake rod clevis to the brake assembly lever.

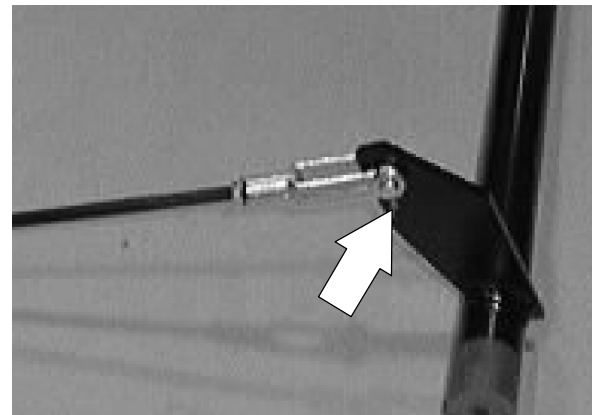

6. Loosen the jam nut on the brake rod.

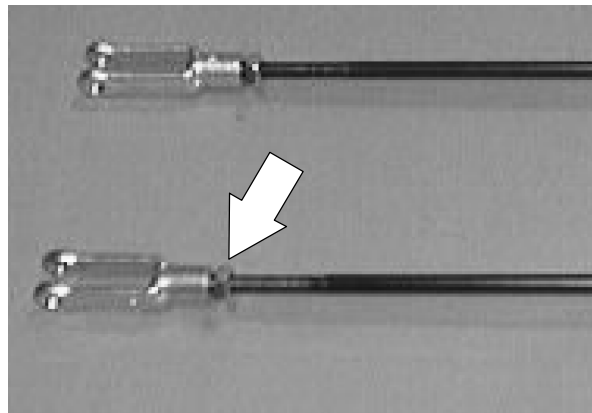

7. Turn the clevis in or out to achieve proper adjustment and pedal travel. The pedal should move approximately 1" before engaging the brakes.

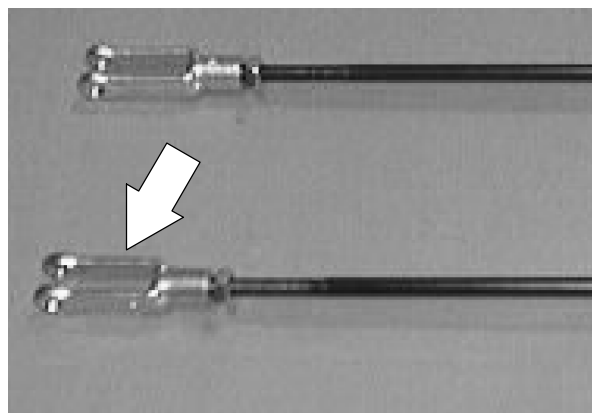

## CHASSIS

8. Reinstall the cotter pin and the clevis pin in the brake rod clevis and the brake assembly lever.

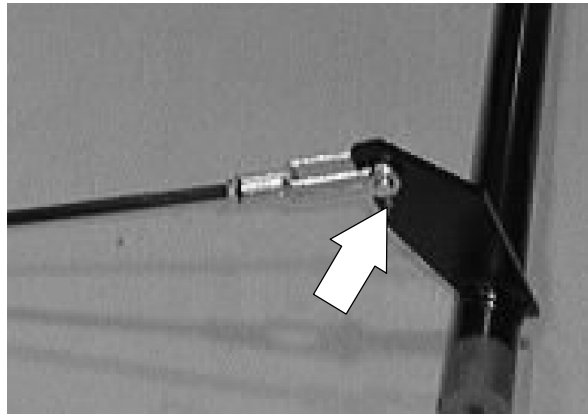

9. Repeat the procedure on both sides.

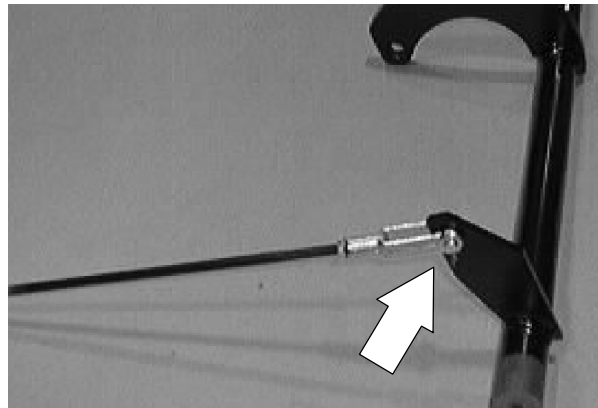

10. Close the engine side door. Disengage the support bar and lower the hopper.

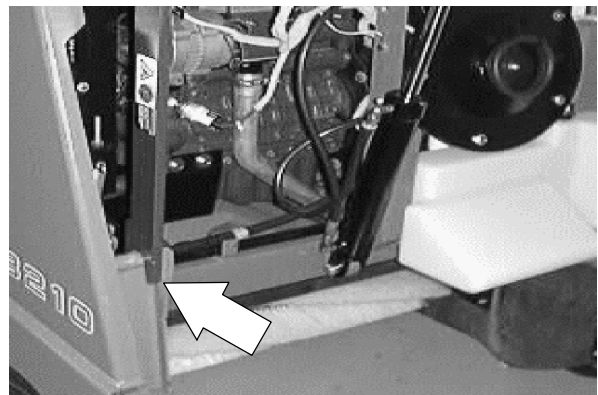

11. Drive the machine and operate the brakes. Check for equal engagement of the brakes on both wheels.

---

**FRONT TIRES AND WHEELS**

---

The machine front tires are solid. Inspect the front wheel bearings for seal damage.

**TO REPLACE FRONT WHEEL BEARINGS**

**FOR SAFETY: Before Leaving Or Servicing Machine; Stop On Level Surface, Set Parking Brake, Turn Off Machine And Remove Key.**

1. Disengage the parking brake if activated.

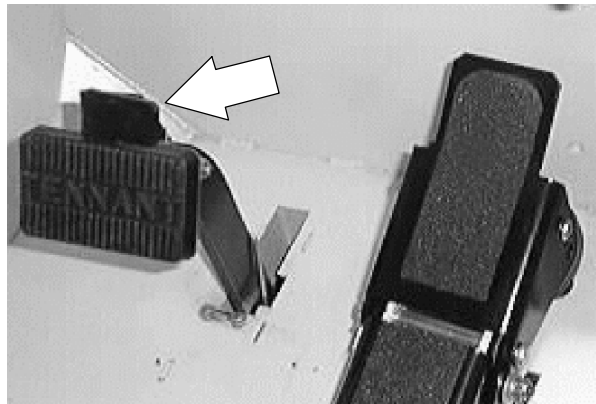

2. Jack up one front corner of the machine. Place jack stands under machine frame.

**FOR SAFETY: Block machine tires before jacking machine up. Jack machine up at designated locations only. Block machine up with jack stands.**

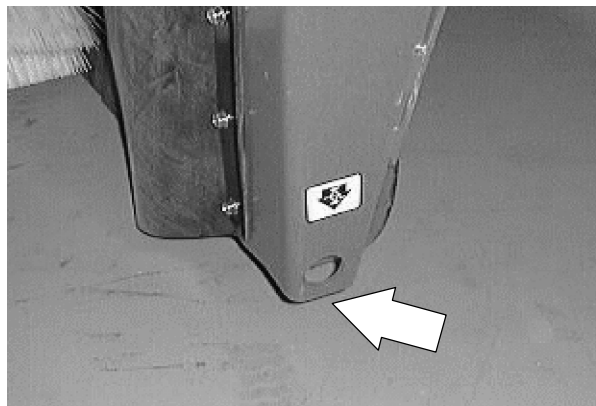

## CHASSIS

3. Remove the hub cap in the center of front wheel.

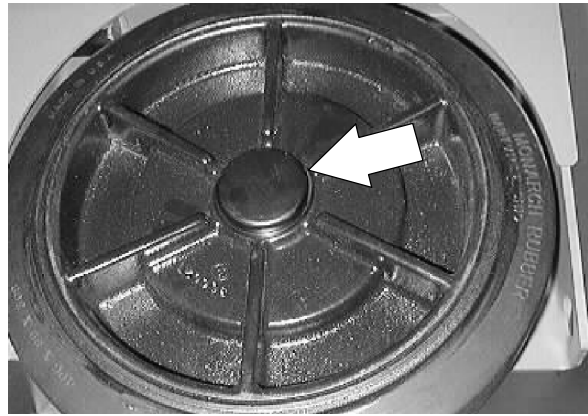

4. Remove the cotter pin, slotted nut, and flat washer.

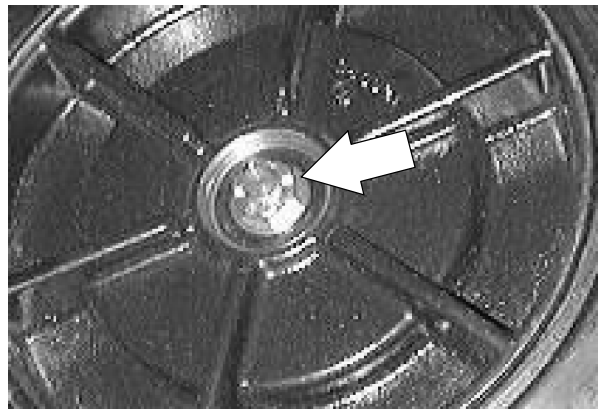

5. Slide the wheel off the axle.

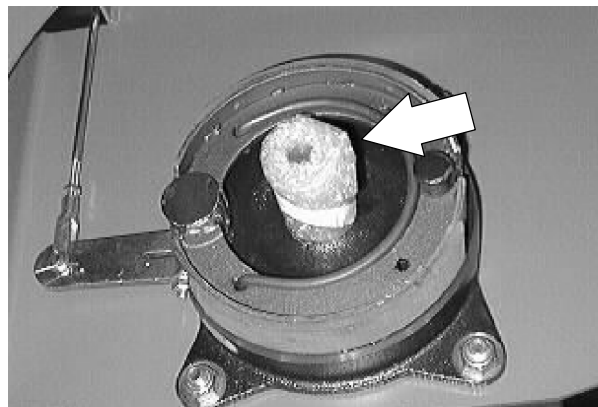

6. Press the old bearings out. Press the new bearings in the wheel in the same orientation.

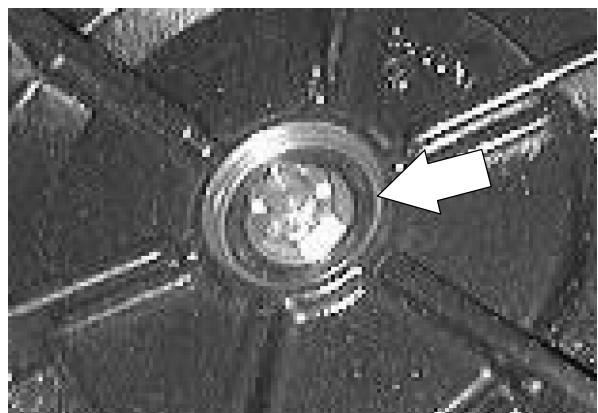

7. Slide the wheel back on the axle.

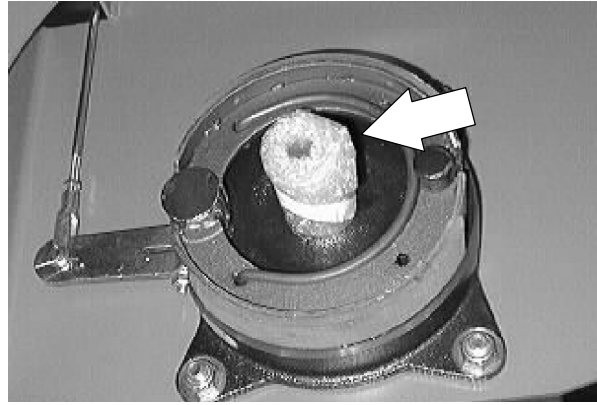

8. Slide the flat washer and nut on the shaft.

9. Tighten the nut with a hand wrench until the wheel binds, then back the nut off to nearest cotter pin hole.

10. Insert a new cotter pin through nut and hole.

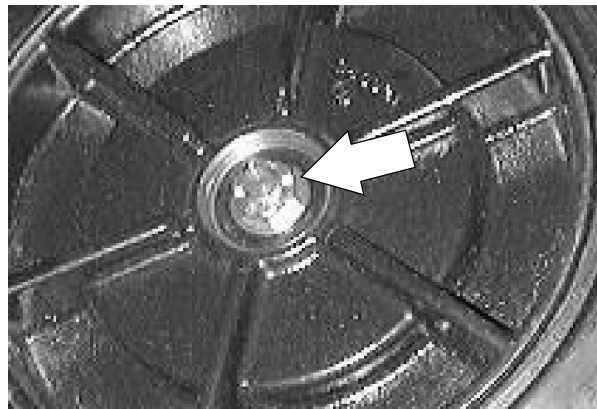

11. After making sure the wheel spins freely, carefully reinstall the hub cap.

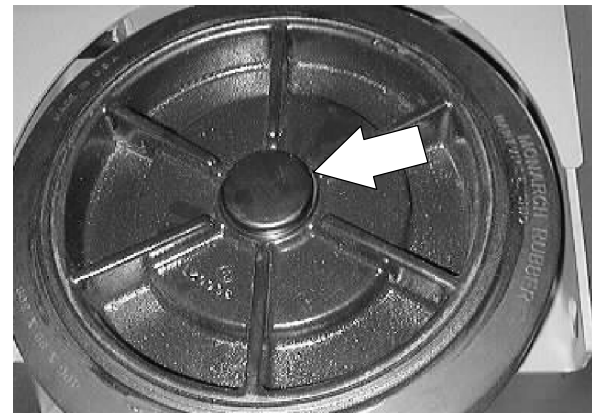

12. Remove the jackstands and lower the machine.

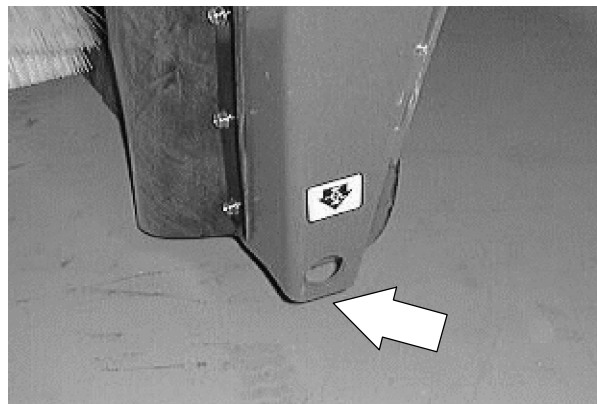

13. Repeat the procedure on the other wheel.

## CHASSIS

### REAR TIRE AND WHEEL, AND WHEEL SUPPORT

The standard rear machine tire is solid. The rear wheel support pivots the rear drive wheel. It consists of the rear tire and drive motor. The support has two grease fittings for the bearings. The rear wheel support bearings must be lubricated every 200 hours of operation. Use Lubriplate EMB grease (TENNANT part no. 01433-1).

Torque the rear wheel nuts twice in the pattern shown to 122 to 150 Nm (90 to 110 ft lb) after the first 50-hours of operation, and every 800 hours there after.

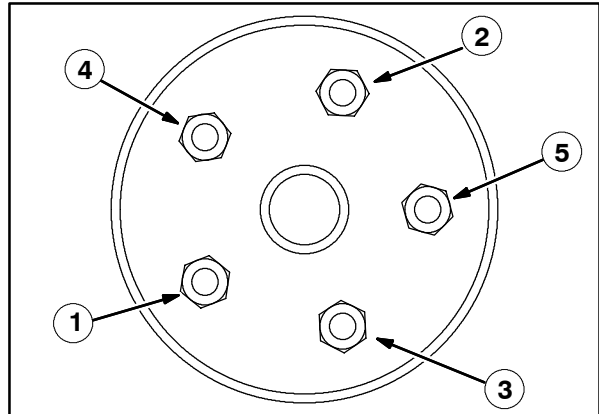

### TO REPLACE REAR WHEEL HOUSING PIVOT BEARINGS

**FOR SAFETY: Before Leaving Or Servicing Machine; Stop On Level Surface, Set Parking Brake, Turn Off Machine And Remove Key.**

1. Engage parking brake, block front tires.

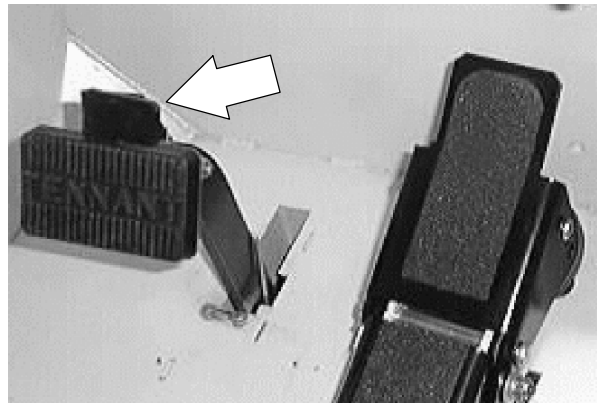

2. Jack up rear of machine. Use jack stands to support machine.

**FOR SAFETY: Block machine tires before jacking machine up. Jack machine up at designated locations only. Block machine up with jack stands.**



3. Remove the rear tire and wheel assembly from the drive motor hub.

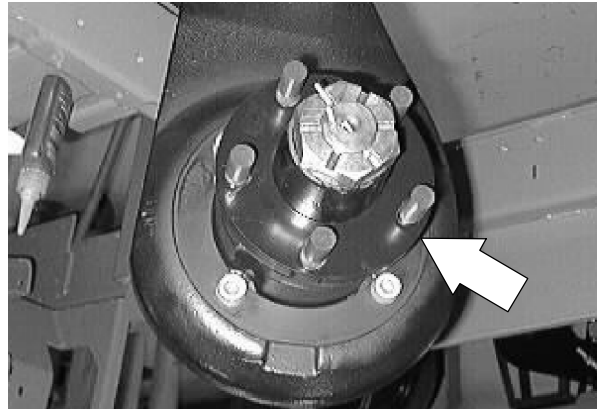

4. Remove the cotter pin and slotted nut from drive motor shaft and hub.



5. Use a puller to remove the drive hub from the tapered motor shaft.

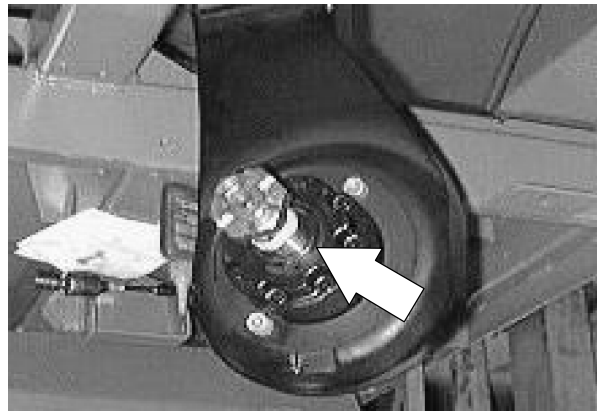

6. Mark, disconnect, and plug the hydraulic hoses leading to the the drive motor.

*NOTE: Observe hydraulic cleanliness requirements when opening hydraulic lines.*

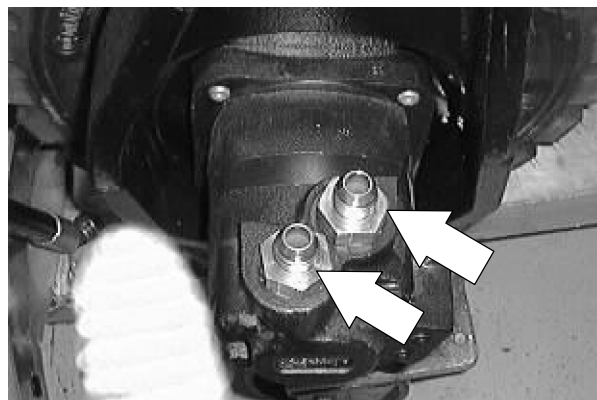

## CHASSIS

7. Remove the rear drive motor mounting bolts.

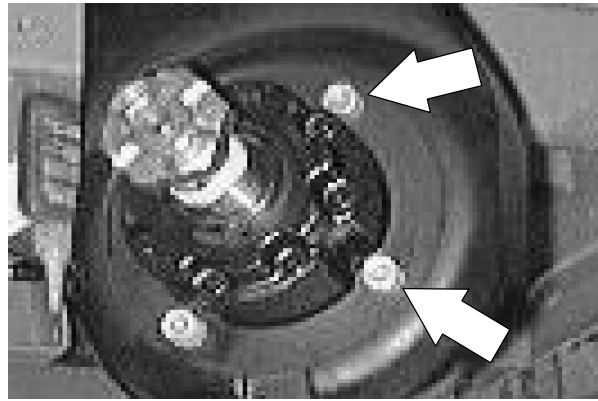

8. Slide the rear drive motor out of the wheel housing.



9. Remove the hydraulic hose clamp from the wheel housing.

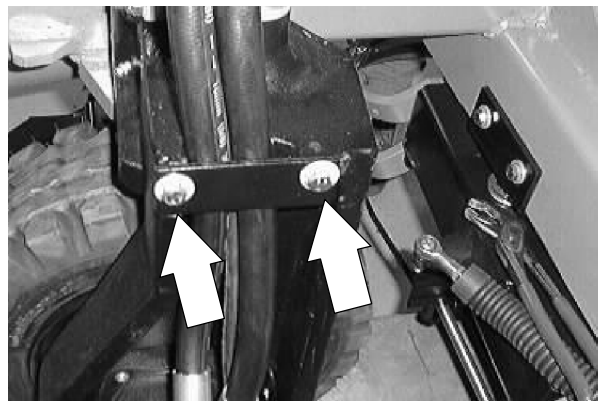

10. Remove the hex screw and nyloc nut attaching the rod end of steering cylinder to rear wheel housing.

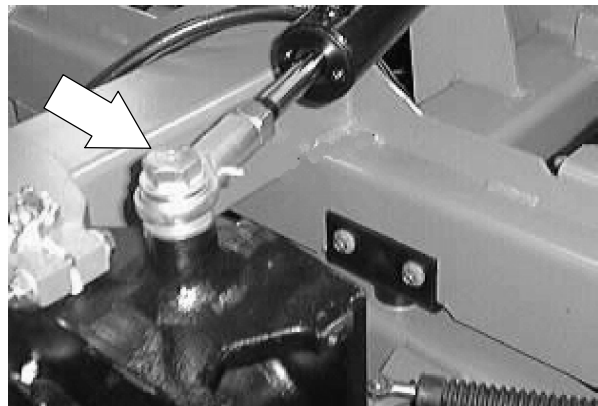



11. Loosen the two hex screws holding the drive casting pivot pin in the frame.

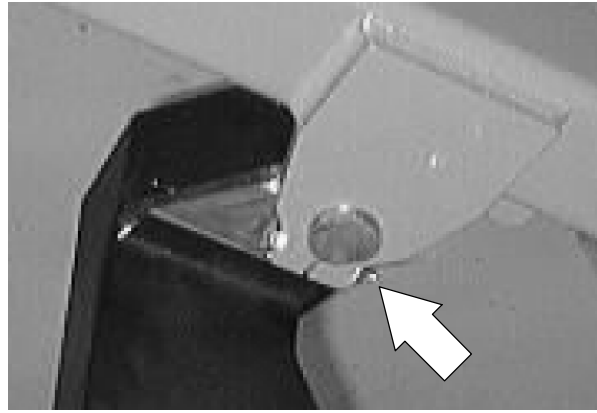

12. Remove the cotter pin from the large slotted nut on top of the rear casting pivot pin. Remove the slotted nut.



13. Drop the pivot pin down and out of the machine.

14. Slide the wheel housing out of the main frame.

*NOTE: Make sure to retain the thrust washer and felt washer from between the top of the drive casting and machine frame.*

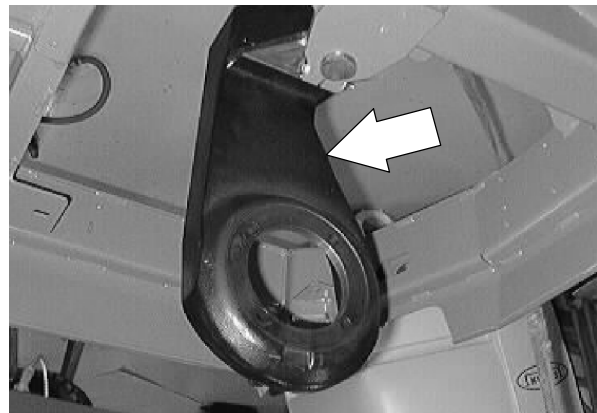

15. Remove the two bearing cones from the drive casting.



## CHASSIS

16. Remove and replace the pressed in bearing cups in the drive casting.

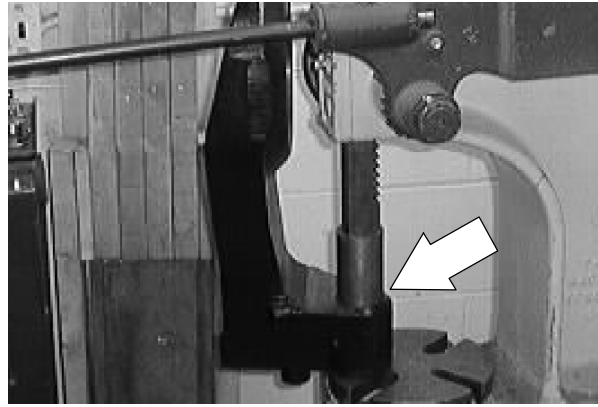

17. Pack the new bearing cones with Lubriplate EMB grease. Coat the bearing cups with grease.



18. Position the new bearings in the housing.

*NOTE: Make sure the bearing grease tube is installed in the casting before installing the bearings.*

19. Position the thrust washer and felt washer on top of the drive casting.

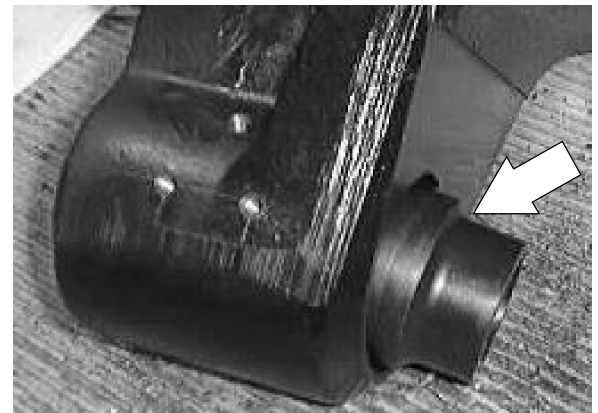

20. Slide the wheel housing in position in main frame.



21. Slide the pivot pin up through the frame hole. Thread castle nut on the pin. Tighten to 34 - 40 Nm (25 - 30 ft lb). Check for any play. If the pin is not seated, tap with rubber mallet and re-torque castle nut.

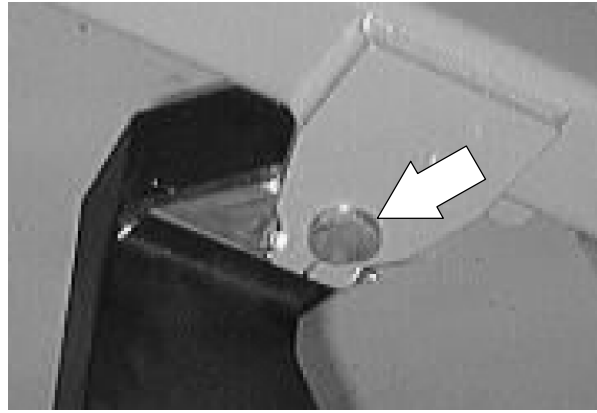

22. Torque the two hex screws to 37 - 48 Nm (26 - 34 ft lb).



23. Tighten the castle nut to next slot and insert the cotter pin. Torque not to exceed 100 Nm (75 ft lb).



24. Re-connect the rod end of the steering cylinder to the wheel housing using the .750x3.25 hex screw, nyloc nut, and flat washers. Tighten to 270 - 300 Nm (200 - 220 ft lb).



## CHASSIS

25. Slide the drive motor in the wheel housing.  
*Note the motor orientation.*

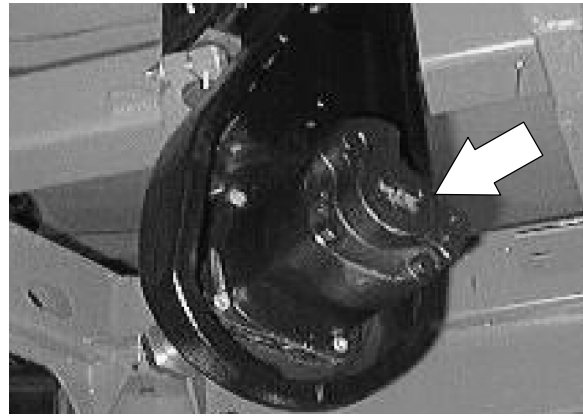

26. Thread the four hex screws through the wheel housing and into the motor. Tighten to 88-115 Nm (65-85 ft lb).

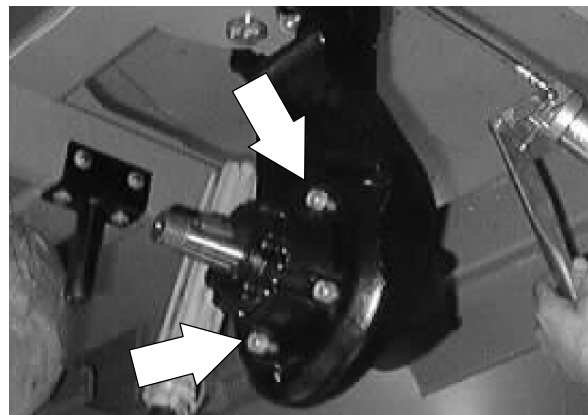

27. Reconnect the hydraulic hoses. See schematic in the HYDRAULICS section.

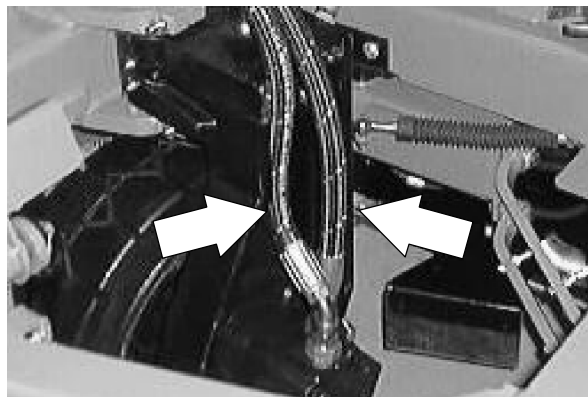

28. Reinstall the hose clamp to the wheel housing. Tighten the hex screws to 18.5 - 24Nm (15 - 20 ft lb).

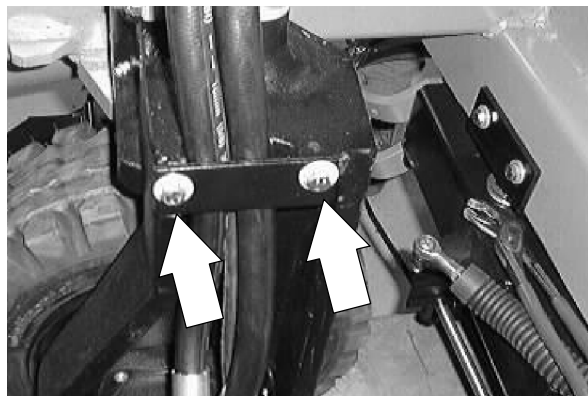

29. Mount the hub to the tapered motor shaft. Tighten the slotted nut to (275 ft lb). Torque to the next slot in nut. DO NOT back nut off to install cotter pin. *Install the cotter pin.*

*NOTE: Make sure the key is installed on the tapered shaft of the drive motor and a small amount of grease is placed on the shaft.*

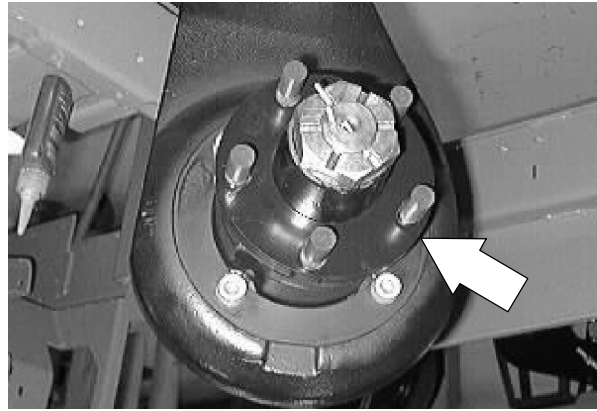

30. Install the rear tire and wheel assembly. Torque the rear wheel nuts to 100 - 120 Nm (85 - 95 ft lb).

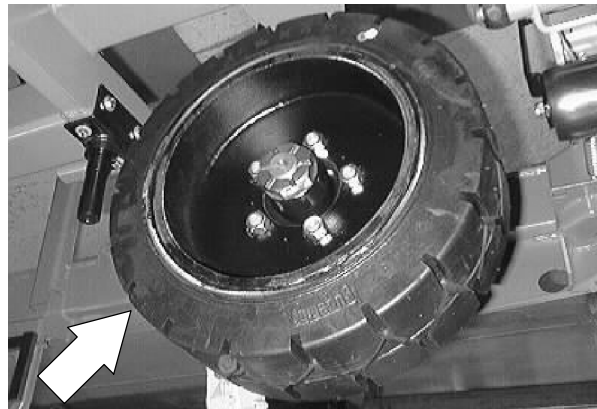

31. Start the engine. Run the propelling in both directions. Check for any leaks.

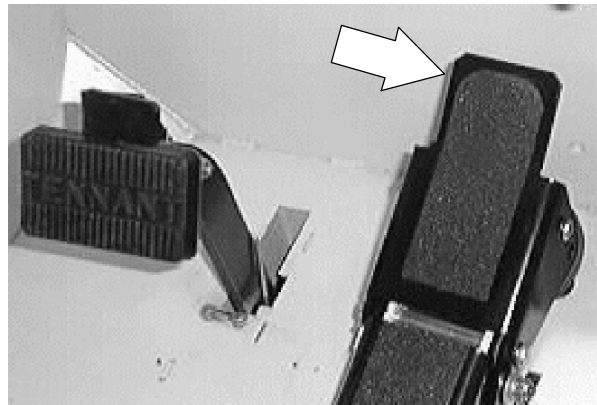

32. Remove the jack stands and lower the machine to the ground.





**CONTENTS**

	Page		Page
INTRODUCTION .....	3-3	SKIRTS AND SEALS .....	3-46
DEBRIS HOPPER .....	3-4	HOPPER LIP SKIRT .....	3-46
TO REMOVE HOPPER .....	3-4	TO REPLACE HOPPER LIP SKIRT ..	3-46
TO INSTALL HOPPER .....	3-7	BRUSH DOOR SKIRTS .....	3-49
TO ADJUST HOPPER LIP HEIGHT .	3-10	TO REPLACE AND ADJUST RIGHT	
TO ADJUST HOPPER BUMPER ....	3-11	HAND BRUSH DOOR SKIRT ....	3-49
HOPPER LIFT ARM .....	3-12	TO REPLACE AND ADJUST LEFT	
TO REMOVE HOPPER LIFT ARM ..	3-12	HAND BRUSH DOOR SKIRT ....	3-53
TO INSTALL HOPPER LIFT ARM ...	3-14	REAR SKIRT AND DEFLECTOR BLADE	3-56
HOPPER LIFT ARM ADJUSTMENT		TO REPLACE AND ADJUST THE	
BOLTS .....	3-15	REAR SKIRT AND DEFLECTOR	
HOPPER DUMP DOOR .....	3-16	BLADE .....	3-56
TO REMOVE HOPPER DUMP DOOR	3-16	HOPPER SEALS .....	3-60
TO INSTALL HOPPER DUMP DOOR	3-18	TO REPLACE HOPPER SEALS ....	3-60
HOPPER DUST FILTER .....	3-19	HOPPER DUST SEAL .....	3-62
TO REPLACE HOPPER DUST		HOPPER VACUUM FAN SEAL .....	3-62
FILTER .....	3-20	HOPPER DUMP DOOR SEALS .....	3-62
TO REMOVE FILTER SHAKER		TO REPLACE HOPPER DUMP	
ASSEMBLY .....	3-21	DOOR SEALS .....	3-63
TO INSTALL FILTER SHAKER		SWEEPING VACUUM FAN .....	3-65
ASSEMBLY .....	3-22	TO REMOVE SWEEPING VACUUM	
MAIN BRUSH .....	3-23	FAN ASSEMBLY .....	3-65
TO REPLACE MAIN BRUSH .....	3-23	TO INSTALL SWEEPING VACUUM	
TO CHECK AND ADJUST MAIN		FAN ASSEMBLY .....	3-68
BRUSH PATTERN .....	3-27	MACHINE TROUBLESHOOTING .....	3-71
TO REPLACE MAIN BRUSH IDLER			
PLUG BEARING .....	3-29		
TO REPLACE MAIN BRUSH SHAFT			
BEARINGS .....	3-34		
SIDE BRUSH .....	3-37		
TO REPLACE SIDE BRUSH .....	3-37		
TO ADJUST SIDE BRUSH PATTERN	3-40		
TO ADJUST SIDE BRUSH LATERAL			
TILT PATTERN .....	3-41		
TO ADJUST SIDE BRUSH FORE/AFT			
TILT PATTERN .....	3-43		
SIDE BRUSH GUARD .....	3-45		
TO ROTATE OR REPLACE SIDE			
BRUSH GUARD .....	3-45		





**INTRODUCTION**

The side brush sweeps debris into the path of the main brush. The main brush sweeps debris from the floor into the hopper. The vacuum system pulls dust and air through the hopper and the hopper dust filter.

# SWEEPING

## DEBRIS HOPPER

The debris hopper collects the debris swept up by the machine. The hopper includes the following main components: hopper dust filter, Thermo Sentry, hopper dump door, and dust skirts. All adjustments have been made at the factory and require no regular maintenance. If hopper components are repaired or replaced, some components may need to be readjusted for best performance. The hopper may need to be removed from the machine for some repair or service work.

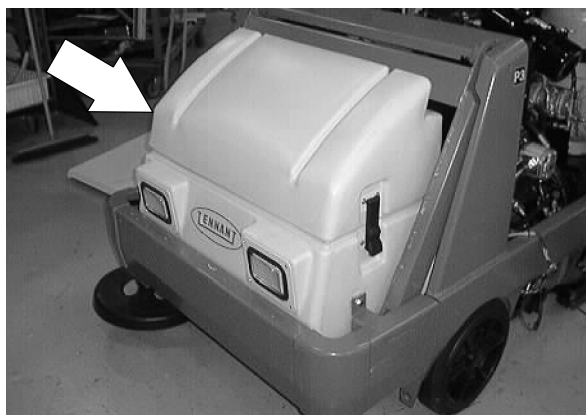

## TO REMOVE HOPPER

**FOR SAFETY: Before Leaving Or Servicing Machine; Stop On Level Surface, Set Parking Brake.**

1. Start the machine and raise the hopper and open the dump door. Engage the support bar.



2. Remove the hopper level adjustment bolt, nut, and washers.

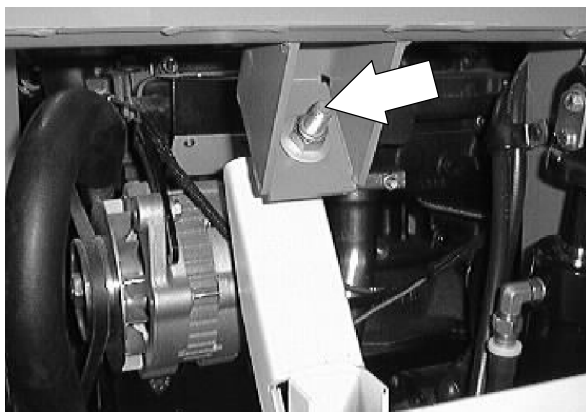

- Cut the plastic ties holding the hopper harness to the main harness.

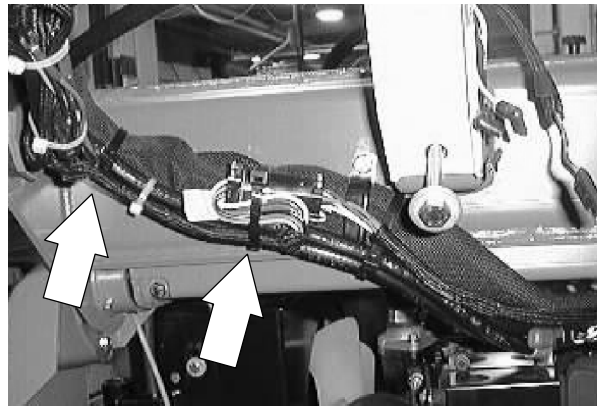

- Unplug the hopper harness connectors from the main harness.

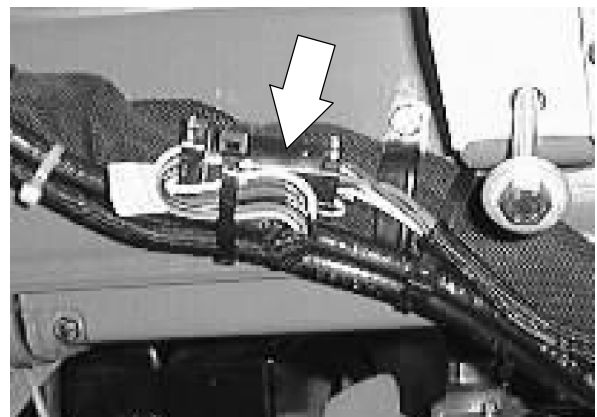

- Remove the two clevis pins holding the dump door cylinder to the back of the hopper. Let the cylinder drop out of the way.

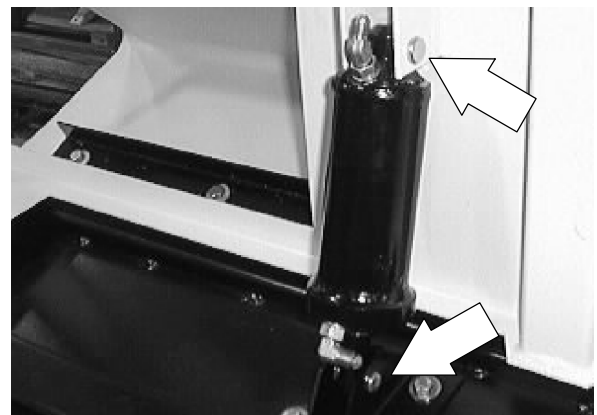

- Disengage the hopper support bar and lower the hopper. Place blocks under the hopper.

**FOR SAFETY: Before Leaving Or Servicing Machine; Stop On Level Surface, Set Parking Brake, Turn Off Machine And Remove Key.**

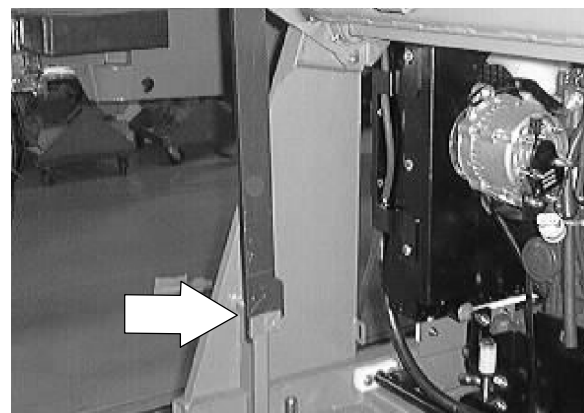

## SWEEPING

7. Disconnect and plug the hydraulic hoses leading to the side brush motor.

*NOTE: Observe hydraulic cleanliness requirements when opening hydraulic lines.*

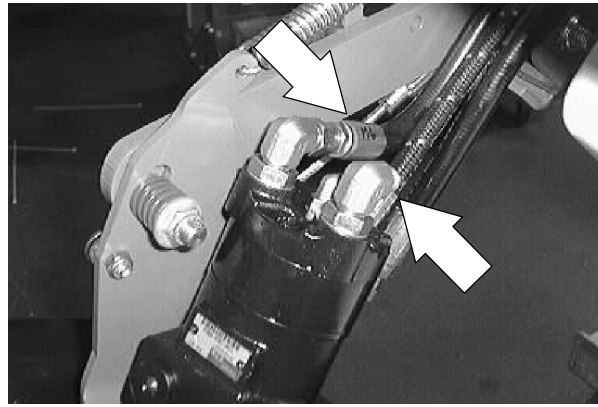

8. Disconnect the side brush lift cable at the hydraulic motor.

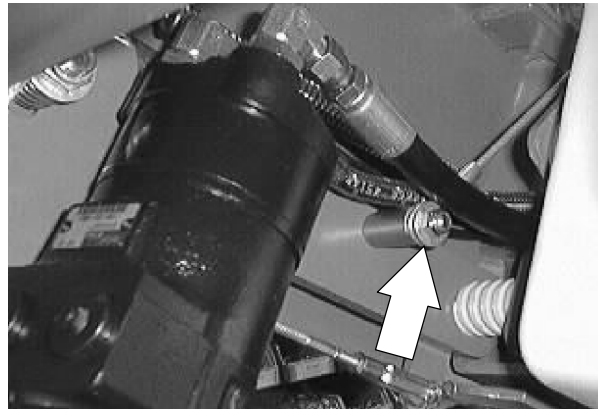

9. Remove the two hex screws holding the pivot pins to each side of the hopper lift arm.

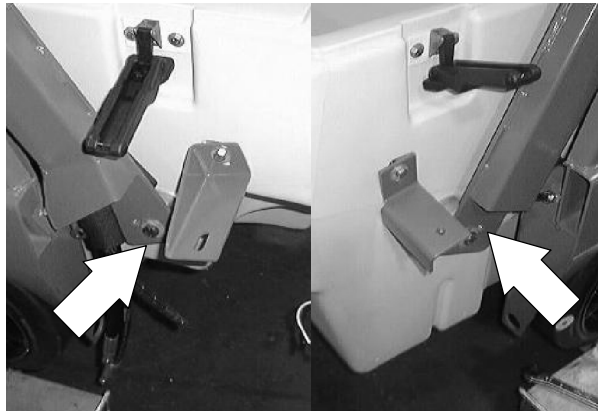

10. The hopper can now be removed from the machine. Remove and retain the hopper pivot pins from the molded pockets in the sides of the hopper.



**TO INSTALL HOPPER**

**FOR SAFETY: Before Leaving Or Servicing Machine; Stop On Level Surface, Set Parking Brake, Turn Off Machine And Remove Key.**

1. Position the hopper in front of machine. Make sure the hopper is sitting on two wood blocks.

*NOTE: Be careful not to pinch hydraulic hoses or electrical wires during this procedure.*

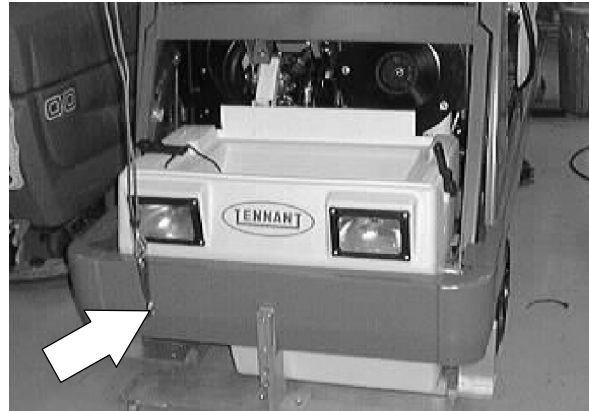

2. Reconnect the hydraulic hoses to the side brush motor. See the schematic in the HYDRAULICS section.

*NOTE: Observe hydraulic cleanliness requirements when opening hydraulic lines.*

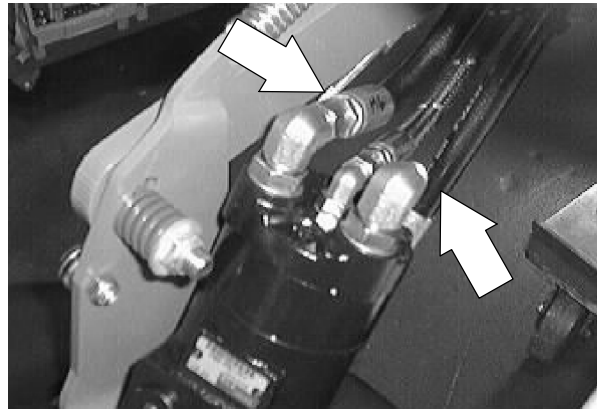

3. Position the two hopper pivot pins into the molded pockets in the sides of the hopper.

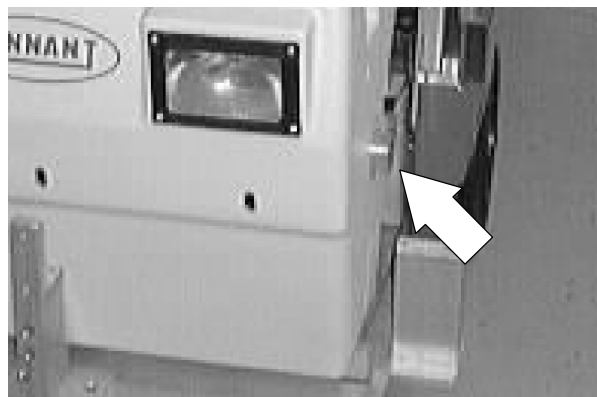

## SWEEPING

4. Line up the holes in the hopper pivot pins with the slots in the hopper lift arms. Install the two hex screws. Leave loose for now.

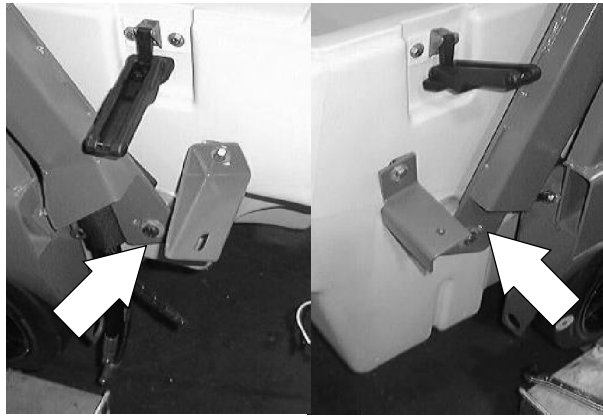

5. Reconnect the side brush lift cable at the side brush assembly.

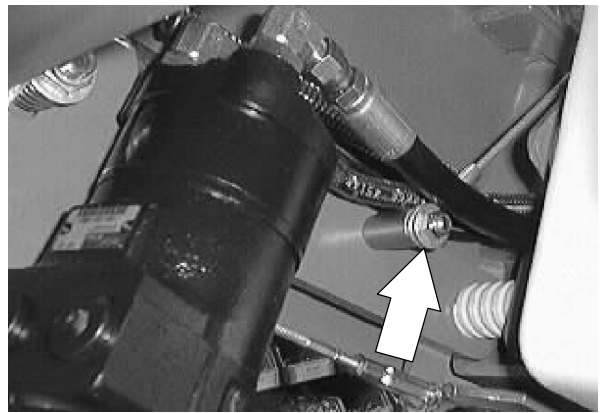

6. Reconnect the hopper harness to the main harness. See the schematic in the ELECTRICAL section.

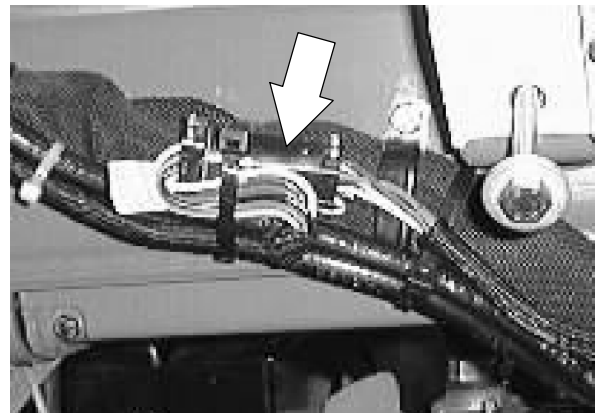

7. Reinstall the lip height adjustment bolt on the back of the hopper.

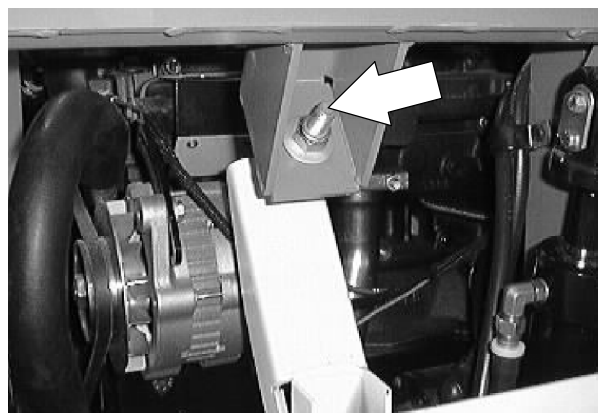

8. Push the hopper back and line up the hopper bumper with the machine frame bumper. Tighten the two hopper pivot pin hex screws to 64 - 83 Nm (47 - 61 ft lb).



9. Position the dump door lift cylinder onto the back of the hopper and dump door. Reinstall the two clevis pins and cotter pins.

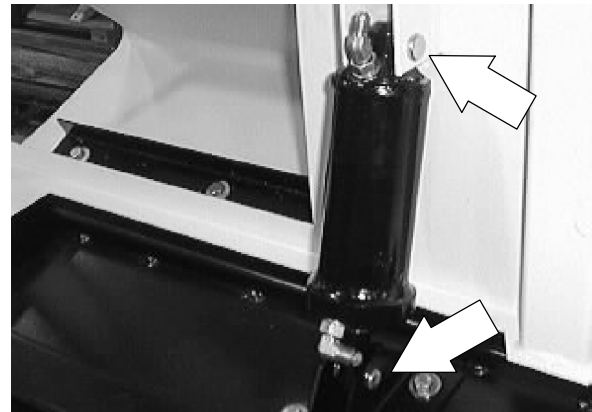

10. Start engine and check for proper operation of dump door, side brush rotation and side brush up and down.

## SWEEPING

### TO ADJUST HOPPER LIP HEIGHT

**FOR SAFETY: Before Leaving Or Servicing Machine; Stop On Level Surface, Set Parking Brake, Turn Off Machine And Remove Key.**

1. The hopper lip height adjustment should be 2.5 inches from the floor to the hopper bottom.



2. To achieve this measurement, adjust the length of the adjustment bolt on the back of the hopper.

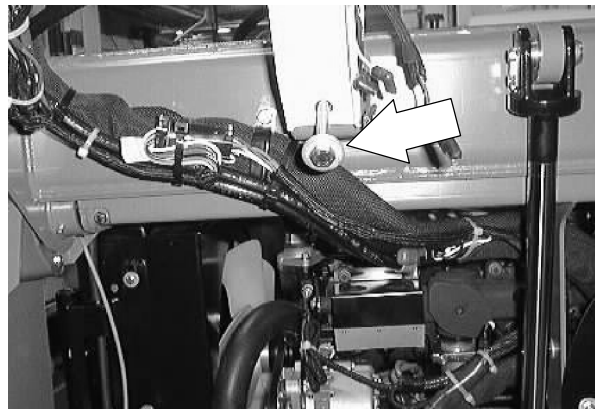



**TO ADJUST HOPPER BUMPER**

**FOR SAFETY: Before Leaving Or Servicing Machine; Stop On Level Surface, Set Parking Brake, Turn Off Machine And Remove Key.**

1. Loosen the four hex screws and nyloc nuts holding the hopper bumper to the sides of the hopper.



2. Loosen the three hex screws holding the hopper bumper to the front of the hopper.

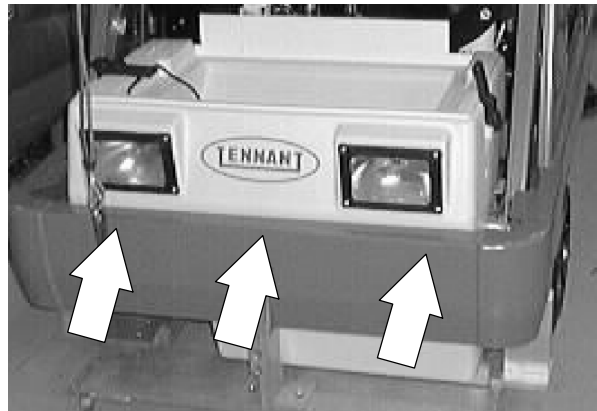

3. Adjust the hopper bumper so it is level with the machine frame.



4. Firmly tighten all of the hardware.

# SWEEPING

## HOPPER LIFT ARM

The hopper lift arm assembly and hopper lift cylinder raises and lowers the debris hopper. The lift arm is held in place by two pivot pins.

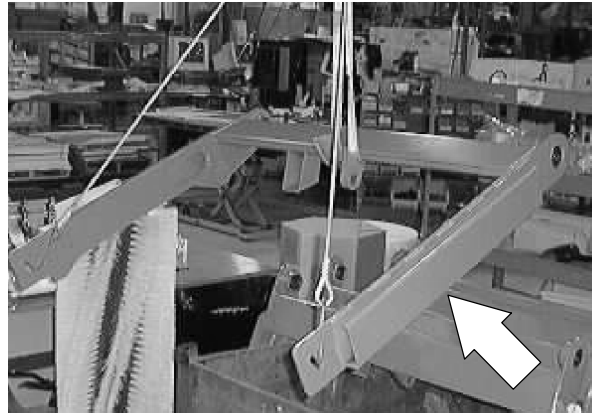

### TO REMOVE HOPPER LIFT ARM

**FOR SAFETY: Before Leaving Or Servicing Machine; Stop On Level Surface, Set Parking Brake, Turn Off Machine And Remove Key.**

1. Remove the debris hopper. See TO REMOVE HOPPER FROM MACHINE instructions.



2. Remove the upper, hopper lift cylinder pin.



3. Raise up slightly on the lift arm to take pressure off the cylinder pin. Remove the pin.



4. Remove the socket screws holding the hopper pivot pins to the frame towers.

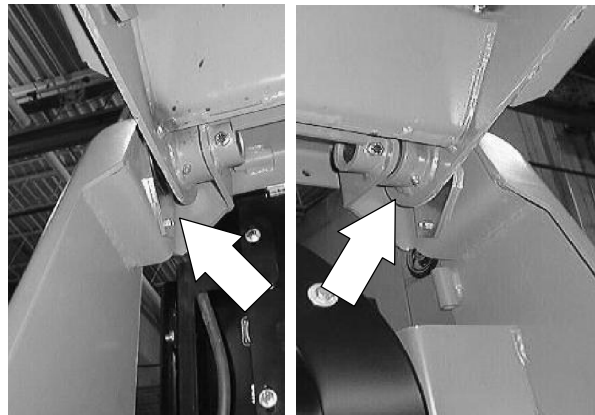

5. Raise up slightly on the lift arm to take pressure off the pins. Remove the pins and washers and remove the lift arm from the machine.



6. If the large self aligning bearing needs to be changed, remove retaining rings and press the old bearing out of the lift arm.

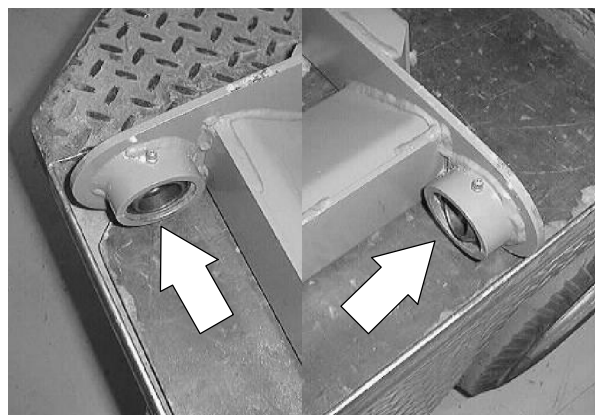

## SWEEPING

### TO INSTALL HOPPER LIFT ARM

**FOR SAFETY: Before Leaving Or Servicing Machine; Stop On Level Surface, Set Parking Brake, Turn Off Machine And Remove Key.**

1. Position lift arm in the machine, aligning the upper bearings in the lift arm with the holes in the towers of the machine.

*NOTE: Make sure the side brush lift cable is looped over the plastic pulley on the right hand lift arm pin.*



2. Install the lift arm pins in the bearings from the inside of the machine. Make sure to reinstall the spacer washers that were removed when the pins were removed.

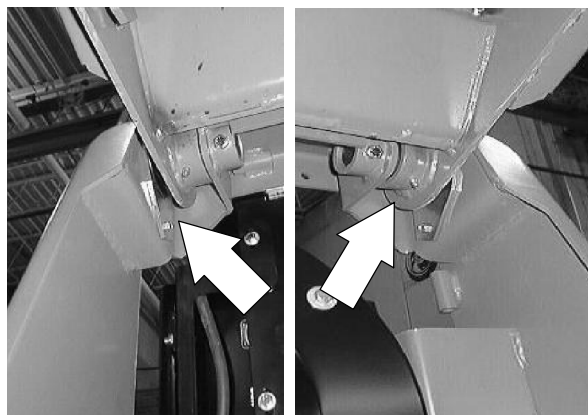

3. Align the hole in lift arm pin with the hole in the pin boss on the tower. Install the socket screws and tighten to 18 - 24 Nm (13 - 18 ft lb).

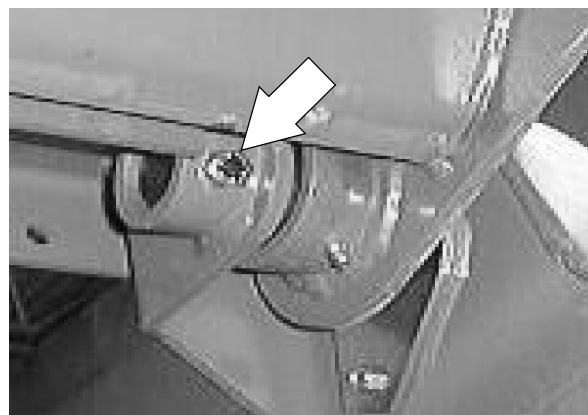

- Align the small fiberglide bearing in the lift arm cylinder lug with the hole in the clevis on the hopper lift cylinder. Reinstall the cylinder pin and cotter pins.

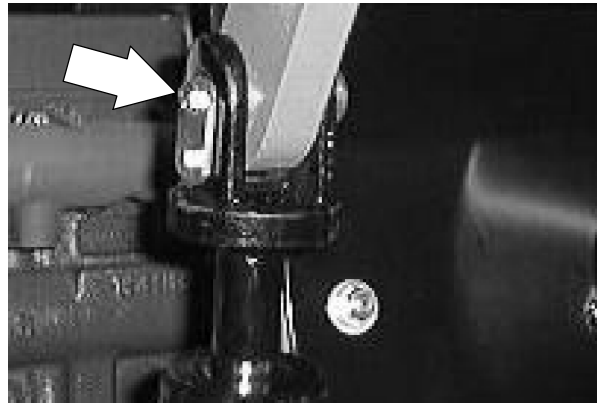

- Reinstall the hopper assembly. See TO INSTALL HOPPER instructions.



#### HOPPER LIFT ARM ADJUSTMENT BOLTS

**FOR SAFETY: Before Leaving Or Servicing Machine; Stop On Level Surface, Set Parking Brake, Turn Off Machine And Remove Key.**

- The lift arm adjustment bolts are used to position the lift arms correctly. The **left side** bolt should be *2.25 inch* from the top of the bolt head to the frame. The **right side** bolt should be *1.21 inch* from the top of the bolt head to the frame

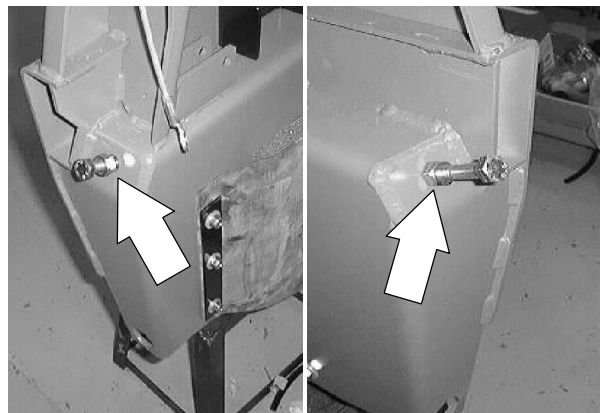

# SWEEPING

## HOPPER DUMP DOOR

The hopper dump door is used to control debris when dumping. It also seals the hopper to the main brush compartment. The dump door is open and closed with a hydraulic cylinder.

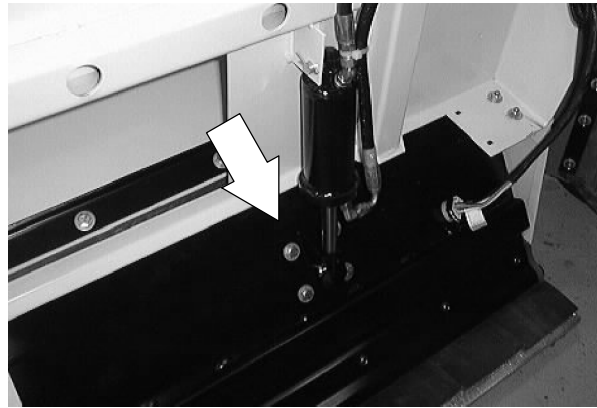

### TO REMOVE HOPPER DUMP DOOR

1. Make sure the hopper is emptied of all debris. Engage the parking brake.

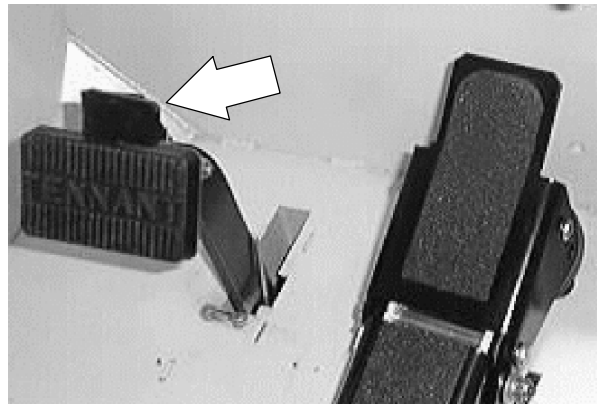

2. Raise the hopper and engage the prop rod.

 **WARNING: Raised Hopper May Fall. Engage Hopper Support Bar.**

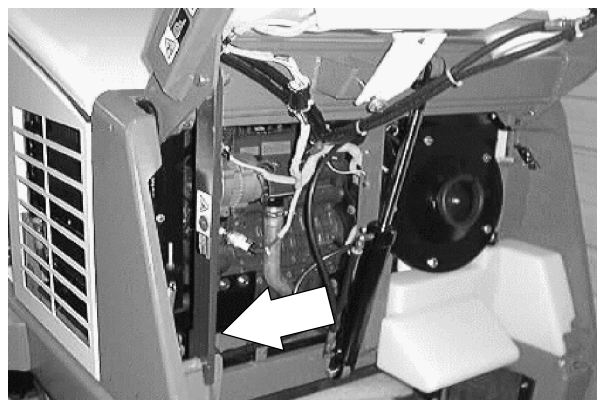

3. Open the dump door. Shut off the engine.

**FOR SAFETY: Before Leaving Or Servicing Machine; Stop On Level Surface, Set Parking Brake, Turn Off Machine And Remove Key.**

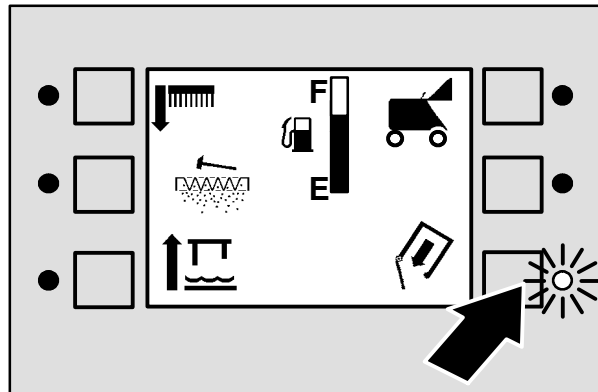

351659

4. Disconnect the rod end of dump door cylinder from the bracket on the center of the dump door.



5. Remove the hex screws holding the seal on the front of the dump door to the back of the hopper.

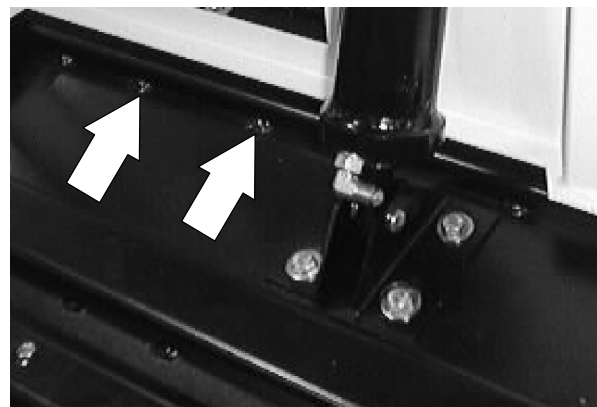

6. Use a razer knife to remove the RTV from the two dump door pivot bolts on each side of the hopper. Remove the two hex screws.

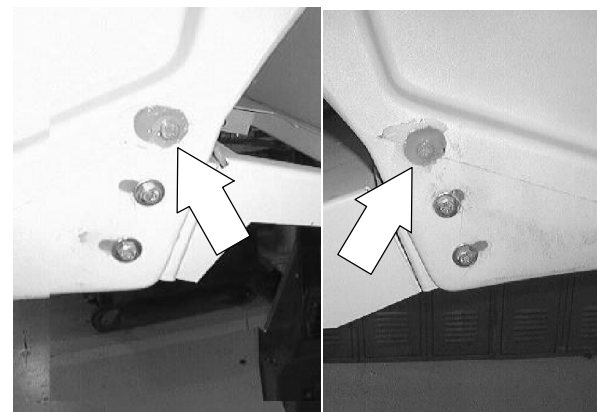

7. Drop the dump door down and out of the hopper.

## SWEEPING

### TO INSTALL HOPPER DUMP DOOR

1. Position the dump door in the hopper. Line up the pivot holes in the dump door with the mount holes in each side of the hopper.

**FOR SAFETY: Before Leaving Or Servicing Machine; Stop On Level Surface, Set Parking Brake, Turn Off Machine And Remove Key.**

2. Install the two hex screws and nuts. Hand tighten tight.
3. Put a small amount of RTV around the two hex screws.
4. Reinstall the seal on the front of the dump door. Hand tighten the hex screws tight.

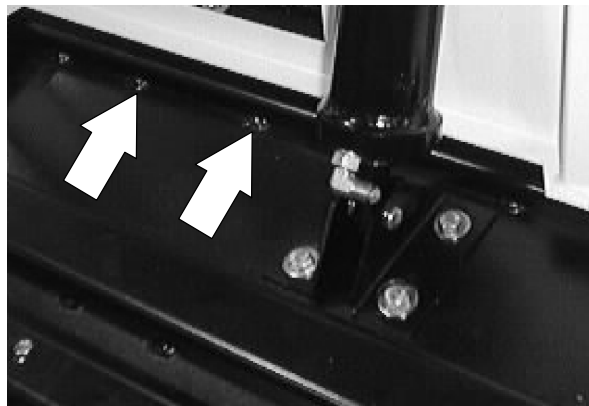
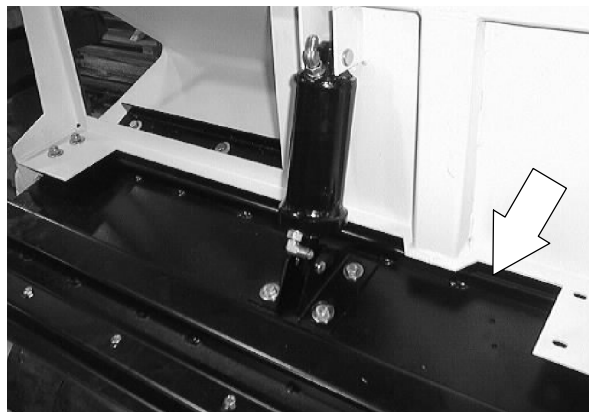

5. Reconnect the rod end of dump door cylinder to the mount bracket on the center of the dump door.

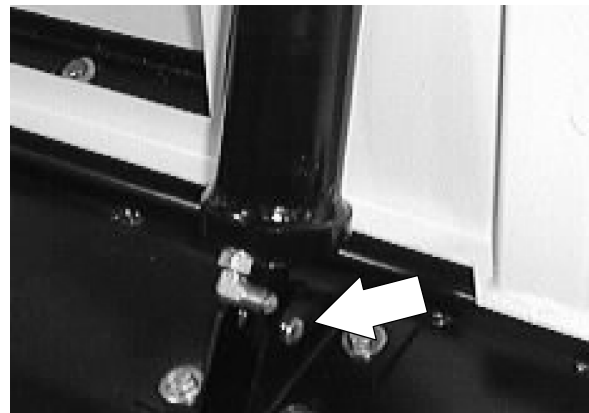

6. Start the machine and open and close hopper door a few times. Check for proper operation.

*NOTE: Make sure the seals on the dump door are adjusted so they contact the inside wall of the hopper.*

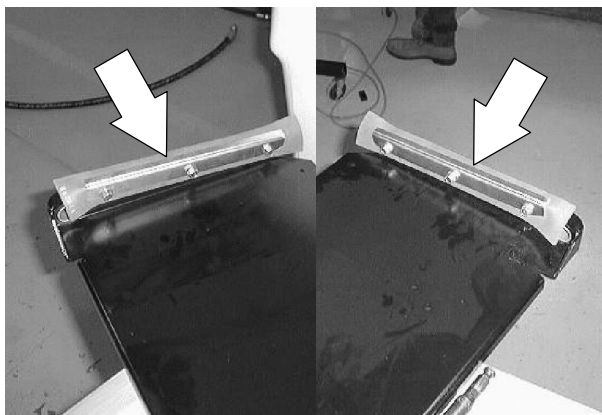



---

## HOPPER DUST FILTER

---

The dust filter filters the air pulled up from the hopper. The dust filter is equipped with a shaker to remove the accumulated dust particles. The dust filter shaker is operated by the filter shaker switch.

The standard dust filter works well for normal sweeping applications. The synthetic filter works well for humid or wet applications.

Shake the dust filter before dumping the hopper, at the end of every work shift, or when the optional filter clogged light is on. Check and clean or replace the dust filter every 100 hours of operation.

To clean the dust filter, use one of the following methods:

- **SHAKING** - Activate the shaker button.
- **TAPPING** - Tap the filter gently on a flat surface with the dirty side down. Do not damage the edges of the filter element or the filter will not seat properly in the filter frame.
- **AIR** - Always wear eye protection when using compressed air. Blow air through the dust filter opposite the direction of the arrows. Never use more than 690 kPa (100 psi) of air pressure and never closer than 50 mm (2 in) away from the filter. This may be done with the dust filter in the machine.

**FOR SAFETY: When Servicing Machine, Wear Eye And Ear Protection When Using Pressurized Air Or Water.**

- **WATER** - Rinse the synthetic filter with a low pressure garden hose through the dust filter opposite the direction of the arrows. The standard dust filter can also be rinsed, but the filter will degrade with each rinsing and should be replaced after rinsing five times.

*NOTE: Be sure the dust filter is dry before reinstalling it in the machine.*

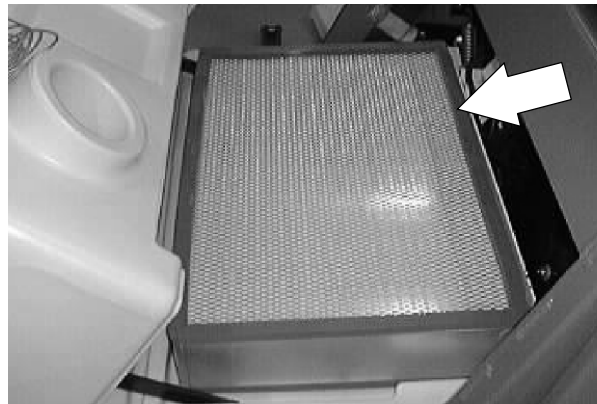

## SWEEPING

### TO REPLACE HOPPER DUST FILTER

1. Stop the engine and set the machine parking brake.

**FOR SAFETY: Before Leaving Or Servicing Machine; Stop On Level Surface, Set Parking Brake, Turn Off Machine And Remove Key.**

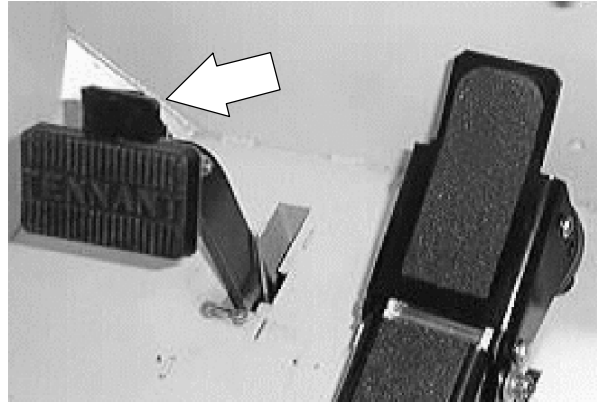

2. Open the hopper cover.

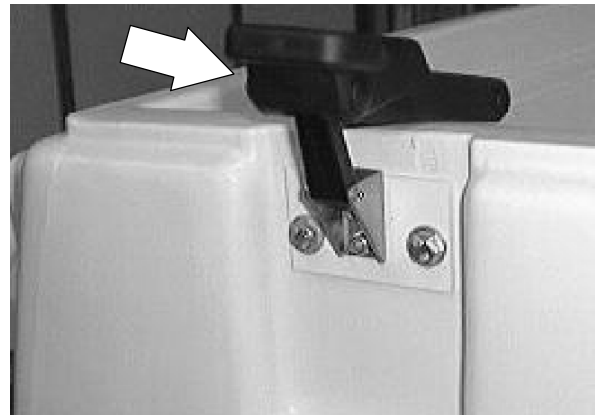

3. Pull the filter up and out of the hopper. Discard the old filter.



4. Position the new filter in the hopper.

*NOTE: Make sure the seals on the new filter are not damaged.*

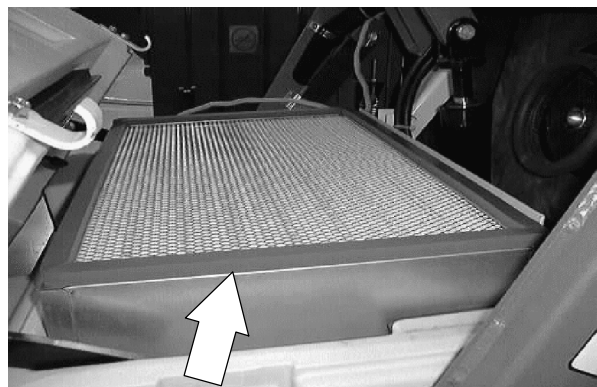

5. Close the hopper cover.

**TO REMOVE FILTER SHAKER ASSEMBLY**

1. Stop the engine and set the machine parking brake.

**FOR SAFETY: Before Leaving Or Servicing Machine; Stop On Level Surface, Set Parking Brake, Turn Off Machine And Remove Key.**

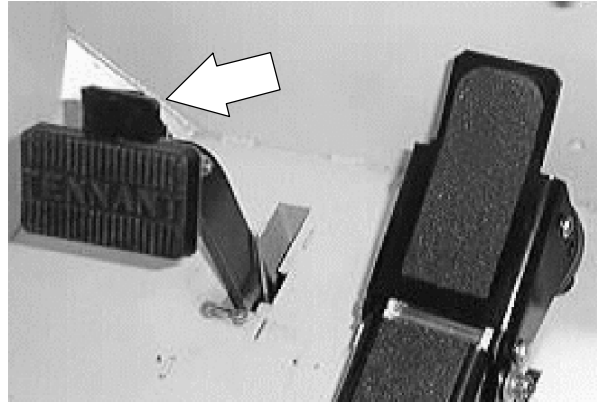

2. Open the hopper cover.

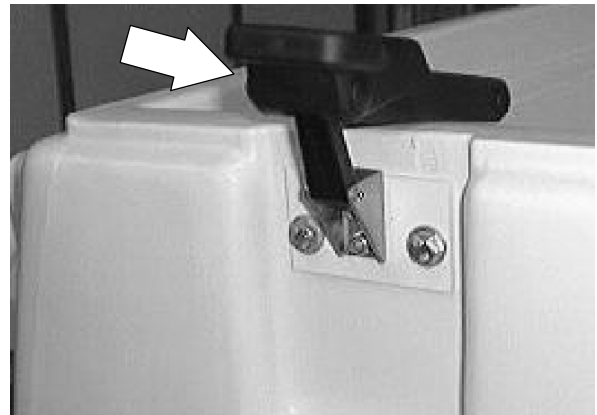

3. Disconnect the shaker motor and thermo sentry from the hopper harness.

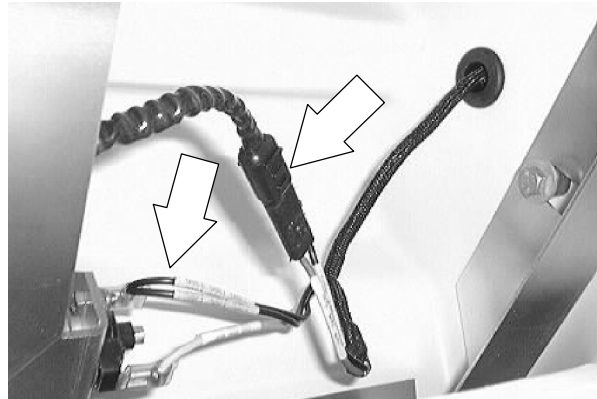

4. Remove the two hex screws holding the shaker assembly into the hopper cover.

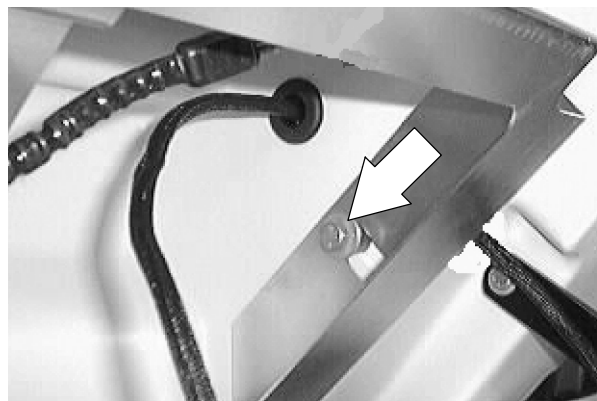

5. Remove the shaker assembly from the machine.

## SWEEPING

### TO INSTALL FILTER SHAKER ASSEMBLY

1. Stop the engine and set the machine parking brake.

**FOR SAFETY: Before Leaving Or Servicing Machine; Stop On Level Surface, Set Parking Brake, Turn Off Machine And Remove Key.**

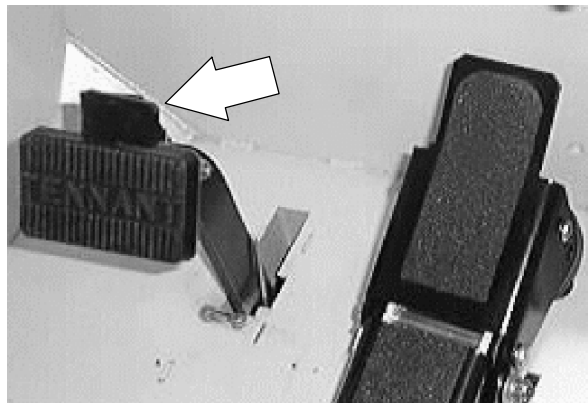

2. Open the hopper cover.

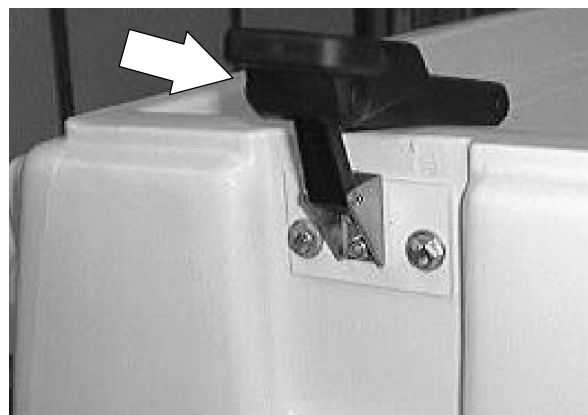

3. Position the shaker assembly into the hopper cover. Install the two hex screws and tighten to 18 - 24 Nm (15 - 20 ft lb).

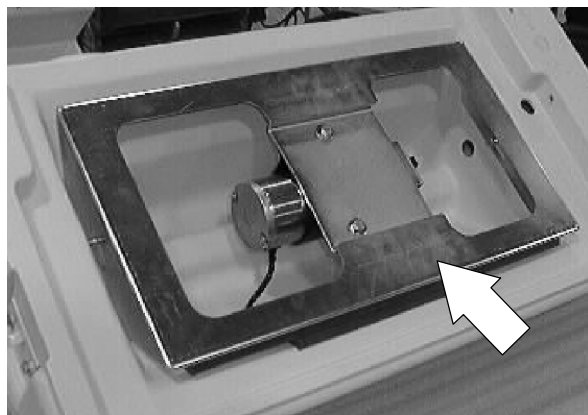

4. Connect the shaker motor and Thermo Sentry to the hopper harness.

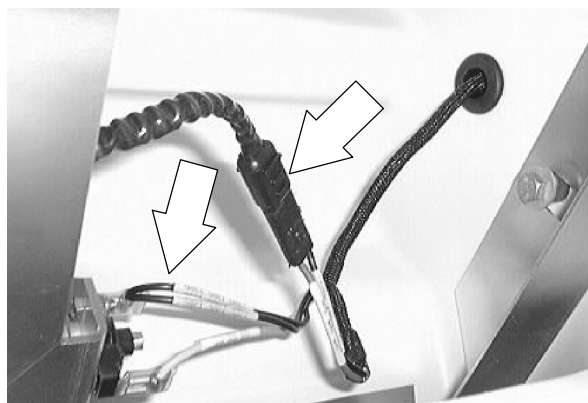

5. Close the hopper cover and engage the latches. Operate the shaker system. Check for proper operation.

## MAIN BRUSH

The main brush is cylindrical and spans the width of the machine. This brush is used to sweep debris into the hopper.

Check the brush daily for wear or damage. Remove any string or wire tangled on the main brush, main brush drive hub, or main brush idler hub.

Check the main brush pattern daily. The pattern should be 65 to 75 mm (2.5 to 3.5 in) wide with the main brush in the **Down** position. Adjust the main brush pattern by turning the adjustment knob for more or less pattern.

Rotate the main brush end-for-end every 50 hours of operation for maximum brush life and best sweeping performance. Replace the main brush when the remaining bristles measure 30 mm (1-1/4 in) in length.

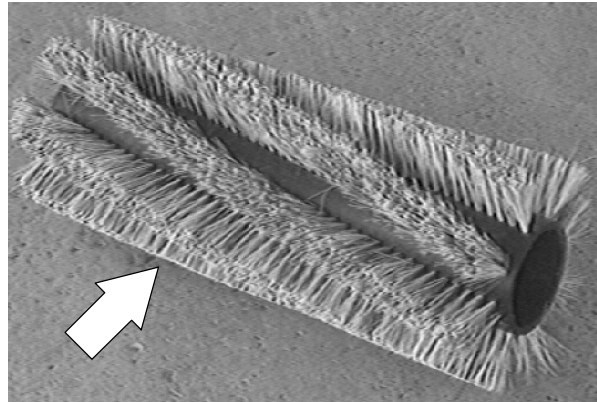

## TO REPLACE MAIN BRUSH

1. Stop the engine and set the machine parking brake.

**FOR SAFETY: Before Leaving Or Servicing Machine; Stop On Level Surface, Set Parking Brake, Turn Off Machine And Remove Key.**

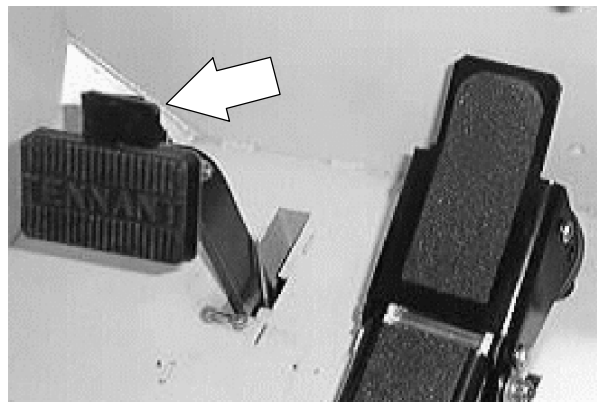

2. Raise the main brush.



## SWEEPING

3. Remove the clevis pin from the end of the scrub head guide arm where it is attached to the scrub head. Pivot the scrub head guide arm out, away from the right side brush door.

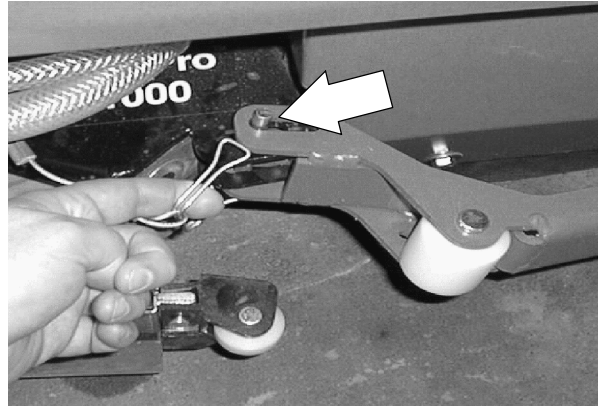

4. Open the right side main brush access door.



5. Unscrew the "T" nut and remove the brush idler plate.

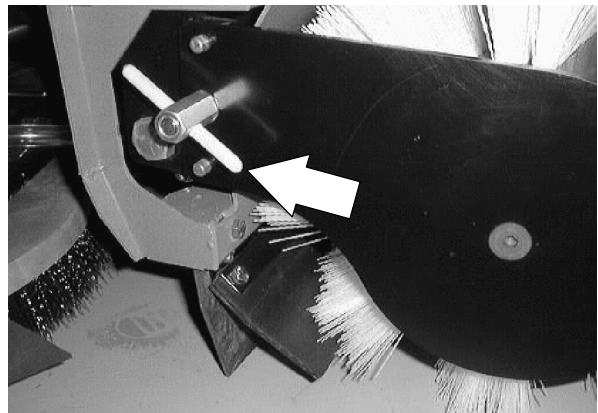

6. Grasp the main brush; pull it off the brush drive plug and out of the main brush compartment.

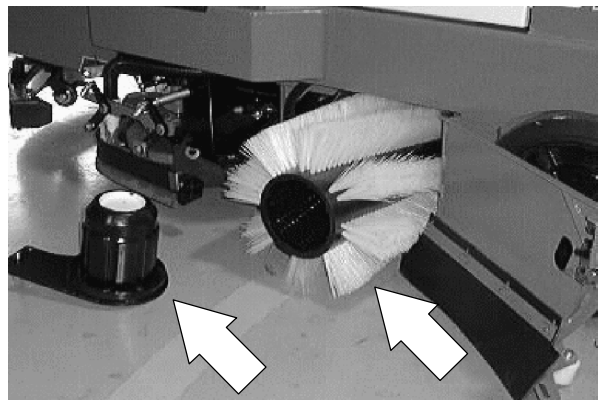

- Put the new or rotated end-for-end main brush on the floor next to the access door.

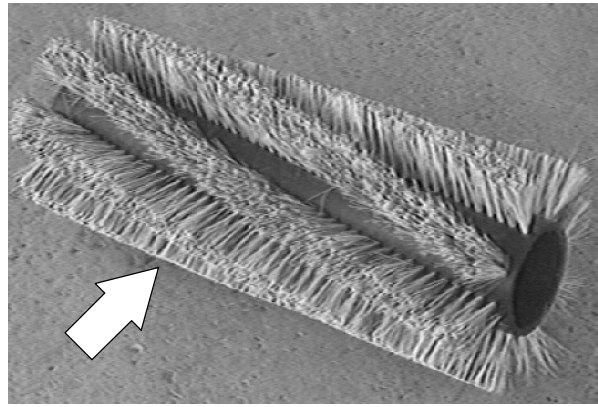

- Slide the main brush onto the drive plug. Rotate the brush until it engages the drive plug, and push it all the way onto the plug.

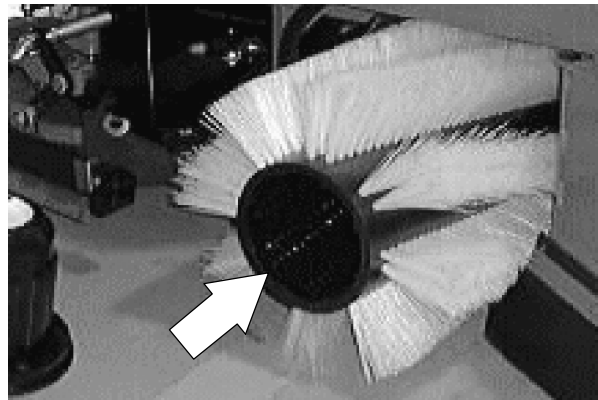

- Slide the main brush idler plate plug in the main brush.

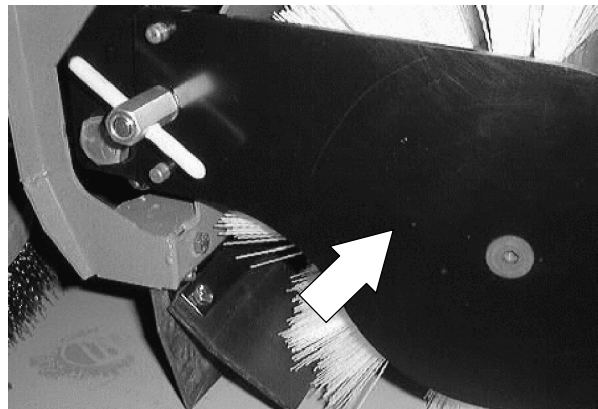

- Reinstall the "T" nut and hand tighten. The stop on the inside of the door will prevent the handle from loosening.

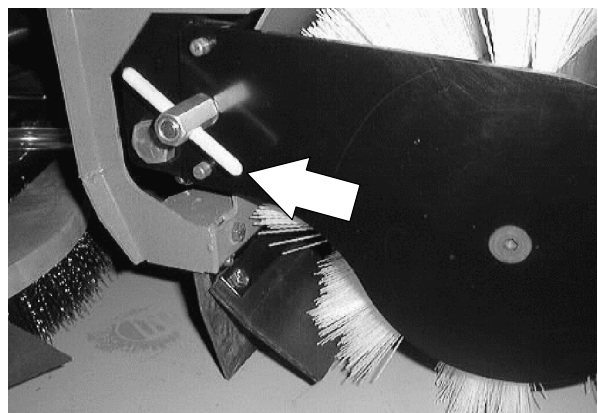

## SWEEPING

11. Close the right side main brush access door.

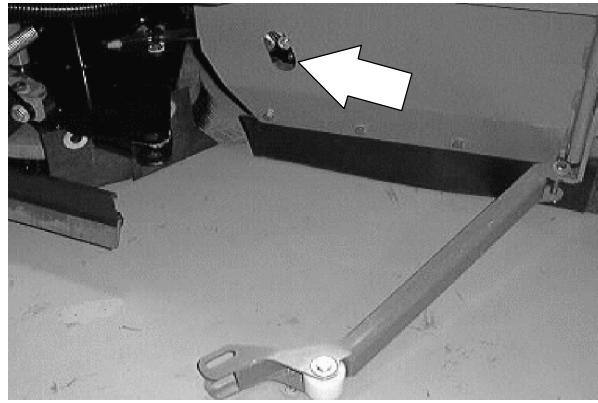

12. Pivot the scrub head guide arm back into place on the scrub head. Reinstall the clevis pin.

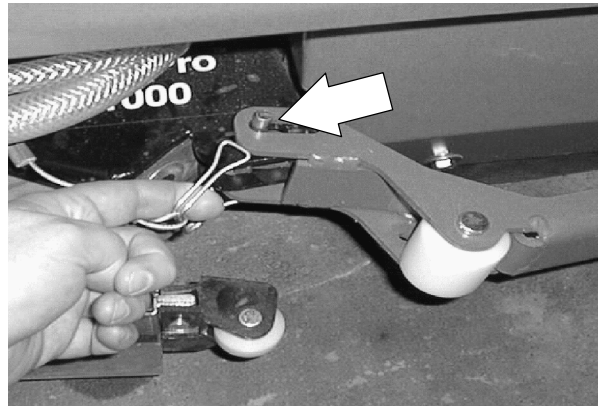

13. Operate the machine. Check the main brush pattern. See TO CHECK AND ADJUST MAIN BRUSH PATTERN instructions.

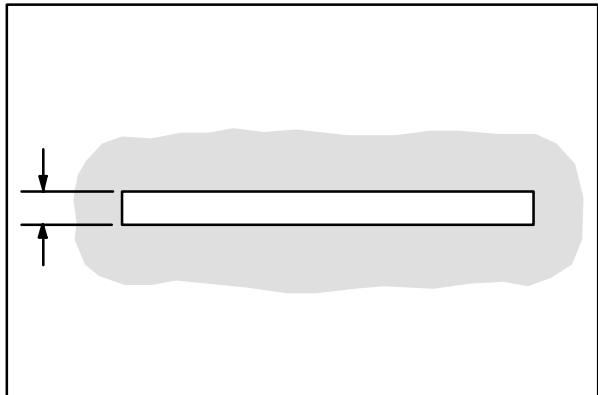



## TO CHECK AND ADJUST MAIN BRUSH PATTERN

1. Apply chalk, or some other material that will not blow away easily, to a smooth, level floor.
2. Raise the side brush and main brush and position the main brush over the chalked area.
3. Start the main brush.
4. Lower the main brush for 15 to 20 seconds while keeping a foot on the brakes to keep the machine from moving.

*NOTE: If chalk or other material is not available, allow the brushes to spin on the floor for two minutes. A polish mark will remain on the floor.*

5. Raise the main brush. The main brush will stop automatically.
6. Drive the machine off the test area.
7. Observe the width of the brush pattern. The proper brush pattern width is 65 to 75 mm (2.5 to 3.5 in).

*NOTE: Heavier brush pattern may be required for rough or uneven floors.*

8. To increase the width of the main brush pattern, rotate the main brush pattern adjustment knob counter-clockwise.

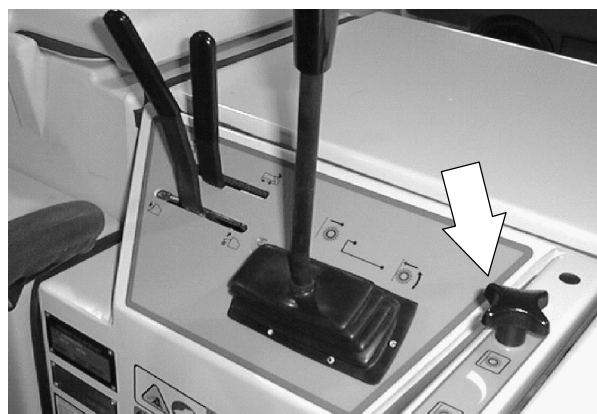
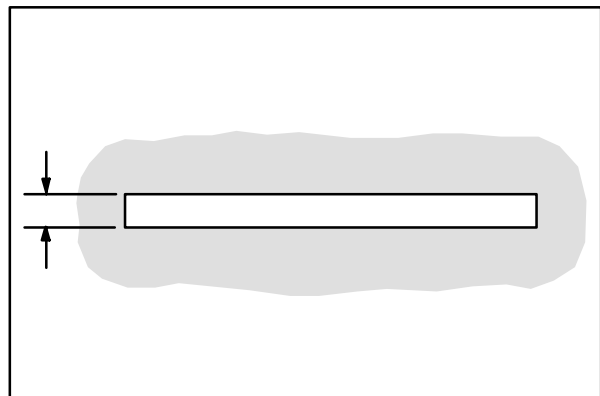
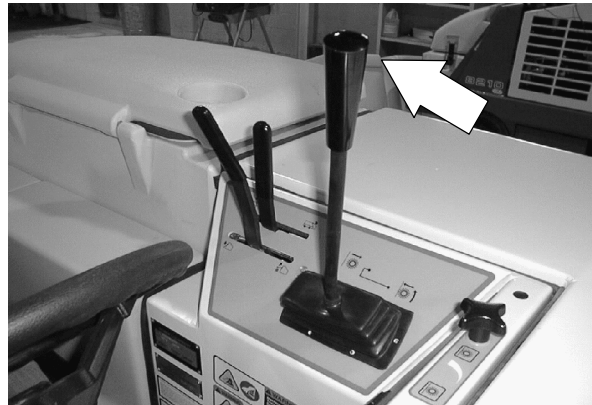

## SWEEPING

To decrease the width of the main brush pattern, rotate the main brush pattern adjustment knob clockwise.

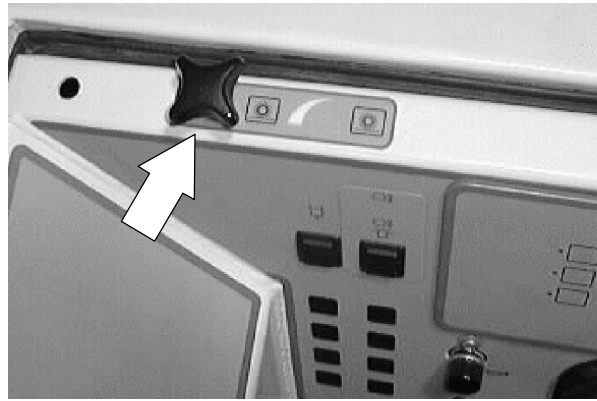

If the main brush pattern is tapered, more than 15 mm (0.5 in) on one end than the other, adjust taper.

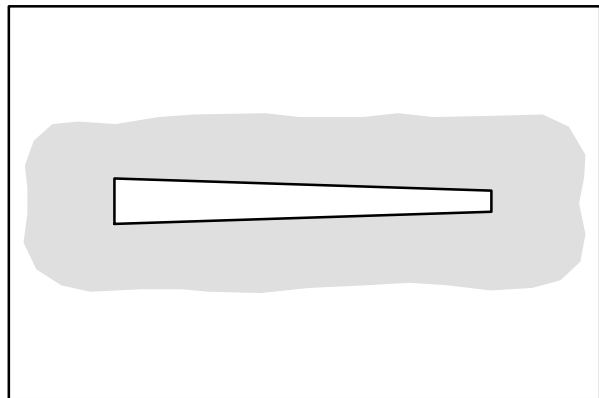

- A. Loosen the brush shaft bearing bracket mounting bolts.

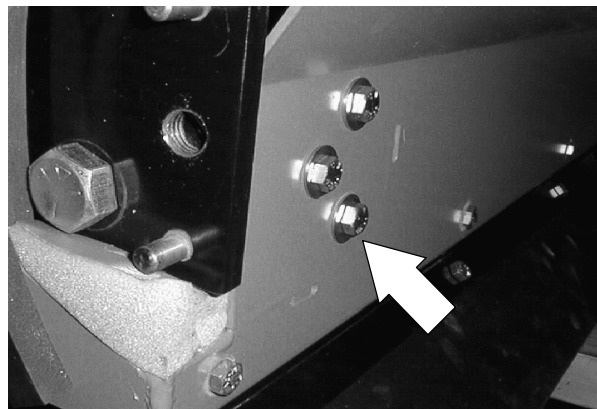

- B. Move the brush shaft bearing bracket up or down in the slots.

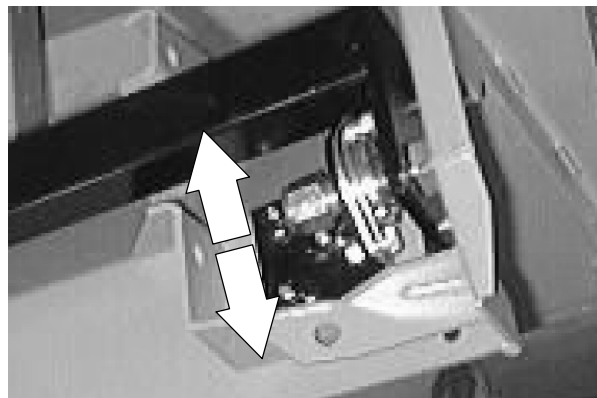

- C. Re-check the main brush pattern and readjust as necessary. Then adjust the width of the main brush pattern.

**TO REPLACE MAIN BRUSH IDLER PLUG BEARING**

**FOR SAFETY: Before Leaving Or Servicing Machine; Stop On Level Surface, Set Parking Brake, Turn Off Machine And Remove Key.**

1. Stop the engine and set the machine parking brake.

**FOR SAFETY: Before Leaving Or Servicing Machine; Stop On Level Surface, Set Parking Brake, Turn Off Machine And Remove Key.**

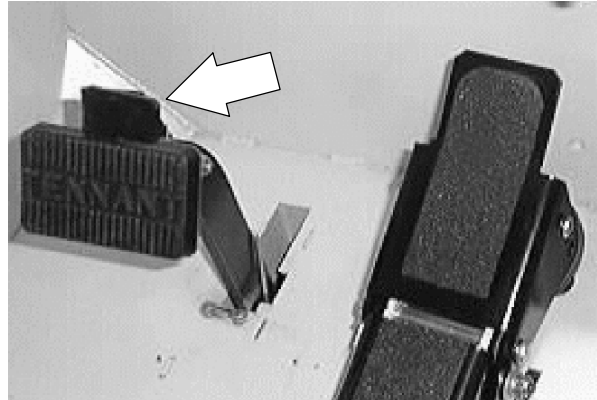

2. Raise the main brush.

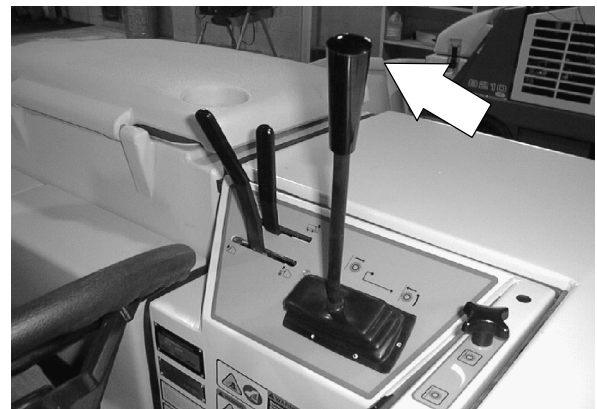

3. Remove the clevis pin from the end of the scrub head guide arm where it is attached to the scrub head. Pivot the scrub head guide arm out, away from the right side brush door.

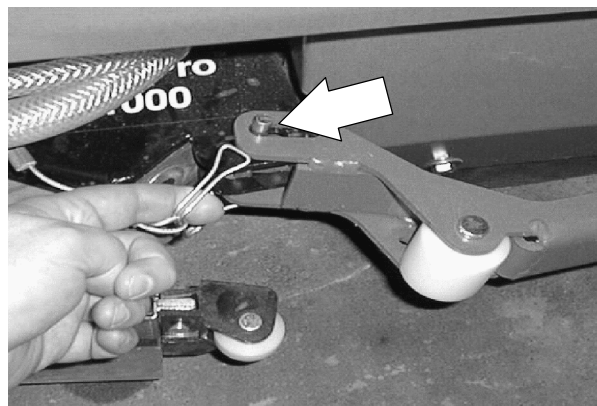

## SWEEPING

4. Open the right side main brush access door.



5. Unscrew the "T" nut.

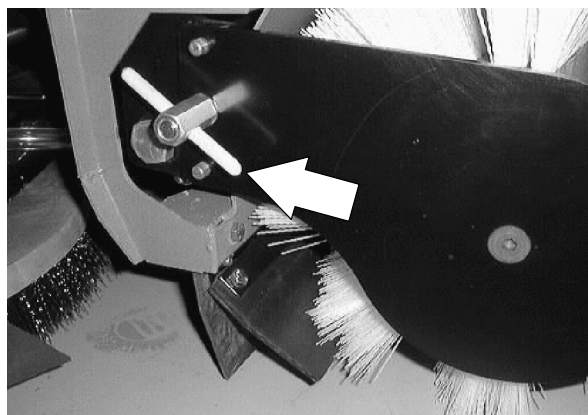

6. Remove the brush idler plate.

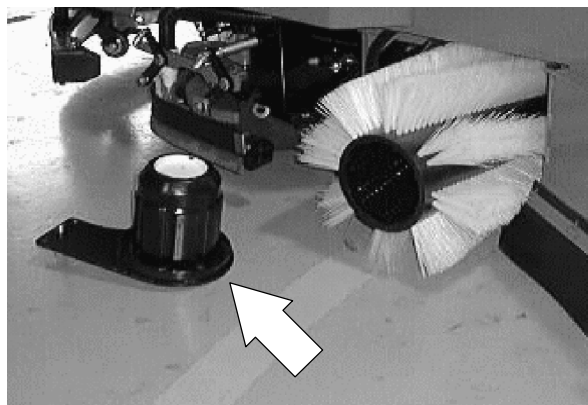

7. Remove the plastic cap from the idler plug.

8. Clean the area around where the cap was mounted in the idler plug.

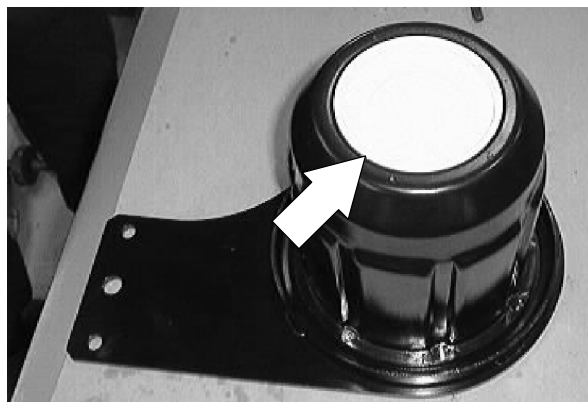

9. Remove the M12 flat screw, nyloc hex nut, and washer holding the idler plug to the idler arm.

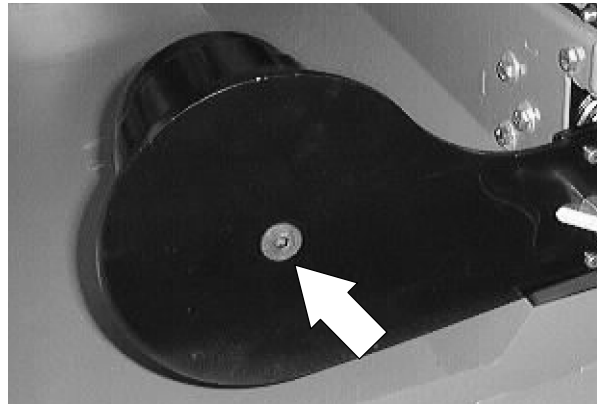

10. Remove the four M6 hex screws holding the idler shaft in the idler plug. Remove the shaft and cover.

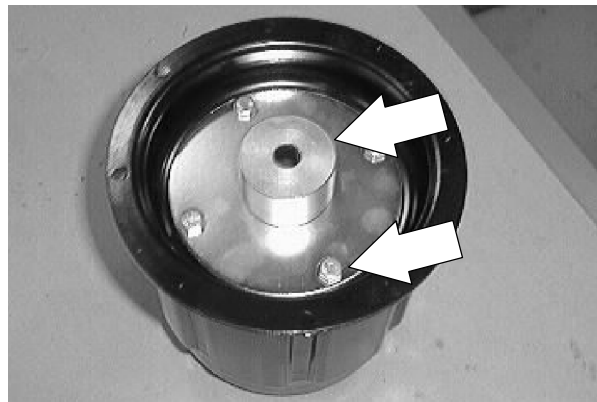

11. Remove the bearing seal plate, retainer and bearing.

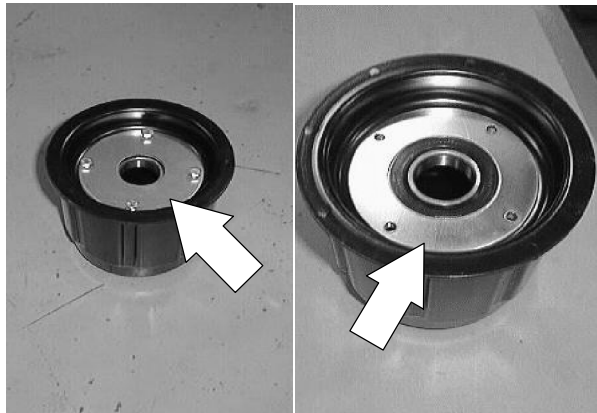

12. Place a new bearing, the old seal plate, and the retainer on the idler.



## SWEEPING

13. Reinstall the four hex screws that hold the bearing seal plate and retainer in place.

*NOTE: Leave screws loose for now.*



14. Install the idler shaft in the new bearing. Tighten the four hex screws to 8–10 Nm (6–8 ft lb).

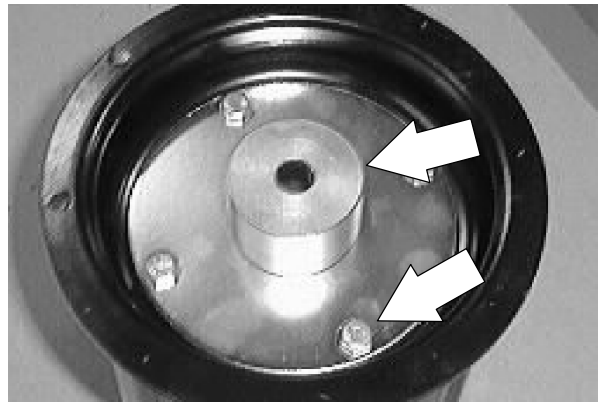

15. Position the idler plug on the idler arm shaft. Reinstall the long flat head screw. Tighten to 68–81 Nm (50–60 ft lb).

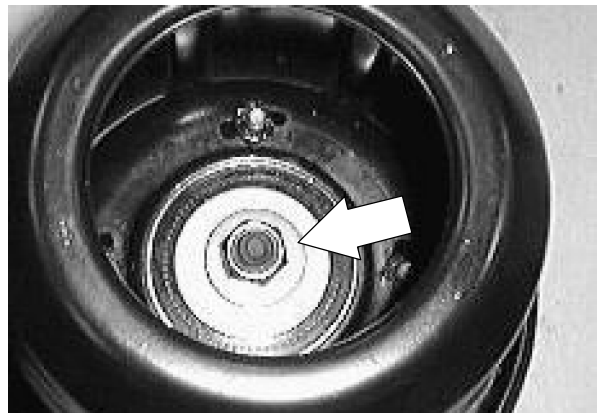

16. Put a small amount of RTV on the lip of the plastic cap and install in the end of the idler plug.



17. Reinstall the idler arm on the machine.

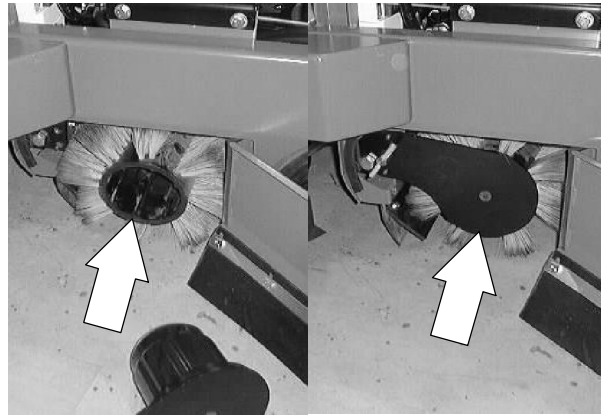

18. Operate the machine and check for proper operation.

## **SWEEPING**

### **TO REPLACE MAIN BRUSH SHAFT BEARINGS**

**FOR SAFETY: Before Leaving Or Servicing Machine; Stop On Level Surface, Set Parking Brake, Turn Off Machine And Remove Key.**

1. Remove the main brush idler arm from the machine.

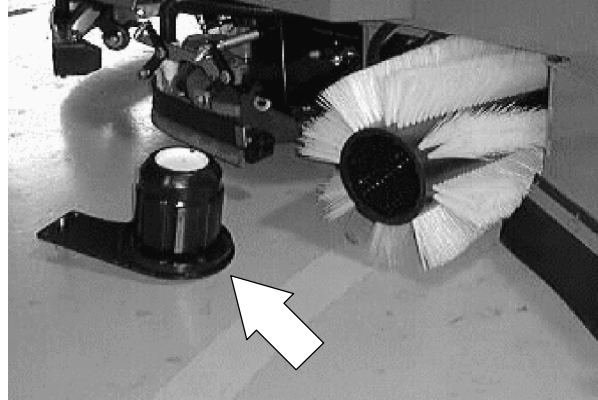

2. Remove the main brush motor arm assembly from the machine.

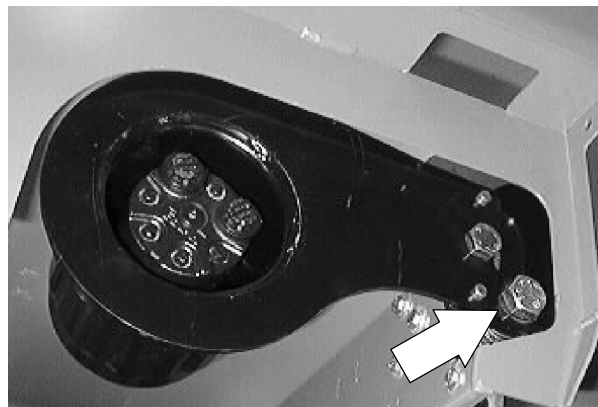

3. Remove the large hex screw and nyloc nut holding the brush arm to the pivot bearings.

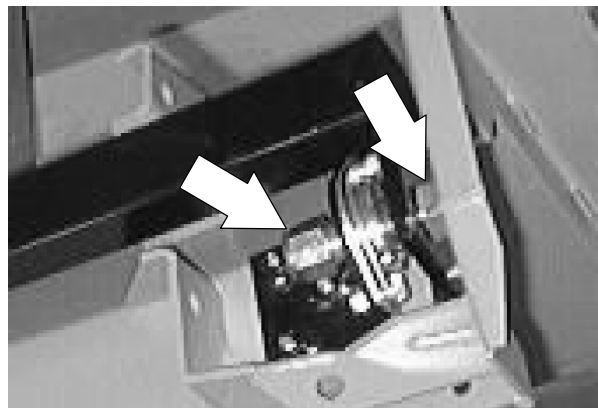



4. Let the brush arm drop down and out of the way.

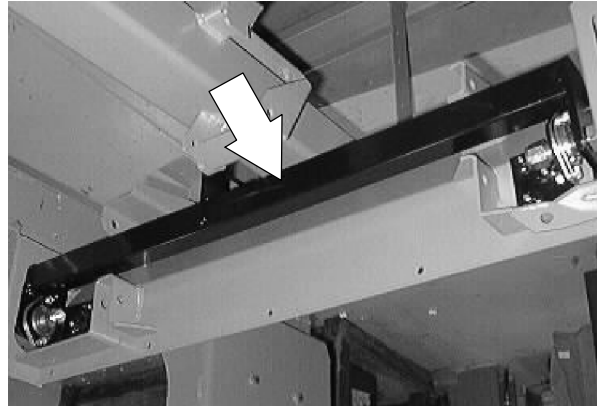

5. Remove the two bolts holding each of the two brush shaft bearings and retainers to the bearing brackets.

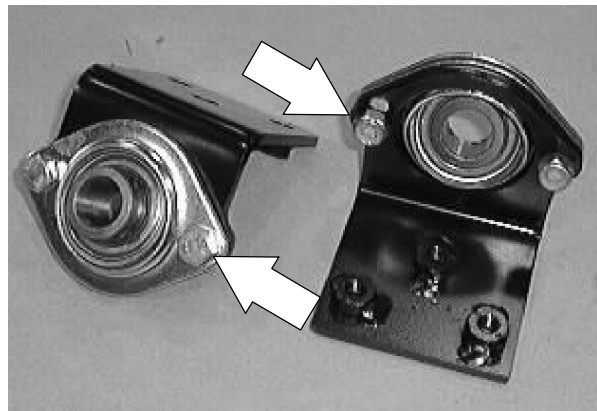

6. Remove the old brush shaft bearings.



7. Position the new brush shaft bearings on the mount brackets. Make sure to have the lock collars pointing to the outside of the machine.

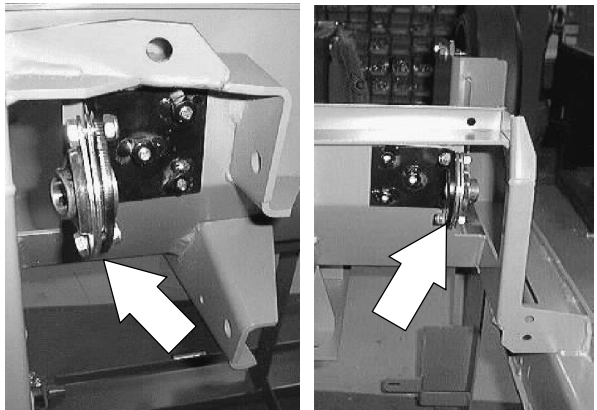

## SWEEPING

8. Reinstall the two bolts holding each of the two brush shaft bearings and retainers to the bearing brackets. Tighten to 18 - 24 Nm (15 - 20 ft lb).

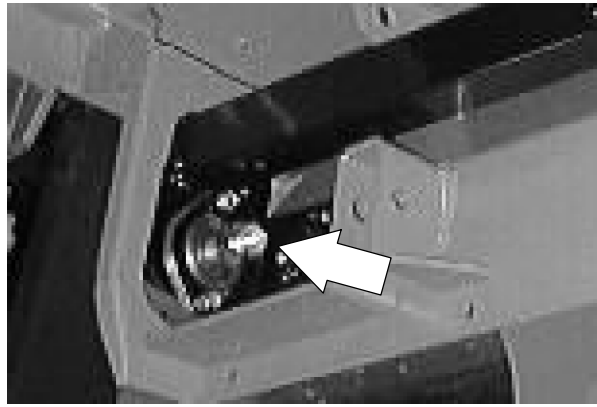

9. Reinstall the main brush motor plate and idler plate.

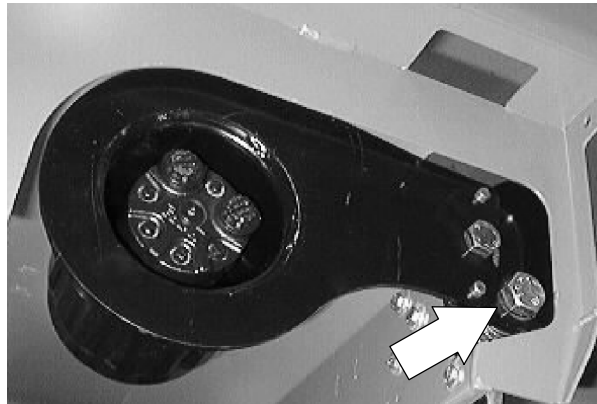

10. Check main brush pattern for taper and width. Adjust as necessary. See TO CHECK AND ADJUST MAIN BRUSH PATTERN.

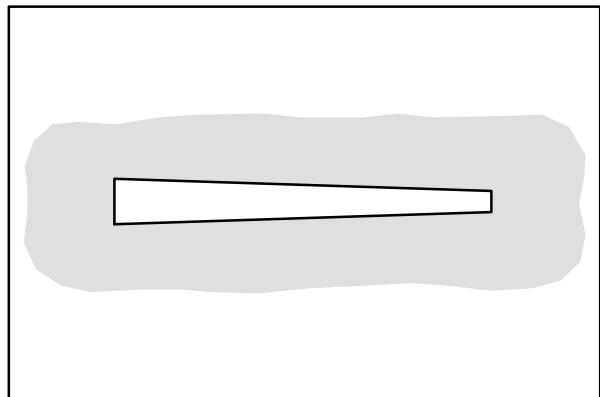

## SIDE BRUSH

The side brush sweeps debris along edges into the path of the main brush.

Check the brush daily for wear or damage. Remove any string or wire found tangled on the side brush or side brush drive hub.

Check the side brush pattern daily. One-half of the side brush bristles should contact the floor in a 11:00 to 3:00 pattern (4° forward and 4° right) when the brush is in motion. Adjust the side brush down pressure lever. Turn the lever counter-clockwise to increase the brush contact with the sweeping surface, and clockwise to decrease the brush contact with the sweeping surface.

The side brush should be replaced when it no longer sweeps effectively for your application. A guideline length is when the remaining bristles measure 50 mm (2 in) in length. You may change the side brush sooner if you are sweeping light litter, or wear the bristles shorter if you are sweeping heavy debris.



### TO REPLACE SIDE BRUSH

1. Empty the debris hopper.

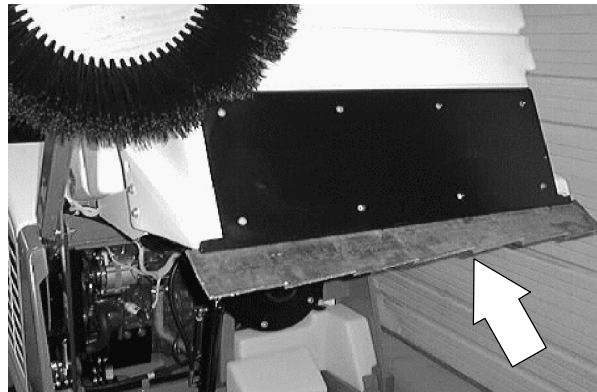

2. Set the machine parking brake.

**FOR SAFETY: Before Leaving Or Servicing Machine; Stop On Level Surface, Set Parking Brake, Turn Off Machine And Remove Key.**

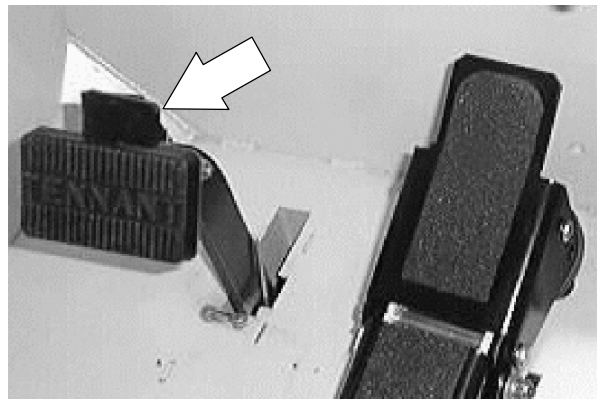

## SWEEPING

3. Raise the side brush.

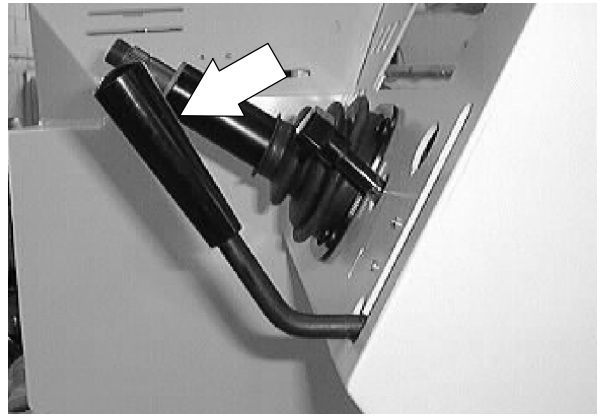

4. Remove the side brush retaining pin from the side brush drive shaft by pulling the pin keeper off and over the end of the pin. Remove the pin.

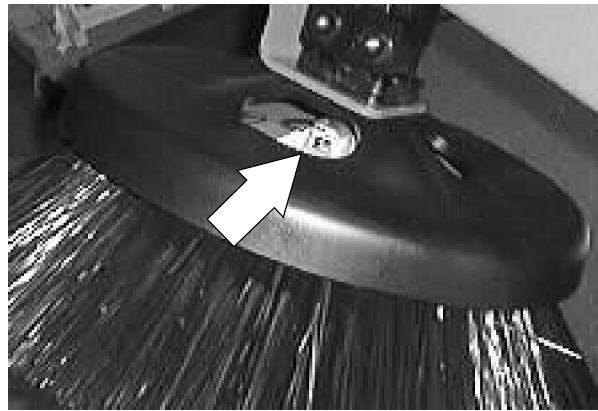

5. Slide the side brush off the side brush motor shaft.

*NOTE: Remove the drive hub and put it on the new brush if one is not installed.*

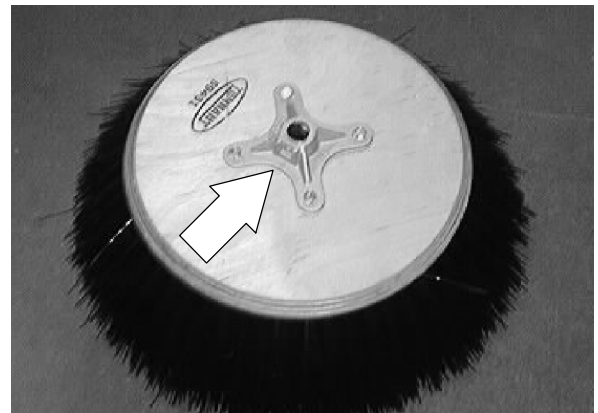

6. Slide the new side brush on the side brush motor shaft.



7. Reinstall the side brush retaining pin through the side brush hub and shaft.
8. Secure the pin by clipping the pin keeper over the end of the pin.

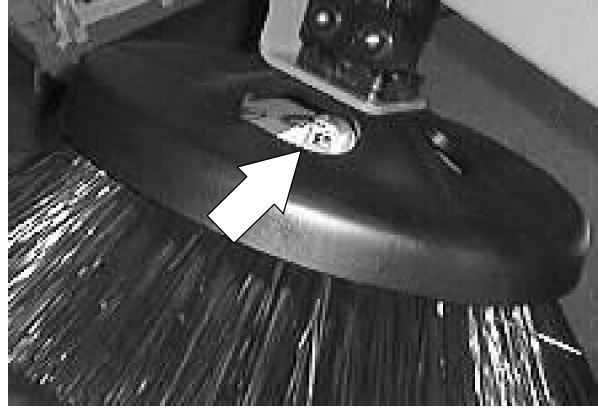

9. Disengage the hopper support bar and lower the hopper.

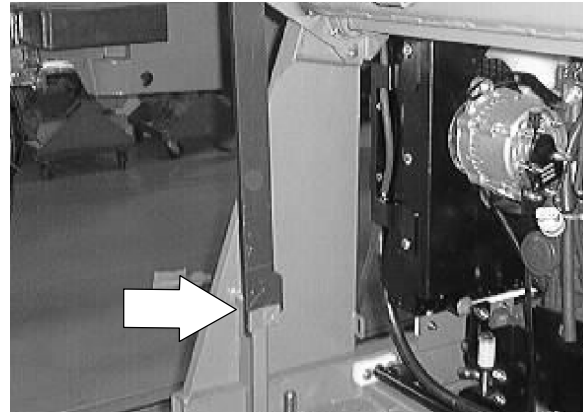

10. Adjust the side brush pattern with the side brush down pressure lever.

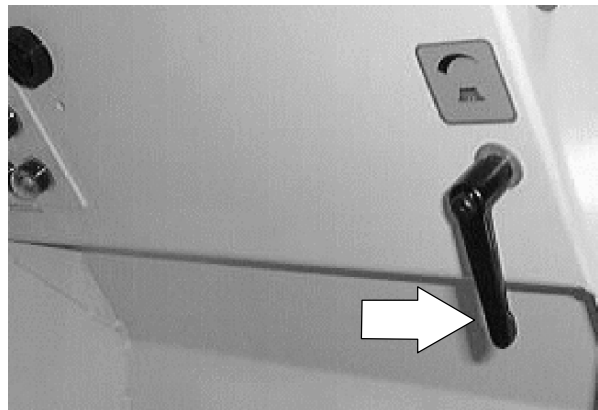

## SWEEPING

### TO ADJUST SIDE BRUSH PATTERN

**FOR SAFETY: Before Leaving Or Servicing Machine; Stop On Level Surface, Set Parking Brake, Turn Off Machine And Remove Key.**

1. Lower the side brush.

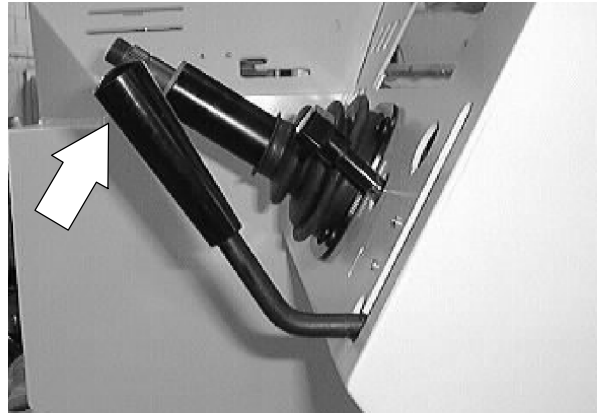

2. Turn the side brush lever clockwise to decrease side brush pattern. Turn the side brush lever counter-clockwise to increase side brush pattern.

*NOTE: One-half of the bristles should normally contact the floor.*

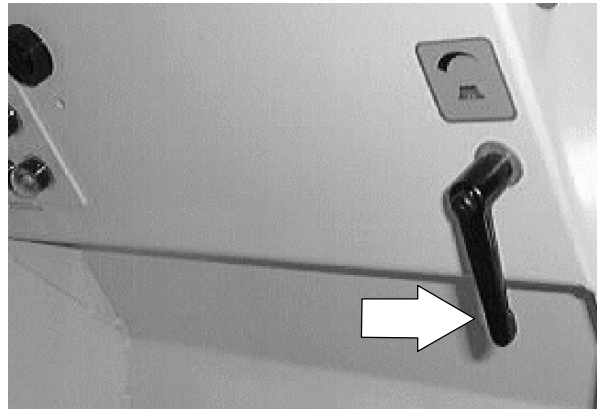

3. Raise the side brush.

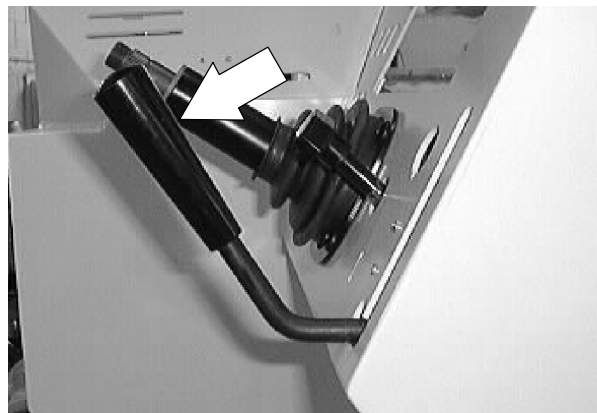

**TO ADJUST SIDE BRUSH LATERAL TILT PATTERN**

**FOR SAFETY: Before Leaving Or Servicing Machine; Stop On Level Surface, Set Parking Brake, Turn Off Machine And Remove Key.**

1. Lower the side brush.



2. Raise the hopper slightly and shut off the engine.

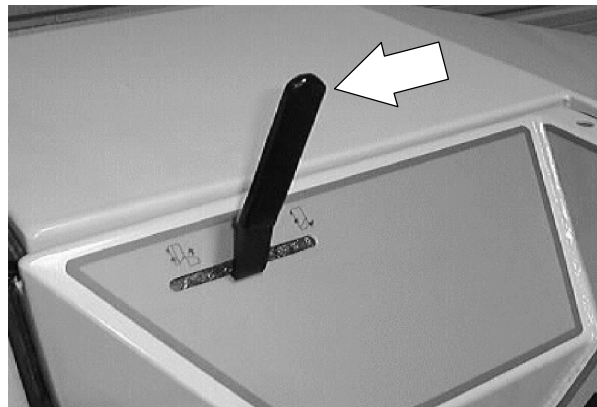

3. Loosen the two hex screws on the back of the hopper bumper near the side brush assembly.

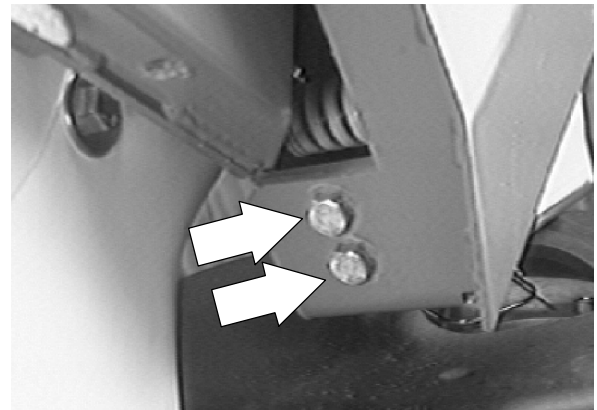

## SWEEPING

4. Tilt the side brush in either direction.

*NOTE: For the best performance in most applications--make a 4° forward and 4° right adjustment .*

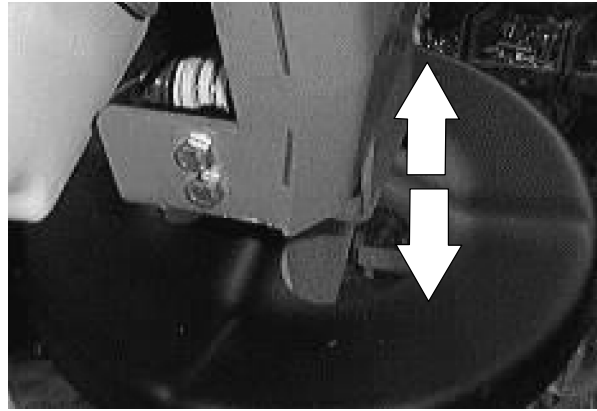

5. Tighten the hardware firmly.

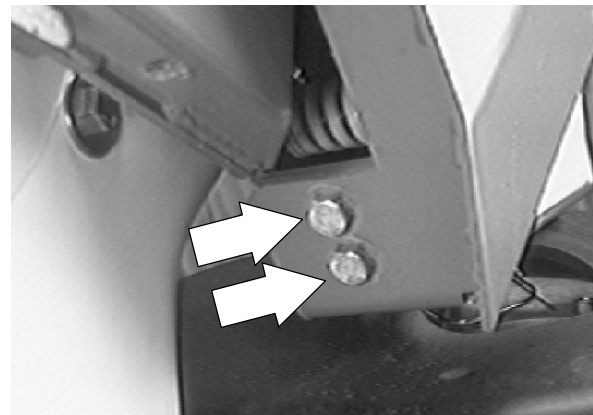

6. Lower the hopper.

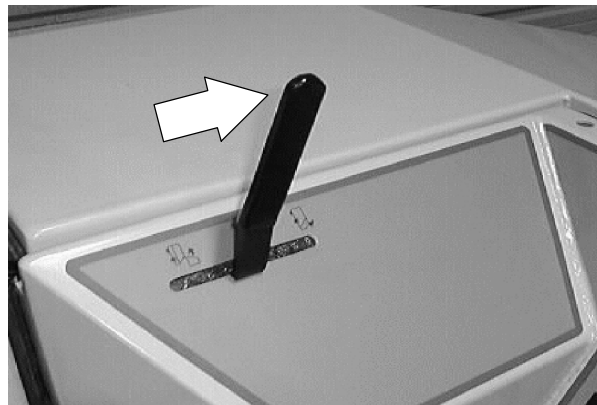

7. Start the engine and operate the side brush. Check the side brush pattern.

*NOTE: The side brush bristles should contact the floor in a 10 o'clock to 3 o'clock pattern when the brush is in motion.*

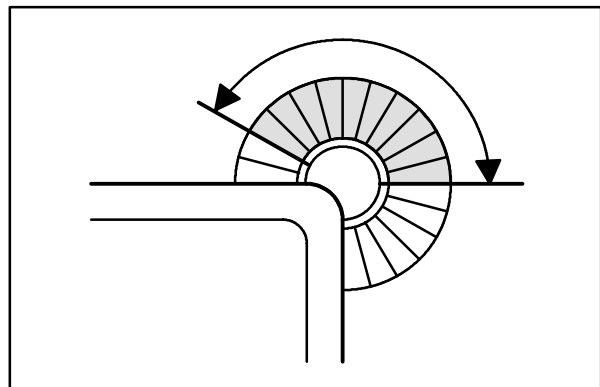



**TO ADJUST SIDE BRUSH FORE/AFT TILT PATTERN**

**FOR SAFETY: Before Leaving Or Servicing Machine; Stop On Level Surface, Set Parking Brake, Turn Off Machine And Remove Key.**

1. Lower the side brush.



2. Remove the hair pin from the clevis pin on the fore/aft tilt cable.

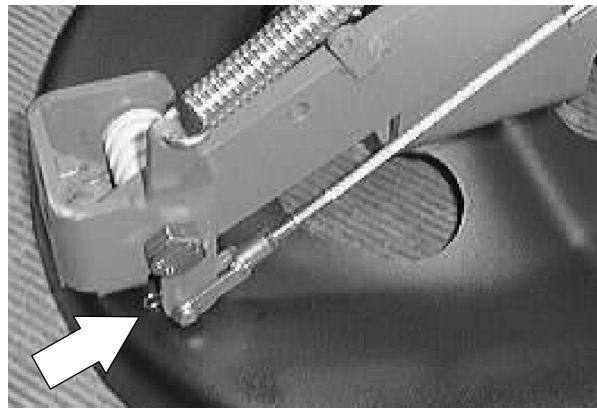

3. Loosen the jam nut near the clevis.

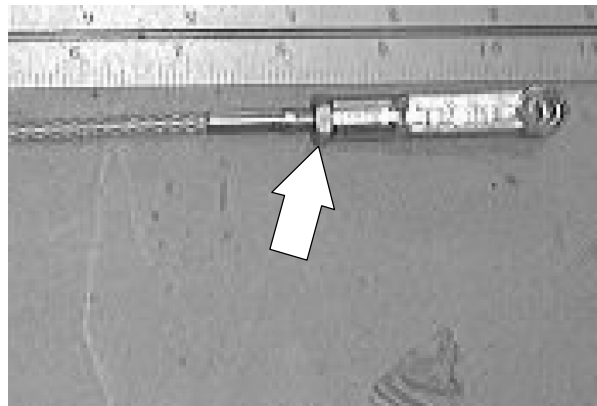

## SWEEPING

4. Remove the clevis pin and turn the clevis in or out to achieve proper fore/aft side brush adjustment.

*NOTE: The starting length of the cable should be 10.25 inch from the center of the clevis hole to the center of the cable ring.*

*NOTE: For a 4° forward angle--adjust the cable length to 10.25 inches from the center of the clevis pin to the center of the eyelet on the cable.*

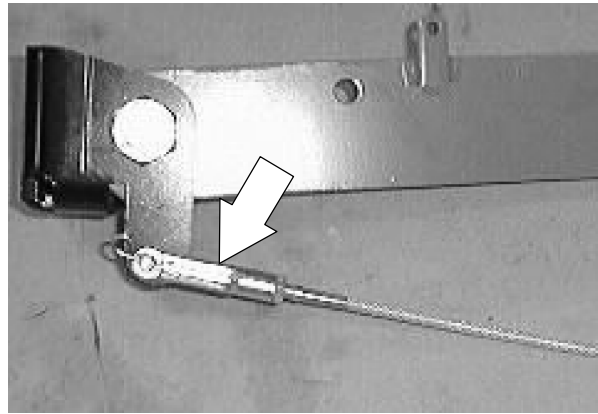

5. Reinstall the clevis pin and tighten the jam nut.

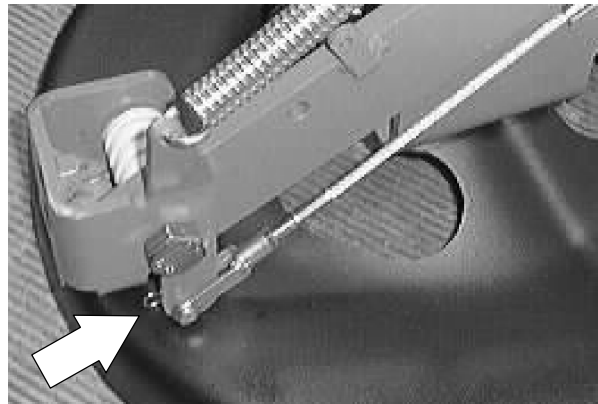

6. Start the engine and operate the side brush. Check the side brush pattern.

*NOTE: The side brush bristles should contact the floor in a 10 o'clock to 3 o'clock pattern when the brush is in motion.*

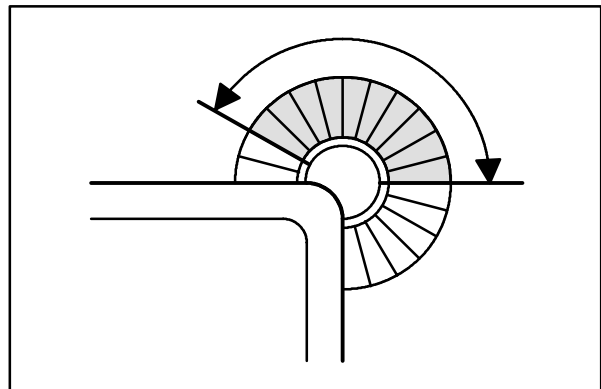

## SIDE BRUSH GUARD

The side brush guard protects the side brush from objects along path of the machine. It deflects the side brush out of harms way.

Rotate the side brush guard 90° every 200 hours of operation or as required. Replace the brush guard after all four sides have been used.



### TO ROTATE OR REPLACE SIDE BRUSH GUARD

**FOR SAFETY: Before Leaving Or Servicing Machine; Stop On Level Surface, Set Parking Brake, Turn Off Machine And Remove Key.**

1. Remove the side brush.

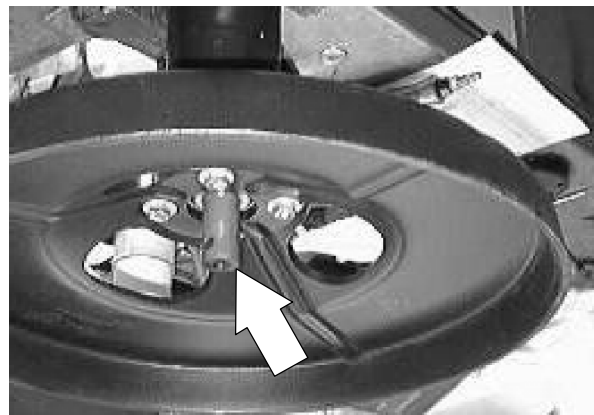

2. Remove the four hex screws holding the side brush guard to the side brush motor.

3. Rotate or replace the side brush guard.

4. Reinstall the four bolts in the side brush motor and tighten to 22-27 Nm (16-20 ft lb).

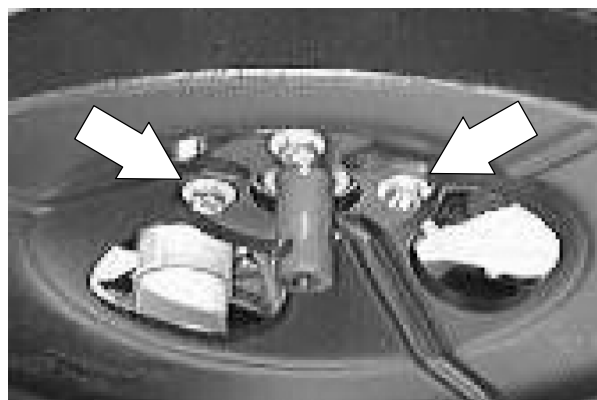

## SKIRTS AND SEALS

### HOPPER LIP SKIRT

The hopper lip skirt is located on the bottom rear of the hopper. The skirt floats over debris and helps deflect that debris into the hopper.

Check the hopper lip skirt for wear or damage daily. Replace the hopper lip skirt when it no longer touches the floor.



### TO REPLACE HOPPER LIP SKIRT

1. Dump the machine debris hopper.

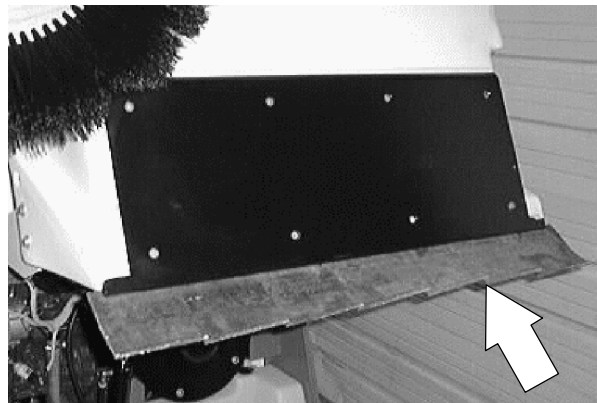

2. Set the machine parking brake.

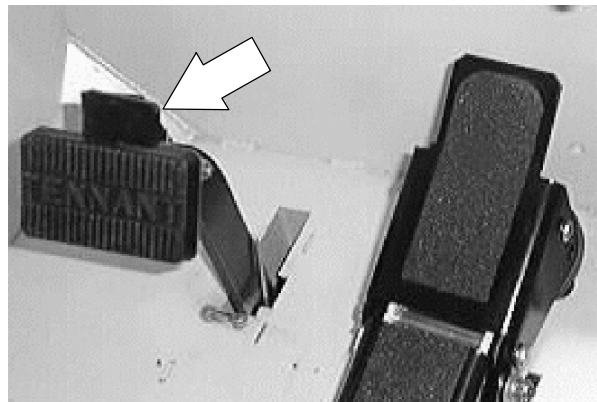

3. Raise the hopper, engage the hopper support bar. Shut off the engine.

 **WARNING: Raised Hopper May Fall. Engage Hopper Support Bar.**

**FOR SAFETY: Before Leaving Or Servicing Machine; Stop On Level Surface, Set Parking Brake, Turn Off Machine And Remove Key.**

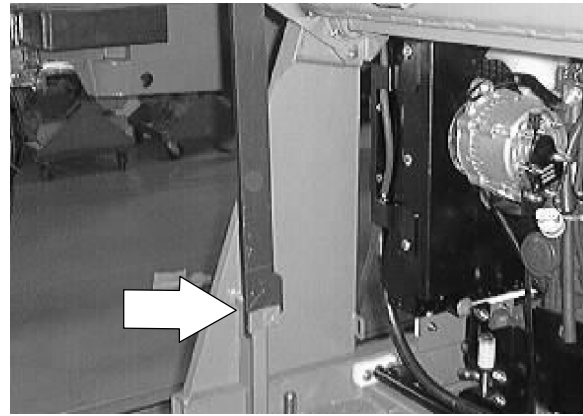

4. Remove the six hopper lip retainer strip mounting screws.

*NOTE: Retain the left and right debris deflectors.*

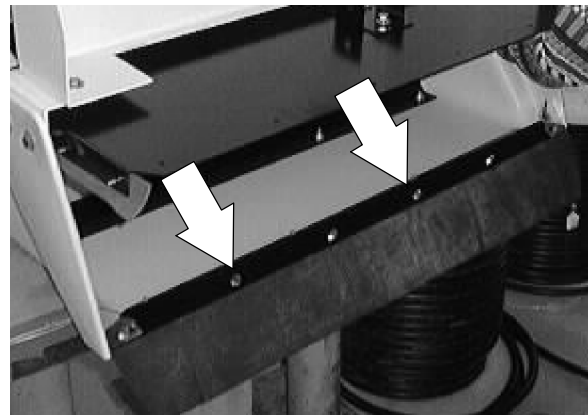

5. Loosen the four flat head screws holding the skirt retainer strip to the hopper.

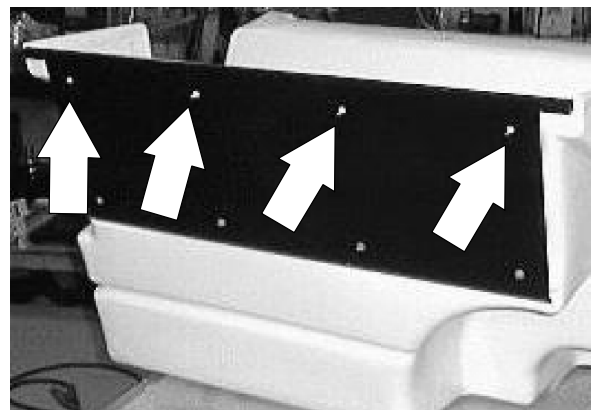

6. Remove the hopper lip skirt from the hopper.

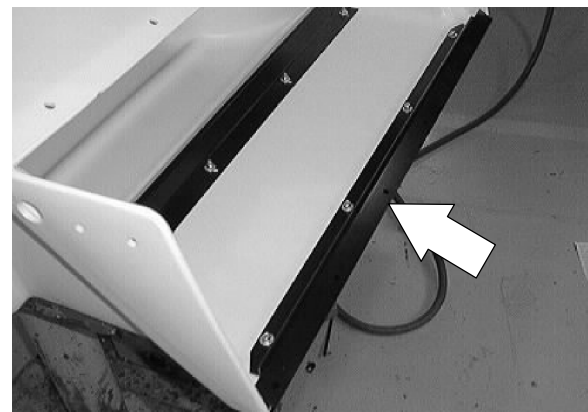

## SWEEPING

7. Install the new hopper lip skirt under the retainer strip. Line up the six mounting holes.

*NOTE: Reinstall the left and right debris deflectors.*

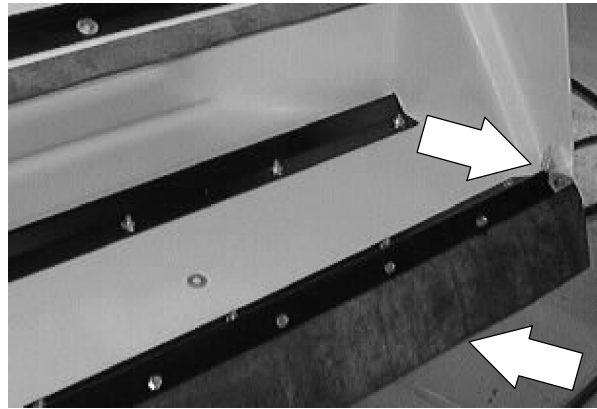

8. Reinstall the six thread rolling screws and hand tighten tight.

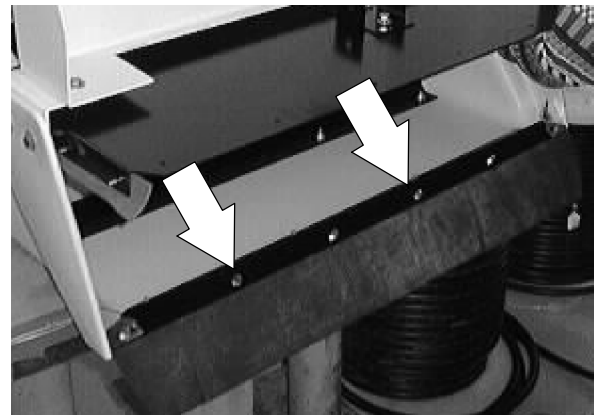

9. Tighten the four flat head screws to 8-14 Nm (6-10 ft lb).

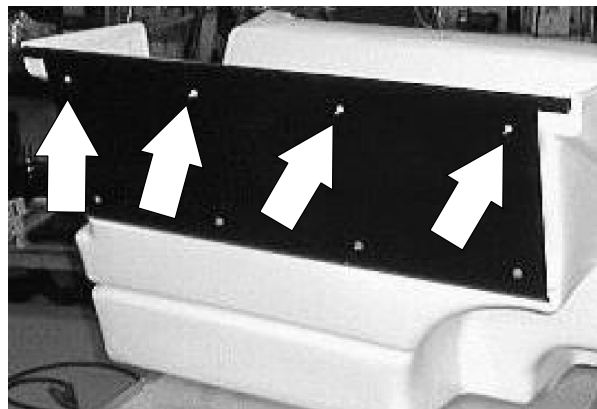

10. Start the engine and lower the hopper.

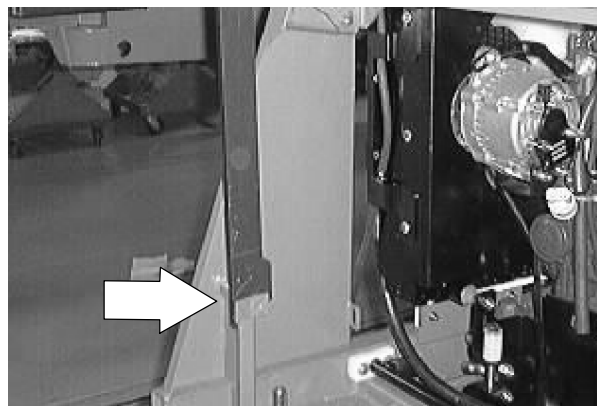

## BRUSH DOOR SKIRTS

The right hand brush door skirt is located on the bottom of the main brush door. The left hand skirt is located on a skirt mount plate bolted to the machine frame. Both skirts should clear the floor up to 5 mm (0.25 in) in dusty conditions, and touch the floor otherwise.

Check the skirts for wear or damage and adjustment daily.

*NOTE: The brush door skirts have slotted holes to allow for a ground clearance adjustment. The door must be closed for proper adjustment.*

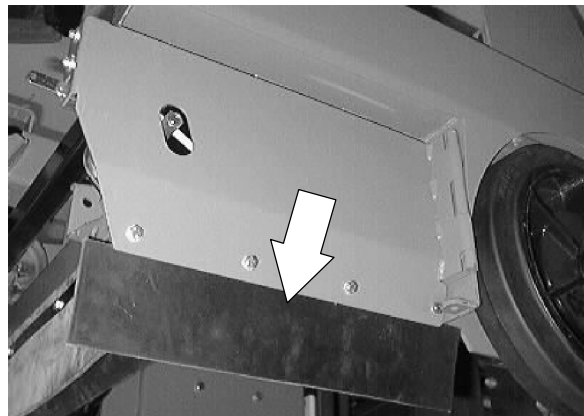

## TO REPLACE AND ADJUST RIGHT HAND BRUSH DOOR SKIRT

1. Stop the engine and set the machine parking brake.

**FOR SAFETY: Before Leaving Or Servicing Machine; Stop On Level Surface, Set Parking Brake, Turn Off Machine And Remove Key.**

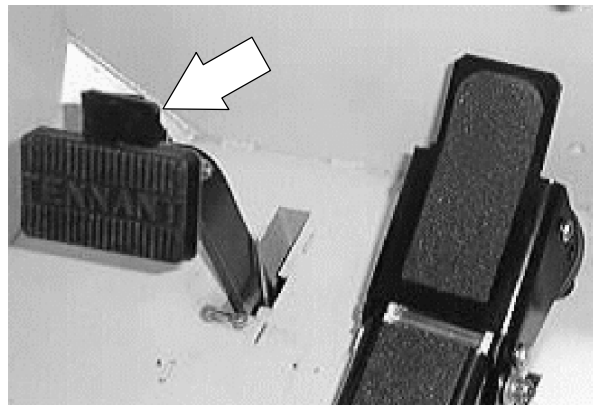

2. Remove the clevis pin from the end of the scrub head guide arm where it is attached to the scrub head. Pivot the scrub head arm out, away from the right side brush door.

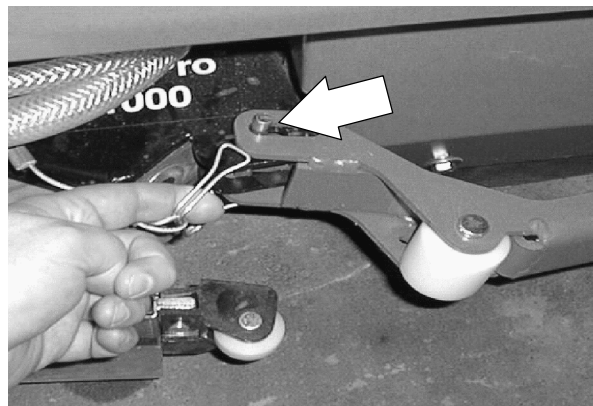

## SWEEPING

3. Open the right hand brush door.

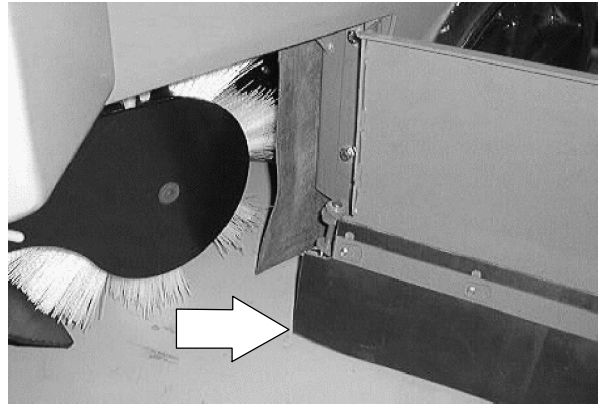

4. Remove the brush door skirt retaining bolts.

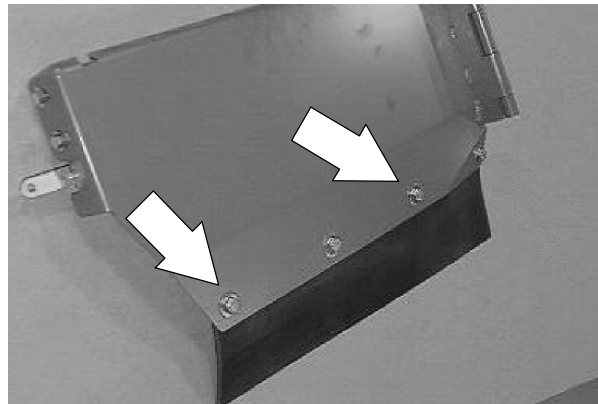

5. Remove the skirt retaining strip and door skirt.

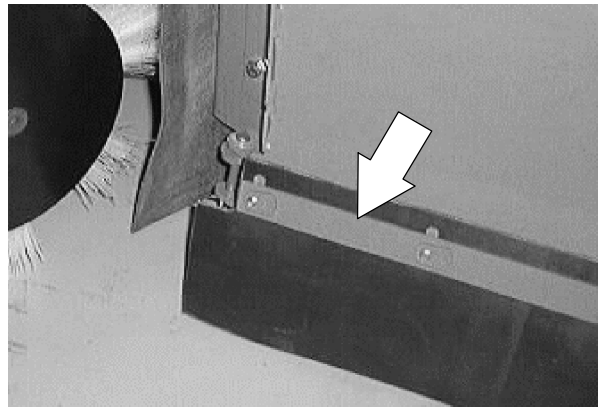

6. Position the new brush door skirt on the brush door with the cup of the skirt facing inward.

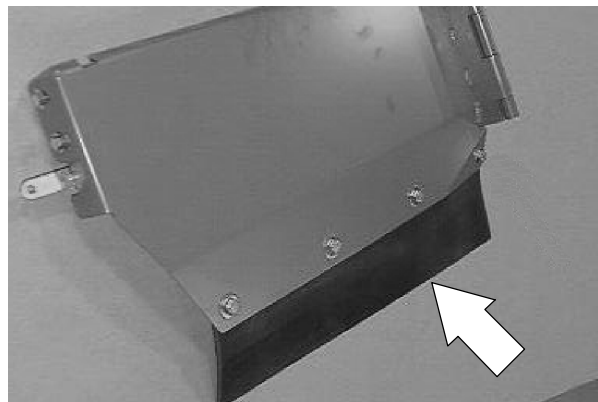



7. Position the retainer over the new skirt.

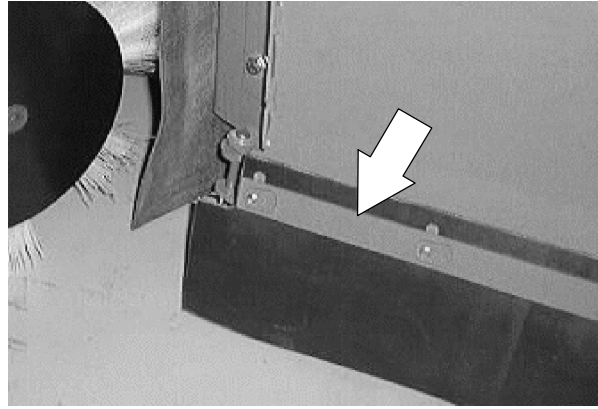

8. Thread the skirt retaining bolts through the brush door, the door skirt, and in the skirt retaining strip.

*NOTE: The brush door skirt has slotted holes to allow for a ground clearance adjustment. The door must be closed for proper adjustment.*

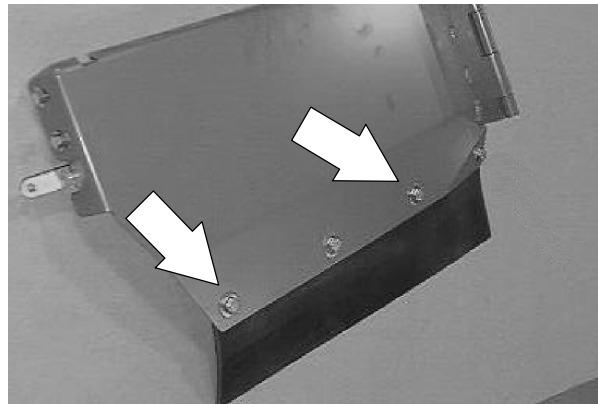

9. Slide the brush door skirt up or down so it will clear the floor by 3-5 mm (0.12 to 0.25 in).

*NOTE: Hand tighten the hex screws firmly.*

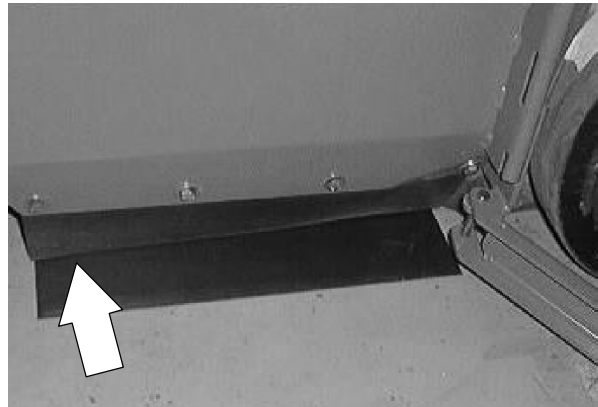

10. Close the right hand brush door.

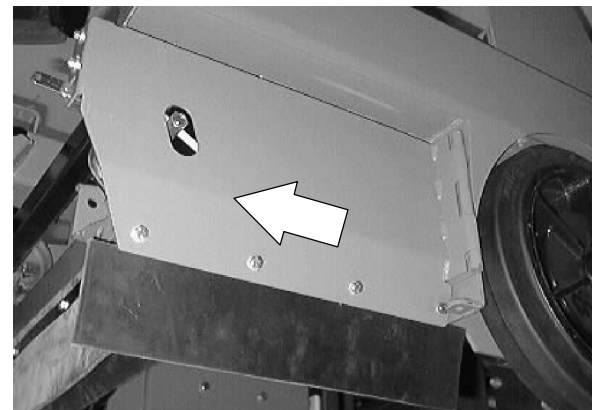

## SWEEPING

---

11. Pivot the scrub head guide arm back into place on the scrub head. Reinstall the clevis pin.

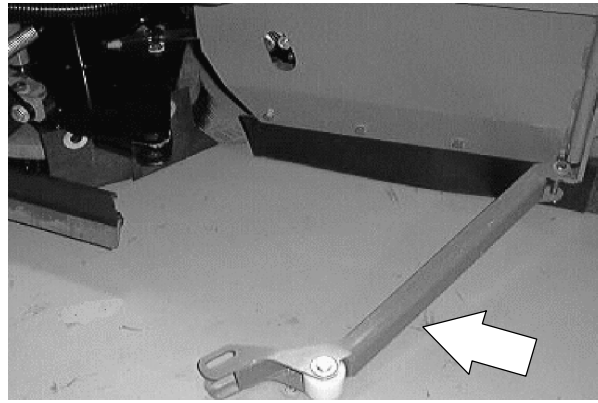

12. Operate the machine and check the new skirts for proper operation.

**TO REPLACE AND ADJUST LEFT HAND  
BRUSH DOOR SKIRT**

1. Stop the engine and set the machine parking brake.

**FOR SAFETY: Before Leaving Or Servicing Machine; Stop On Level Surface, Set Parking Brake, Turn Off Machine And Remove Key.**

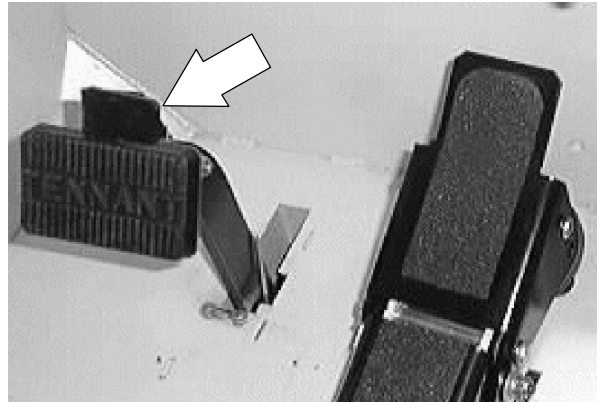

2. Remove the four hex screws holding the skirt mount plate door to the machine.

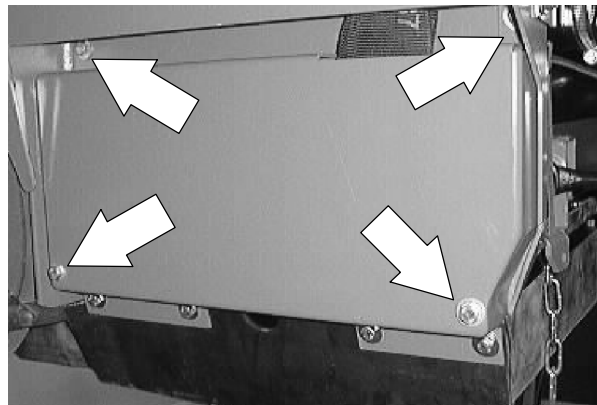

3. Remove the brush skirt retaining bolts and two retainers.

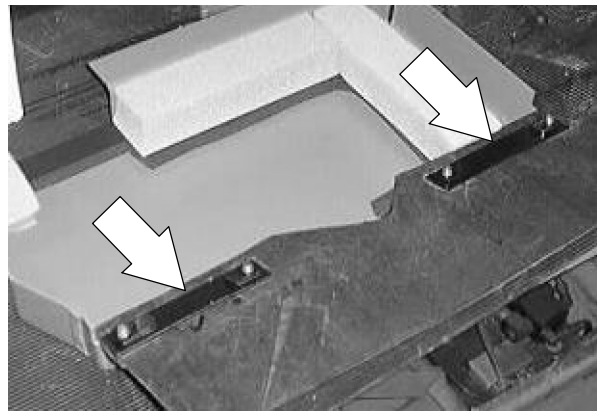

## SWEEPING

4. Remove the skirt from the door.

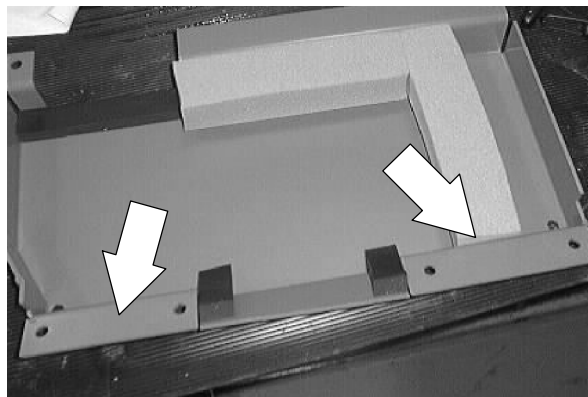

5. Position the new brush skirt on the mount plate.

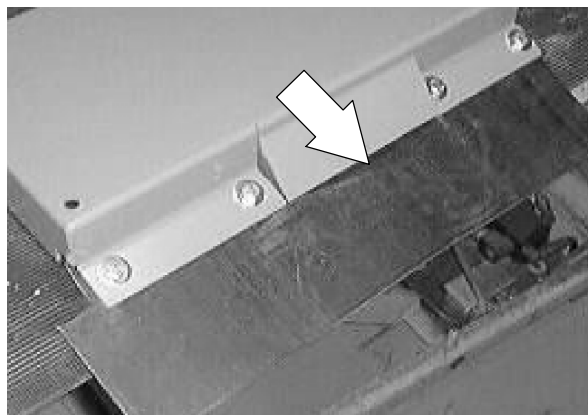

6. Position the two retainers over the new skirt.

7. Thread the skirt retaining bolts through the mount plate, the door skirt, and into the two skirt retainers.

*NOTE: The brush skirts have slotted holes to allow for a ground clearance adjustment. The skirt plate must be mounted on the machine for proper adjustment.*

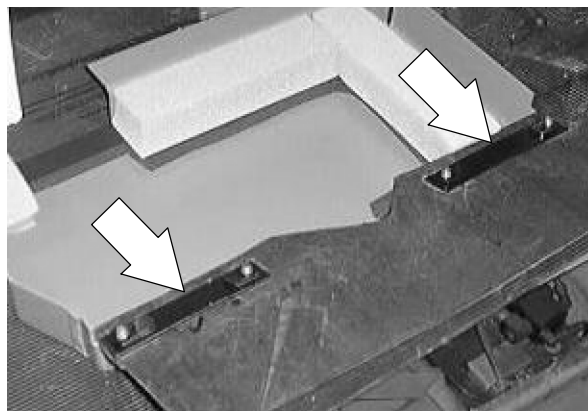

8. Reinstall the skirt mount plate on the machine. Tighten the hex screws to 18 - 24 Nm (15 - 20 ft lb).

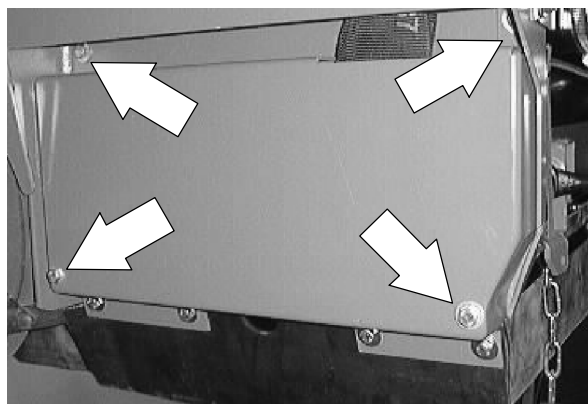

9. Slide the brush door skirt up or down so it will clear the floor by 3–5 mm (0.12 to 0.25 in). Hand tighten the hex screws firmly.

10. Operate the machine and check the new skirts for proper operation.

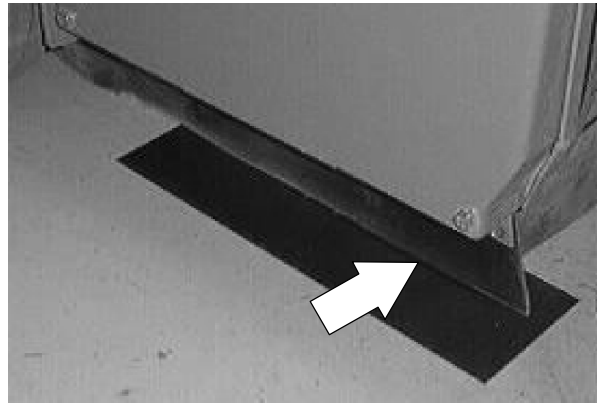

## SWEEPING

### REAR SKIRT AND DEFLECTOR BLADE

The rear skirt and the deflector blade are located on the bottom rear of the main brush compartment. The rear skirt should clear the floor up to 5 mm (0.25 in) in dusty conditions, and touch the floor otherwise.

Check the skirt and blade for wear or damage and adjustment daily.

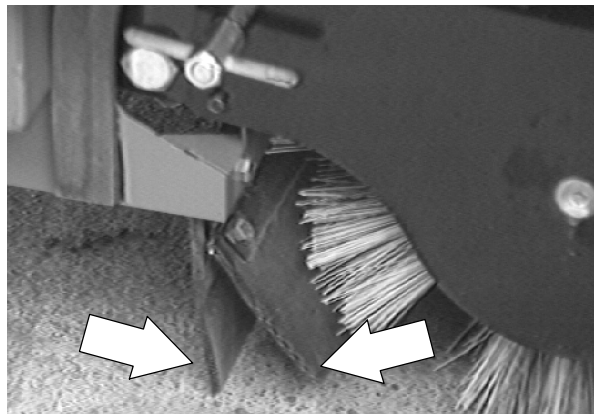

### TO REPLACE AND ADJUST THE REAR SKIRT AND DEFLECTOR BLADE

1. Stop the engine and set the machine parking brake.

**FOR SAFETY: Before Leaving Or Servicing Machine; Stop On Level Surface, Set Parking Brake, Turn Off Machine And Remove Key.**

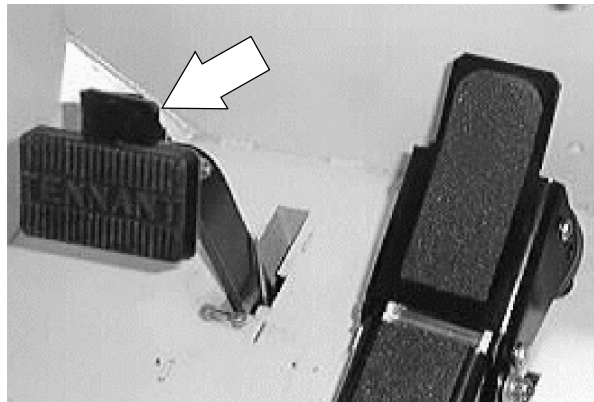

2. Open the right brush door.

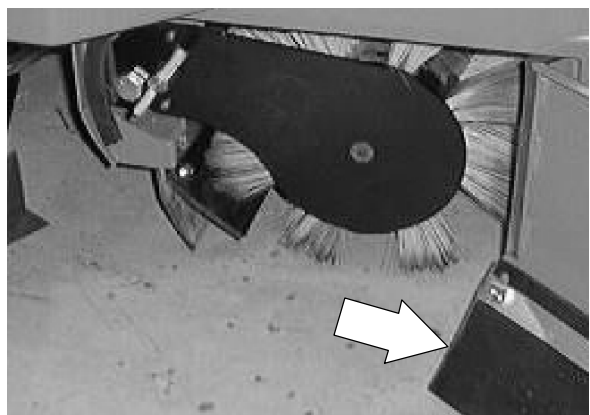

3. Remove the main brush.

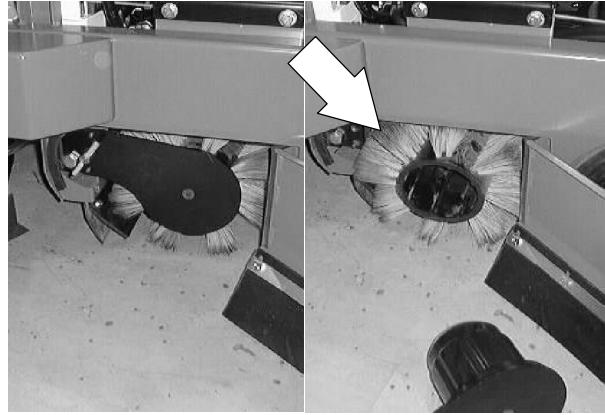

4. Remove the four hex screws holding the skirt assembly to the machine frame. Remove the skirt assembly from the machine.

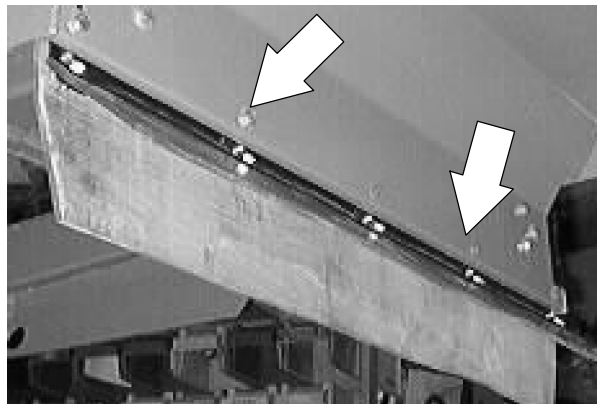

5. Remove the hex screws holding rear skirt and retainer to the assembly. *Remove and discard the rear skirt.*



6. Install the new rear skirt. Reinstall the hardware loosely for now.



## SWEEPING

7. Remove the hex screws holding the deflector blade retaining strip and the deflector blade to the assembly.

*NOTE: Remove and discard the deflector blade.*

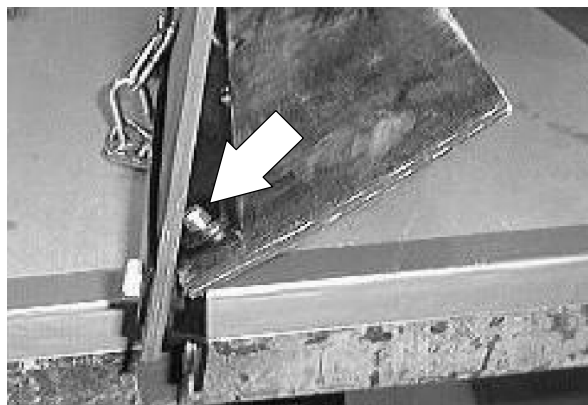

8. Install the new deflector blade and existing retainer onto the skirt assembly bracket. Center the slots of the new skirt. Tighten the skirt mounting bolts to 8-14 Nm (6-10 ft lb).



9. Position the skirt assembly onto the machine. Reinstall the skirt assembly mounting hardware. Tighten to 8-14 Nm (6-10 ft lb).

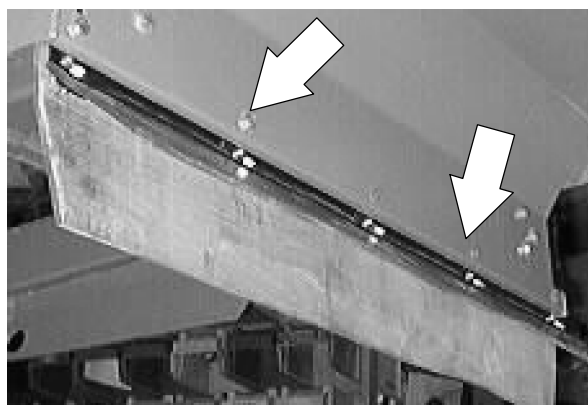

10. Slide the rear floor skirt up or down so that the skirt clears the floor up to a maximum of 5 mm (0.25 in). Tighten the rear skirt mounting bolts to 8-14 Nm (6-10 ft lb).

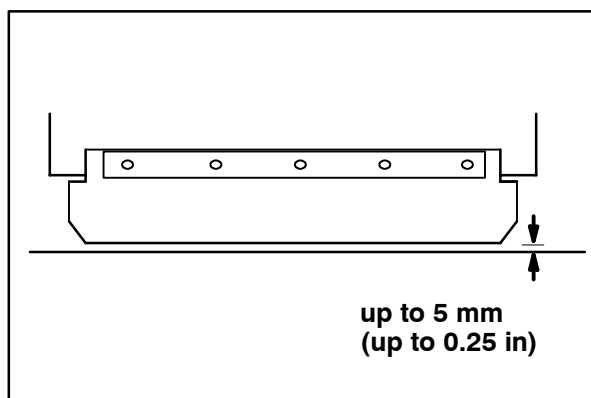



11. Reinstall the main brush.

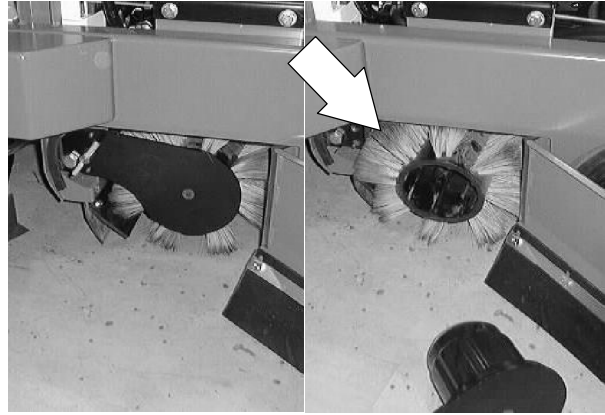

12. Close the right brush door.

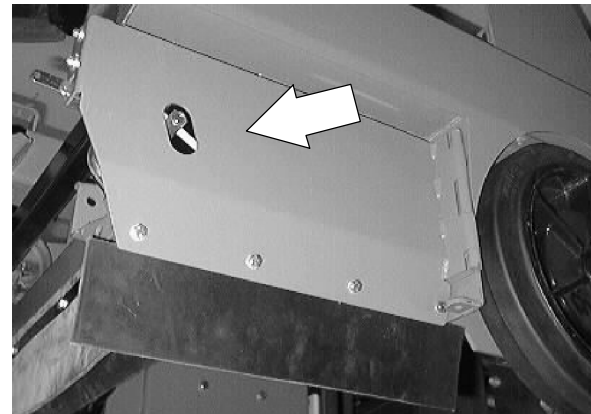

13. Operate the machine and check the new rear skirt and front deflector blade for proper operation.

## SWEEPING

### HOPPER SEALS

The hopper seals are located on the top and side portions of the machine frame that contact the hopper. They seal the main brush compartment. Tighten the seal hardware to 4–5 Nm (3–4 ft lb).

Inspect the seals for wear or damage every 100 hours of operation.

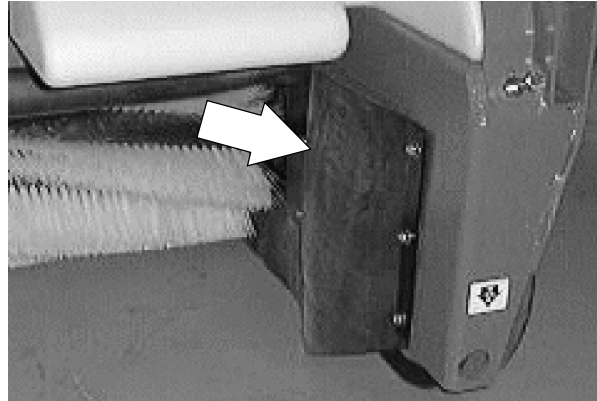

### TO REPLACE HOPPER SEALS

1. Stop the engine and set the machine parking brake.

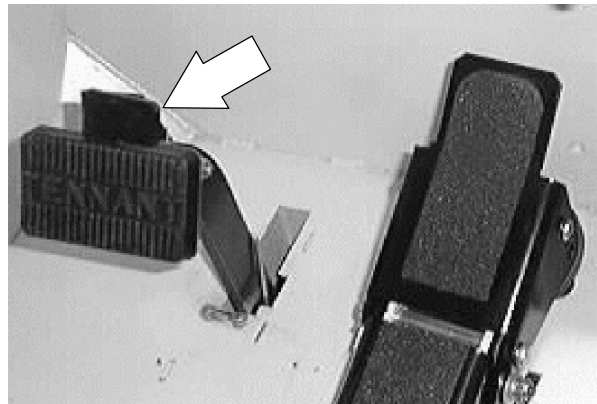

2. Raise hopper and engage hopper support bar.



**WARNING: Raised Hopper May Fall. Engage Hopper Support Bar.**

**FOR SAFETY: Before Leaving Or Servicing Machine; Stop On Level Surface, Set Parking Brake, Turn Off Machine And Remove Key.**

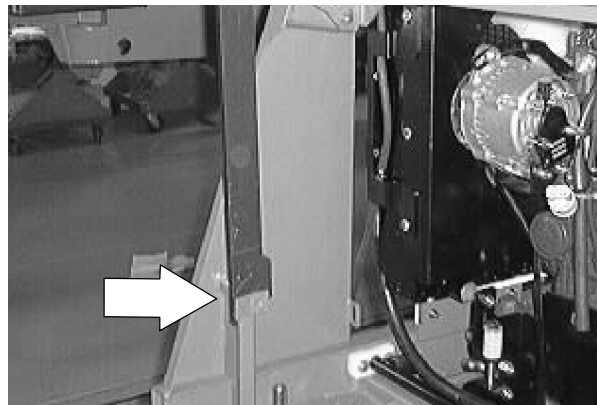

3. Remove the skirt retainers and skirts from each side of the machine.

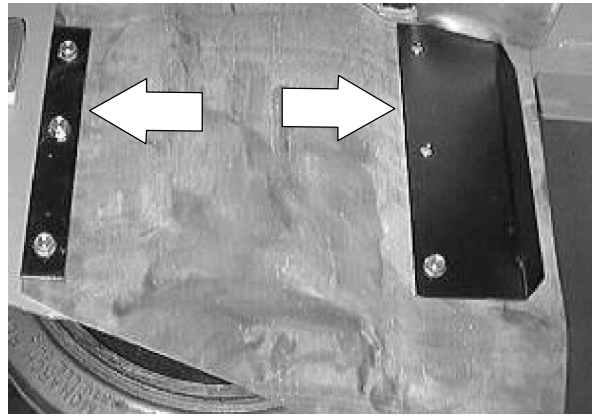

4. Position the new skirts and existing retainers on the insides of the machine frame. Secure with the existing hardware.

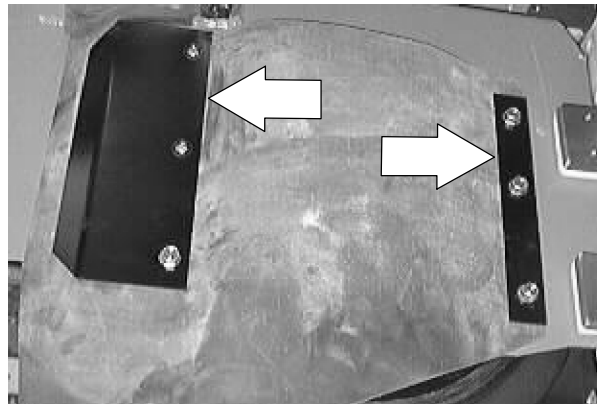

5. Start the engine and lower the hopper.

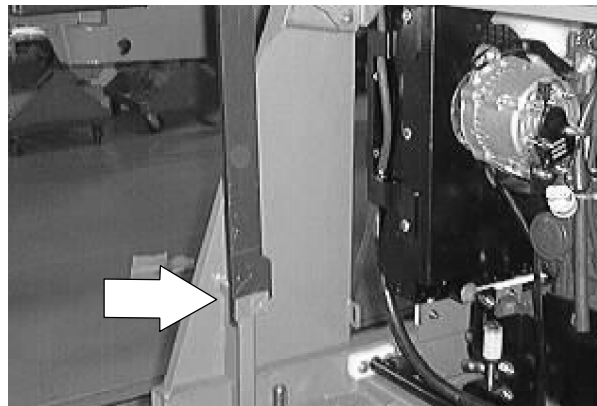

## SWEEPING

### HOPPER DUST SEAL

The hopper dust seal is located under the front of the machine frame in the area of the machine that is contacted when the hopper is in the down position.

Check the seal for wear or damage every 100 hours of operation. You can reach the seal by lifting the hopper and engaging the prop arm.

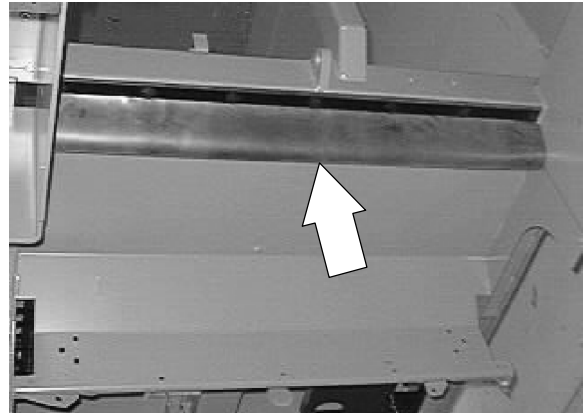

### HOPPER VACUUM FAN SEAL

The hopper vacuum fan seal is mounted on the front the vacuum fan inlet assembly.

Check the seal for wear or damage every 100 hours of operation. You can reach the seal by raising the hopper and engaging the prop arm.

*NOTE: The seal must contact the back of the hopper cover when the hopper cover is in the closed position.*

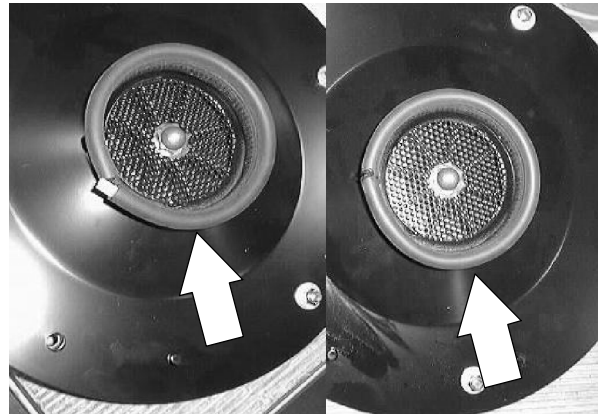

### HOPPER DUMP DOOR SEALS

The hopper door seals are located on each end of the hopper door. They seal the hopper when the hopper door is closed.

Check the seals for wear or damage every 100 hours of operation.

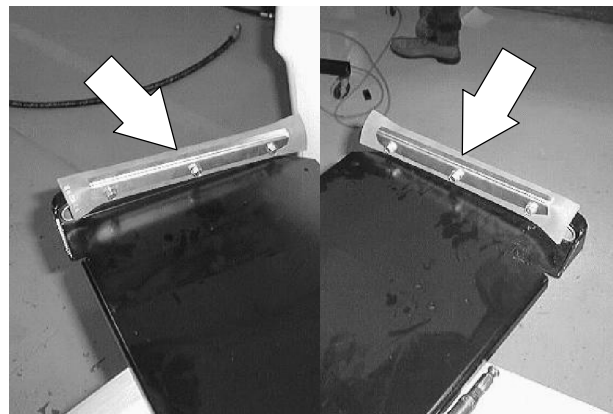

**TO REPLACE HOPPER DUMP DOOR SEALS**

1. Stop the engine and set the machine parking brake.

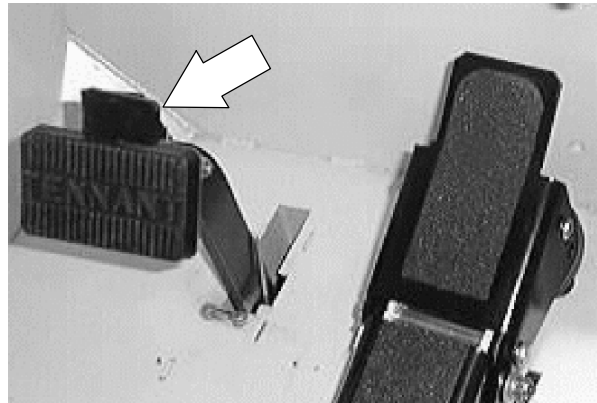

2. Raise hopper and engage hopper support bar.

**⚠ WARNING: Raised Hopper May Fall. Engage Hopper Support Bar.**

**FOR SAFETY: Before Leaving Or Servicing Machine; Stop On Level Surface, Set Parking Brake, Turn Off Machine And Remove Key.**



3. Remove the six hex screws holding the dump door seal, retainer, and sponge cord to dump door. Discard the old seal.

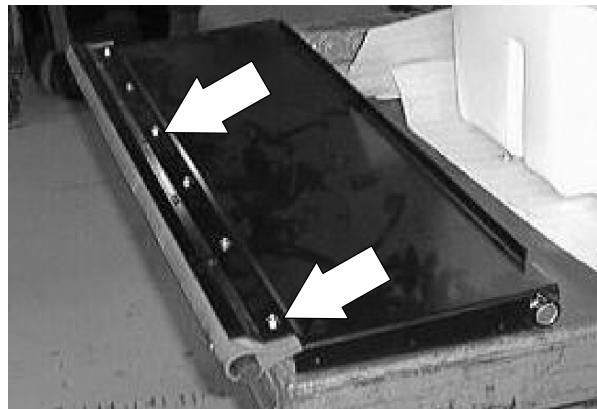

4. Remove the three hex screws holding each side seal to the dump door. Discard the old seals.

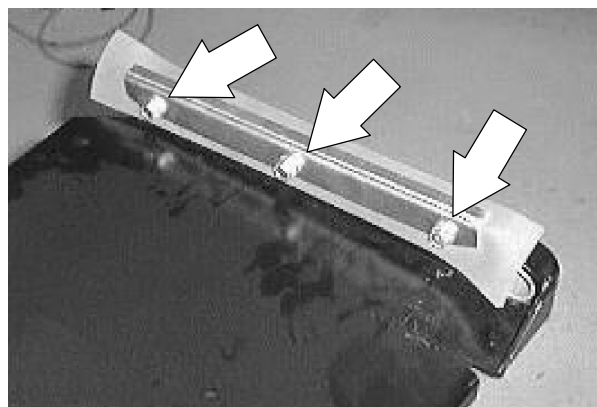

## SWEEPING

5. Align the holes in the new seal with holes on the rear of the dump door and retainer. Reinstall the six hex screws. Tighten to 3.3 - 4.4 Nm (30 - 39 In lb).

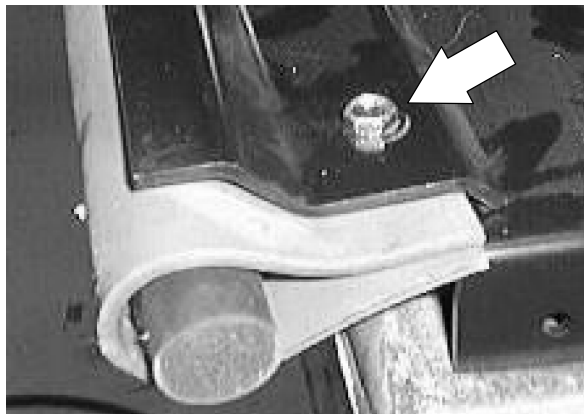

6. Align the holes in the new side seal with holes on the edge of the dump door and retainer. Reinstall the three hex screws. Tighten to 3.3 - 4.4 Nm (30 - 39 In lb). Make sure the seals are lined up with edge of hopper when tightening.

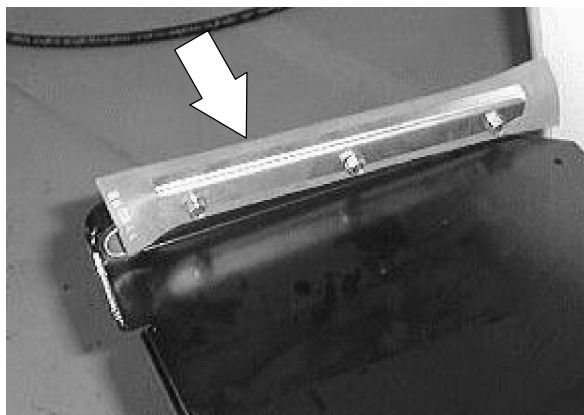

7. Start machine and lower hopper.

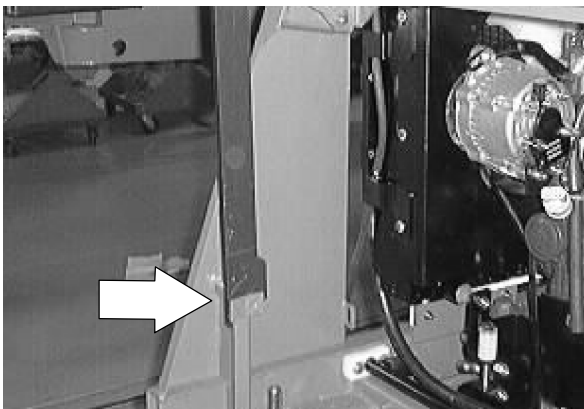

8. Operate the machine and check the dump door for proper operation.

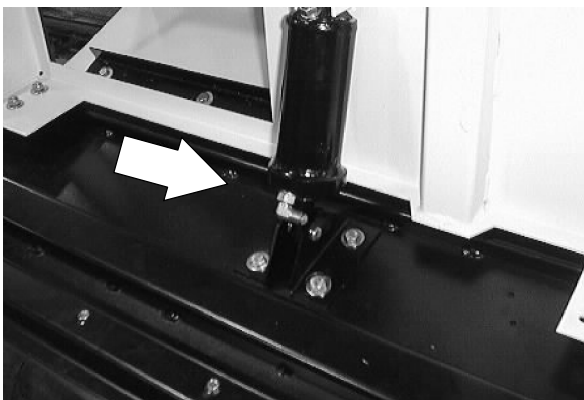

## SWEEPING VACUUM FAN

The sweeping vacuum fan is located in front of the engine. The vacuum fan is used during sweeping to control dusting by pulling air from the main brush area through the hopper and dust filter.

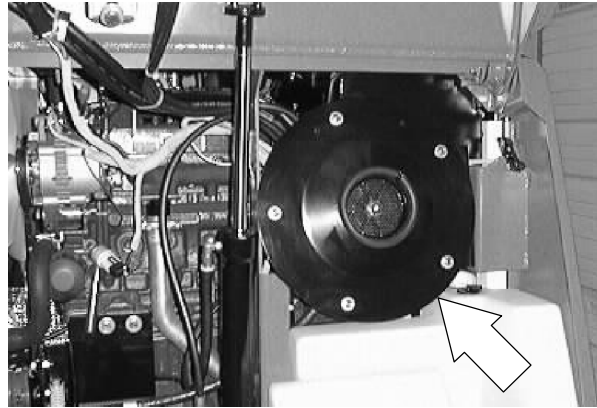

### TO REMOVE SWEEPING VACUUM FAN ASSEMBLY

1. Start the machine and raise the hopper. Engage the prop arm.

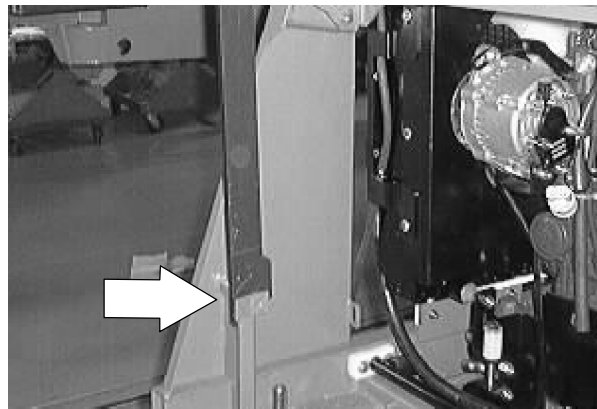

2. Stop the engine and set the machine parking brake. Open the engine cover.

**FOR SAFETY: Before Leaving Or Servicing Machine; Stop On Level Surface, Set Parking Brake, Turn Off Machine And Remove Key.**

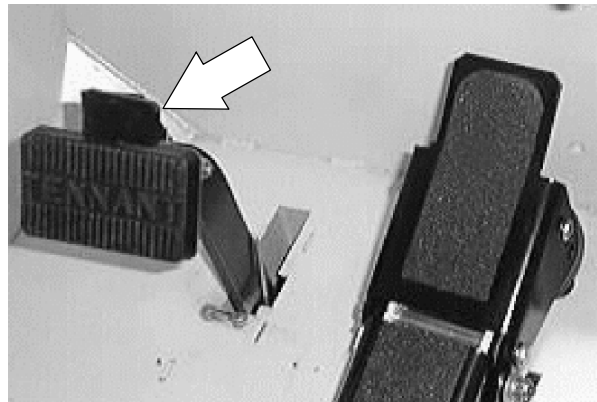

## SWEEPING

3. Disconnect the battery cables and remove the battery from the machine.

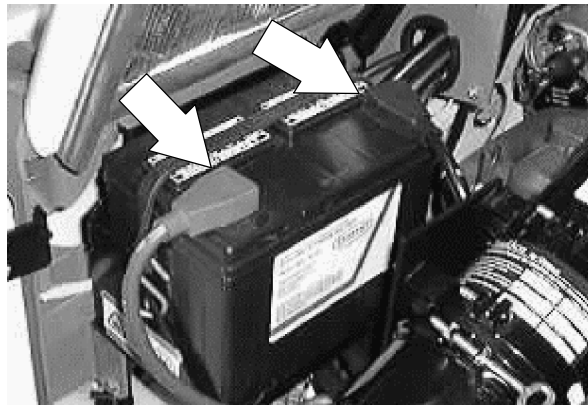

4. Remove the battery tray from the machine frame.

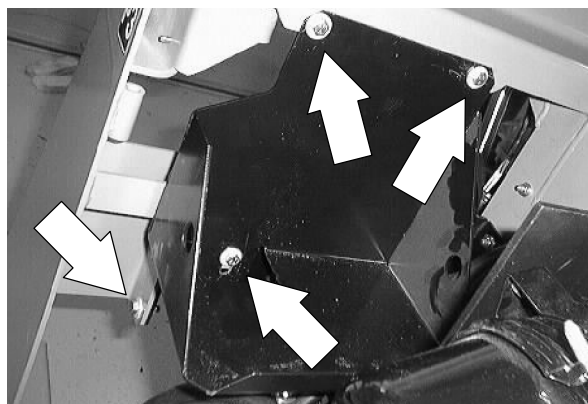

5. Mark, disconnect, and plug the three hydraulic hoses leading to the vacuum fan motor.

*NOTE: Observe hydraulic cleanliness requirements when opening hydraulic lines.*

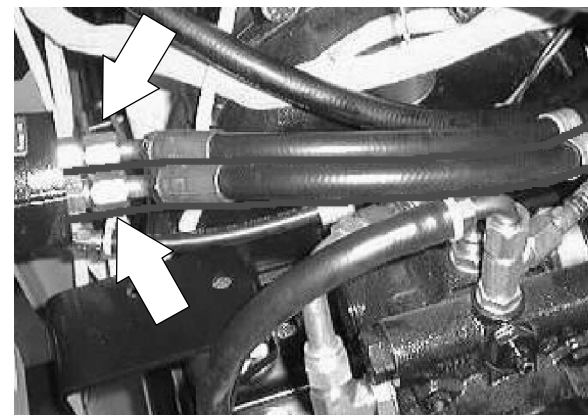

6. Remove the plastic rivets holding the rubber dust shield to the left side of the machine, over the sweeping vacuum fan. Pull the rubber dust shield back to allow access to the vacuum fan mounting hardware.

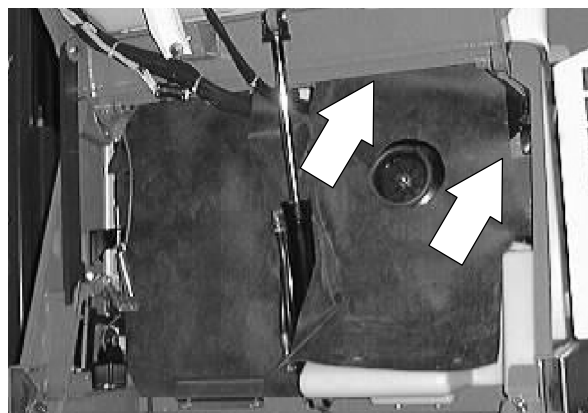



7. Remove the four hex screws holding the front of the sweeping vacuum fan to the two mount brackets.

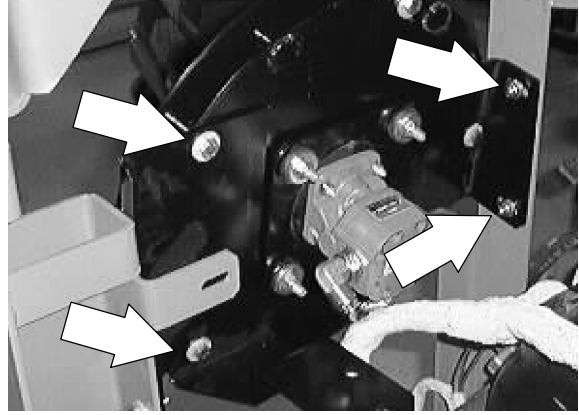

8. Remove the sweeping vacuum fan assembly out the front of the machine.

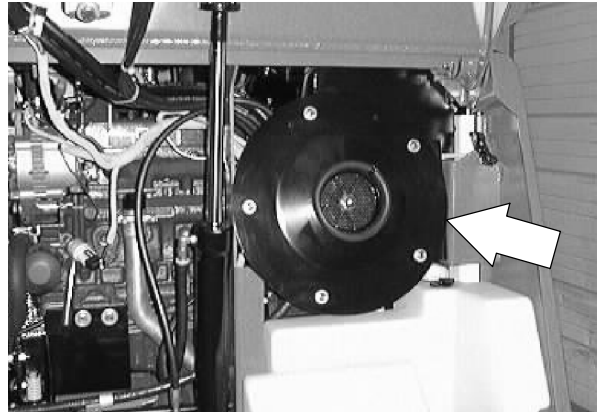

## SWEEPING

### TO INSTALL SWEEPING VACUUM FAN ASSEMBLY

**FOR SAFETY: Before Leaving Or Servicing Machine; Stop On Level Surface, Set Parking Brake, Turn Off Machine And Remove Key.**

1. Position the sweeping vacuum fan assembly into the machine from the front.

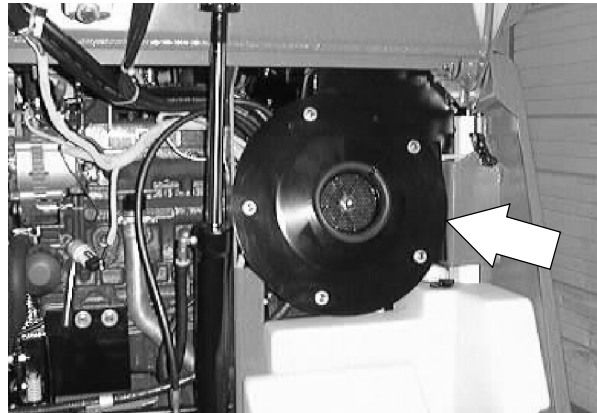

2. Line up the three fan mount holes with the mount brackets on the machine frame.

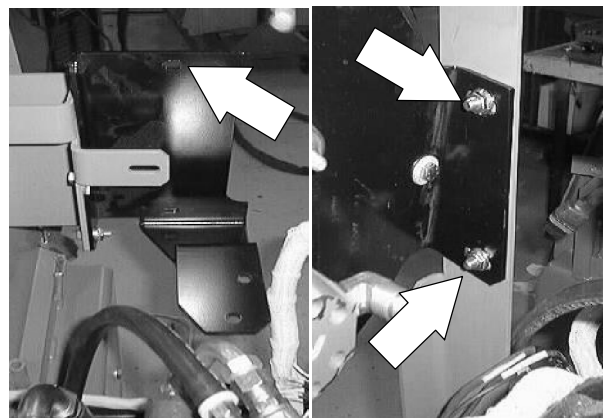

3. Reinstall the hex screws and nuts. Tighten to 18 - 24 Nm (15 - 20 ft lb).

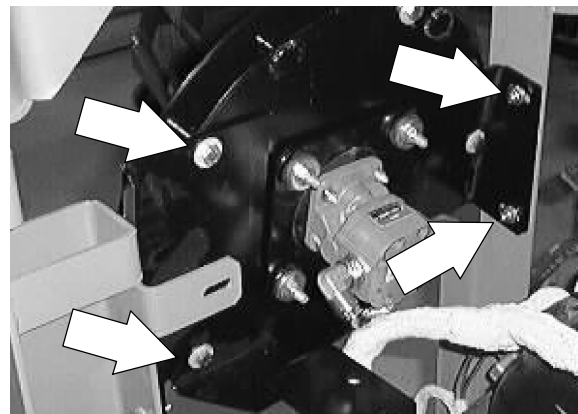

4. Position the rubber dust shield over the vacuum fan assembly. Reinstall the plastic rivets.

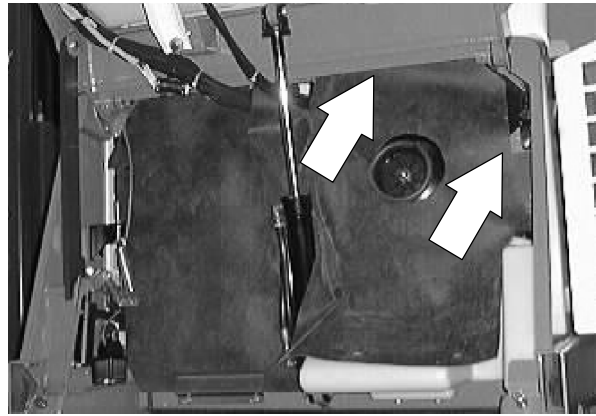

5. Reconnect the three hydraulic hoses. See the schematic in the HYDRAULICS section.

*NOTE: Observe hydraulic cleanliness requirements when opening hydraulic lines.*

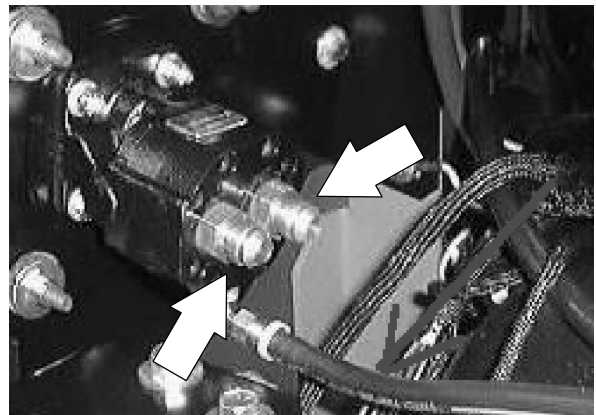

6. Reinstall the battery tray in the machine. Tighten the hardware to 18 - 24 Nm (15 - 20 ft lb).

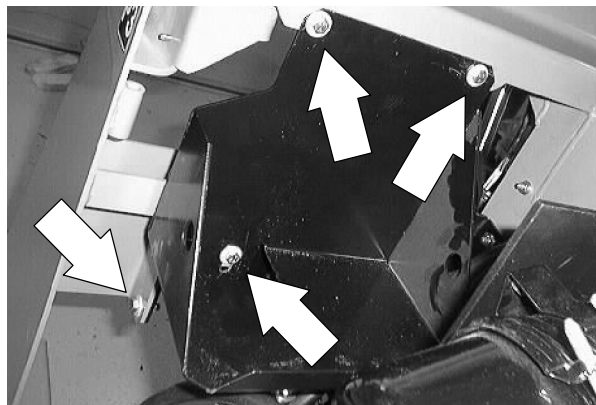

7. Reinstall the battery and reconnect the battery cables.



## SWEEPING

8. Close the engine cover and lower the hopper.

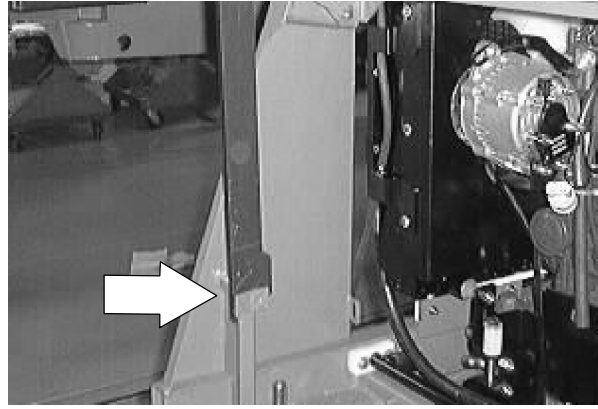

*NOTE: The rubber seal on the front of the sweeping vacuum fan must come in contact with the back of the hopper cover when the cover is in the closed position. Adjust the vacuum fan assembly forward if needed.*

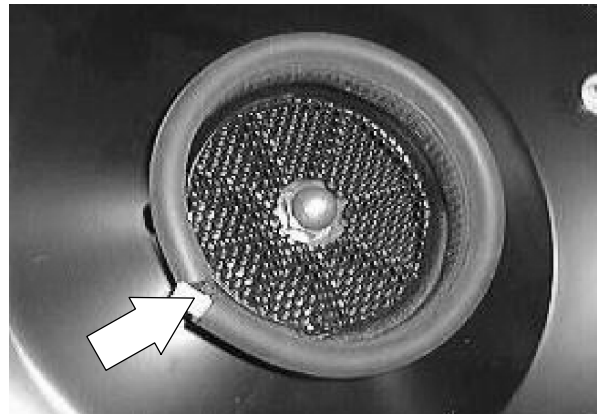

9. Start the machine and operate the sweeping vacuum fan. Check for any leaks and proper operation.

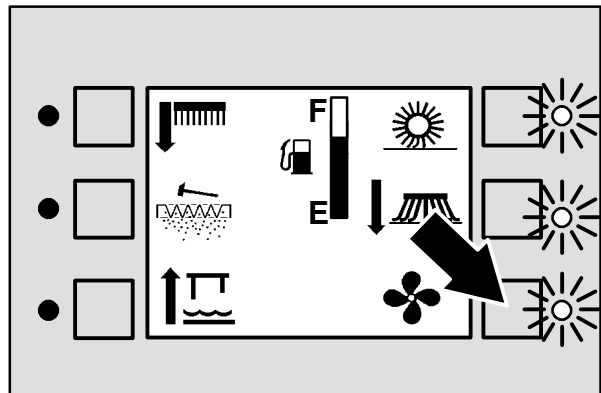

351648

**MACHINE TROUBLESHOOTING**

<b>Problem</b>	<b>Cause</b>	<b>Remedy</b>
Excessive dusting	Brush skirts and dust seals worn, damaged, out of adjustment	Replace or adjust brush skirts or dust seals
	Hopper dust filter clogged	Shake and/or clean or replace dust filter
	Vacuum hose damaged	Replace vacuum hose
	Vacuum fan failure	Contact TENNANT service personnel
	Hopper door partially or completely closed	Open the hopper door
	Thermo Sentry™ tripped	Reset Thermo Sentry™
Poor sweeping performance	Brush bristles worn	Replace brushes
	Main and side brushes not adjusted properly	Adjust main and side brushes
	Debris caught in main brush drive mechanism	Free drive mechanism of debris
	Main brush drive failure	Contact TENNANT service personnel
	Side brush drive failure	Contact TENNANT service personnel
	Hopper full	Empty hopper
	Hopper lip skirts worn or damaged	Replace lip skirts
	Hopper door partially or completely closed	Open the hopper door
	Wrong sweeping brush	Contact TENNANT representative for recommendations



**CONTENTS**

	Page		Page
INTRODUCTION .....	4-3	SQUEEGEES .....	4-50
SOLUTION TANK .....	4-4	SIDE SQUEEGEES .....	4-50
ES SOLUTION TANK .....	4-4	TO REPLACE SIDE SQUEEGEE	
TO DRAIN AND CLEAN ES		BLADES .....	4-50
SOLUTION TANK .....	4-5	TO REPLACE SIDE SQUEEGEE	
TO REMOVE SOLUTION TANK .....	4-7	PIVOT CABLE .....	4-53
TO INSTALL SOLUTION TANK .....	4-10	REAR SQUEEGEE .....	4-57
RECOVERY TANK .....	4-13	TO REPLACE OR ROTATE REAR	
TO DRAIN AND CLEAN RECOVERY		SQUEEGEE BLADES .....	4-57
TANK .....	4-13	TO ADJUST REAR SQUEEGEE	
TO REMOVE RECOVERY TANK .....	4-16	ROLL-OUT .....	4-59
TO INSTALL RECOVERY TANK .....	4-19	TO LEVEL REAR SQUEEGEE .....	4-61
SCRUB HEAD .....	4-22	FINE TUNING REAR SQUEEGEE	
SCRUB HEAD LINKS		LEVELNESS .....	4-64
(Max pro 1000 and Max pro 1200 only) ..	4-22	TO REPLACE REAR SQUEEGEE	
TO REPLACE SCRUB HEAD LINKS ..	4-23	LIFT CABLE .....	4-65
TO REMOVE 2 MOTOR SCRUB		TO REMOVE REAR SQUEEGEE	
HEAD (stationary) .....	4-25	FRAME .....	4-67
TO INSTALL 2 MOTOR SCRUB		TO INSTALL REAR SQUEEGEE	
HEAD (stationary) .....	4-28	FRAME .....	4-69
TO REMOVE 2 MOTOR SCRUB		SCRUBBER VACUUM FAN .....	4-72
HEAD (with side-shift option) ....	4-31	TO REMOVE SCRUBBER VACUUM	
TO INSTALL 2 MOTOR SCRUB		FAN ASSEMBLY .....	4-72
HEAD (with edge scrub option) ...	4-35	TO INSTALL SCRUBBER VACUUM	
TO REMOVE 3 MOTOR SCRUB		FAN ASSEMBLY .....	4-75
HEAD (Max pro 1200) .....	4-39	MACHINE SCRUBBING	
TO INSTALL 3 MOTOR SCRUB		TROUBLESHOOTING .....	4-78
HEAD (Max pro 1200) (retractable)	4-43		
SCRUB HEAD SKIRTS .....	4-47		
TO REPLACE SCRUB HEAD			
SKIRTS .....	4-47		
SCRUB BRUSHES .....	4-48		
TO REPLACE SCRUB BRUSHES ...	4-48		
SOLUTION VALVE .....	4-49		





---

**INTRODUCTION**

---

When scrubbing, the water flows from the solution tank, through the solution valve, and down to the scrub brushes. The brushes scrub the floor. As the machine moves forward the rear squeegee wipes the dirty solution off the floor, which is then picked up and drawn into the recovery tank by the vacuum fan.

# SCRUBBING

## SOLUTION TANK

The solution tank supplies the scrub brushes with a water and detergent solution. The solution tank is located on the right hand side of machine, beside the recovery tank.

Access to the solution tank is through the opening at the top of the tank, reached by lifting up the cover.

The solution tank requires no regular maintenance. If detergent cakes on the bottom of the tank, remove the deposits with a strong blast of warm water. Do not use water hotter than 130° F (54° C) or use steam to clean the tank because damage may occur. A tank drain cap has been provided to allow the tank to be drained for cleaning.



## ES™ SOLUTION TANK

The ES™ machine solution tanks supply the scrub brushes with a water and cleaning solution mixture. The tanks also store water picked up by the machine squeegees and the vacuum fan.

Access to the ES™ solution tanks is through the opening at the top of the tanks, reached by lifting up the tank cover.

The ES™ solution tank should be drained and cleaned after every work shift.

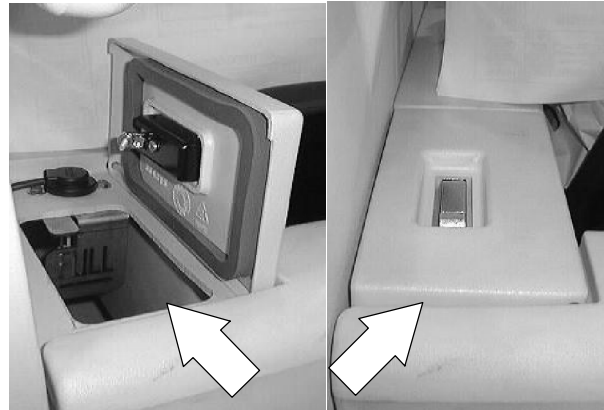

**TO DRAIN AND CLEAN ES SOLUTION TANK**

1. Make sure the solution tank is empty.



2. Press the scrub brush switch to raise the scrub head and stop the brushes.

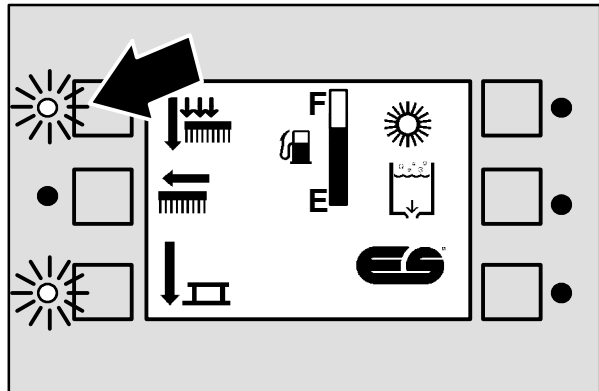

3. Press the squeegee and vacuum fan switch to raise the rear squeegee and stop the vacuum fan.

4. Stop the machine next to a floor drain.

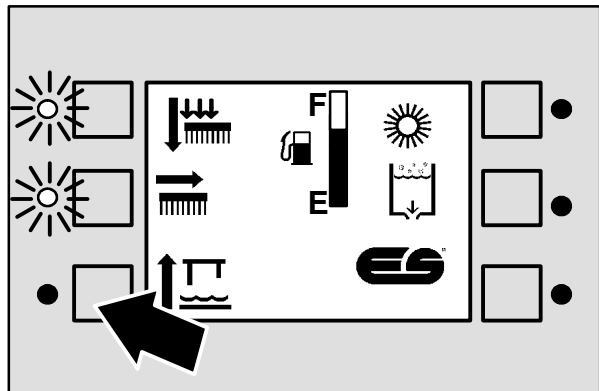

5. Turn off the machine and set the machine parking brake.

**FOR SAFETY: Before Leaving Or Servicing Machine; Stop On Level Surface, Set Parking Brake, Turn Off Machine And Remove Key.**

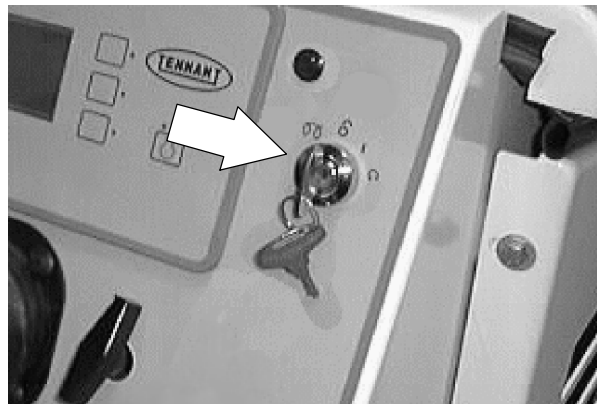

## SCRUBBING

6. Unscrew the drain cap from the solution tank drain. Drain the solution.

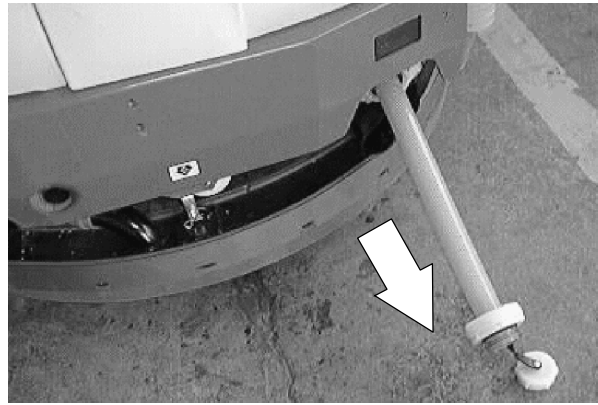

7. Open the tank cover.

8. Spray the inside of the solution tank with clean water. Do not use water hotter than 130° F (54° C) or use steam to clean the tank because damage may occur.



9. Lower the tank cover.

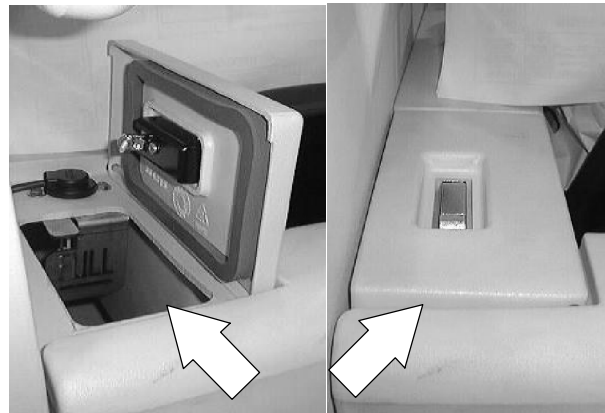

10. Replace the drain cap.

11. For machines with the positive drain cap option, close the drain valve. Remove the drain hose and attach the dust cap.

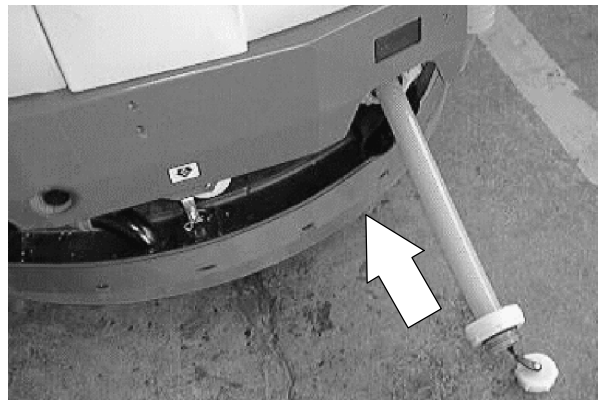

## TO REMOVE SOLUTION TANK

1. Make sure the solution tank is empty.

**FOR SAFETY: Before Leaving Or Servicing Machine; Stop On Level Surface, Set Parking Brake.**

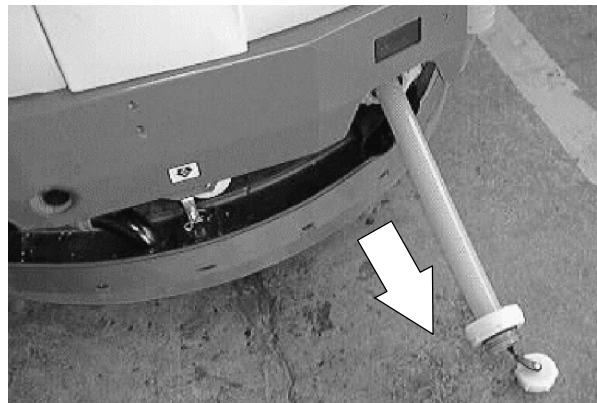

2. Open the recovery tank cover.

*NOTE: If the machine is equipped with the heavy duty bumper option, the rear tank bumper must be removed before the tanks can be removed.*



3. Remove the two nuts and the metal plate from the inside wall of the recovery tank.

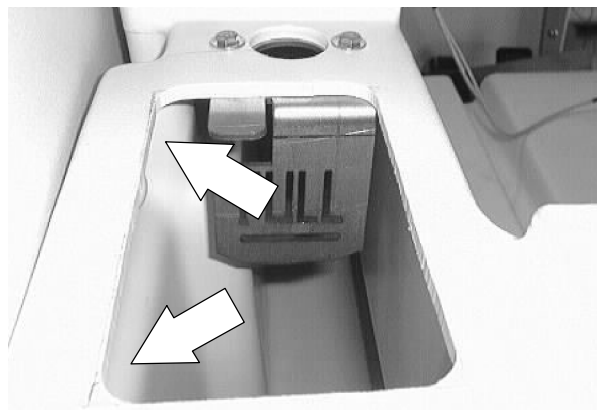

4. ES™ MACHINE: Open the engine cover and locate the water inlet line on the front corner of the solution tank. Loosen the clamp and pull the line off the fitting.

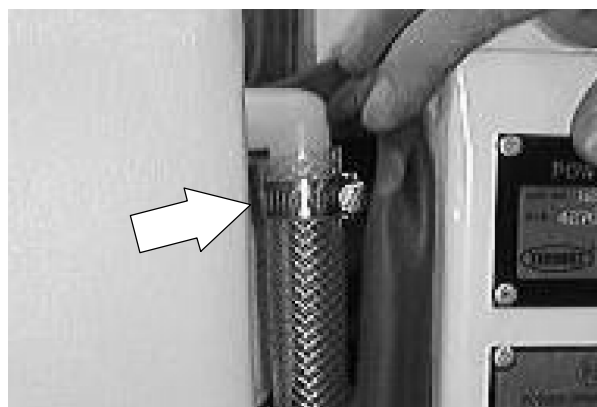

## SCRUBBING

5. Go under the machine at the back, right corner. Locate the water drain line on the right side of the solution tank. Loosen the clamp and pull the line off the fitting.

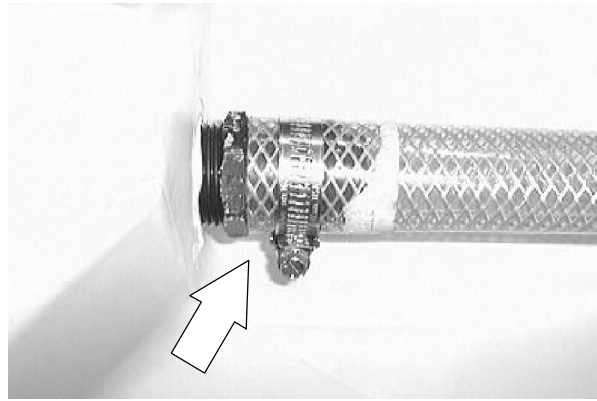

6. Remove the two hex screws and flat washers holding the bottom of the solution tank to the machine frame.



7. Pull the solution tank away from the recovery tank.



8. ES™ MACHINE: Disconnect the water level sensor from the main harness in the area of the solution tank fill cover.

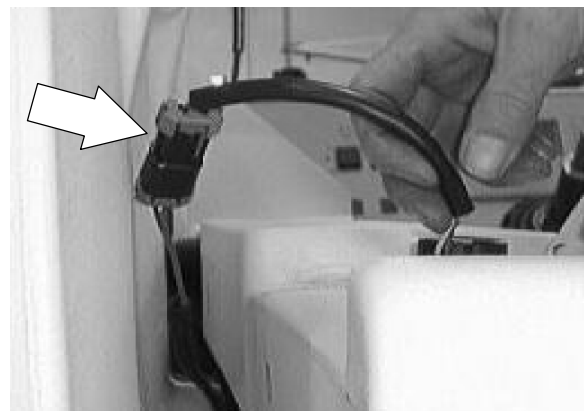

9. Disconnect the water line at the top, front corner of the tank.

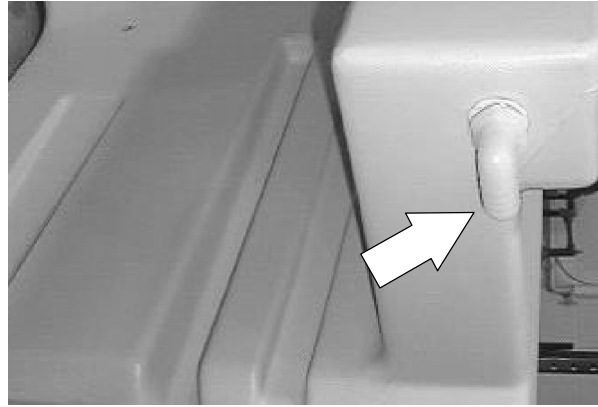

10. Pull the solution tank out of the machine.



## SCRUBBING

### TO INSTALL SOLUTION TANK

**FOR SAFETY: Before Leaving Or Servicing Machine; Stop On Level Surface, Set Parking Brake.**

1. Position the solution tank in the machine, next to the recovery tank.



*NOTE: Make sure the two studs are installed into the inserts on the side of the solution tank that comes in contact with the recovery tank.*

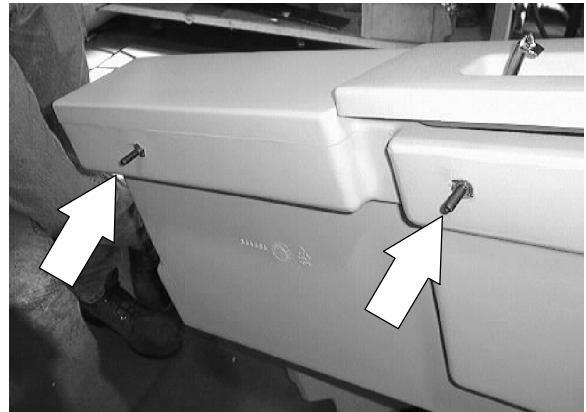

2. ES™ MACHINE: Connect the water level sensor to the main electrical harness in the area of the solution tank fill cover.





3. Push the solution tank up against the recovery tank.



4. Line up the two holes in the recovery tank with the two studs on the side of the solution tank. Push the studs through the holes.
5. Install the metal plate, washers and nuts onto the tank studs. Leave loose for now.



6. Go under the machine at the back, right corner. Locate the water drain line and install it on the plastic fitting on the lower, right side of the solution tank. Hand tighten the clamp.
7. Align the threaded inserts on the bottom of the tank with the two mount holes in the machine frame. Install the hardware and tighten to 18 - 24 Nm (15 - 20 ft lb).
8. Go back inside the top of the recovery tank and tighten the two nuts to 18 - 24 Nm (15 - 20 ft lb).



9. ES™ MACHINE: Open the engine cover and locate the water inlet fitting on the front corner of the solution tank.

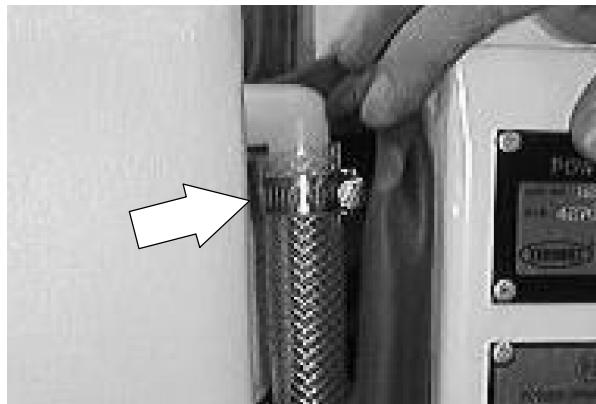

## SCRUBBING

10. ES™ MACHINE: Locate the ES™ pump solution line and install on the fitting. Hand tighten the clamp. Close the engine cover.

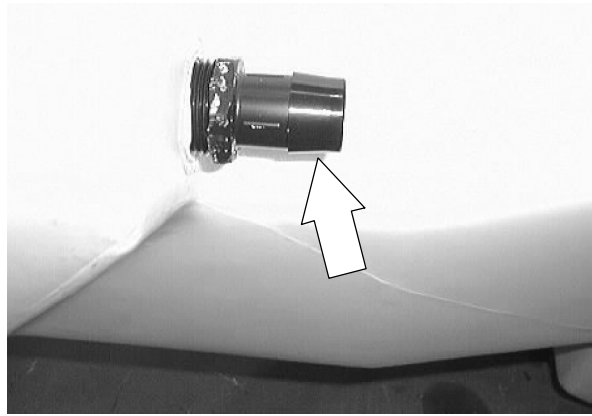

11. Fill the solution tank and check for any leaks.

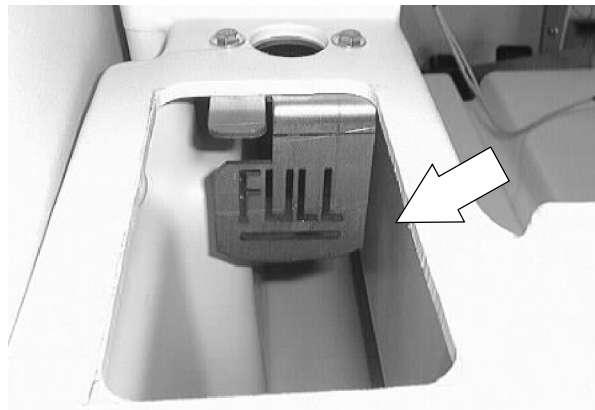

**RECOVERY TANK**

The recovery tank stores water solution picked up by the machine squeegees and the vacuum fan. The recovery tank is located on the left side of the machine, beside the solution tank.

The recovery tank should be drained and cleaned after the solution tank is empty and whenever the float stops the vacuum fan or the recovery tank full lamp lights.

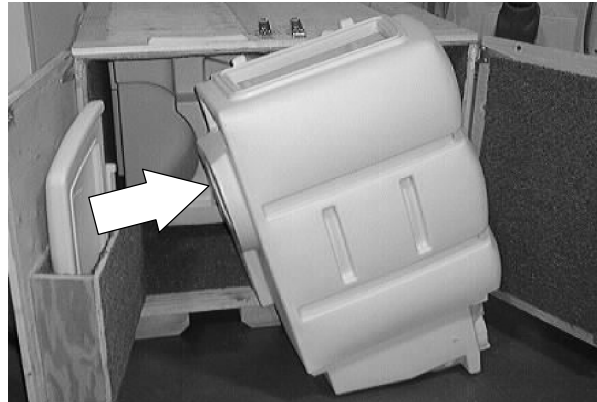

**TO DRAIN AND CLEAN RECOVERY TANK**

1. Make sure the recovery tank is empty.



2. Press the scrub brush switch to raise the scrub head and stop the brushes.

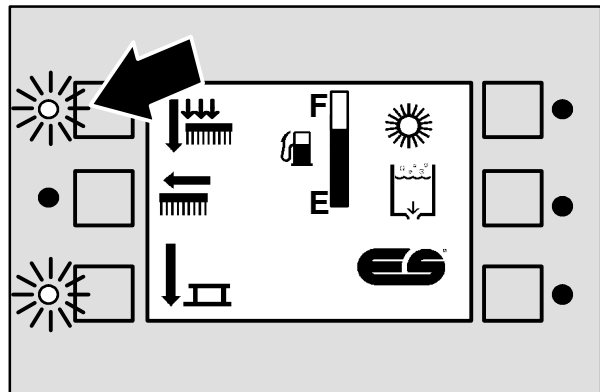

## SCRUBBING

3. Press the squeegee and vacuum fan switch to raise the rear squeegee and stop the vacuum fan.
4. Stop the machine next to a floor drain.

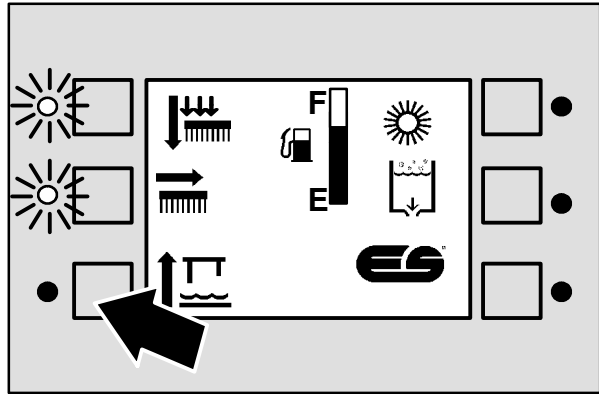

5. Turn off the machine and set the machine parking brake.

**FOR SAFETY: Before Leaving Or Servicing Machine; Stop On Level Surface, Set Parking Brake, Turn Off Machine And Remove Key.**

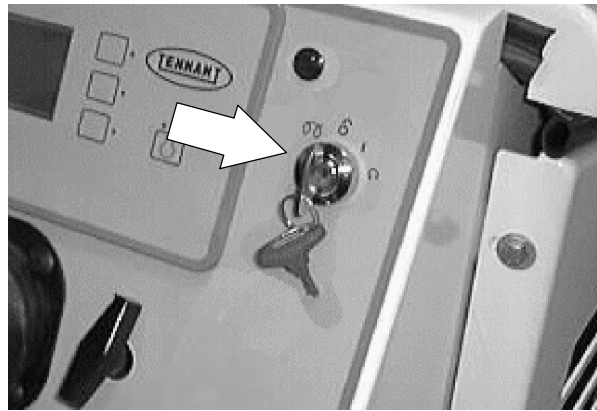

6. To drain the recovery tank, unscrew the drain hose cap from the access cap of the recovery tank drain.
7. Pull out and place the drain hoses next to the floor drain. Remove the drain cap from the hose. Stand back, the solution rushes out of the drain hose.
8. For machines with the positive drain cap option, remove the dust cap. Connect the drain hose and open the drain valve.

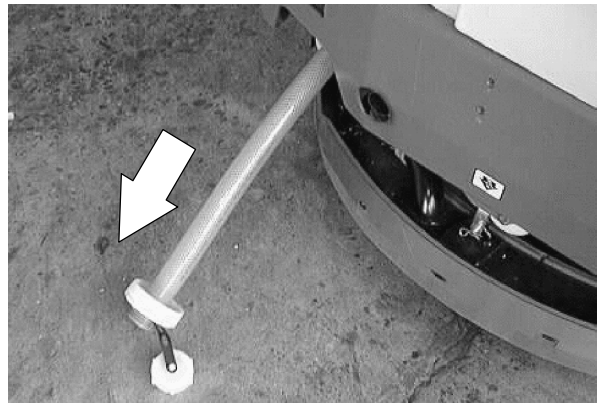

9. Open the tank cover.

10. Spray the inside of the recovery tank with clean water. Do not use water hotter than 130° F (54° C) or use steam to clean the tank because damage may occur.

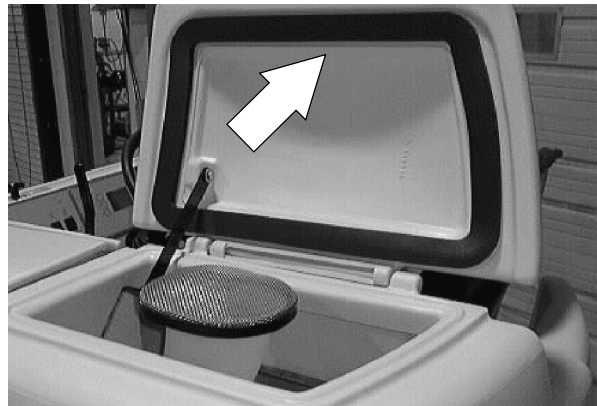

11. Remove the vacuum outlet screen from the tank horn. Clean the vacuum outlet screen and place it back on the horn.

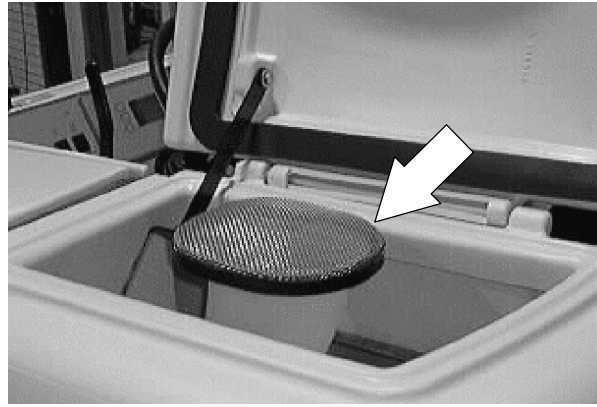

12. Lower the tank cover.

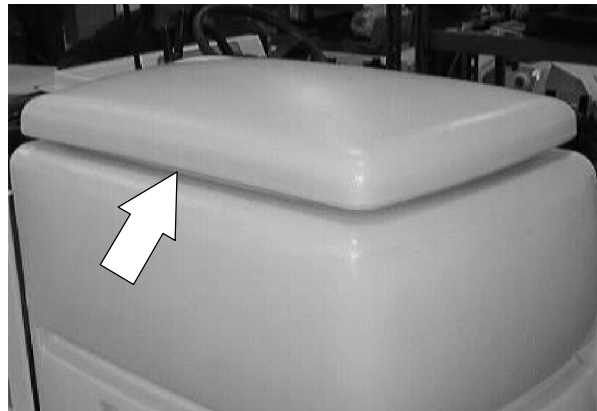

13. Replace the drain hoses and drain cap.

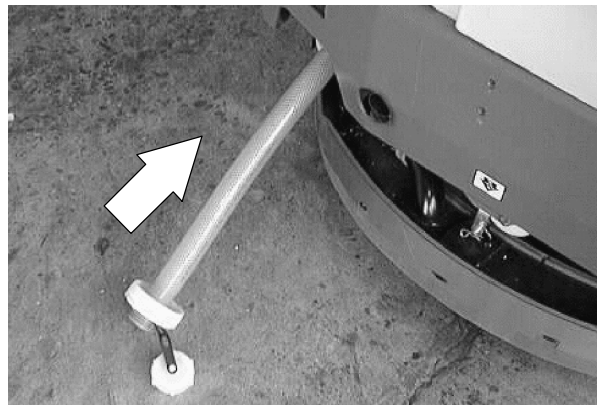

14. For machines with the positive drain cap option, close the drain valve. Remove the drain hose and attach the dust cap.

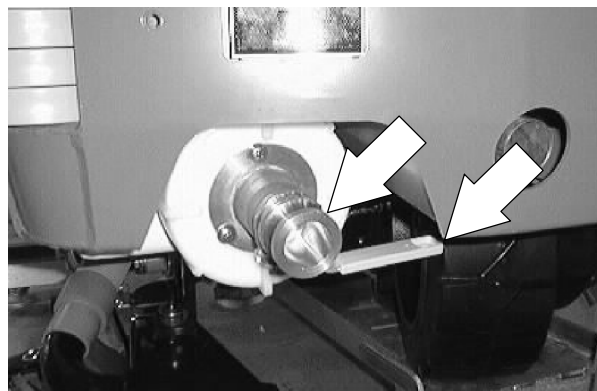

## SCRUBBING

### TO REMOVE RECOVERY TANK

1. Make sure the recovery tank is empty.

**FOR SAFETY: Before Leaving Or Servicing Machine; Stop On Level Surface, Set Parking Brake.**

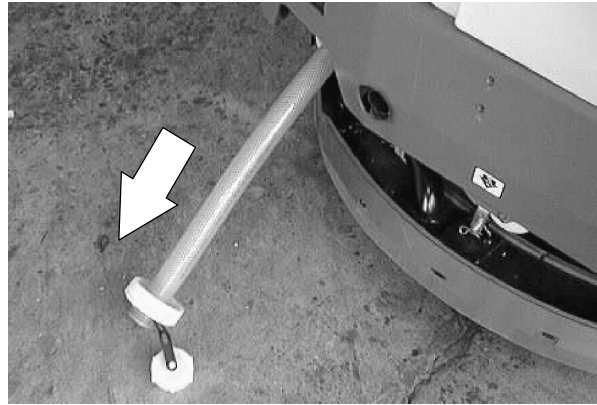

2. Open the recovery tank cover.

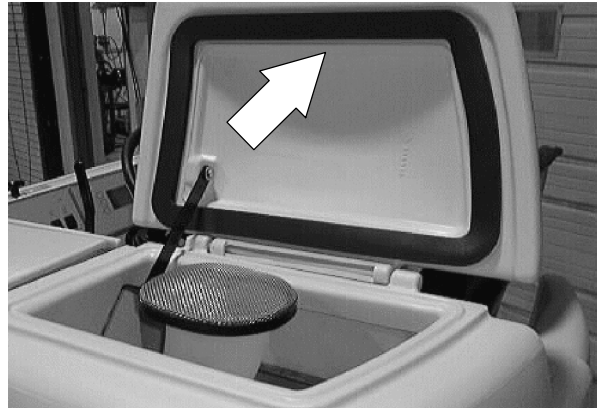

*NOTE: If the machine is equipped with the heavy duty bumper option, the rear tank bumper must be removed before the tanks can be removed.*

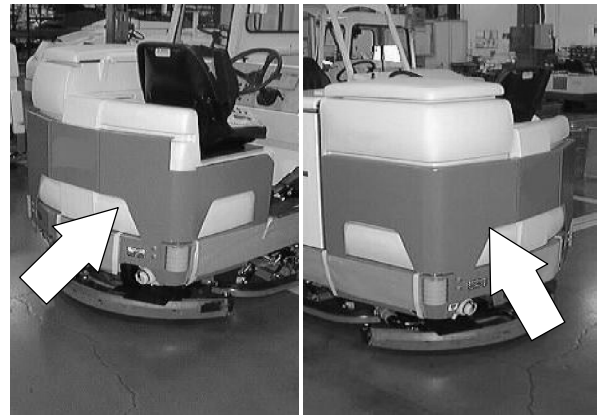

3. Remove the two nuts and the metal plate from the inside wall of the recovery tank.

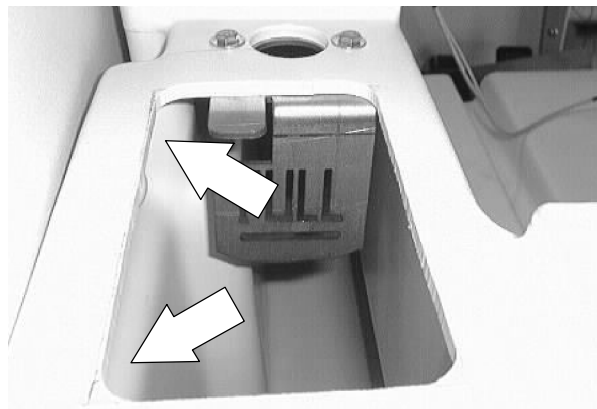

4. Open the engine cover.

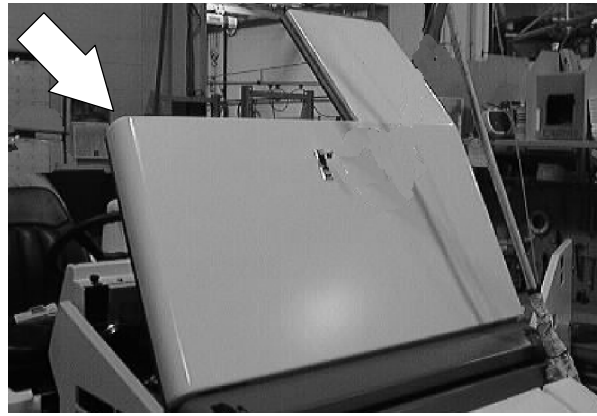

5. Mark, disconnect, and plug the hydraulic hoses leading to the scrubbing vacuum fan motor.

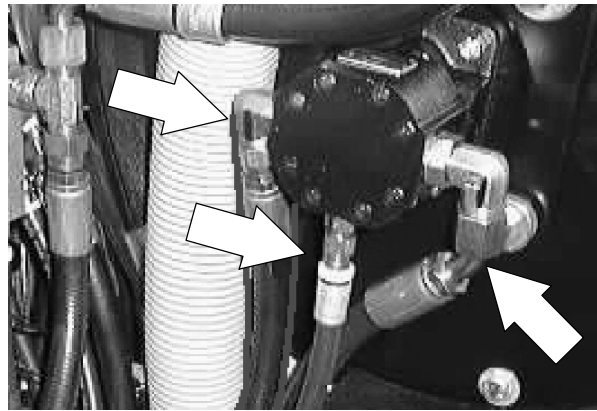

6. Disconnect the float switch located at the front of the recovery tank. There are two switches on a machine equipped with ES™.

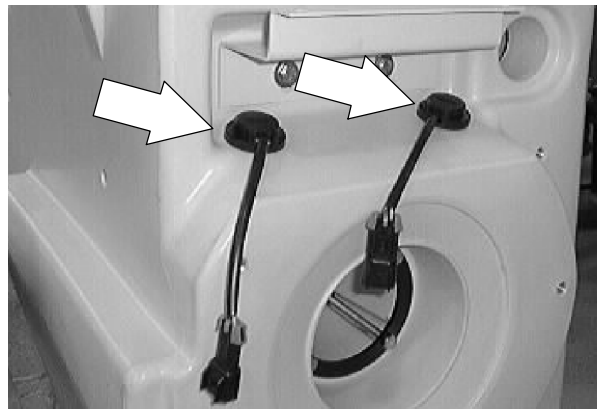

7. Go under the machine at the left, rear corner. Locate the two hex screws and flat washers holding the bottom of the solution tank to the machine frame. Remove the screws.



## SCRUBBING

8. ES™ MACHINE: locate the solution line and bulkhead fitting on the lower side of the recovery tank. Loosen the clamp and remove the solution hose.

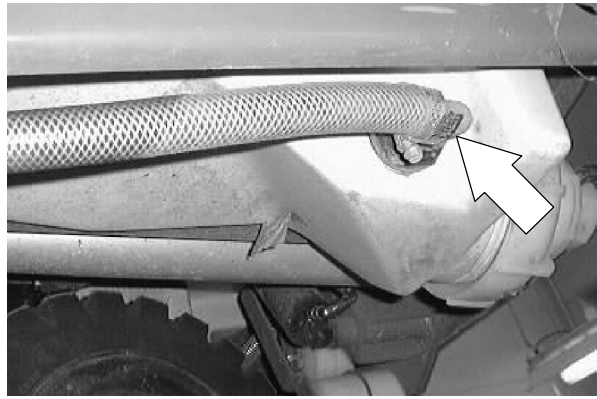

9. Pull the recovery tank away from the solution tank.



10. Pull the recovery tank out of the machine.





## TO INSTALL RECOVERY TANK

**FOR SAFETY: Before Leaving Or Servicing Machine; Stop On Level Surface, Set Parking Brake.**

1. Position the recovery tank in the machine, next to the solution tank.



*NOTE: Make sure the two studs are installed into the inserts on the side of the solution tank that comes in contact with the recovery tank.*



2. Push the recovery tank up against the solution tank.
3. Line up the two holes in the recovery tank with the two studs on the side of the solution tank. Push the studs through the holes.
4. Install the metal plate, washers and nuts on the tank studs. Leave loose for now.

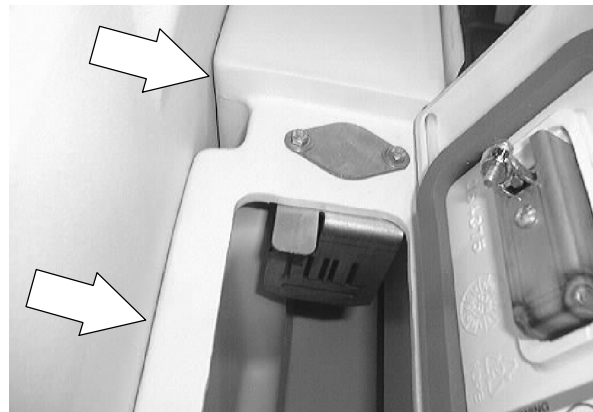

## SCRUBBING

5. Go under the machine at the back, left corner.
6. Align the threaded inserts on the bottom of the tank with the two mount holes in the machine frame. Install the hardware and tighten to 18 - 24 Nm (15 - 20 ft lb).



7. ES™ MACHINE: Place the ES™ solution line onto the bulkhead fitting on the lower side of the recovery tank. Tighten the clamp.

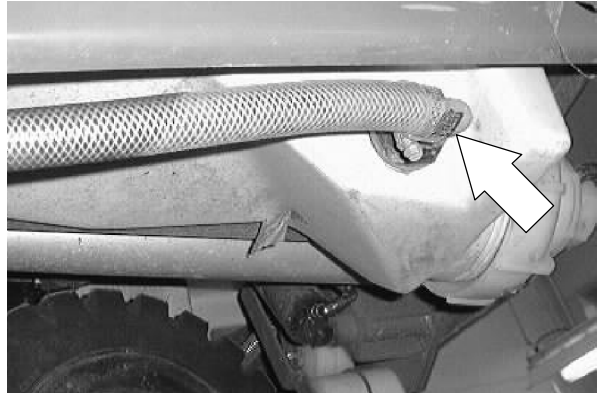

8. Go back inside the top of the recovery tank and tighten the two nuts to 18 - 24 Nm (15 - 20 ft lb).

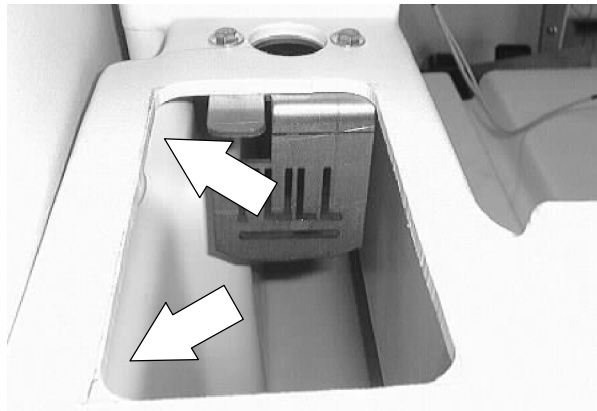

9. Reconnect the float switch at the front of the recovery tank. There are two switches on the ES™ machines.

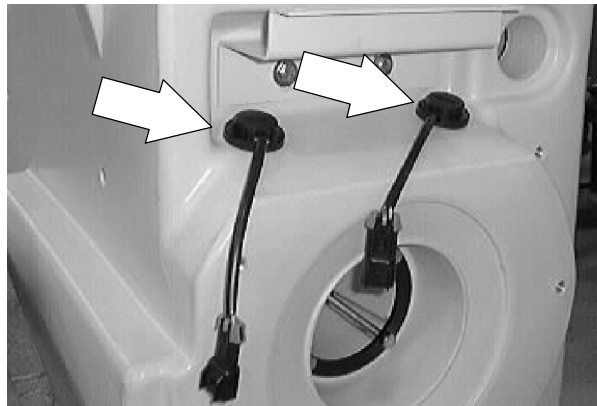

10. Reconnect the hydraulic hoses to the scrubbing vacuum fan. See schematic in the HYDRAULIC section.

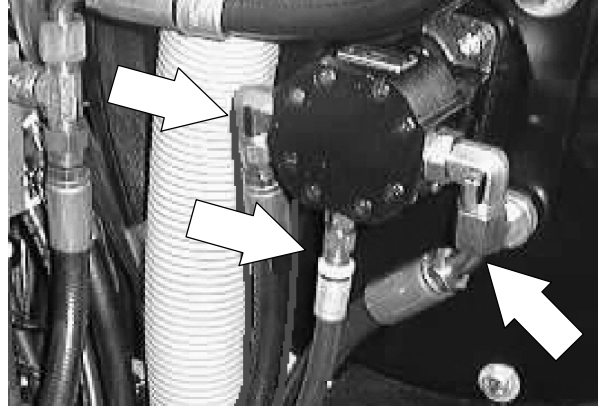

11. Close the engine cover and tank cover.

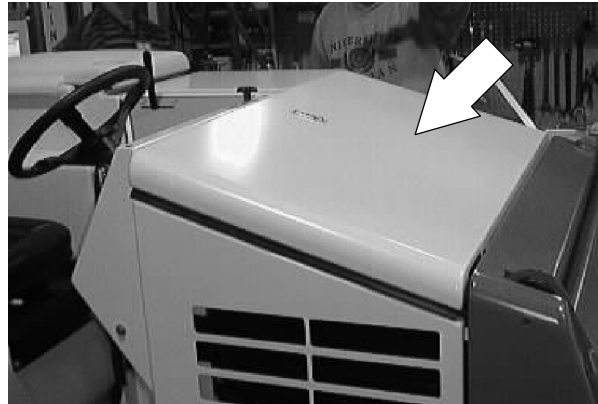

12. Operate the machine and check for any leaks and proper operation of the float switches.

# SCRUBBING

## SCRUB HEAD

The scrub head houses disc type scrub brushes and their drive mechanisms. The scrub head is factory adjusted and the measurement should not be changed unless scrub head parts are damaged or are replaced.

The machine can be equipped with either a two or a three brush motor scrub head and a side shift option. The scrub head floor skirts control water spray from the brushes.

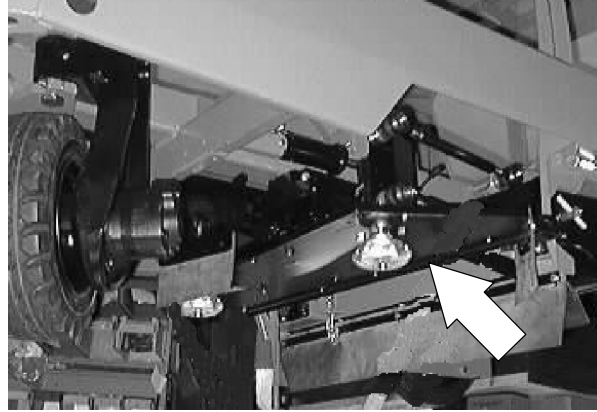

## SCRUB HEAD LINKS (Max pro 1000 and Max pro 1200 only)

The scrub head links attach the scrub head frame to the machine frame. The two motor scrub head has four links.

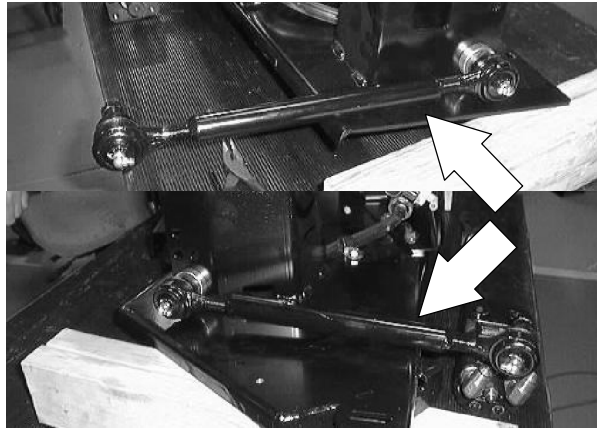

The three motor scrub head has two links. The links allow the scrub head to follow the contour of the floor. The scrub head links have (two or four) pivot points on each side of the machine. Lubricate the pivot points with a grease gun containing Lubriplate EMB grease (TENNANT Part No. 01433-1) after every 200 hours of operation.

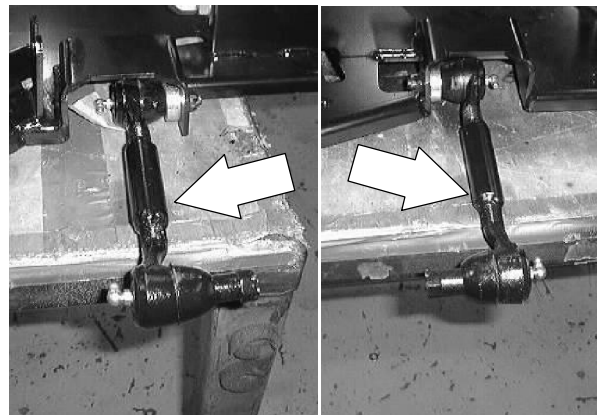

## TO REPLACE SCRUB HEAD LINKS (Max pro 1000 and Max pro 1200 only)

1. Stop the machine and lower the scrub head.

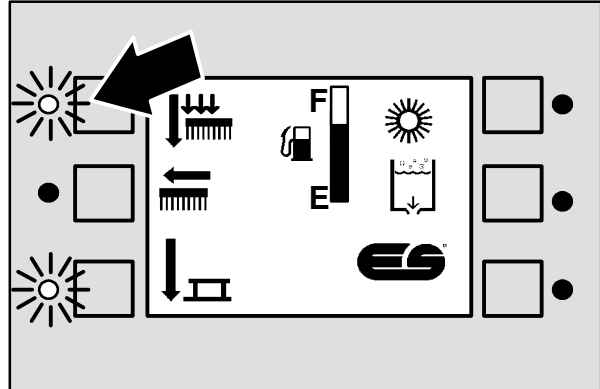

2. Turn off the machine and set the machine parking brake.

**FOR SAFETY: Before Leaving Or Servicing Machine; Stop On Level Surface, Set Parking Brake, Turn Off Machine And Remove Key.**

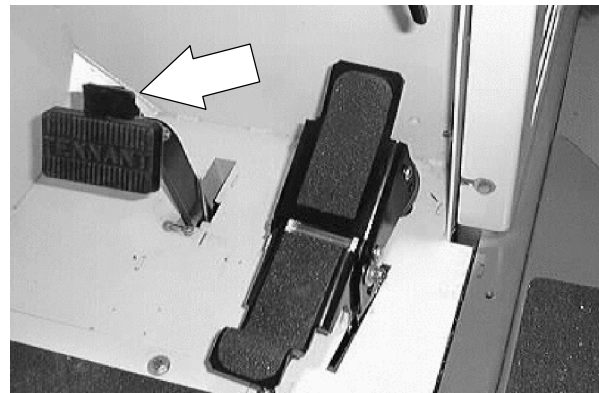

3. Remove the cotter pins from the castle nuts holding the scrub head link to the front of the scrub head and the machine frame.

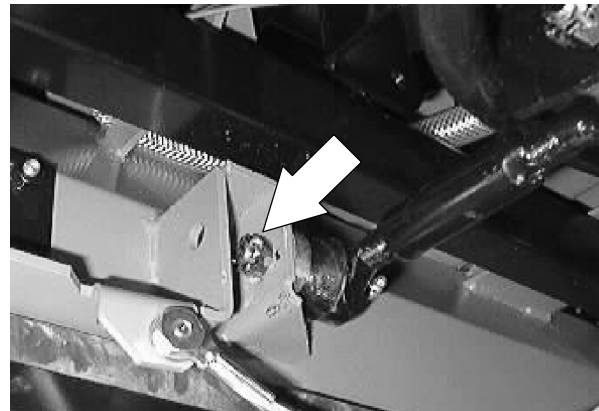

4. Remove the castle nuts from each end of the link. Remove the spacers from the tapered shaft of the link.

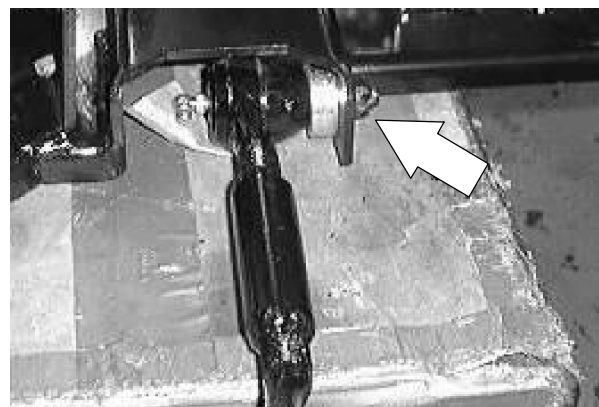

## SCRUBBING

5. Reinstall the spacers on the tapered shaft on both ends of the new scrub head link.

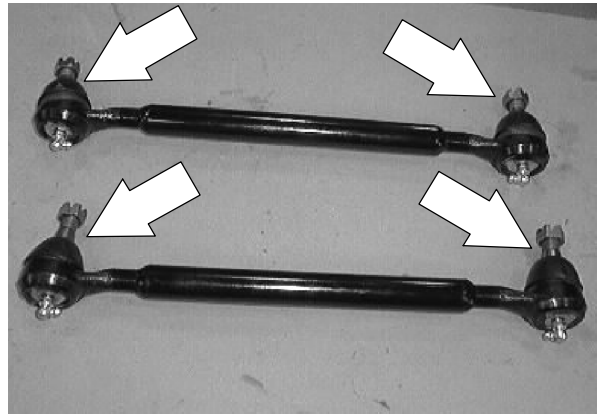

6. Install the new link and spacer in the hole in the front of the scrub head. Reinstall the castle nut and tighten to 90 - 117 Nm (65 - 85 ft lb). Turn the castle nut far enough to line up with the cotter pin hole.

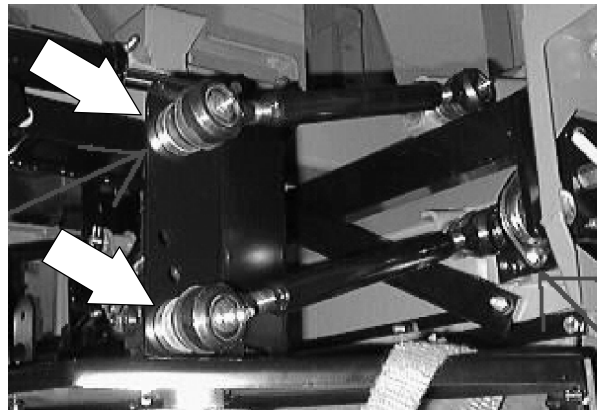

7. Install the other end of the scrub head link in the hole in the machine frame. Reinstall the castle nut and tighten to 90 - 117 Nm (65 - 85 ft lb). Turn the castle nut far enough to line up with the cotter pin hole. Reinstall both cotter pins.

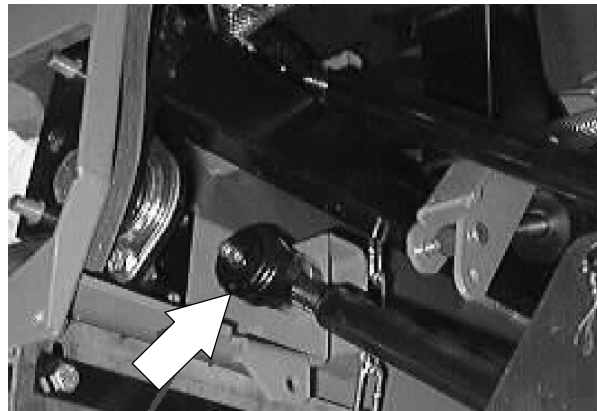

8. Lubricate the pivot points with a grease gun containing Lubriplate EMB grease after installation and after every 200 hours of operation.

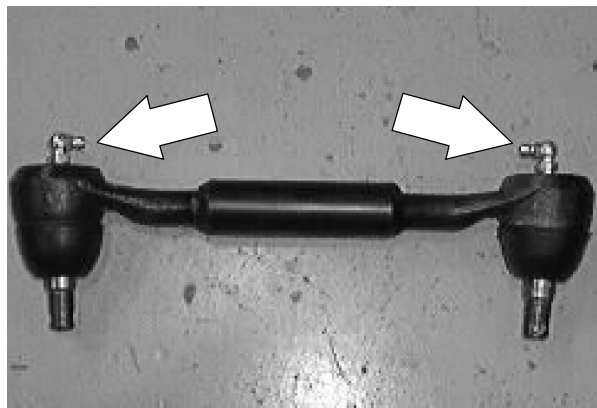

## TO REMOVE 2 MOTOR SCRUB HEAD (stationary)

**FOR SAFETY: Before Leaving Or Servicing Machine; Stop On Level Surface, Set Parking Brake, Turn Off Machine And Remove Key.**

1. Start the machine and lower the scrub head and rear squeegee. Shut off the machine.

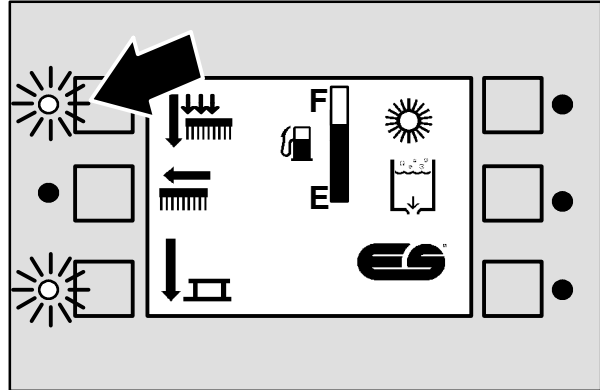

2. Raise the engine cover and disconnect the battery.



3. Raise the back of the machine and install jack stands under the frame.

**FOR SAFETY: Block machine tires before jacking machine up. Jack machine up at designated locations only. Block machine up with jack stands.**



## SCRUBBING

4. Remove the side squeegee shift cable from the left side squeegee at the ball joint.

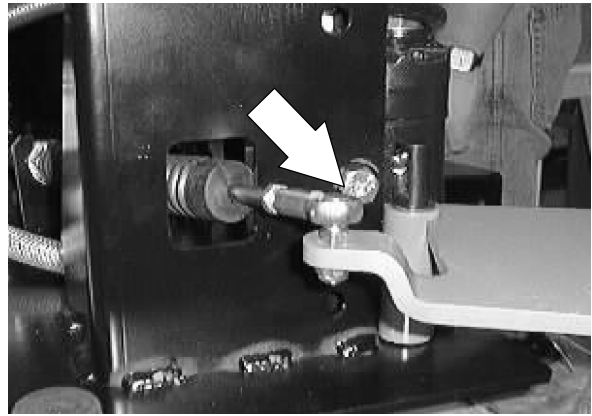

5. Mark, disconnect, and plug the hydraulic hoses leading from the machine to the scrub brush motors (*do not disconnect the hydraulic hoses leading from one scrub brush motor to the other*).

*NOTE: Observe hydraulic cleanliness requirements when opening hydraulic lines.*

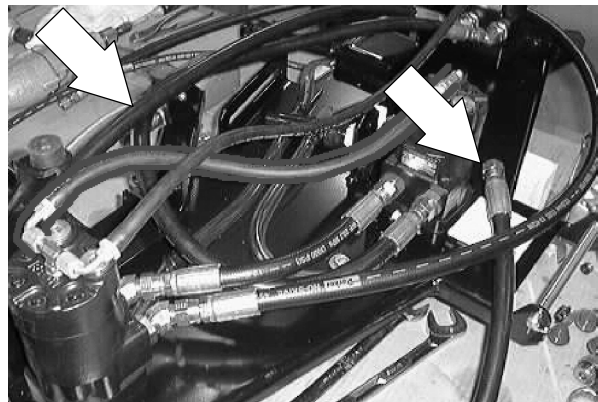

6. Disconnect the solution hose from the fitting in the center of the scrub head.

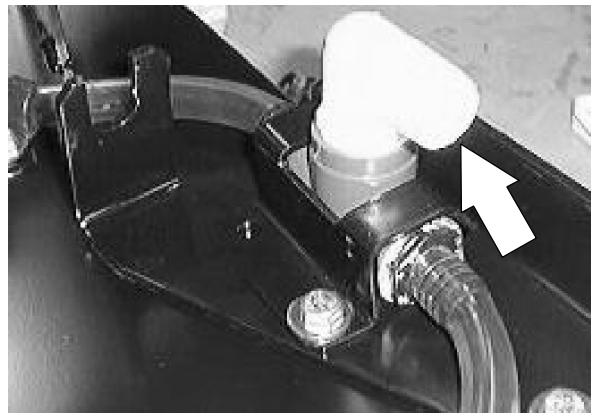

7. Remove the screw holding the center lift rod end to the mount frame.

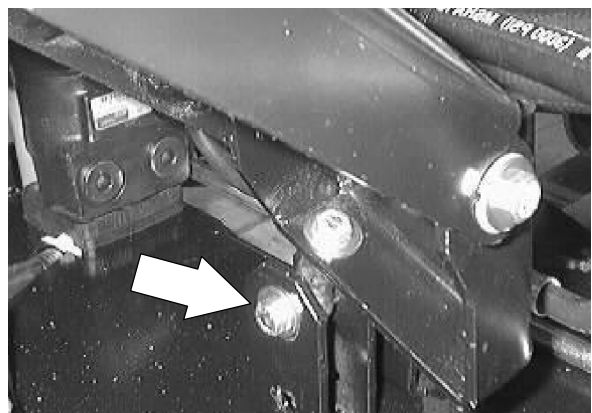



8. Remove the screw holding the front of the scrub head frame to the side movement limiter bracket.



9. Remove the screws and nuts from the four scrub head links where they attach to the scrub head frame. Place the links out of the way for scrub head removal.



10. The scrub head can now be removed from the machine by bringing it out from under the frame on the left hand side.

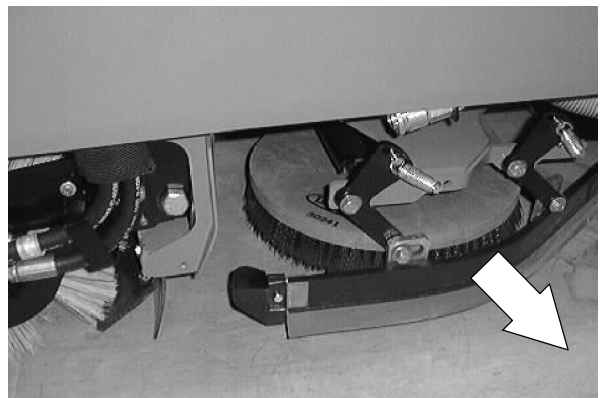

## SCRUBBING

### TO INSTALL 2 MOTOR SCRUB HEAD (stationary)

**FOR SAFETY: Block machine tires before jacking machine up. Jack machine up at designated locations only. Block machine up with jack stands.**

1. Raise the rear of the machine and install jack stands under the frame.



2. Position scrub head under machine frame from the left hand side.

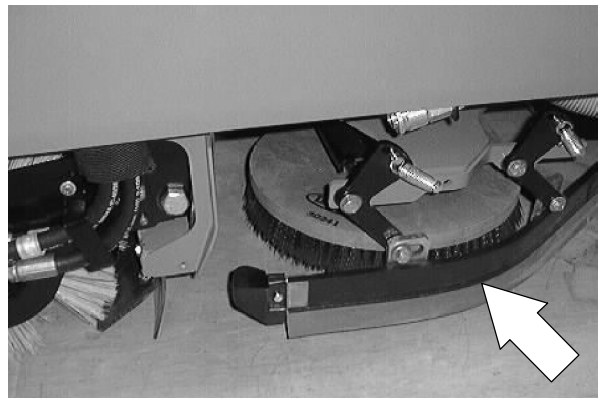

3. Reinstall the scrub head links in the holes in the scrub head frame. Tighten the hardware to 18 - 24 Nm (15 - 20 ft lb).

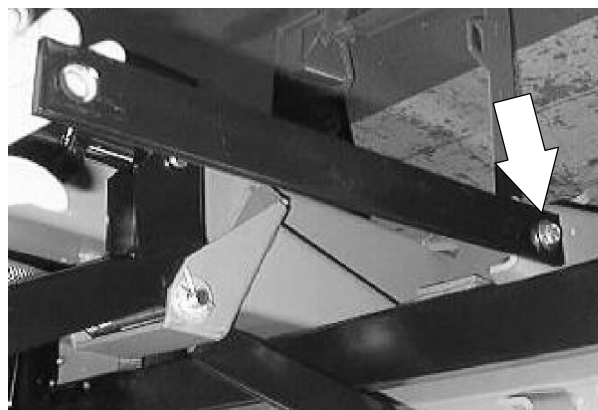

- Reinstall the head lift pivot rod end onto the lift bracket. Tighten hardware to 18 - 24 Nm (15 - 20 ft lb).

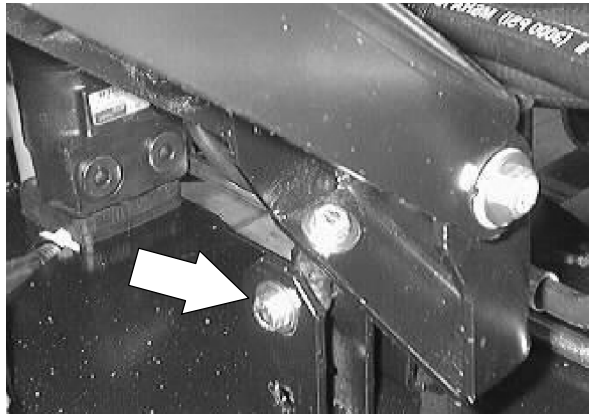

- Reinstall the front of the scrub head frame to the side link. Tighten hardware to 18 - 24 Nm (15 - 20 ft lb).



- Reconnect the main solution feed line to the fitting in the center of the scrub head.

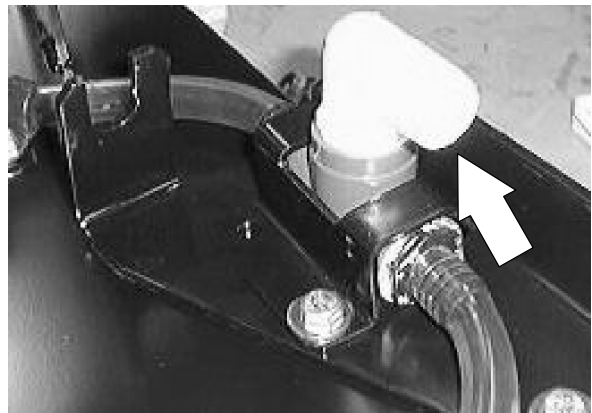

- Reconnect the hydraulic hoses to the two brush motors. See schematic in the HYDRAULICS section.

*NOTE: Observe hydraulic cleanliness requirements when opening hydraulic lines.*

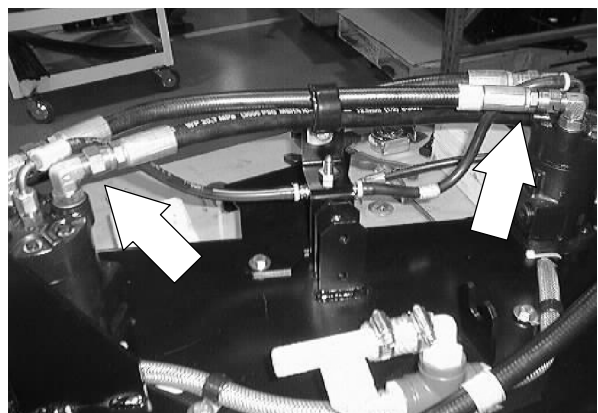

## SCRUBBING

8. Reinstall the side squeegee shift cable into the mount slot and tighten the two jam nuts.

*NOTE: Install the push-pull cable so there is 2-3/16 inch from the center of the bracket to the end of the cable steel area.*

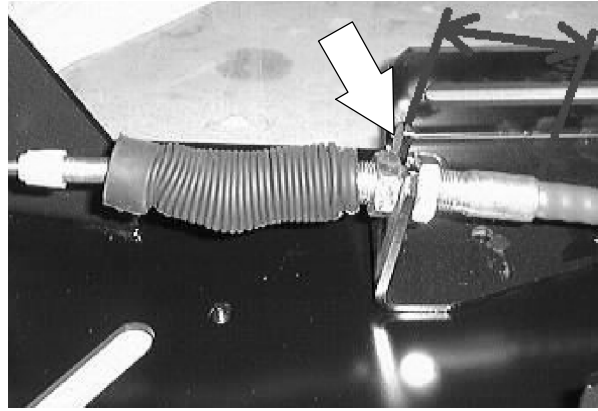

9. Reinstall the side squeegee shift cable to the left side squeegee at the ball joint.

*NOTE: Make sure the balljoint is threaded all the way onto the cable. The distance between the middle of the balljoint and the middle of the bracket on the scrub head should be 10.64 inches.*

*NOTE: Make sure to reinstall any clamps or plastic ties that were removed during disassembly.*

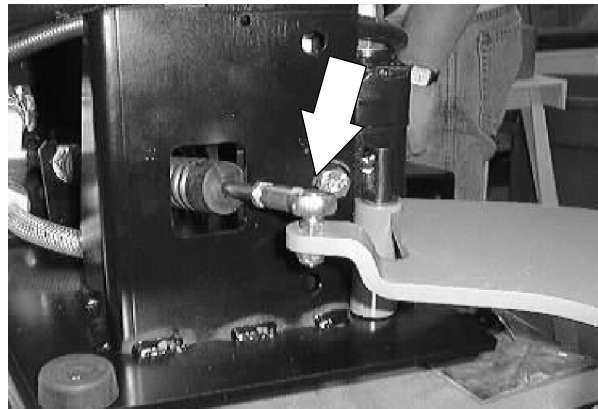

10. Reconnect the battery and close the engine cover.

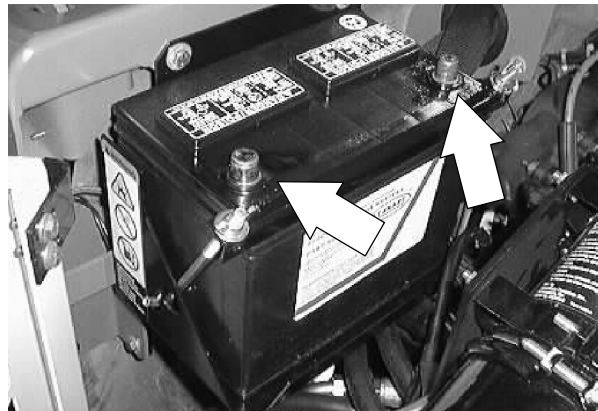

11. Remove the jack stands and lower the machine. Check for proper operation of the scrub brushes and head lift.



## TO REMOVE 2 MOTOR SCRUB HEAD (with side-shift option)

**FOR SAFETY: Before Leaving Or Servicing Machine; Stop On Level Surface, Set Parking Brake, Turn Off Machine And Remove Key.**

1. Start the machine and lower the scrub head.

*NOTE: Make sure the scrub head is shifted all the way in, under the machine.*

2. Shut off the machine.

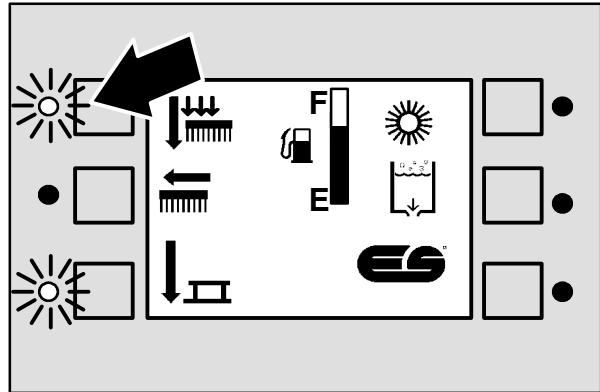

3. Raise the engine cover and disconnect the battery.

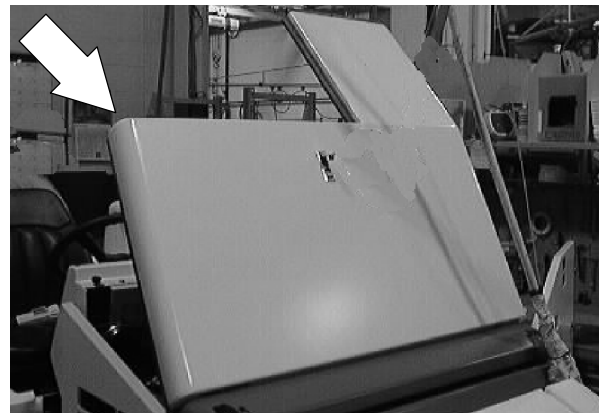

4. Raise the back of the machine and install jack stands under the frame.

**FOR SAFETY: Block machine tires before jacking machine up. Jack machine up at designated locations only. Block machine up with jack stands.**



## SCRUBBING

5. Remove the hitch pin holding the scrub head deflector arm to the right side of the scrub head.

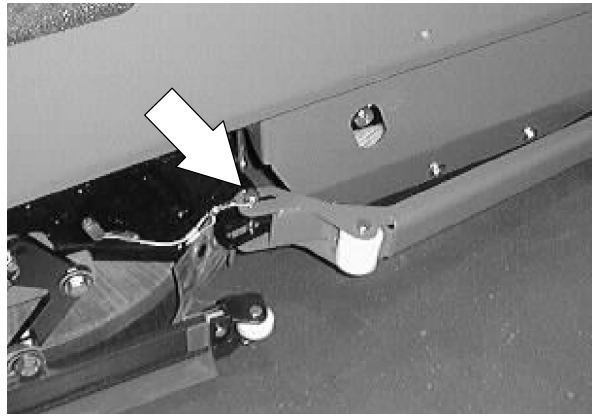

6. Remove the side squeegee shift cable from the left side squeegee at the ball joint. Loosen the two jam nuts on the cable and remove from the mount slot.

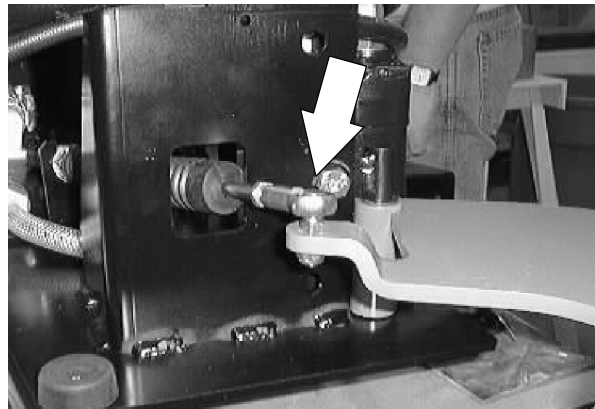

7. Mark, disconnect, and plug the hydraulic hoses leading to the two scrub brush motors.

*NOTE: Observe hydraulic cleanliness requirements when opening hydraulic lines.*

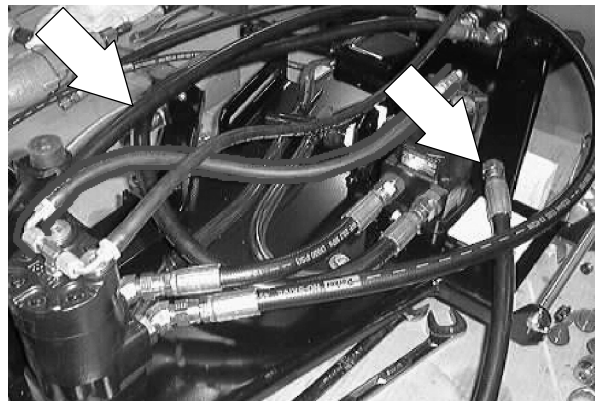

8. Disconnect the solution hose from the fitting in the center of the scrub head.

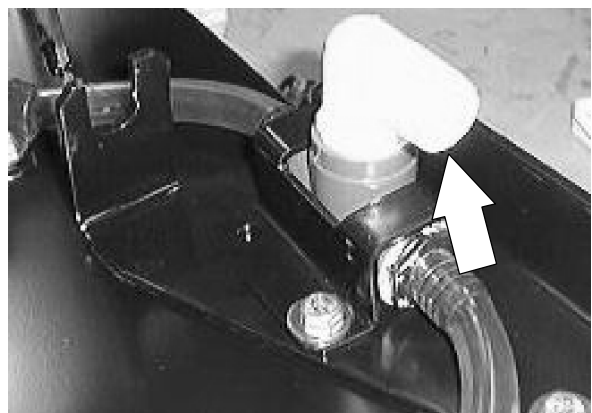

9. Pull the clip up on the end of the side shift gas spring and remove it from the ball on the LH side of the scrub head.

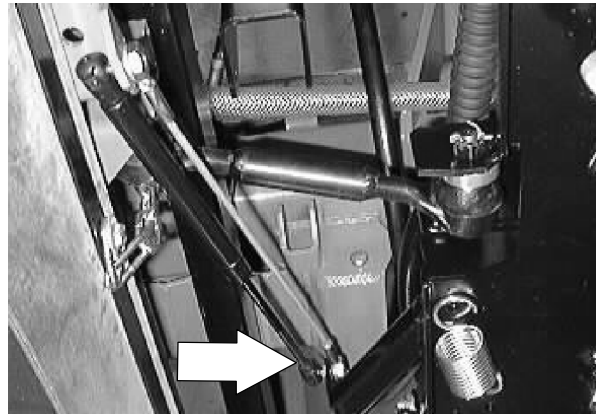

10. Remove the ball end and nut holding the side shift pull cable to the scrub head.

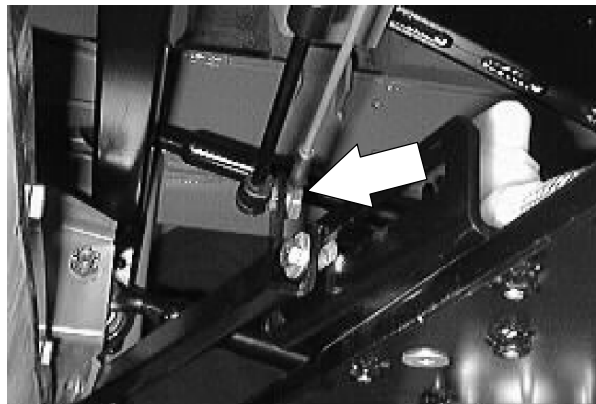

11. Remove the screw holding the center lift bracket roller to the mount frame. Remove the roller.

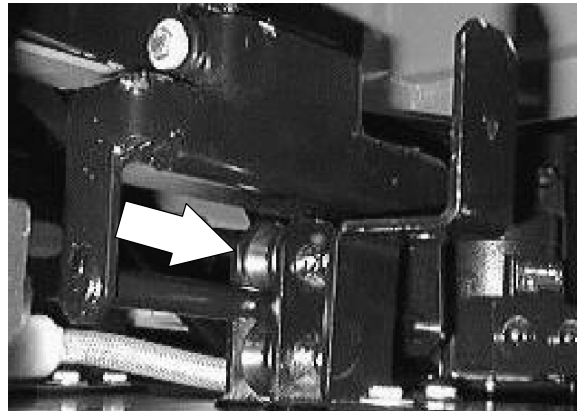

12. Remove the screw and nut holding the scrub head side shift limiter bracket to the front of the scrub head frame.



## SCRUBBING

13. Remove the cotter pins and castle nuts from the four scrub head links where they attach to the scrub head frame. Place the links up and out of the way for scrub head removal.

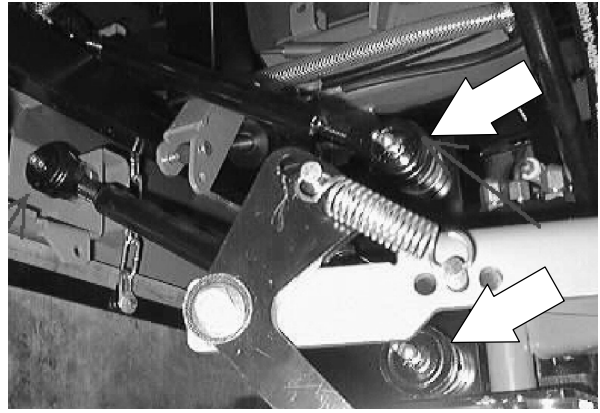

14. The scrub head can now be removed from the machine by bringing it out from under the frame on the left hand side.

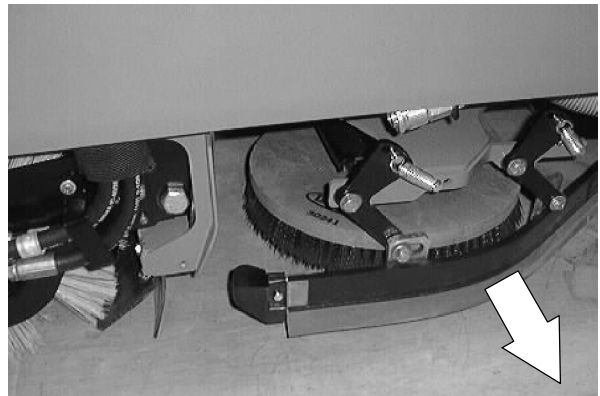



**TO INSTALL 2 MOTOR SCRUB HEAD  
(with edge scrub option)**

**FOR SAFETY: Block machine tires before jacking machine up. Jack machine up at designated locations only. Block machine up with jack stands.**

1. Raise the rear of the machine and install jack stands under the frame.



2. Position scrub head under machine frame from the left hand side.



3. Reinstall the four scrub head links in the mount holes on the scrub head frame.

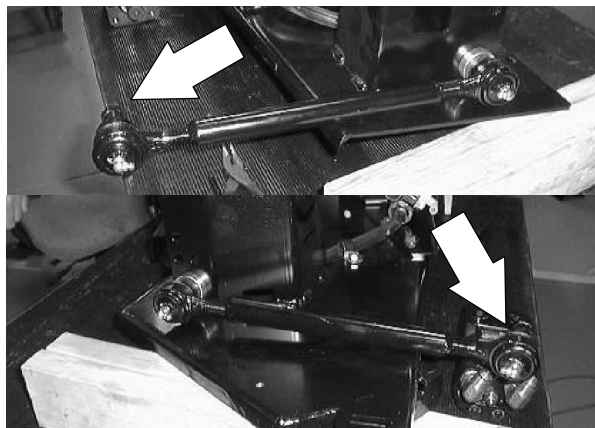

## SCRUBBING

4. Reinstall the castle nuts on the scrub head links and tighten to 90 - 117 Nm (65 - 85 ft lb). Turn the castle nut far enough to line up with the cotter pin hole. Reinstall the cotter pin.

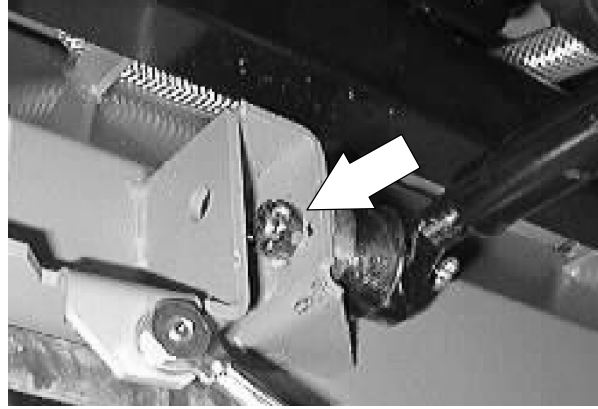

5. Reinstall the head lift pivot roller on the lift bracket. Tighten hardware to 18 - 24 Nm (15 - 20 ft lb).

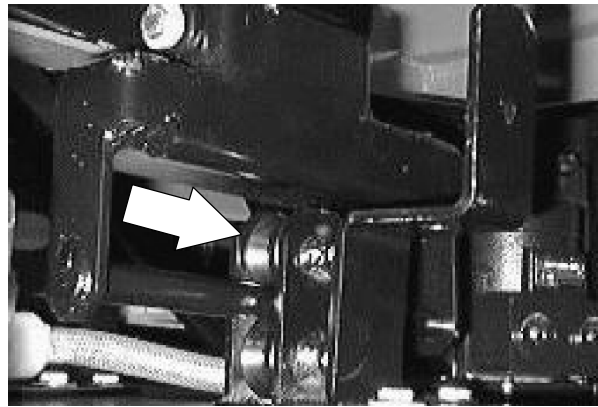

6. Reconnect side shift return cable and nut on the rear of the scrub head. Tighten the nut to the point where the cable is able to rotate.

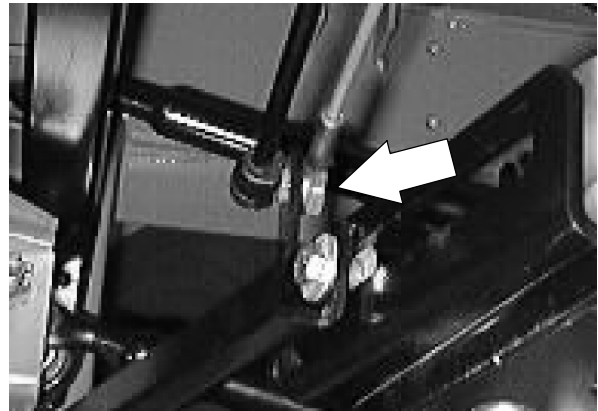

7. Install gas spring onto the ball on the front side of the scrub head. Make sure the locking clip re-seats itself.



- Reinstall the scrub head side shift limiter bracket on the front of the scrub head frame. Tighten hardware to 18 - 24 Nm (15 - 20 ft lb).

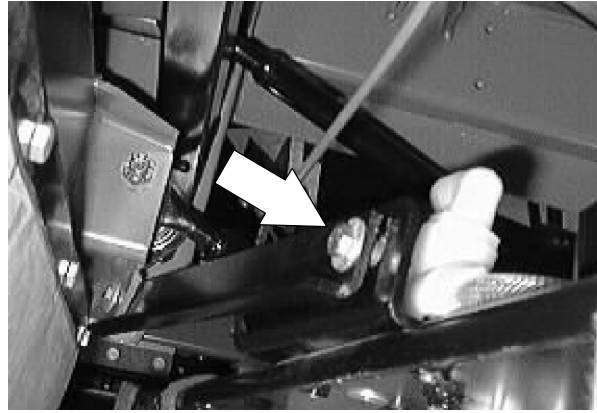

- Reconnect the main solution feed line to the fitting in the center of the scrub head.

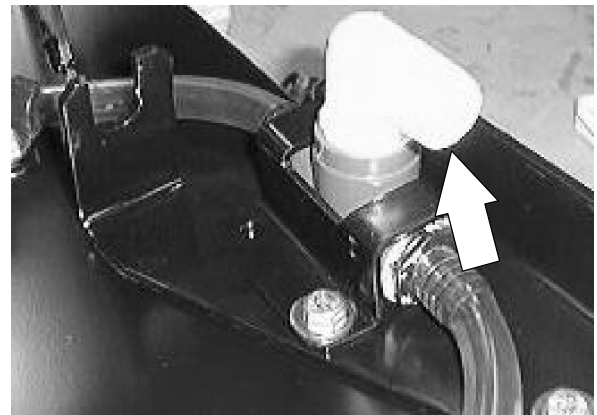

- Reconnect the hydraulic hoses to the two brush motors. See schematic in the HYDRAULICS section.

*NOTE: Observe hydraulic cleanliness requirements when opening hydraulic lines.*

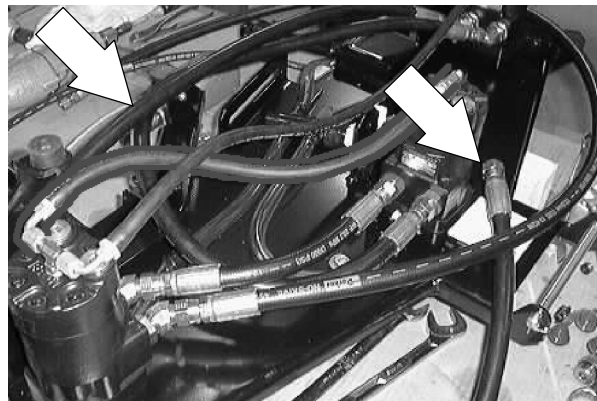

- Reinstall the side squeegee shift cable into the mount slot and tighten the two jam nuts.

*NOTE: Install the push-pull cable so there is 2-3/16 inch from the center of the bracket to the end of the cable steel area.*

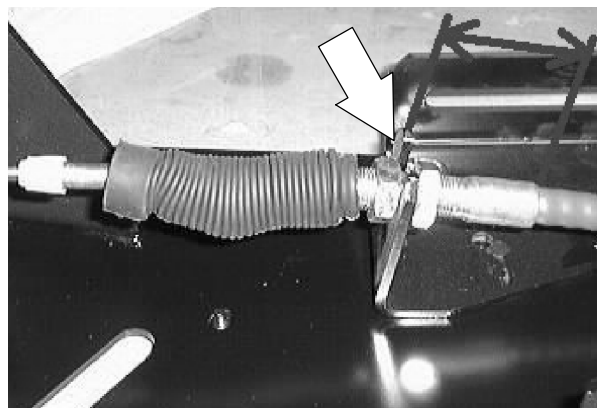

## SCRUBBING

12. Reinstall the side squeegee shift cable to the left side squeegee at the ball joint.

*NOTE: Make sure the balljoint is threaded all the way onto the cable. The distance between the middle of the balljoint and the middle of the bracket on the scrub head should be 10.64 inches.*

*NOTE: Make sure to reinstall any clamps or plastic ties that were removed during disassembly.*

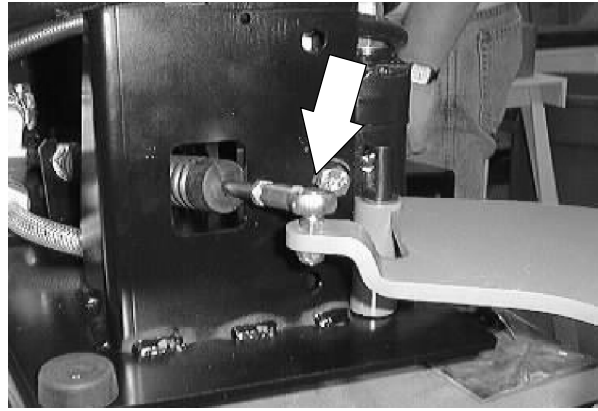

13. Reinstall the scrub head deflector arm onto the right hand side of the scrub head. Reinstall the hitch pin.



14. Reconnect the battery and close the engine cover.

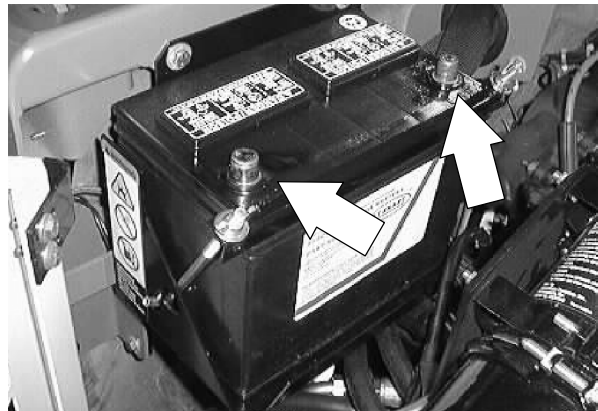

15. Remove the jack stands and lower the machine. Check for proper operation of the scrub brushes and side shift.



## TO REMOVE 3 MOTOR SCRUB HEAD (Max pro 1200)

**FOR SAFETY: Before Leaving Or Servicing Machine; Stop On Level Surface, Set Parking Brake, Turn Off Machine And Remove Key.**

1. Start the machine and lower the scrub head.

*NOTE: Make sure the scrub head is shifted all the way in, under the machine.*

2. Shut off the machine.

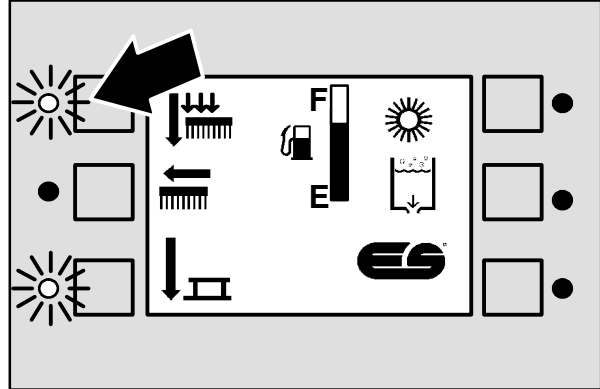

3. Raise the engine cover and disconnect the battery.

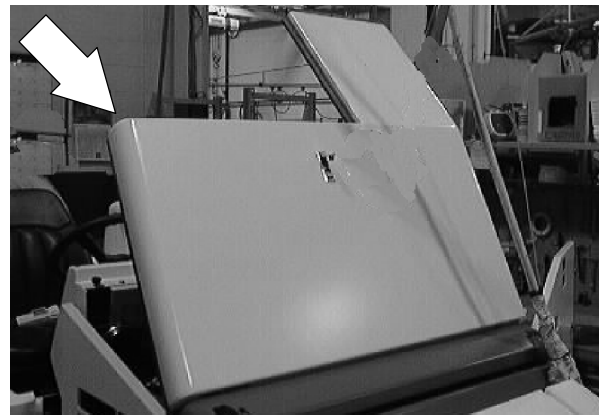

4. Raise the back of the machine and install jack stands under the frame.

**FOR SAFETY: Block machine tires before jacking machine up. Jack machine up at designated locations only. Block machine up with jack stands.**



## SCRUBBING

5. Remove the hitch pin holding the scrub head deflector arm to the right side of the scrub head.

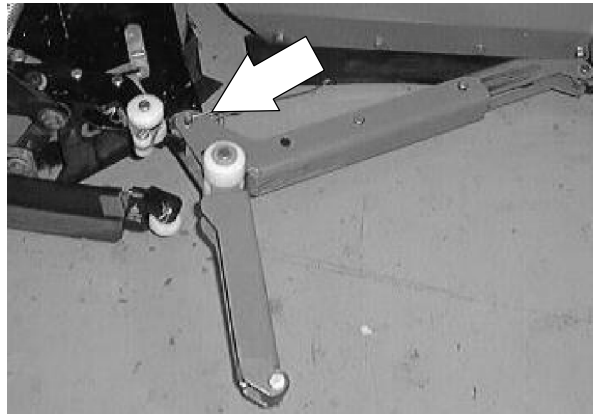

6. Remove the side squeegee shift cable from the left side squeegee at the ball joint. Loosen the two jam nuts on the cable and remove from the mount slot.

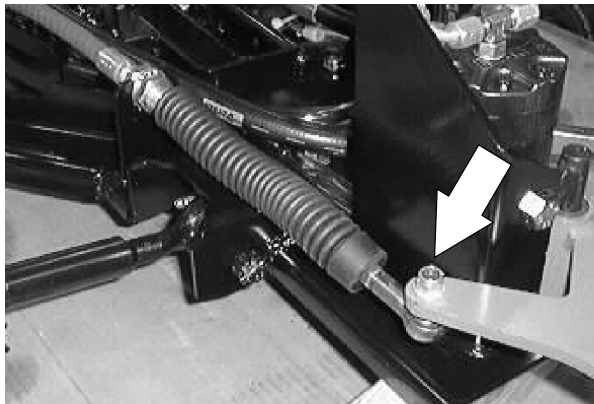

7. Mark, disconnect, and plug the hydraulic hoses leading to the three scrub brush motors.

*NOTE: Observe hydraulic cleanliness requirements when opening hydraulic lines.*

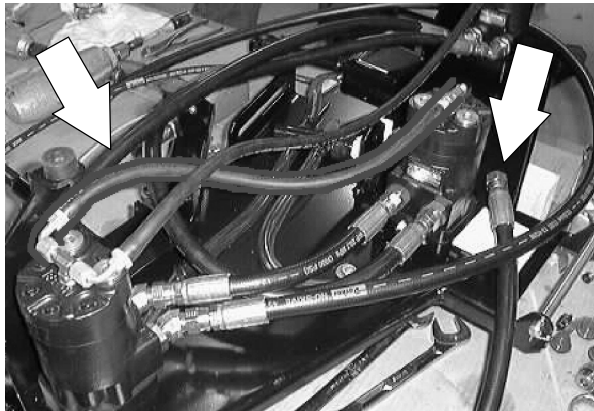

8. Disconnect the solution hose from the fitting in the center of the scrub head.



9. Pry the clip up on the end of the side shift gas spring. Remove the ball on the LH side of the scrub head.



10. Remove the ball end and nut holding the scrub head side shift pull cable to the scrub head.

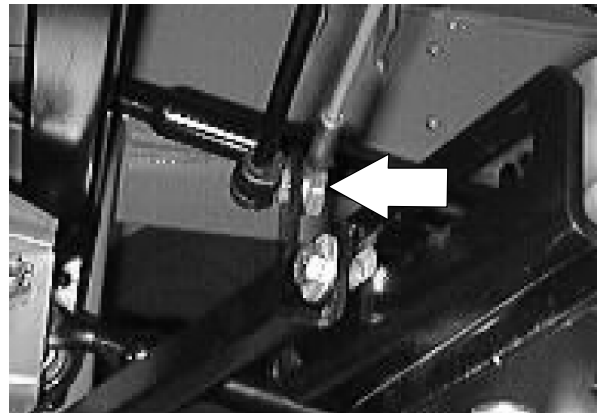

11. Remove the screw holding the center lift bracket roller to the mount frame. Remove the roller.

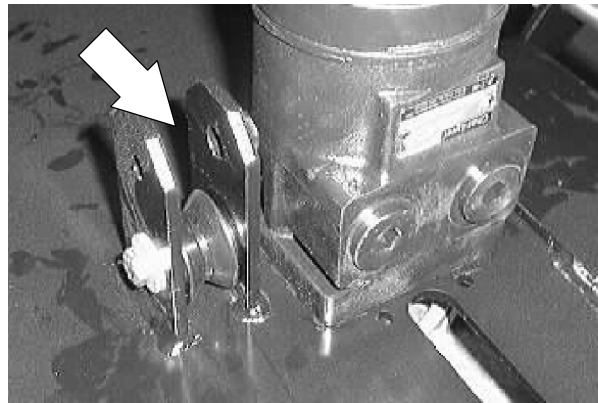

12. Remove the screw and nut holding the scrub head side shift limiter bracket to the front of the scrub head frame.

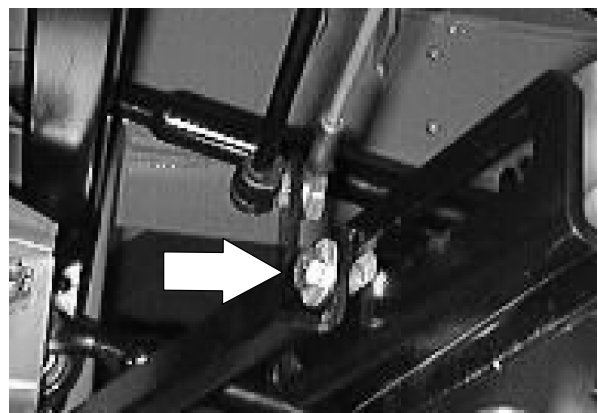

## SCRUBBING

13. Remove the cotter pins and castle nuts from the two scrub head links where they attach to the scrub head frame. Place the links out of the way for scrub head removal.

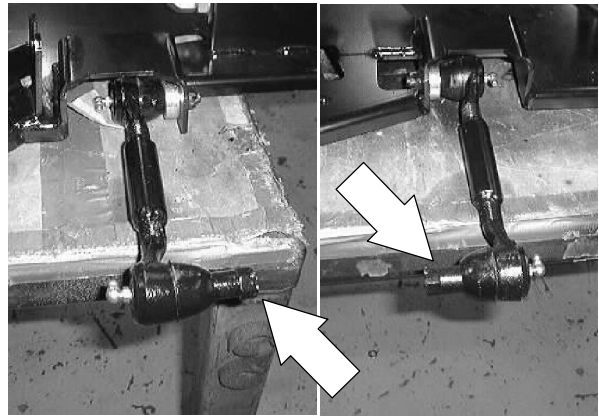

14. The scrub head can now be removed from the machine by bringing it out from under the frame on the left hand side.

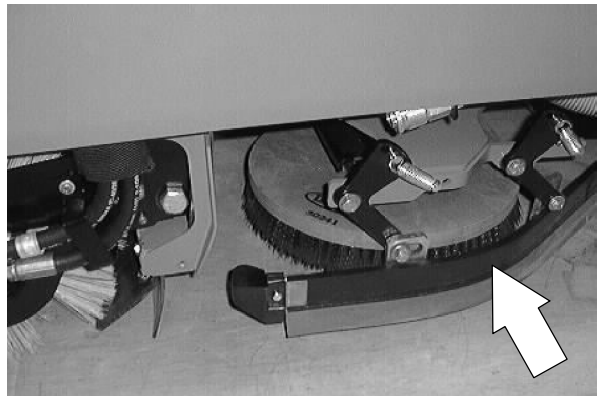



**TO INSTALL 3 MOTOR SCRUB HEAD  
(Max pro 1200) (retractable)**

**FOR SAFETY: Before Leaving Or Servicing Machine; Stop On Level Surface, Set Parking Brake, Turn Off Machine And Remove Key.**

1. Raise the rear of the machine and install jack stands under the frame.



2. Position scrub head under machine frame from the left hand side.

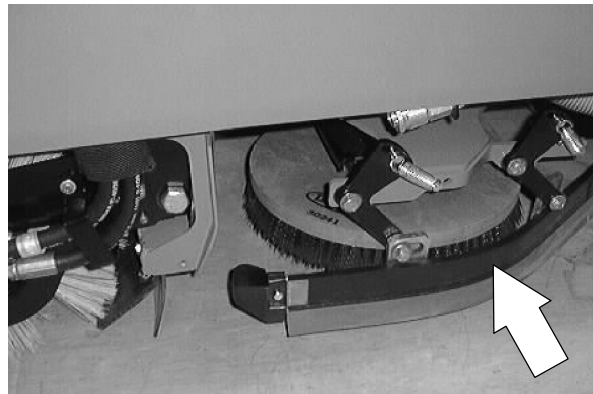

3. Reinstall the two scrub head links in the mount holes in the scrub head frame.

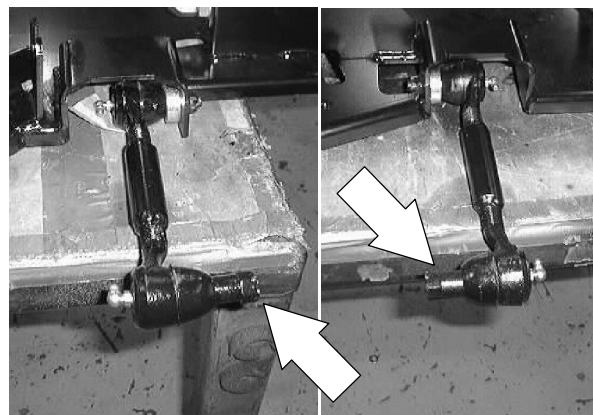

## SCRUBBING

4. Reinstall the castle nuts on the scrub head links and tighten to 90 - 117 Nm (65 - 85 ft lb). Turn the castle nut far enough to line up with the cotter pin hole. Reinstall the cotter pin.

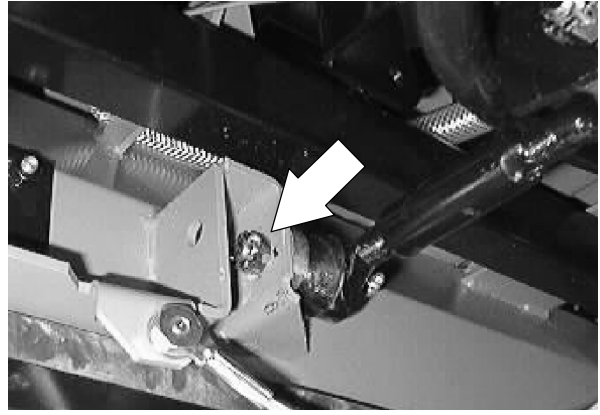

5. Reinstall the head lift pivot roller on the lift bracket. Tighten hardware to 18 - 24 Nm (15 - 20 ft lb).

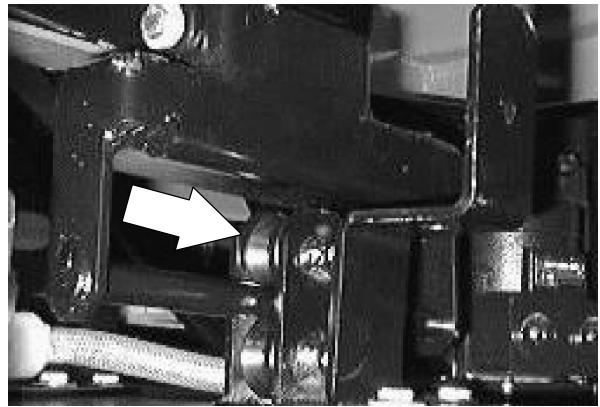

6. Reconnect side shift return cable and ball nut end on the rear side of the scrub head. Tighten the nut to the point where the cable can still rotate.

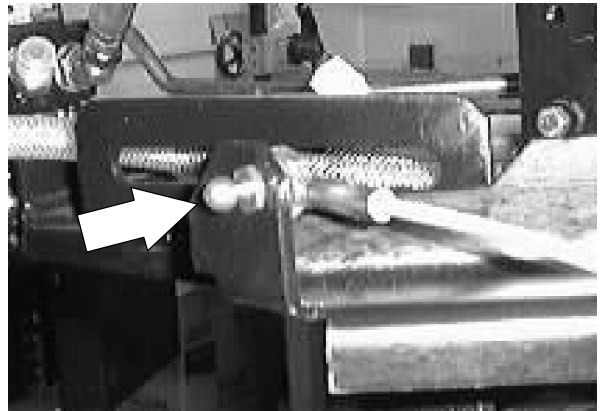

7. Install gas spring onto the ball on the front side of the scrub head. Make sure the locking clip re-seats itself.

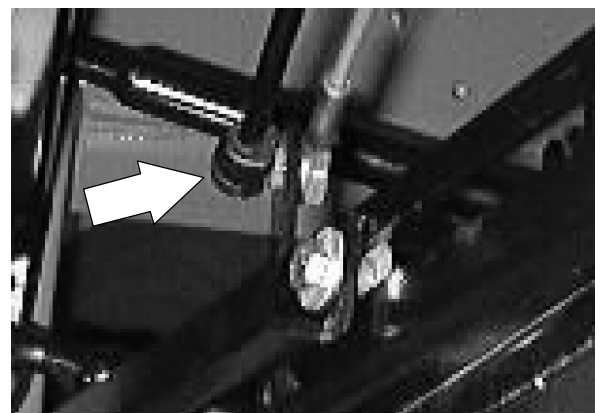

- Reinstall the scrub head side shift limiter bracket on the front of the scrub head frame. Tighten hardware to 18 - 24 Nm (15 - 20 ft lb).

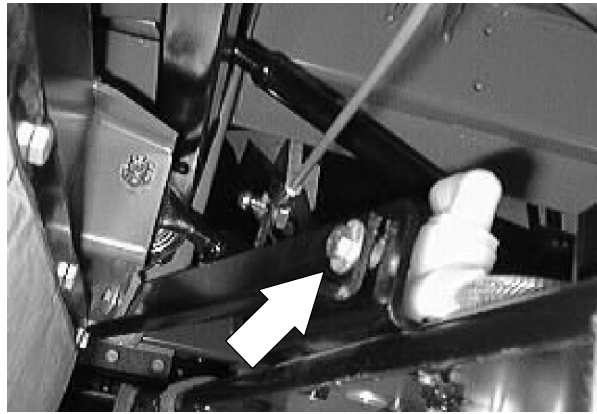

- Reconnect the main solution feed line to the fitting in the center of the scrub head.



- Reconnect the hydraulic hoses to the three brush motors. See schematic in the HYDRAULICS section.

*NOTE: Observe hydraulic cleanliness requirements when opening hydraulic lines.*

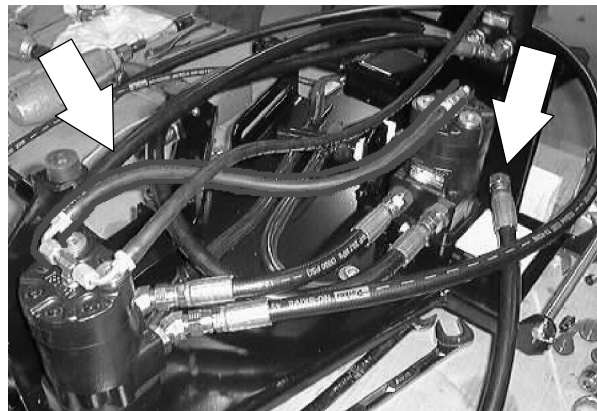

- Reinstall the side squeegee shift cable into the mount slot and tighten the two jam nuts.

*NOTE: Install the push-pull cable so there is 2-3/16 inch from the center of the bracket to the end of the cable steel area.*

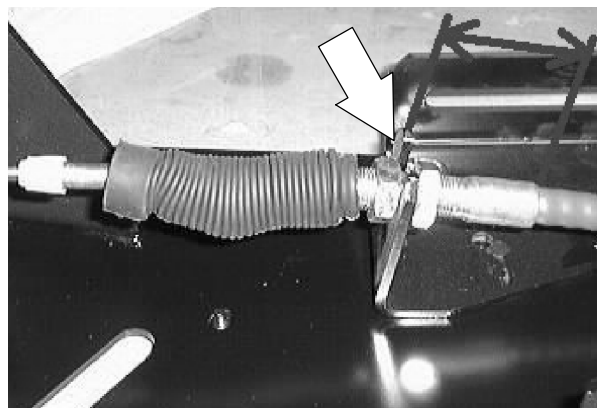

## SCRUBBING

12. Reinstall the side squeegee shift cable to the left side squeegee at the ball joint.

*NOTE: Make sure the balljoint is threaded all the way onto the cable. The distance between the middle of the balljoint and the middle of the bracket on the scrub head should be 10.64 inches.*

*NOTE: Make sure to reinstall any clamps or plastic ties that were removed during disassembly.*

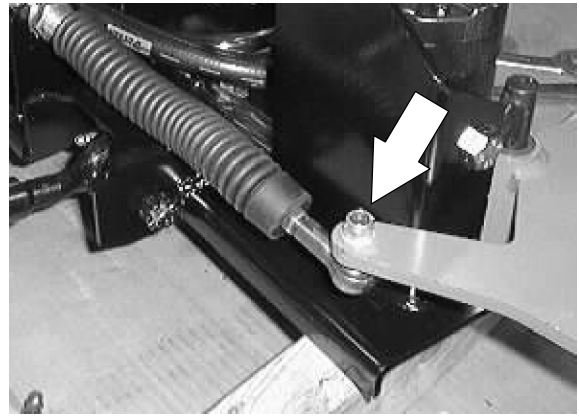

13. Reinstall the scrub head deflector arm onto the right hand side of the scrub head. Reinstall the hitch pin.

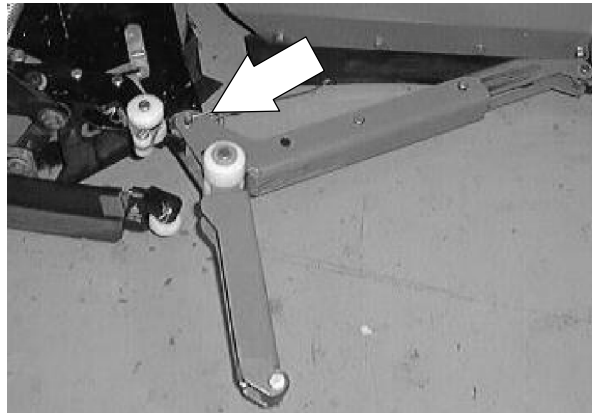

14. Reconnect the battery and close the engine cover.

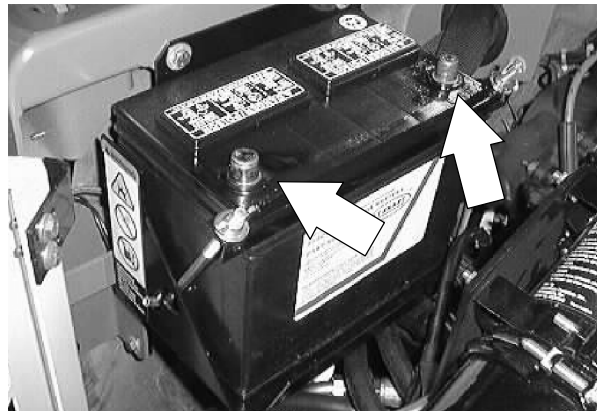

15. Remove the jack stands and lower the machine. Check for proper operation of the scrub brushes and side shift.



**SCRUB HEAD SKIRTS**

The scrub head floor skirts control water spray from the brushes. The skirts are located at the front right corner of the scrub head on all models and at the rear edge of the scrub head on the two brush head. Check these skirts for wear and damage after every 50 hours of operation.

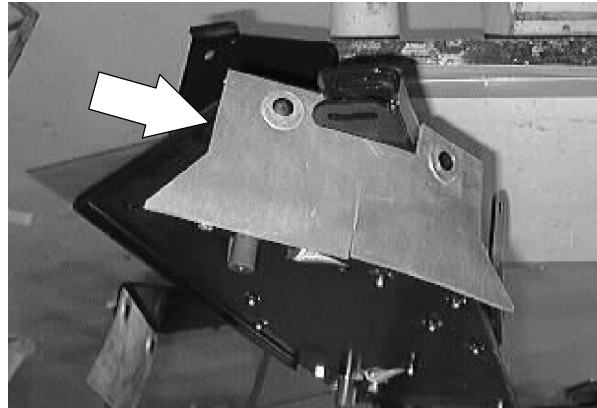

The skirts should clear the floor by 0 to 0.25 in (0 to 6 mm) when the scrub head is down. Check the floor skirt adjustment after every 50 hours of operation.

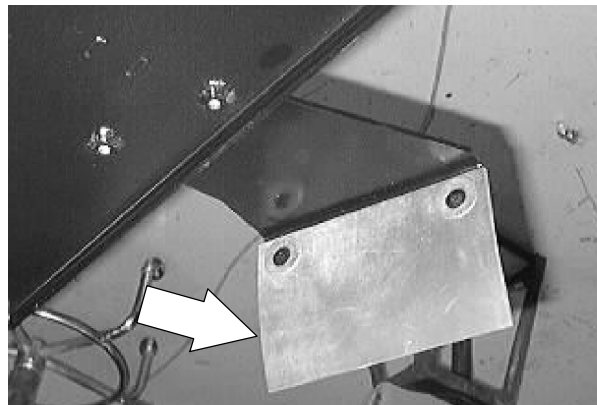

**TO REPLACE SCRUB HEAD SKIRTS**

1. Raise the scrub head and turn off the machine.

**FOR SAFETY: Before Leaving Or Servicing Machine; Stop On Level Surface, Set Parking Brake.**

2. Remove the two plastic rivets holding the skirts to the scrub head. Remove and discard the skirt.

3. Position the new skirts on the mount brackets. Reinstall the plastic rivets.

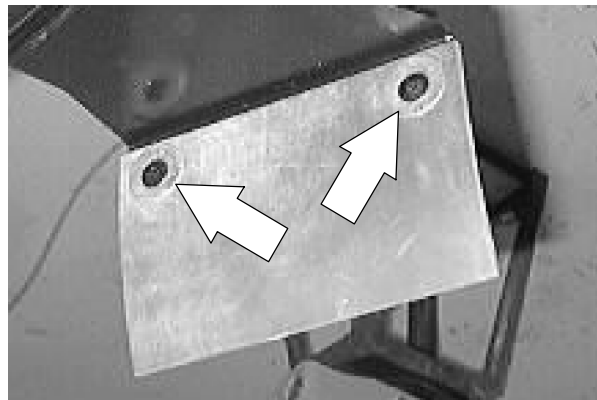

## SCRUB BRUSHES

Disc-type scrub brushes scrub the floor. Each scrub brush is driven by its own hydraulic motor and drive hub. A spring lock clip holds the scrub brush onto the drive hub.

There are many variations of brushes and cleaning pads to choose from. There is a brush or cleaning pad available for almost any application. Scrub brushes are ready for use when they are equipped with a brush drive plate and a spring clip.

The scrub brushes should be checked daily for tangled wire or string wear damage. The scrub brushes should be replaced if large portions of the brush bristles are missing or if the remaining brush bristle measure 0.50 in (12 mm) or less in length.

*NOTE: Be sure to replace the scrub brushes in sets. Otherwise one scrub brush will be more aggressive than the other.*

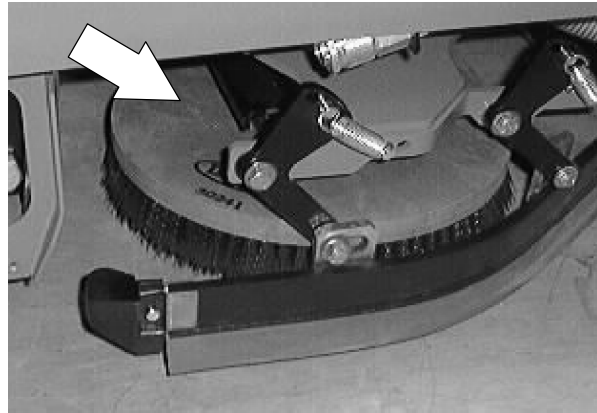

## TO REPLACE SCRUB BRUSHES

1. With the scrub head raised, turn off the machine and set the machine parking brake.

**FOR SAFETY: Before Leaving Or Servicing Machine; Stop On Level Surface, Set Parking Brake, Turn Off Machine And Remove Key.**

2. Rotate the scrub brush by hand until the spring clip is visible at the edge of the scrub head.
3. Press the brush spring clip ends together with your thumb and index finger to remove the scrub brush.
4. Slide the new scrub brush under the scrub brush drive assembly.
5. Line up the scrub brush drive socket with the drive plug.
6. Press the brush spring clip together and lift the scrub brush onto the drive plug. Release the spring clip when the brush is in place.
7. Repeat this procedure for the other brushes.

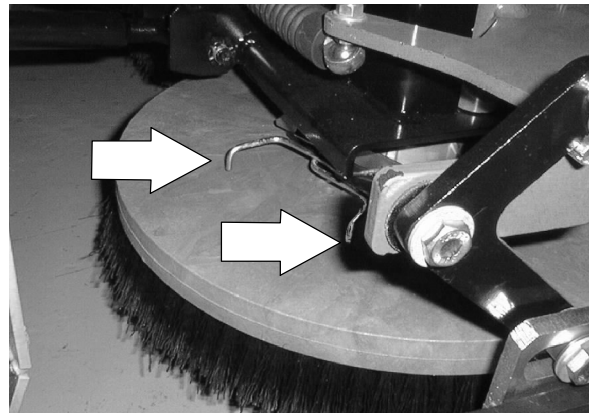

---

## SOLUTION VALVE

---

The flow of solution to the scrub brushes is controlled by two electrical solenoids and an adjustable mechanical valve.

The solenoid solution valves control the flow of solution to the scrub brushes. The solenoid solution valve is a non-mechanical electrical solenoid. The dash mounted switch has a high and low setting.

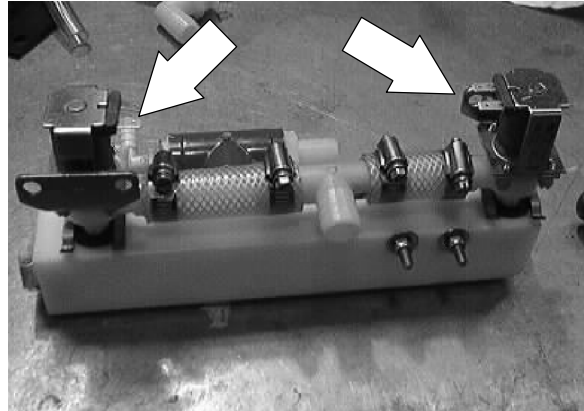

The adjustable mechanical valve is used to custom tailor the amount of solution the scrubber needs in your particular situation. Once the mechanical valve is set to your scrubbing needs--it can be left alone. Solution flow then can be controlled with the dash mounted high and low settings.

-Set the valve to a lower water flow rate (**pin straight up**) when scrubbing smooth, sealed floors.

-Set the valve to a higher water flow rate (**pin 90 degree over to left**) on coarse floors or when double scrubbing.

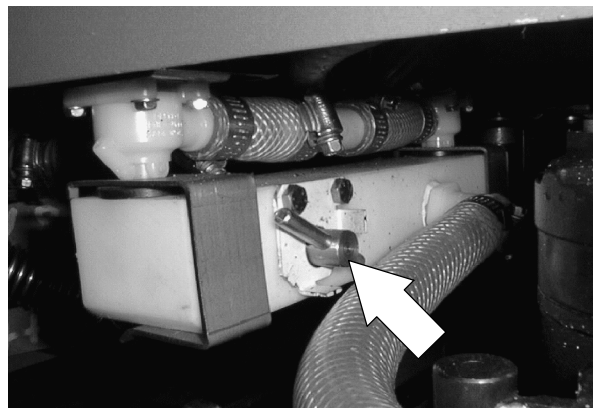

*NOTE: If water trails around the ends of the rear squeegee in turns--set the adjustable valve to a lower water flow rate.*

# SCRUBBING

## SQUEEGEES

### SIDE SQUEEGEES

The side squeegees control water spray and channel water into the path of the rear squeegee. Check the side squeegees for damage and wear daily. Replace the side squeegee blades whenever they become damaged or lose their shape or resiliency. Replace the squeegee deflectors whenever they become worn.

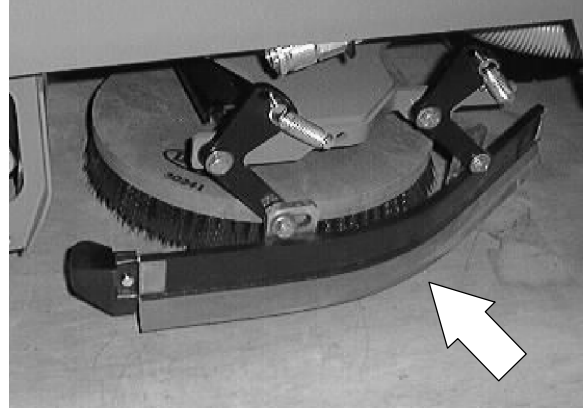

### TO REPLACE SIDE SQUEEGEE BLADES

1. With the scrub head raised, turn off the machine and set the machine parking brake.

**FOR SAFETY: Before Leaving Or Servicing Machine; Stop On Level Surface, Set Parking Brake, Turn Off Machine And Remove Key.**

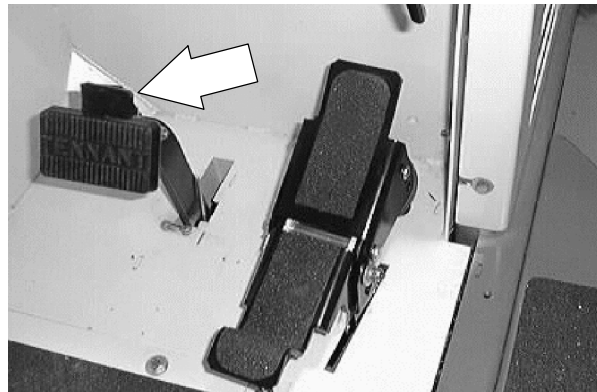

2. Remove the hitch pin holding the scrub head deflector arm to the front edge of the squeegee.

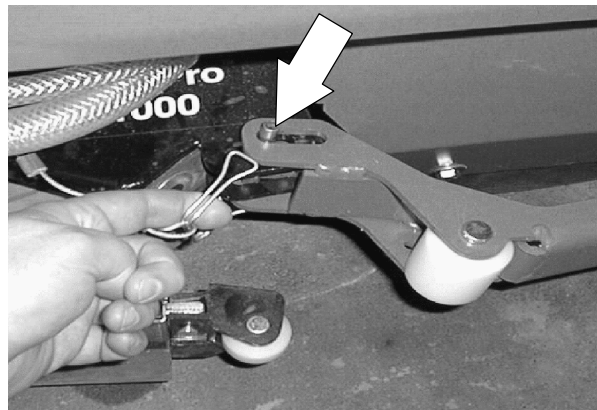



3. Remove the clevis pin and bumper from the front end of the side squeegee.

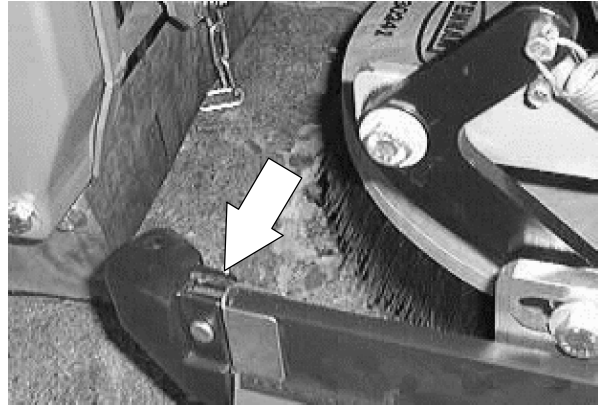

4. RH SIDE SQUEEGEE: Pull the squeegee blade off the mount frame. Discard the squeegee blade.

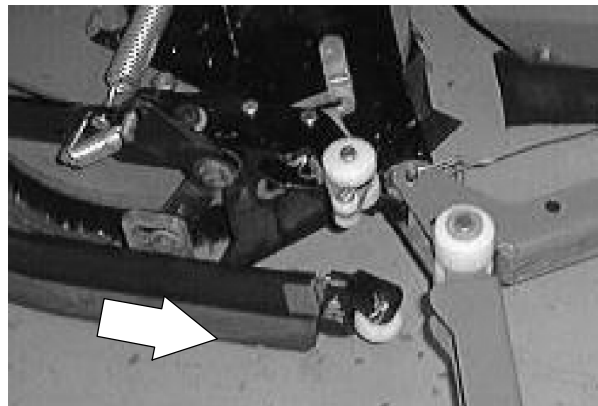

5. LH SIDE SQUEEGEE: Pull the squeegee blade off the mount frame. Discard the squeegee blade.

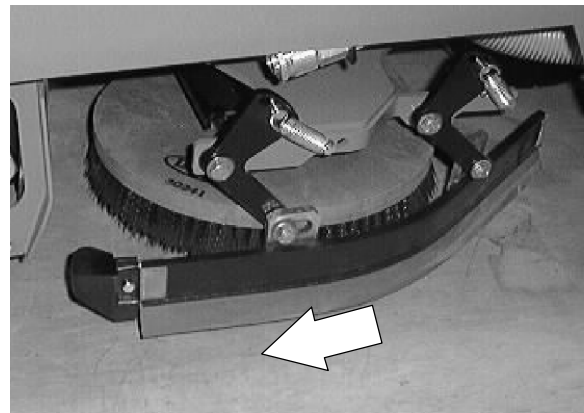

6. Slip the new squeegee blade onto the side squeegee frame.

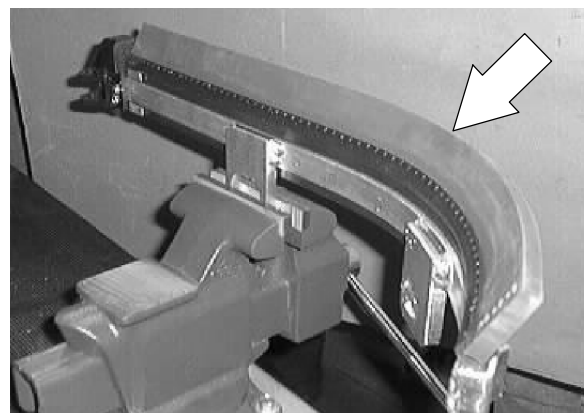

## SCRUBBING

7. Reinstall the squeegee bumper and clevis pin on the front end of the side squeegee.

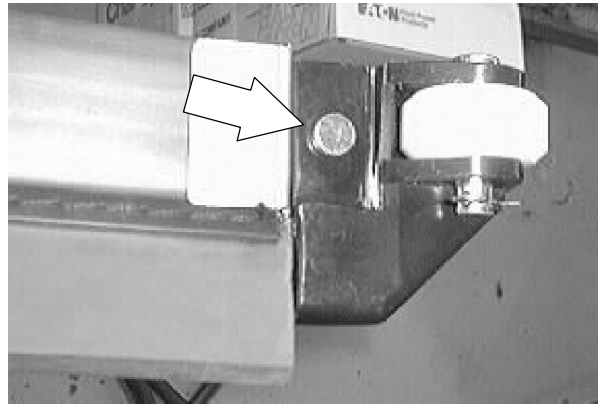

8. Reinstall the deflector arm and hitch pin.

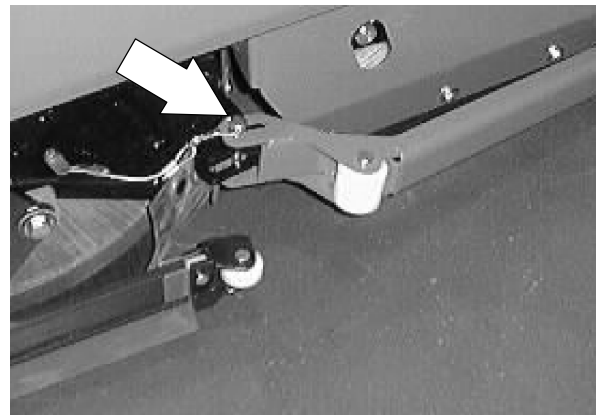

9. Operate the machine and check the side squeegees for proper operation.

## TO REPLACE SIDE SQUEEGEE PIVOT CABLE

1. Start the machine and lower the rear squeegee and scrub head. Shut off the machine.

**FOR SAFETY: Before Leaving Or Servicing Machine; Stop On Level Surface, Set Parking Brake, Turn Off Machine And Remove Key.**

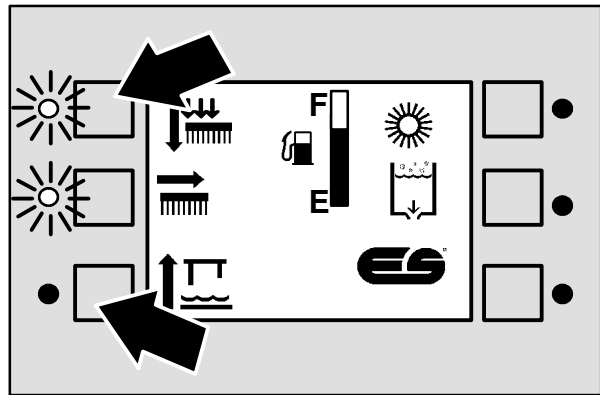

2. Locate the solution valve mount assembly under the operator compartment. Remove the screws holding the mount plate to the frame. Let the valve assembly drop down.

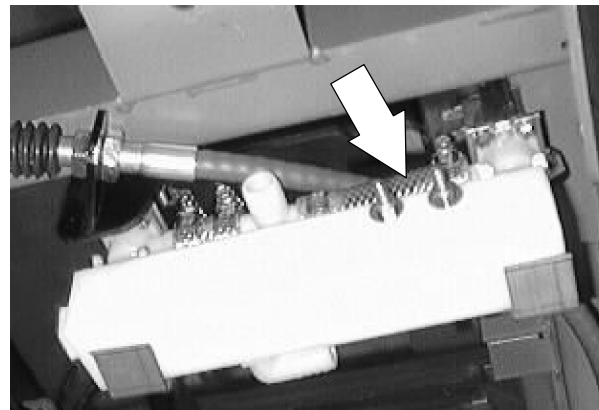

3. Loosen the two large jam nuts on the squeegee pivot cable where it attaches to the solution valve mount bracket. Pull the cable out of the slot.

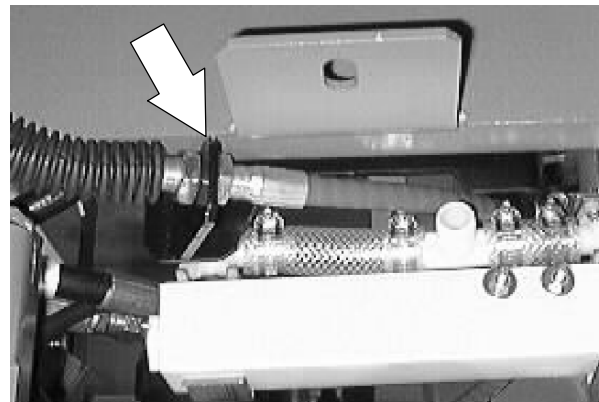

4. Remove the nut holding the cable balljoint to the squeegee pivot bracket.

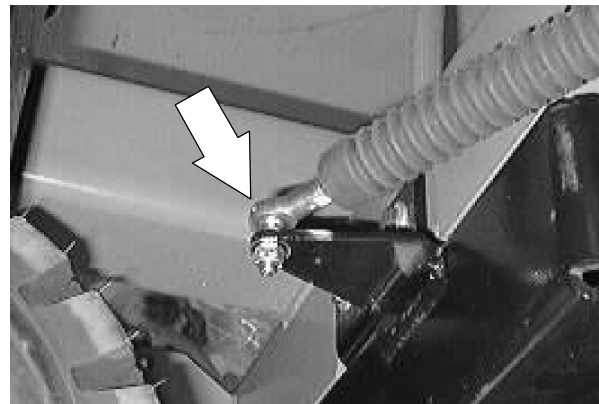

## SCRUBBING

5. Loosen the two large jam nuts on the squeegee pivot cable where it attaches to the bracket on the left side of the scrub head.

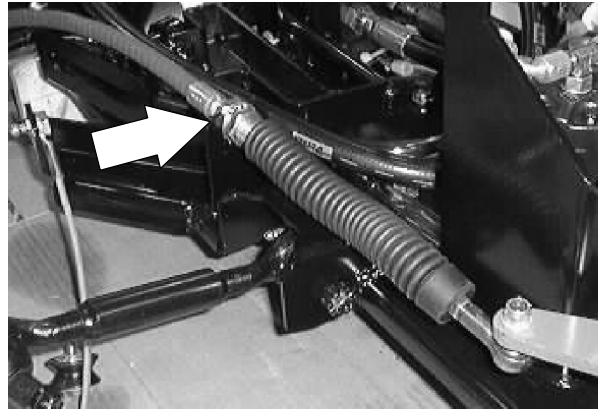

6. Remove the nut holding the cable balljoint to the side squeegee pivot bracket. Pull the pivot cable out of the slot. Remove the cable from the machine.

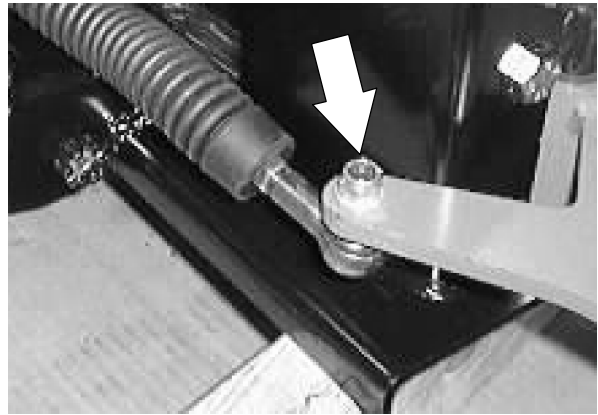

7. Remove the two balljoints and jam nuts from the old cable and install on the new cable. Turn the balljoints all the way on. Tighten the jam nuts.

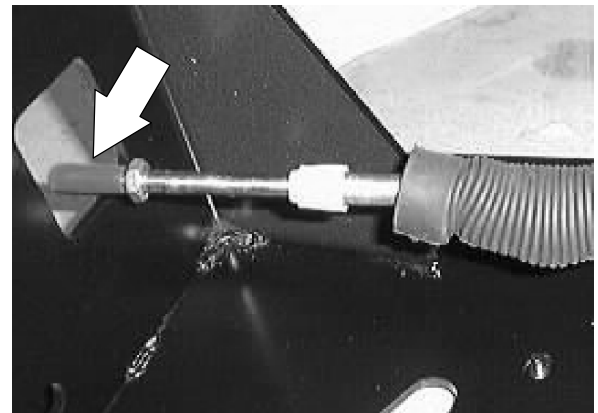

8. Install one end of the cable in the slot of the solution valve mount bracket.

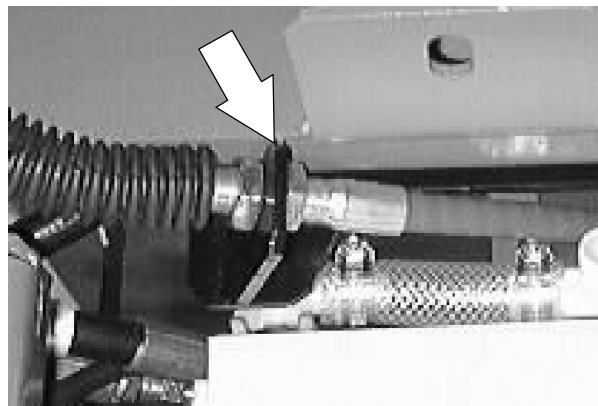

9. With the squeegee raised and the balljoint installed in the pivot bracket, the distance between the center of the ball joint and the center of the slotted tab on the solution valve mount bracket should be 10.16 inches.

*NOTE: Install the push-pull cable so there is 2-3/16 inch from the center of the bracket to the end of the cable steel area.*

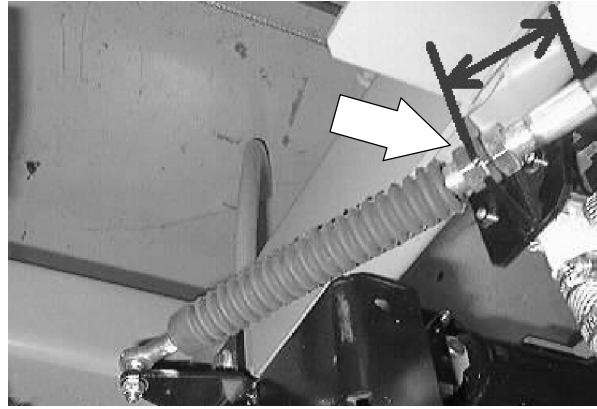

10. Reinstall the solution valve mount bracket onto the machine frame. Tighten the screws to 18 - 24 Nm (15 - 20 ft lb).

*NOTE: Make sure the rear squeegee is centered and both side squeegees are pointed slightly out (2°).*

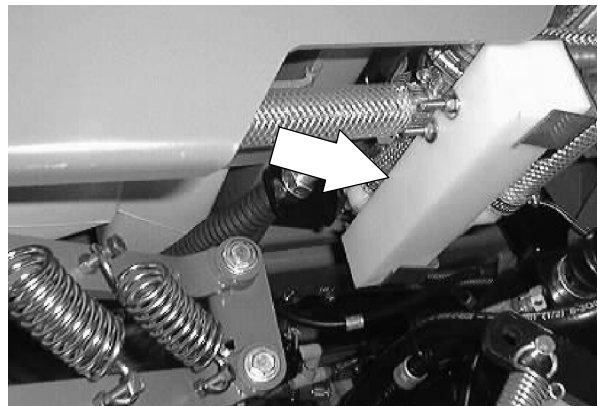

11. Install the other end of the shift cable into the slot on the mount bracket on the left side of the scrub head. Leave the cable jam nuts loose for now.

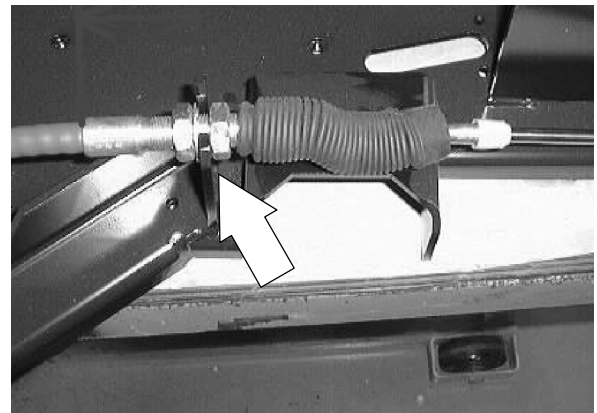

12. Install the cable balljoint and nut in the mount hole of the left side squeegee pivot bracket.

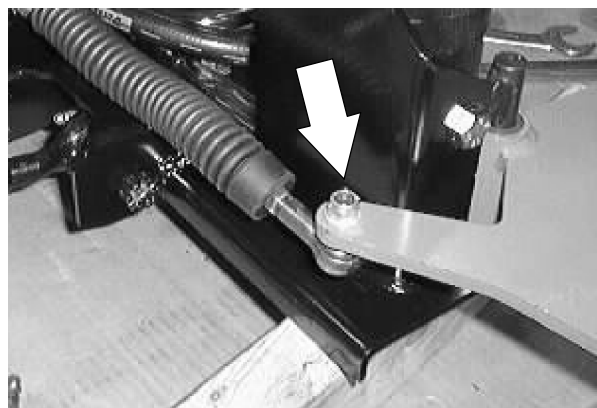

## SCRUBBING

13. The distance between the center of the balljoint and the center of the bracket on the scrub head should be 10.64 inches. Tighten the jam nuts.

*NOTE: Install the push-pull cable so there is 2-3/16 inch from the center of the bracket to the end of the cable steel area.*

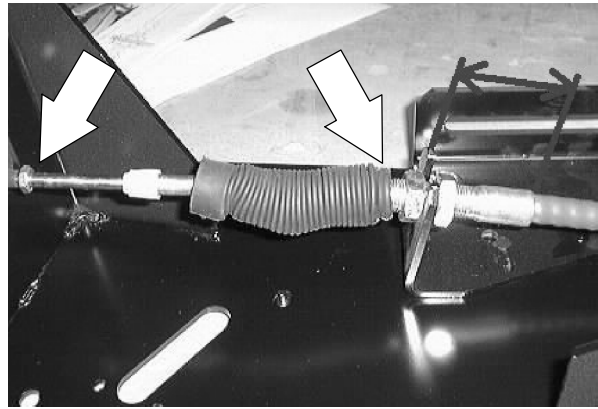

14. Lower the rear squeegee and scrub head. Drive forward to center the the rear squeegee on the scrub path (*rear squeegee is offset in the raised position*).

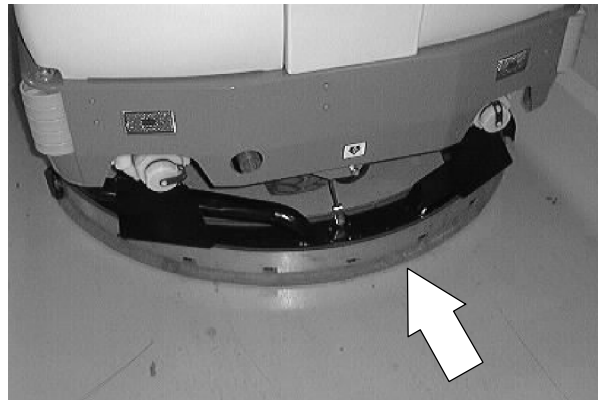

15. The left side squeegee tip should be pointed out approx. 2°. If is not--adjust the cable at the scrub head--NOT at the balljoint.

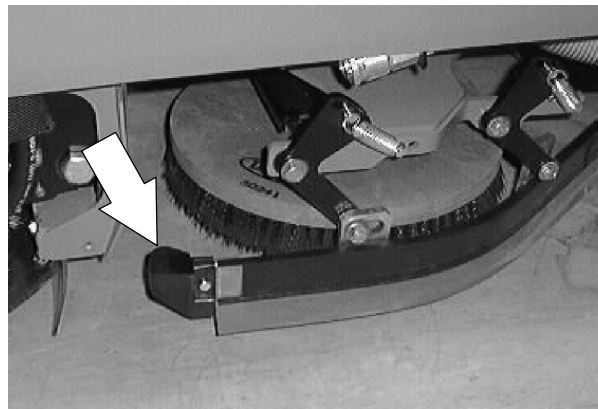

16. Make sure the balljoint on the cross rod to the right side squeegee is at the bottom of the slot.

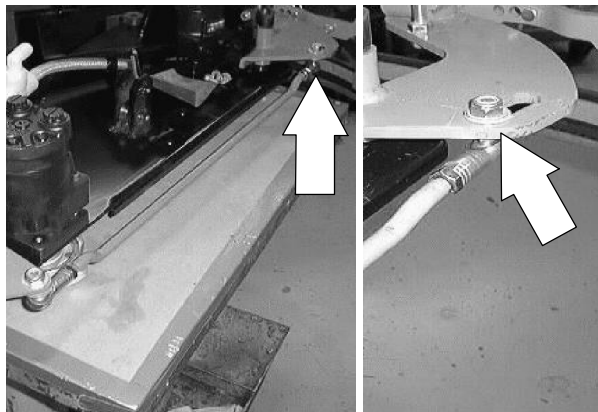

17. Operate the machine. Check the side squeegees for proper tracking of the rear squeegee--adjust if necessary.

**REAR SQUEEGEE**

The rear squeegee assembly channels water into the vacuum fan suction. The front squeegee blade channels the water, and rear blade wipes the floor. Check the rear squeegee assembly for damage, wear, and adjustment daily.

Rotate or replace either squeegee blade if its leading edge is torn or worn half-way through the thickness of the blade.

Each blade has four wiping edges. To use them all, start with one wiping edge. To use the next wiping edge, rotate the squeegee end-for-end. To use the next wiping edge, rotate the top edges down, bottom edges up. To use the last edge, rotate the squeegee end-for-end.

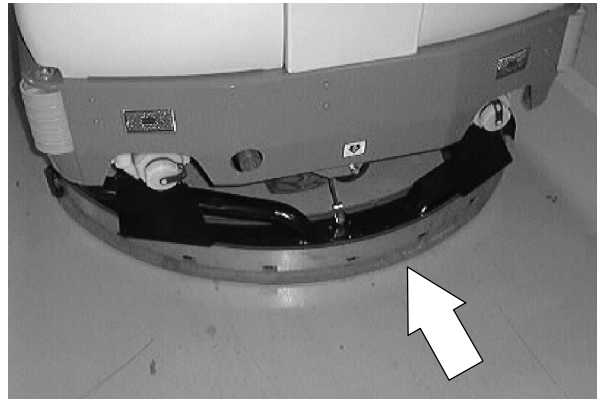

**TO REPLACE OR ROTATE REAR SQUEEGEE BLADES**

1. Make sure the rear squeegee is in the raised position.

**FOR SAFETY: Before Leaving Or Servicing Machine; Stop On Level Surface, Set Parking Brake.**

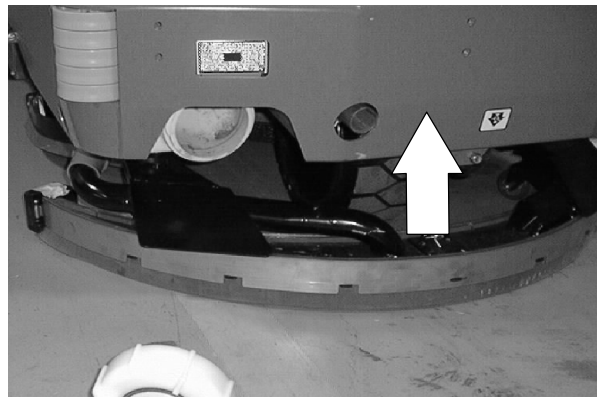

2. Pull back on the end of the squeegee blade lock latch.

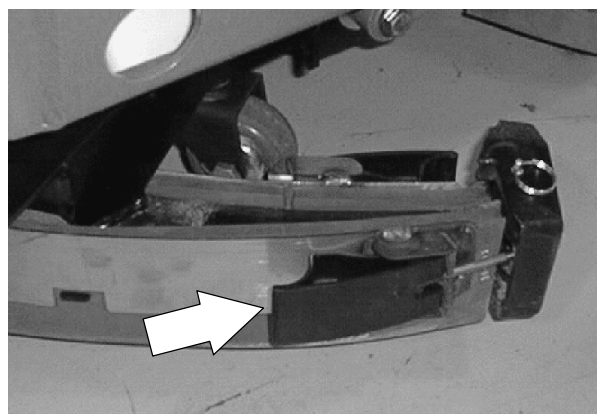

## SCRUBBING

3. Remove the retainer strap from the back squeegee blade.
4. Remove the squeegee blade from the squeegee frame.
5. Rotate the squeegee blade to a new edge.

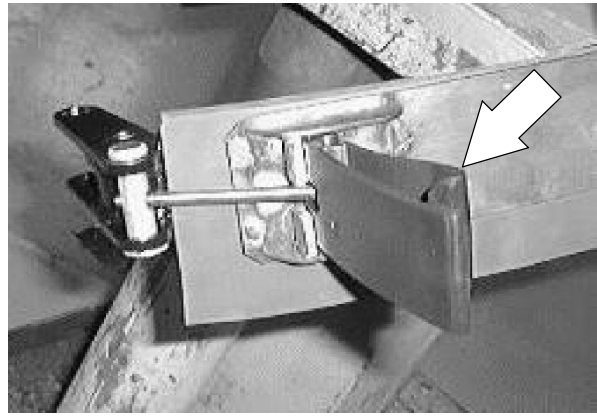

6. Reinstall the squeegee blade on the squeegee frame.

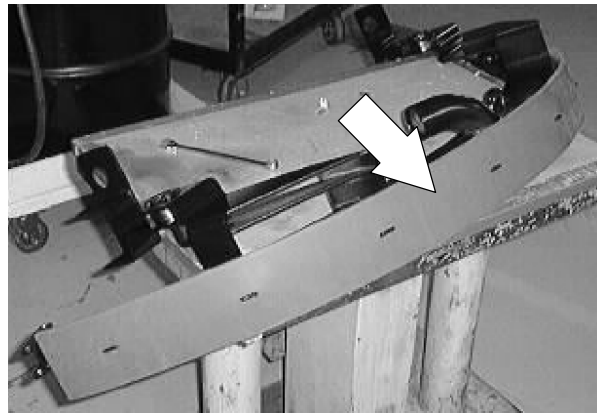

7. Reinstall the retainer strap.

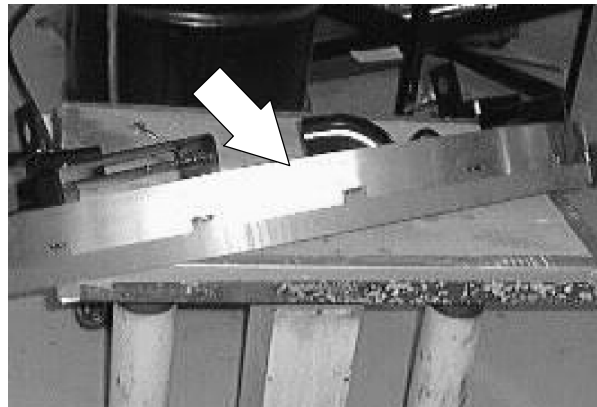

8. Push down on the end of the squeegee blade lock latch to lock the retainer and blade in place.

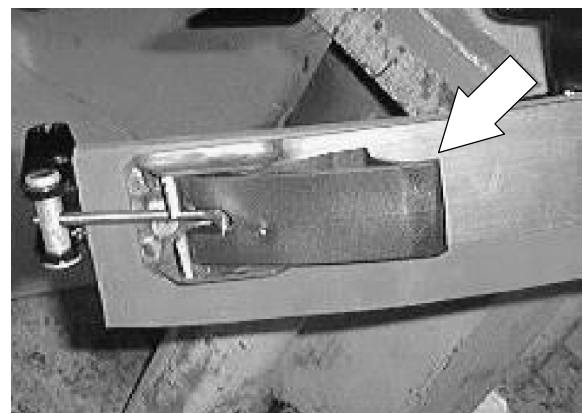



**TO ADJUST REAR SQUEEGEE ROLL-OUT**

1. Start the machine and lower the rear squeegee. Pull forward slightly and engage the parking brake. Shut off the machine.

**FOR SAFETY: Before Leaving Or Servicing Machine; Stop On Level Surface, Set Parking Brake.**

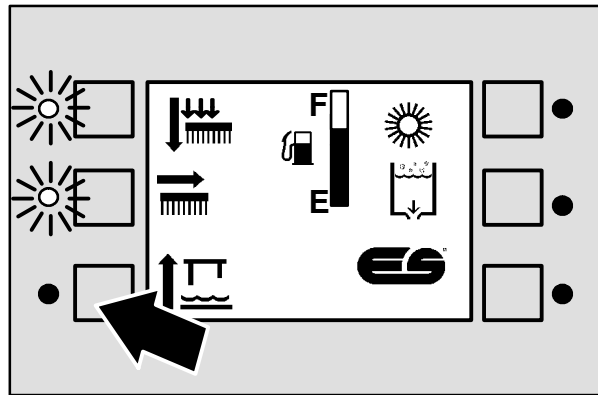

2. Go to the back of the machine and check the rear squeegee for even blade deflection across the entire blade.
3. If the squeegee blade roll-out is uneven or if the blade is too vertical or flattened out too much--go to the next step.

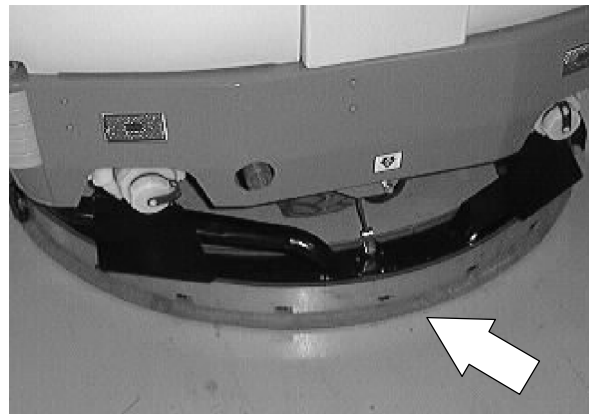

4. Loosen the large plastic jam nuts on the squeegee casters. Turn the casters down so they contact the floor evenly.

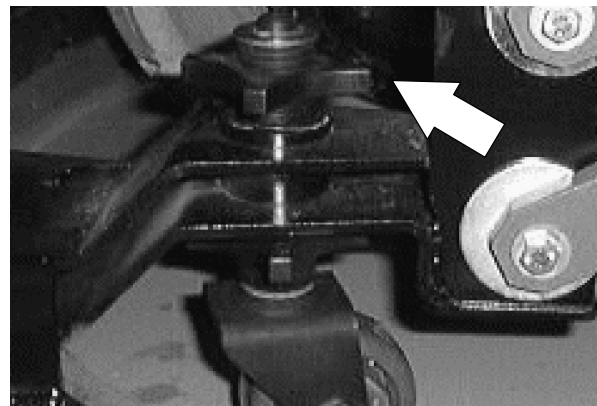

5. The bottom caster knob has four "tang"s. Adjust each caster OFF the floor **FIVE** "tang"s.

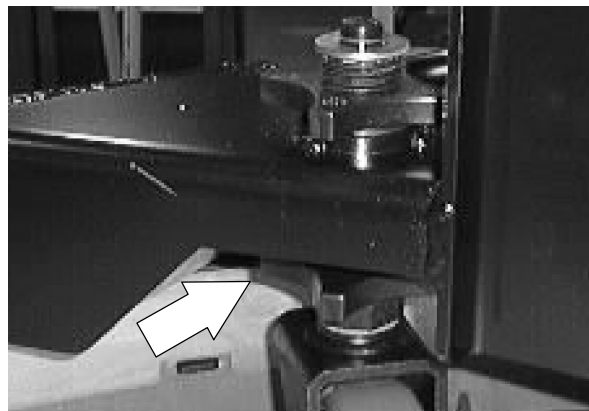

## SCRUBBING

6. Go back and tighten the locking (top) knob.

*NOTE: Make sure you hold the bottom knob from turning.*

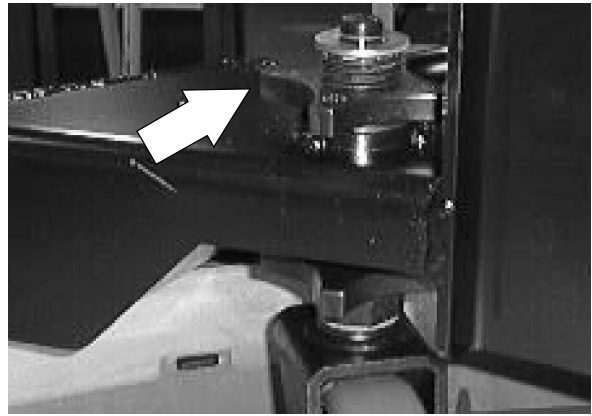

7. Start the machine and raise the rear squeegee.
8. Lower the rear squeegee and propel forward, checking for proper squeegee blade roll-out. If needed, adjust the casters evenly in 1/2 "tang" increments. *(this is touchy and may have to be done more than once)*
9. Re-adjust the rear casters anytime the rear squeegee levelness is adjusted.

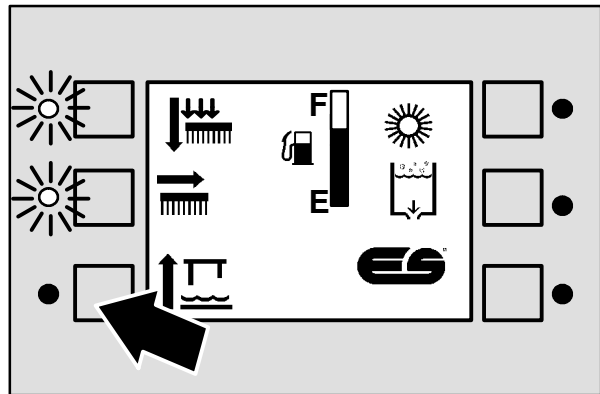

**TO LEVEL REAR SQUEEGEE**

1. Start the machine and lower the rear squeegee.

**FOR SAFETY: Before Leaving Or Servicing Machine; Stop On Level Surface, Set Parking Brake.**

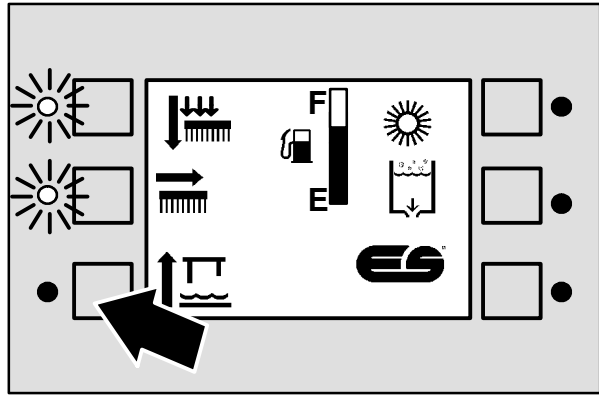

2. Go to the back of the machine and check the rear squeegee for even deflection across the entire blade.
3. If either side of the squeegee has more blade deflection than the other--an adjustment should be made. Go to the next step.

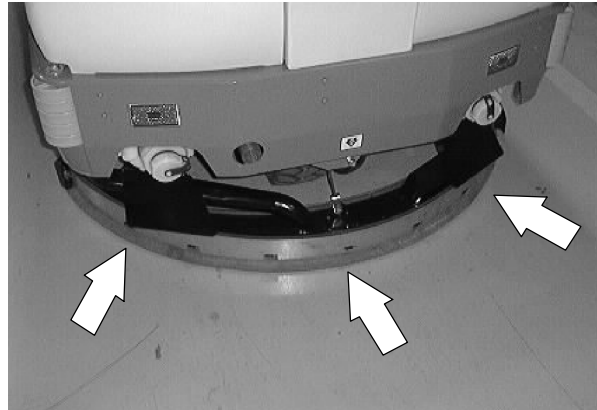

4. Raise the rear squeegee. Loosen the large plastic jam nuts on the squeegee casters. Turn the casters up at least 2 or 3 turns--until the casters no longer come in contact with the floor.

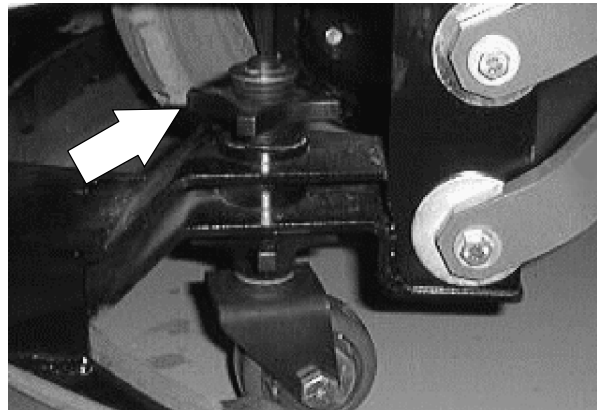

5. Start the machine and lower the rear squeegee.

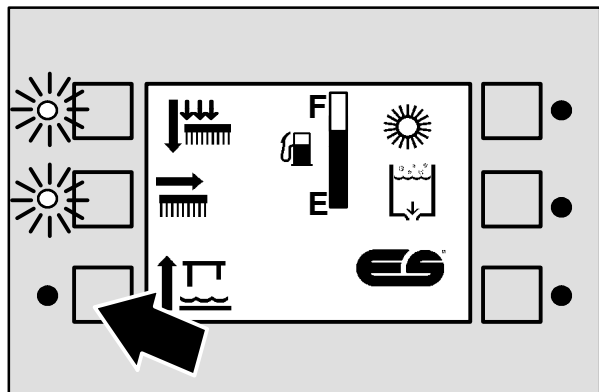

## SCRUBBING

6. Loosen the adjustment cam hex screw on the outside of the upper squeegee link--at the squeegee frame.

*NOTE: DO NOT over loosen--just enough to allow cam adjustment.*

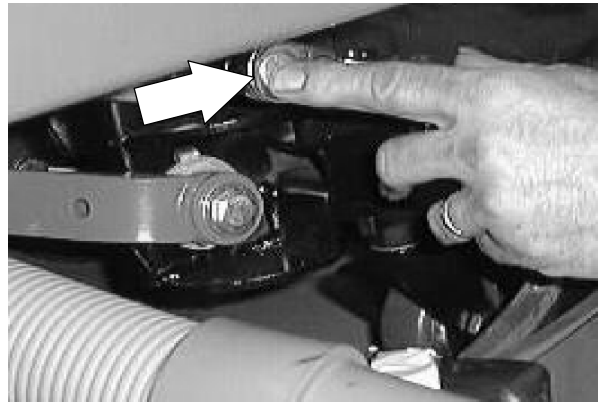

7. On the top of the adjusting cam, there is a machined groove. Using a 13mm socket, adjust the cam until it is rotated slightly towards the back of the machine (11:30 o'clock).



8. Hold the adjusting cam with the 13mm wrench as you tighten the 17mm bolt head. Repeat this procedure on both sides.

9. Once the squeegee has been properly leveled, tighten the adjustment cam hex screw.

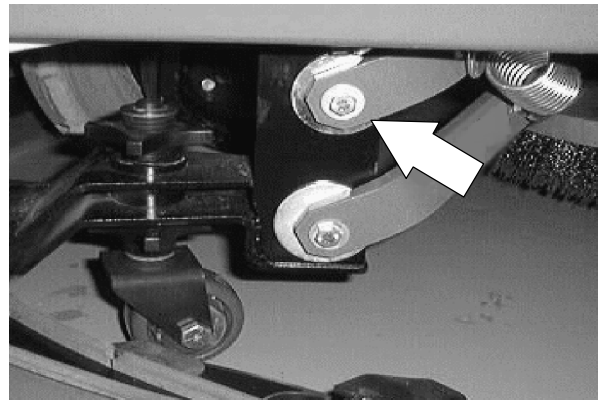

10. Turn the casters back down until they just touch the floor.

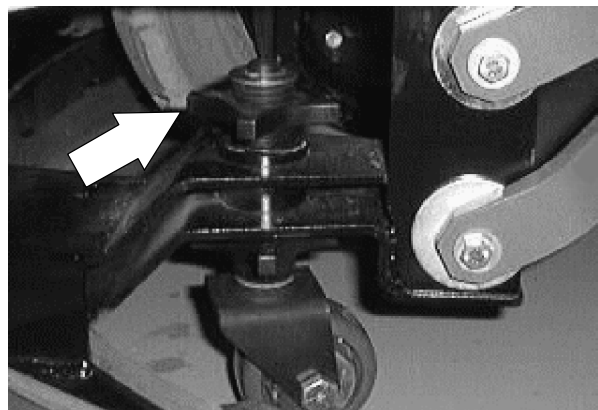

- The bottom caster knob has four “tangs”. Adjust each caster OFF the floor **FIVE** “tangs”

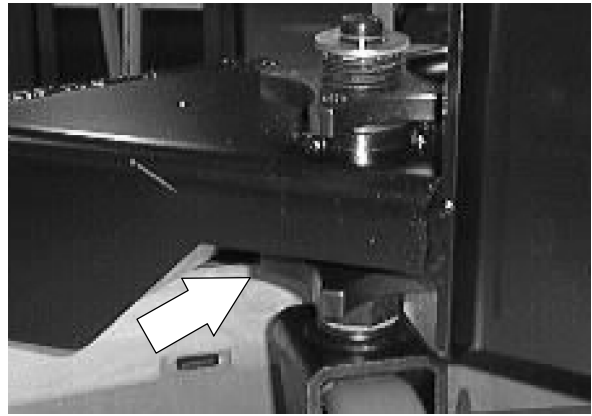

- Go back and tighten the locking (top) knob.

*NOTE: Make sure you hold the bottom knob from turning.*



- Start the machine and raise the rear squeegee.

- lower the rear squeegee and propel forward, checking for proper squeegee blade roll-out and levelness.

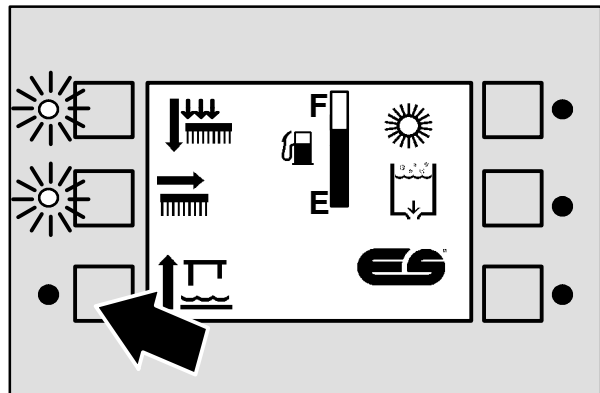

## SCRUBBING

### FINE TUNING REAR SQUEEGEE LEVELNESS

Lift and lower the squeegee assembly by grabbing onto the squeegee near the drain caps.

Verify that the rear blade has even pressure across its entire length by pushing the blade toward the front of the machine at various places along its length with your finger.

The blade should “pucker” and hold its distortion equally at each point. If it does not, you will have to fine tune the squeegee adjustment.

What you will want to keep an eye on is the relationship of the rear blade to the floor at both the tip and the middle of the blade.

Putting down pressure (rotating the cam toward the **rear** of machine) with the 13mm socket, loads the middle of the squeegee blade (this is normally what is required)

Putting down pressure (rotating the cam toward the **front** of machine) with the 13mm socket, loads the tips of the rear squeegee.

Again, make sure to hold the cam in position (with pressure) while tightening the bolt. Repeat on both sides and verify the pressure of the blade to the floor.

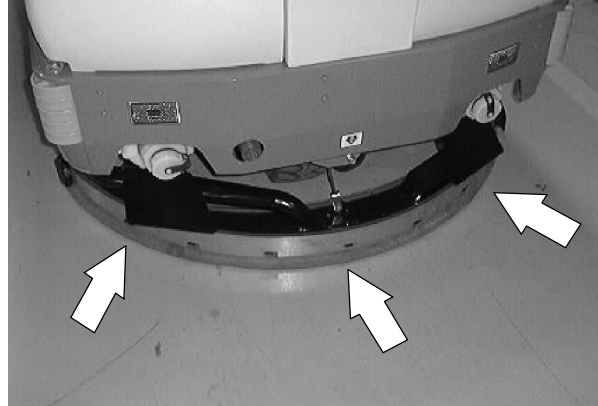

**TO REPLACE REAR SQUEEGEE LIFT CABLE**

1. Start the machine and lower the rear squeegee. Shut off the machine.

**FOR SAFETY: Before Leaving Or Servicing Machine; Stop On Level Surface, Set Parking Brake.**

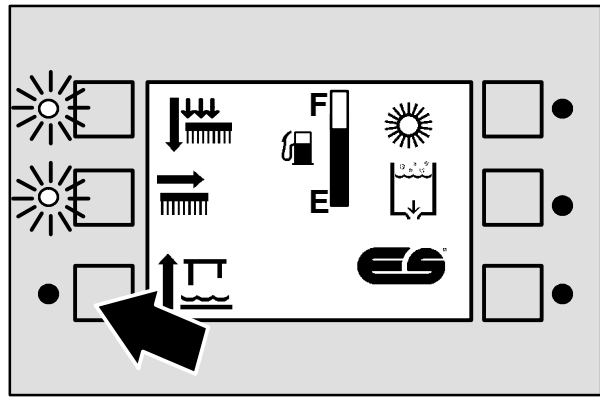

2. Pull the vacuum hose off the tube on the squeegee frame.

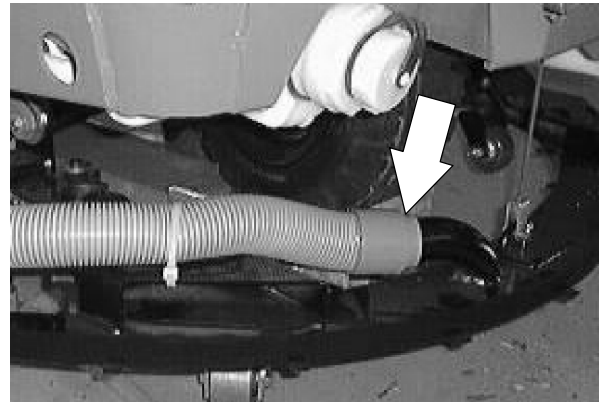

3. Remove the hair pin and clevis pin holding the lower clevis on the squeegee lift cable to the squeegee frame.



4. Remove the long hex screw holding the upper clevis on the squeegee lift cable to the machine frame. Note the routing of the old lift cable and remove it from the machine.

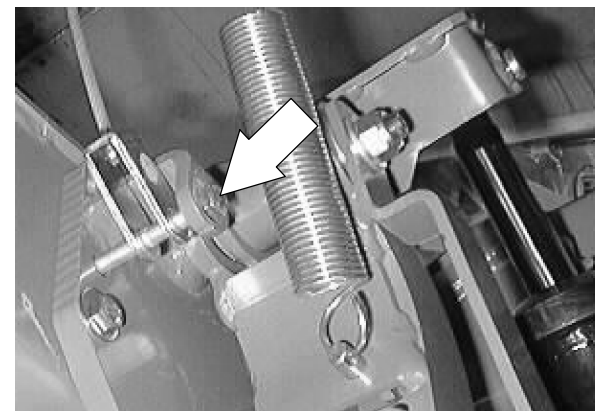

## SCRUBBING

5. Install the new squeegee lift cable in the machine. Make sure to route the new cable the same way the old one was routed.

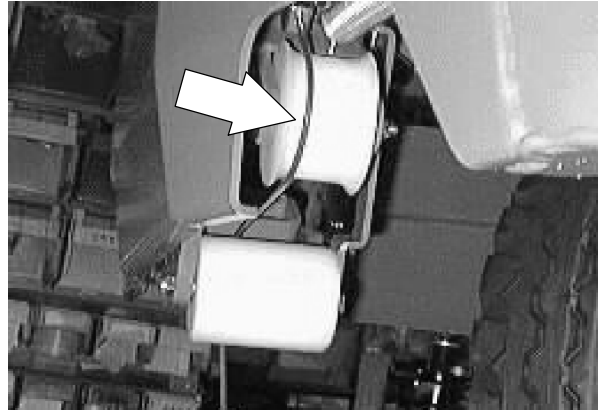

6. Install the long hex screw in the upper clevis of the new lift cable. Tighten to 18 - 24 Nm (15 - 20 ft lb).

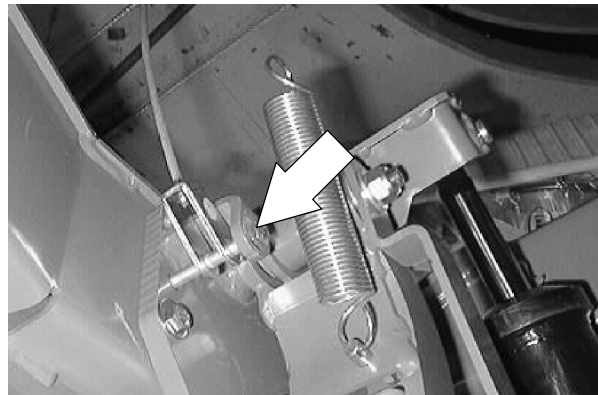

7. Install the clevis pin and hair pin the lower clevis of the new cable and squeegee frame.

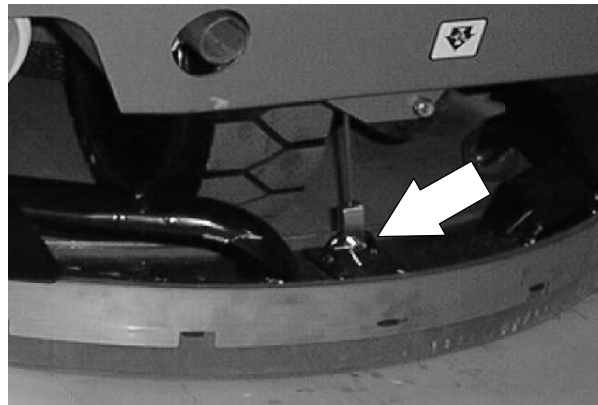

8. Plug the vacuum hose onto the tube on the squeegee frame.

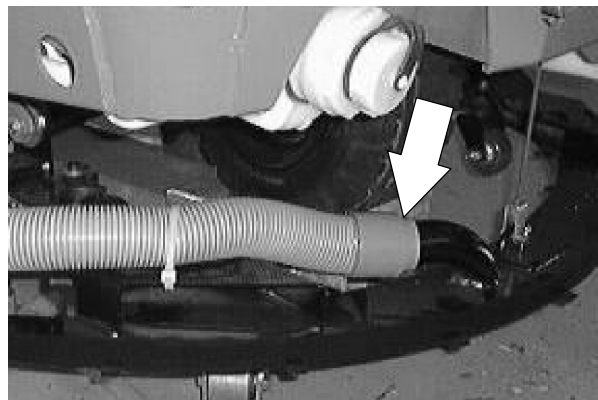

9. Start the machine and operate the rear squeegee. Check for proper operation of the new cable.



**TO REMOVE REAR SQUEEGEE FRAME**

1. Start the machine and lower the rear squeegee. Shut off the machine.

**FOR SAFETY: Before Leaving Or Servicing Machine; Stop On Level Surface, Set Parking Brake.**

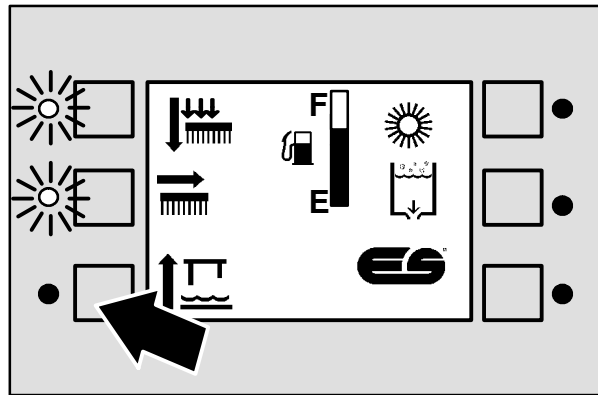

2. Raise the rear of the machine and install jack stands under the machine frame.

**FOR SAFETY: Block machine tires before jacking machine up. Jack machine up at designated locations only. Block machine up with jack stands.**



3. Pull the vacuum hose off the tube on the squeegee frame.

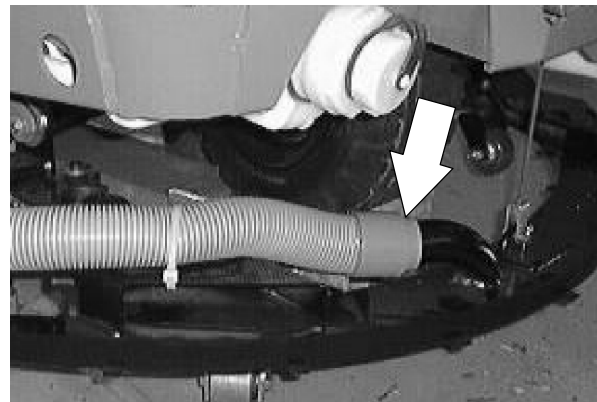

4. Remove the hair pin and clevis pin holding the lower clevis on the squeegee lift cable to the squeegee frame.

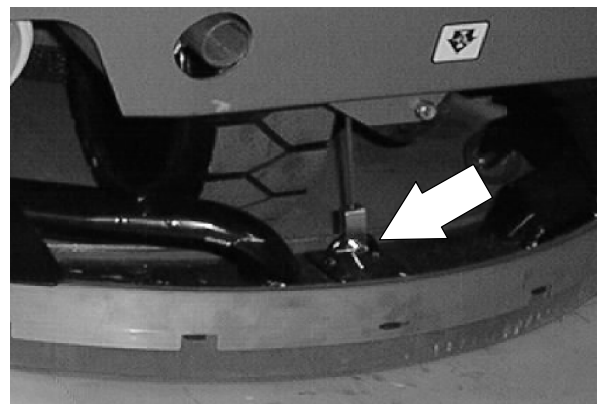

## SCRUBBING

5. Use a vise grip or channel lock to remove the four down pressure tension springs from the squeegee links.

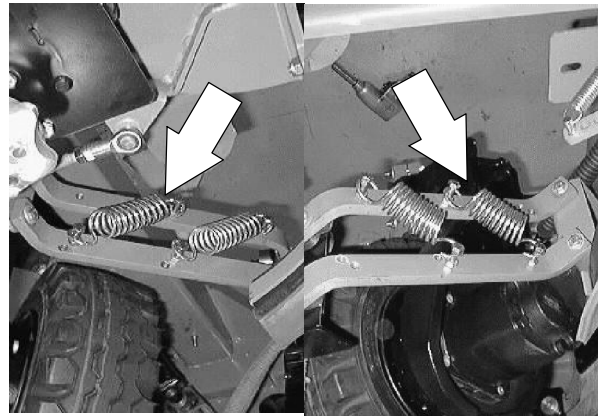

6. Remove the hex screws and nuts holding the squeegee links to the squeegee frame.

*NOTE: Make sure to pay close attention to the order of hardware assembly. The proper re-assembly of the adjustment cams on the upper squeegee links is very important.*

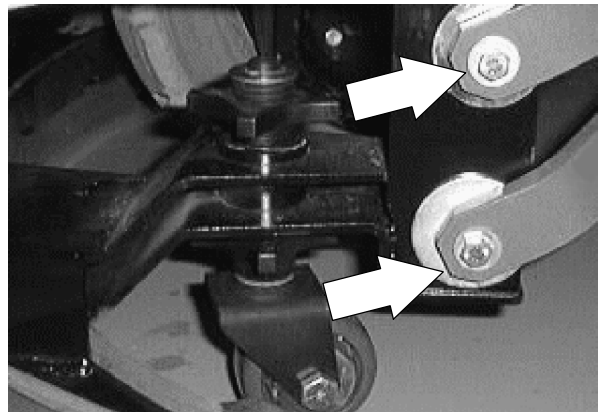

7. Remove the squeegee frame from the machine.



**TO INSTALL REAR SQUEEGEE FRAME**

**FOR SAFETY: Before Leaving Or Servicing Machine; Stop On Level Surface, Set Parking Brake.**

1. Raise the rear of the machine and install jack stands under the machine frame.

**FOR SAFETY: Block machine tires before jacking machine up. Jack machine up at designated locations only. Block machine up with jack stands.**



2. Position the squeegee frame under the rear of the machine.



3. Line up the mount holes in the squeegee frame with the mount holes in the end of the four squeegee connecting links on the machine.

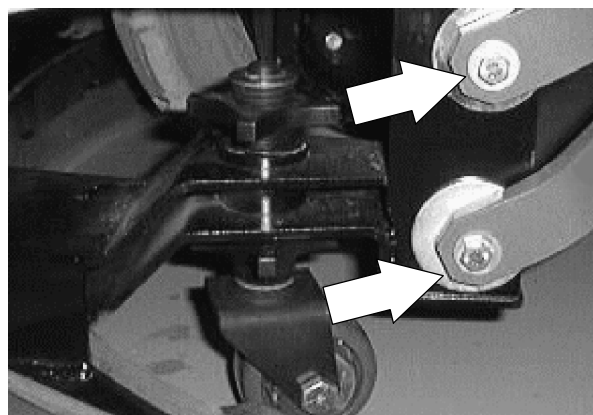

## SCRUBBING

4. Install the hardware and sleeves in the two lower squeegee links. Leave the hardware loose for now.

*NOTE: Make sure to pay close attention to the order of hardware assembly. The proper re-assembly of the adjustment cams on the upper squeegee links is very important.*

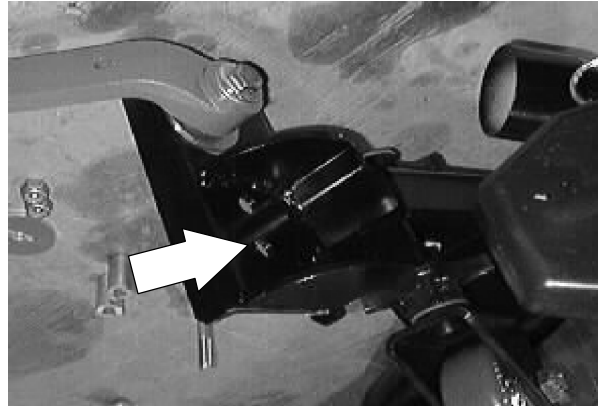

5. Install the squeegee level adjustment cams and washers in the two upper squeegee links. Tighten all of the hardware to 37 - 48 Nm (26 - 34 ft lb).



6. Reinstall the four down pressure tension springs onto the squeegee links.

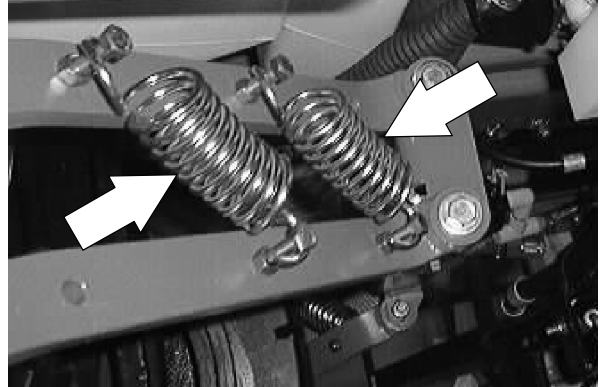

7. Reconnect the squeegee lift cable to the squeegee frame. Reinstall the clevis and hair pin.

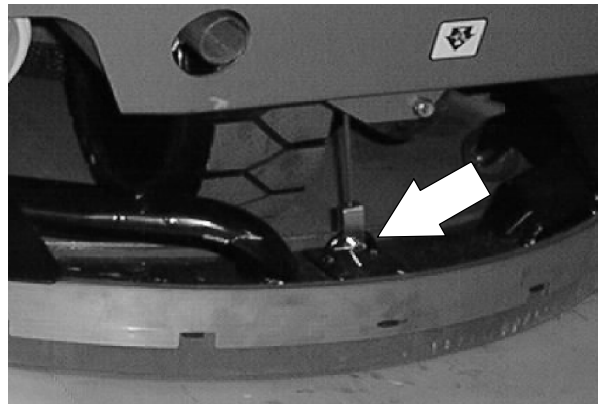

8. Plug the vacuum hose into the tube on the squeegee frame.

9. Operate the machine and check the rear squeegee for proper operation. See TO LEVEL REAR SQUEEGEE instructions if needed.

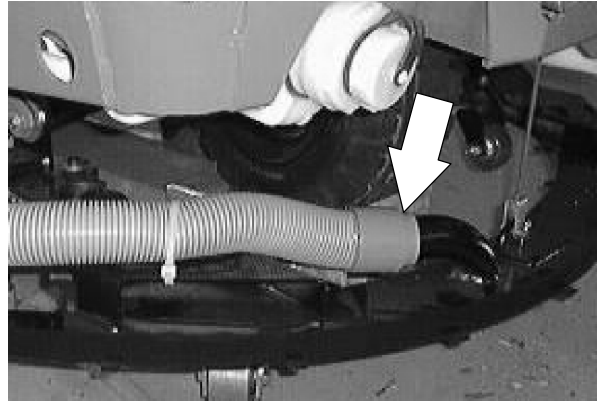

## SCRUBBER VACUUM FAN

The scrubbing vacuum fan, when activated, creates a vacuum in the recovery tank. The recovery tank is sealed to the tank cover when it is in the down position. Water is pulled from the rear squeegee to the recovery tank through a vacuum hose.

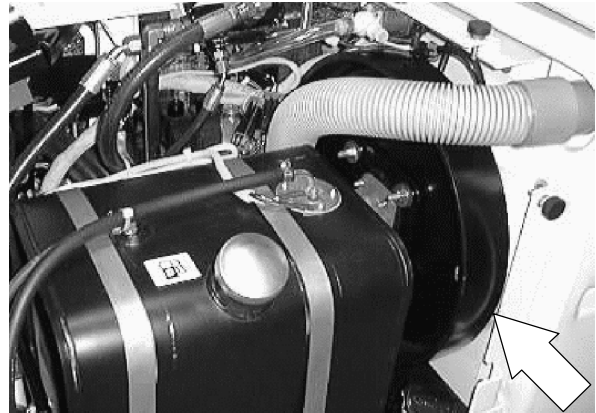

### TO REMOVE SCRUBBER VACUUM FAN ASSEMBLY

**FOR SAFETY: Before Leaving Or Servicing Machine; Stop On Level Surface, Set Parking Brake.**

1. Open the engine cover and side door.

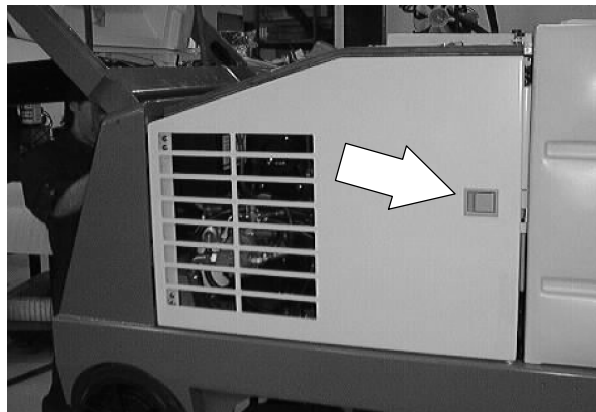

2. Disconnect the battery.

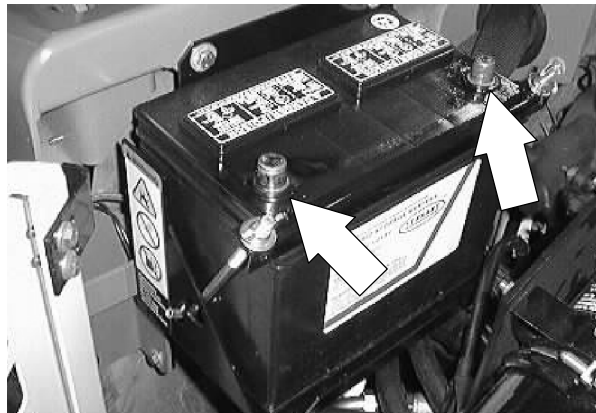

3. Pull the vacuum hose out of the recovery tank.

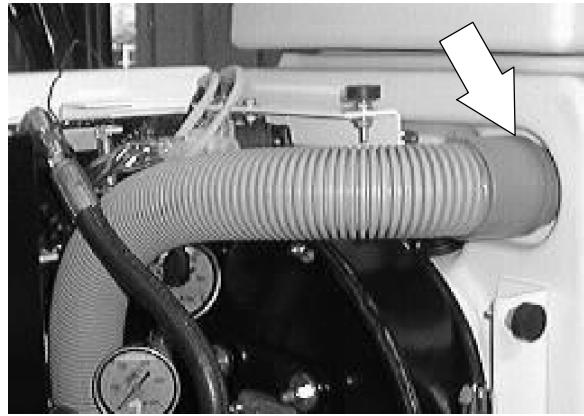

4. LP MACHINE: Disconnect the LP tank and remove it from the machine.

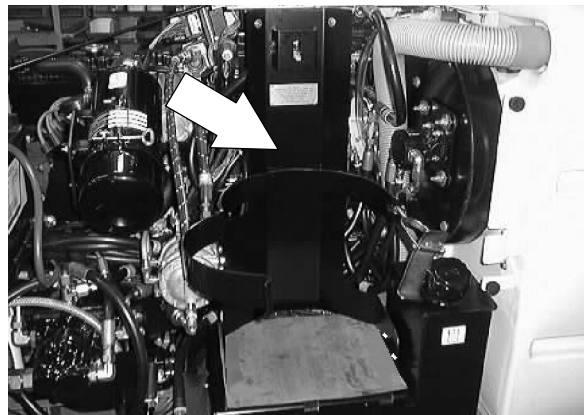

5. GAS/DIESEL MACHINE: Remove the two wires and two rubber hoses from the top of the fuel tank. Remove the nut from the outside end of both tank straps. Remove the fuel tank.

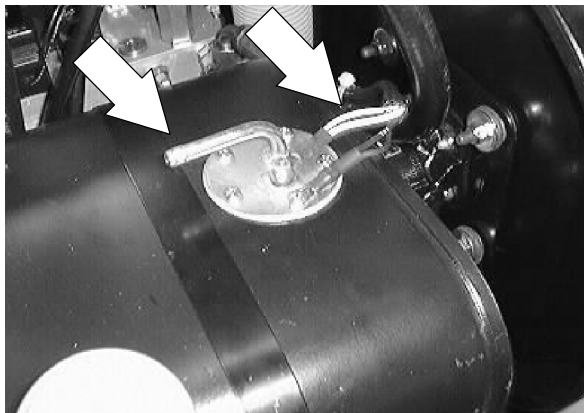

6. Mark, disconnect, and plug the three hydraulic hoses leading to the scrubbing vacuum fan.

*NOTE: Make sure to note the orientation of the vacuum fan on the recovery tank for proper re-assembly.*

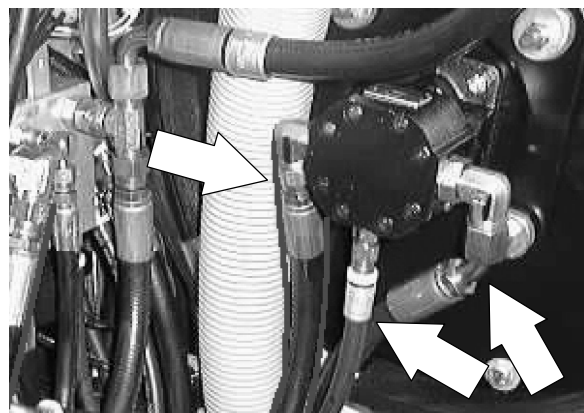

## SCRUBBING

7. Remove the four hex screws holding the scrubbing vacuum fan to the recovery tank.

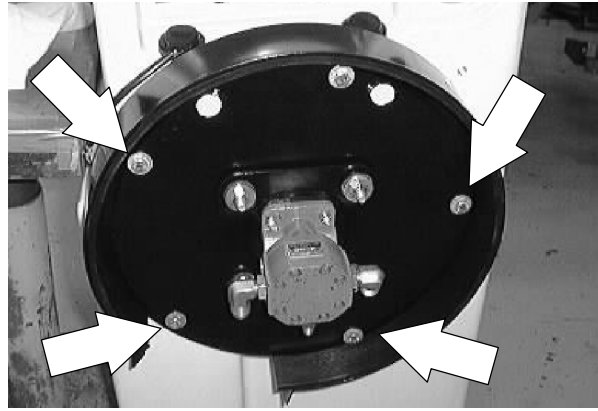

8. Remove the vacuum fan from the machine.

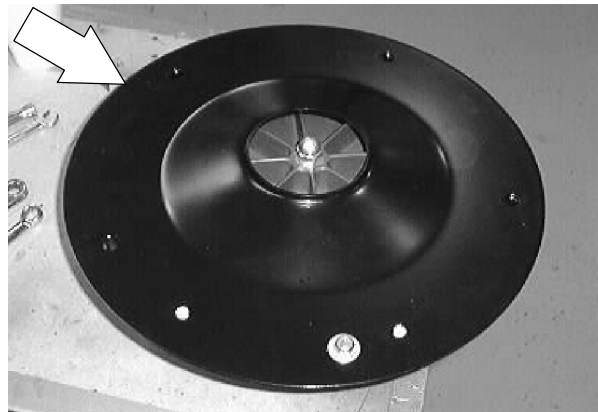



## TO INSTALL SCRUBBER VACUUM FAN ASSEMBLY

**FOR SAFETY: Before Leaving Or Servicing Machine; Stop On Level Surface, Set Parking Brake.**

1. Open the engine cover and side door.



2. Disconnect the battery.

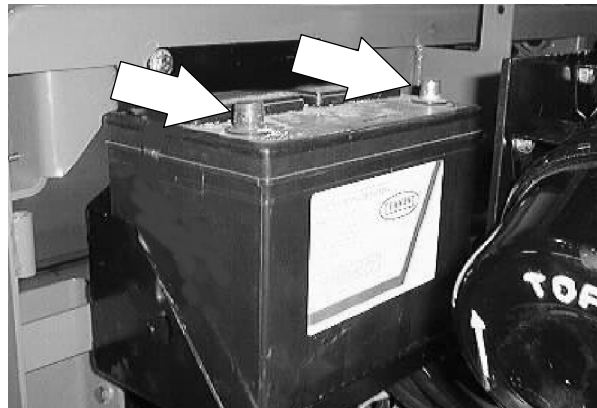

3. Position the scrubber vacuum fan on the front of the recovery tank.

*NOTE: Make sure the vacuum fan assembly is installed on the recovery tank with the fittings on the hydraulic motor orientated in the proper direction.*

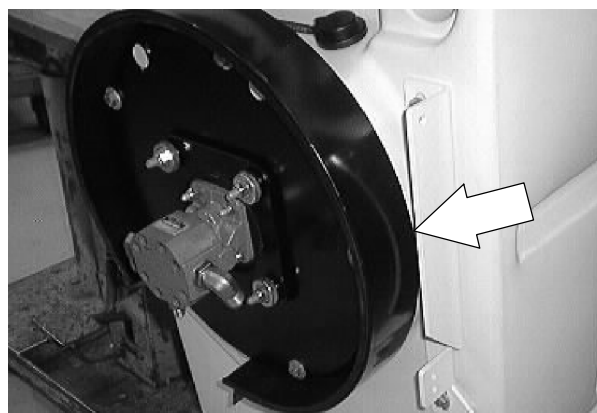

## SCRUBBING

4. Install the four vacuum fan mount screws and tighten to 18 - 24 Nm (15 - 20 ft lb).

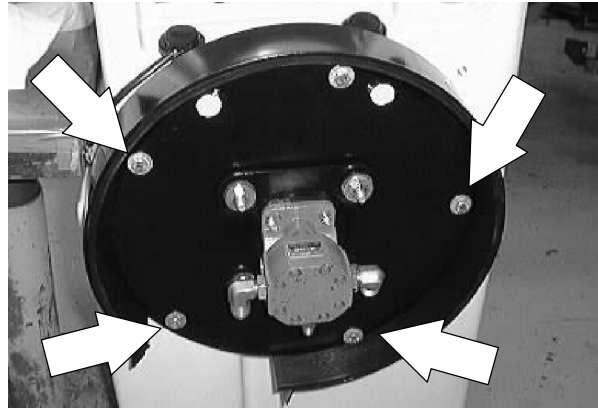

5. Reconnect the three hydraulic hoses to the vacuum fan motor. See schematic in the HYDRAULICS section.

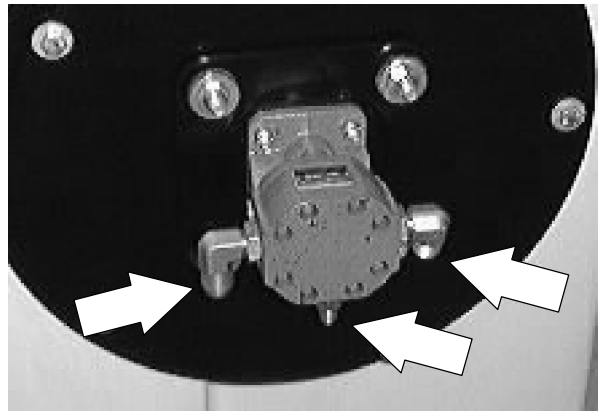

6. LP MACHINE: Reinstall the LP tank and connect the LP hose.

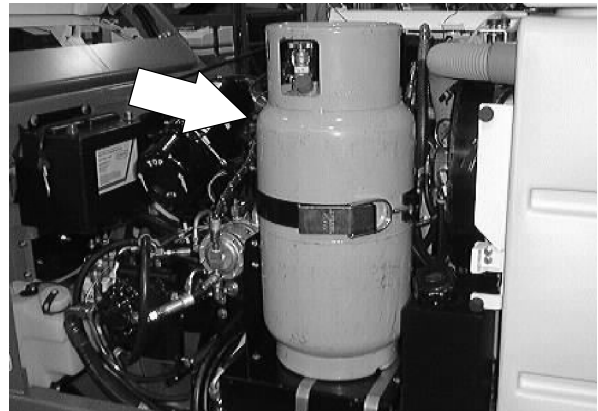

7. GAS/DIESEL MACHINE: Reinstall the fuel tank in the machine. Reinstall the nut on the out side end of both tank straps. Hand tighten tight. Reinstall the two wires and two rubber hoses to the top of the fuel tank.

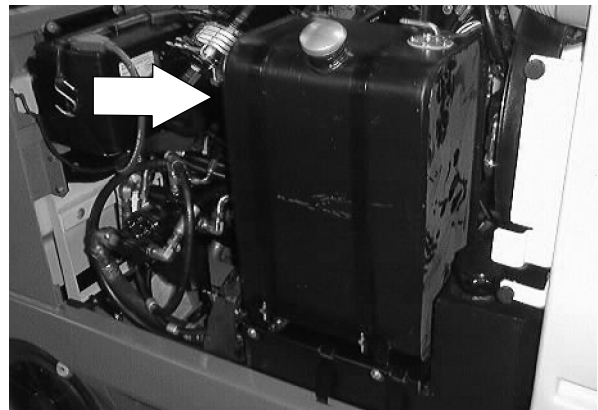

8. Reinstall the vacuum hose into the front of the recovery tank.

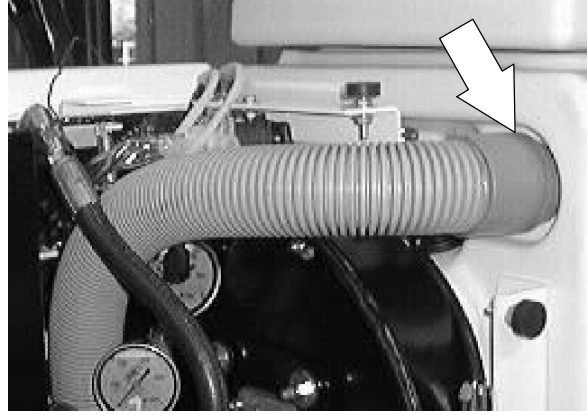

9. Reconnect the battery.

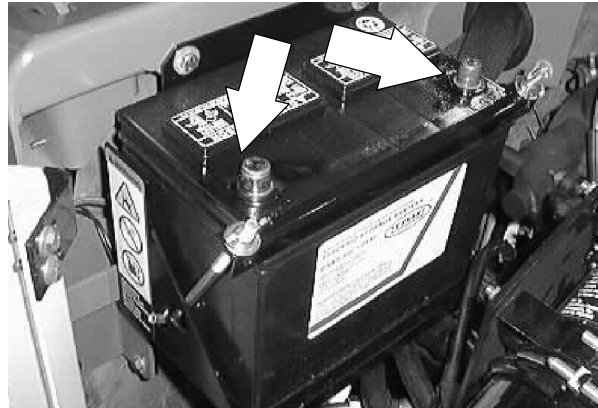

10. Close the engine cover and side door.

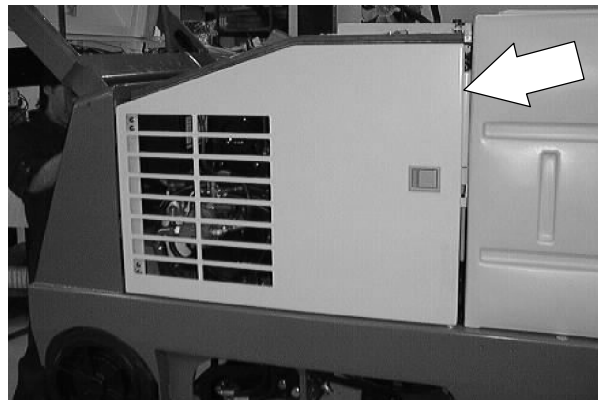

11. Start the machine and operate the scrubbing system. Check the scrubbing vacuum fan for proper operation.

# SCRUBBING

## MACHINE SCRUBBING TROUBLESHOOTING

*NOTE: Also see trouble shooting charts in the ELECTRICAL section.*

<b>Problem</b>	<b>Cause</b>	<b>Remedy</b>
Trailing water – poor or no water pickup	Worn rear squeegee blades.	Rotate or replace squeegee blades.
	Rear squeegee out of adjustment.	Adjust rear squeegee.
	Side squeegees raised.	Lower side squeegees.
	Worn side squeegee blades.	Replace side squeegee blades.
	Hopper not adjusted properly.	Adjust hopper floor clearance.
	Side squeegees out of adjustment.	Adjust side squeegees.
	Too much solution flow to floor.	Reduce solution flow to floor.
	Vacuum hose clogged.	Flush vacuum hoses.
	Recovery tank full.	Drain recovery tank.
	Float stuck shutting off vacuum.	Clean float.
	Debris caught on rear squeegee.	Remove debris.
	Foam filling recovery tank.	Empty recovery tank; use less or change detergent.
	Vacuum hose to rear squeegee disconnected or damaged.	Reconnect or replace vacuum hose.
Only one vacuum fan operating	Check and reset circuit breaker	
Trailing water – poor or no water pickup	Vacuum fan to recovery tank hose damaged.	Replace hose.
Little or no solution flow to the floor	Solution tank empty.	Fill solution tank.
	Solution control linkage broken or out of adjustment.	Replace and/or adjust cable.
	Solution supply lines plugged.	Flush solution supply lines.
	ES™ switch off.	Turn ES™ switch on.
Poor scrubbing performance	Debris caught on scrub brushes.	Remove debris.
	Improper detergent or brushes used.	Check with TENNANT representative for advice.
	Worn scrub brushes.	Replace scrub brushes.
ES™ system does not fill solution tank	Clogged solution pump or lines.	Flush ES™ system.
	ES™ float switches stuck.	Clean switch floats of debris.
	Clogged ES™ outlet filter.	Clean filter.
	Water levels too low in tanks.	Add water.

## CONTENTS

	Page		Page
INTRODUCTION .....	5-3	RECOVERY TANK AUTOFILL	
BATTERY .....	5-4	VALVE DISABLED .....	5-55
TO REPLACE BATTERY .....	5-6	SOLUTION TANK AUTOFILL	
INSTRUMENT PANEL .....	5-8	VALVE ENABLED .....	5-55
TO REPLACE INDICATOR LIGHT .....	5-8	SOLUTION TANK AUTOFILL	
TO REPLACE TOUCH PANEL .....	5-11	VALVE DISABLED .....	5-55
TO REPLACE ELECTRICAL RELAY .....	5-14	NORMAL MODE (front panel) .....	5-56
CIRCUIT BREAKERS .....	5-17	EDGE SCRUB BUTTON .....	5-56
FUSE (DIESEL ONLY) .....	5-17	SQUEEGEE .....	5-56
TO REPLACE CIRCUIT BREAKER .....	5-18	ENGINE SPEED .....	5-56
TO REPLACE GLOW PLUG FUSE .....	5-21	SCRUB .....	5-57
TO REPLACE GLOW PLUG TIMER .....	5-23	DETERGENT .....	5-58
TO REPLACE FILTER SHAKER MOTOR .....	5-25	ES™ .....	5-58
THERMO SENTRY™ .....	5-28	OVER-FLOW .....	5-59
TO REPLACE THERMO SENTRY™ .....	5-28	NORMAL MODE (side panel) .....	5-59
TO REPLACE ES™ PUMP .....	5-30	MAIN SWEEP BRUSH .....	5-59
TO REPLACE DETERGENT PUMP .....	5-33	SIDE SWEEP BRUSH .....	5-59
ELECTRICAL SCHEMATIC .....	5-36	FILTER SHAKER .....	5-59
HOPPER WIRE HARNESS DIAGRAM .....	5-40	VACUUM FAN .....	5-60
MAIN WIRE HARNESS DIAGRAM .....	5-41	MAINTENANCE MODES .....	5-60
GAS/LP ENGINE WIRE HARNESS		MANUAL MODE .....	5-61
DIAGRAM (000000 - 006451) .....	5-49	INPUT DISPLAY MODE .....	5-63
GAS/LP ENGINE WIRE HARNESS		ERROR DISPLAY MODE .....	5-64
DIAGRAM (006452 - ) .....	5-50	PRESSURE ADJUST MODE .....	5-65
DIAGNOSTICS-8200 .....	5-51	RESET SCRUB PRESSURE .....	5-66
OPERATING MODES .....	5-52	DIAGNOSTICS-8210 .....	5-67
INTERLOCKS .....	5-53	OPERATING MODES .....	5-68
SCRUB BRUSH OPERATION		FRONT PANEL OPERATING MODES ..	5-69
ENABLED .....	5-53	FRONT PANEL MAINTENANCE	
SCRUB BRUSH OPERATION		MODES .....	5-70
INHIBITED .....	5-53	FRONT PANEL MAINTENANCE	
SQUEEGEE AND VACUUM FAN		MODES .....	5-71
OPERATION ENABLED .....	5-53	INTERLOCKS .....	5-73
SQUEEGEE AND VACUUM FAN		SCRUB BRUSH OPERATION	
OPERATION INHIBITED .....	5-53	ENABLED .....	5-73
ES™ PUMP OPERATION ENABLED .....	5-53	SCRUB BRUSH OPERATION	
ES™ PUMP OPERATION INHIBITED .....	5-54	INHIBITED .....	5-73
SWEEP BRUSH OPERATION		SQUEEGEE AND VACUUM FAN	
ENABLED .....	5-54	OPERATION ENABLED .....	5-73
SWEEP BRUSH OPERATION		SQUEEGEE AND VACUUM FAN	
INHIBITED .....	5-54	OPERATION INHIBITED .....	5-73
SWEEP FAN OPERATION		ES™ PUMP OPERATION ENABLED .....	5-74
ENABLED .....	5-54	ES™ PUMP OPERATION INHIBITED .....	5-74
SWEEP FAN OPERATION		SWEEP BRUSH OPERATION	
INHIBITED .....	5-54	ENABLED .....	5-74
SIDE BRUSH OPERATION		SWEEP BRUSH OPERATION	
ENABLED .....	5-54	INHIBITED .....	5-74
SIDE BRUSH OPERATION		SWEEP FAN OPERATION ENABLED .....	5-74
INHIBITED .....	5-54	SWEEP FAN OPERATION INHIBITED .....	5-74
ES™ AIR FLUSH OPERATION		SIDE BRUSH OPERATION ENABLED .....	5-75
ENABLED .....	5-55	SIDE BRUSH OPERATION	
ES™ AIR FLUSH OPERATION		INHIBITED .....	5-75
INHIBITED .....	5-55	ES™ AIR FLUSH OPERATION	
RECOVERY TANK AUTOFILL		ENABLED .....	5-75
VALVE ENABLED .....	5-55		

	Page		Page
ES™ AIR FLUSH OPERATION		INCORRECT ENGINE GOVERNED	
INHIBITED	5-75	SPEED OR RESPONSE	
SOLUTION TANK AUTOFILL		(8200/8210)	5-98
VALVE ENABLED	5-75	MAIN SWEEPING BRUSH WILL NOT	
SOLUTION TANK AUTOFILL		RUN (8200)	5-99
VALVE DISABLED	5-76	SIDE BRUSH WILL NOT RUN (8200)	5-100
RECOVERY TANK AUTOFILL		SWEEPING VACUUM FAN WILL	
VALVE ENABLED	5-76	NOT RUN (8200)	5-101
RECOVERY TANK AUTOFILL		FILTER SHAKER WILL NOT RUN	
VALVE DISABLED	5-76	(8200)	5-102
HOPPER DOOR BLOCKING		SCRUB BRUSHES WILL NOT RAISE	
VALVE ENABLED	5-76	OR LOWER (8200)	5-103
HOPPER DOOR BLOCKING		SCRUB BRUSHES WILL NOT	
VALVE DISABLED	5-76	TURN ON (8200)	5-104
DETERGENT PUMP ENABLED	5-77	SCRUB HEAD DOWN FORCE	
DETERGENT PUMP DISABLED	5-77	(SV-8) (8200)	5-105
BASIC 8210 OPERATION	5-77	SCRUB HEAD DOWN FORCE	
EDGE SCRUB (SCRUB, SWEEP/ SCRUB MODE)	5-77	(SV-8) (8200)-continued	5-106
SQUEEGEE (SCRUB, SWEEP/ SCRUB, SWEEP MODE)	5-77	SCRUB HEAD EDGE SCRUB WILL	
ENGINE SPEED (ALL MODELS)	5-78	NOT SHIFT (8200)	5-107
DETERGENT (SCRUB MODE)	5-79	SQUEEGEE WILL NOT LOWER	
ES™ (SCRUB MODE)	5-79	(8200)	5-108
OVERFLOW (SCRUB MODE, SWEEP/SCRUB MODE)	5-79	SCRUB VACUUM FAN WILL NOT	
MAIN SWEEP BRUSH		RUN (8200)	5-109
(SWEEP MODE, SWEEP/SCRUB MODE)	5-80	SOLUTION CONTROL WILL NOT	
SIDE SWEEP BRUSH		OPERATE (8200)	5-110
(SWEEP MODE, SWEEP/SCRUB MODE)	5-80	DETERGENT PUMP WILL NOT	
FILTER SHAKER	5-80	OPERATE (8200)	5-111
VACUUM FAN	5-81	ES™ WILL NOT OPERATE (8200)	5-112
MAINTENANCE MODES	5-82	MAIN SWEEPING BRUSH WILL	
MANUAL MODE	5-83	NOT RUN (8210)	5-113
INPUT DISPLAY MODE	5-85	SIDE BRUSH WILL NOT RUN (8210)	5-114
SELF TEST MODE	5-86	SWEEPING VACUUM FAN WILL	
PRESSURE ADJUST MODE	5-87	NOT RUN (8210)	5-115
SCRUB BUTTON	5-88	FILTER SHAKER WILL NOT RUN	
SQUEEGEE BUTTON	5-88	(8210)	5-116
UP ARROW	5-88	SCRUB BRUSHES WILL NOT	
DOWN ARROW	5-88	RAISE/LOWER (8210)	5-117
EXIT	5-88	SCRUB BRUSHES WILL NOT	
RESET SCRUB PRESSURE	5-89	TURN ON (8210)	5-118
SET CLOCK	5-90	SCRUB HEAD DOWN FORCE	
CHECK MAINTENANCE MODE	5-91	(SV-8) (8210)	5-119
TROUBLESHOOTING-8200/8210	5-92	SCRUB HEAD DOWN FORCE	
ENGINE WILL NOT CRANK (all engines)		(SV-8) (8210)-continued	5-120
(8200/8210)	5-93	SCRUB HEAD EDGE SCRUB WILL	
ENGINE WILL NOT RUN (lpg) (8200/8210)	5-94	NOT SHIFT (8210)	5-121
ENGINE WILL NOT RUN (gas) (8200/8210)	5-95	SQUEEGEE WILL NOT LOWER	
ENGINE WILL NOT RUN (diesel)		(8210)	5-122
(8200/8210)	5-96	SCRUB VACUUM FAN WILL NOT	
NO SPEED CHANGE FROM ENGINE		RUN (8210)	5-123
GOVERNOR (8200/8210)	5-97	SOLUTION CONTROL WILL NOT	
		OPERATE (8210)	5-124
		DETERGENT PUMP WILL NOT	
		OPERATE (8210)	5-125
		ES™ WILL NOT OPERATE (8210)	5-126

---

**INTRODUCTION**

---

The 8200/8210 electrical system consists of the battery, instrument panel, touch panel, switches, relays, and circuit breakers. This section includes information on these components and their troubleshooting.

## BATTERY

---

The battery used in the machine is a low maintenance battery. It has been constructed with special materials and has extra electrolyte to reduce or eliminate maintenance. Its design reduces electrolyte loss and contamination. Do not add water, remove the battery vent plugs, or check the battery specific gravity. For specific instructions, see the battery label.

Do not allow the battery to remain in discharged condition for any time. Do not operate the machine if the battery is in poor condition or discharged beyond 80%, specific gravity below 1.120.

After the first 50 hours of operation, and every 800 hours after that, clean and tighten the battery connections.

Periodically clean the top surface of the batteries and the terminals, and check for loose connections. Use a strong solution of baking soda and water. Brush the solution sparingly over the battery tops, terminals, and cable clamps. Do not allow any baking soda solution to enter the batteries. Use a wire brush to clean the terminal posts and the cable connectors. After cleaning, apply a coating of clear battery post protectant to the terminals and the cable connectors. Keep the tops of the batteries clean and dry.

Keep all metallic objects off the top of the batteries, which may cause a short circuit. Replace any worn or damaged wires.

The electrolyte level in regular non-sealed batteries can be checked. The level must always be above the battery plates. Never add acid to the batteries, only distilled water. Keep the battery caps on the batteries always except when adding water or taking hydrometer readings.

**FOR SAFETY: When Servicing Machine,  
Avoid Contact With Battery Acid.**





Using a hydrometer to measure the specific gravity is a way to determine the charge level and condition of the batteries. If one or more of the battery cells test lower than the other battery cells (0.050 or more), the cell is damaged, shorted, or is about to fail.

*NOTE: Do not take readings immediately after adding distilled water. If the water and acid are not thoroughly mixed, the readings may not be accurate. Check the hydrometer readings against the following chart to determine the remaining battery charge level:*

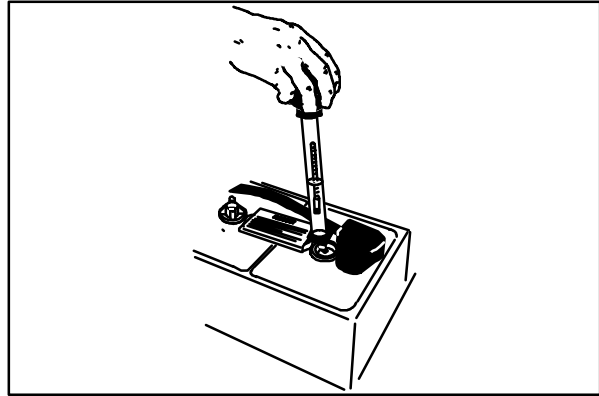

SPECIFIC GRAVITY at 27° C (80° F)	BATTERY CHARGE
1.290	100% Charged
1.252	75% Charged
1.200	50% Charged
1.177	25% Charged
1.140	Discharged

*NOTE: If the readings are taken when the battery electrolyte is any temperature other than 27° C (80° F), the reading must be temperature corrected. Add or subtract to the specific gravity reading 0.004, 4 points, for each 6° C (10° F) above or below 27° C (80° F).*

## ELECTRICAL

### TO REPLACE BATTERY

**FOR SAFETY: Before Leaving Or Servicing Machine; Stop On Level Surface, Set Parking Brake, Turn Off Machine And Remove Key.**

1. Open the engine cover and side door.

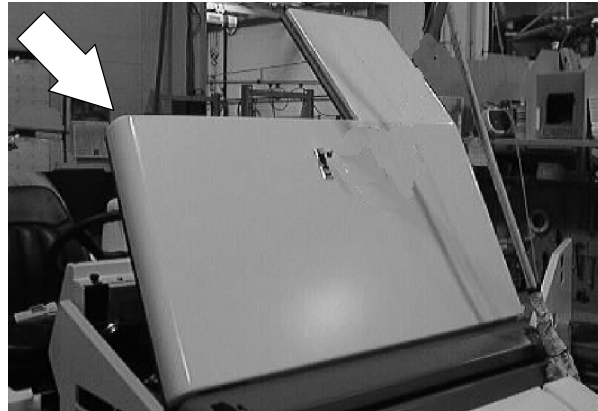

2. Disconnect the battery cables.

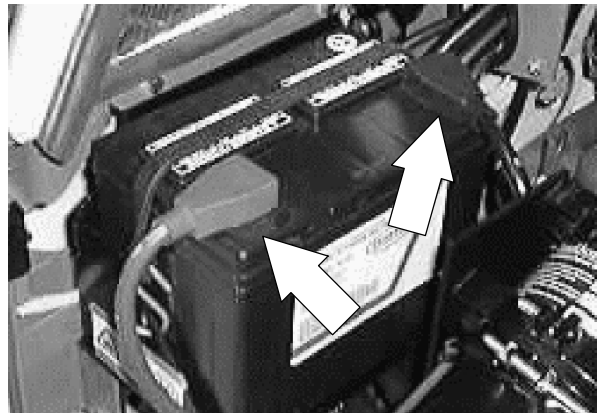

3. Remove the battery hold down strap.



4. Lift the battery out of the machine using a battery lifting device.

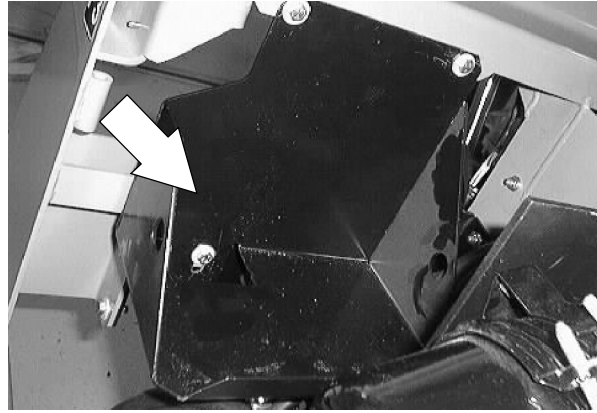

5. Make sure that both posts are clean on the new battery. Position the new battery in the machine.



6. Reinstall the battery hold down strap.

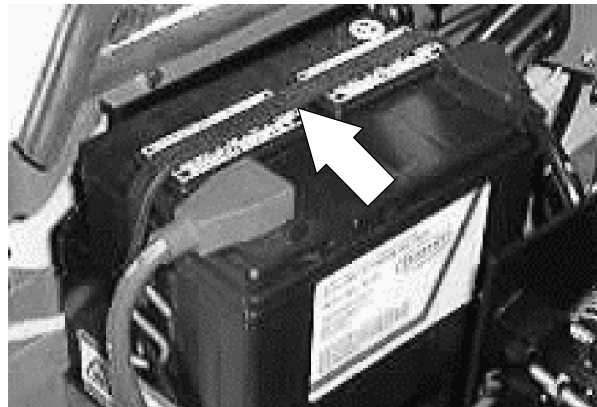

7. Reconnect the positive, then the negative battery cables.

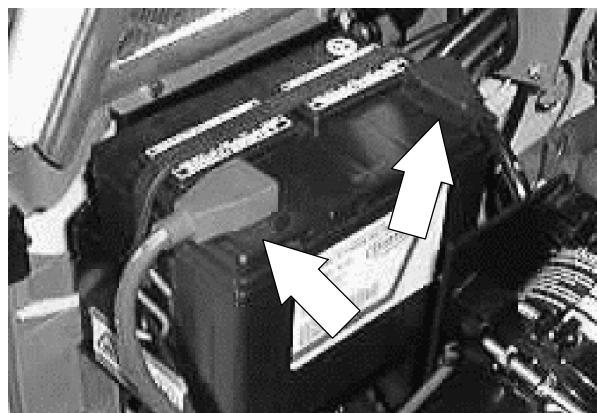

8. Close the engine cover and side door.

## INSTRUMENT PANEL

The instrument panel consists of a key switch, light switch, hour meter, fuel gauge, horn button, and indicator light panel.

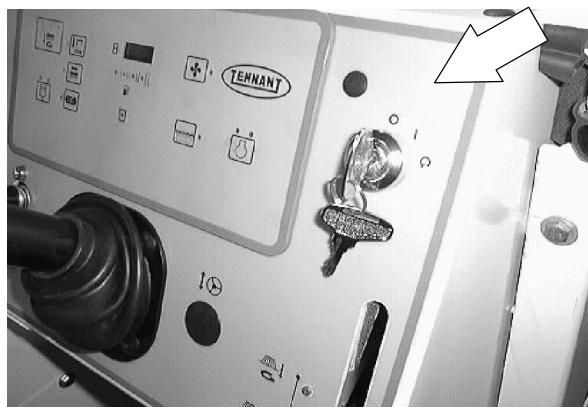

## TO REPLACE INDICATOR LIGHT

**FOR SAFETY: Before Leaving Or Servicing Machine; Stop On Level Surface, Set Parking Brake, Turn Off Machine And Remove Key.**

1. Open the engine cover and side door.



2. Disconnect the battery cables.

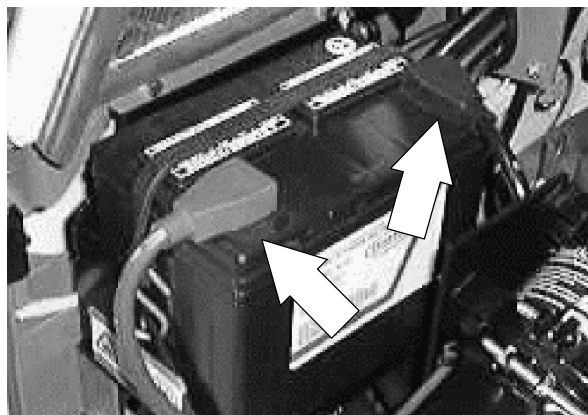

3. Locate the indicator light panel mount plate next to the power steering hoses.

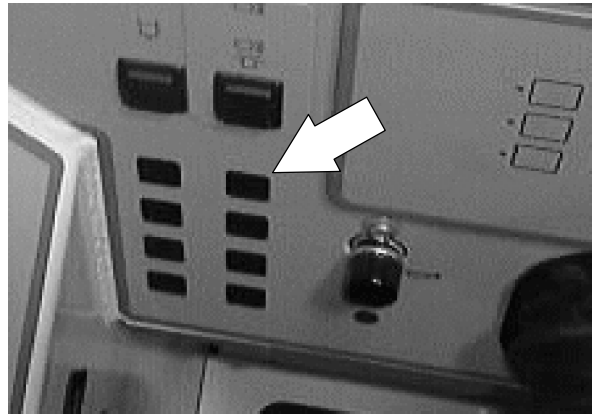

4. Remove the two nyloc nuts holding the mount plate to the instrument panel. Pull the mount plate back away from the instrument panel.

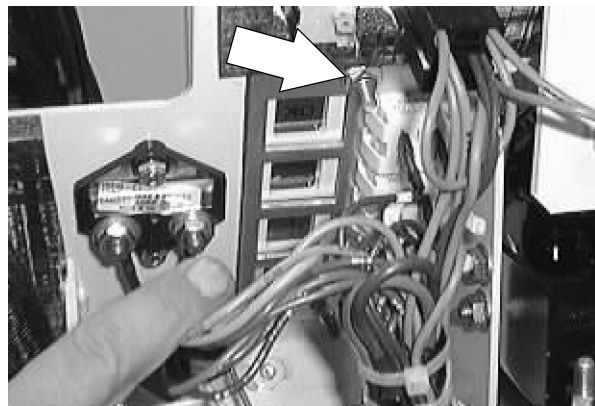

5. Unplug the two wires leading to the light that needs to be changed.

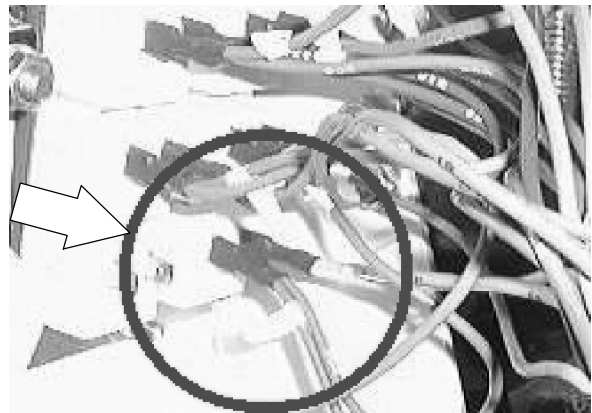

6. Squeeze the sides of the light and push the light out of the mount plate.

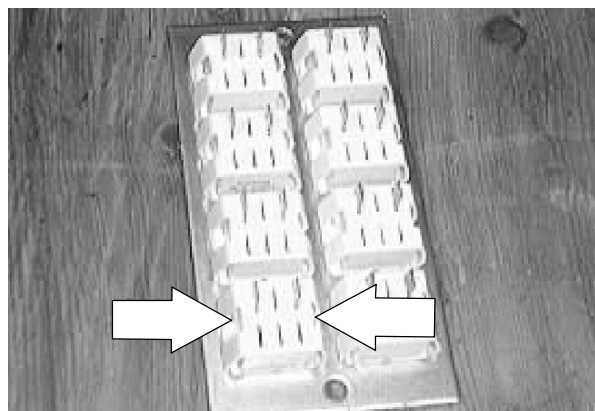

## ELECTRICAL

7. Install the new light in the mount plate. Snap in place.

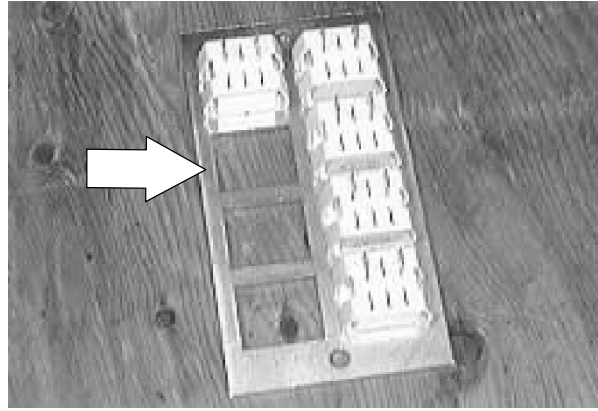

8. Reconnect the wires to the new light. See schematic in this section.

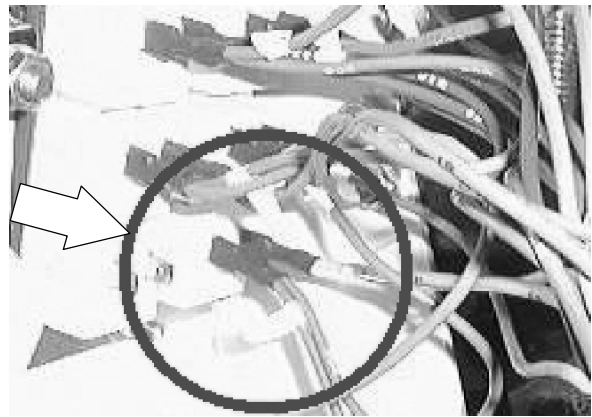

9. Position the mount plate back on the instrument panel. Reinstall the two nyloc nuts and tighten.



10. Reconnect the battery cables.

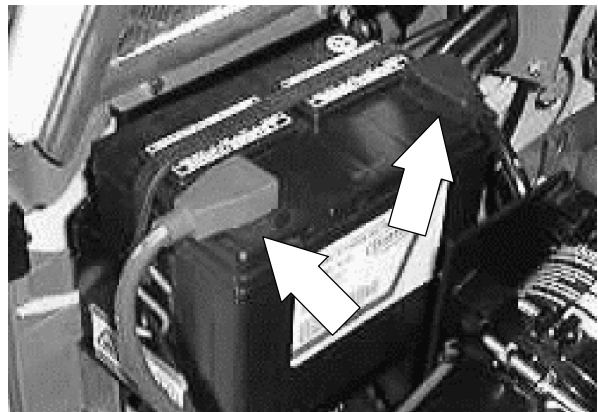

11. Close the engine cover and side door. Operate the machine and check the indicator lights for proper operation.

**TO REPLACE TOUCH PANEL**

**FOR SAFETY: Before Leaving Or Servicing Machine; Stop On Level Surface, Set Parking Brake.**

1. Open the engine cover and side door.



2. Disconnect the battery cables.

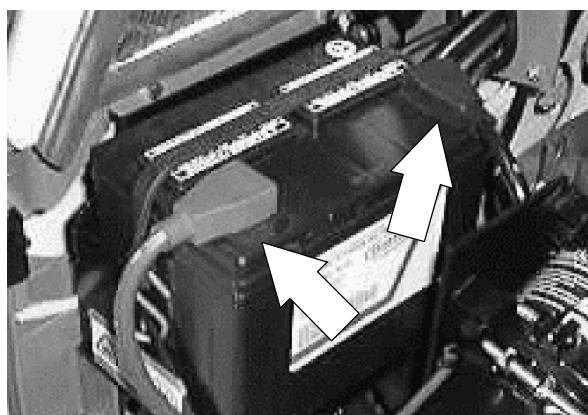

3. Locate the two hex screws holding the engine governor box mount bracket to the front of the dash panel. Remove the two screws.

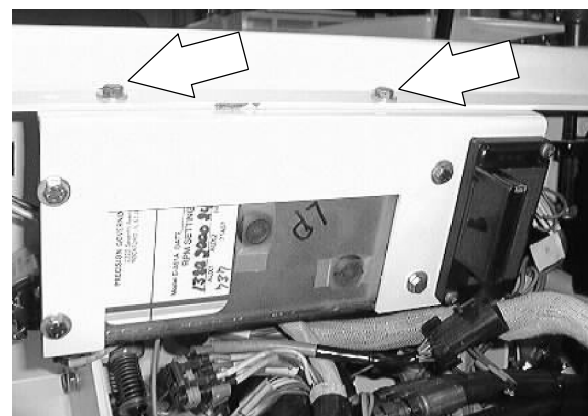

## ELECTRICAL

4. Position the governor and bracket out of the way to allow access to the back side of the touch panel.
5. Un-plug the touch panel from the main electrical harness.

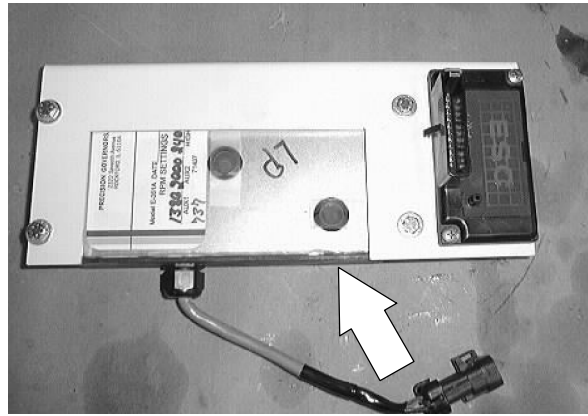

6. Remove the four hex screws holding the two angle brackets to the back of the touch panel. Remove the angle brackets.

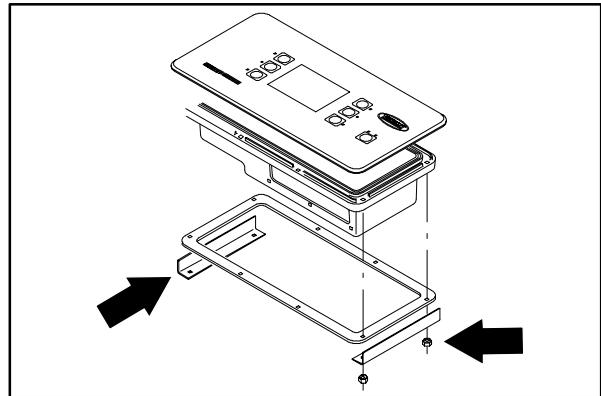

7. Pull the touch panel out of the mounting hole in the dash panel.

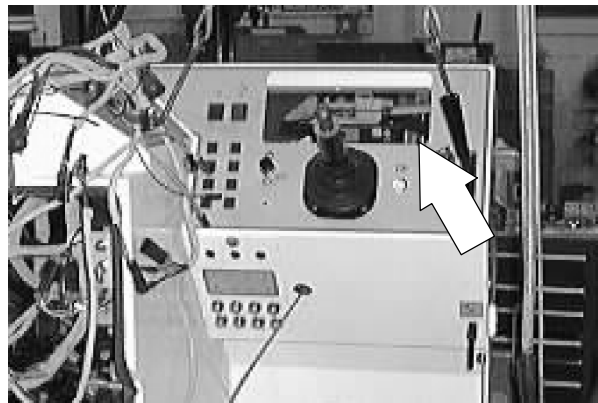

8. Position the new touch panel into the mounting hole in the dash panel.





9. Install the two touch panel mounting angle brackets.
10. Install the four hex screws holding the two angle brackets to the back of the touch panel. Tighten these hex screws lightly.
11. Plug the touch panel into the main electrical harness.

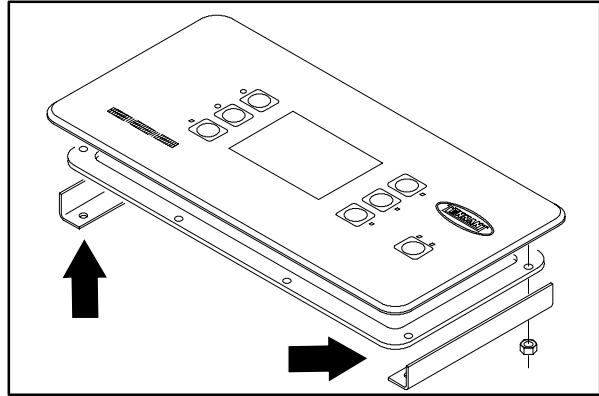

12. Position the governor and bracket back in place at the front of the dash panel.
13. Reinstall the two screws into the governor mount bracket and tighten to 7.6 - 9.9 Nm (5.6 - 7.3 ft lb).

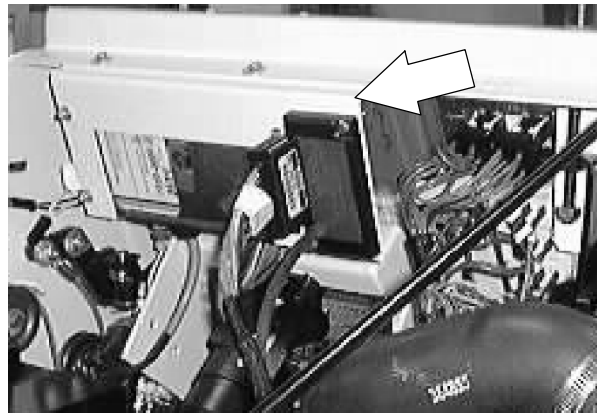

14. Reconnect the battery cables.

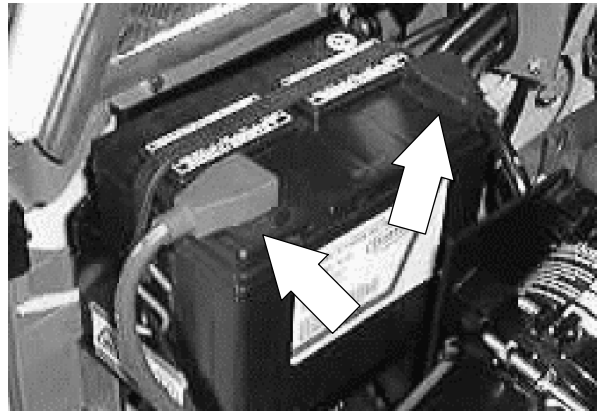

15. Close the engine cover and side door.



16. Start the machine and check the touch panel for proper operation.

## ELECTRICAL

### TO REPLACE ELECTRICAL RELAY

**FOR SAFETY: Before Leaving Or Servicing Machine; Stop On Level Surface, Set Parking Brake, Turn Off Machine And Remove Key.**

1. Open the engine cover and side door.

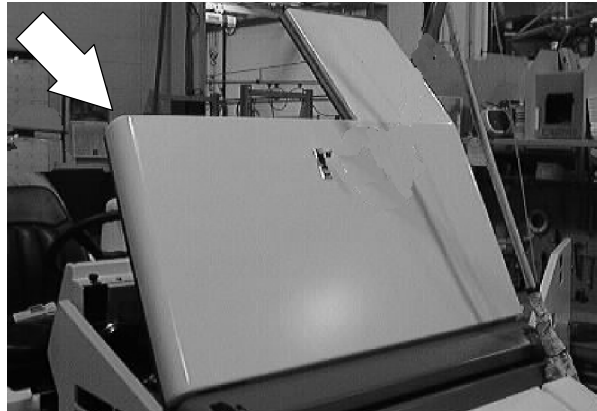

2. Disconnect the battery cables.

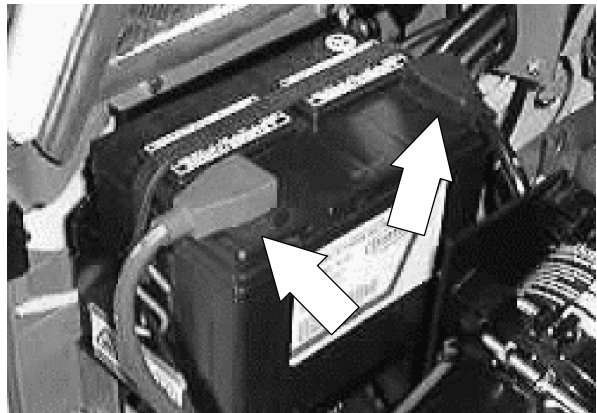

3. Locate the circuit breaker/relay mount plate below the indicator lights on the dash panel.

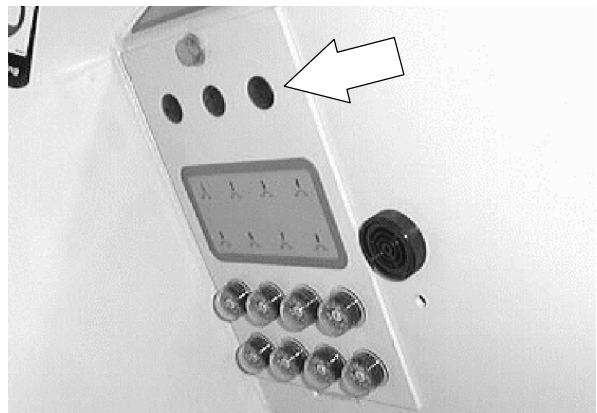

4. Remove the hex screw holding the circuit breaker/relay mount plate to the dash panel.

*NOTE: Pull the mount plate back for access to the relays.*



5. Use the electrical schematic to locate the relay that needs to be replaced.



6. Push the two tabs on the electrical plug of the main harness and remove it from the faulty relay.

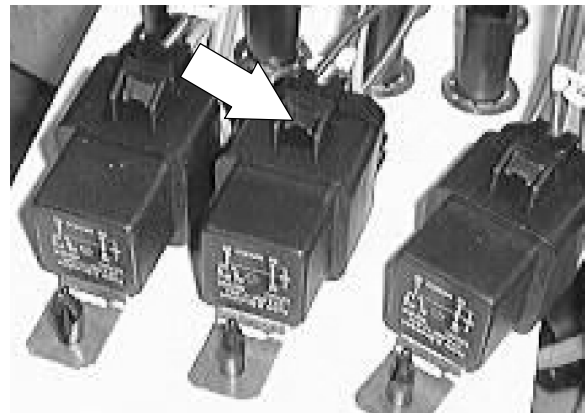

7. Remove the plastic rivet holding the relay to the panel. Remove and discard the relay.

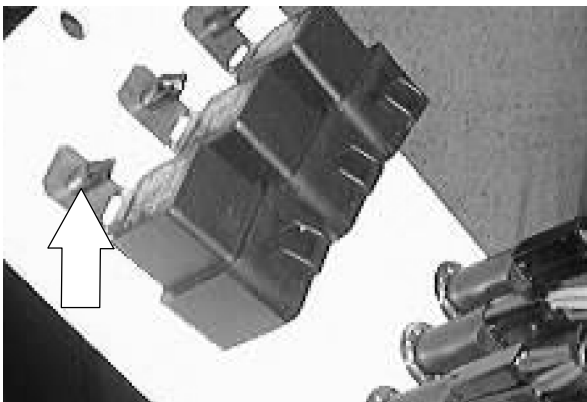

## ELECTRICAL

- Position the new relay on the mount panel. Reinstall the plastic rivet.

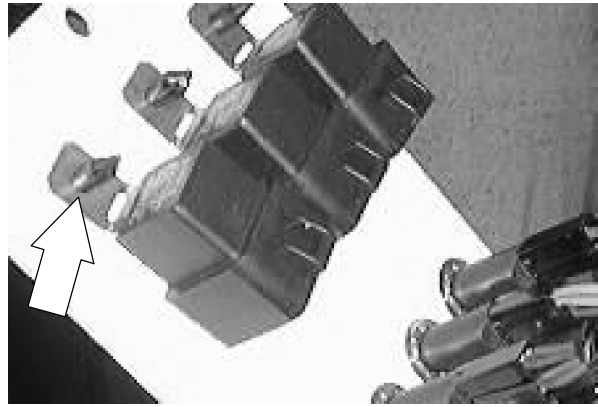

- Plug the main harness in the new relay. See the schematic in this section.

*NOTE: The harness plug will only fit in the new relay in one direction.*



- Position the mount panel back on the dash panel. Reinstall the hex screw and tighten.



- Reconnect the battery cables.

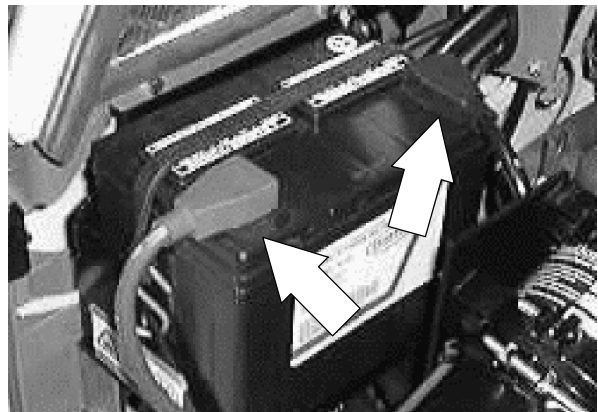

- Start the engine and close the engine cover and side door. Check the new relay for proper operation.

**CIRCUIT BREAKERS**

The circuit breakers are resettable electrical circuit protection devices. Their design stops the flow of current in the event of a circuit overload. Once a circuit breaker is tripped, it must be reset manually. Press the reset button after the breaker has cooled down.

If the overload that caused the circuit breaker to trip is still there, the circuit breaker will continue to stop current flow until the problem is corrected.

The circuit breakers are located in the operator compartment.

This chart lists the circuit breakers and the electrical components they protect.

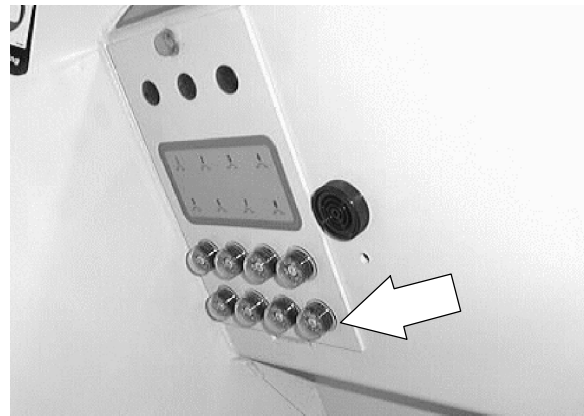

<b>Circuit Breaker</b>	<b>Rating</b>	<b>Circuit Protected</b>
CB-1	15 A	Horn
CB-2	15 A	Ignition
CB-3	15 A	Headlights / Taillights
CB-4	5 A	Logic Power
CB-5	15 A	Sweeping
CB-6	15 A	Scrubbing
CB-7	15 A	Scrubbing
CB-8	15 A	Filter Shaker Motor

**FUSE (DIESEL ONLY)**

The fuse is a one-time protection device designed to stop the flow of current in the event of a circuit overload. Never substitute higher value fuses than specified.

The fuse is located in the operator compartment. Remove the circuit breaker panel to gain access to the fuse.

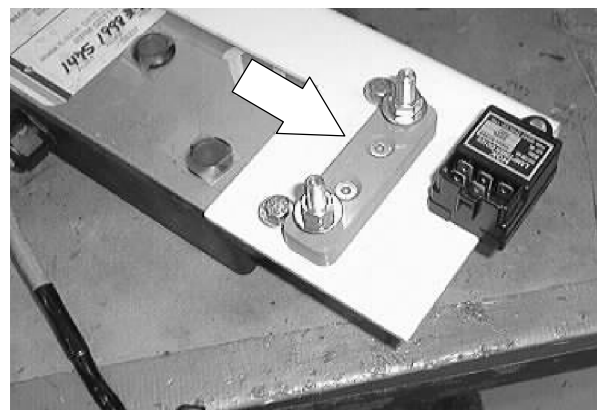

<b>Fuse</b>	<b>Rating</b>	<b>Circuit Protected</b>
FU-1	40 A	Glow plugs

## TO REPLACE CIRCUIT BREAKER

**FOR SAFETY: Before Leaving Or Servicing Machine; Stop On Level Surface, Set Parking Brake, Turn Off Machine And Remove Key.**

1. Open the engine cover and side door.

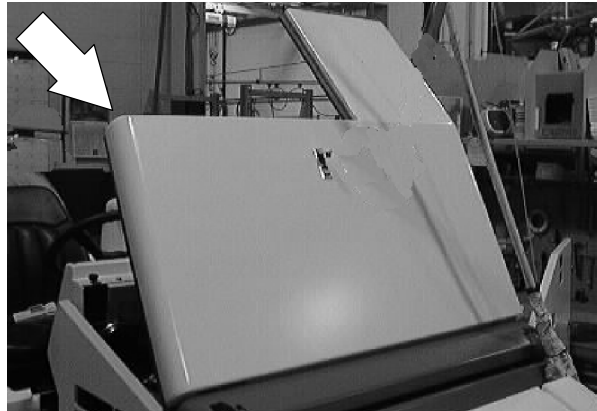

2. Disconnect the battery cables.

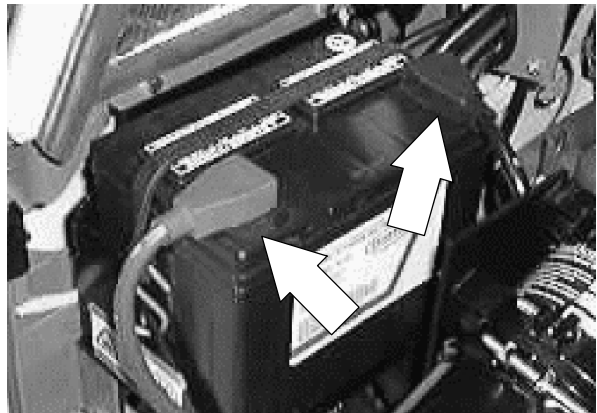

3. Locate the circuit breaker/relay mount plate below the indicator lights on the dash panel.



4. Remove the hex screw holding the circuit breaker/relay mount plate to the dash panel.

*NOTE: Pull the mount plate back for access to the circuit breakers.*



5. Use the electrical schematic to locate the circuit breaker that needs to be replaced.

6. Disconnect the wires leading to the faulty circuit breaker.



7. The metal ring must be removed in order to remove the old circuit breaker. It may need to be cut off.

8. Remove the old circuit breaker and discard.

9. Position the new circuit breaker in the hole in the panel. Install the metal lock ring.

*NOTE: The circuit breaker will only fit in the hole in one direction.*

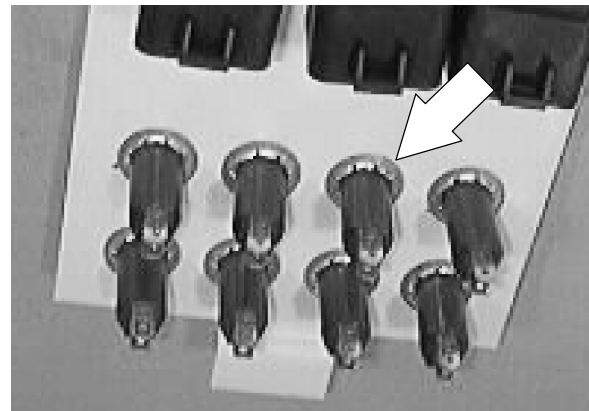

10. Plug the main harness wires into the new circuit breaker. See the schematic in this section.



## ELECTRICAL

11. Position the mount panel back on the dash panel. Reinstall the hex screw and tighten.



12. Reconnect the battery cables.

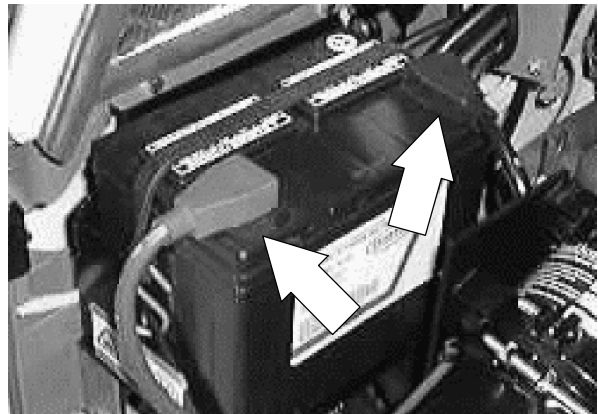

13. Start the engine and close the engine cover and side door. Check the new circuit breaker for proper operation.





**TO REPLACE GLOW PLUG FUSE**

**FOR SAFETY: Before Leaving Or Servicing Machine; Stop On Level Surface, Set Parking Brake, Turn Off Machine And Remove Key.**

1. Open the engine cover and side door.



2. Disconnect the battery cables.

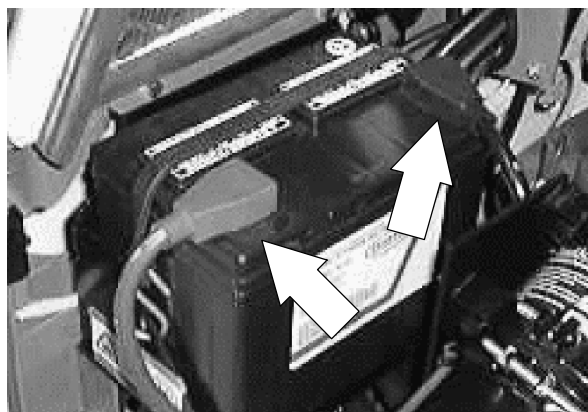

3. Locate the glow plug fuse on the governor control box mount plate.

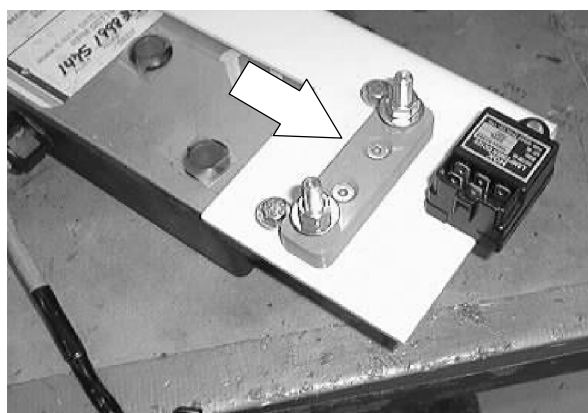

## ELECTRICAL

4. Loosen the two hex nuts holding the wires and fuse into the fuse holder.

*NOTE: Do not remove the hex nuts.*

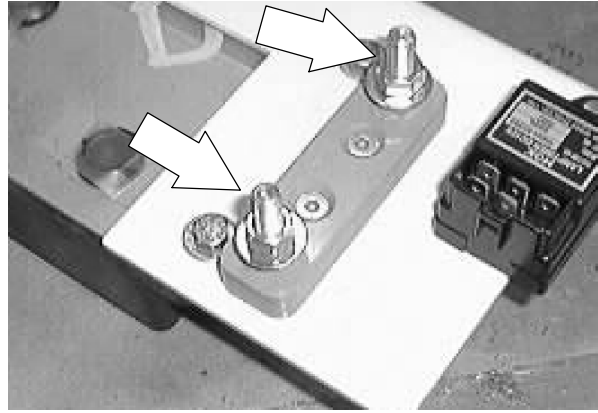

5. Slip the glow plug fuse out of the holder.
6. Position the new glow plug fuse into the holder, under the glow plug wires.

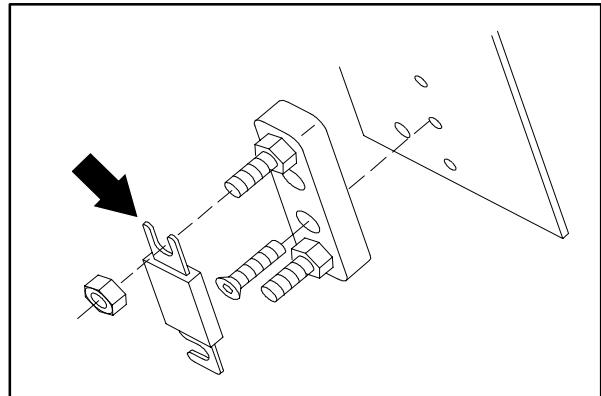

7. Hand tighten the two hex nuts. Do not over tighten.

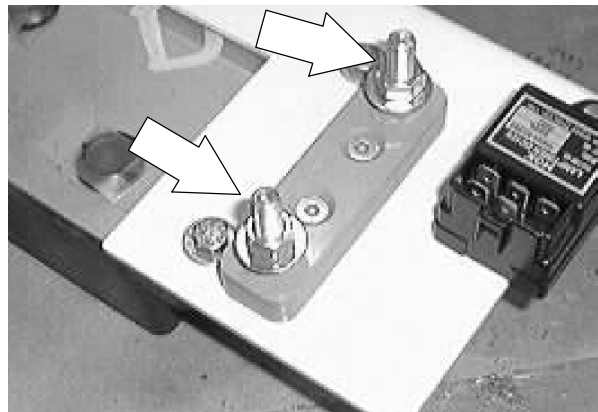

8. Reconnect the battery cables and close the engine cover.



9. Check the glow plug cycle for proper operation.

**TO REPLACE GLOW PLUG TIMER**

**FOR SAFETY: Before Leaving Or Servicing Machine; Stop On Level Surface, Set Parking Brake, Turn Off Machine And Remove Key.**

1. Open the engine cover and side door.

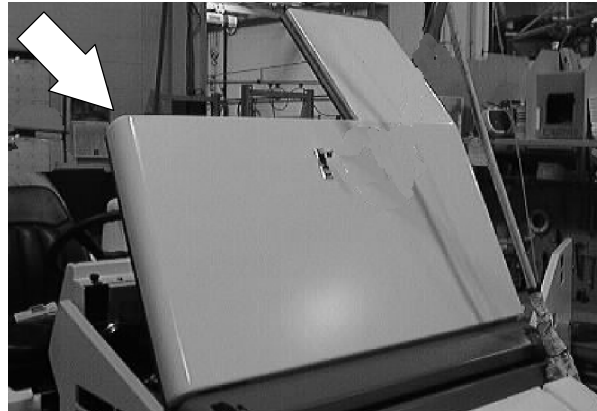

2. Disconnect the battery cables.

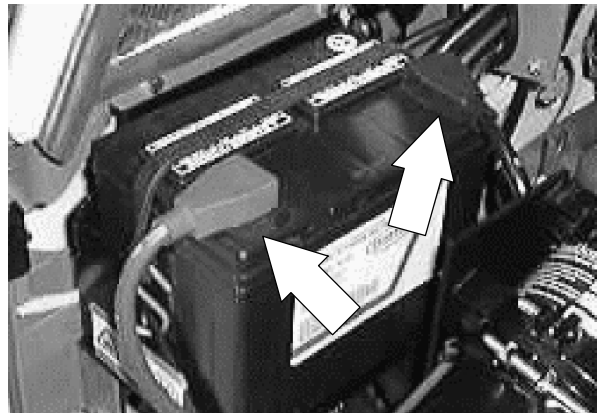

3. Locate the glow plug timer on the governor control box mount plate.

4. Disconnect the wires leading to the glow plug timer.

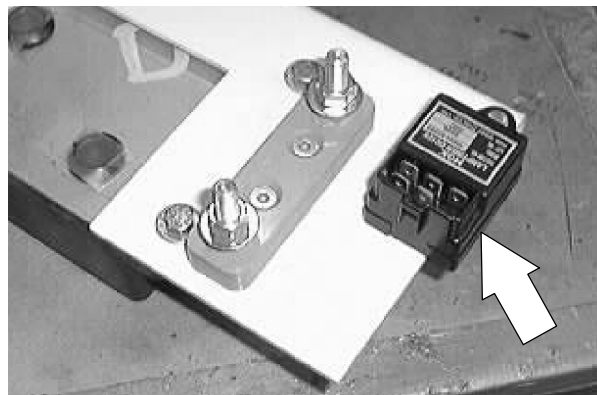

## ELECTRICAL

5. Remove the hex screw holding the glow plug timer to the mount plate.
6. Remove the glow plug timer.
7. Position the new glow plug timer onto the mount plate. Reinstall the hex screw and hand tighten.
8. Reconnect the wires to the glow plug timer. See the schematic in this section.
9. Reconnect the battery cables.

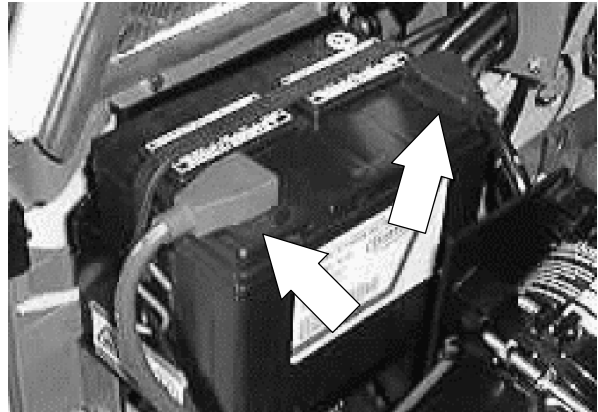

10. Close the engine cover and side door.



11. Check the glow plug cycle for proper operation.

**TO REPLACE FILTER SHAKER MOTOR**

**FOR SAFETY: Before Leaving Or Servicing Machine; Stop On Level Surface, Set Parking Brake, Turn Off Machine And Remove Key.**

1. Un-latch the two rubber hopper cover locks.

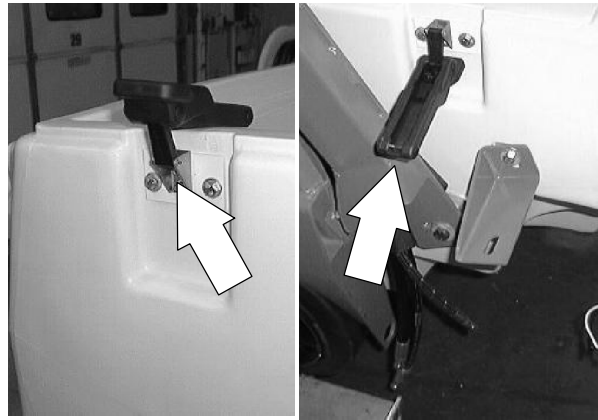

2. Open the hopper cover.



3. Locate the filter shaker motor on the top side of the filter shaker assembly, located in the hopper cover.

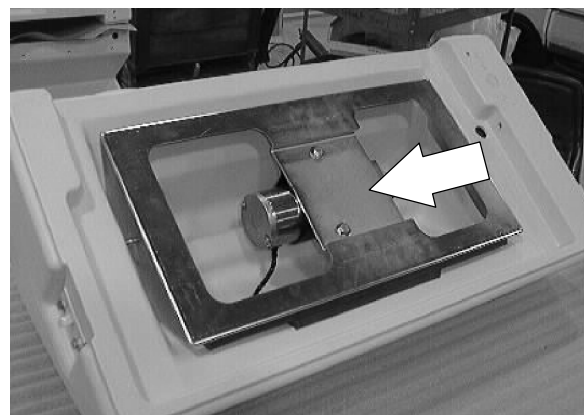

## ELECTRICAL

4. Unplug the filter shaker motor from the hopper harness.

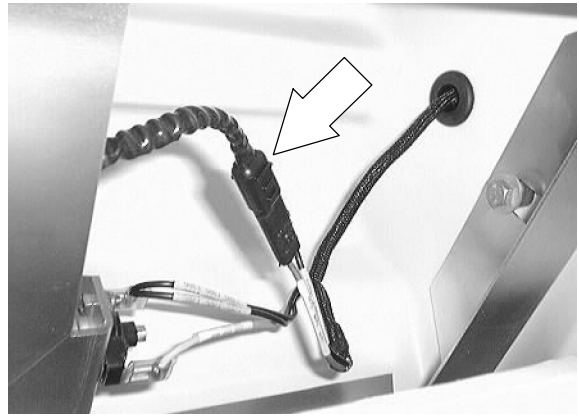

5. Remove the two hex screws holding the shaker motor bracket to the motor assembly. Remove the motor from the assembly.

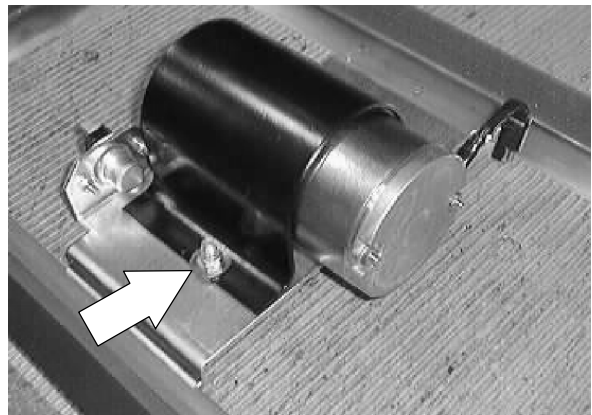

6. Loosen the two set screws on the eccentric weight. Pull the weight off the motor shaft.

7. Install the eccentric weight on the new shaker motor. Position the weight flush with the guard plate.

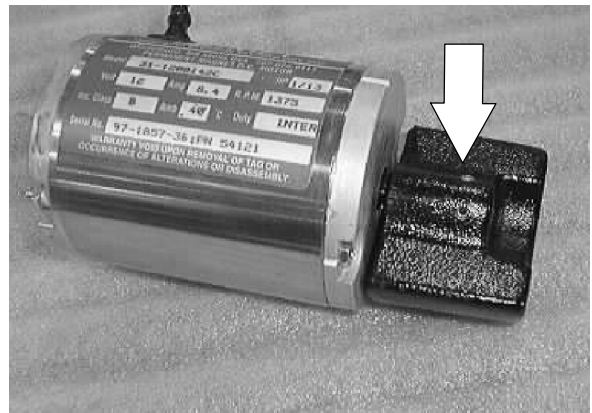

8. Install the new shaker motor on the assembly mount plate. Tighten the two hex screws to 18 - 24 Nm (15 - 20 ft lb).

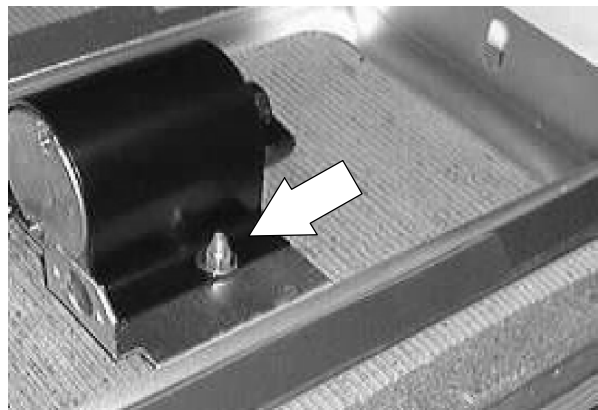

9. Plug the shaker motor into the hopper harness.



10. Close the hopper cover and latch the two rubber locks.



11. Start the machine. Test the shaker motor for proper operation.

### THERMO SENTRY™

The Thermo Sentry™ senses the temperature of the air pulled up from the hopper. If there is a fire in the hopper, the Thermo Sentry™ stops the vacuum fan and cuts off the air flow.

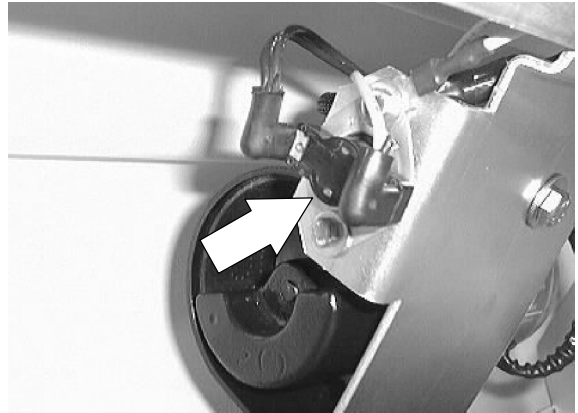

### TO REPLACE THERMO SENTRY™

**FOR SAFETY: Before Leaving Or Servicing Machine; Stop On Level Surface, Set Parking Brake, Turn Off Machine And Remove Key.**

1. Open the hopper cover.



2. Locate the Thermo Sentry™ on the side of the filter shaker motor bracket. Unplug the two wires leading to the Thermo Sentry™.

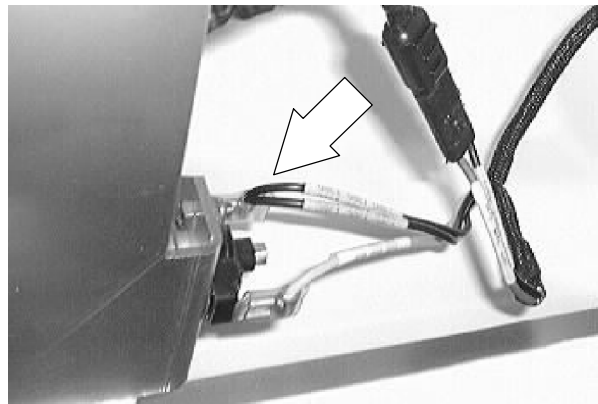



3. Remove the hex screws holding the Thermo Sentry™ to the bracket. Remove from the hopper cover.
4. Install the new Thermo Sentry™ on the bracket. Reinstall the hardware and tighten,

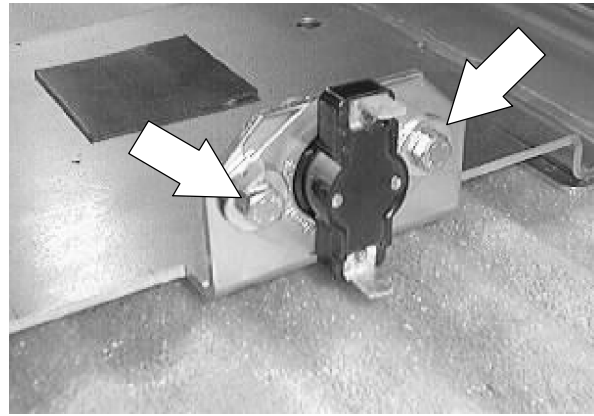

5. Reconnect the wires to the new Thermo Sentry™

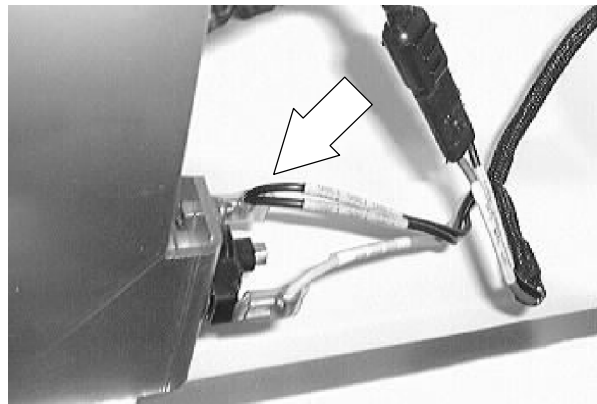

6. Close the hopper cover.



### TO REPLACE ES™ PUMP

1. Start the machine and lower the scrub head. Shut off the machine.

**FOR SAFETY: Before Leaving Or Servicing Machine; Stop On Level Surface, Set Parking Brake.**

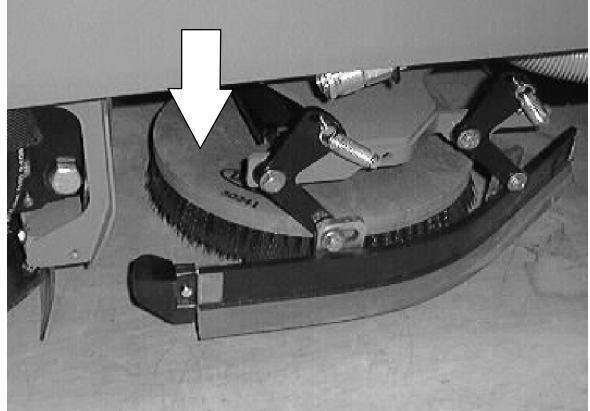

2. Locate the ES™ pump on the left hand side of the machine, under the machine frame, behind the left side main brush door.

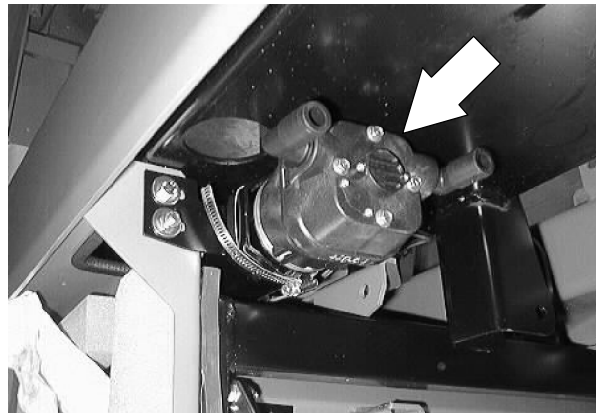

3. Disconnect the ES™ pump from the main electrical harness.

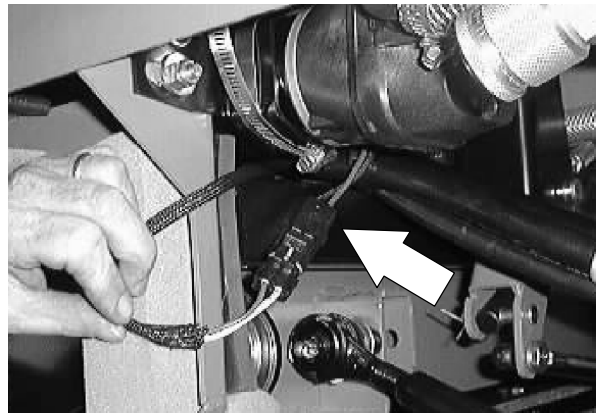

4. Loosen the worm drive clamps holding the two solution hoses leading to the ES™ pump. Remove the hoses from the pump.

*NOTE: Make sure to note which hose goes to what fitting.*



5. Remove the two hex screws holding the ES™ pump and mount bracket to the machine frame. Remove the pump from the machine.

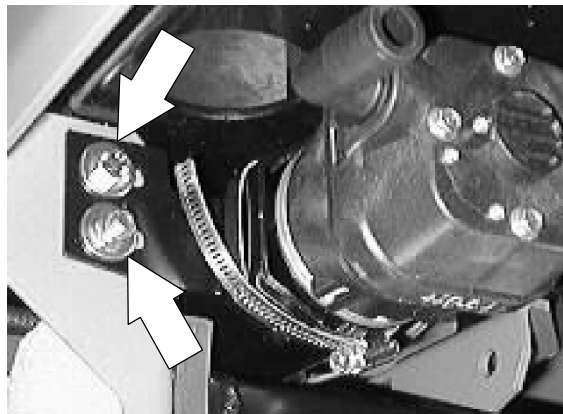

6. Remove the worm drive clamp holding the mount bracket to the ES™ pump.

*NOTE: Remove and retain the mount bracket.*

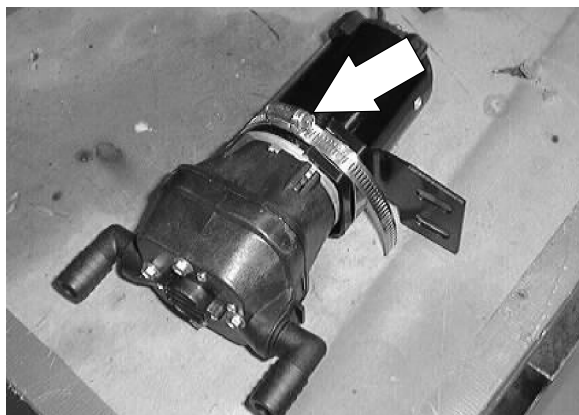

*NOTE: Make sure the new pump has the correct fittings in the same orientation.*

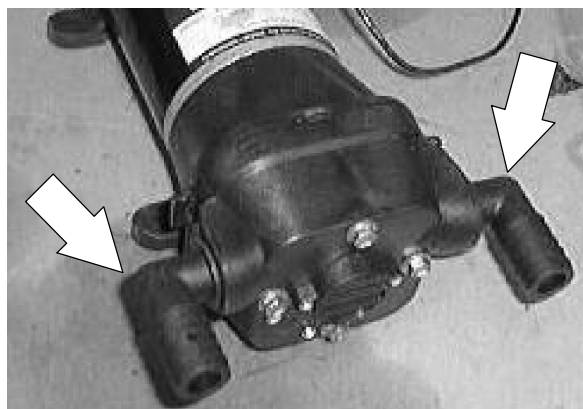

7. Install the mount bracket on the new ES™ pump in the same orientation as it was removed. Tighten the worm drive clamp.

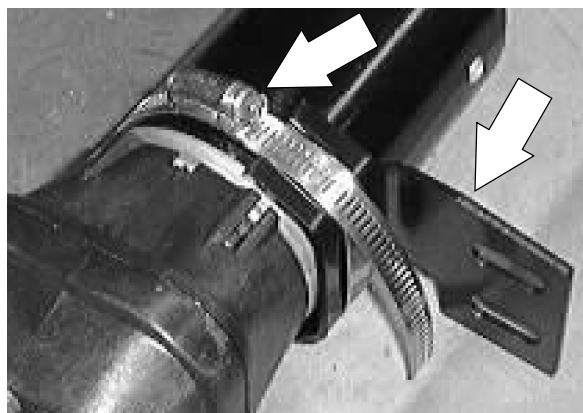

8. Install the new pump and mount bracket assembly in the machine. Reinstall the two hex screws and tighten to 18 - 24 Nm (15 - 20 ft lb).

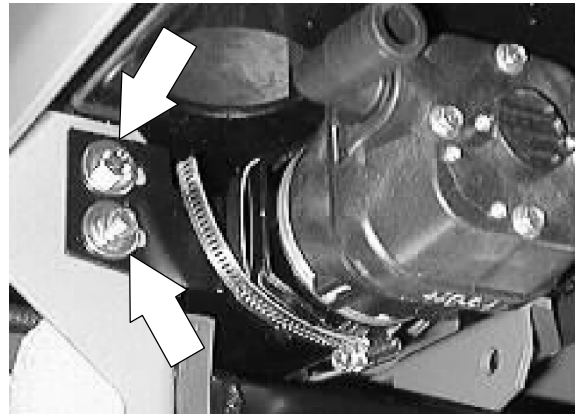

9. Reconnect the two solution hoses to the new ES™ pump. Tighten the worm drive clamps.

*NOTE: Make sure the hoses are installed on the correct fitting.*



10. Connect the new ES™ pump to the main harness.



11. Start the machine and operate the ES™ pump. Check for proper operation.

**TO REPLACE DETERGENT PUMP**

1. Start the machine and lower the scrub head. Shut off the machine.

**FOR SAFETY: Before Leaving Or Servicing Machine; Stop On Level Surface, Set Parking Brake.**

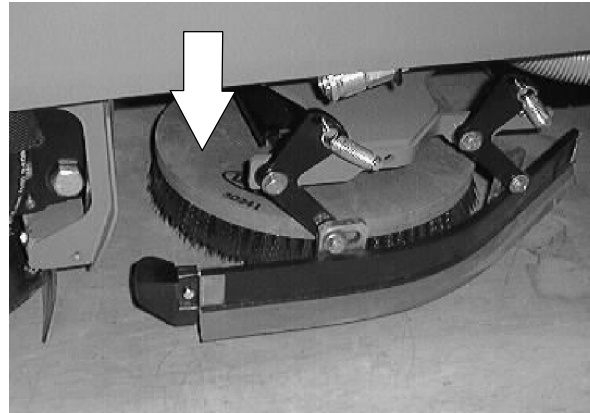

2. Locate the detergent pump on the right hand side of the machine, under the operator compartment, behind the right side main brush door.

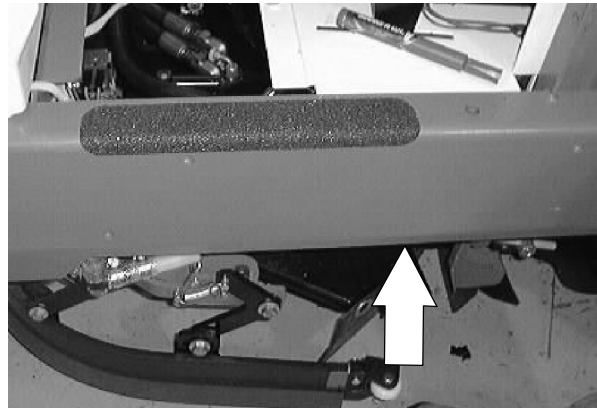

3. Disconnect the detergent pump from the main electrical harness.

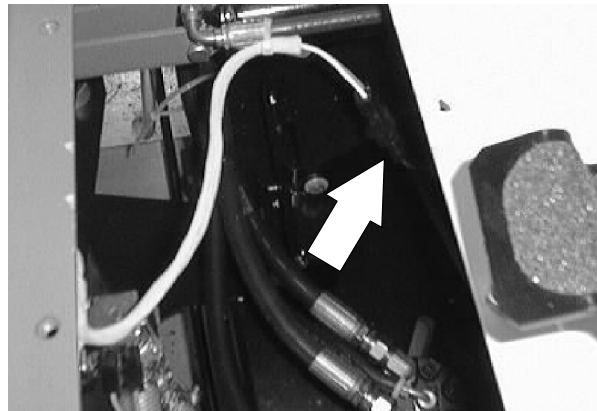

4. Loosen the worm drive clamps holding the two hoses leading to the detergent pump. Remove the hoses from the pump.

*NOTE: Make sure to note which hose goes to what port.*

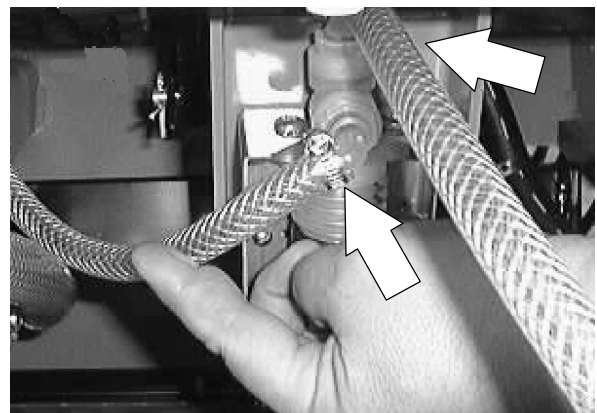

## ELECTRICAL

5. Remove the two hex screws holding the detergent pump assembly to the mount bracket. Remove the pump assembly from the machine.

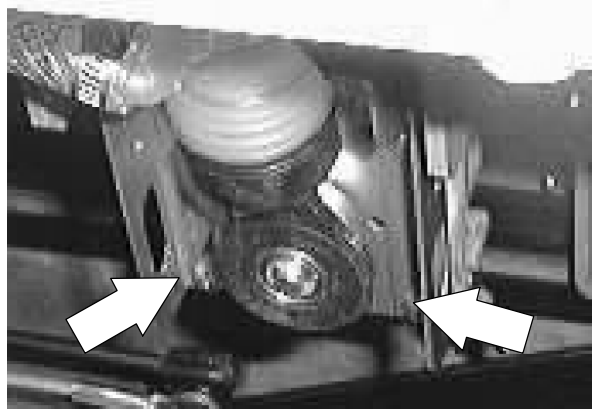

6. Install the new pump assembly on the mount bracket. Reinstall the two hex screws and nuts. Hand tighten.

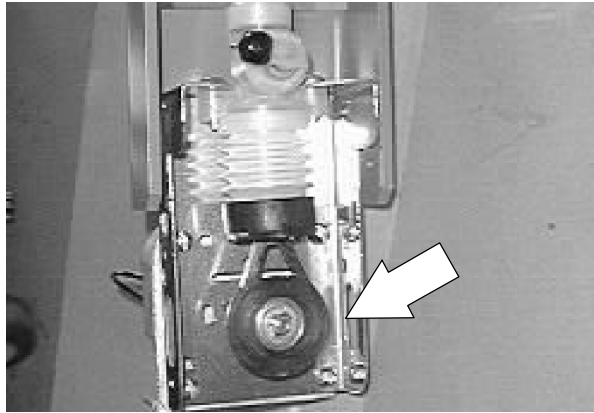

7. Reconnect the two hoses to the new detergent pump. Tighten the worm drive clamps.

*NOTE: Make sure the hoses are installed on the correct ports.*

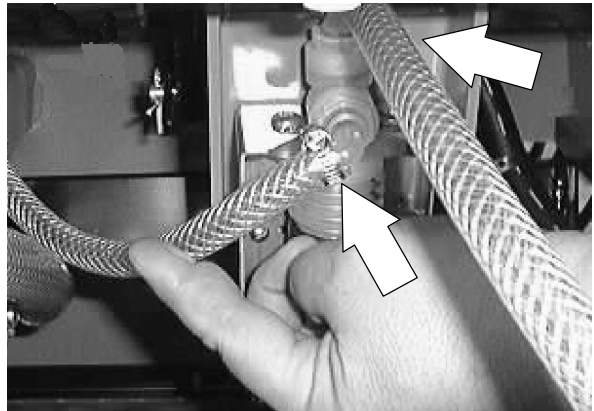

8. Connect the new detergent pump to the main harness.

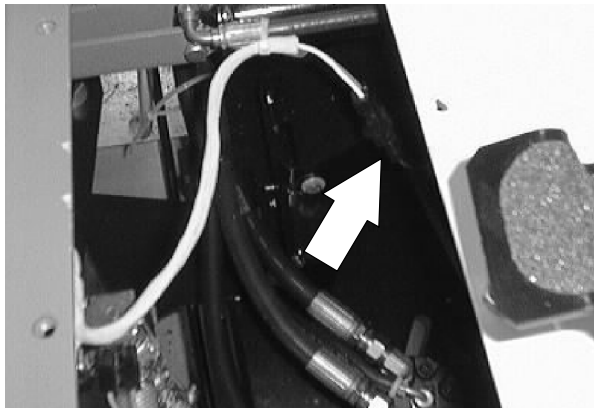

9. Start the machine and operate the detergent pump. Check for proper operation.







ELECTRICAL SCHEMATIC

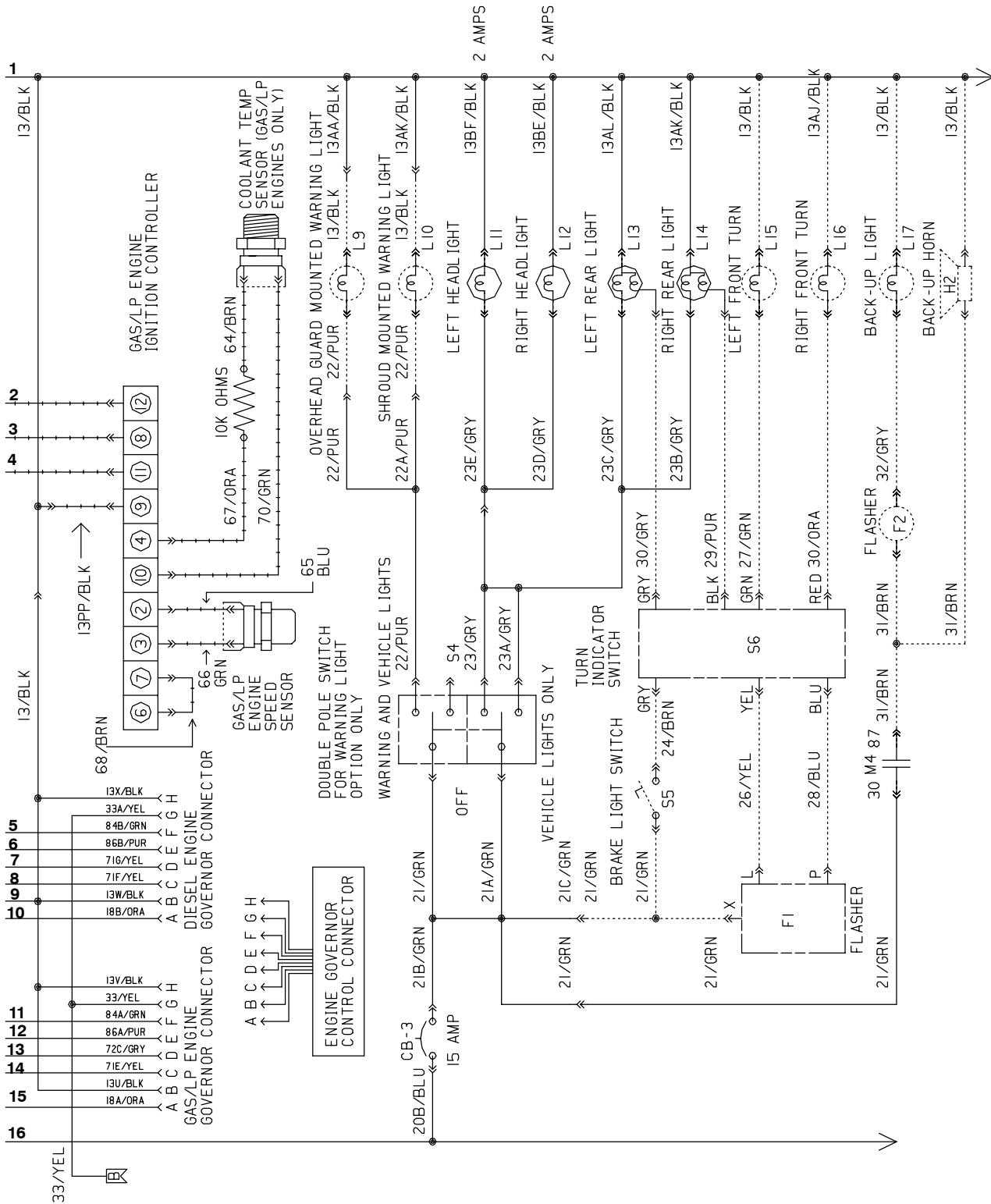

351556 - ALL

## ELECTRICAL SCHEMATIC

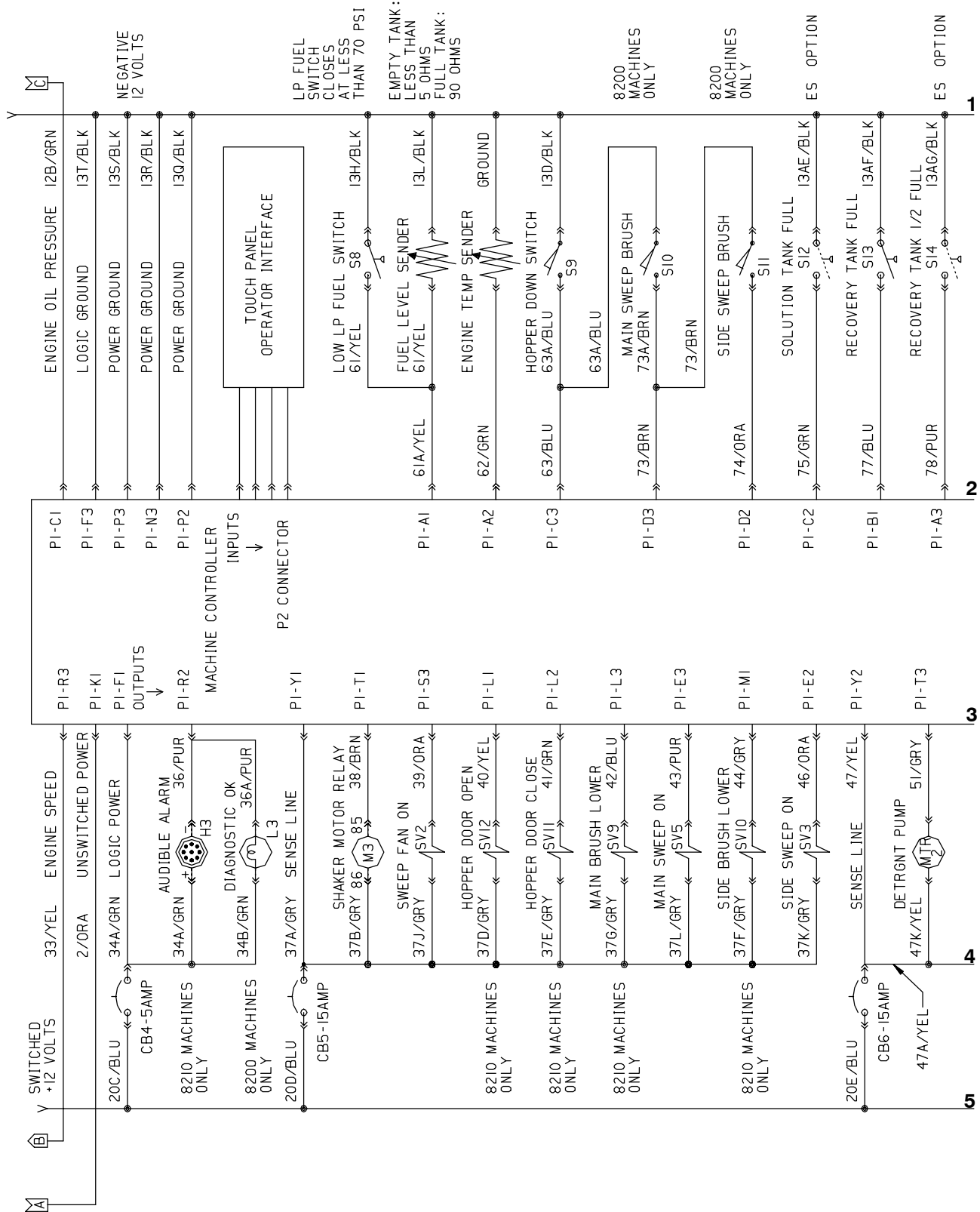

351556 - ALL

ELECTRICAL SCHEMATIC

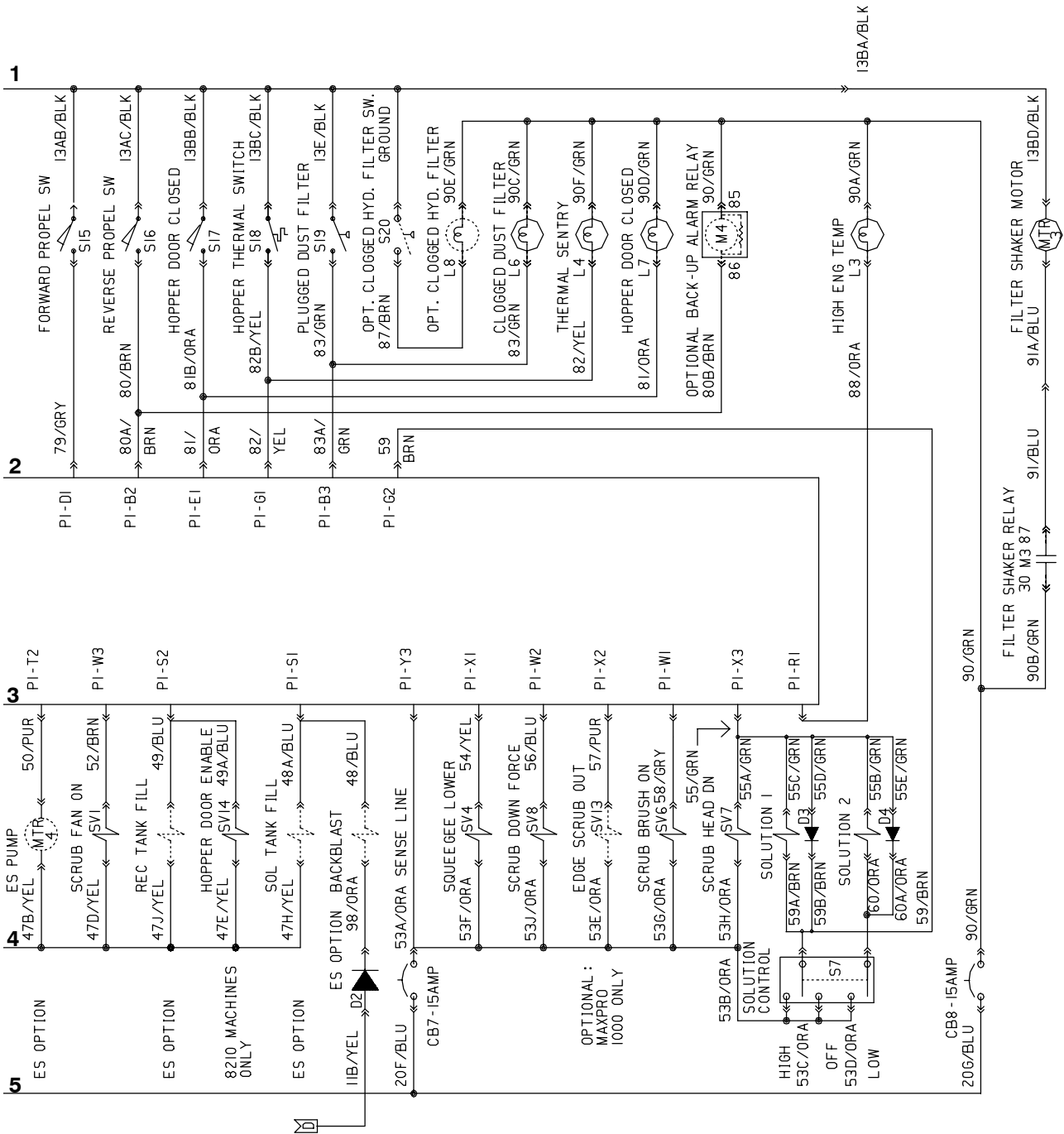

351556 - ALL

HOPPER WIRE HARNESS DIAGRAM

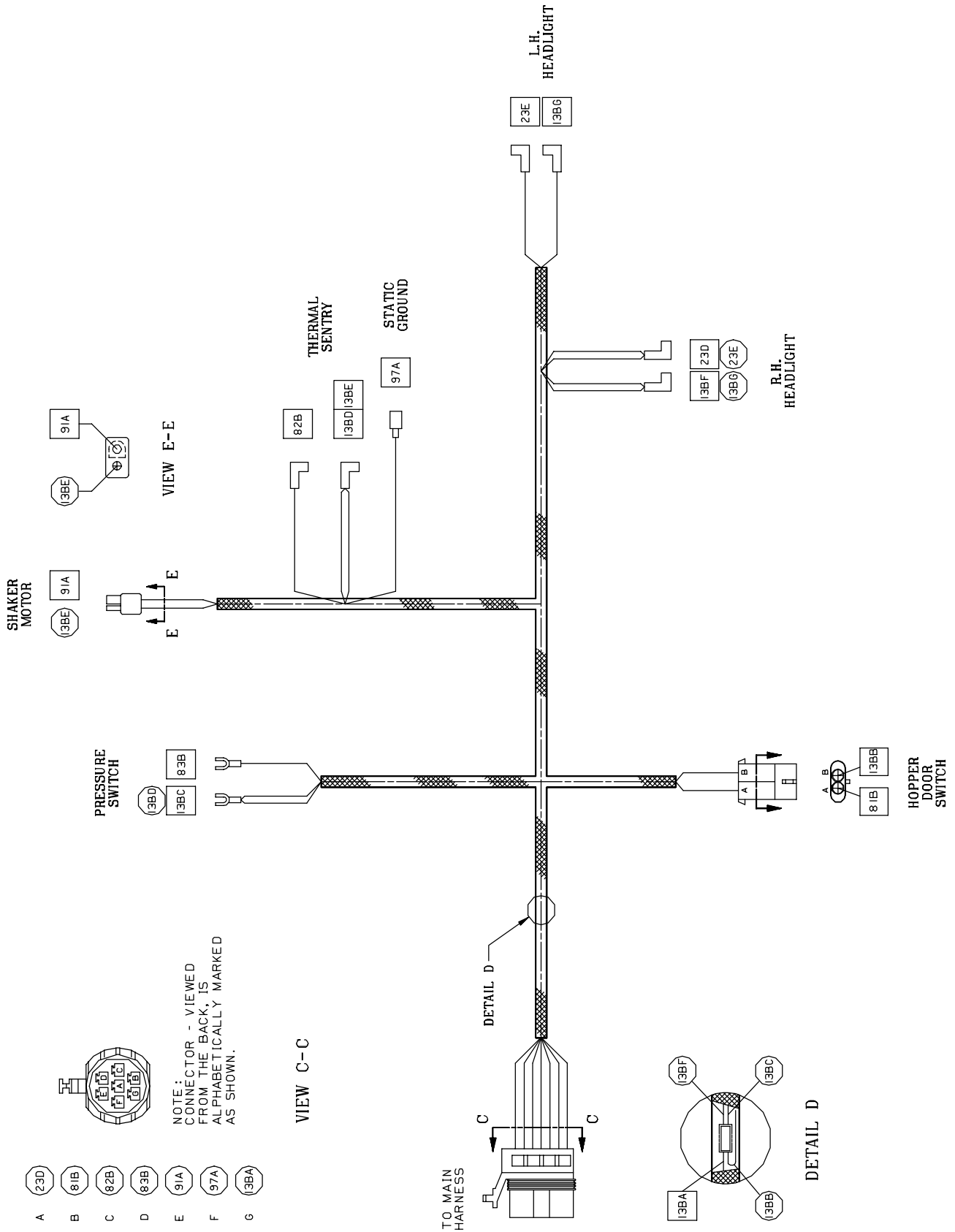

- A 23D
- B 81B
- C 82B
- D 83B
- E 91A
- F 97A
- G 135A

MAIN WIRE HARNESS DIAGRAM

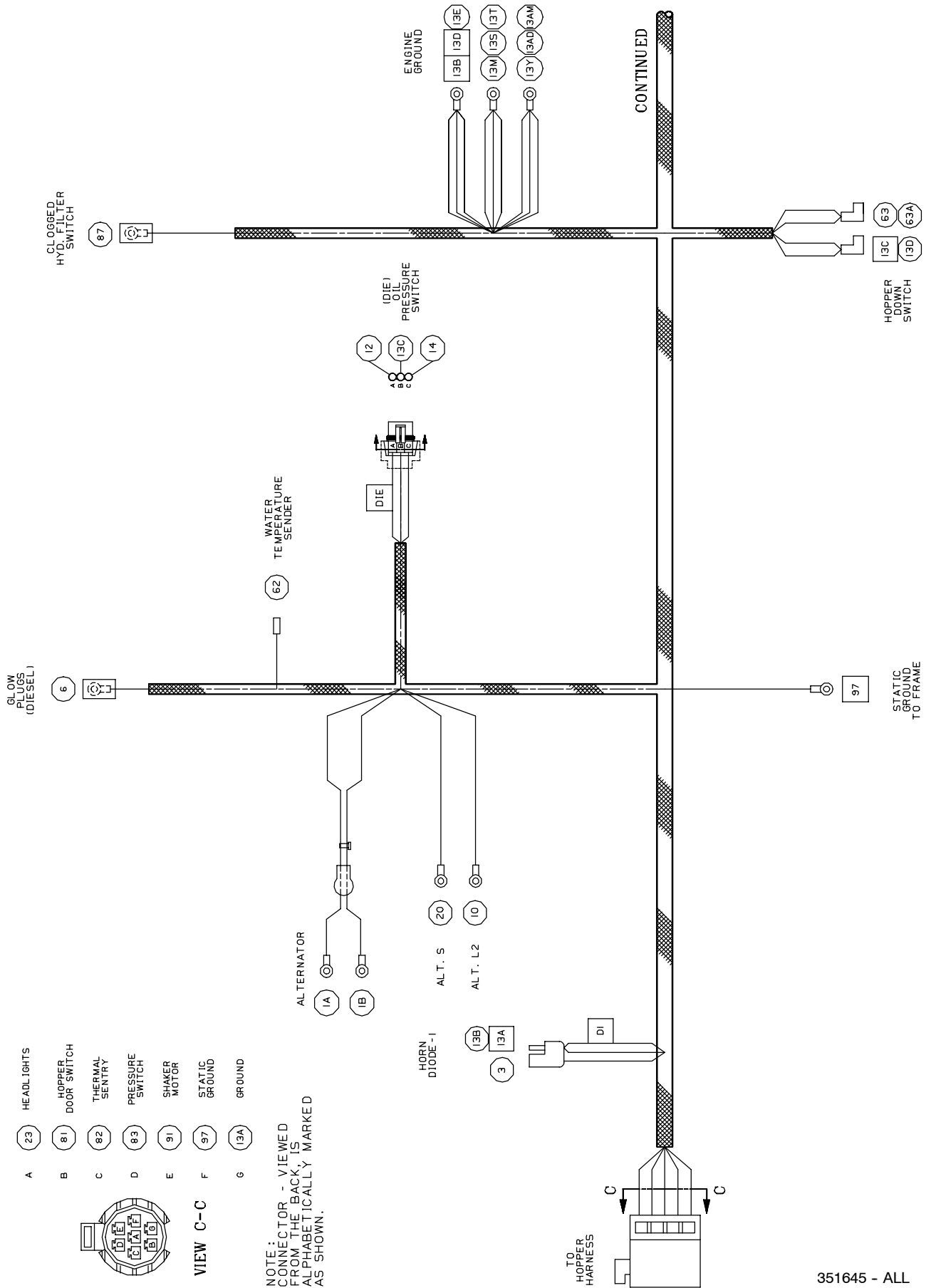

NOTE: CONNECTOR - VIEWED FROM THE BACK, IS ALPHABETICALLY MARKED AS SHOWN.

## MAIN WIRE HARNESS DIAGRAM

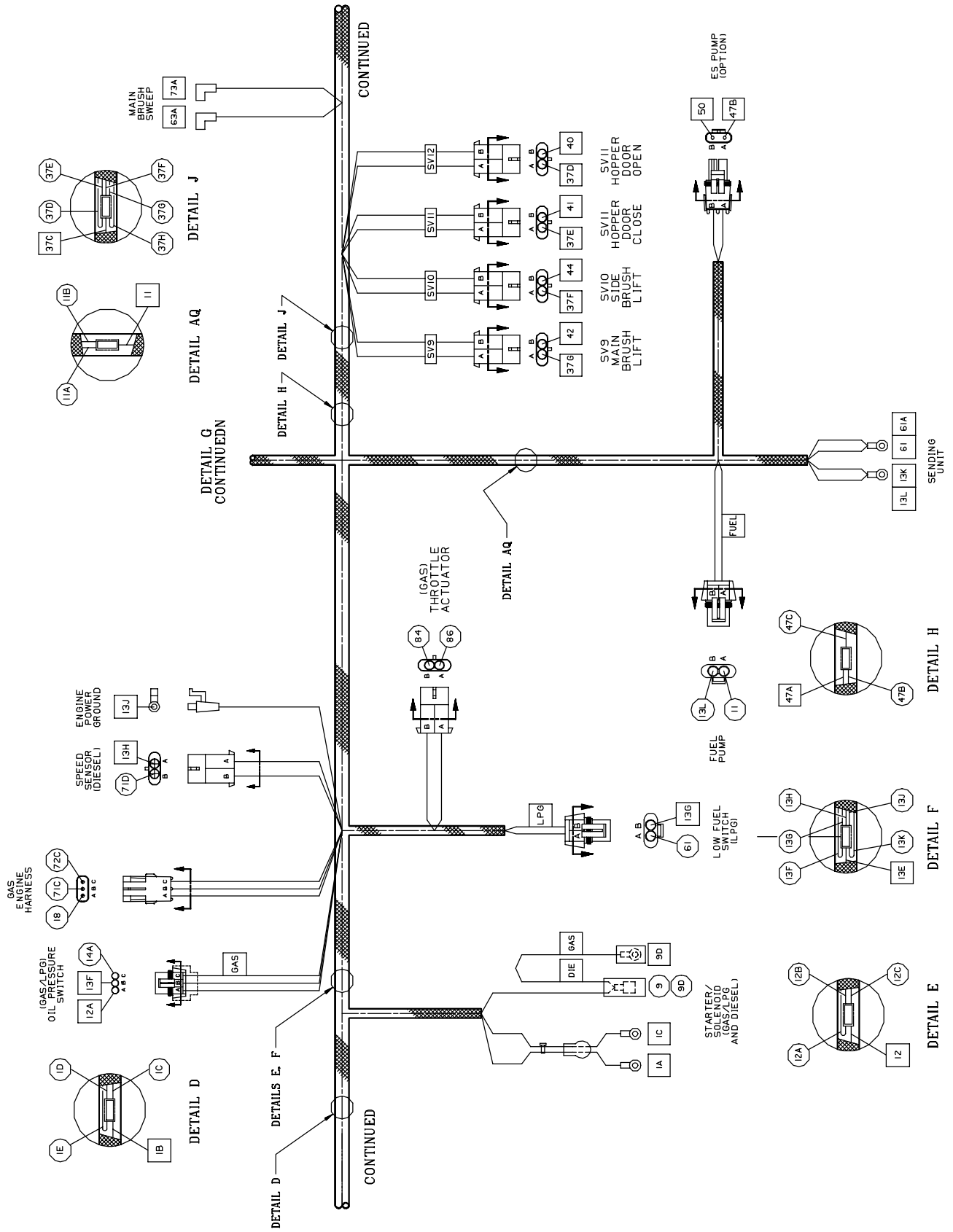

MAIN WIRE HARNESS DIAGRAM

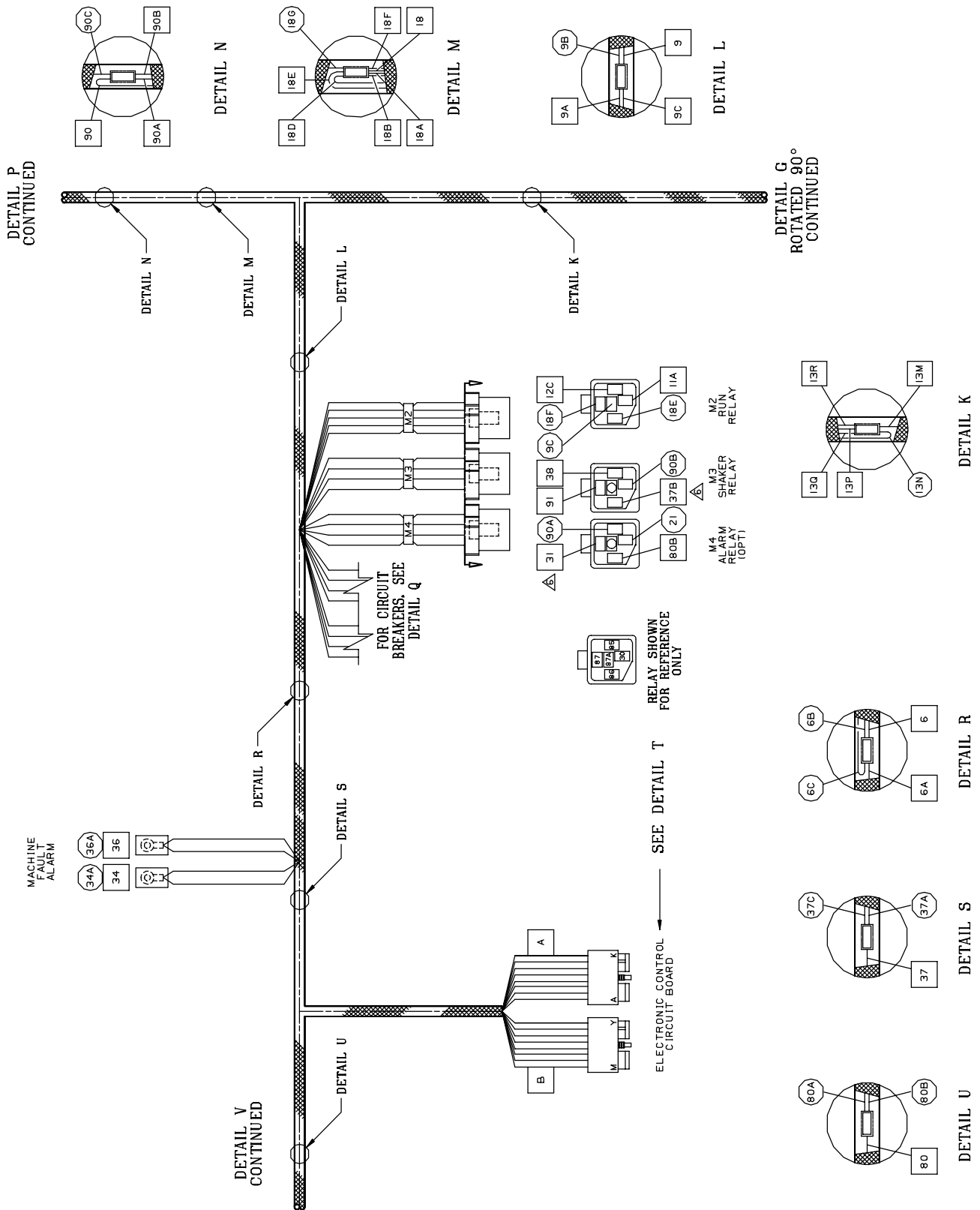

DETAIL P  
CONTINUED

DETAIL G  
ROTATED 90°  
CONTINUED

MACHINE  
FAULT  
ALARM

FOR CIRCUIT  
BREAKERS, SEE  
DETAIL Q

RELAY SHOWN  
FOR REFERENCE  
ONLY

SEE DETAIL T

ELECTRONIC CONTROL  
CIRCUIT BOARD

**MAIN WIRE HARNESS DIAGRAM**

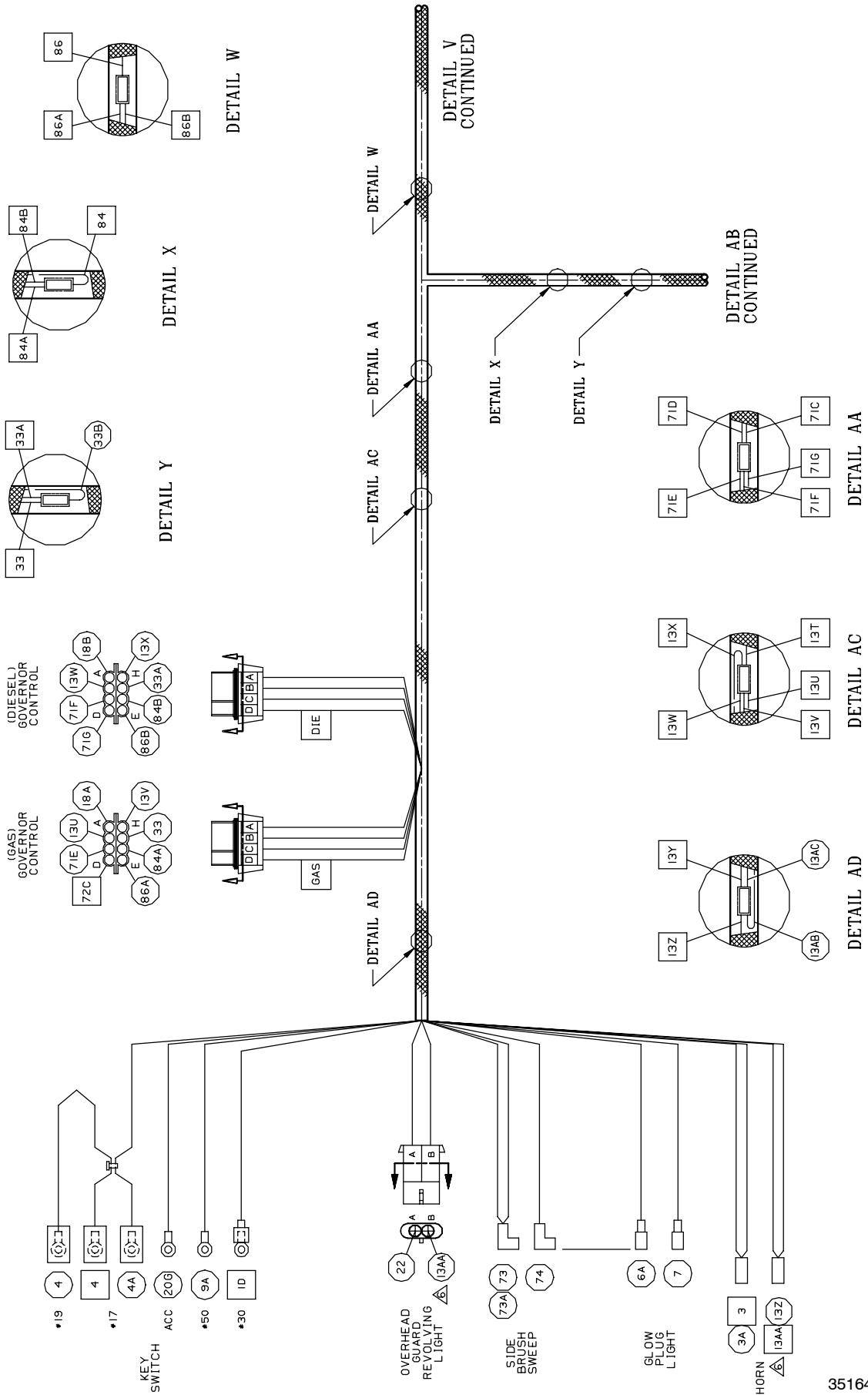

351645 - ALL



MAIN WIRE HARNESS DIAGRAM

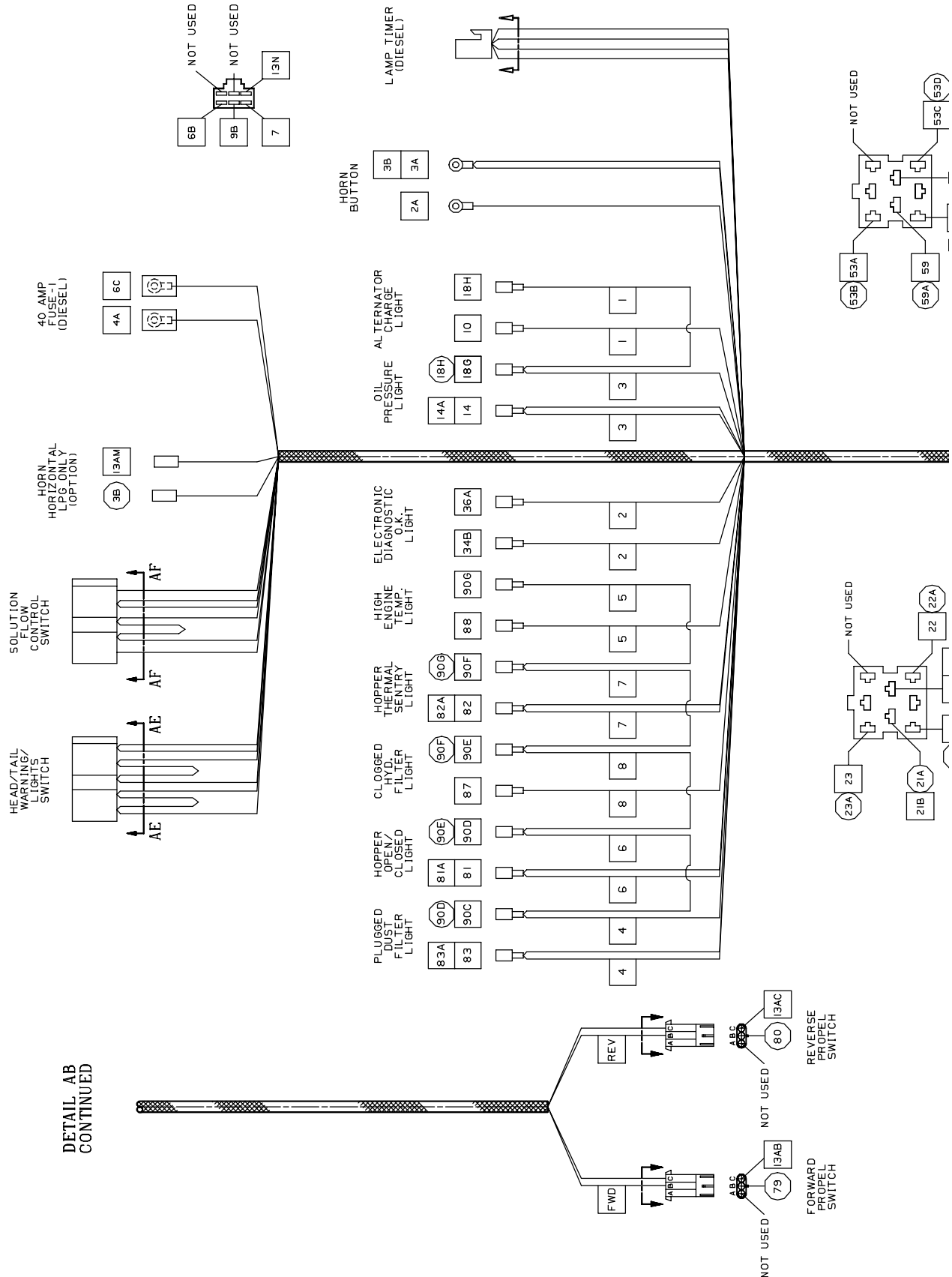

DETAIL AB CONTINUED

**MAIN WIRE HARNESS DIAGRAM**

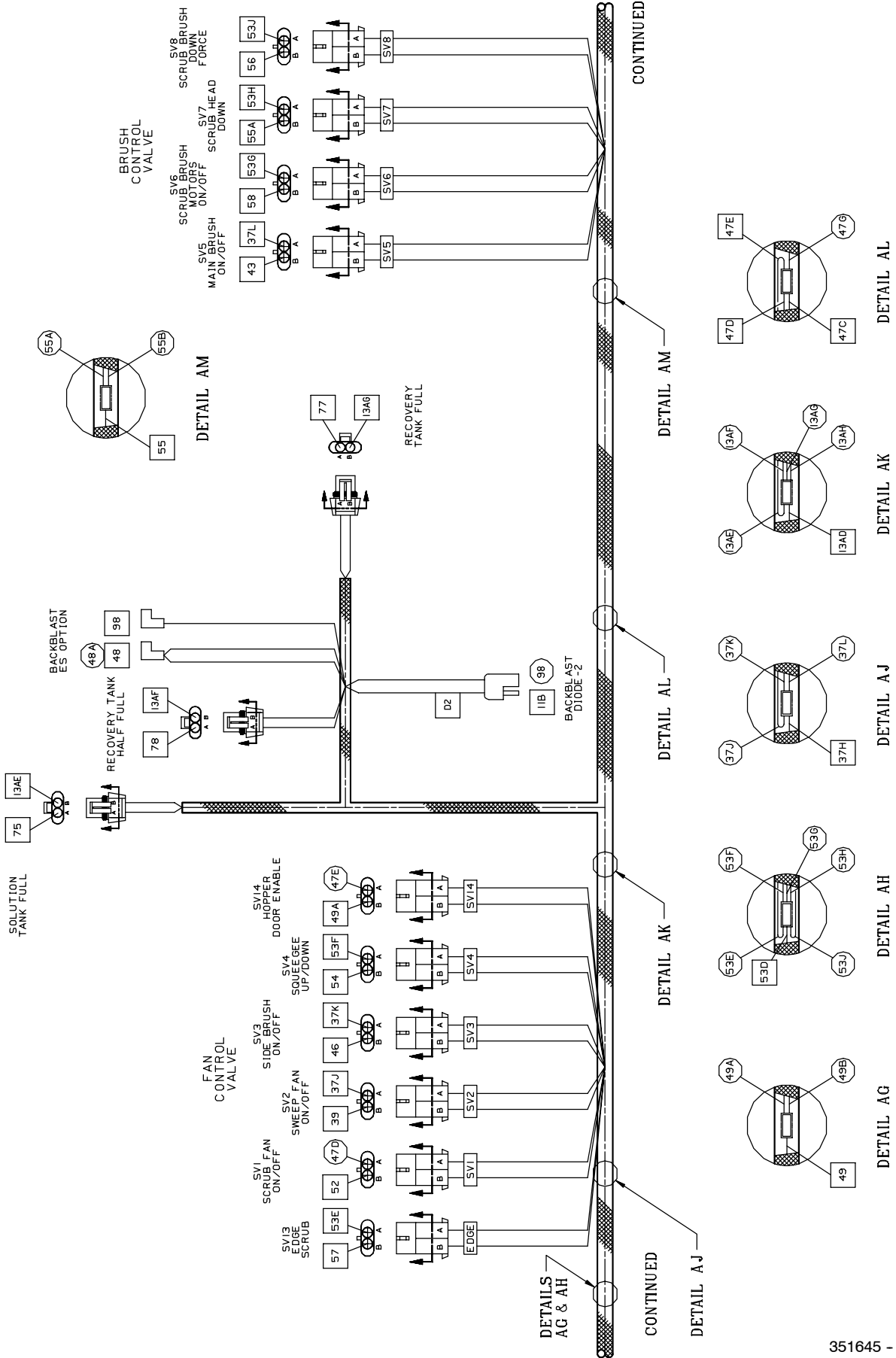

351645 - ALL

MAIN WIRE HARNESS DIAGRAM

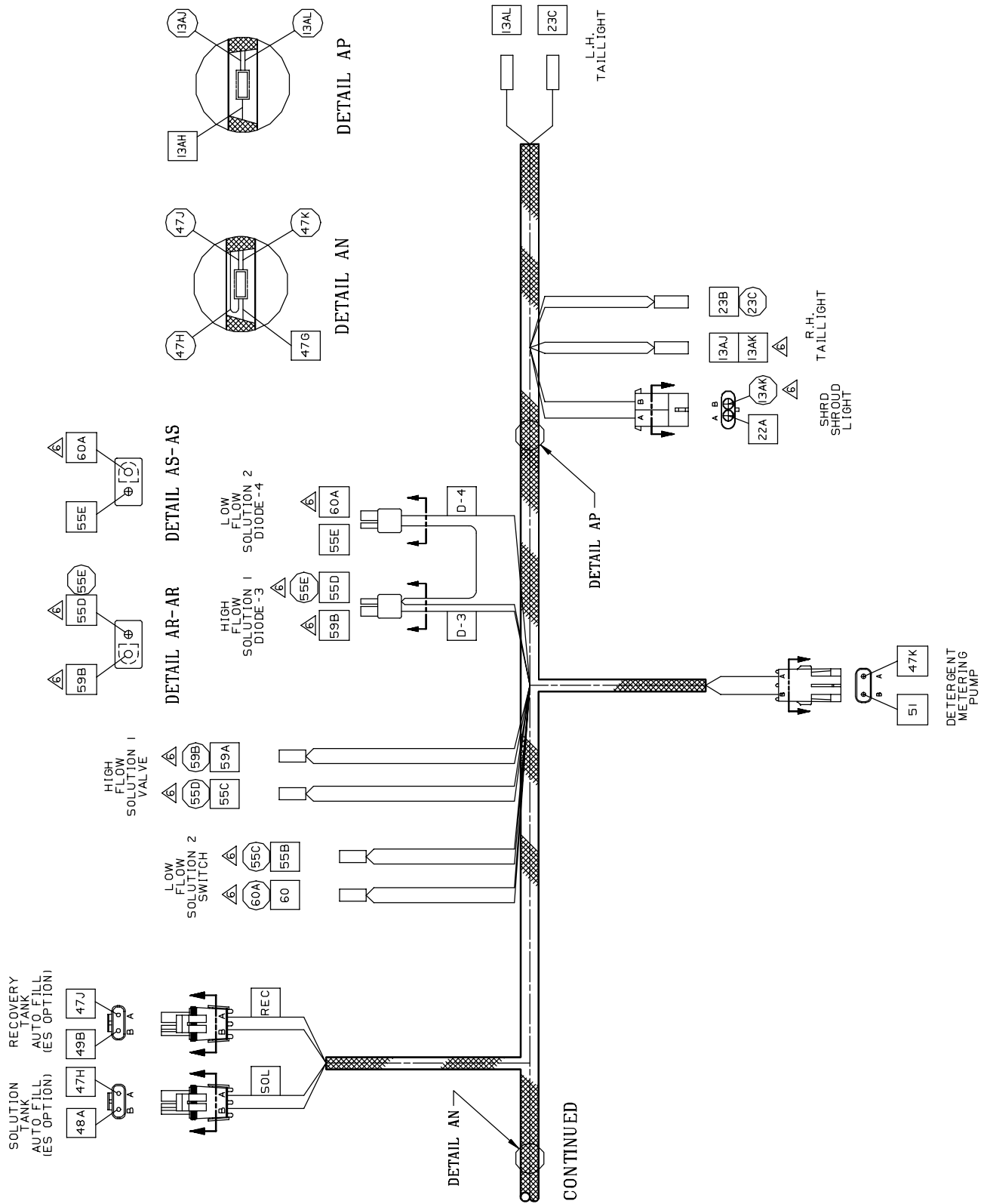

**MAIN WIRE HARNESS DIAGRAM  
DETAIL Q  
CONTINUED**

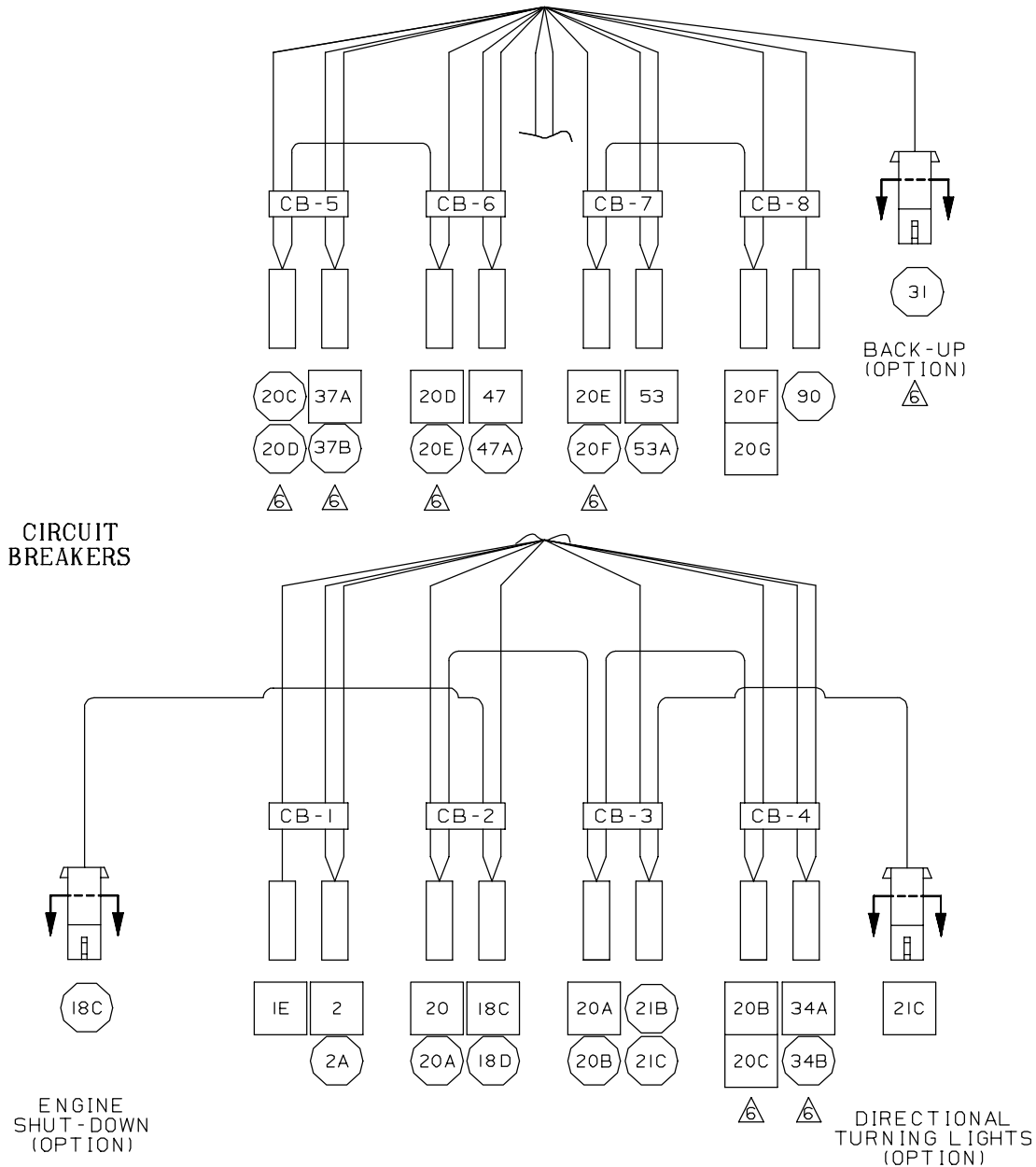

- CB-1 IGNITION AND HORN
- CB-2 RUN RELAY, FUEL PUMP, SHUTDOWN RELAY, OIL PRESSURE, IGN. COIL
- CB-3 WARNING, VEHICLE, DIRECTIONAL LIGHTS
- CB-4 MACHINE FAULT ALARM
- CB-5 SWEEP VAC FAN, HOPPER DOOR, MAIN AND SIDE BRUSHES
- CB-6 AUTOFILL, SCRUB VAC FAN, ES AND DETERGENT PUMPS
- CB-7 SWEEP SOLENOIDS
- CB-8 PLUGGED DUST FILTER, THERMAL SENTRY, CLOGGED HYD. FILTER, POWER WAND, SHAKER MOTOR

351645 - ALL

GAS/LP ENGINE WIRE HARNESS DIAGRAM (00000 - 006451)

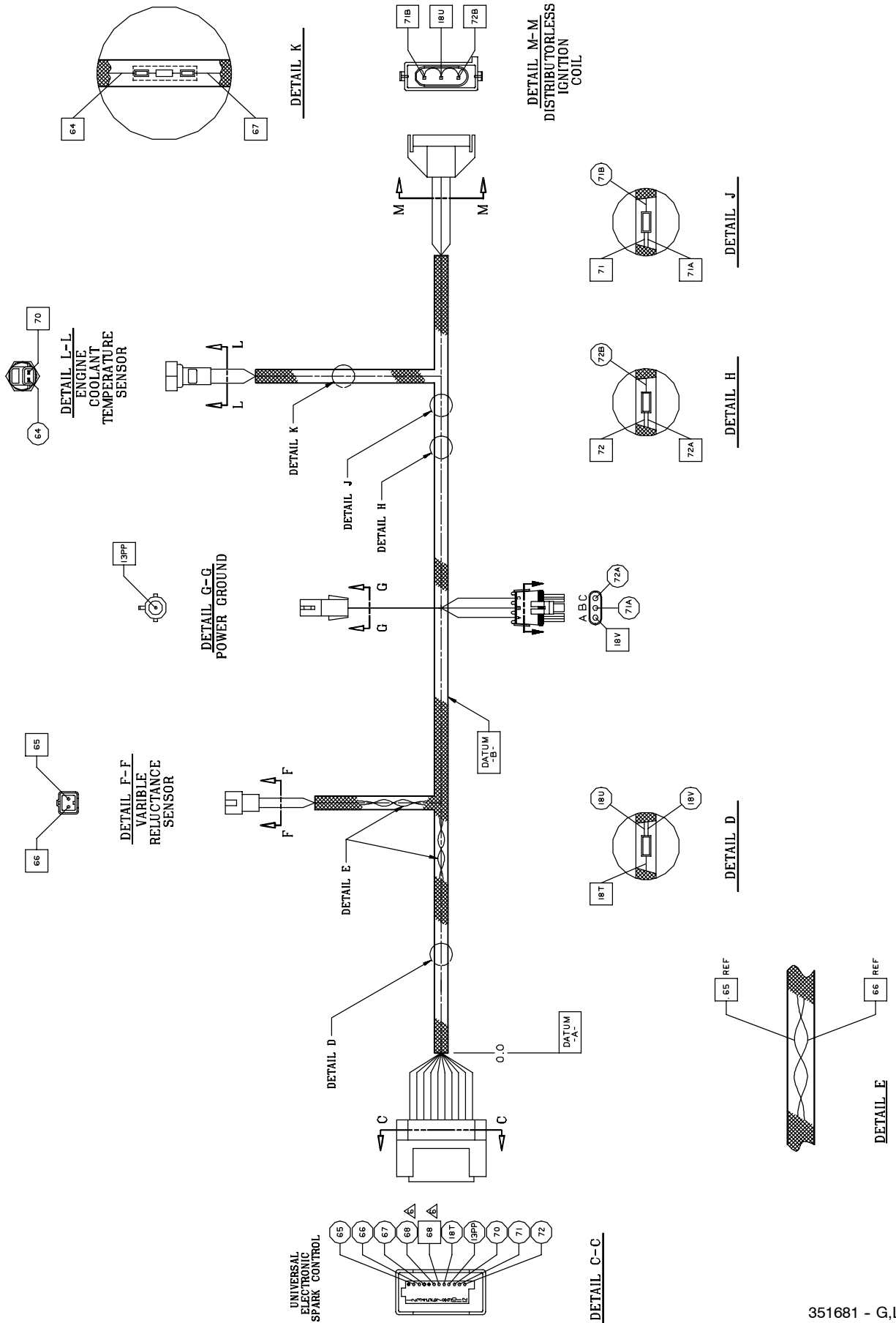

## GAS/LP ENGINE WIRE HARNESS DIAGRAM (006452 - )

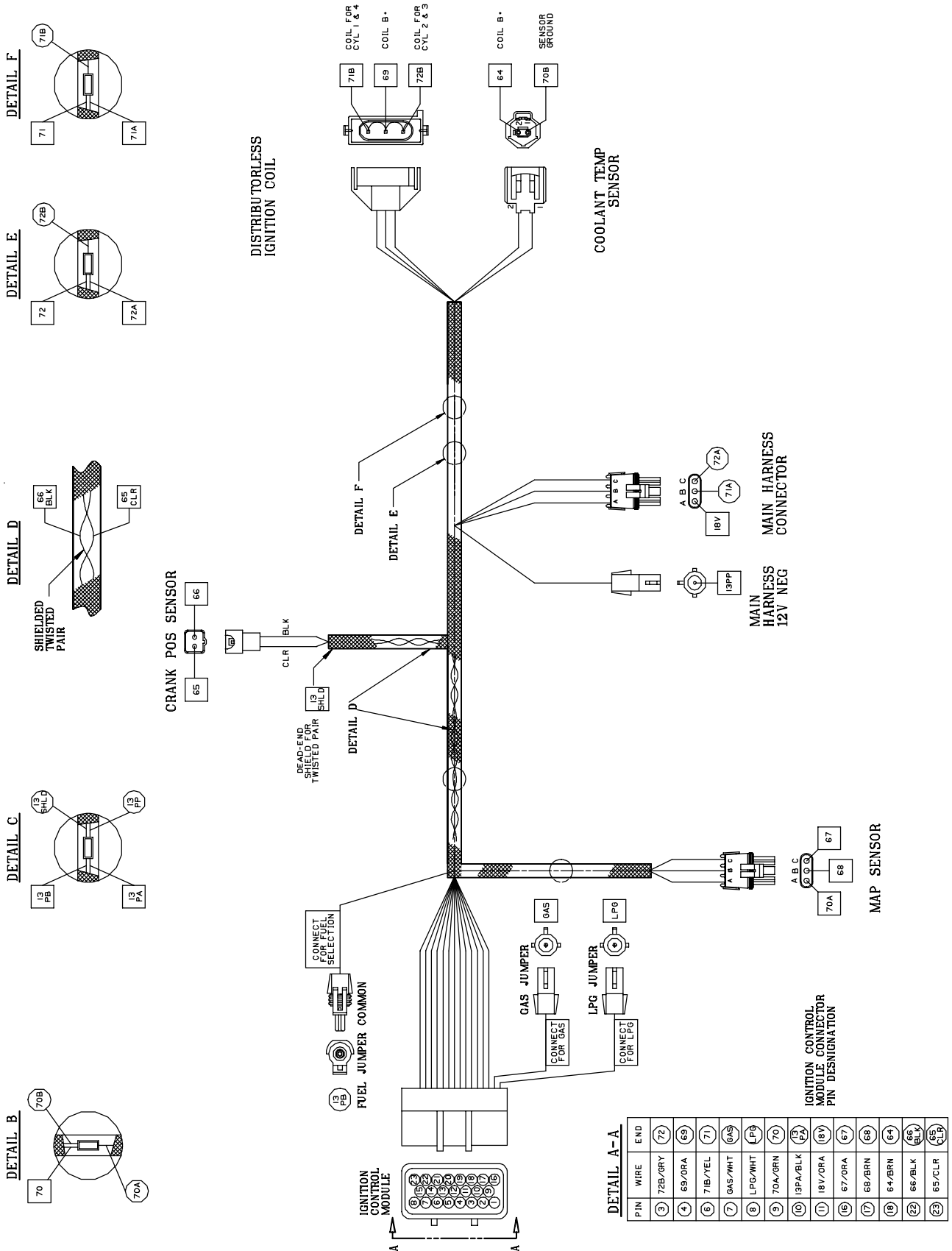

---

**DIAGNOSTICS-8200**

---

The Model 8200 has an on-board diagnostic system.

The first part of the diagnostics section describes the different operating modes that can be activated by using an entry sequence on the dash panel. There is also a chart describing the normal mode messages that may appear on the dash panel.

## OPERATING MODES

When the operator turns on the ignition key on the 8200, the control panel will perform a self test. If the self test passes, the "OK" light will turn on.

The 8200 front panel has 6 operating modes. The user can access each mode by depressing various control buttons, holding them, and turning on the key. The common operating modes are as follows:

Operating Modes	Entry Sequence (how to activate)	Indicator
<b>Normal Mode;</b> <i>Normal operation.</i> More info pages 5-52 thru 5-56	Default (when key is turned on) To exit--turn off key	● None
<b>Manual Mode;</b> <i>Manually operate discrete functions without interlocks.</i> More info pages 5-57 and 5-58	1. Push and hold the ES™ button 2. Turn on the key 3. Hold the button for 15 seconds 4. Release the ES™ button 5. To exit--turn off key	● Gas gauge 2 LED (second from left of gas gauge) blinking.
<b>Input Display Mode;</b> <i>Display the state of floats, limit switches, and sensors.</i> More info page 5-59	1. Push and hold the Scrub button 2. Turn on the key 3. Hold the Scrub button for 15 seconds 4. Release the Scrub button 5. To exit--turn off key	● Gas gauge 3 LED (third from left of gas gauge) blinking.
<b>Error Display Mode;</b> <i>Display the cause of a self test failure.</i> More info page 5-60	1. Push and hold the Detergent button 2. Turn on the key 3. Hold the Detergent button for 15 seconds 4. Release the Detergent button 5. To exit--turn off key	● Gas gauge 1 LED (far left gas gauge LED) blinking.
<b>Pressure Adjust Mode;</b> <i>Adjust pressure levels for the three down pressure settings.</i> More info page 5-61	1. Push and hold the Edge Scrub button 2. Turn on the key 3. Hold the Edge Scrub button for 15 seconds 4. Release the Edge Scrub button 5. To exit--turn off key	● Edge scrub LED's blinking.
<b>Reset Scrub Pressures;</b> <i>Return the down pressure settings to the factory defaults.</i> More info page 5-62	1. Push and hold the Fan button 2. Turn on the key 3. Hold the Fan button for 15 seconds (down press lights will start to blink) 4. While holding the Fan button, press the Edge Scrub button (down pressure lights will stop blinking) 5. Release the Fan and Edge Scrub buttons (down pressure lights may begin blinking again) 6. Turn off key 7. Restart the machine	● None



**INTERLOCKS**

The operator can start and stop the various functions of the 8200 using a variety of switch closures and interlocks. What follows are two tables for each of the basic functions. One table lists the action that are required for the basic function to be running. The other table lists the actions that would prevent the operation from running. *If the operator satisfies all of the requirements from the first table, and none of the situations of the second table exist, the operator could expect the function to operate.*

**SCRUB BRUSH OPERATION ENABLED**

Scrub brush operation enabled by:	Indicator
<ul style="list-style-type: none"> <li>Scrub button</li> </ul>	<ul style="list-style-type: none"> <li>One or more scrub pressure LED's are on</li> </ul>
<ul style="list-style-type: none"> <li>Forward propel</li> </ul>	<ul style="list-style-type: none"> <li>Forward limit switch engaged</li> </ul>

**SCRUB BRUSH OPERATION INHIBITED**

Scrub brush operation inhibited by:	Indicator
<ul style="list-style-type: none"> <li>Scrub button</li> </ul>	<ul style="list-style-type: none"> <li>All scrub pressure LED's are off</li> </ul>
<ul style="list-style-type: none"> <li>Neutral or Reverse</li> </ul>	<ul style="list-style-type: none"> <li>Forward limit switch disengaged</li> </ul>
<ul style="list-style-type: none"> <li>Full recovery tank</li> </ul>	<ul style="list-style-type: none"> <li>Recovery tank full LED on</li> </ul>

**SQUEEGEE AND VACUUM FAN OPERATION ENABLED**

Squeegee operation enabled by:	Indicator
<ul style="list-style-type: none"> <li>Scrub button or Squeegee button</li> </ul>	<ul style="list-style-type: none"> <li>Squeegee LED is on</li> </ul>
<ul style="list-style-type: none"> <li>Forward or Neutral</li> </ul>	<ul style="list-style-type: none"> <li>Reverse limit switch disengaged</li> </ul>

**SQUEEGEE AND VACUUM FAN OPERATION INHIBITED**

Squeegee operation inhibited by:	Indicator
<ul style="list-style-type: none"> <li>Scrub button or Squeegee button</li> </ul>	<ul style="list-style-type: none"> <li>Squeegee LED is off</li> </ul>
<ul style="list-style-type: none"> <li>Reverse</li> </ul>	<ul style="list-style-type: none"> <li>Reverse limit switch engaged</li> </ul>
<ul style="list-style-type: none"> <li>Full recovery tank</li> </ul>	<ul style="list-style-type: none"> <li>Recovery tank full LED blinking</li> </ul>

**ES™ PUMP OPERATION ENABLED**

ES™ pump operation enabled by:	Indicator
<ul style="list-style-type: none"> <li>ES™ button</li> </ul>	<ul style="list-style-type: none"> <li>ES™ LED is on</li> </ul>
<ul style="list-style-type: none"> <li>ES™ float covered, or ES™ 30 second timer running. The ES™ 30 second timer starts when the ES™ pump brings the solution level below the ES™ float.</li> </ul>	<ul style="list-style-type: none"> <li>None</li> </ul>

## ELECTRICAL

### ES™ PUMP OPERATION INHIBITED

ES™ pump operation inhibited by:	Indicator
<ul style="list-style-type: none"> <li>• ES™ button</li> </ul>	<ul style="list-style-type: none"> <li>• ES™ LED is off</li> </ul>
<ul style="list-style-type: none"> <li>• More than 30 seconds has passed since the ES™ float has become uncovered</li> </ul>	<ul style="list-style-type: none"> <li>• None</li> </ul>
<ul style="list-style-type: none"> <li>• Solution Tank Full float covered for more than 5 seconds</li> </ul>	<ul style="list-style-type: none"> <li>• None</li> </ul>

### SWEEP BRUSH OPERATION ENABLED

Sweep brush operation enabled by:	Indicator
<ul style="list-style-type: none"> <li>• Sweep limit switch</li> </ul>	<ul style="list-style-type: none"> <li>• Sweep lever in down position</li> </ul>

### SWEEP BRUSH OPERATION INHIBITED

Sweep brush operation inhibited by:	Indicator
<ul style="list-style-type: none"> <li>• Sweep limit switch</li> </ul>	<ul style="list-style-type: none"> <li>• Sweep lever in up position</li> </ul>
<ul style="list-style-type: none"> <li>• Hopper down switch</li> </ul>	<ul style="list-style-type: none"> <li>• Hopper up</li> </ul>

### SWEEP FAN OPERATION ENABLED

Sweep fan operation enabled by:	Indicator
<ul style="list-style-type: none"> <li>• Sweep limit switch</li> </ul>	<ul style="list-style-type: none"> <li>• Sweep lever in down position, Fan LED will turn on</li> </ul>

### SWEEP FAN OPERATION INHIBITED

Sweep fan operation inhibited by:	Indicator
<ul style="list-style-type: none"> <li>• Sweep limit switch</li> </ul>	<ul style="list-style-type: none"> <li>• Sweep lever in up position</li> </ul>
<ul style="list-style-type: none"> <li>• Pressing the Fan button</li> </ul>	<ul style="list-style-type: none"> <li>• Fan LED off</li> </ul>
<ul style="list-style-type: none"> <li>• Hopper down switch</li> </ul>	<ul style="list-style-type: none"> <li>• Hopper up</li> </ul>
<ul style="list-style-type: none"> <li>• Hopper Thermal Sentry™</li> </ul>	<ul style="list-style-type: none"> <li>• Hopper temperature light</li> </ul>
<ul style="list-style-type: none"> <li>• Shaker operation</li> </ul>	<ul style="list-style-type: none"> <li>• Shaker LED on</li> </ul>

### SIDE BRUSH OPERATION ENABLED

Side brush operation enabled by:	Indicator
<ul style="list-style-type: none"> <li>• Sweep limit switch, Side brush limit switch</li> </ul>	<ul style="list-style-type: none"> <li>• Sweep and Side brush levers must be in down position</li> </ul>

### SIDE BRUSH OPERATION INHIBITED

Side brush operation inhibited by:	Indicator
<ul style="list-style-type: none"> <li>• Sweep limit switch</li> </ul>	<ul style="list-style-type: none"> <li>• Sweep lever in up position</li> </ul>
<ul style="list-style-type: none"> <li>• Side brush limit switch</li> </ul>	<ul style="list-style-type: none"> <li>• Side brush lever in up position</li> </ul>
<ul style="list-style-type: none"> <li>• Hopper down switch</li> </ul>	<ul style="list-style-type: none"> <li>• Hopper up</li> </ul>
<ul style="list-style-type: none"> <li>• Hopper Thermal Sentry</li> </ul>	<ul style="list-style-type: none"> <li>• Hopper temperature light</li> </ul>

## ES™ AIR FLUSH OPERATION ENABLED

ES™ Air flush valve enabled by:	Indicator
<ul style="list-style-type: none"> <li>ES™ button, Squeegee button, and oil pressure</li> </ul>	<ul style="list-style-type: none"> <li>ES™ and squeegee LED's on</li> </ul>
<ul style="list-style-type: none"> <li>ES™ Air flush valve will open for a 5 second period, at a 45 second interval if both ES™ and squeegee are enabled</li> </ul>	<ul style="list-style-type: none"> <li>None</li> </ul>
<ul style="list-style-type: none"> <li>Engine on and oil pressure</li> </ul>	<ul style="list-style-type: none"> <li>Oil pressure light on</li> </ul>

## ES™ AIR FLUSH OPERATION INHIBITED

ES™ Air flush valve inhibited by:	Indicator
<ul style="list-style-type: none"> <li>ES™ button, squeegee button</li> </ul>	<ul style="list-style-type: none"> <li>ES™ or squeegee LED is off</li> </ul>
<ul style="list-style-type: none"> <li>Engine off and no oil pressure</li> </ul>	<ul style="list-style-type: none"> <li>Oil pressure light off</li> </ul>

## RECOVERY TANK AUTOFILL VALVE ENABLED

Recovery tank autofill valve enabled by:	Indicator
<ul style="list-style-type: none"> <li>ES™ float in down position</li> </ul>	<ul style="list-style-type: none"> <li>None</li> </ul>
<ul style="list-style-type: none"> <li>Machine in neutral</li> </ul>	<ul style="list-style-type: none"> <li>None</li> </ul>
<ul style="list-style-type: none"> <li>Engine off</li> </ul>	<ul style="list-style-type: none"> <li>Oil pressure light on</li> </ul>

## RECOVERY TANK AUTOFILL VALVE DISABLED

Recovery tank autofill valve disabled by:	Indicator
<ul style="list-style-type: none"> <li>ES™ float in up position</li> </ul>	<ul style="list-style-type: none"> <li>None</li> </ul>
<ul style="list-style-type: none"> <li>Machine in forward or reverse</li> </ul>	<ul style="list-style-type: none"> <li>Forward or reverse switches engaged</li> </ul>
<ul style="list-style-type: none"> <li>Engine on</li> </ul>	<ul style="list-style-type: none"> <li>Oil pressure light off</li> </ul>

## SOLUTION TANK AUTOFILL VALVE ENABLED

Solution tank autofill valve enabled by:	Indicator
<ul style="list-style-type: none"> <li>Solution tank full float in down position</li> </ul>	<ul style="list-style-type: none"> <li>None</li> </ul>
<ul style="list-style-type: none"> <li>Machine in neutral</li> </ul>	<ul style="list-style-type: none"> <li>None</li> </ul>
<ul style="list-style-type: none"> <li>Engine off</li> </ul>	<ul style="list-style-type: none"> <li>Oil pressure light on</li> </ul>

## SOLUTION TANK AUTOFILL VALVE DISABLED

Solution tank autofill valve disabled by:	Indicator
<ul style="list-style-type: none"> <li>Solution tank full float in up position</li> </ul>	<ul style="list-style-type: none"> <li>None</li> </ul>
<ul style="list-style-type: none"> <li>Machine in forward or reverse</li> </ul>	<ul style="list-style-type: none"> <li>Forward or reverse switches engaged</li> </ul>
<ul style="list-style-type: none"> <li>Engine on</li> </ul>	<ul style="list-style-type: none"> <li>Oil pressure light off</li> </ul>

## ELECTRICAL

Operating Mode	Entry Sequence (how to activate)	Indicator
<b>Normal Mode;</b> <i>Normal operation.</i>	Default (when key is turned on) To exit--turn off key	● None

### **NORMAL MODE (front panel)**

The purpose of the normal mode is for the general operation of the machine. The machine will normally start in this mode. What follows is a brief description of each of the operations in the normal mode.

#### **EDGE SCRUB BUTTON**

Pressing the Edge Scrub button will toggle the Edge Scrub LED.

If the machine is propelling forward in the scrub mode and the Edge Scrub LED is on, the scrub head will shift into the edge scrub position. If the Edge scrub LED is off, the scrub head will return to the retracted position.

#### **SQUEEGEE**

If the squeegee LED is off and the machine is not in reverse, pressing the squeegee button will drop the squeegee and turn on the vacuum fan.

If the squeegee LED is on, pressing the squeegee button will raise the squeegee, initiate a delay, and turn off the vacuum fan. Squeegee operation is inhibited in reverse.

#### **ENGINE SPEED**

If the engine is at idle speed, pressing this button will bring it to operating speed. If the scrub mode is active, pressing the engine button will cancel all scrubbing activities.

If the squeegee is down, pressing the engine button will raise the squeegee and turn off the scrub vacuum fan.

**SCRUB**

If the scrub function is currently inactive, pressing the scrub button will initiate the following actions:

1. The engine speed is set high.
2. If the machine is propelling forward, the main brushes will turn on and go down. The down pressure setting will be the same used during the last scrub cycle. The solution will flow at the high or low rate according to the water position switch.
3. If the machine is in reverse, the brushes will stay up and off.
4. If the machine goes into neutral, the brushes will stay on for a short delay, then shut off and retract.
5. If the Edge Scrub LED is on and the machine is propelling forward, the scrub head will go into the edge scrub position.
6. The scrub vacuum fan will turn on.
7. If the machine is not in reverse, the squeegee will go down.
8. If the machine is in reverse, the squeegee will stay up until reverse is no longer sensed.
9. If any of the detergent LED's are active, and the machine is propelling forward, the detergent pump will run. The detergent pump will run at its slow rate if one LED is on. The detergent pump will run at its fast rate if two LED's are on.

### SCRUB (cont...)

If the operator pushes and holds the scrub button, the pressure settings will begin to scroll. The pressure setting displayed after releasing the scrub button will become the new default down pressure setting.

If the scrub function was active and the operator pushes, then releases the scrub button, the following actions will take place:

1. The main brushes will turn off and rise.
2. The edge scrub will retract.
3. The solution flow will turn off.
4. The detergent pump will turn off.
5. A seven second delay will pass, then the squeegee will rise.
6. A four second delay will pass and the vacuum fan will turn off.

### DETERGENT

Pressing the detergent button will toggle the function on and off. Holding the detergent button will cause the display to scroll through its two speeds. The detergent pump will run only if the main scrub brushes are active and the solution switch is on.

1. Off (all LED's off)---detergent pump off.
2. Low (left LED on)----detergent pump low.
3. High (both LED's on)--detergent pump high

### ES™

Pressing the ES™ button will enable or disable the ES™ function. In order for the ES™ float to become active, it must be consistently in the up position for at least 10 seconds. If the ES™ function is enabled and the ES™ float becomes active, the following action will occur:

1. The ES™ pump will begin to run.
2. The ES™ pump will continue to run for 30 seconds after the ES™ float becomes uncovered, or until the solution tank becomes covered.

## OVER-FLOW

In order for the recovery tank float to become active, it must be consistently in the up position for at least 10 seconds. If the scrub or vacuum fan are active and the tank full float becomes active, the overflow light will come on and the scrub and squeegee functions will be canceled. The overflow light will not turn off by simply emptying the recovery tank. The scrub or squeegee buttons must be pressed, or the key switch must be cycled.

## **NORMAL MODE (side panel)**

The purpose of the normal mode is for the general operation of the machine. The machine will normally start in this mode. What follows is a brief description of each of the operations in the normal mode.

## MAIN SWEEP BRUSH

The main brush is engaged by a limit switch that senses the position of the brush handle. Engaging the main sweep brush also engages the sweep vacuum fan. The operator can cancel the vacuum fan using the panel switch.

## SIDE SWEEP BRUSH

The side brush is engaged by two limit switches that sense the positions of the side and main brush handles. When both of these handles are engaged, the side brush will turn on.

## FILTER SHAKER

The Filter Shaker button controls the operation of the filter shaker and timer system.

- If the filter shaker LED is off, pressing the shaker button will initiate a shake sequence. A shake sequence is defined as follows:
  1. The Shaker LED will turn on.
  2. The filter shaker will start.
  3. The filter shaker and LED will remain on for approximately 30 seconds.
  4. The filter shaker and LED will turn off.
  5. If the sweep fan is active, the fan will shut off during the shake cycle.
- If the Filter shaker LED is on, pressing the shaker button will turn off the Shaker motor and LED.

### VACUUM FAN

Pressing the sweep vacuum fan button will enable or disable the fan operation while sweeping.

- The fan is inhibited if the shaker is active.
- Each time the sweep function is engaged, the fan will be enabled.
- Each time the sweep function is turned off, the fan will be canceled.

### MAINTENANCE MODES

Each time the operator turns on the machine, the front panel will run an automatic self check. If the front panel passes its self test, the OK light will turn on.

The 8200 front panel has a total of six operating modes. When the operator starts the machine, the panel will run its self test, then return to the normal operating mode. The operator can access five maintenance modes by turning the machine off, pressing and holding the appropriate button, turning the machine on, and holding the button for about 15 seconds.

The following pages include brief descriptions of how to enter each of the maintenance modes, and how the machine will function in that mode.



Operating Mode	Entry Sequence (how to activate)	Indicator
<b>Manual Mode;</b> <i>Manually operate discrete functions without interlocks.</i>	<ol style="list-style-type: none"> <li>1. Push and hold the ES™ button</li> <li>2. Turn on the key</li> <li>3. Hold the button for 15 seconds</li> <li>4. Release the ES™ button</li> <li>5. To exit--turn off key</li> </ol>	<ul style="list-style-type: none"> <li>● Gas gauge 2 LED (second from left of gas gauge) blinking.</li> </ul>

## MANUAL MODE

In this mode, the operator can turn on and off accessories individually and manually. In the manual mode, the operator can turn on accessories without regard to inputs or interlocks. If, for instance, the operator enables the ES™ pump in the manual mode, it will run regardless of whether or not the ES™ float is in the water.

- TO INITIATE:

1. Turn off the machine.
2. Press and hold the ES™ button.
3. Turn on the machine.
4. Hold the ES™ button for 15 seconds.
5. Release the ES™ button.

- OPERATION:

- ES™: *Pressing the ES™ button in the manual mode turns on and off the ES™ pump. The air flush valve will turn on and off at 5 second intervals if the oil pressure light is off.*
    - EDGE SCRUB BUTTON: *Pressing the Edge Scrub button will extend or retract the scrub head.*
    - SQUEEGEE BUTTON: *Pressing the Squeegee button will turn on the vacuum fan and lower the squeegee. Reverse is ignored.*
    - ENGINE BUTTON: *Pressing the Engine button will toggle the engine between high and low speed.*

Continued on next page.....

Continued from previous page....

■ **OPERATION:**

- **SCRUB BUTTON:** *Pressing the Scrub button will turn on and lower the main scrub head. Holding the Scrub button while scrub is active will cause the down pressures to scroll.*
- **DETERGENT BUTTON:** *Pressing the Detergent button will cause the detergent LED's to scroll. If no LED's are on, the detergent pump will be off. If one LED is illuminated, the detergent pump will run in low speed. If both LED's are on, the detergent pump will run in high speed.*
- **FAN BUTTON:** *Pressing the Fan button will turn on the sweep fan regardless of the hopper down or the hopper fire switches.*
- **SHAKE BUTTON:** *Pressing the Shake button will turn on the shaker.*

Operating Mode	Entry Sequence (how to activate)	Indicator
<b>Input Display Mode;</b> <i>Display the state of floats, limit switches, and sensors.</i>	<ol style="list-style-type: none"> <li>1. Push and hold the Scrub button</li> <li>2. Turn on the key</li> <li>3. Hold the Scrub button for 15 seconds</li> <li>4. Release the Scrub button</li> <li>5. To exit--turn off key</li> </ol>	<ul style="list-style-type: none"> <li>• Gas gauge 3 LED (third from left of gas gauge) blinking.</li> </ul>

### INPUT DISPLAY MODE

In this mode, the operator can observe whether or not inputs to the panel are operating as intended. In the Input display mode, the LED's on the instrument panel display the state of each input. If an input is open, the controller turns off the LED associated with that input. If an input is shorted to ground, the controller turns on the LED associated with that input.

- TO INITIATE:

1. Turn off the machine.
2. Press and hold the Scrub button.
3. Turn on the machine.
4. Hold the Squeegee button until the gas gauge light #3 (3rd from left) begins to blink.
5. Release the Scrub button.

PANEL LED	INPUT SIGNAL
ES™ LED	ES™ FLOAT
OVERFLOW LED	FULL RECOVERY TANK
LEFT BRUSH PRESSURE LED	REVERSE
RIGHT BRUSH PRESSURE LED	FORWARD
SHAKER LED	PLUGGED DUST FILTER
FAR LEFT GAS GAUGE LED	SIDE BRUSH LIMIT SWITCH
SECOND GAS GAUGE LED FROM LEFT	MAIN SWEEP LIMIT SWITCH
FAR LEFT DETERGENT LED	SOLUTION FULL FLOAT
FAR RIGHT DETERGENT LED	SOLUTION FLOW SWITCH
FAR RIGHT GAS LED	HOPPER DOWN SWITCH
SWEEP FAN LED	HOPPER THERMAL SENTRY™

## ELECTRICAL

Operating Mode	Entry Sequence (how to activate)	Indicator
<b>Error Display Mode;</b> <i>Display the cause of a self test failure.</i>	<ol style="list-style-type: none"> <li>1. Push and hold the Detergent button</li> <li>2. Turn on the key</li> <li>3. Hold the Detergent button for 15 seconds</li> <li>4. Release the Detergent button</li> <li>5. To exit--turn off key</li> </ol>	<ul style="list-style-type: none"> <li>● Gas gauge 1 LED (far left gas gauge LED) blinking.</li> </ul>

### ERROR DISPLAY MODE

Each time the operator starts the machine, the panel will run a self test on each output. If the panel passes the diagnostic, the OK indicator is illuminated. If the panel fails, a code is stored. In the Error Display Mode, the operator can obtain the error code stored after the last startup diagnostic failure. When the machine is in this mode, the LED's on the operator's panel will indicate which system experienced the failure. The operator should then unplug the offending device, and cycle the key switch on the machine. If the OK light now comes on, it is likely that the device that was unplugged was shorted.

- TO INITIATE:

1. Turn off the machine.
2. Press and hold the Detergent button.
3. Turn on the machine.
4. Hold the Detergent button for 15 seconds.
5. Release the Detergent button.

DIAGNOSTIC FAILURE	PANEL LED
SOLUTION FILL/BACK FLUSH VALVES	LEFT DETERGENT LED
RECOVERY TANK FILL/HOPPER DOOR ENABLE VALVES	OVERFLOW LED
SWEEP FAN VALVE	SWEEP FAN LED
SHAKER MOTOR RELAY	SHAKER LED
ES™ PUMP DRIVE	ES™ LED
DETERGENT PUMP DRIVE	RIGHT DETERGENT LED
SCRUB BRUSH VALVE	LEFT SCRUB PRESSURE LED
SCRUB BRUSH PRESSURE VALVE	CENTER SCRUB PRESSURE LED
SCRUB FAN VALVE	LEFT ENGINE SPEED LED
SQUEEGEE VALVE	SQUEEGEE LED
EDGE SCRUB VALVE	EDGE LED
SCRUB BRUSH DOWN VALVE	RIGHT SCRUB PRESSURE LED

Operating Mode	Entry Sequence (how to activate)	Indicator
<b>Pressure Adjust Mode;</b> <i>Adjust pressure levels for the three down pressure settings.</i>	<ol style="list-style-type: none"> <li>1. Push and hold the Edge Scrub button</li> <li>2. Turn on the key</li> <li>3. Hold the Edge Scrub button for 15 seconds</li> <li>4. Release the Edge Scrub button</li> <li>5. To exit--turn off key</li> </ol>	<ul style="list-style-type: none"> <li>● Edge scrub LED's blinking.</li> </ul>

## PRESSURE ADJUST MODE

When the machine is in this mode, the operator can adjust the down pressures for the main brush. The operator may make independent adjustments to pressures 1, 2, and 3. The operator can change the pressure settings by pressing and holding the scrub button. After each adjustment, the new pressure setting is stored in non-volatile (retained even after power down) memory.

- TO INITIATE:

1. Turn off the machine.
2. Press and hold the Edge Scrub button.
3. Turn on the machine.
4. Hold the Edge Scrub button for 15 seconds, until the maintenance light comes on.
5. Release the Side brush button. The Edge LED will start to blink.

- **SCRUB BUTTON:**

Pressing the Scrub button will start the normal scrub sequence. When scrub is active, the following controls and displays take on alternate functions:

- **GAS GAUGE:** *For the pressure adjust mode, the gas gauge displays the current to the down pressure valve. Gas gauge LED's 1, 2, and 3 correspond to factory settings for normal down pressures.*

- **SQUEEGEE BUTTON:** *Holding the squeegee button will decrease the down pressure.*

- **DETERGENT BUTTON:** *Holding the detergent button will increase the down pressure.*

## ELECTRICAL

Operating Mode	Entry Sequence (how to activate)	Indicator
<b>Reset Scrub Pressures;</b> <i>Return the down pressure settings to the factory defaults.</i>	<ol style="list-style-type: none"><li>1. Push and hold the Fan button</li><li>2. Turn on the key</li><li>3. Hold the Fan button for 15 seconds (down press lights will start to blink)</li><li>4. While holding the Fan button, press the Edge Scrub button (down pressure lights will stop blinking)</li><li>5. Release the Fan and Edge Scrub buttons</li><li>6. Turn off key</li><li>7. Restart the machine</li></ol>	● None

### RESET SCRUB PRESSURE

When the machine goes into this mode, the controller replaces the current brush down pressure settings with factory defaults.

● TO INITIATE:

1. Turn off the machine.
2. Press and hold the Sweep Fan button.
3. Turn on the machine.
4. Hold the Sweep Fan button for 15 seconds.
5. Release the Fan and Edge scrub buttons.

---

**DIAGNOSTICS-8210**

---

The Model 8210 has an on-board diagnostic system.

The first part of the diagnostics section describes the different operating modes that can be activated by using an entry sequence on the dash panel. There is also a chart describing the normal mode messages that may appear on the dash panel.

## OPERATING MODES

---

The sweep and scrub functions of the 8210 are controlled using a touch panel with two dedicated buttons, and 6 multi-function buttons. The multi-function buttons surround a graphics display panel. Images on the display panel identify the current function of the six buttons.

The intent of the system is to offer one button sweeping and scrubbing, while reducing the number of controls confronting the operator. This is accomplished by using multi-function buttons. This system is designed to offer the operator control of the functions which are appropriate for the current task. An example would be the operation of the hopper door. If the operator is sweeping, the hopper door will automatically open. It would be inappropriate for the operator to close the door while sweeping, so none of the multi-function switches are assigned to the hopper door. If the operator lifts the hopper (presumably to dump), the operator needs to have control of the hopper door. The door icon will appear on the screen, and one of the six multi-function switches will be assigned the function of opening or closing the door.

The 8210 has 5 operating, and 7 maintenance modes. The operating modes are engaged using the 6 multi-function buttons. The button which is inside the Tennant logo (logo button) will scroll the machine through the various operating modes without engaging any functions. The maintenance modes are enabled by pressing the logo button, turning on the machine, waiting 15 seconds, and releasing the logo button. Maintenance modes can then be chosen using the multi-function buttons.



## FRONT PANEL OPERATING MODES

OPERATING MODE	ENTRY SEQUENCE	FUNCTIONS AVAILABLE	DESCRIPTION
● IDLE MODE	1. This is the mode in which the panel will normally power up.	1. Scrub 2. No function 3. Squeegee 4. Sweep 5. No function 6. No function	This mode gives the operator the basic, sweep, scrub, and water pickup modes.
● SCRUB MODE	1. Pressing the scrub button from the idle mode. 2. Pressing the logo button from the idle mode.	1. Scrub 2. Edge scrub 3. Squeegee 4. Sweep 5. Detergent metering 6. ES™ function	This mode gives the operator control of all scrub functions.
● SWEEP MODE	1. Pressing the sweep button from the idle mode. 2. Pressing the logo button from the scrub mode.	1. Scrub 2. Filter shaker 3. Squeegee 4. Sweep 5. Side brush 6. Sweep fan	This mode gives the operator control of all sweep functions.
● HOPPER UP MODE	1. Lifting the hopper (releasing the hopper down switch). 2. Pressing the logo button from the sweep mode.	1. Scrub 2. Filter shaker 3. Squeegee 4. No function 5. No function 6. Hopper door	This mode gives the operator control of the hopper door.
● SWEEP/SCRUB MODE	1. Pressing the scrub button while in the sweep mode. 2. Pressing the sweep button while in the scrub mode.	1. Scrub 2. Edge scrub 3. Squeegee 4. Sweep 5. Side brush 6. Sweep fan	This mode gives the operator control of the primary sweep controls, and the three primary scrub controls.

# ELECTRICAL

## FRONT PANEL MAINTENANCE MODES

MAINTENANCE MODE	ENTRY SEQUENCE	FUNCTIONS AVAILABLE	DESCRIPTION
● MAINTENANCE 1 MODE	<ol style="list-style-type: none"> <li>1. Hold logo key</li> <li>2. Turn machine on</li> <li>3. Hold logo key for 15 seconds</li> <li>4. Release logo key</li> </ol>	<ol style="list-style-type: none"> <li>1. Down pressure reset</li> <li>2. Down pressure adjust</li> <li>3. Manual mode</li> <li>4. No function</li> <li>5. No function</li> <li>6. No function</li> </ol>	This mode allows the operator to choose from the first three maintenance modes.
● MAINTENANCE 2 MODE	<ol style="list-style-type: none"> <li>1. Hold logo key</li> <li>2. Turn machine on</li> <li>3. Hold logo key for 15 seconds</li> <li>4. Release logo key</li> <li>5. Press and release logo key.</li> </ol>	<ol style="list-style-type: none"> <li>1. Input display mode</li> <li>2. Enable Edge Scrub mode</li> <li>3. Time adjust mode</li> <li>4. No function</li> <li>5. No function</li> <li>6. No function</li> </ol>	This mode allows the operator to choose from the second three maintenance modes.
● MAINTENANCE 3 MODE	<ol style="list-style-type: none"> <li>1. Hold logo key</li> <li>2. Turn machine on</li> <li>3. Hold logo key for 15 seconds</li> <li>4. Release logo key</li> <li>5. Press and release logo key 2 times.</li> </ol>	<ol style="list-style-type: none"> <li>1. Self Test mode</li> <li>2. Check maint. mode</li> <li>3. Enable maint. mode</li> <li>4. No function</li> <li>5. No function</li> <li>6. No function</li> </ol>	This mode allows the operator to choose from the last two maintenance modes, or exiting to the idle mode.
● MAINTENANCE 4 MODE	<ol style="list-style-type: none"> <li>1. Hold logo key</li> <li>2. Turn machine on</li> <li>3. Hold logo key for 15 seconds</li> <li>4. Release logo key</li> <li>5. Press and release logo key 3 times.</li> </ol>	<ol style="list-style-type: none"> <li>1. Language select</li> <li>2. No function</li> <li>3. No function</li> <li>4. No function</li> <li>5. No function</li> <li>6. Exit to normal mode</li> </ol>	Pressing button 1 will cause the machine to scroll through the different language options. The software rev level is displayed near switch 2.
● MANUAL MODE "MAN" INDICATED ON GRAPHIC DISPLAY	Select Manual Mode from Maintenance 1 screen	Operator can use the logo button to scroll through the various operating modes and select individual functions.	Manually operate discrete functions without interlocks.

## FRONT PANEL MAINTENANCE MODES

MAINTENANCE MODE	ENTRY SEQUENCE	FUNCTIONS AVAILABLE	DESCRIPTION
● INPUT DISPLAY MODE	Select the Input Display mode from the Maintenance 2 screen		Display the state of floats, limit switches, and sensors. This mode enables a special display that indicates the various float and input switch levels. The operator can operate the machine in input display mode by scrolling to the operating modes, engaging the desired functions, and scrolling back to the input display mode.
● SELF TEST MODE	Select the Self Test mode from the maintenance 3 screen		This function tests the output portion of the controller board.
● PRESSURE ADJUST MODE	Select the Pressure Adjust mode from the maintenance 1 screen	<ol style="list-style-type: none"> <li>1. Scrub function</li> <li>2. No function</li> <li>3. Squeegee function</li> <li>4. Increase brush pressure</li> <li>5. No function</li> <li>6. Decrease brush pressure</li> </ol>	Adjust pressure levels for the three down pressure settings. The level of current flowing to the valve is represented by a bar graph on the display. The neutral head lift feature is disabled in the Pressure adjust mode.
● RESET SCRUB PRESSURES	Select the Reset function from the maintenance 1 screen	<ol style="list-style-type: none"> <li>1. No function</li> <li>2. Reset down pressures</li> <li>3. Do not reset down pressures, exit</li> <li>4. No function</li> <li>5. No function</li> <li>6. No function</li> </ol>	Return the down pressure settings to the factory defaults.

Continued on next page...

## ELECTRICAL

### FRONT PANEL MAINTENANCE MODES (continued from previous page)

MAINTENANCE MODE	ENTRY SEQUENCE	FUNCTIONS AVAILABLE	DESCRIPTION
• ADJUST TIME MODE	Select Adjust Time from the maintenance 2 screen	1. Increment segment 2. Decrement segment 3. Select 24/12 hour clock 4. Move cursor right 5. Move cursor left 6. No function	Set the on board clock and calendar.
• CHECK MAINTENANCE MODE	Select Check maintenance from the maintenance 2 screen	1. No function 2. No function 3. No function 4. Clear maint. timer 5. No function 6. No function LOGO - select next maint. item	Check various maintenance timers.

**INTERLOCKS:**

The operator can start and stop the various functions of the 8210 using a variety of switch closures and interlocks. What follows are two tables for each of the basic functions. One table lists the action that are required for the basic function to be running. The other table lists the actions that would prevent the operation from running.

*NOTE: If the operator satisfies all of the requirements from the first table, and none of the situations of the second table exist, the operator could expect the function to operate.*

**SCRUB BRUSH OPERATION ENABLED**

<b>Scrub brush operation enabled by:</b>	<b>Indicator</b>
<ul style="list-style-type: none"> <li>● Scrub button</li> </ul>	<ul style="list-style-type: none"> <li>● Scrub icon visible with LED illuminated</li> </ul>
<ul style="list-style-type: none"> <li>● Forward propel</li> </ul>	<ul style="list-style-type: none"> <li>● Forward limit switch engaged</li> </ul>

**SCRUB BRUSH OPERATION INHIBITED**

<b>Scrub brush operation inhibited by:</b>	<b>Indicator</b>
<ul style="list-style-type: none"> <li>● Scrub button</li> </ul>	<ul style="list-style-type: none"> <li>● Scrub icon visible with LED extinguished</li> </ul>
<ul style="list-style-type: none"> <li>● Neutral or Reverse</li> </ul>	<ul style="list-style-type: none"> <li>● Forward limit switch disengaged</li> </ul>
<ul style="list-style-type: none"> <li>● Full recovery tank</li> </ul>	<ul style="list-style-type: none"> <li>● Recovery tank full icon visible</li> </ul>

**SQUEEGEE AND VACUUM FAN OPERATION ENABLED**

<b>Squeegee operation enabled by:</b>	<b>Indicator</b>
<ul style="list-style-type: none"> <li>● Scrub button or Squeegee button</li> </ul>	<ul style="list-style-type: none"> <li>● Squeegee icon visible with LED illuminated</li> </ul>
<ul style="list-style-type: none"> <li>● Forward or Neutral</li> </ul>	<ul style="list-style-type: none"> <li>● Reverse limit switch disengaged</li> </ul>

**SQUEEGEE AND VACUUM FAN OPERATION INHIBITED**

<b>Squeegee operation inhibited by:</b>	<b>Indicator</b>
<ul style="list-style-type: none"> <li>● Scrub button or Squeegee button</li> </ul>	<ul style="list-style-type: none"> <li>● Squeegee icon visible with LED extinguished</li> </ul>
<ul style="list-style-type: none"> <li>● Reverse</li> </ul>	<ul style="list-style-type: none"> <li>● Reverse limit switch engaged</li> </ul>
<ul style="list-style-type: none"> <li>● Full recovery tank</li> </ul>	<ul style="list-style-type: none"> <li>● Recovery Tank full icon visible</li> </ul>

## ELECTRICAL

### ES™ PUMP OPERATION ENABLED

ES™ pump operation enabled by:	Indicator
<ul style="list-style-type: none"><li>• ES™ button</li></ul>	<ul style="list-style-type: none"><li>• ES™ icon visible with LED illuminated</li></ul>
<ul style="list-style-type: none"><li>• ES™ float covered, or ES™ 30 second timer running. The ES™ 30 second timer starts when the ES™ pump brings the solution level below the ES™ float</li></ul>	<ul style="list-style-type: none"><li>• None</li></ul>

### ES™ PUMP OPERATION INHIBITED

ES™ pump operation inhibited by:	Indicator
<ul style="list-style-type: none"><li>• ES™ button</li></ul>	<ul style="list-style-type: none"><li>• ES™ icon visible with LED extinguished</li></ul>
<ul style="list-style-type: none"><li>• More than 30 seconds has passed since the ES™ float has become uncovered</li></ul>	<ul style="list-style-type: none"><li>• None</li></ul>
<ul style="list-style-type: none"><li>• Solution Tank Full float covered for more than 5 seconds</li></ul>	<ul style="list-style-type: none"><li>• None</li></ul>

### SWEEP BRUSH OPERATION ENABLED

Sweep brush operation enabled by:	Indicator
<ul style="list-style-type: none"><li>• Sweep button</li></ul>	<ul style="list-style-type: none"><li>• Sweep icon visible and LED illuminated</li></ul>

### SWEEP BRUSH OPERATION INHIBITED

Sweep brush operation inhibited by:	Indicator
<ul style="list-style-type: none"><li>• Sweep button</li></ul>	<ul style="list-style-type: none"><li>• Sweep icon visible and LED extinguished</li></ul>
<ul style="list-style-type: none"><li>• Hopper down switch</li></ul>	<ul style="list-style-type: none"><li>• Hopper up, hopper up icon visible</li></ul>

### SWEEP FAN OPERATION ENABLED

Sweep fan operation enabled by:	Indicator
<ul style="list-style-type: none"><li>• Sweep button</li></ul>	<ul style="list-style-type: none"><li>• Sweep icon visible and LED illuminated</li></ul>
<ul style="list-style-type: none"><li>• Fan button</li></ul>	<ul style="list-style-type: none"><li>• Fan icon visible and LED illuminated</li></ul>

### SWEEP FAN OPERATION INHIBITED

Sweep fan operation inhibited by:	Indicator
<ul style="list-style-type: none"><li>• Fan button</li></ul>	<ul style="list-style-type: none"><li>• Fan icon visible and LED extinguished</li></ul>
<ul style="list-style-type: none"><li>• Hopper down switch</li></ul>	<ul style="list-style-type: none"><li>• Hopper up, hopper up icon visible</li></ul>
<ul style="list-style-type: none"><li>• Hopper Thermal Switch</li></ul>	<ul style="list-style-type: none"><li>• Hopper temperature light</li></ul>
<ul style="list-style-type: none"><li>• Shaker operation</li></ul>	<ul style="list-style-type: none"><li>• Shaker icon with LED light</li></ul>

## SIDE BRUSH OPERATION ENABLED

Side brush operation enabled by:	Indicator
<ul style="list-style-type: none"> <li>Side Brush button</li> </ul>	<ul style="list-style-type: none"> <li>Side brush icon visible and LED illuminated</li> </ul>
<ul style="list-style-type: none"> <li>Sweep button</li> </ul>	<ul style="list-style-type: none"> <li>Sweep icon visible and LED illuminated</li> </ul>

## SIDE BRUSH OPERATION INHIBITED

Side brush operation inhibited by:	Indicator
<ul style="list-style-type: none"> <li>Sweep button</li> </ul>	<ul style="list-style-type: none"> <li>Sweep icon visible and LED extinguished</li> </ul>
<ul style="list-style-type: none"> <li>Side brush button</li> </ul>	<ul style="list-style-type: none"> <li>Side brush icon visible and LED extinguished</li> </ul>
<ul style="list-style-type: none"> <li>Hopper down switch</li> </ul>	<ul style="list-style-type: none"> <li>Hopper up, Hopper up icon visible</li> </ul>
<ul style="list-style-type: none"> <li>Hopper Thermal Sentry™</li> </ul>	<ul style="list-style-type: none"> <li>Hopper temperature light</li> </ul>

## ES™ AIR FLUSH OPERATION ENABLED

The ES™ Airflush valve output has dual functions. This output runs both the ES™ Airflush valve, and the Solution tank autofill. This output will be active if the Airflush conditions are true and the engine is running, or if the autofill conditions are true, and the engine is off.

ES™ Air flush valve enabled by:	Indicator
<ul style="list-style-type: none"> <li>ES™ button and Squeegee button</li> </ul>	<ul style="list-style-type: none"> <li>ES™ and squeegee icons visible and LED's illuminated</li> </ul>
<ul style="list-style-type: none"> <li>ES™ Air flush valve will open for a 5 second period, at a 45 second interval if both ES™ and squeegee are enabled</li> </ul>	<ul style="list-style-type: none"> <li>None</li> </ul>
<ul style="list-style-type: none"> <li>Engine is running</li> </ul>	<ul style="list-style-type: none"> <li>Oil pressure light is off</li> </ul>

## ES™ AIR FLUSH OPERATION INHIBITED

ES™ Air flush valve inhibited by:	Indicator
<ul style="list-style-type: none"> <li>ES™ button, squeegee button</li> </ul>	<ul style="list-style-type: none"> <li>ES™ or squeegee LED is off</li> </ul>
<ul style="list-style-type: none"> <li>Engine is off</li> </ul>	<ul style="list-style-type: none"> <li>Oil pressure light is on</li> </ul>

## SOLUTION TANK AUTOFILL VALVE ENABLED

Solution tank autofill valve enabled by:	Indicator
<ul style="list-style-type: none"> <li>Solution tank full float in down position</li> </ul>	<ul style="list-style-type: none"> <li>None</li> </ul>
<ul style="list-style-type: none"> <li>Machine in neutral</li> </ul>	<ul style="list-style-type: none"> <li>None</li> </ul>
<ul style="list-style-type: none"> <li>Engine is off</li> </ul>	<ul style="list-style-type: none"> <li>Engine oil pressure light is on</li> </ul>

## ELECTRICAL

### SOLUTION TANK AUTOFILL VALVE DISABLED

<b>Solution tank autofill valve disabled by:</b>	<b>Indicator</b>
<ul style="list-style-type: none"><li>● Solution tank full float in up position</li></ul>	<ul style="list-style-type: none"><li>● None</li></ul>
<ul style="list-style-type: none"><li>● Machine in forward or reverse</li></ul>	<ul style="list-style-type: none"><li>● Forward or reverse switches engaged</li></ul>
<ul style="list-style-type: none"><li>● Engine on and hopper door timer (about 3 sec) expired</li></ul>	<ul style="list-style-type: none"><li>● Engine oil pressure light is off</li></ul>

### RECOVERY TANK AUTOFILL VALVE ENABLED

The Recovery tank autofill valve output provides dual functions. This output controls both the Recovery tank autofill valve (engine not running) and the hopper door blocking valve (engine running). To aid starting, this output will be off for 30 seconds after the key is turned on.

<b>Recovery tank autofill valve enabled by:</b>	<b>Indicator</b>
<ul style="list-style-type: none"><li>● Solution tank full float in down position</li></ul>	<ul style="list-style-type: none"><li>● None</li></ul>
<ul style="list-style-type: none"><li>● Machine in neutral</li></ul>	<ul style="list-style-type: none"><li>● None</li></ul>
<ul style="list-style-type: none"><li>● Engine off for more than 30 seconds</li></ul>	<ul style="list-style-type: none"><li>● Oil pressure light on for more than 30 seconds</li></ul>
<ul style="list-style-type: none"><li>● Engine on</li></ul>	<ul style="list-style-type: none"><li>● Oil pressure light off</li></ul>

### RECOVERY TANK AUTOFILL VALVE DISABLED

<b>Recovery tank autofill valve disabled by:</b>	<b>Indicator</b>
<ul style="list-style-type: none"><li>● Solution tank full float in up position</li></ul>	<ul style="list-style-type: none"><li>● None</li></ul>
<ul style="list-style-type: none"><li>● Machine in forward or reverse</li></ul>	<ul style="list-style-type: none"><li>● Forward or reverse switches engaged</li></ul>
<ul style="list-style-type: none"><li>● Engine on</li></ul>	<ul style="list-style-type: none"><li>● Oil pressure light off</li></ul>
<ul style="list-style-type: none"><li>● Engine off for less than 30 seconds</li></ul>	<ul style="list-style-type: none"><li>● Oil pressure light on for less than 30 seconds</li></ul>

### HOPPER DOOR BLOCKING VALVE ENABLED

<b>Hopper door blocking valve enabled by:</b>	<b>Indicator</b>
<ul style="list-style-type: none"><li>● Hopper door active (from the time the hopper door begins moving, until about 3 sec. after movement has started)</li></ul>	<ul style="list-style-type: none"><li>● Hopper door icon visible</li></ul>

### HOPPER DOOR BLOCKING VALVE DISABLED

<b>Hopper door blocking valve disabled by:</b>	<b>Indicator</b>
<ul style="list-style-type: none"><li>● More than 3 seconds passing since the last hopper door move</li></ul>	<ul style="list-style-type: none"><li>● None</li></ul>
<ul style="list-style-type: none"><li>● Sweep or scrub fan running</li></ul>	<ul style="list-style-type: none"><li>● Sweep fan or squeegee LED on</li></ul>



## DETERGENT PUMP ENABLED

Detergent pump enabled by:	Indicator
<ul style="list-style-type: none"> <li>● Scrub button</li> </ul>	<ul style="list-style-type: none"> <li>● Scrub icon active on screen</li> </ul>
<ul style="list-style-type: none"> <li>● Detergent button</li> </ul>	<ul style="list-style-type: none"> <li>● 1 or 2 arrows present on detergent icon</li> </ul>
<ul style="list-style-type: none"> <li>● Forward propel</li> </ul>	<ul style="list-style-type: none"> <li>● Forward limit switch closed</li> </ul>
<ul style="list-style-type: none"> <li>● High or Low water flow</li> </ul>	<ul style="list-style-type: none"> <li>● Voltage sensed on solution flow input</li> </ul>

## DETERGENT PUMP DISABLED

Detergent pump disabled by:	Indicator
<ul style="list-style-type: none"> <li>● Scrub button</li> </ul>	<ul style="list-style-type: none"> <li>● Scrub icon inactive on screen</li> </ul>
<ul style="list-style-type: none"> <li>● Detergent button</li> </ul>	<ul style="list-style-type: none"> <li>● X present below detergent icon</li> </ul>
<ul style="list-style-type: none"> <li>● Neutral</li> </ul>	<ul style="list-style-type: none"> <li>● Forward and reverse limit switches open</li> </ul>
<ul style="list-style-type: none"> <li>● Water flow off</li> </ul>	<ul style="list-style-type: none"> <li>● No voltage sensed on solution flow input</li> </ul>

**BASIC 8210 OPERATION**

○ Each time the panel is turned on, and the engine oil pressure is sensed, the following actions will occur:

1. The main brushes will rotate momentarily, and raise.
2. The hopper door will close.
3. The scrub vacuum fan will run momentarily, and the squeegee will raise.

- **EDGE SCRUB (SCRUB, SWEEP/SCRUB MODE):**

○ Pressing the Edge scrub button will toggle the Edge scrub LED.

If the machine is propelling forward in the scrub mode and the Edge scrub LED is on, the scrub head will shift into the edge scrub position. If the Edge scrub LED is off, the scrub head will return to the retracted position.

- **SQUEEGEE (SCRUB, SWEEP/SCRUB, SWEEP MODE):**

○ If the squeegee LED is off, pressing the squeegee button will drop the squeegee and turn on the vacuum fan. If the squeegee LED is on, pressing the squeegee button will raise the squeegee, initiate a delay, and turn off the vacuum fan. Squeegee operation is inhibited in reverse.

- ENGINE SPEED (ALL MODELS):
  - If the machine is currently in the idle or sweep modes, pressing the scrub button will initiate the following action:
    1. The engine speed is set high.
    2. If the machine is propelling forward, the main brushes will turn on and go down. The down pressure setting will be the same used during the last scrub cycle. The solution will flow at the high, low, or zero rate according to the water position switch.
    3. If the machine is in reverse, the brushes will stay up and off.
    4. If the machine goes into neutral, the brushes will stay on for a short delay, then shut off and retract.
    5. If the Edge scrub LED is on and the machine is propelling forward, the scrub head will go into the edge scrub position.
    6. The scrub vacuum fan will turn on.
    7. If the machine is not in reverse, the squeegee will go down.
    8. If the machine is in reverse, the squeegee will stay up until reverse is no longer sensed.
    9. If the detergent LED is illuminated, the machine is in forward, and the solution flow valve is turned on, the detergent pump will run. The detergent pump will run at its slow rate if one arrow is present on the Detergent icon. The detergent pump will run at its fast rate if two arrows are present on the Detergent icon.
  - If the operator pushes and holds the scrub button, the pressure settings will begin to scroll. The pressure setting displayed after releasing the scrub button will become the new default down pressure setting.

If the scrub function was active and the operator pushes, then releases the scrub button, the following actions will take place:

1. The main brushes will turn off and rise.
2. The edge scrub will turn off and retract.



Continued on next page...

Continued from previous page...

3. The solution flow will turn off.
4. The detergent pump will turn off.
5. A seven second delay will pass, and then the squeegee will rise.
6. A four second delay will pass and the vacuum fan will turn off.

- **DETERGENT (SCRUB MODE):**

- Pressing the detergent button will toggle the function on and off. Holding the detergent button will cause the display to scroll through its two speeds. The detergent pump will run only if the main scrub brushes are active, the machine is propelling forward, and the solution switch is on.

1. OFF (No arrows present on detergent icon)  
 **Detergent pump off**
2. LOW (One arrow present on detergent icon)  
 **Detergent pump low**
3. HIGH (Two arrows present on detergent icon)  
 **Detergent pump high**

- **ES™ (SCRUB MODE):**

- Pressing the ES™ button will enable or disable the ES™ function. In order for the ES™ float to become active, it must be consistently in the up position for at least 10 seconds. If the ES™ function is enabled and the ES™ float becomes active, the following actions will occur.

1. The ES™ pump will begin to run.
2. The ES™ pump will continue to run for 40 seconds after the ES™ float becomes uncovered, or until the solution tank full float becomes covered.

- **OVERFLOW (SCRUB MODE, SWEEP/SCRUB MODE):**

- In order for the recovery tank float to become active, it must be consistently in the up position for at least 10 seconds. If the scrub or vacuum fan are active and the tank full float becomes active the overflow icon will appear, the audible alarm will sound for 10 seconds, and the scrub and squeegee functions will be canceled. The overflow icon will not turn off by simply emptying the recovery tank. The scrub or squeegee buttons must be pressed, or the key switch must be cycled.

- MAIN SWEEP BRUSH (SWEEP MODE, SWEEP/SCRUB MODE):

- If the operator presses the sweep button while in the idle or scrub modes, the following actions will take place:

1. The hopper door will open and engine speed will be set to high.
2. The scrub brush will turn on and lower.
3. The sweep fan will start,
4. The side brush will turn on and lower.

- If the operator presses the sweep button while in the Sweep or Sweep/Scrub modes, the following actions will take place:

1. The hopper door will close.
2. The scrub brush will turn off and rise.
3. The sweep fan will stop.
4. The side brush will turn off and rise.

- SIDE SWEEP BRUSH (SWEEP MODE, SWEEP/SCRUB MODE):

- The side brush is automatically engaged each time the sweep system is turned on. The side brush can be disengaged by pressing the side brush button after pressing the sweep button.

- FILTER SHAKER:

- The Filter Shaker button controls the operation of the filter shaker timer system.

 If the Filter Shaker LED is off, pressing the shaker button will initiate a shake sequence. A shake sequence is defined as follows:

1. The Shaker LED will turn on.
2. The sweep fan will turn off.
3. The filter shaker will start.
4. The filter shaker and LED will remain on for approximately 30 seconds.
5. The filter shaker and LED will turn off.
6. If the sweep fan was engaged before the shake cycle, it will turn on.

Continued on next page...

Continued from previous page...

- ☞ If the Filter Shaker LED is on, pressing the shaker button will turn off the Shaker motor and LED.
- ☞ A 30 second shake sequence will also be initiated each time the sweep fan is turned off.
- ☞ A shake sequence will be cancelled if active while the sweep or sweep vacuum fan is turned on.
- ☞ A shake sequence will be cancelled if active, and the engine speed is dropped to idle.

- VACUUM FAN:

- Pressing the sweep vacuum fan button will enable or disable the fan operation while sweeping.
- ☞ The sweep fan will only operate if the sweep function is engaged.
- ☞ Each time the sweep function is engaged, the fan will be enabled.
- ☞ Each time the sweep function is turned off, the fan will be cancelled.
- ☞ The sweep fan will not operate if the hopper is up.

## MAINTENANCE MODES

The 8210 front panel has a total of eight maintenance modes. The operator can access the maintenance modes by turning the machine off, pressing and holding the button inside the Tennant logo, turning the machine on, holding the button for about 15 seconds, and releasing it. At that point, the panel will display the maintenance modes (three at a time). The operator can scroll through the maintenance modes using the logo button.

Operating Modes	Entry Sequence (how to activate)
<b>Manual Mode;</b> <i>Manually operate discrete functions without interlocks.</i> More info pages 5-79 thru 5-81	1. Turn off the machine 2. Press and hold the logo button 3. Turn on the machine 4. Hold the logo button for 15 seconds 5. Release the logo button 6. Select Manual mode
<b>Input Display Mode;</b> <i>Display the state of floats, limit switches, and sensors.</i> More info page 5-82	1. Turn off the machine 2. Press and hold the logo button 3. Turn on the machine 4. Hold the logo button for 15 seconds 5. Release the logo button 6. Press and release the logo button 7. Select Input mode
<b>Self Test Mode;</b> <i>Normal operation.</i> More info page 5-83	1. Turn off the machine 2. Press and hold the logo button 3. Turn on the machine 4. Hold the logo button for 15 seconds 5. Release the logo button 6. Press and release the logo button twice 7. Select Self Test mode
<b>Pressure Adjust Mode;</b> <i>Adjust pressure levels for the scrub brush down pressure settings.</i> More info pages 5-84 and 5-85	1. Turn off the machine 2. Press and hold the logo button 3. Turn on the machine 4. Hold the logo button for 15 seconds 5. Release the logo button 6. Select Pressure Adjust button
<b>Reset Scrub Pressures;</b> <i>Return the down pressure settings to the factory defaults.</i> More info page 5-86	1. Turn off the machine 2. Press and hold the logo button 3. Turn on the machine 4. Hold the logo button for 15 seconds 5. Release the logo button 6. Select the Reset button 7. Select the Yes option
<b>Set Clock Mode;</b> <i>This mode is used to set the internal clock.</i> More info page 5-87	1. Turn off the machine 2. Press and hold the logo button 3. Turn on the machine 4. Hold the logo button for 15 seconds 5. Release the logo button 6. Press and release the logo button 7. Press the Set Clock button

Operating Mode	Entry Sequence (how to activate)
<b>Manual Mode;</b> <i>Manually operate discrete functions without interlocks.</i>	<ol style="list-style-type: none"> <li>1. Turn off the machine</li> <li>2. Press and hold the logo button</li> <li>3. Turn on the machine</li> <li>4. Hold the logo button for 15 seconds</li> <li>5. Release the logo button</li> <li>6. Select Manual mode</li> </ol>

## MANUAL MODE

In this mode, the operator can turn on and off accessories individually and manually. In the manual mode, the operator can turn on accessories without regard to inputs or interlocks. If, for instance, the operator enables the ES™ pump in the manual mode, it will run regardless of whether or not the ES™ float is in the water.

- TO INITIATE:

1. Turn off the machine.
2. Press and hold the logo button.
3. Turn on the machine.
4. Hold the logo button for 15 seconds.
5. Release the logo button.
6. Select Manual mode.

- OPERATION:

- ☞ All of the following operations are accessed by scrolling to the appropriate screen using the logo button.

- ES™ (scrub mode): *Pressing the ES™ button in the manual mode turns on and off the ES™ pump. The air flush valve will turn on and off at 5 second intervals if the oil pressure light is off and the squeegee is on.*
      - EDGE SCRUB BUTTON (scrub mode): *Pressing the Edge Scrub button will extend or retract the scrub head.*

Continued on next page.....

Continued from previous page....

### ■ OPERATION:

- ENGINE BUTTON: *Pressing the Engine button will toggle the engine between high and low speed.*
- SQUEEGEE BUTTON (scrub mode, sweep mode): *Pressing the Squeegee button will turn on the vacuum fan and lower the squeegee. Reverse is ignored.*
- SCRUB BUTTON (idle, scrub, and sweep mode): *Pressing the Scrub button will turn on and lower the main scrub head. Holding the Scrub button while scrub is active will cause the down pressures to scroll. The neutral head lift feature is de-activated in the Manual mode.*
- DETERGENT BUTTON (scrub mode): *Pressing the Detergent button will cause the detergent LED's to scroll. If no LED's are on, the detergent pump will be off. If one LED is illuminated, the detergent pump will run in low speed. If both LED's are on, the detergent pump will run in high speed.*
- SWEEP BUTTON (sweep mode): *Pressing the Sweep button will turn on and lower the sweep brush. The hopper down switch will have no effect on the sweep brush operation.*
- SIDE BRUSH BUTTON (sweep mode): *Pressing the Side brush button will turn on and lower the side brush.*
- VACUUM FAN BUTTON (sweep mode): *Pressing the Vacuum fan button will turn on or off the sweep vacuum fan. The hopper down switch no longer influences the operation of this device.*
- SHAKER BUTTON (sweep mode): *Pressing the Shaker button will turn on or off the filter shaker.*



Operating Mode	Entry Sequence (how to activate)
<b>Input Display Mode;</b> <i>Display the state of floats, limit switches, and sensors.</i>	<ol style="list-style-type: none"> <li>1. Turn off the machine</li> <li>2. Press and hold the logo button</li> <li>3. Turn on the machine</li> <li>4. Hold the logo button for 15 seconds</li> <li>5. Release the logo button</li> <li>6. Press and release the logo button</li> <li>7. Select Input mode</li> </ol>

### INPUT DISPLAY MODE

In this mode, the operator can observe whether or not inputs to the panel are operating as intended. In the Input display mode, the LED's on the instrument panel, and the graphics screen, display the state if each input to the controller board.

- TO INITIATE:

1. Turn off the machine.
2. Press and hold the logo button.
3. Turn on the machine.
4. Hold the logo button for 15 seconds.
5. Release the logo button.
6. Press and release the logo button.
7. Select Input mode.

PANEL LED	INPUT SIGNAL
ES™ ICON AND LED	ES™ FLOAT
OVERFLOW ICON AND LED	FULL RECOVERY TANK
LEFT ARROW	REVERSE LIMIT SWITCH
RIGHT ARROW	FORWARD LIMIT SWITCH
SHAKER LED	PLUGGED DUST FILTER SENSOR
SOLUTION FULL ICON AND LED	SOLUTION FULL FLOAT
HOPPER UP/DOWN ICON	HOPPER DOWN SWITCH
ARROW INSIDE SOLUTION TANK ICON	SOLUTION FLOW INPUT
HOPPER TEMP ICON AND LED	HOPPER THERMAL SENSOR

Operating Mode	Entry Sequence (how to activate)
<b>Self Test Mode;</b> <i>Normal operation.</i>	<ol style="list-style-type: none"><li>1. Turn off the machine</li><li>2. Press and hold the logo button</li><li>3. Turn on the machine</li><li>4. Hold the logo button for 15 seconds</li><li>5. Release the logo button</li><li>6. Press and release the logo button twice</li><li>7. Select Self Test mode</li></ol>

## SELF TEST MODE

The purpose of the Self test mode is to verify the operation of each output from the circuit board. When the Self test is running, each output will turn on for a short time and the controller will verify that the corresponding output pin was pulled to battery negative. The controller will also turn off the output, and verify that the pin rises back up to battery positive. If the controller senses that an output does not pull to battery negative when turned on, or stays at battery negative when turned off, the Self test will fail. If the Self test fails, the pin number that corresponds to each output that failed will be printed on the controller display. If all of the outputs pass Self test, the "OK" message will be printed on the display screen.

- TO INITIATE:

1. Turn off the machine.
2. Press and hold the logo button.
3. Turn on the machine.
4. Hold the logo button for 15 seconds.
5. Release the logo button.
6. Press and release the logo button twice.
7. Select Self Test mode.

Operating Modes	Entry Sequence (how to activate)
<b>Pressure Adjust Mode;</b> <i>Adjust pressure levels for the scrub brush down pressure settings.</i>	<ol style="list-style-type: none"> <li>1. Turn off the machine</li> <li>2. Press and hold the logo button</li> <li>3. Turn on the machine</li> <li>4. Hold the logo button for 15 seconds</li> <li>5. Release the logo button</li> <li>6. Select Pressure Adjust button</li> </ol>

## PRESSURE ADJUST MODE

When the machine is in this mode, the operator can adjust the down pressures for the main brush. The operator may make independent adjustments to pressures 1, 2, 3, and 4. The operator can change the pressure settings by pressing and holding the scrub button. After each adjustment, the new pressure setting is stored in non-volatile (retained even after power down) memory.

In the pressure adjust mode, the panel will display a vertical bar graph. The length of this bar graph is a measure of the electrical current being supplied to the scrub brush down pressure valve. The horizontal ticks on this graph correspond roughly to the factory currents for pressures 1 through 4. The neutral headlift feature is disabled in the pressure adjust mode.

- TO INITIATE:

1. Turn off the machine.
2. Press and hold the logo button.
3. Turn on the machine.
4. Hold the logo button for 15 seconds.
5. Release the logo button.
6. Select the pressure adjust button.

Continued on next page.....

Continued from previous page....

■ **SCRUB BUTTON:**

Pressing the Scrub button will start the normal scrub sequence. Pressing and holding the scrub button will increment the pressure setting. The neutral headlift feature is disabled in the pressure adjust mode.

■ **SQUEEGEE BUTTON:**

Pressing the Squeegee button will enable and disable the squeegee operation.

■ **UP ARROW:**

Pressing the Up-arrow button will increase the down pressure if the scrub system is active.

■ **DOWN ARROW:**

Pressing the down arrow button will decrease the down pressure if the scrub system is active.

■ **EXIT:**

Pressing the exit button will bring the controller back to the idle mode.

*NOTE: The vertical bar graph represents the current that is flowing to the down pressure valve. If, while running the scrub system (especially in pressures 2 - 4) the bar graph fails to become active, it is likely that a short or open has occurred on the control valve circuit.*

Operating Mode	Entry Sequence (how to activate)
<b>Reset Scrub Pressures;</b> <i>Return the down pressure settings to the factory defaults.</i>	<ol style="list-style-type: none"><li>1. Turn off the machine</li><li>2. Press and hold the logo button</li><li>3. Turn on the machine</li><li>4. Hold the logo button for 15 seconds</li><li>5. Release the logo button</li><li>6. Select the Reset button</li><li>7. Select the Yes option</li></ol>

### RESET SCRUB PRESSURE

This mode allows the operator to restore the original factory default down pressure settings.

- TO INITIATE:

1. Turn off the machine.
2. Press and hold the logo button.
3. Turn on the machine.
4. Hold the logo button for 15 seconds.
5. Release the logo button.
6. Select the Reset button.
7. Select the yes option.

# ELECTRICAL

Operating Mode	Entry Sequence (how to activate)
<b>Set Clock Mode;</b> <i>This mode is used to set the internal clock.</i>	1. Turn off the machine 2. Press and hold the logo button 3. Turn on the machine 4. Hold the logo button for 15 seconds 5. Release the logo button 6. Press and release the logo button 7. Press the Set Clock button

## SET CLOCK

This mode is used to set the internal clock.

- TO INITIATE:

1. Turn off the machine.
2. Press and hold the logo button.
3. Turn on the machine.
4. Hold the logo button for 15 seconds.
5. Release the logo button.
6. Press and release the logo button.
7. Press the set clock button.

- **In the Set clock mode, the touch panel functions as follows:**

+ BUTTON	INCREMENT UNDERLINED SEGMENT
- BUTTON	DECREMENT UNDERLINED SEGMENT
RIGHT ARROW	SHIFT UNDERLINE TO NEXT SEGMENT ON RIGHT
LEFT ARROW	SHIFT UNDERLINE TO NEXT SEGMENT ON LEFT
12/24	SELECT 12 OR 24 HOUR CLOCK

**CHECK MAINTENANCE MODE:**

The check maintenance mode allows the operator to store and monitor the elapsed time between 6 different required maintenance items. Each maintenance items is represented by an icon with the recommended elapsed time interval (in hours) printed below it. The lower left corner of the screen displays the number of hours that have elapsed since this maintenance timer was last reset. The button at the upper right corner of the screen will reset the hour counter for this maintenance item. The operator can scroll through the various maintenance items by pressing the logo button.

If the operator presses the reset button each time one of these maintenance items is performed, this feature will act as an accurate maintenance log, and the reminder for the machine.

- **If the Enable maintenance button from maintenance screen 3 is activated:**

The operator will get a 10 second alert each time the machine is started, if one or more of the maintenance hour counters goes beyond the recommended interval.

---

## TROUBLESHOOTING-8200/8210

---

The following pages contain electrical flow charts to help troubleshoot the model 8200/8210 electrical systems.



**ENGINE WILL NOT CRANK  
(all engines) (8200/8210)**

First check to make sure that:  
 1. Battery is charged.  
 2. Fuel in the fuel tank.  
 3. Unrestricted air filter.

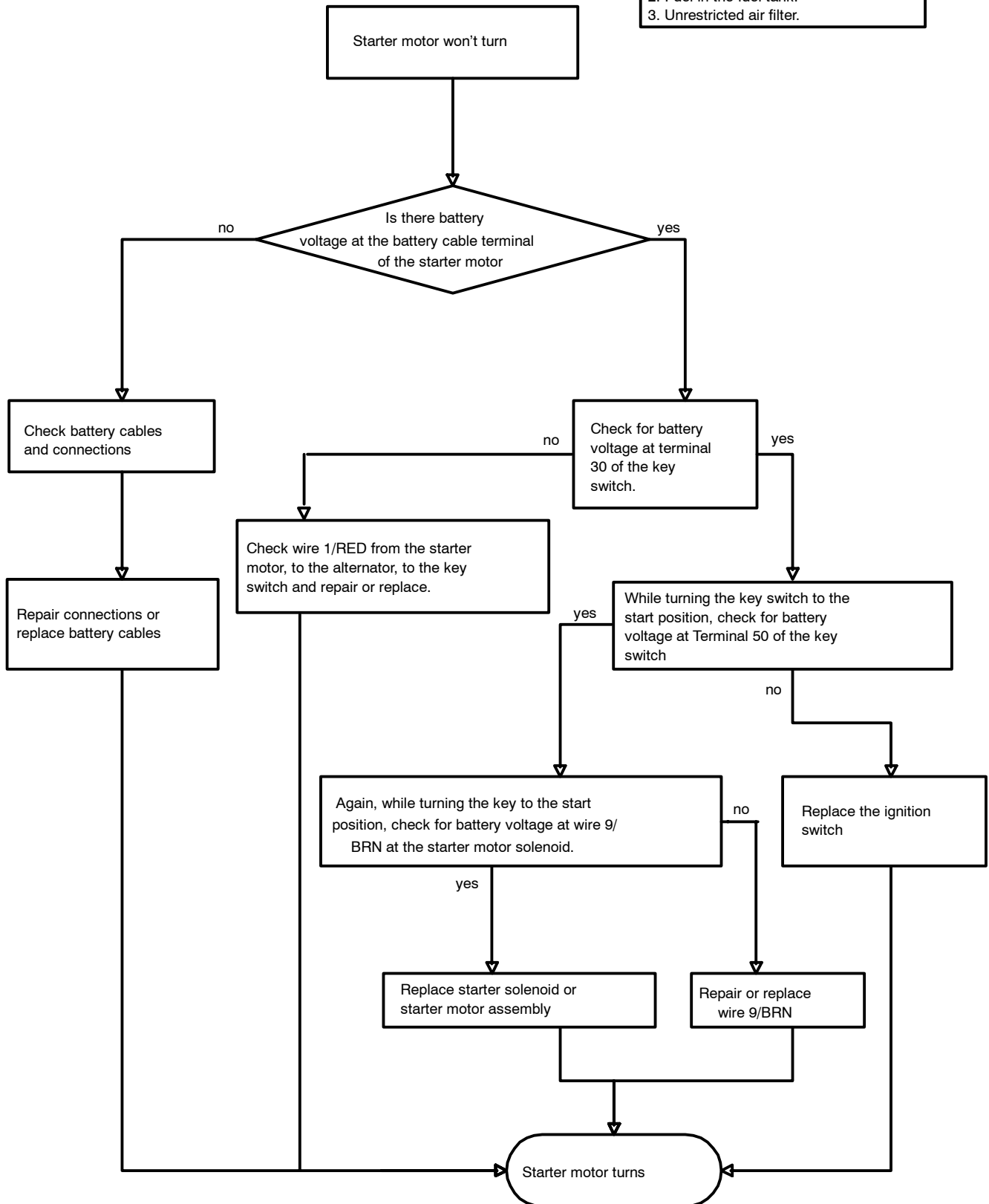

## ENGINE WILL NOT RUN (lpg) (8200/8210)

First check to make sure that:

1. Battery is charged.
2. Fuel in the fuel tank.
3. Unrestricted air filter.
4. Engine oil at full level.

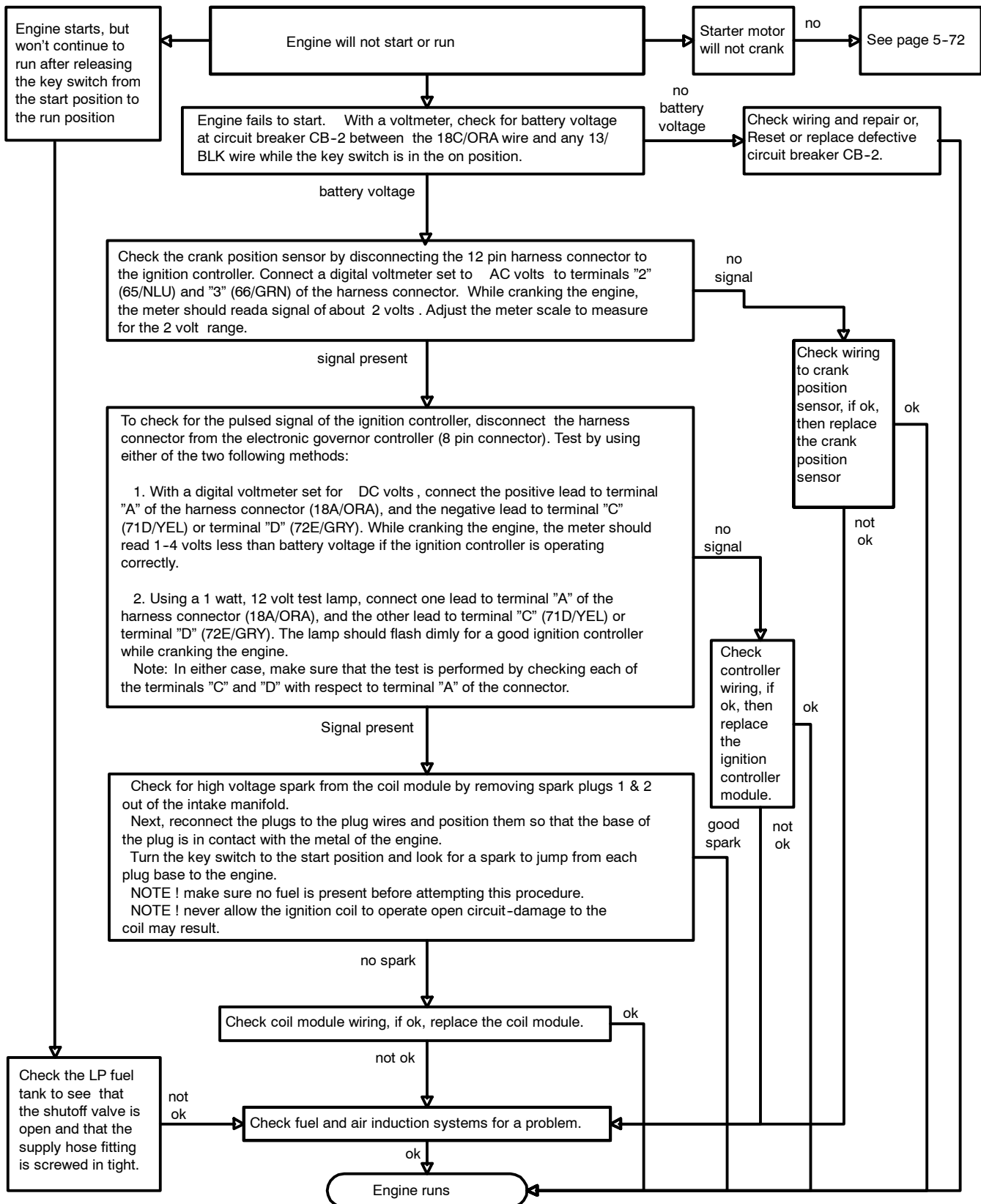

# ENGINE WILL NOT RUN (gas) (8200/8210)

First check to make sure that:  
 1. Battery is charged.  
 2. Fuel in the fuel tank.  
 3. Unrestricted air filter.  
 4. Engine oil at full level.

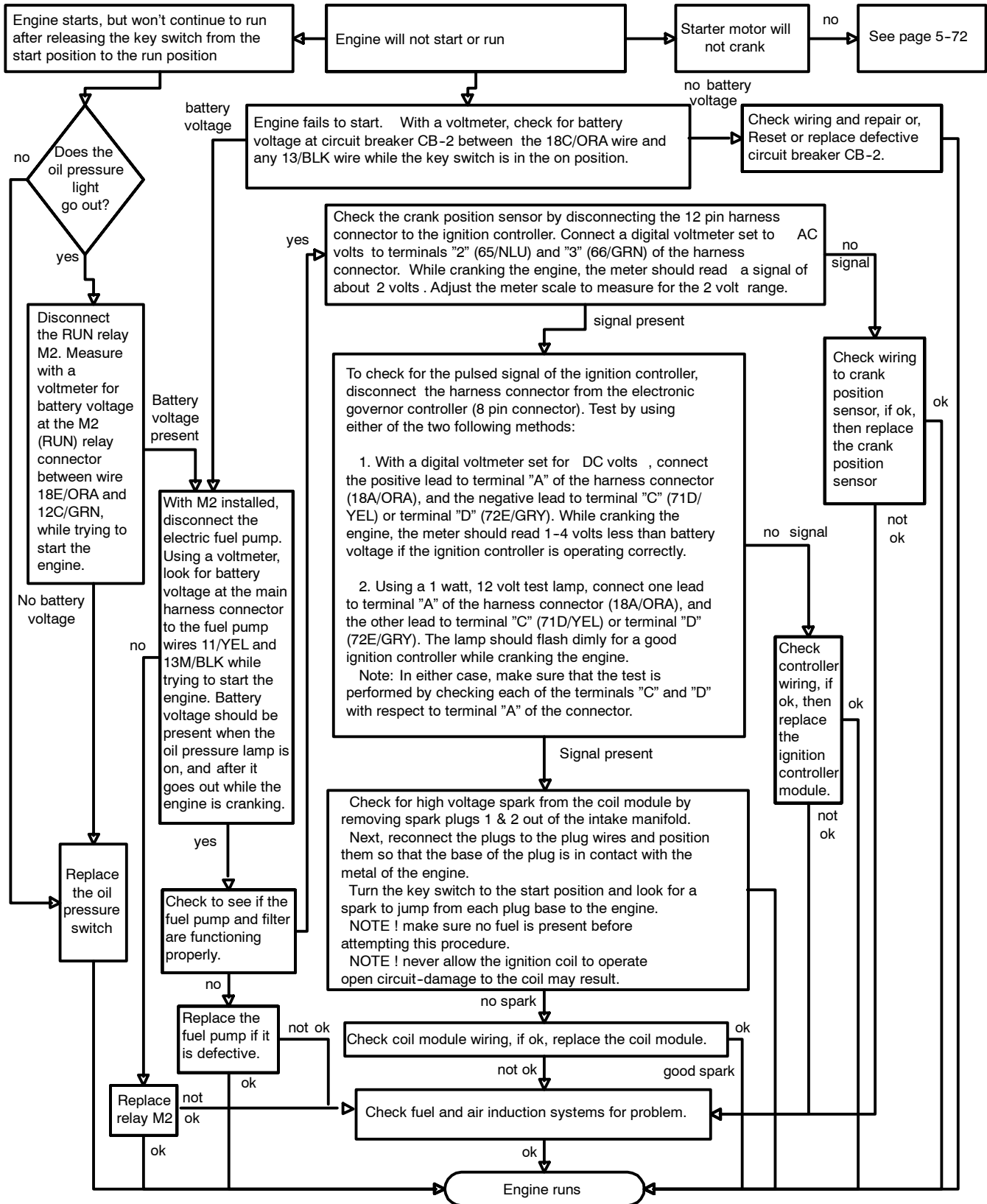

**ENGINE WILL NOT RUN  
(diesel) (8200/8210)**

First check to make sure :  
 1. Battery is charged.  
 2. Fuel in the fuel tank.  
 3. Unrestricted air filter.  
 4. Engine oil at full level.

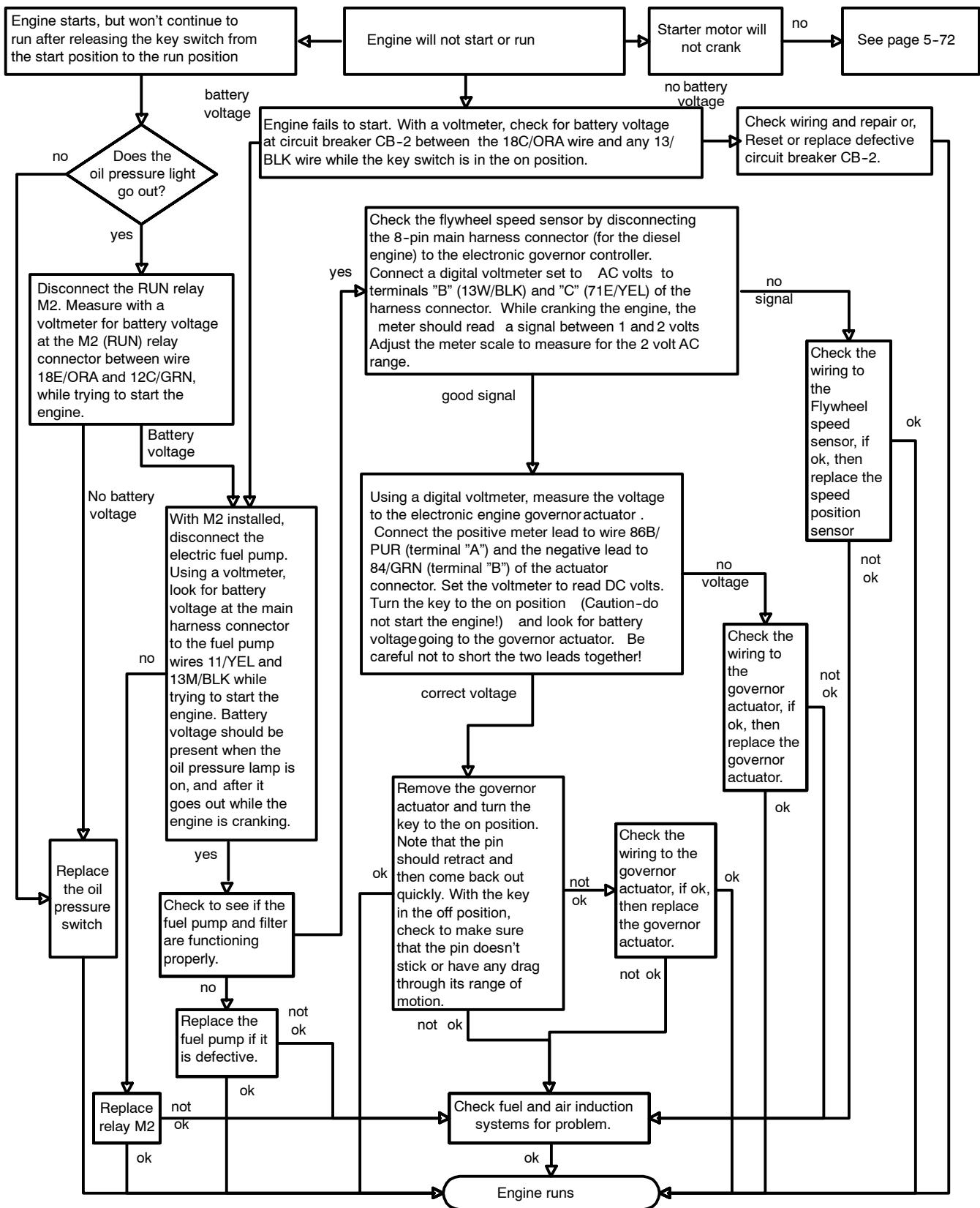

# NO SPEED CHANGE FROM ENGINE GOVERNOR (8200/8210)

First check to make sure that :

1. Battery is fully charged.
2. Electronic engine governor actuator mechanical linkage operates correctly.
3. Electronic Instrument Panel is installed

After the engine is started, it only runs at idle speed and will not run at the correct engine governed speeds when the engine speed select button is selected on the Electronic Instrument Panel. No response from the electronic engine governor actuator .

Checking for battery voltage at the electronic engine governor control.

1. Find and disconnect the 8-pin harness connector to the electronic governor Controller.
2. Connect the positive meter lead of a digital DC voltmeter to the 18/ORN wire (connector terminal "A" ) and the negative lead to the 13/ BLK wire (connector terminal "B" ). Be careful not to short the two leads together!
3. Turn the key to the on position, (Caution-do not start the engine!) and look for battery voltage going to the governor controller.
4. Turn the key switch off.

Does the meter indicate battery voltage to the electronic engine governor controller?

ok

no

yes

Checking the battery voltage supply wiring to the electronic engine governor controller :

1. With an ohmmeter, check the wiring from battery (-) to the 13/BLK wire (connector terminal "B" ) at the wire harness connector to the electronic engine governor controller.
2. With an ohmmeter, check the wiring from 18C/ORN at CB-2 to the 18/ORN wire (connector terminal "A" ) at the wire harness connector to the electronic engine governor controller.

Do the wires check out good?

Repair or replace the defective wiring

yes

Checking for the speed select signal from the electronic instrumrnt panel to the electronic engine governor control.

1. Find and disconnect the 8-pin harness connector to the electronic governor Controller.
2. Connect the positive meter lead of a digital DC voltmeter to the 33/YEL wire (connector terminal "G" ) and the negative lead to the 13/BLK wire. Be careful not to short the two leads together!
3. Turn the key to the on position, (Caution-do not start the engine!) and look for about 10.5 volts going to the governor controller.
4. Press the engine speed select button on the electronic instrument panel and look for the voltage to drop to near zero volts.
5. Turn the key switch off.

Does the meter indicate the correct voltage to the electronic engine governor controller?

ok

no

Checking the engine speed select signal wiring from the electronic instrument panel to the electronic engine governor controller :

1. With an ohmmeter, check the wiring from battery (-) to the 13/BLK wire (connector terminal "B" ) at the wire harness connector to the electronic engine governor controller.
2. With an ohmmeter, check the 33/YEL wire between the harness connector for the electronic instrument panel (connector terminal "R3" ) and the wire harness connector to the electronic engine governor controller (connector terminal "G" ).

Do the wires check out good?

Repair or replace the defective wiring

yes

Checking the engine speed input pulses to the electronic engine governor control .  
See page 5-73 for gas  
See page 5-74 for LPG  
See page 5-75 for diesel

ok

Using a digital voltmeter, measure the voltage to the electronic engine governor actuator . Connect the positive meter lead to wire 86/PUR (connector terminal "A" ) and the negative lead to 84/GRN (connector terminal "B" ) to the governor actuator connector. Set the voltmeter to read DC volts. Turn the key to the on position (Caution-do not start the engine!) and look for battery voltage going to the governor actuator. Be careful not to short the two leads together!

Is a voltage being measured to the governor actuator?

no

yes

Replace the actuator

Checking the wiring from the electronic instrument panel to the electronic engine governor actuator with the key in the off position:

1. With an ohmmeter, check the 86/PUR wire from the electronic engine governor controller (terminal "E" ) to the actuator connector (terminal "A" ) mounted on the engine.
2. With an ohmmeter, check the 84/GRN wire from the electronic engine governor controller (terminal "F" ) to the actuator connector (terminal "B" ) mounted on the engine.

Do the wires check out good?

ok

no

Repair or replace the wiring to the actuator

yes

Engine governor controls speed

## INCORRECT ENGINE GOVERNED SPEED OR RESPONSE (8200/8210)

This troubleshooting guide deals primarily with tuning the governor controller. If the governor actuator is not responding at all, consult page 5-76

First check to make sure :

1. Battery is charged.
2. Engine runs good.

1. For gasoline and LP fueled engines, connect a digital tachometer that measures RPM for distributorless ignition systems.
2. For diesel engines, use an optical tachometer.

See page 5-76

Does the electronic engine governor respond to speed selections from the electronic instrument panel ?

yes

Does the electronic engine governor respond to load and speed selections from the electronic instrument panel in the following manner:

1. The engine speed "hunts" when the engine speed is changed or a load is encountered.
2. The engine responds slowly or sluggishly to speed changes.
3. Inaccurate engine speeds.

If so, proceed further

Theory of operation:

The electronic engine governor for the 8200/8210 application requires a positive voltage (10-12 volts) from the electronic instrument panel to the electronic engine governor connector (terminal "G") in order to enable the low speed of 1350 RPM. If no signal is present at terminal "G", then the governor will cause the engine to operate at the high speed of 2400 RPM.

Voltage status at governor connector terminal "G" :

1. No voltage at terminal "G" indicates a selected high engine speed condition.
2. 9-12volts at "G" indicates a low engine speed condition.

Description of Adjustment Pots:

Type:

- |   |                 |
|---|-----------------|
| 1. P1-high engine speed adjustment.       | 20 turn pot     |
| 2. P2-engine response or gain adjustment. | single turn pot |
| 3. P3-low engine speed adjustment.        | single turn pot |
| 4. P4-medium engine speed adjustment      | single turn pot |
- (Note:P4 is not used on the 8200/8210 product)

Initial Adjustment Settings: CW=Clockwise CCW=Counter clockwise

Adjustments made with the key switch in the off position.

1. Turn P1 20 turns CCW, then 10 turns CW (middle of the adjustment range)
2. Turn P2 full CCW, then 1/4 turn CW.
3. Turn P3 full CCW, then 1/3 turn CW.
4. P4 is not used with this application.

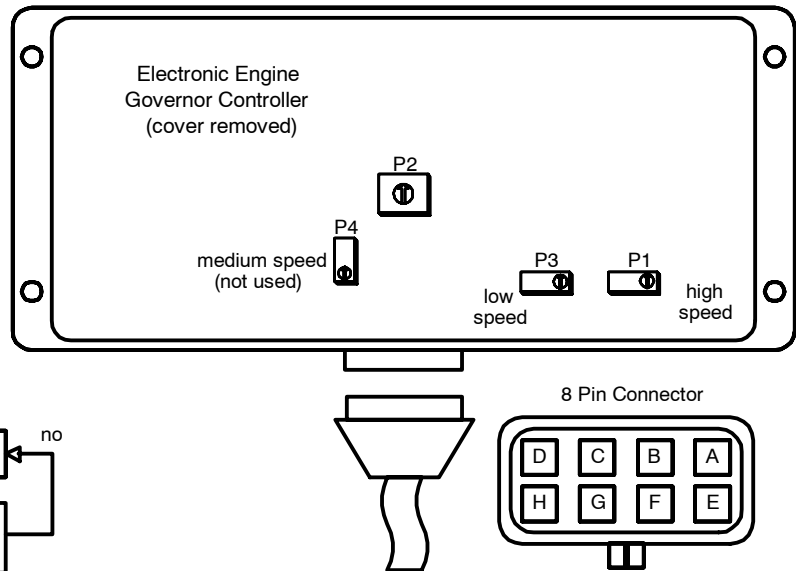

Final Adjustments:

1. Start the engine.
2. P1-using the tachometer, select high speed on the electronic instrument panel and adjust P1 for an engine speed of 2400 RPM.
3. P3-using the tachometer, select low speed on the electronic instrument panel and adjust P3 for an engine speed of 1350 RPM.
4. Check both speeds again and adjust if necessary (Always adjust the high speed first, then the low speed).
5. P2-Adjust for best engine response (make small changes)- Check by pressing the engine speed button from low to high repeatedly. When adjusting P2, sometimes it helps to turn on the machine sweeping function intermittently to test the response of the electronic engine governor

Does the engine governor respond properly?

no

yes

Check the actuator for smooth motion with the following:

1. Disconnect the governor actuator from the main wire harness. (For diesel applications, remove the actuator.)
2. Using a variable DC voltage power supply, connect the supply leads to the governor actuator.
3. Increase the voltage gradually to the actuator until approximately 12 volts is reached.
4. Watch the movement of the armature as the voltage is increased and decreased.

Does the armature of the actuator move smoothly without any sticking motion ?

no

yes

Replace the governor actuator

Replace the governor controller

ok

ok

Correct engine response

# MAIN SWEEPING BRUSH WILL NOT RUN (8200)

First check for the following:  
 1. Correct hydraulic oil level  
 2. Engine is runs properly  
 3. Hopper is fully lowered.

Note: Operation of the main sweep brush is dependent upon the hopper down limit switch, and the main sweep brush limit switch!

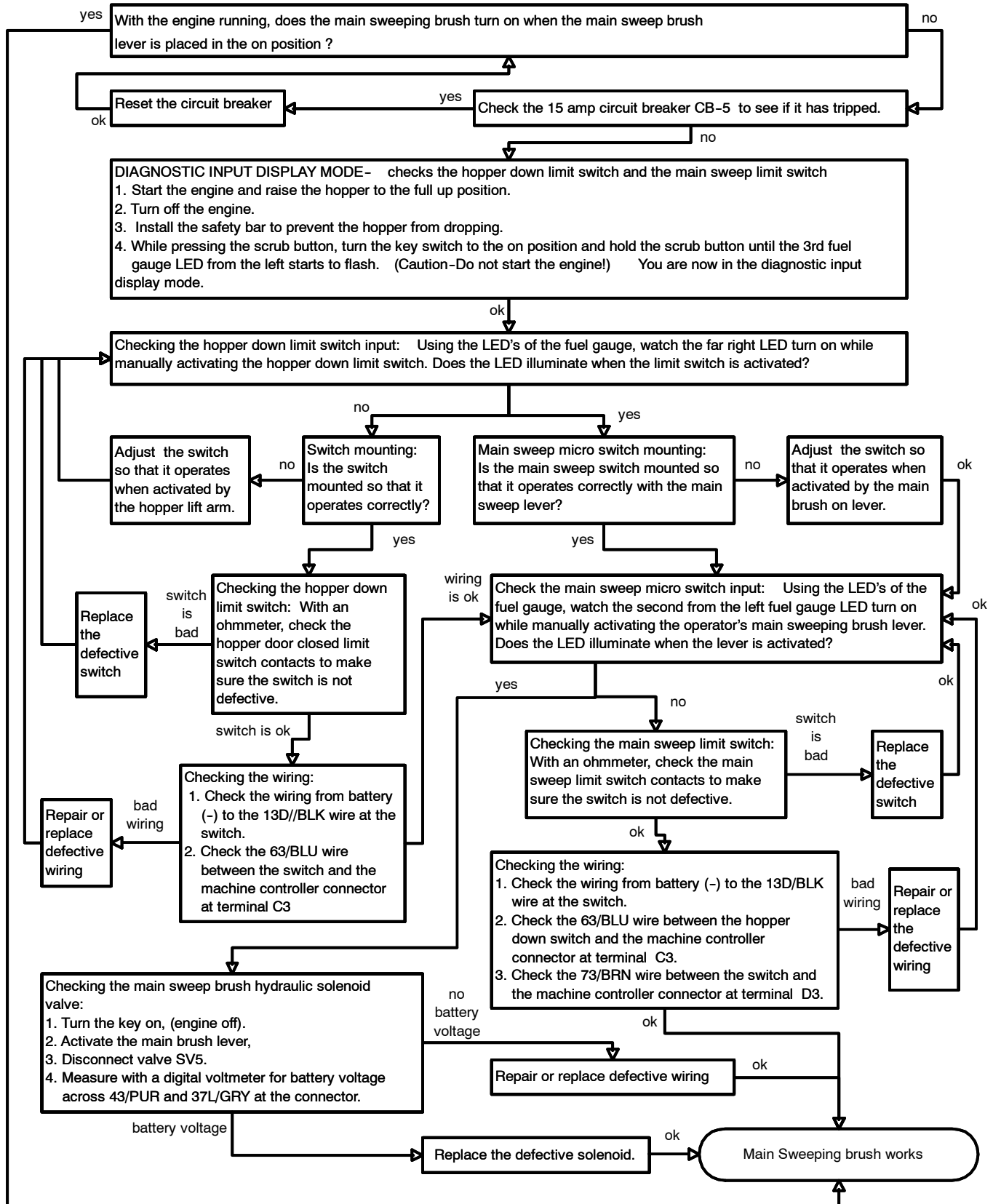

## SIDE BRUSH WILL NOT RUN (8200)

First check for the following:  
 1. Correct hydraulic oil level  
 2. Engine is runs properly  
 3. Hopper is fully lowered  
 4. Main brush page 5-78

Note: Operation of the side sweep brush is dependent upon the hopper down switch, main sweep brush, and the side sweep brush switch.

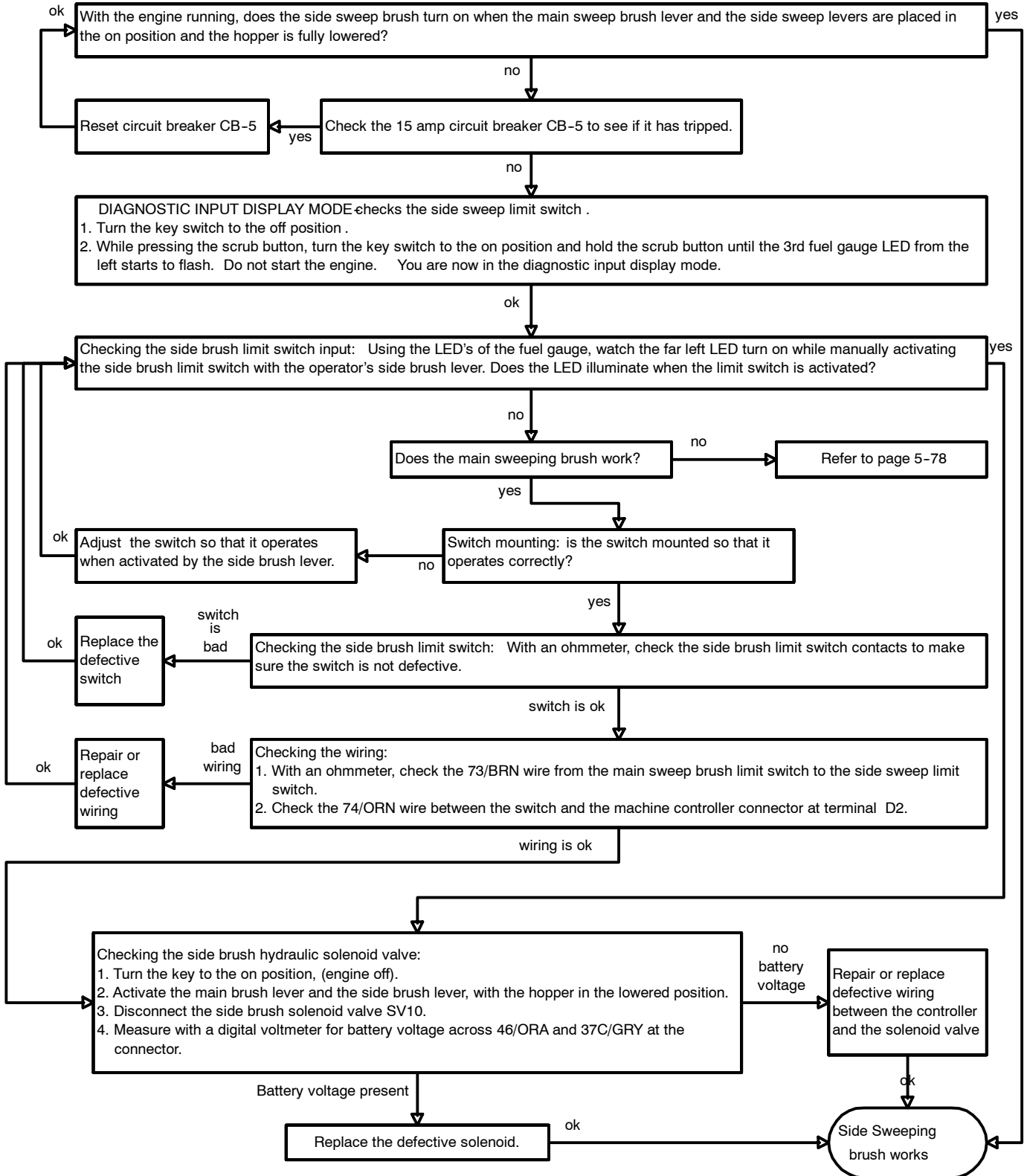



**SWEEPING VACUUM FAN WILL NOT RUN (8200)**

First check for the following:  
 1. Hydraulic system is functioning properly  
 2. Engine is runs properly  
 3. Hopper is fully lowered

Note: Operation of the sweeping vacuum fan is dependent upon the hopper down switch and the hopper thermal sentry switch.

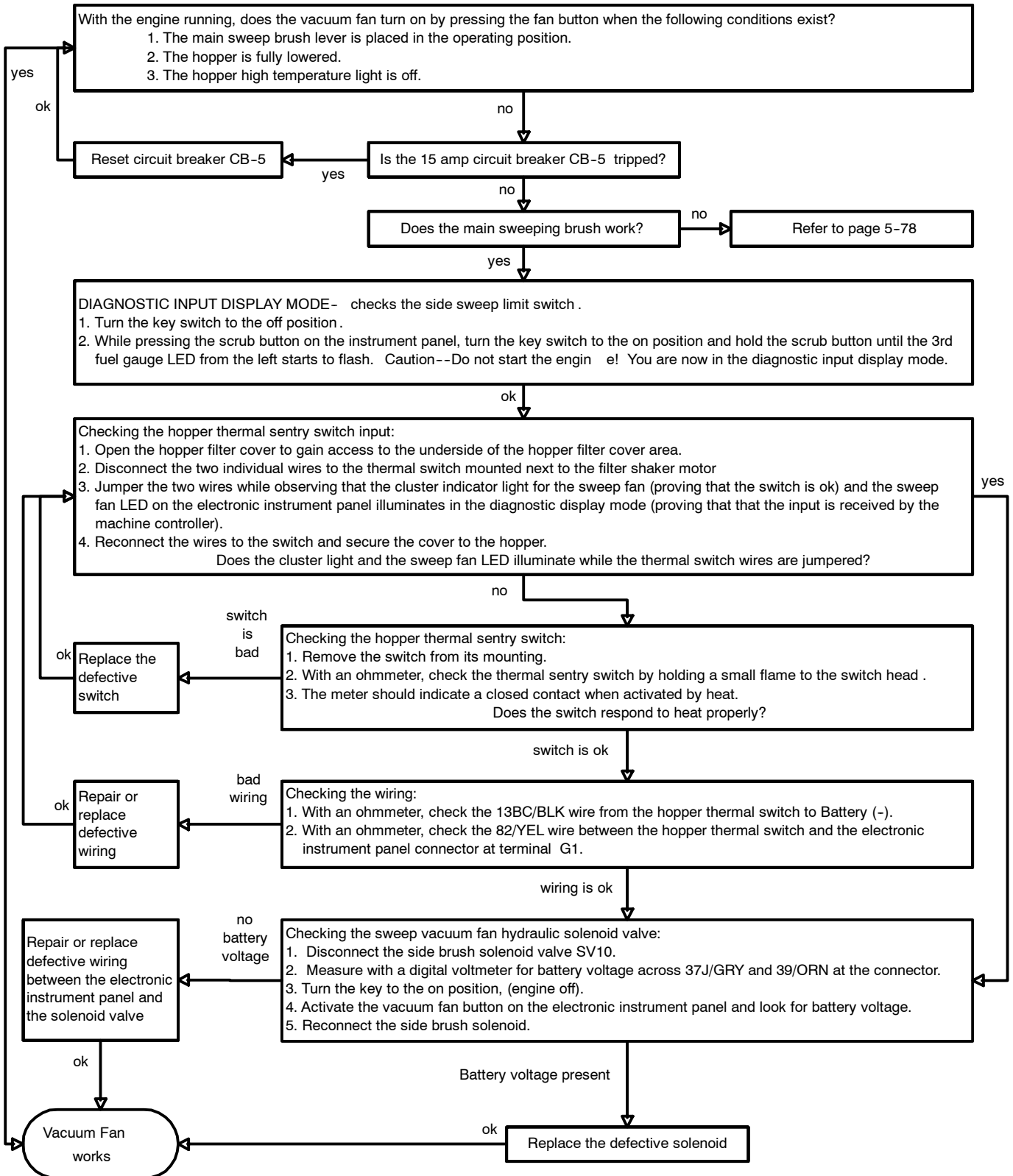

## FILTER SHAKER WILL NOT RUN (8200)

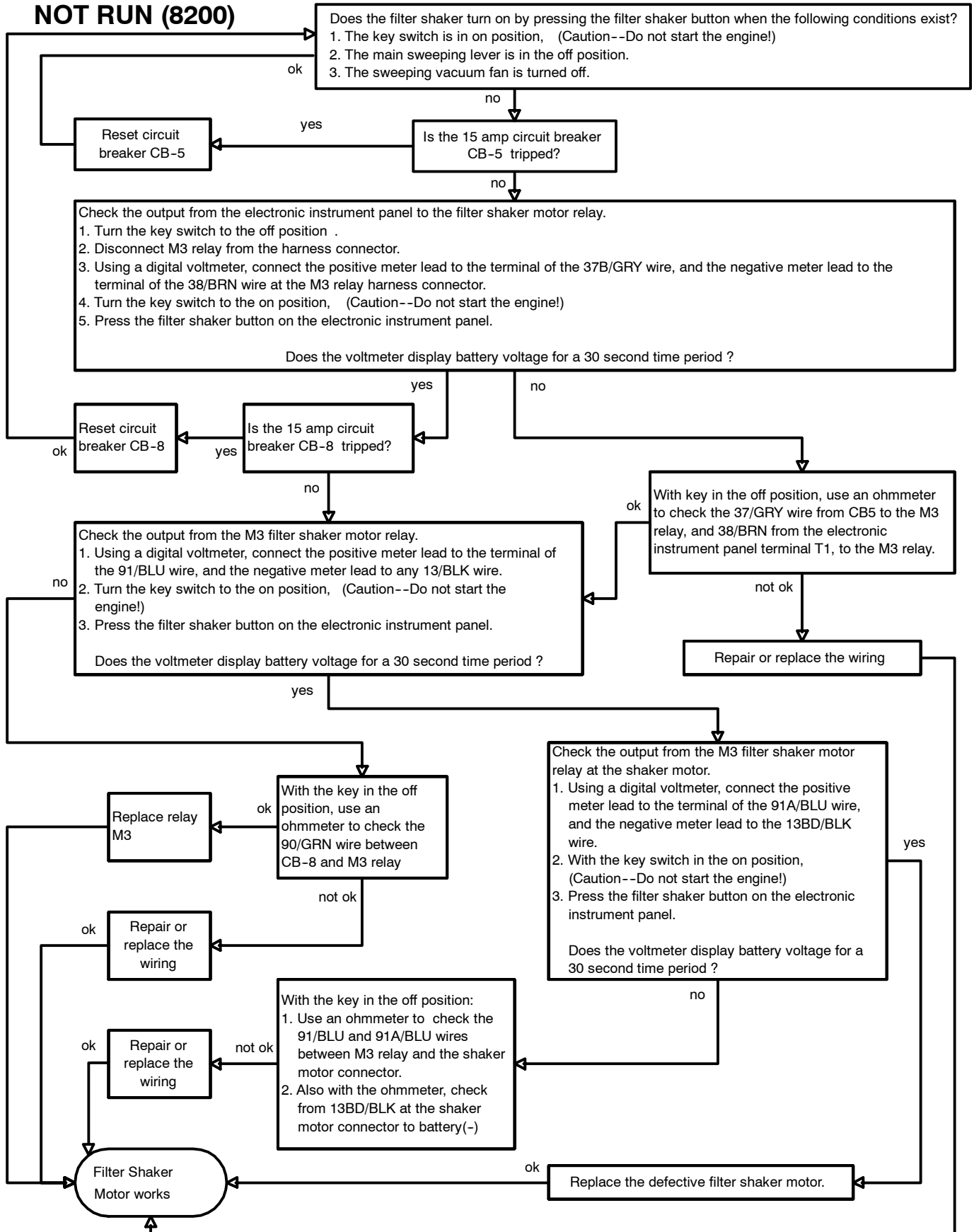

**SCRUB BRUSHES WILL NOT RAISE OR LOWER (8200)**

First check for the following:  
 1. Correct hydraulic oil level  
 2. Propel pedal is enabled  
 3. Recovery tank is not full

Note: Normal operation of the scrub brush lift is dependent upon pressing the scrub brush switch, activating the forward propel pedal limit switch, the recovery tank is not full, and the engine in the high speed mode.

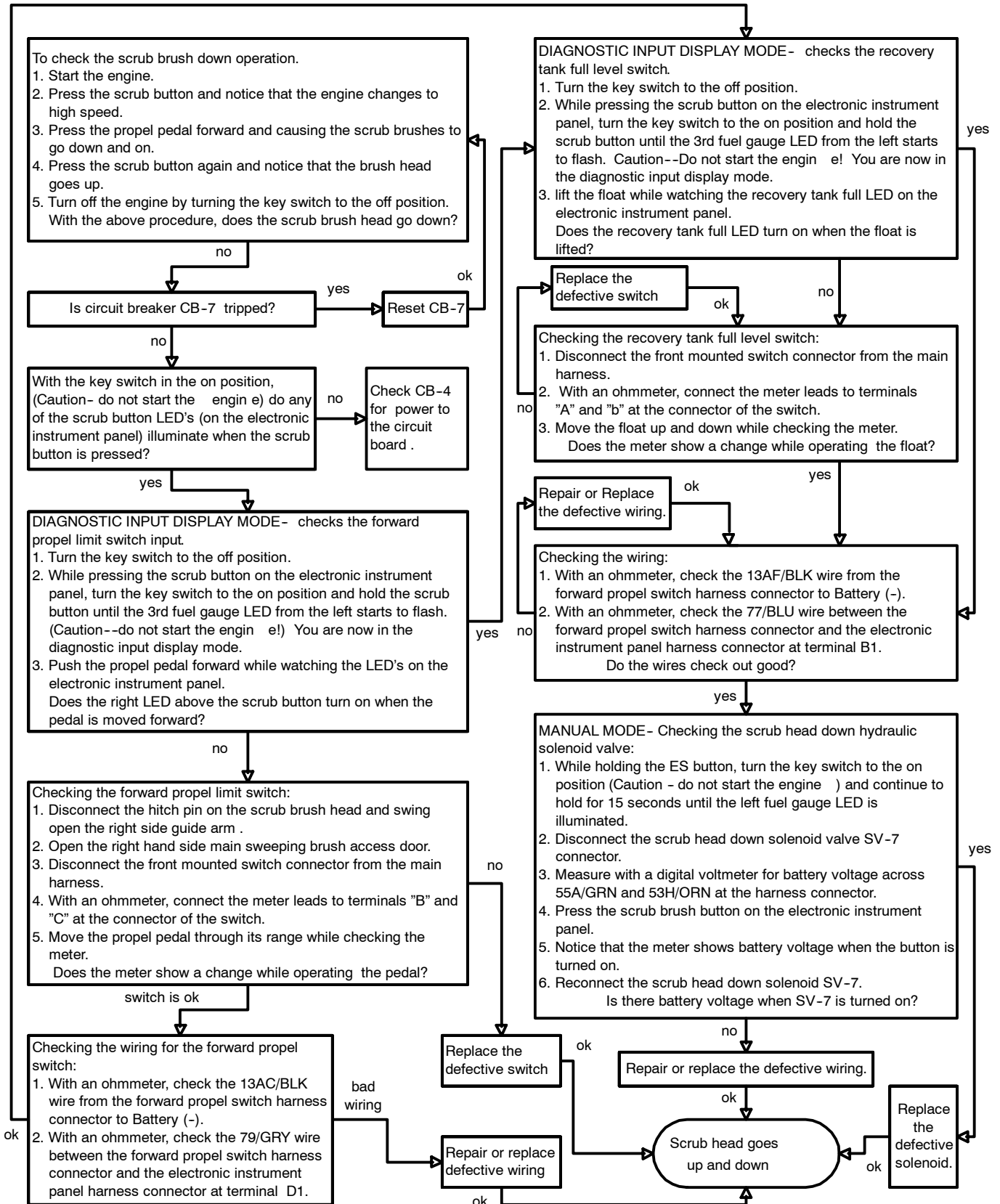

## SCRUB BRUSHES WILL NOT TURN ON (8200)

First check for the following:  
 1. Correct hydraulic oil level  
 2. Propel pedal is enabled  
 3. Recovery tank is not full

Note: Normal operation of the scrub brushes are dependent upon pressing the scrub brush switch, activating the forward propel pedal limit switch, the recovery tank is not full, and the engine in the high speed mode.

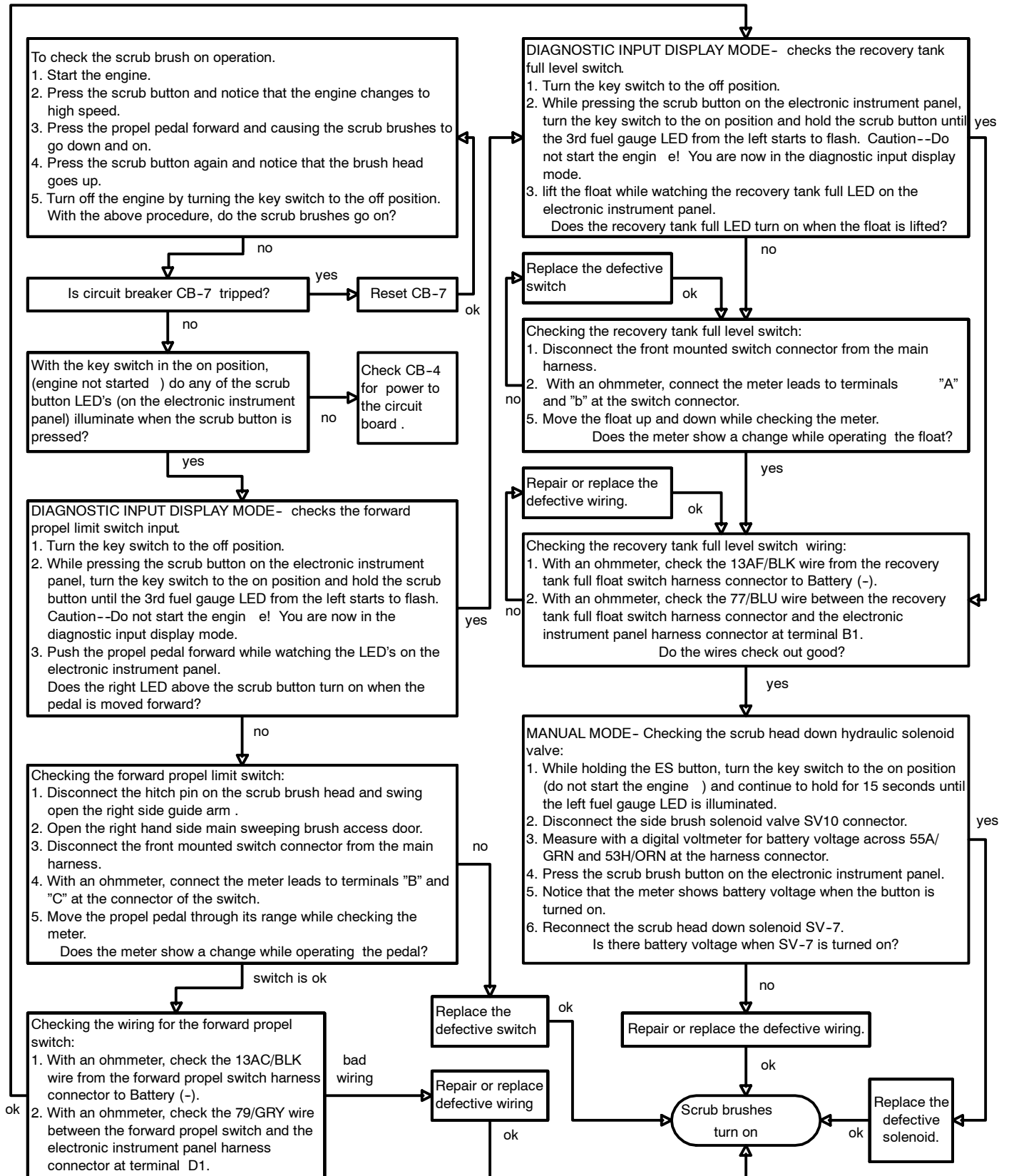

## SCRUB HEAD DOWN FORCE (SV-8) (8200)

First check for the following:

1. Correct hydraulic oil level
2. Propel pedel is enabled
3. Recovery tank is not full

Note: Normal operation to lower the scrub brushes are dependent upon pressing the scrub brush switch, the scrub head down valve SV-7 operation (see sheet 4.A), activating the forward propel pedal limit switch, the recovery tank is not full, and the engine in the high speed mode.

### A. SCRUB BRUSH HEAD DOWN FORCE ELECTRICAL CHECK

Two visual checks are provided to help determine if the scrub brush down force solenoid SV-8 is working correctly.

1. With the key switch in on position (Caution--Do not start the engine!) , the OK light on the indicator light cluster should be on. If the OK light is not on, the electronic instrument panel may be detecting a shorted output.
2. With the key switch in on position (Caution--Do not start the engine!) , press the scrub button on the electronic instrument panel. If none of the LED's for down force selection are illuminated, an open circuit with SV-8 has been detected.

Check for the following conditions:

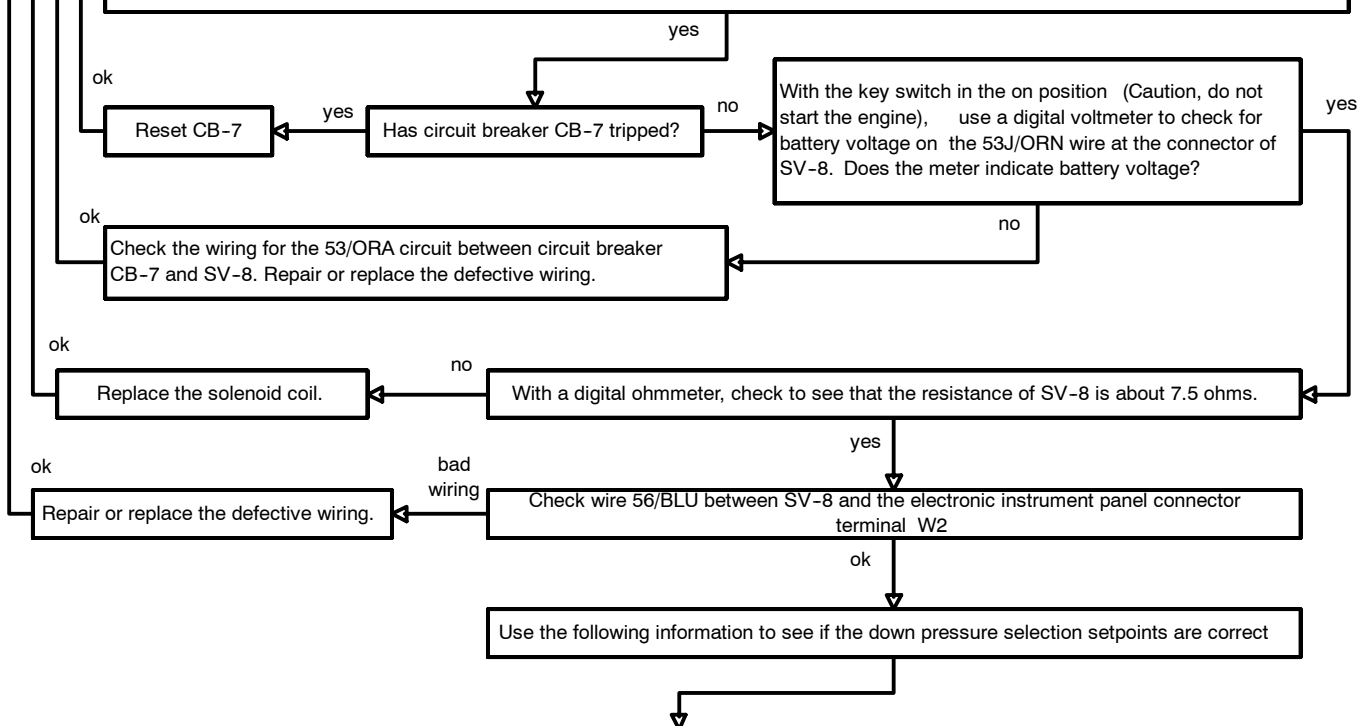

### B. SCRUB PRESSURE SELECTION –allows the adjustment of down force to the scrub brush head .

The scrub brush system is designed to provide a selection of three increments of down force for a variety of cleaning applications. These three selections are represented by displaying one, two, or three LED's above the scrub button. One LED illuminated represents the lowest scrub brush down force applied to the floor, all three LED's illuminated would indicate the heaviest scrub brush down force to the floor. Once the selection is made, it will remain stored until another change is made later. The operator can choose the appropriate selection based on the cleaning requirements.

To change the selection:

1. Turn the key switch to the on position (starting the engine is not necessary).
2. Press the scrub button on the electronic instrument panel to momentarily turn the scrub function on and off.
3. Press and hold the scrub button, to scroll the selection of three available setpoints for brush down force.

### C. FACTORY DEFAULT SETPOINTS

1. The machine is built with three setpoints that should work well for most applications. These setpoints correspond to the amount of DC current supplied to the down force hydraulic solenoid valve (SV-8) during a scrubbing operation.
2. Approximate default scrubbing selection setpoint values in milliamperes (ma).:
  - 1st Scrubbing selection (1 LED) - 20 ma.
  - 2nd Scrubbing selection (2 LED's) - 350 ma.
  - 3rd Scrubbing selection (3 LED's) - 645 ma.

Proceed to the next page

## SCRUB HEAD DOWN FORCE (SV-8) (8200)-continued

D. SCRUB PRESSURE SETPOINT CALIBRATION (USING THE FUEL GAUGE LED'S). -Allows the adjustment of individual setpoints for each of the three down pressure selections.

In special situations, a customized calibration other than the factory default settings, may be used to provide a unique performance characteristic.

To change the setpoint:

1. Turn the key switch to the off position.
2. While pressing the edge scrub button on the instrument panel, turn the key switch to the on position and hold the edge scrub button for 15 seconds until the the edge scrub LED starts to flash (Caution--Do not start the engine!) . You are now in the scrub force adjustment mode.
3. Press and hold the scrub button until the appropriate selection is displayed by the scrolling LED's above the scrub button.
4. To assist with the adjustment, the 4 fuel guage LED's display specific values within the adjustment range (only in the scrub force adjust mode).
  - 1st fuel guage LED turns on at 11ma. of current supplied to SV-8.
  - 2nd fuel guage LED turns on at 350ma. of current supplied to SV-8.
  - 3rd fuel guage LED turns on at 642ma. of current supplied to SV-8.
  - 4th fuel guage LED turns on at 745ma. of current supplied to SV-8.
5. Adjust the setpoint for each selection using the following procedure:
  - a. Enter the scrub brush down force adjust mode using the above procedure.
  - b. Press and hold the scrub button until the appropriate selection is displayed by the scrolling LED's above the scrub button.
  - c. Press and hold the detergent selection button to increase the brush down force selection setpoint . This will increase the DC current to SV-8 for that selection causing more LED's to light if the detergent button is continued to be held.
  - d. Press and hold the squeegee button to decrease the brush down force selection setpoint . This will decrease the DC current to SV-8 for that selection causing less LED's to light if the squeegee button is continued to be held.
  - e. After adjusting each selection for its desired setpoint, press the scrub button to the off state, (scrub force selection LED's turn off) in order to store the new setpoint in to memory. Then press and hold the scrub button to scroll to the next selection.
  - f. When each of the selections have the desired setpoint, turn the key switch off, to leave the scrub force adjustment mode.

Note: Be patient when using the LED's as a reference for down force adjustment, sometimes it takes a long period of time to hold either the detergent button or the squeegee button to affect a change with the fuel guage LED's.

or

E. SCRUB PRESSURE SETPOINT CALIBRATION (USING A DIGITAL MULTIMETER)- Checking the down force output from the electronic instrument pan el to SV-8, and allows a precise adjustment of individual setpoints for each of the three down pressure selections.

1. Instead of using the fuel guage LED's for DC current reference to SV-8, this value can be measured by connecting a digital multimeter in series with one of the wires to the coil of SV-8. Use caution when connecting the meter, and select a range to measure 0-1000 milliamperes.
2. Disconnect the scrub down force solenoid SV-8.
3. Install a jumper between the SV-8 connector and the harness connector for SV-8, that will enable a series connection for measuring the DC current through one of the wires to the SV-8 solenoid coil with a digital multimeter.
4. Enter the scrub force adjustment mode using the procedure outlined above, (steps 1 and 2).
5. Choose the the desired down force selection, (as in step 3 above).
6. While observing the meter, adjust the setpoints to the desired values using the default information in B.2 above as a reference point:
  - a. Press and hold the detergent selection button to increase the brush down force selection setpoint. This will increase the DC current to SV-8 for that selection as indicated on the meter.
  - b. Press and hold the squeegee button to decrease the brush down force selection setpoint. This will decrease the DC current to SV-8 for that selection as indicated on the meter.
  - c. After adjusting each selection for its desired setpoint, press the scrub button to the off state, (scrub force selection LED's turn off) in order to store the new setpoint in to memory. Then press and hold the scrub button to scroll to the next selection.
  - d. When each of the selections have the desired setpoint, turn the key switch off, to leave the scrub force adjustment mode.

**SCRUB HEAD EDGE  
SCRUB WILL NOT  
SHIFT (8200)**

First check for the following:  
 1. Correct hydraulic oil level  
 2. Propel pedal is enabled  
 3. Recovery tank is not full

Note: Normal operation of the scrub brush lift is dependent upon pressing the scrub brush switch, activating the forward propel pedal limit switch, the recovery tank is not full, and the engine in the high speed mode.

To check the scrub brush head edge scrub operation.  
 1. Start the engine.  
 2. Press the scrub button on the electronic instrument panel and notice that the engine changes to high speed.  
 3. Press the propel pedal forward (slightly) (Caution- the machine may move forward) causing the scrub brush head to move down and shift outward.  
 4. Press the edge scrub button again and notice that the brush head moves in.  
 5. Press the scrub button again and notice that the brush head raises and the brushes turn off.  
 6. Turn off the engine by turning the key switch to the off position.  
 With the above procedure, does the scrub brush head move out and in?

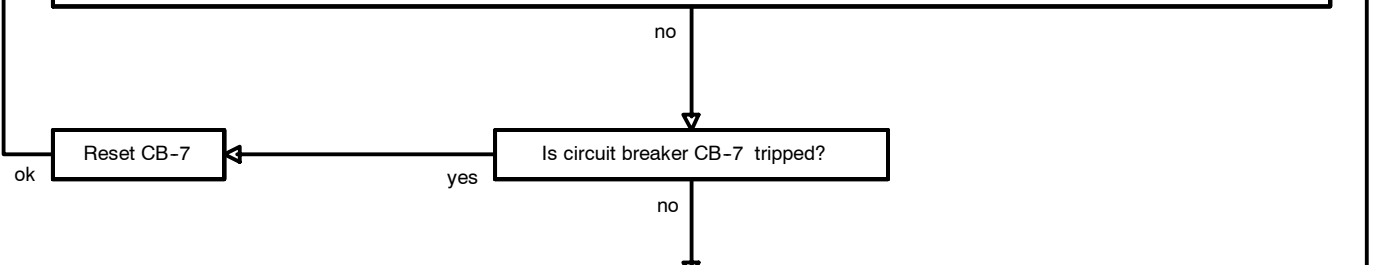

**MANUAL MODE - Checking the output from the electronic instrument panel to the edge scrub hydraulic solenoid valve:**  
 1. While holding the ES button, turn the key switch to the on position ( do not start the engine ) and continue to hold for 15 seconds until the left fuel gauge LED is illuminated.  
 2. Disconnect the edge scrub shift solenoid valve SV13 connector.  
 3. Measure with a digital voltmeter for battery voltage across 57/PUR and 53E/ORN at the harness connector.  
 4. Press the Edge Scrub button on the electronic instrument panel.  
 5. Notice that the meter shows battery voltage when the edge scrub function is enabled.  
 6. Reconnect the Edge Scrub solenoid SV-13 to the wiring harness.  
 Is there battery voltage when SV-13 is turned on?

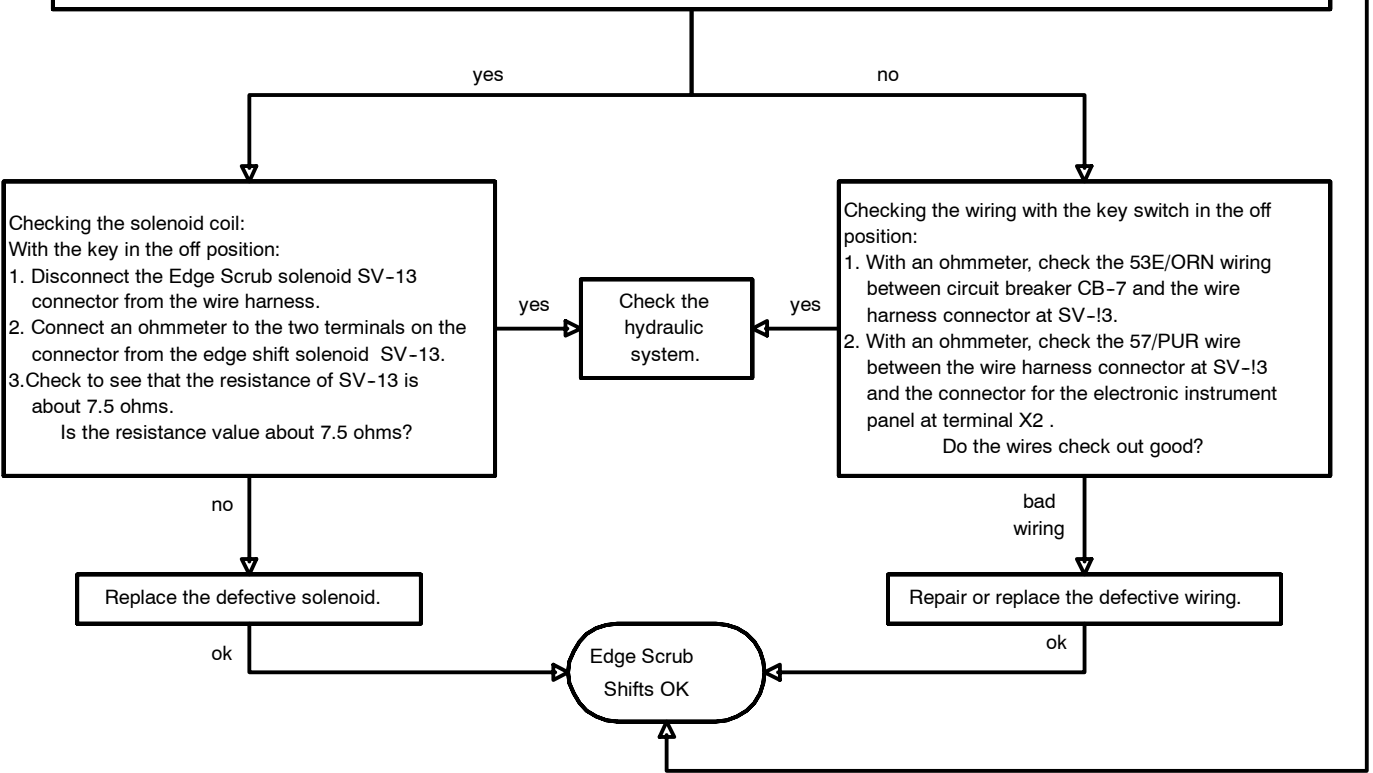

## SQUEEGEE WILL NOT LOWER (8200)

First check for the following:

1. Correct hydraulic oil level
2. Propel pedal is not in reverse
3. Recovery tank is not full

Note: Normal operation of the squeegee lower function is dependent upon pressing the scrub or squeegee button, activating the forward or reverse propel pedal limit switch, the recovery tank is not full, and the engine in the high speed mode.

To check the squeegee lower operation.

1. Start the engine.
  2. Press the squeegee button on the electronic instrument panel and notice that the engine changes to high speed.
  3. The vacuum fan will turn on and the squeegee will move down.
  4. Move the propel pedal slightly to reverse (Caution- the machine may move!) and notice that the squeegee moves up.
  5. Turn off the engine by turning the key switch to the off position.
- With the above procedure, does the scrub brush head move out and in?

ok

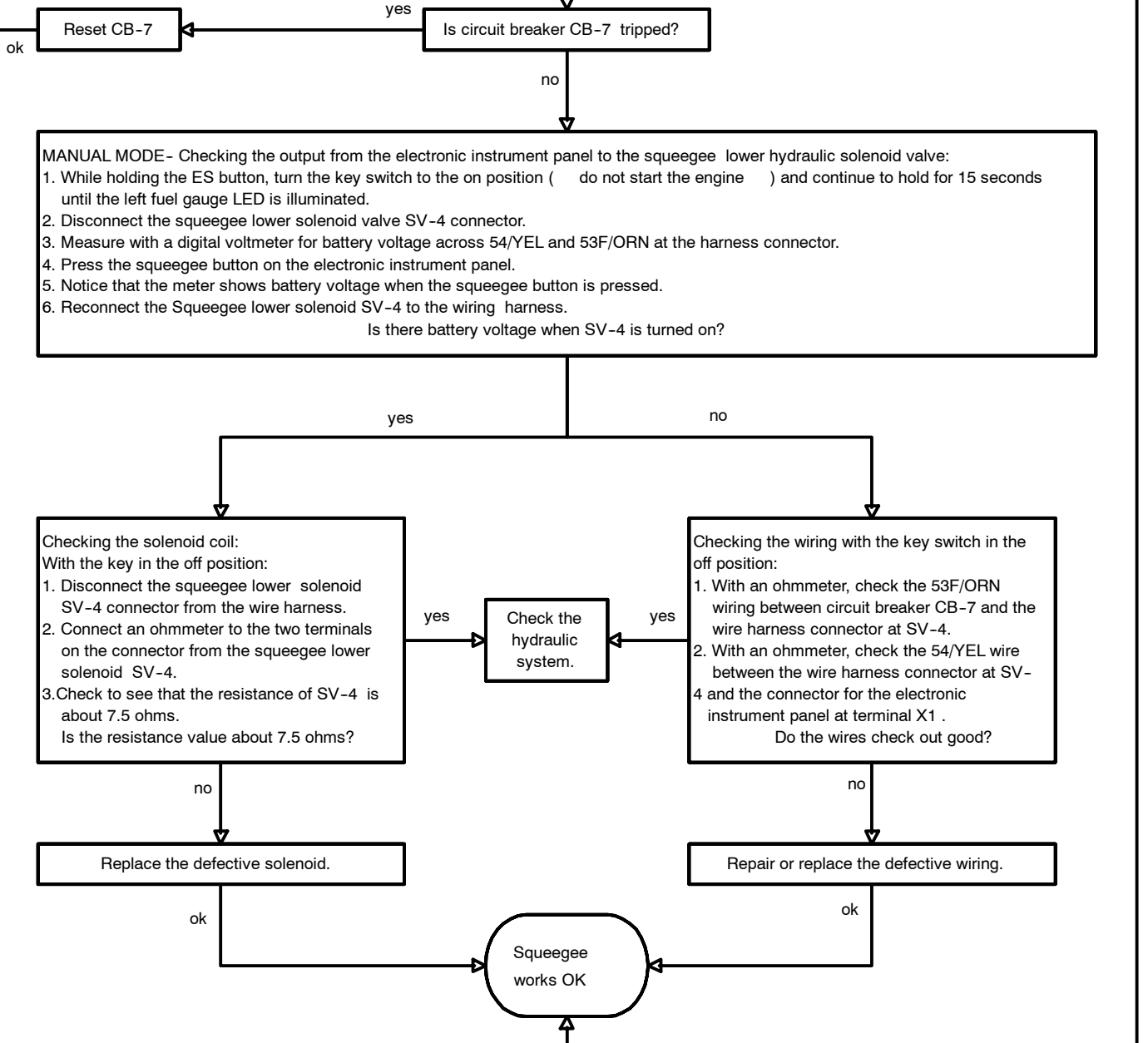



# SCRUB VACUUM FAN WILL NOT RUN (8200)

First check for the following:  
 1. Correct hydraulic oil level  
 2. Recovery tank is not full  
 3. Vacuum lines are not restricted

Note: Normal operation of the scrub vacuum fan function is dependent upon pressing the scrub or squeegee button, activating the forward or reverse propel pedal limit switches, the recovery tank is not full, and the engine in the high speed mode.

To check the scrub vacuum fan operation.  
 1. Start the engine.  
 2. Press the squeegee button on the electronic instrument panel and notice that the engine changes to high speed.  
 3. The vacuum fan will turn on and the squeegee will move down.  
 4. Move the propel pedal slightly to reverse (Caution- the machine may move!) and notice that the squeegee moves up.  
 5. Move the pedal back to neutral and press the squeegee button to raise the squeegee and turn off the vacuum fan after 6 seconds.  
 6. Turn off the engine by turning the key switch to the off position.  
 With the above procedure, does the scrub brush head move out and in?

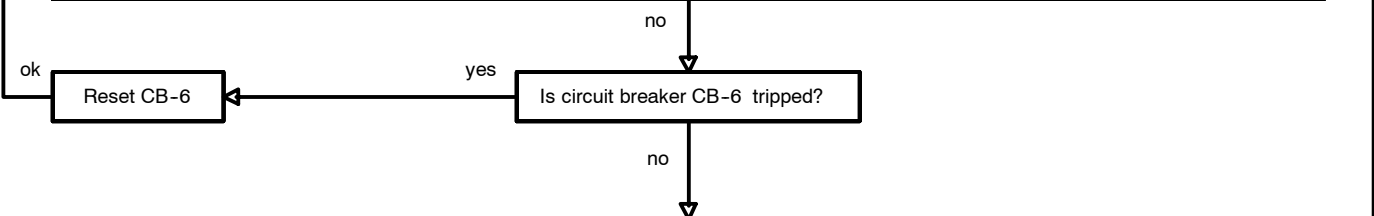

**MANUAL MODE- Checking the output from the electronic instrument panel to the vacuum fan hydraulic solenoid valve:**  
 1. Turn the key switch to the on position (Caution- do not start the engine ).  
 2. Disconnect the scrub vacuum fan solenoid valve SV-1 connector.  
 3. Measure with a digital voltmeter for battery voltage across wires 52/BRN and 47D/YEL at the harness connector for the scrub vacuum fan .  
 4. Press the squeegee button on the electronic instrument panel.  
 5. Notice that the meter shows battery voltage when the squeegee button pressed.  
 6. Reconnect the scrub vacuum fan solenoid SV-1 to the wiring harness.  
 Is there battery voltage when SV-1 is turned on?

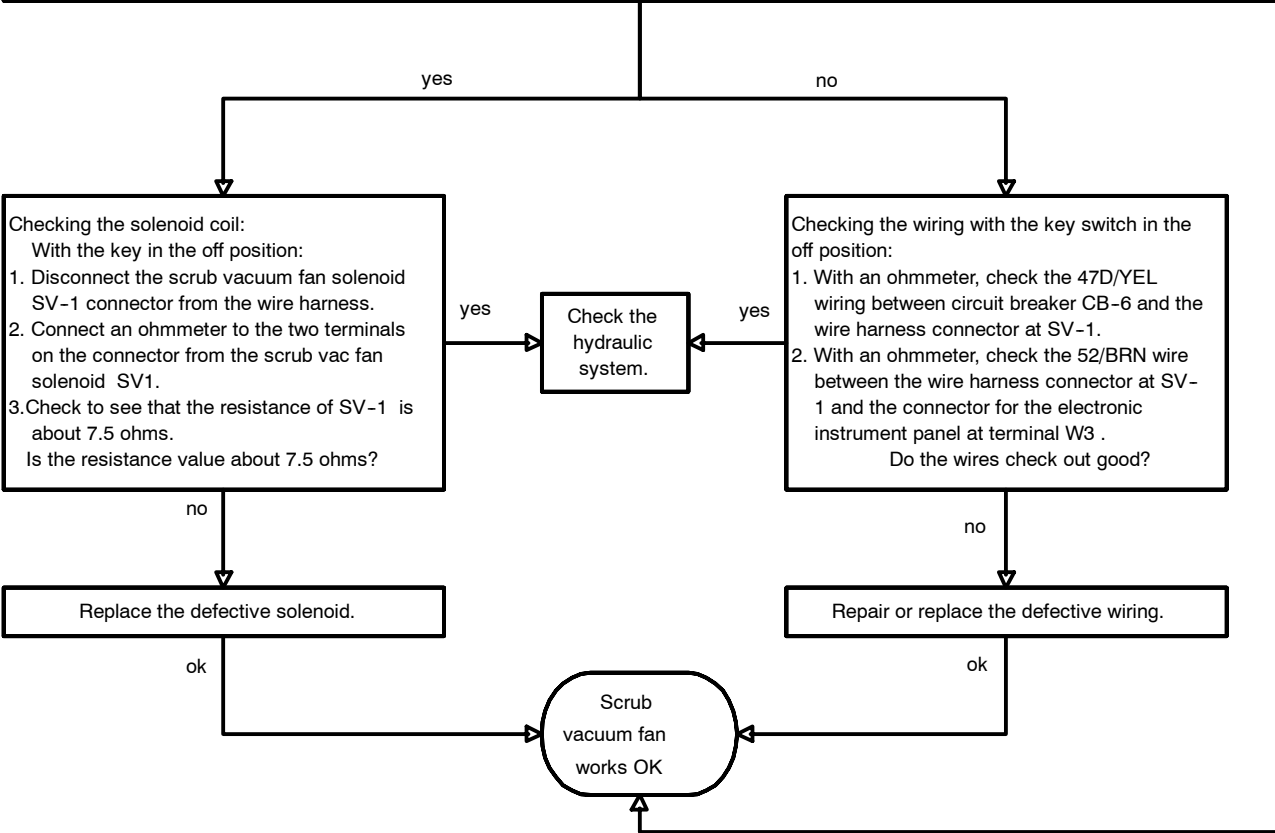

## SOLUTION CONTROL WILL NOT OPERATE (8200)

First check for the following:  
 1. Correct solution tank level  
 2. Recovery tank is not full  
 3. Solution lines are not restricted

Note: Normal operation of the scrub solution control is dependent upon pressing the scrub button, activating the forward or reverse propel pedal limit switches, the recovery tank is not full, and the engine in the high speed mode.

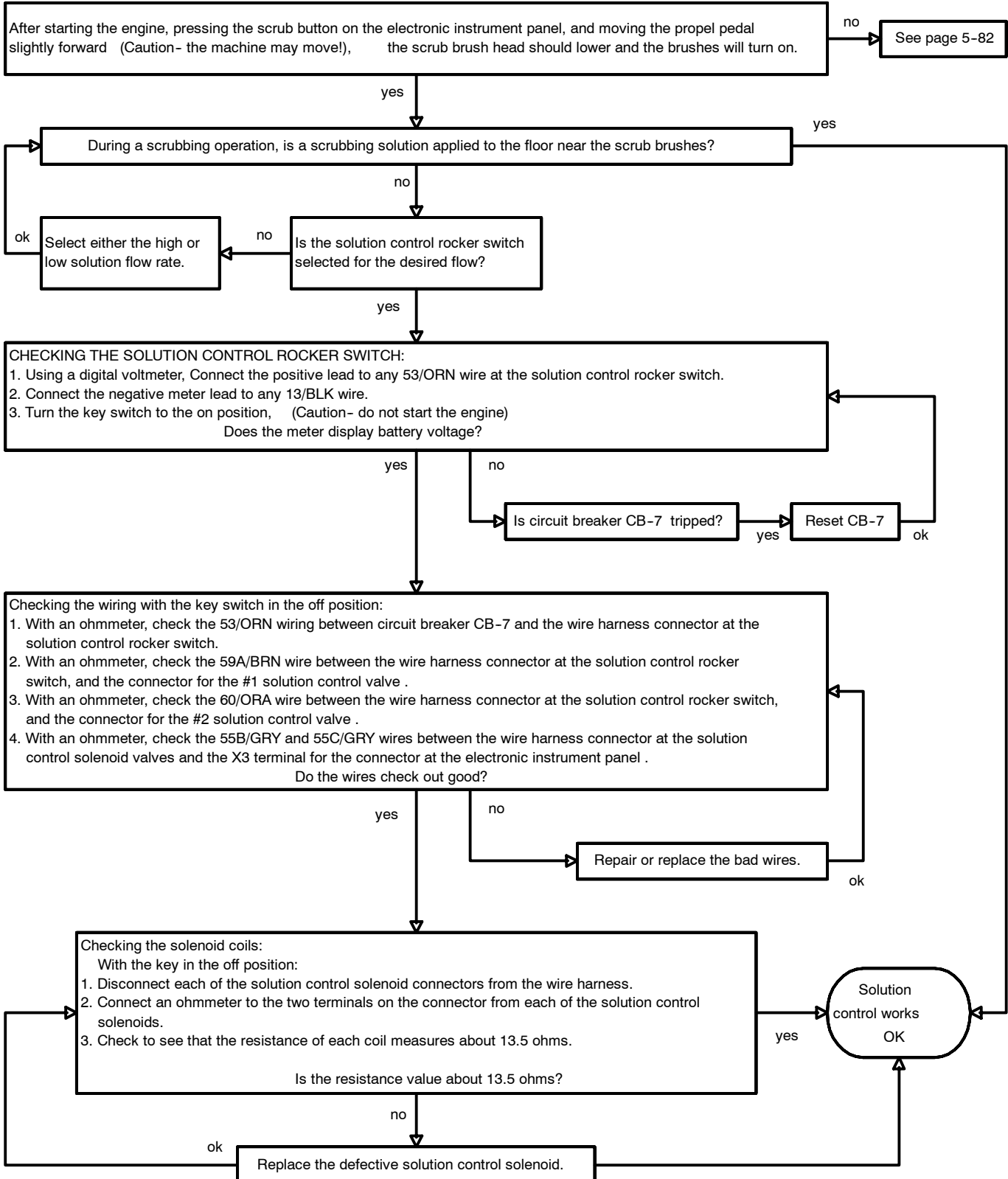

# DETERGENT PUMP WILL NOT OPERATE (8200)

First check for the following:  
 1. Correct detergent tank level  
 2. Recovery tank is not full  
 3. Solution switch is on high or low

Note: Normal operation of the detergent metering pump requires that one of the detergent flow rates is selected on the electronic instrument panel, the solution control rocker switch must be set to high or low, and operating in the scrub mode with the machine propelling forward.

To check the detergent metering pump operation :

1. Disconnect the hitch pin on the scrub brush head and swing open the right side guide arm .
2. Open the right side main sweeping brush access door.
3. Find the detergent metering pump located under the floor, just below the foot pedals
4. Turn the key switch to the on position (Caution-do not start the engine).
5. Press the scrub button on the electronic instrument panel.
6. Select the solution control rocker switch to either high or low flow .
7. Press the detergent metering button on the electronic instrument panel to either high or low flow.
8. Move the propel pedal slightly to the forward direction.
9. Notice if the pump motor is running.
10. Turn off the key switch to the off position.

With the above procedure, does the detergent metering pump operate?

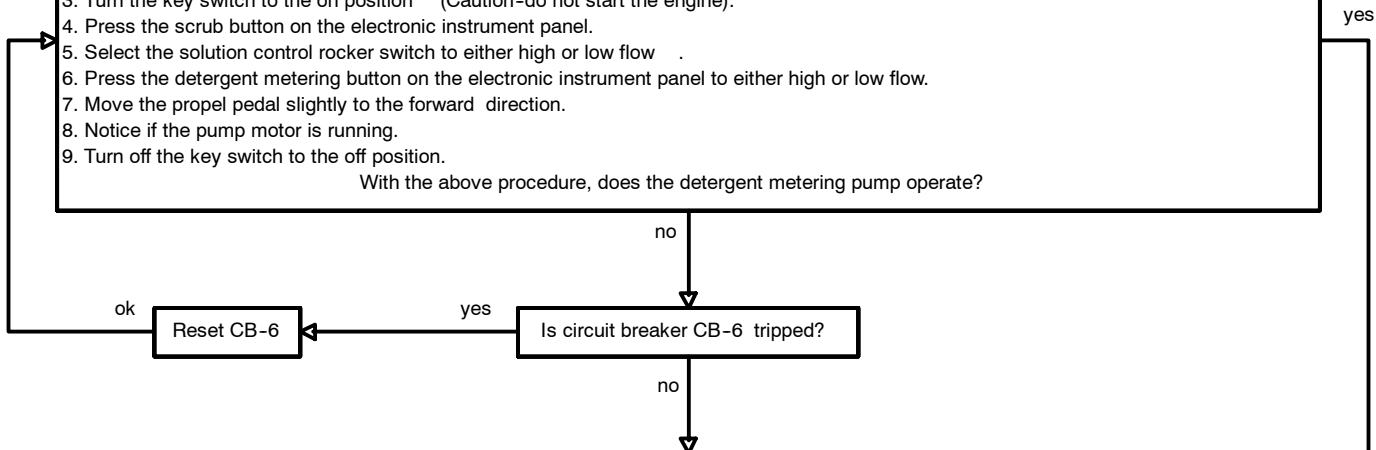

MANUAL MODE- Checking the output from the electronic instrument panel to the edge scrub hydraulic solenoid valve:

1. While holding the ES button, turn the key switch to the on position (Caution, do not start the engine ) and continue to hold for 15 seconds until the left fuel gauge LED is illuminated.
2. Disconnect the detergent metering pump motor connector from the wire harness.
3. Measure with a digital voltmeter for DC voltage across 47K/YEL and 51/GRY at the harness connector to the detergent pump.
4. Press the detergent button on the electronic instrument panel.
5. The meter should indicated almost battery voltage when the high detergent flow rate is selected, and less than half of battery voltage when the low flow rate is selected.
6. Reconnect the detergent metering pump motor connector to the wire harness.

Is there a DC voltage when the detergent pump is turned on?

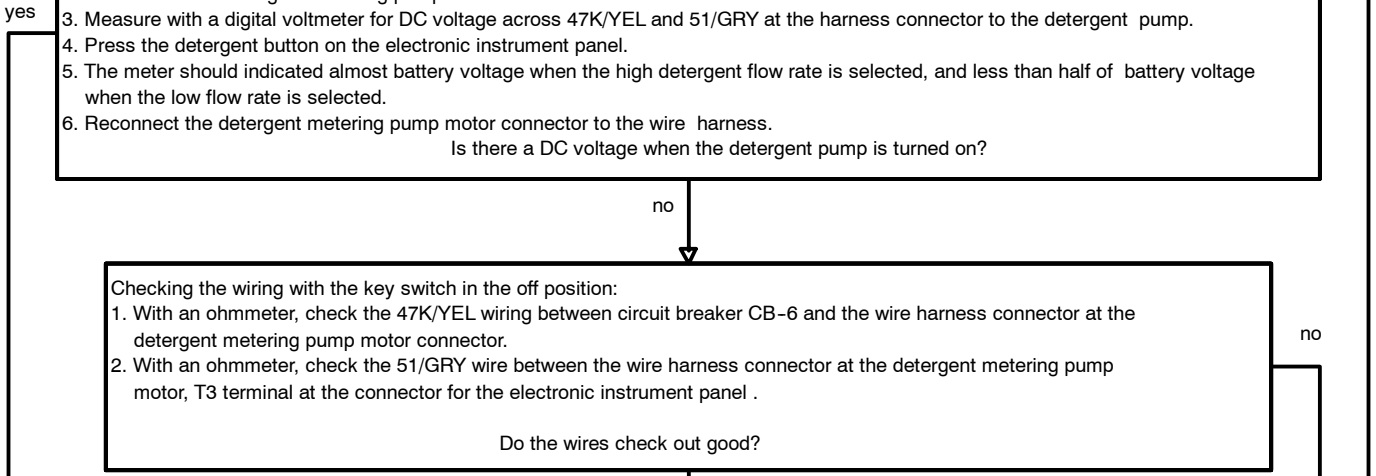

Replace the detergent metering pump motor.

Repair or replace the wires

Solution control works OK

## ES™ WILL NOT OPERATE (8200)

First check for the following:

1. Solution tank not full.
2. Recovery tank level is above the lower level switch point.
3. Solution control rocker switch is on selected to the high or low.

Note: The Extended Scrub (ES) system uses the ES pump to recycle scrub water from the recovery tank to the solution tank. The ES function is enabled by the key switch in the on position, and pressing the ES button on the electronic instrument panel. The solution tank level must be less than full, and the recovery tank level above its lower level switch. The ES pump will continue to run for 40 seconds after the level in the recovery tank has dropped below its lower switch, or after the solution tank level has approached its level switch (solution tank full).

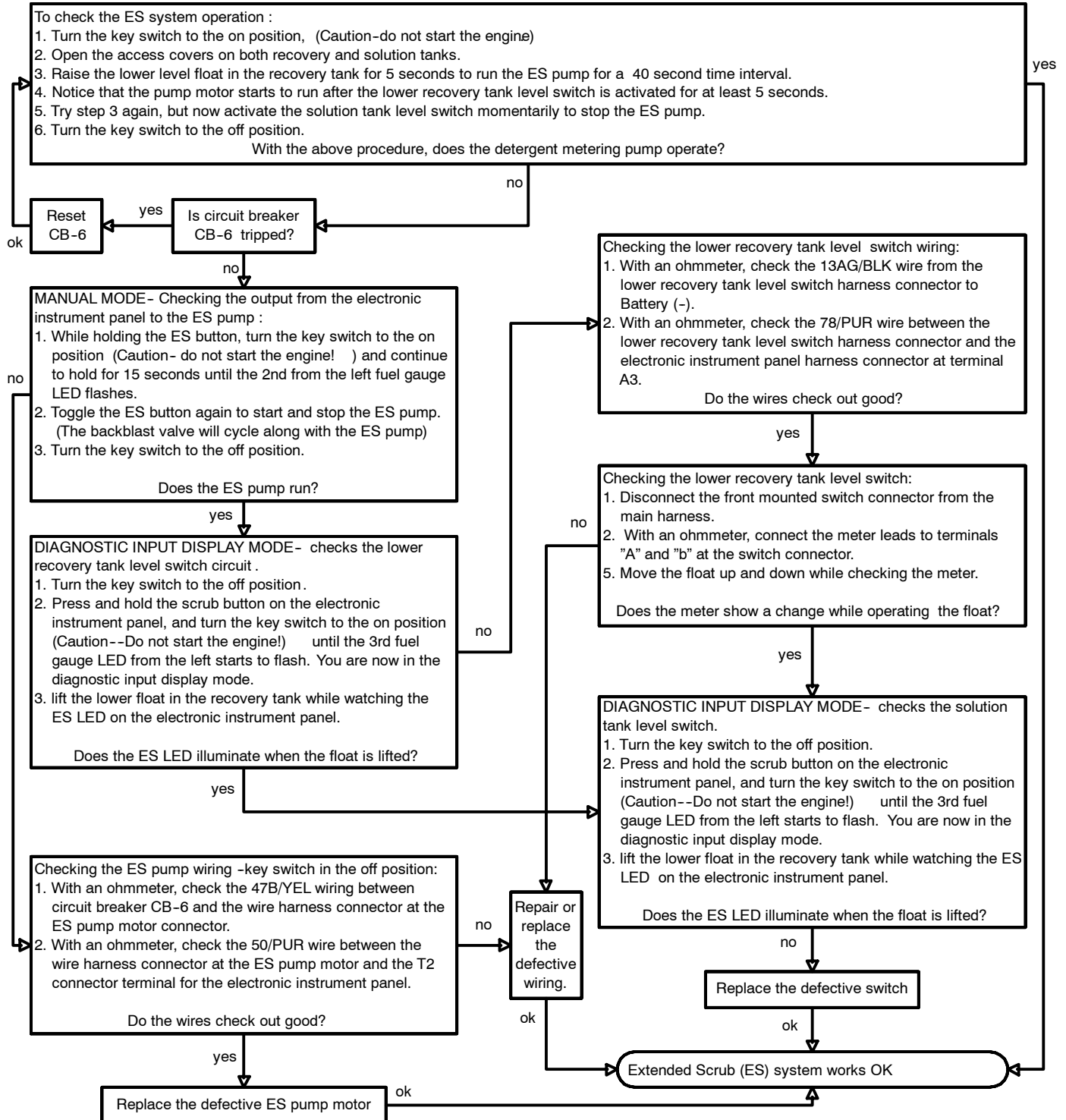

**MAIN SWEEPING BRUSH WILL NOT RUN (8210)**

First check for the following:  
 1. Correct hydraulic oil level  
 2. Engine is runs properly  
 3. Hopper is fully lowered.

Note: Operation of the main sweep brush is dependent upon the hopper down limit switch, and the sweep function enabled.

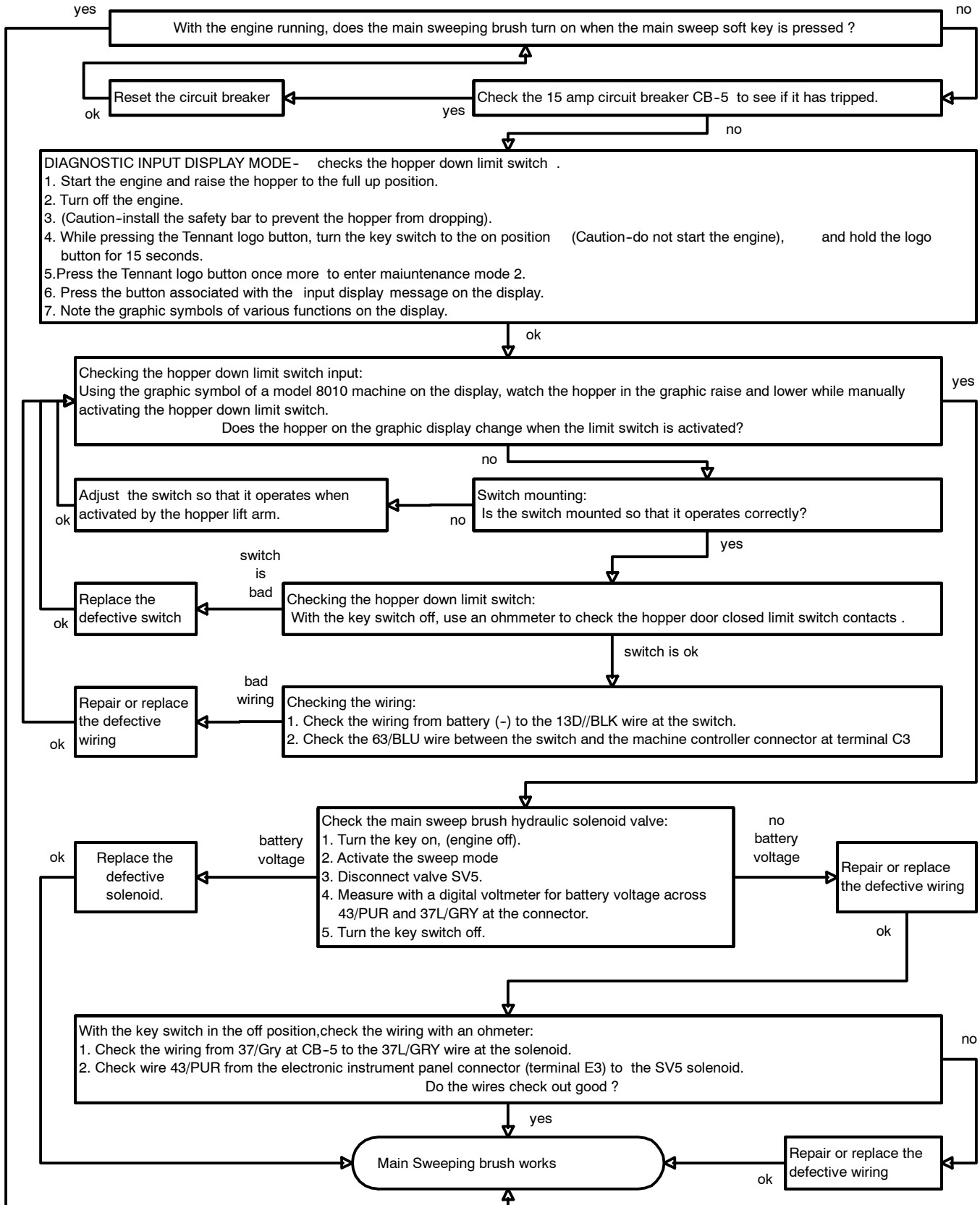

## SIDE BRUSH WILL NOT RUN (8210)

First check for the following:  
 1. Correct hydraulic oil level  
 2. Engine is runs properly  
 3. Hopper is fully lowered

Note: Operation of the side sweep brush is dependent upon the hopper down limit switch, the sweep function enabled, and the side sweep function not disabled.

With the engine running, does the side sweep brush turn on when:  
 1. The sweeping hopper is fully lowered.  
 2. The main sweep function is enabled on the electronic instrument panel.  
 3. The side sweep function is not disabled on the electronic instrument panel.

Reset circuit breaker CB-5

Check the 15 amp circuit breaker CB-5 to see if it has tripped.

**DIAGNOSTIC INPUT DISPLAY MODE**- checks the hopper down limit switch.  
 1. Start the engine and raise the hopper to the full up position.  
 2. Turn off the engine.  
 3. (Caution-install the safety bar to prevent the hopper from dropping).  
 4. While pressing the Tennant logo button, turn the key switch to the on position (Caution-do not start the engine) , hold the logo button for 15 seconds.  
 5. Press the Tennant logo button once more to enter maintenance mode 2.  
 6. Press the button associated with the input display message on the display.  
 7. Note the graphic symbol representations of various machine functions on the display.

Checking the hopper down limit switch input:  
 Using the graphic symbol of a model 8010 machine on the display, watch the hopper in the graphic on the electronic instrument panel raise and lower while manually activating the hopper down limit switch (hopper still in the raised position with the safety bar in place ).  
 Does the hopper on the graphic display move up and down when the limit switch is activated?

Repair or replace the defective wiring

Checking the wiring:  
 1. Turn the key switch to the off position and use an ohmmeter to check the 63/BLU wire from the hopper down limit switch to the C3 terminal of the connector to the electronic instrument panel.  
 2. Check the 13D/BLK wire between the switch and the battery negative(-).

Replace the limit switch

Checking the limit switch:  
 1. With an ohmmeter, check the contacts of the hopper down limit switch.  
 Does the limit switch contacts check out ok?

**MANUAL MODE**- checks the output of the hydraulic side brush solenoid. (Caution-do not start the engine)  
 1. Disconnect the side sweep solenoid (SV-3) and connect a voltmeter to the harness terminals of the 37C/GRY and 46/ORR wires.  
 1. While pressing the Tennant logo button, turn the key switch to the on position and continue to hold the Tennant logo button for 15 seconds.  
 2. Press the button associated with the manual mode message (lower left).  
 3. Press the button associated with the sweeping function graphic (upper right) .  
 4. Repeatedly press the button associated with the side sweep brush function graphic (middle right).  
 6. Check the voltmeter for battery voltage when the side sweep brush function is toggled.  
 7. When the function is active, it is indicated by the graphic of the side sweep brush with a down arrow for on and an up arrow for off.  
 Does the meter indicate battery voltage the side sweep brush function when it is turned on ?

Repair or replace defective wiring between the controller and the solenoid valve

Replace the defective solenoid.

Side Sweeping brush works

# SWEEPING VACUUM FAN WILL NOT RUN (8210)

First check for the following:  
 1. Hydraulic system is functioning properly  
 2. Engine is runs properly  
 3. Hopper is fully lowered

Note: Operation of the sweeping vacuum fan is dependent upon the hopper down switch and the hopper thermal sentry switch.

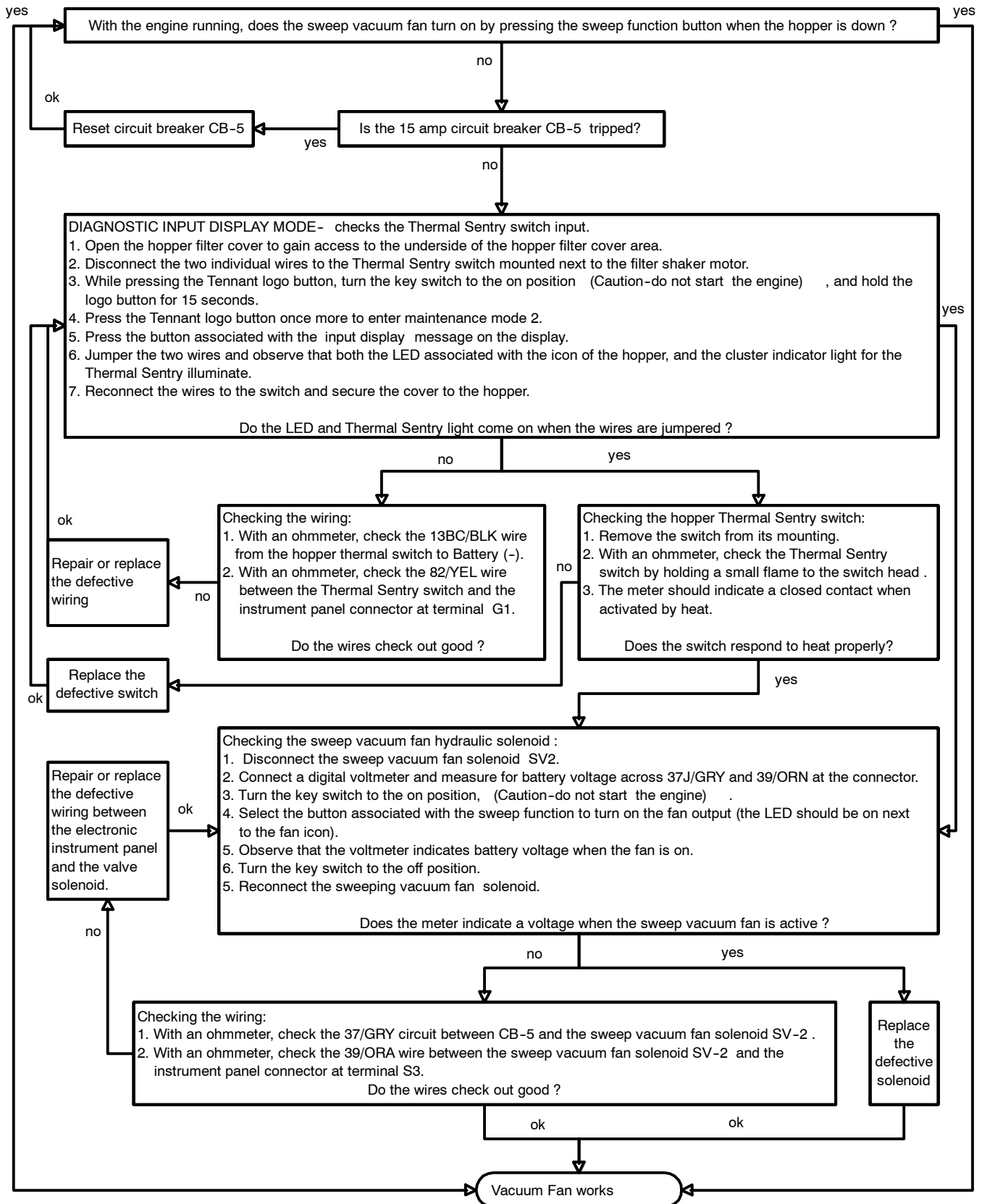

## FILTER SHAKER WILL NOT RUN (8210)

First check for the following:  
 1. The battery is fully charged.  
 2. The Thermal Sentry is functioning

Note: The filter shaker motor normally cycles for 30 seconds each time the sweeping vacuum fan has been shut off.

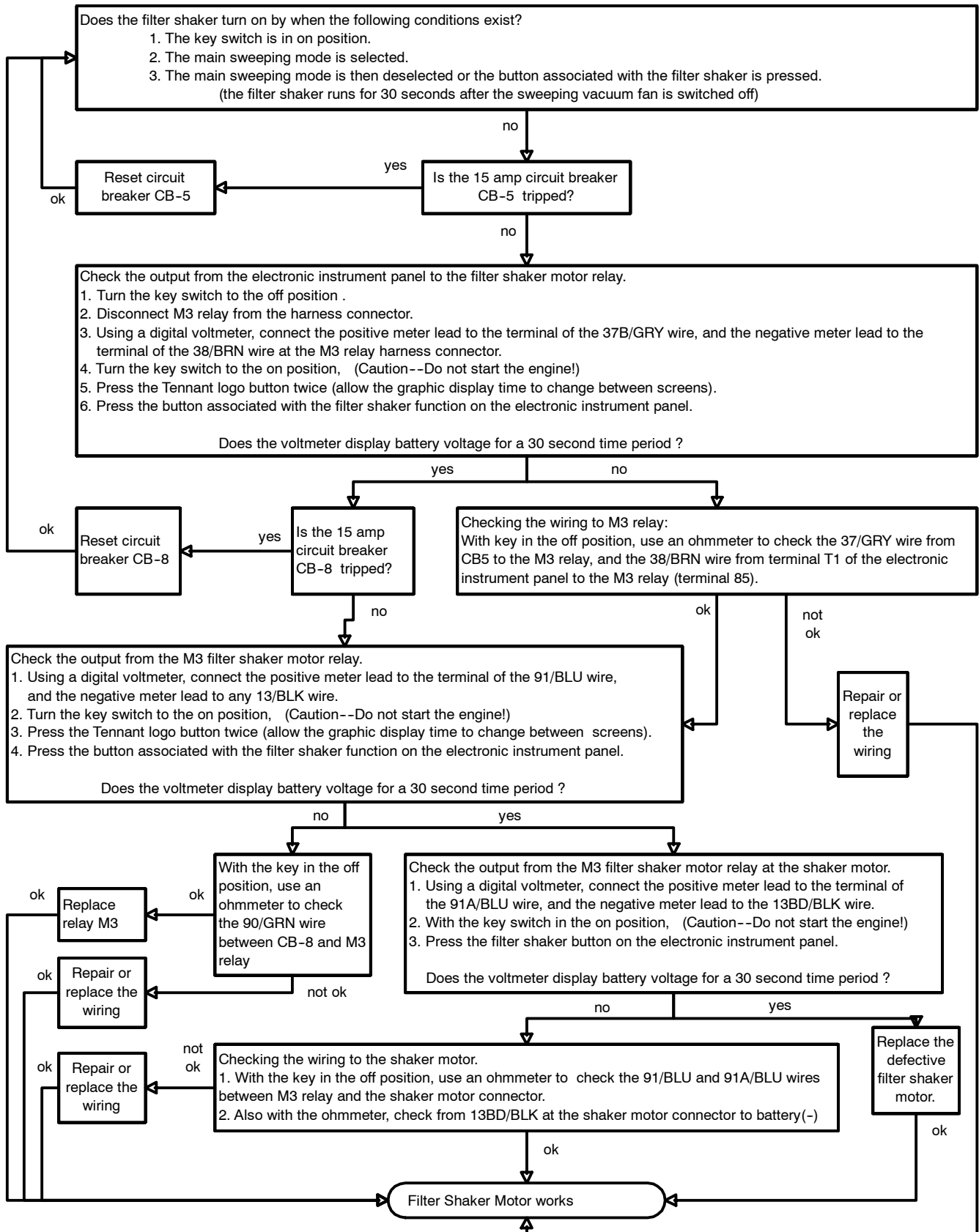



**SCRUB BRUSHES  
WILL NOT RAISE/  
LOWER (8210)**

First check for the following  
1. Correct hydraulic oil level  
2. Propel pedal is enabled  
3. Recovery tank is not full

Note: Normal operation of the scrub brush lift is dependent upon pressing the scrub brush button, activating the forward propel pedal limit switch, the recovery tank is not full, and the engine in the high speed mode.

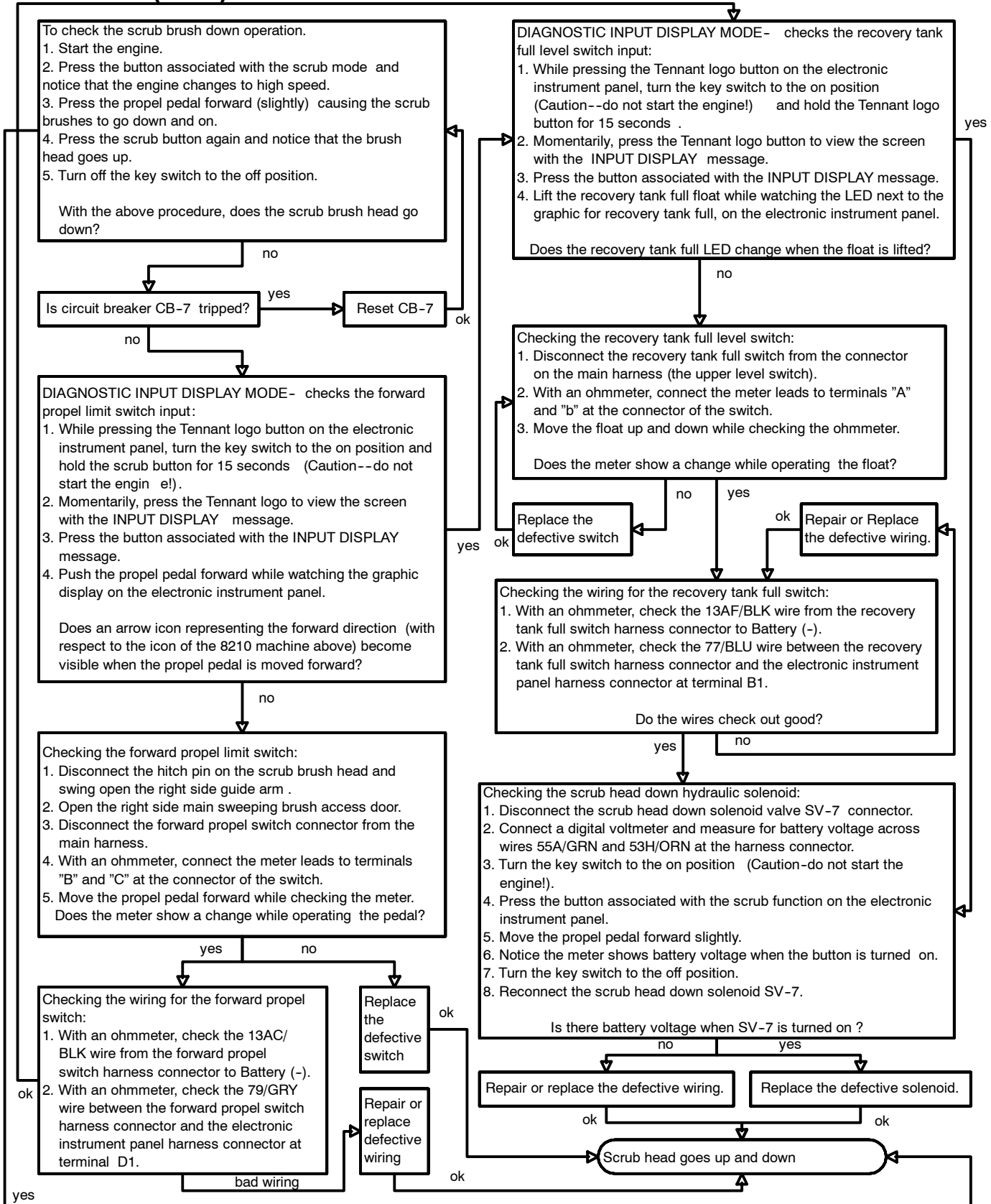

# SCRUB BRUSHES WILL NOT TURN ON (8210)

First check for the following:  
 1. Correct hydraulic oil level  
 2. Propel pedal is enabled  
 3. Recovery tank is not full

Note: Normal operation of the scrub brushes are dependent upon pressing the scrub brush switch, activating the forward propel pedal limit switch, the recovery tank is not full, and the engine in the high speed mode.

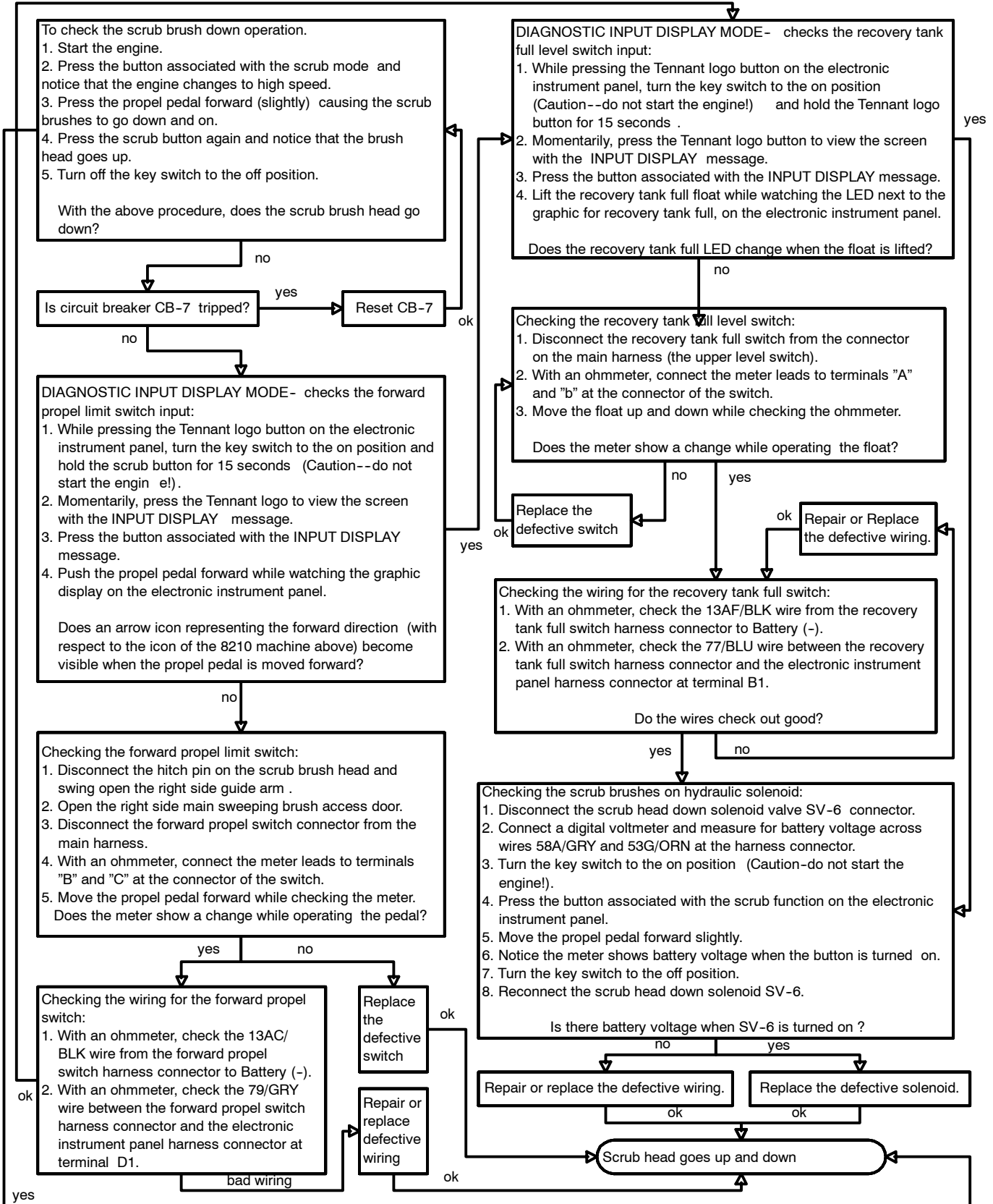

# SCRUB HEAD DOWN FORCE (SV-8) (8210)

First check for the following:  
 1. Correct hydraulic oil level  
 2. Propel pedal is enabled  
 3. Recovery tank is not full

Note: Normal operation to lower the scrub brushes are dependent upon pressing the scrub brush switch, the scrub head down valve SV-7 (see sheet 4.A), the scrub down force solenoid SV-8, activating the forward propel pedal limit switch, the recovery tank is not full, and the engine in the high speed mode.

## A. SCRUB BRUSH HEAD DOWN FORCE ELECTRICAL CHECK

Two visual checks are provided to help determine if the scrub brush down force solenoid SV-8 is working correctly.

1. With the key switch in on position (Caution-Do not start the engine!), the OK message will be visible on the graphic display. If the OK message is not displayed, the electronic instrument panel may be detecting a shorted output and will display the associated output terminal number on the connector for the electronic instrument panel.

For example: a message of "W2" would indicate that the scrub down force solenoid (SV-8) connected to output "W2" of the connector from the electronic instrument panel is short circuited. The fault may be with the solenoid coil or the wiring to the coil.

- 2.
- A. While pressing the Tennant logo button turn the key switch in on position (Caution-Do not start the engine!), and hold the Tennant logo button for 15 seconds.
  - B. Press the button associated with the PRESSURE ADJUSTMENT message on the display.
  - C. Located in the center of the display, a normal condition would be represented by an icon that appears like a vertical fuel gauge.
  - D. When an open circuit is detected, the vertical gauge will be gone, and four small horizontal lines will be displayed where the default down pressure setpoints were previously located.

Check for the following conditions:

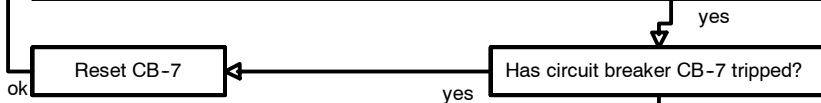

Checking the output to the scrub down pressure valve solenoid:

- 1. Disconnect the SV-8 solenoid from the harness.
- 2. Connect a digital voltmeter to the SV-8 harness connector wires 53J/ORA and 56/BLU.
- 3. Turn the key switch to the on position (Caution, do not start the engine), press the button associated with the scrub function, and move the propel pedal to the forward position.

Does the meter indicate battery voltage?

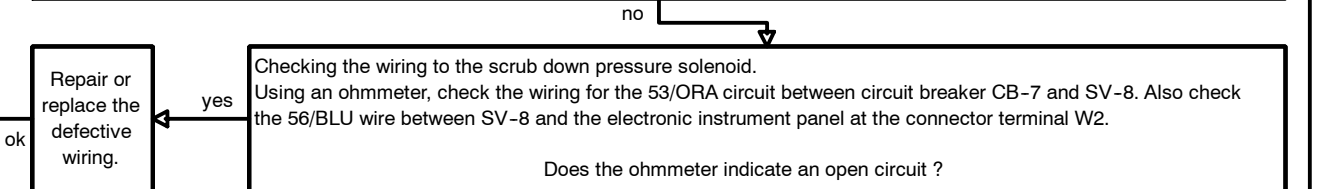

Checking the wiring to the scrub down pressure solenoid. Using an ohmmeter, check the wiring for the 53/ORA circuit between circuit breaker CB-7 and SV-8. Also check the 56/BLU wire between SV-8 and the electronic instrument panel at the connector terminal W2.

Does the ohmmeter indicate an open circuit ?

Replace the solenoid coil.

With a digital ohmmeter, check to see that the resistance of SV-8 is about 7.5 ohms.

Use the following information to see if the down pressure selection setpoints are correct

## B. SCRUB PRESSURE SELECTION- allows the adjustment of down force to the scrub brush head .

The scrub brush system is designed to provide a selection of four increments of down force for a variety of cleaning applications. These four selections are represented by displaying one, two, three, or four arrows above the scrub brush icon on the display. One arrow represents the lowest scrub brush down force applied to the floor, all four arrows displayed would indicate the heaviest scrub brush down force to the floor. Once the selection is made, it will remain stored until another change is made later. The operator can choose the appropriate selection based on the cleaning requirements.

To change the selection:

- 1. Turn the key switch to the on position (is not necessary to start the engine ).
- 2. Press and hold the button associated with the scrub function on the electronic instrument panel to scroll through down pressure settings.
- 3. Release the button when the desired setting is viewed.

Continued on the next page:

## SCRUB HEAD DOWN FORCE (SV-8) (8210)-continued

### C. FACTORY DEFAULT SETPOINTS

The machine has been designed with four standard (default) setpoints that should work well for the majority of applications. These setpoints correspond to the amount of DC current supplied to the down force hydraulic solenoid valve (SV-8) during a scrubbing operation. For most applications, these setpoints should be valid for the life of the machine. Setpoint # 4 is only available when not in the sweeping mode.



### D. SCRUB BRUSH PRESSURE STEEPING CALIBRATION (USING THE BAR GRAPH ON THE DISPLAY). -Allows the adjustment of individual setpoints for each of the four down pressure selections.

In special situations, a customized calibration other than the factory default settings, may be used to provide unique performance characteristics. To change the down pressure setpoints of the:

1. Turn the key switch to the off position.
2. While pressing the Tenant logo button on the instrument panel, turn the key switch to the on position and hold the Tenant logo button for 15 seconds until the display indicates ADJUST PRESSURE (Caution--Do not start the engine!).
3. Press the button associated with the ADJUST PRESSURE message.
4. Notice that the display now has a vertical bar graph with four horizontal divisions. Each division line corresponds to a default steeping value for a down pressure selection. (You are now in the scrub brush down pressure adjustment mode.)
5. To change a default steeping for a down force selection, hold the button associated with the scrub brush to scroll until the desired down force selection is displayed with 1-4 arrows pointing down.
6. Use the two buttons associated with the up and down arrows viewed on the right side of the display to increase or decrease the value of down pressure for that particular down pressure selection as viewed on the bar graph. As either button is held, notice that the bar on the bar graph will change accordingly. (Note: be patient, this adjustment is very slow.)
7. For reference, the measured electrical current values for the factory default setpoints for the four scrub brush down pressure selections are listed below. For exact measurement, these values can be measured with a digital ammeter connected in series with one of the solenoid wires to SV-8.

1st division on the bar graph= 12ma. of current supplied to SV-8.

2nd division on the bar graph= 350ma. of current supplied to SV-8.

3rd division on the bar graph= 647ma. of current supplied to SV-8.

4th division on the bar graph= 751ma. of current supplied to SV-8.



### E. SCRUB PRESSURE SETPOINT CALIBRATION (USING A DIGITAL MULTIMETER)- Checking the down force output from the electronic instrument panel to SV-8, and allows a precise adjustment of individual setpoints for each of the four down pressure selections.

1. Instead of using the fuel gauge LED's for DC current reference to SV-8, this value can be measured by connecting a digital multimeter in series with one of the wires to the coil of SV-8. Use caution when connecting the meter, and select a range to measure 0-1000 milliamperes.
2. Disconnect the scrub down force solenoid SV-8.
3. Install a jumper between the SV-8 connector and the harness connector for SV-8, that will enable a series connection for measuring the DC current through one of the wires to the SV-8 solenoid coil with a digital multimeter.
4. Enter the scrub force adjustment mode using the procedure outlined above.
5. Choose the the desired down force selection.
6. While observing the meter, adjust the setpoints to the desired values using the default information in D.7 above for reference.:
  - a. Press and hold the button associated with the up arrow to increase the scrub brush down force selection setpoint. This will increase the DC current to SV-8 for that selection as indicated on the meter and the vertical bar graph.
  - b. Press and hold the button associated with the down arrow to decrease the scrub brush down force selection setpoint. This will decrease the DC current to SV-8 for that selection as indicated on the meter and the vertical bar graph.
  - c. After adjusting each selection for its desired setpoint, press the button associated with the scrub button to scroll to the next selection as indicated by the arrows above the scrub brush icon on the display.
  - d. When each of the selections have the desired setpoint, Press the button associated with the EXIT message on the display.



### F. RESTORE THE ELECTRONIC INSTRUMENT PANEL TO THE FACTORY DEFAULT SETPOINTS

1. Turn the key switch to the off position.
2. While pressing the Tennant logo button on the instrument panel, turn the key switch to the on position and hold the Tennant logo button for 15 seconds until the display indicates RESET SCRUB PRESSURE (Caution--Do not start the engine!).
3. Press the button associated with the RESET SCRUB PRESSURE message.
4. Press the button associated with the YES message.
5. The control will exit this mode automatically and return to the operating mode.

**SCRUB HEAD  
EDGE SCRUB  
WILL NOT  
SHIFT (8210)**

- First check for the following:
1. Machine is equipped with a MAXPRO 1000 scrub head.
  2. The edge scrub feature is enabled
  3. Correct hydraulic oil level
  4. Recovery tank is not full

Note: Normal operation of the scrub brush shift is dependent upon being in the scrub mode, activating the forward propel pedal limit switch, the recovery tank is not full, and the engine in the high speed mode.

Edge scrub feature:  
The edge scrub feature is available on the 8210 when equipped with a scrub head using only two scrub brushes. By activating the edge scrub function, the scrub head moves laterally allowing the machine to scrub closer to walls on the right hand side. If the electronic instrument panel has been replaced, it may be necessary to reset this feature to match the configuration of the machine. Machines that have this feature enabled, are recognizable with an icon located in the mid left area of the graphic display during the scrub mode. The icon resembles a brush with a horizontal arrow pointing in the direction of the present position of the scrub brush head.

- To configure the electronic instrument panel for the edge scrub function:
1. While pressing the Tennant logo button turn the key switch to on position (Caution-Do not start the engine!) , and hold the Tennant logo button for 15 seconds.
  2. Press the Tennant logo button again to display the EDGE SCRUB message.
  3. Press the button associated with the EDGE SCRUB message.
  4. Observe that the display provides a choice of YES or NO to enable the edge scrub function.
  5. Press the associated button for the desired configuration choice.

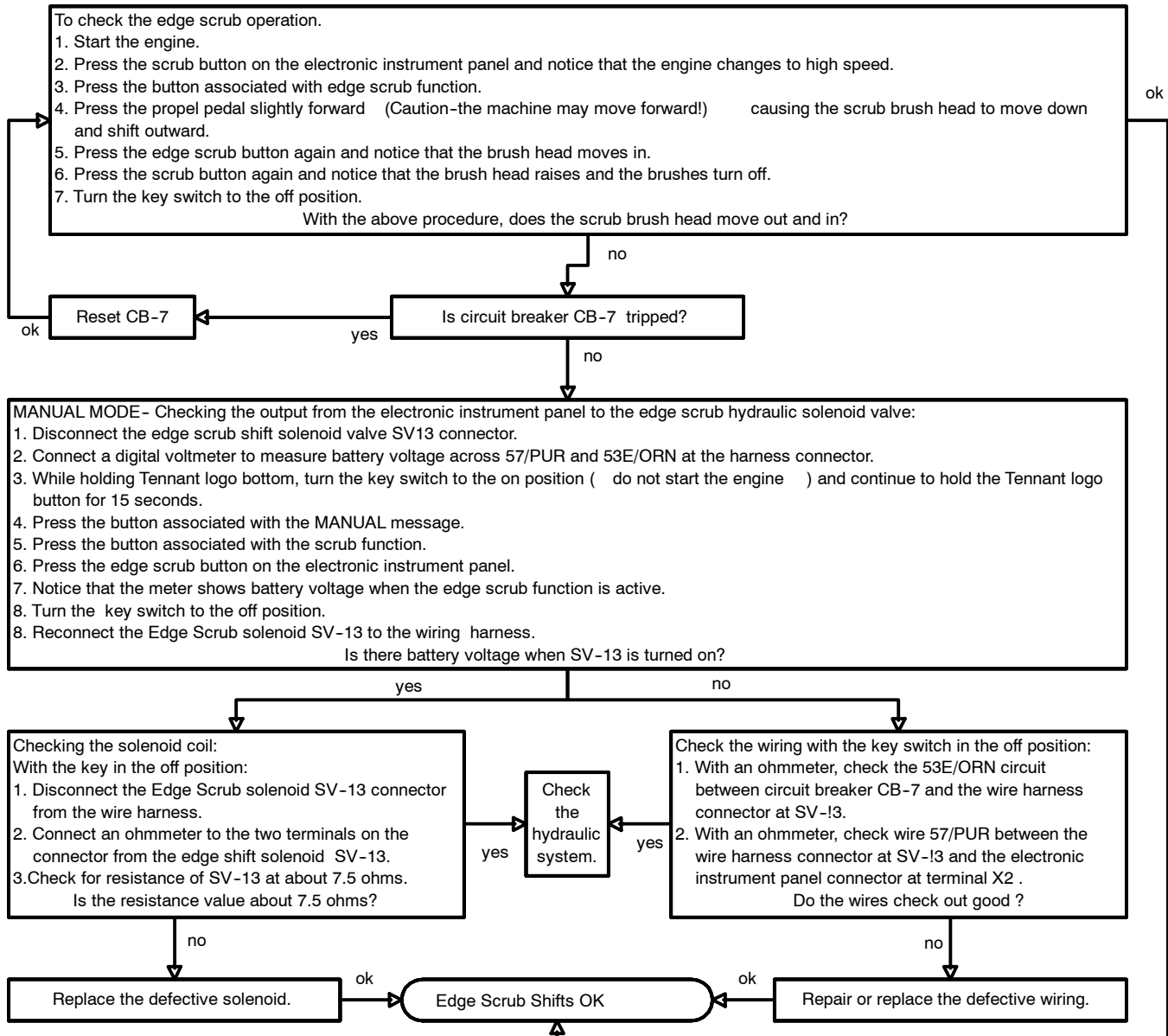

## SQUEEGEE WILL NOT LOWER (8210)

First check for the following:

1. Correct hydraulic oil level
2. Propel pedal is not in reverse
3. Recovery tank is not full

Note: Normal operation of the squeegee lower function is dependent upon pressing the scrub or squeegee button, activating the forward or reverse propel pedal limit switch, the recovery tank is not full, and the engine in the high speed mode.

To check the squeegee lower operation.

1. Start the engine.
2. Press the squeegee button on the electronic instrument panel and notice that the engine changes to high speed.
3. The vacuum fan will turn on and the squeegee will move down.
4. Move the propel pedal slightly to reverse (Caution- the machine may move!) and notice that the squeegee moves up.
5. Turn the key switch to the off position.

With the above procedure, does the scrub brush head move out and in?

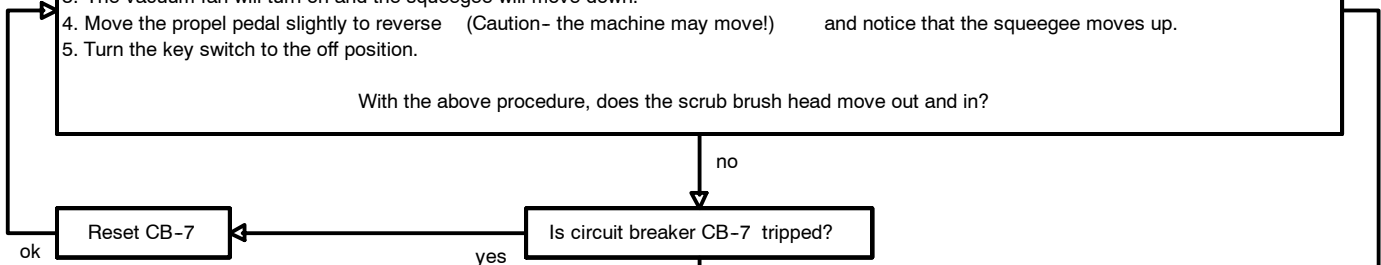

MANUAL MODE- Checking the output from the electronic instrument panel to the squeegee lower hydraulic solenoid valve:

1. Disconnect the squeegee lower solenoid valve SV-4 connector.
2. Connect a digital voltmeter to measure battery voltage across 54/YEL and 53F/ORN at the harness connector.
3. While holding the Tennant logo button, turn the key switch to the on position (do not start the engine) and continue to hold the Tennant logo button for 15 seconds.
4. Press the squeegee button on the electronic instrument panel.
5. Observe that the meter shows battery voltage when the squeegee function is selected.
6. Turn the key switch to the off position.
7. Reconnect the squeegee lower solenoid SV-4 to the wiring harness.

Is there battery voltage when SV-4 is turned on?

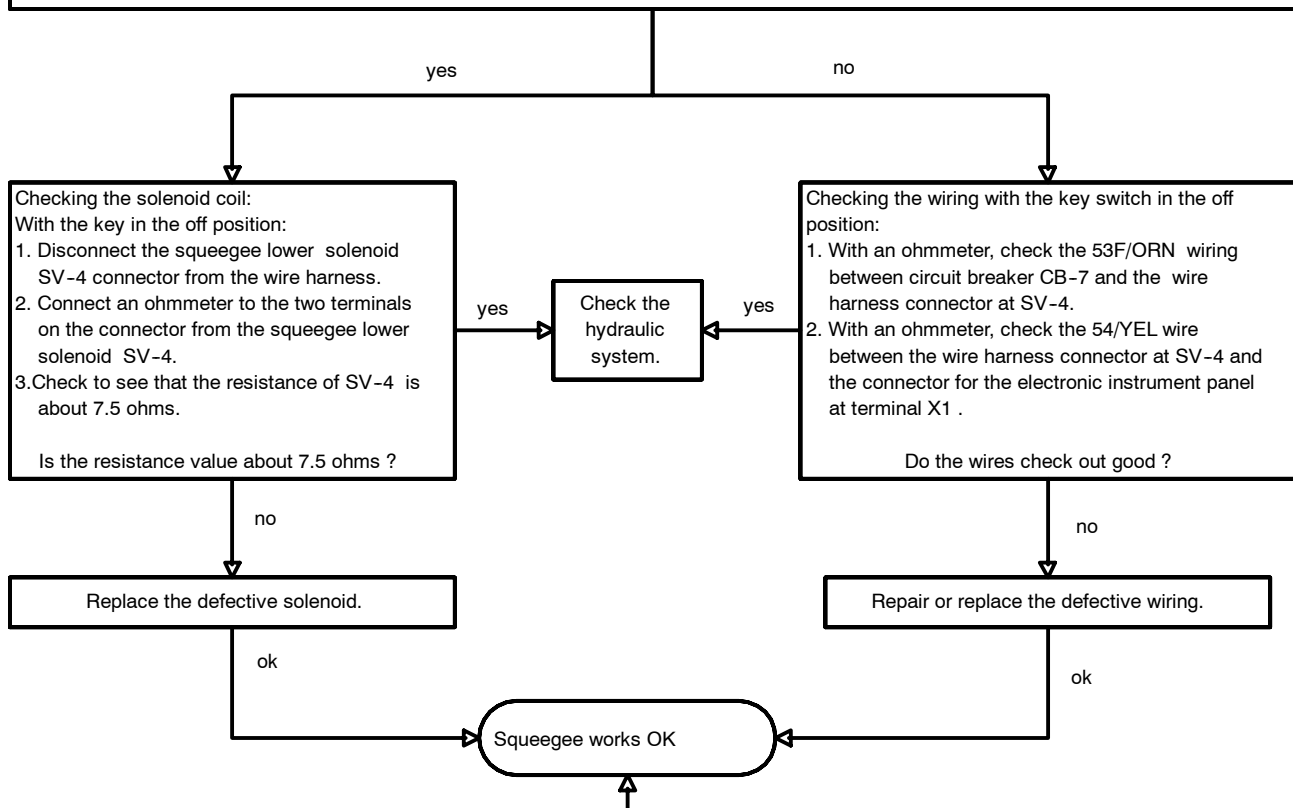

**SCRUB VACUUM FAN WILL NOT RUN (8210)**

First check for the following:  
 1. Correct hydraulic oil level  
 2. Recovery tank is not full  
 3. Vacuum lines are not restricted

Note: Normal operation of the scrub vacuum fan function is dependent upon having the scrub or squeegee mode active, activating the forward or reverse propel pedal limit switches, the recovery tank is not full, and the engine in the high speed mode.

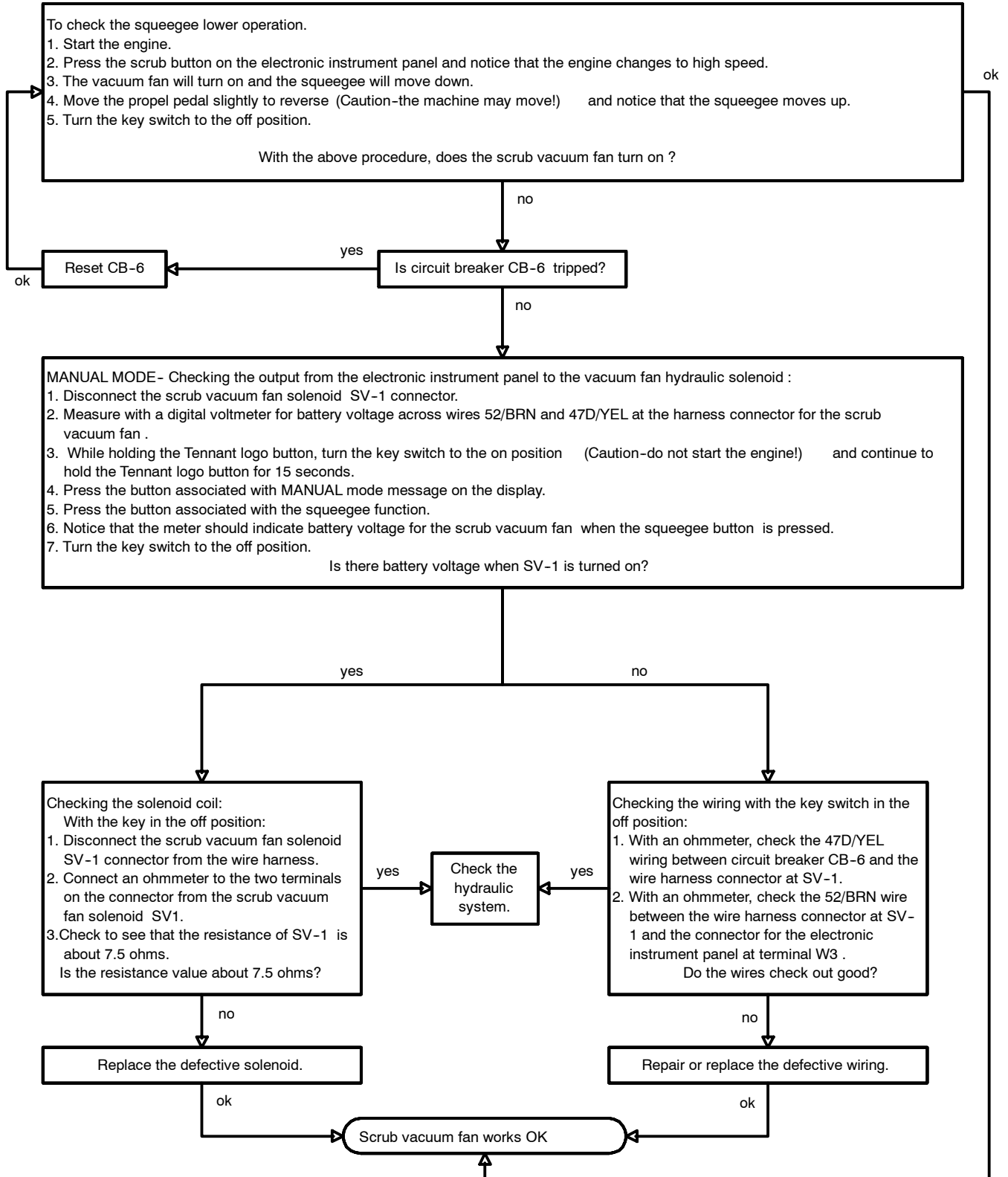

## SOLUTION CONTROL WILL NOT OPERATE (8210)

First check for the following:  
 1. Correct solution tank level  
 2. Recovery tank is not full  
 3. Solution lines are not restricted

Note: Normal operation for the scrub solution control is dependent upon pressing the scrub button, activating the forward or reverse propel pedal limit switches, the recovery tank is not full, and the engine in the high speed mode.

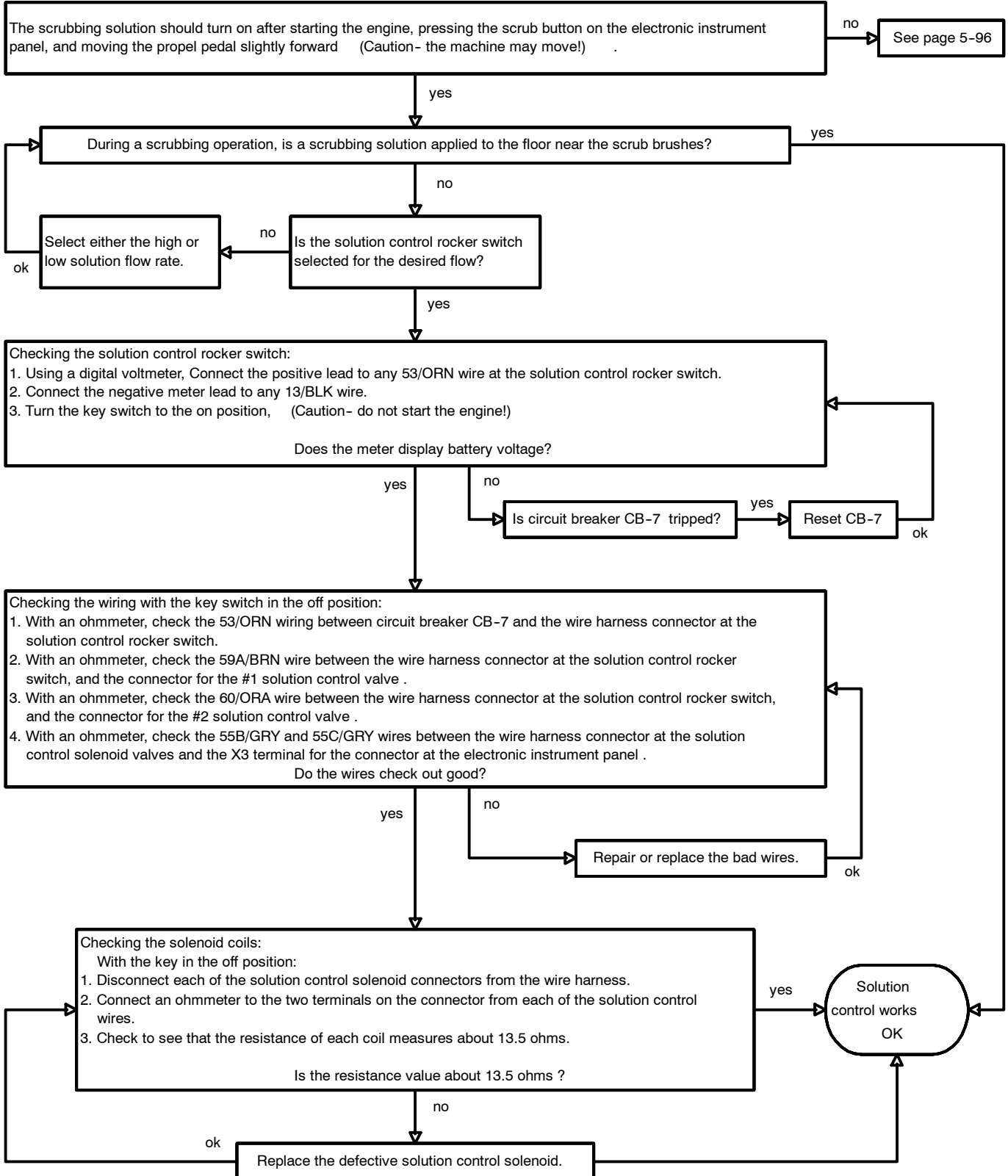



**DETERGENT PUMP  
WILL NOT  
OPERATE (8210)**

- First check for the following:
1. Correct detergent tank level
  2. Recovery tank is not full
  3. Solution switch is on high or low

Note: Normal operation of the detergent metering pump requires that one of the detergent flow rates is selected on the electronic instrument panel, the solution control rocker switch must be set to high or low, and operating in the scrub mode with the machine propelling forward.

To check the detergent metering pump operation :

1. Disconnect the hitch pin on the scrub brush head and swing open the right side guide arm .
2. Open the right side main sweeping brush access door.
3. Find the detergent metering pump located under the floor, just below the foot pedals
3. Turn the key switch to the on position (Caution-do not start the engine!).
4. Press the button associated with the scrub function on the electronic instrument panel.
5. Select the solution control rocker switch to either high or low flow .
6. Press the button associated with the detergent metering function on the electronic instrument panel to either high or low flow.
7. Move the propel pedal slightly to the forward direction.
8. Notice if the pump motor is running.
9. Turn off the key switch to the off position.

With the above procedure, does the detergent metering pump operate ?

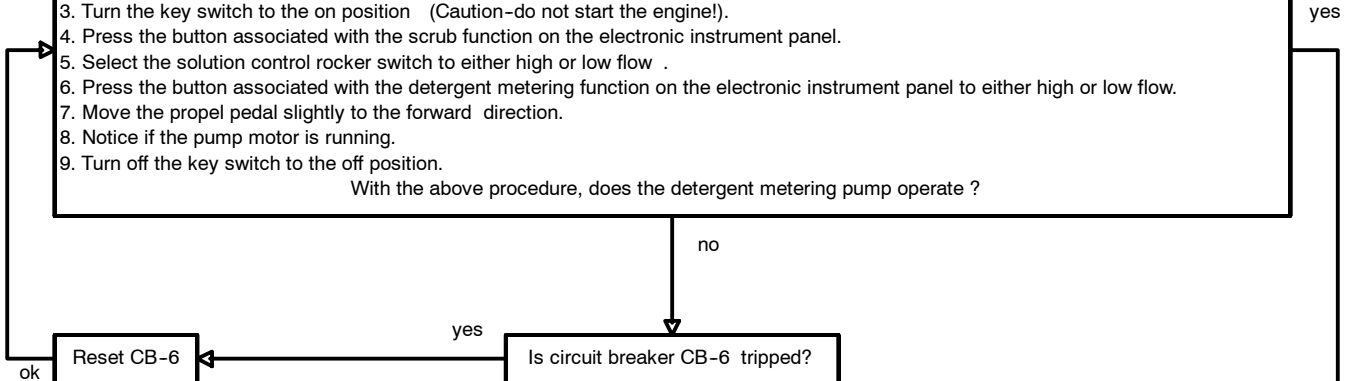

MANUAL MODE- Checking the output from the electronic instrument panel to the edge scrub hydraulic solenoid valve:

1. Disconnect the detergent metering pump motor connector from the wire harness.
2. Measure with a digital voltmeter for DC voltage across 47K/YEL and 51/GRY at the harness connector to the detergent pump.
3. Press the detergent button on the electronic instrument panel.
4. While holding the Tennant logo button, turn the key switch to the on position (Caution-do not start the engine!) and continue to hold the Tennant logo button for 15 seconds.
5. The meter should indicated almost battery voltage when the high detergent flow rate is selected, and less than half of battery voltage when the low flow rate is selected.

Is there a DC voltage when the detergent pump is turned on ?

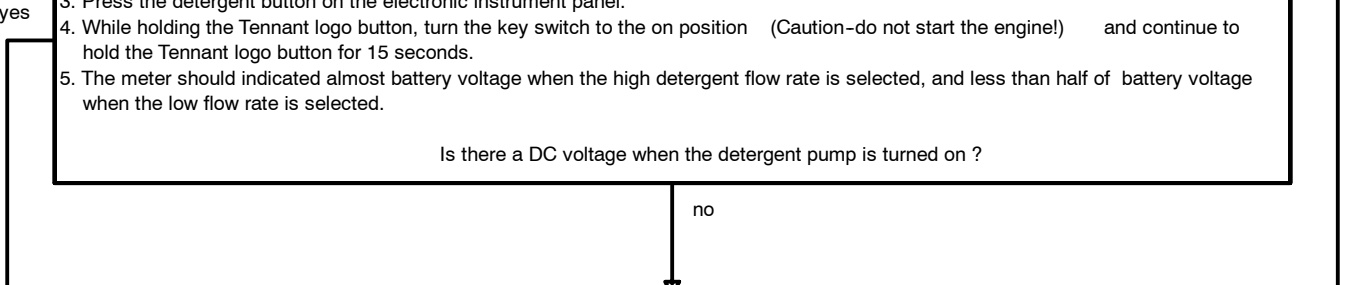

Checking the wiring with the key switch in the off position:

1. With an ohmmeter, check the 47K/YEL wiring between circuit breaker CB-6 and the wire harness connector at the detergent metering pump motor connector.
2. With an ohmmeter, check the 51/GRY wire between the wire harness connector at the detergent metering pump motor, and the T3 terminal at the connector for the electronic instrument panel .

Do the wires check out good ?

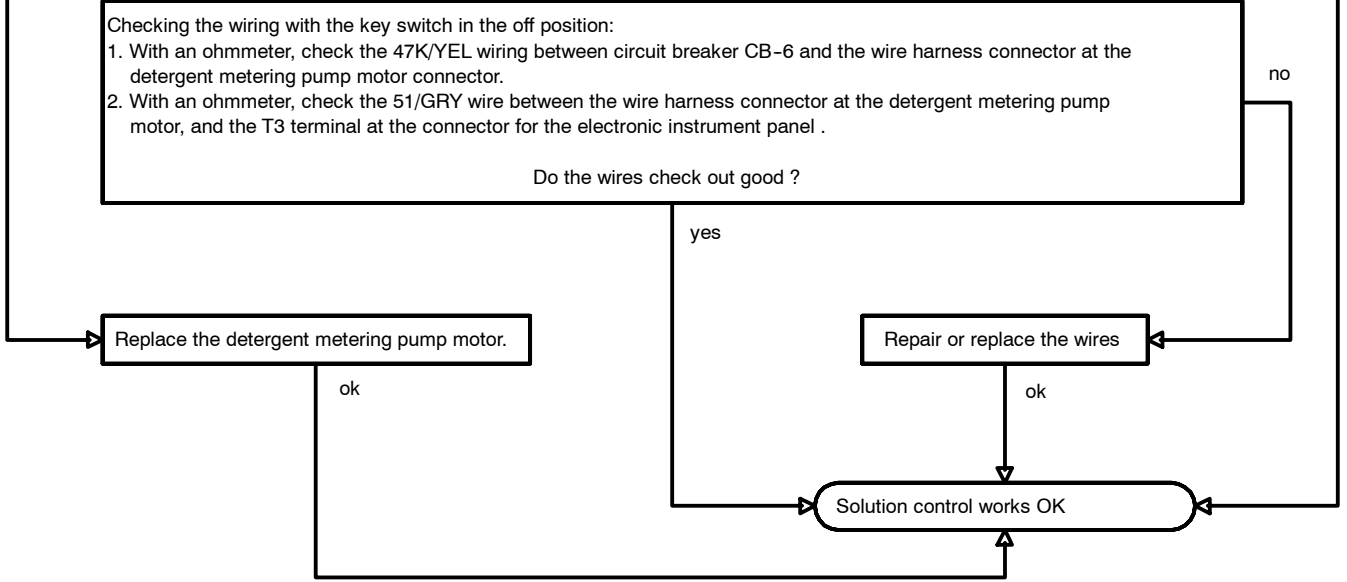

## ES™ WILL NOT OPERATE (8210)

First check for the following:  
 1. Solution tank is not full.  
 2. Recovery tank level is above the lower level switch point.

Note: The Extended Scrub (ES) system uses the ES pump to recycle scrub water from the recovery tank back to the solution tank. The ES function is enabled by the key switch in the on position, and pressing the ES button on the electronic instrument panel. The solution tank level must be less than full, and the recovery tank level above its lower level switch. The ES pump will continue to run for 40 seconds after the level in the recovery tank has dropped below its lower switch, or after the solution tank level has approached its level switch (solution tank full).

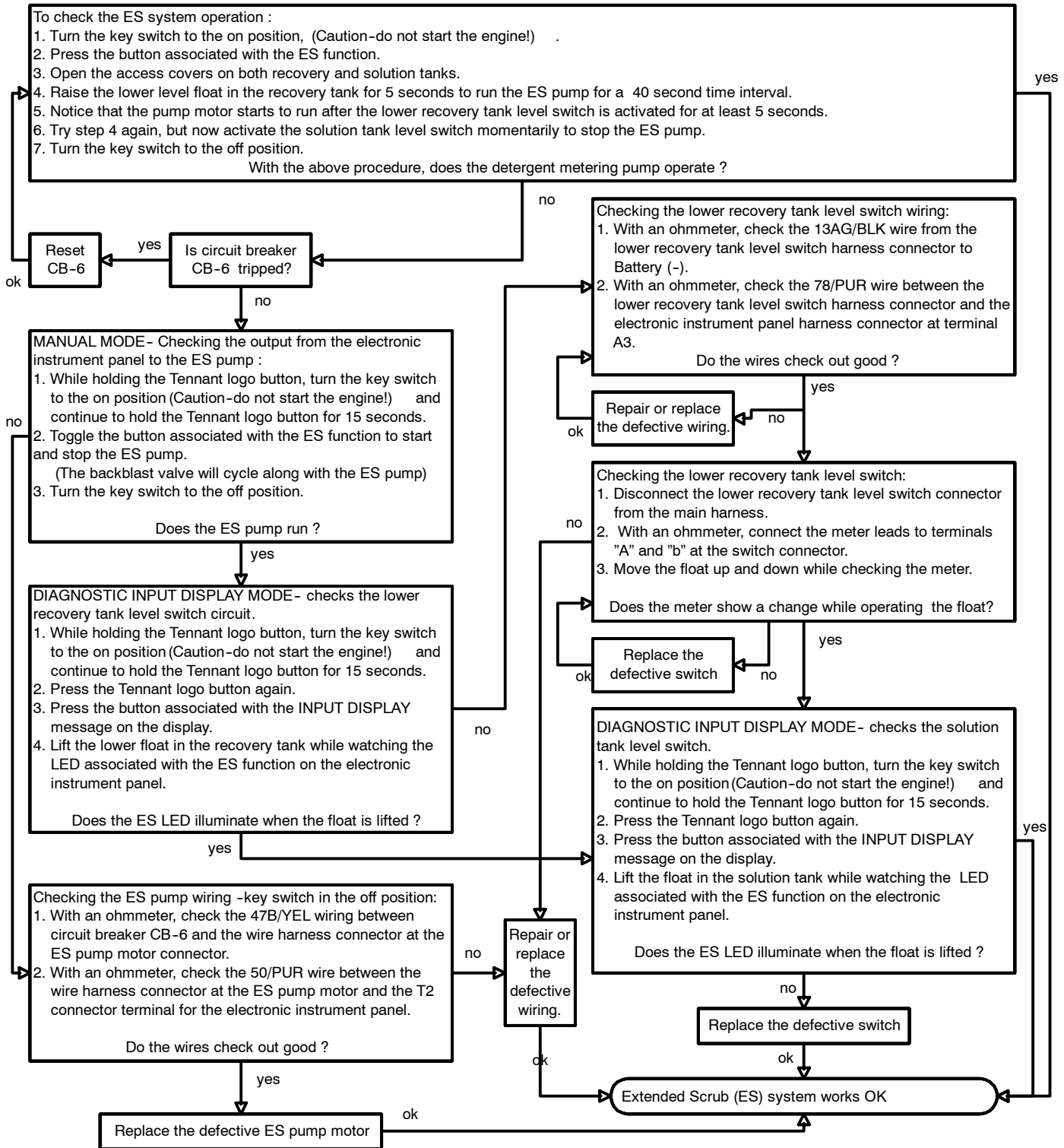

**CONTENTS**

	Page		Page
INTRODUCTION .....	6-3	TO REPLACE SWEEPING VACUUM FAN	
HYDRAULIC FLUID RESERVOIR .....	6-4	MOTOR .....	6-100
HYDRAULIC HOSES .....	6-4	TO REPLACE SCRUBBING VACUUM FAN	
HYDRAULIC FLUID .....	6-5	MOTOR .....	6-103
TO DRAIN HYDRAULIC FLUID RESERVOIR		TO REPLACE REAR DRIVE MOTOR ....	6-106
AND REPLACE FILTER ELEMENT ..	6-6	HYDRAULIC SCHEMATIC .....	6-112
TO FILL HYDRAULIC FLUID		HYDRAULIC HOSE DIAGRAM (8200) ...	6-114
RESERVOIR .....	6-8	HYDRAULIC HOSE DIAGRAM (8210) ...	6-116
HYDRAULIC PUMPS .....	6-9	TROUBLESHOOTING .....	6-119
TO REPLACE PROPEL PUMP .....	6-9	POWER STEERING IS NOT NORMAL	6-120
TO REPLACE PRIMARY ACCESSARY		SCRUB HEAD WILL NOT RAISE ....	6-121
PUMP .....	6-14	SCRUB HEAD WILL NOT LOWER ...	6-122
TO REPLACE BELT DRIVEN		SCRUB HEAD WILL NOT STAY UP ..	6-123
ACCESSARY PUMP .....	6-17	MAIN BROOM WILL NOT TURN ON .	6-124
TO REPLACE BELT DRIVEN		MAIN BROOM WILL NOT TURN OFF	6-125
ACCESSARY PUMP V-BELT .....	6-27	SCRUB BRUSHES WILL NOT	
DIRECTIONAL PEDAL .....	6-31	TURN ON .....	6-126
TO REPLACE PROPEL DIRECTIONAL		SCRUB BRUSHES WILL NOT	
SPRING .....	6-31	TURN OFF .....	6-127
TO REPLACE PROPEL DIRECTIONAL		SQUEEGEE WILL NOT RAISE .....	6-128
CABLE .....	6-35	SQUEEGEE WILL NOT LOWER .....	6-129
TO ADJUST NEUTRAL CENTERING ..	6-41	SQUEEGEE WILL NOT STAY UP ....	6-130
TO REPLACE HOPPER LIFT		SCRUB FAN WILL NOT TURN ON ...	6-131
CYLINDER .....	6-43	SCRUB FAN WILL NOT TURN OFF ..	6-132
TO REPLACE HOPPER DUMP		SWEEP FAN WILL NOT TURN ON ...	6-133
DOOR CYLINDER .....	6-47	SWEEP FAN WILL NOT TURN OFF ..	6-134
TO REPLACE MAIN BRUSH LIFT		SIDE BRUSH WILL NOT TURN ON ..	6-135
CYLINDER (8210 only) .....	6-49	SIDE BRUSH WILL NOT TURN OFF .	6-136
TO REPLACE SIDE BRUSH LIFT		HOPPER DOOR WILL NOT CLOSE ..	6-137
CYLINDER (8210 only) .....	6-52	HOPPER DOOR WILL NOT STAY	
TO REPLACE SCRUB HEAD SIDE SHIFT		CLOSED .....	6-138
CYLINDER (optional on 8200,		HOPPER WILL NOT RAISE .....	6-139
std on 8210) .....	6-55	HOPPER WILL NOT HOLD UP	
TO REPLACE SCRUB HEAD		POSITION .....	6-140
LIFT CYLINDER .....	6-58	HOPPER WILL NOT LOWER .....	6-141
TO REPLACE REAR SQUEEGEE LIFT		SCRUB HEAD WILL NOT GO OUT	
CYLINDER .....	6-61	(edge scrub option) .....	6-142
TO REPLACE STEERING CYLINDER .	6-65	SCRUB HEAD WILL NOT GO IN	
TO REPLACE STEERING VALVE .....	6-70	(edge scrub option) .....	6-143
HOPPER LIFT VALVE .....	6-73	MAIN BRUSH WILL NOT GO DOWN	
TO REPLACE HOPPER LIFT VALVE ..	6-73	(8210 only) .....	6-144
HYDRAULIC SOLENOID VALVES .....	6-77	MAIN BRUSH WILL NOT GO UP	
TO REPLACE BRUSH AND VACUUM		(8210 only) .....	6-145
FAN SOLENOID VALVES .....	6-77	SIDE BRUSH WILL NOT GO DOWN	
TO REPLACE OPTIONAL SCRUB HEAD		(8210 only) .....	6-146
SIDE SHIFT SOLENOID		SIDE BRUSH WILL NOT GO UP	
VALVE (8210) .....	6-82	(8210 only) .....	6-147
TO REPLACE SIDE BRUSH/MAIN BRUSH		HOPPER DOOR WILL NOT CLOSE	
LIFT, HOPPER DOOR OPEN/CLOSE		(8210 only) .....	6-148
SOLENOID VALVE (8210) .....	6-86	HOPPER DOOR WILL NOT STAY	
TO REPLACE MAIN SWEEPING BRUSH		CLOSED (8210 only) .....	6-149
MOTOR .....	6-90	HOPPER DOOR WILL NOT OPEN	
TO REPLACE SIDE BRUSH MOTOR ..	6-94	(8210 only) .....	6-150
TO REPLACE SCRUB BRUSH		PROPEL MOTOR WILL NOT	
MOTOR .....	6-97	PROPEL .....	6-151



---

**INTRODUCTION**

---

The 8200/8210 hydraulic system consists of the lift cylinders, hydraulic motors, hydraulic pumps, and hydraulic valves. This section includes information on these components and their troubleshooting.

# HYDRAULICS

## HYDRAULIC FLUID RESERVOIR

Check the hydraulic fluid level at operating temperature every 100 hours of operation. Make sure the hopper is down when checking hydraulic fluid level. The end of the dipstick is marked with FULL and ADD levels to indicate the level of hydraulic fluid in the reservoir.

Lubricate the filler cap gasket with a film of hydraulic fluid before putting the cap back on the reservoir.

**ATTENTION! Do not overfill the hydraulic fluid reservoir or operate the machine with a low level of hydraulic fluid in the reservoir. Damage to the machine hydraulic system may result.**

Drain and refill the hydraulic fluid reservoir with new hydraulic fluid every 800 hours of operation.

The hydraulic fluid filter is located at the bottom of the engine compartment. Replace the filter element every 800 hours of operation.

The reservoir has a built-in strainer outlet that filters hydraulic fluid before it enters the system. Replace the strainer every 800 hours of operation.

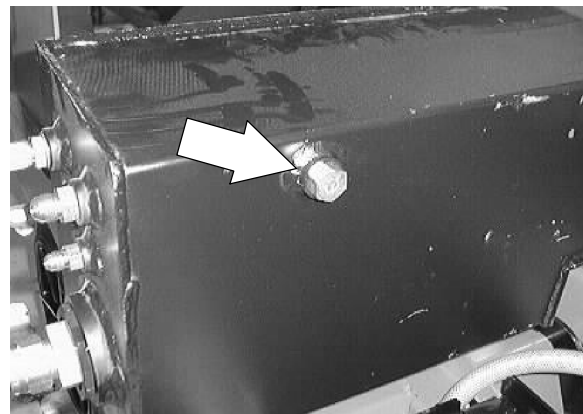

## HYDRAULIC HOSES

Check the hydraulic hoses every 800 hours of operation for wear or damage.

Fluid escaping at high pressure from a very small hole can be almost invisible, and can cause serious injuries.

See a doctor at once if injury results from escaping hydraulic fluid. Serious infection or reaction can develop if proper medical treatment is not given immediately.

**FOR SAFETY: When servicing machine, use cardboard to locate leaking hydraulic fluid under pressure.**

If you discover a fluid leak, contact your mechanic/supervisor.

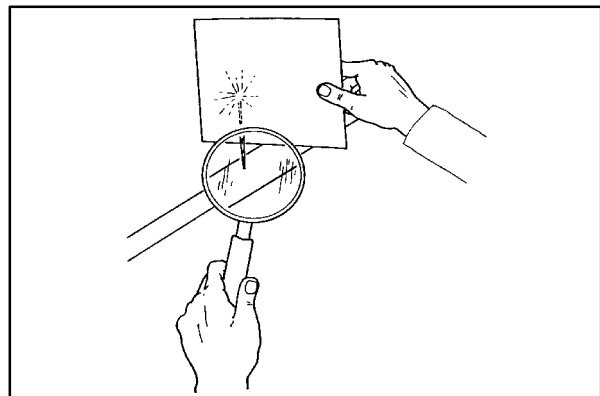

## HYDRAULIC FLUID

The quality and condition of the hydraulic fluid play a very important role in how well the machine operates. TENNANT's hydraulic fluid is specially selected to meet the needs of TENNANT machines.

TENNANT's hydraulic fluids provide a longer life for the hydraulic components. There are two fluids available for different temperature ranges:

Tennant part no.	Ambient Temperature
65869	above 7° C (45° F)
65870	below 7° C (45° F)

The higher temperature fluid has a higher viscosity and should not be used at the lower temperatures. Damage to the hydraulic pumps may occur because of improper lubrication.

The lower temperature fluid is a thinner fluid for colder temperatures.

If a locally-available hydraulic fluid is used, make sure the specifications match TENNANT hydraulic fluid specifications. Using substitute fluids can cause premature failure of hydraulic components.

European manufactured machines are filled with locally available hydraulic fluids. Check the label on the hydraulic fluid reservoir.

**ATTENTION! Hydraulic components depend on system hydraulic fluid for internal lubrication. Malfunctions, accelerated wear, and damage will result if dirt or other contaminants enter the hydraulic system.**



## HYDRAULICS

### TO DRAIN HYDRAULIC FLUID RESERVOIR AND REPLACE FILTER ELEMENT

1. Stop the engine and set the machine parking brake.

**FOR SAFETY: Before Leaving Or Servicing Machine; Stop On Level Surface, Set Parking Brake, Turn Off Machine And Remove Key.**

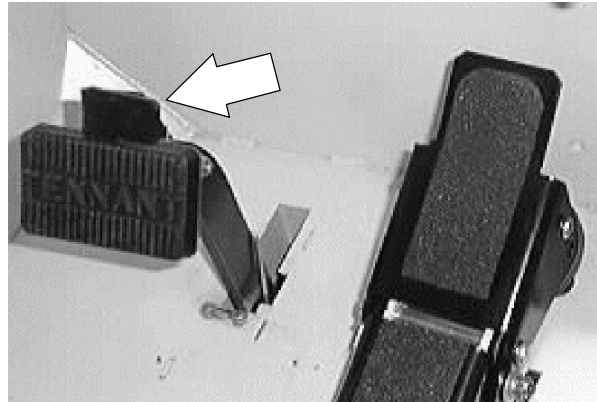

2. Open the engine cover and side door.
3. Wait for the hydraulic fluid to cool down.



4. Remove the drain plug from the bottom of the hydraulic tank (above LH side squeegee) on the left hand side of the machine. Drain the fluid into a pan. Properly discard the old fluid.





5. Locate the hydraulic oil filter at the front side of the main hydraulic pump, behind the solution tank.
6. Unthread and discard the hydraulic fluid filter element.

*NOTE: Hydraulic fluid will drain through the filter head.*

7. Discard the used hydraulic fluid. Loosen the breather-filler cap.

*NOTE: Be aware the hydraulic filter is lower than the reservoir. All fluid will drain from the reservoir. Discard all hydraulic fluid drained from the system. The fluid may contain foreign material harmful to the hydraulic system.*

8. Apply a thin coat of hydraulic fluid to the seal of the new hydraulic fluid filter element.
9. Thread and hand tighten the new hydraulic fluid filter element on the filter head.
10. Refill the hydraulic reservoir.

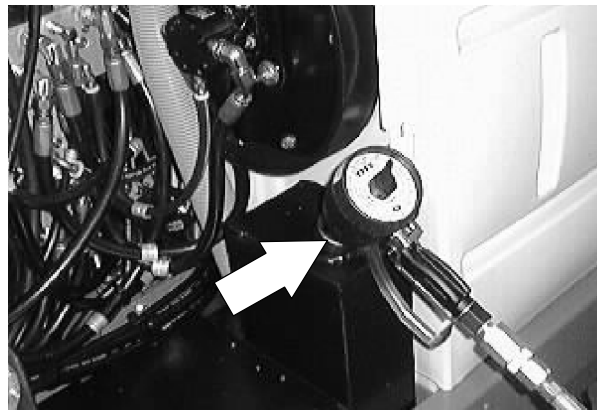
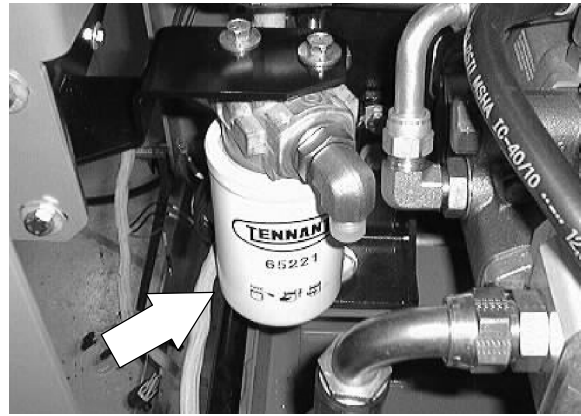

11. Close the engine side door and engine cover. Operate the machine and its functions. Re-check the hydraulic fluid level, add fluid if necessary.

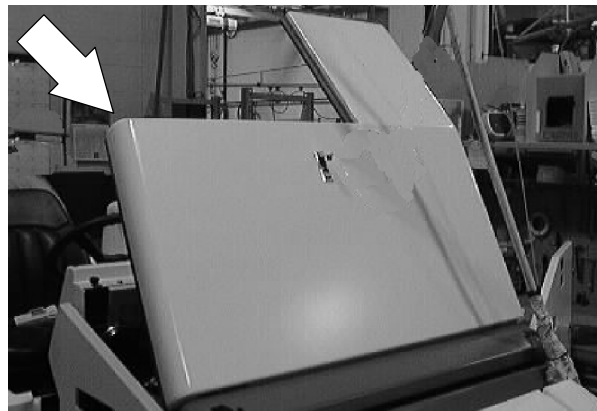

## HYDRAULICS

### TO FILL HYDRAULIC FLUID RESERVOIR

1. Open the engine cover and side door.



2. Remove the reservoir breather-filler cap.

*NOTE: Make sure the hydraulic reservoir drain plug is installed in the bottom of the tank before refilling.*

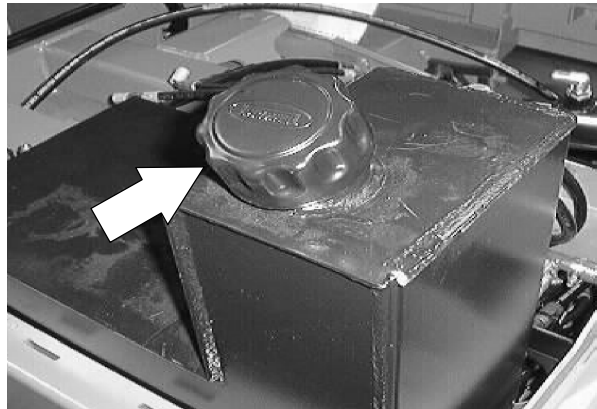

3. Pour new, approved hydraulic fluid through a 200 mesh screened funnel and into the reservoir.

**ATTENTION! Use only new, approved hydraulic fluid to fill the hydraulic fluid reservoir. Do not overfill.**

4. Check the hydraulic fluid level in the reservoir with the fluid level dipstick.
5. Add hydraulic fluid until the level in the reservoir is between the ADD and the FULL range. Do not overfill.

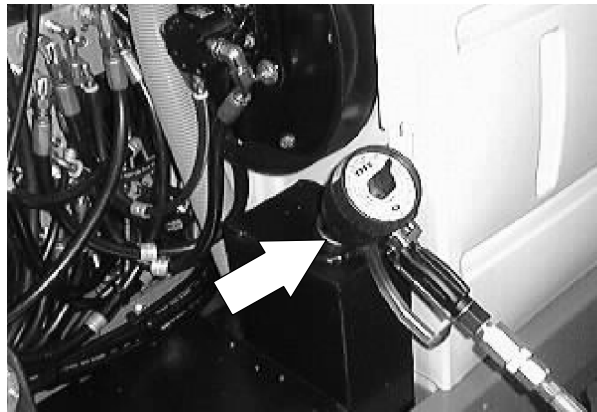

*NOTE: Do not overfill the hydraulic fluid reservoir. Hydraulic fluid expands as it reaches its normal operating temperature. Always allow for expansion when filling the reservoir.*

6. Put the reservoir breather-filler cap on the reservoir.
7. Start engine and operate all the hydraulic components. Re-check the hydraulic fluid level, add fluid if necessary.



---

## HYDRAULIC PUMPS

---

The machine *propelling pump* is a variable displacement hydraulic piston pump. The machine *accessory pumps* are a hydraulic gear type pump.

After repairing or replacing a hydraulic pump, or when system contamination is likely, change the hydraulic fluid in the reservoir and the hydraulic fluid filter.

### TO REPLACE PROPEL PUMP

**FOR SAFETY: Before Leaving Or Servicing Machine; Stop On Level Surface, Set Parking Brake, Turn Off Machine And Remove Key.**

1. Open the engine cover and side door.

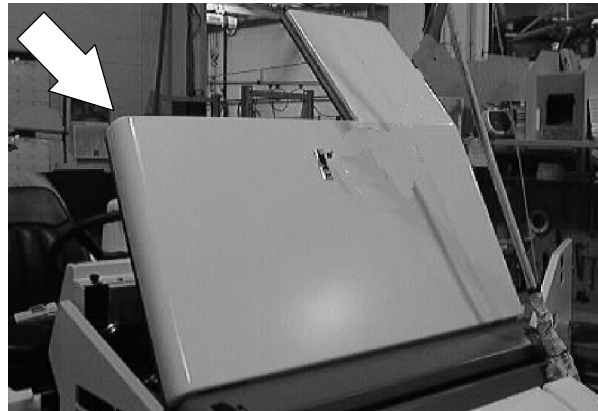

2. Disconnect the battery cables.

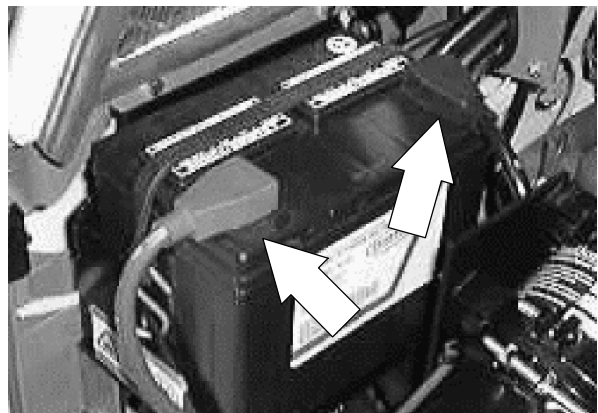

## HYDRAULICS

3. Remove the two hex screws holding the accessory pump and shock absorber bracket to the back of the accessory pump.

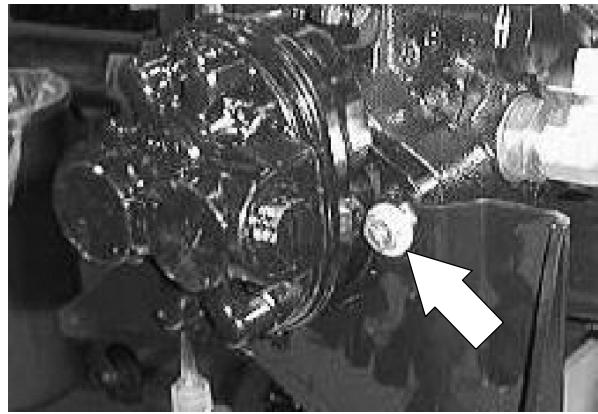

4. Drop the shock absorber bracket down.

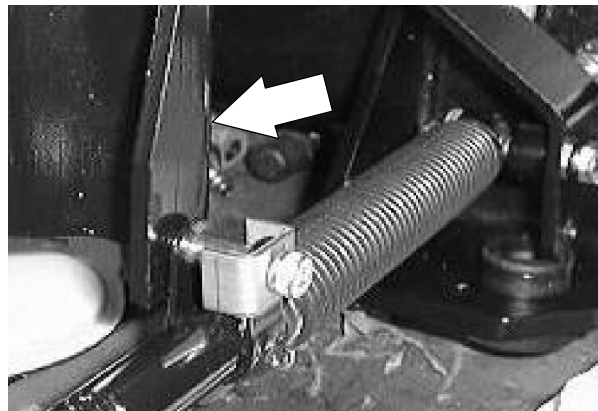

5. Pull the accessory pump out of the propel pump.

*NOTE: Make sure to retain the rubber O-ring and steel spline from between the accessory pump and propel pump.*

*NOTE: Do not disconnect the hydraulic hoses leading to the accessory pump.*

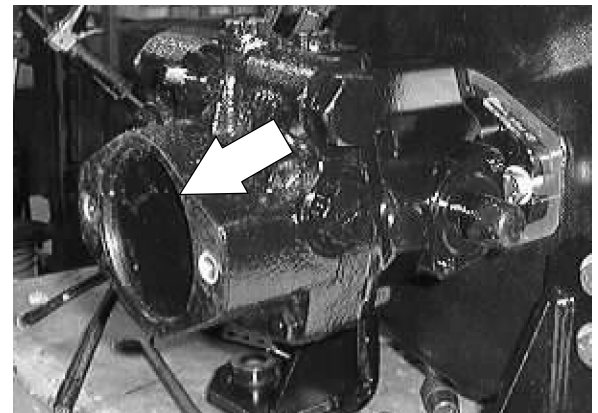

6. Remove the three hex screws holding the directional arm to the propel pump.

*NOTE: Let the arm drop out of the way.*

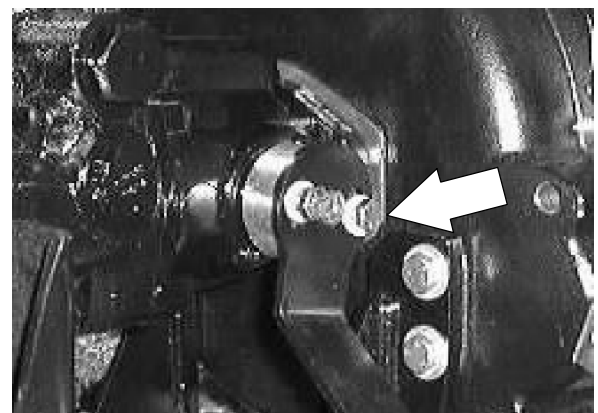

7. Mark, disconnect, and plug the hydraulic hoses leading to the propel pump.

*NOTE: Observe hydraulic cleanliness requirements when opening hydraulic lines.*

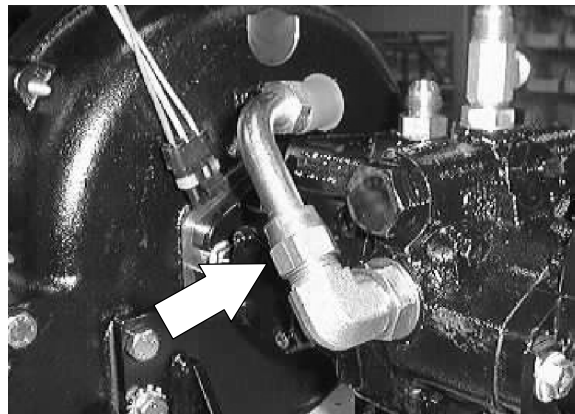

8. Remove the two hex screws holding the propel pump to the bellhousing. Pull the propel pump out of the bellhousing and remove it from the machine.



9. Remove the hydraulic fittings from the old propel pump and install in the new pump in the same orientation.

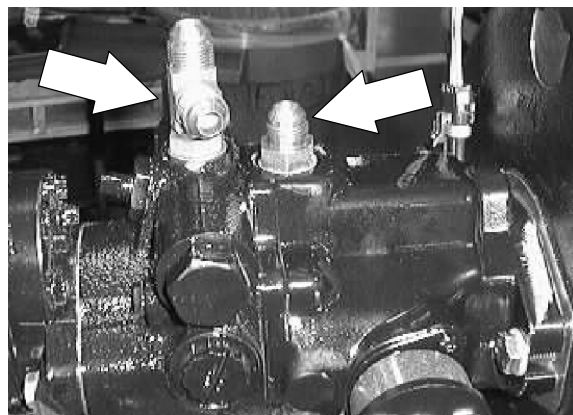

10. Remove the directional arm hub from the old pump and install on the new pump in the same orientation.

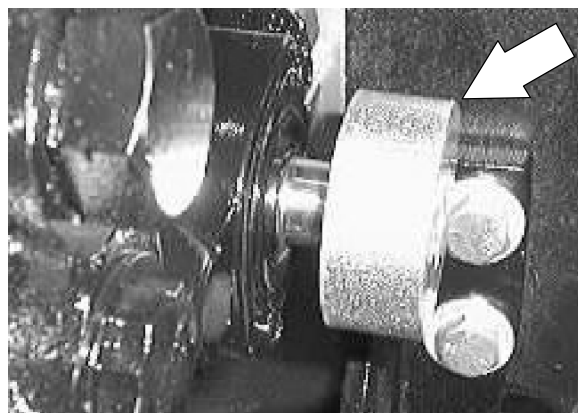

## HYDRAULICS

11. Position the new propel pump in the bellhousing. Reinstall the two hex screws and tighten to 36 - 40 Nm (27 - 30 ft lb). Use loctite 242 blue on the threads.

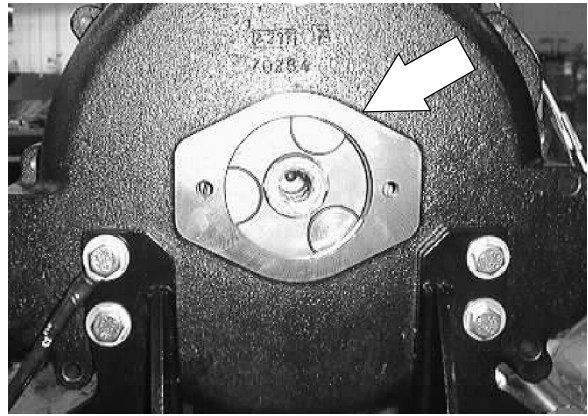

12. Reconnect the hydraulic hoses to the new propel pump. See the hose pictorial in this section.

*NOTE: Observe hydraulic cleanliness requirements when opening hydraulic lines.*

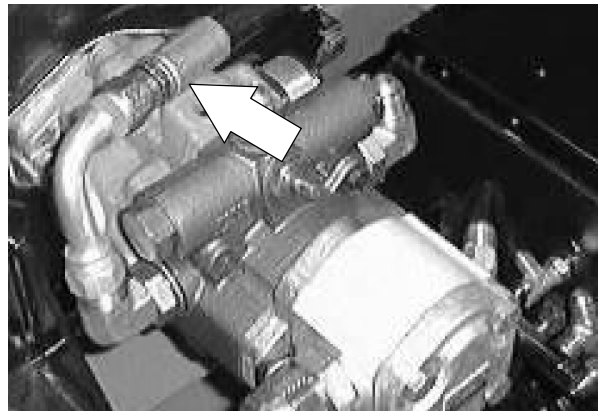

13. Position the accessory pump into the back of the new propel pump.

*NOTE: Make sure the O-ring and steel spline are in place on the accessory pump.*

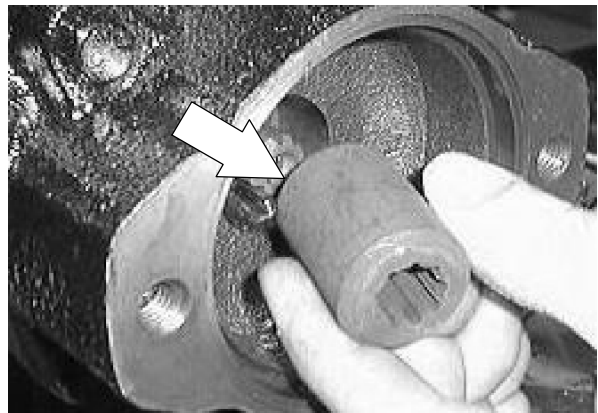

14. Position the shock absorber mount bracket over the mounting flange on the accessory pump. Reinstall the two hex screws and tighten to 36 - 40 Nm (27 - 30 ft lb). Use loctite 242 blue on the threads.

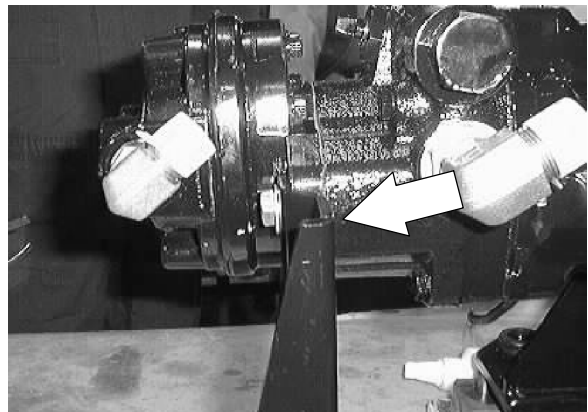

15. Reinstall the directional arm to the propel pump. Leave the three screws loose for now.

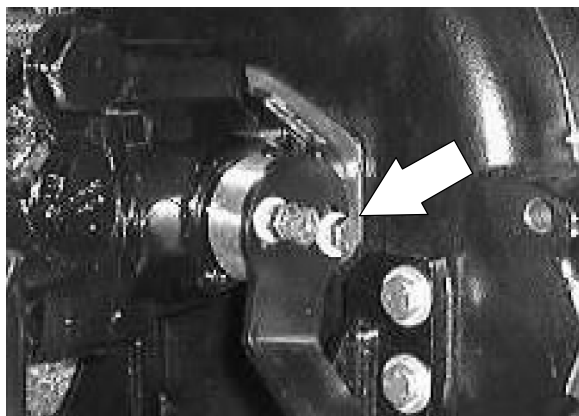

16. Reconnect the battery cables.

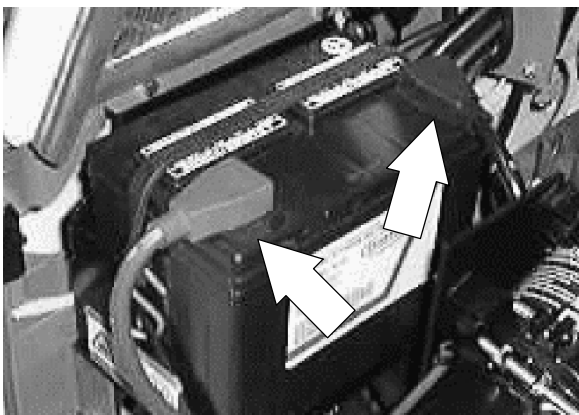

17. Jack up rear of machine. Use jack stands to support machine.

**FOR SAFETY: Block machine tires before jacking machine up. Jack machine up at designated locations only. Block machine up with jack stands.**



18. Adjust the neutral centering of the new propel pump. See TO ADJUST DIRECTIONAL SPRING instructions.

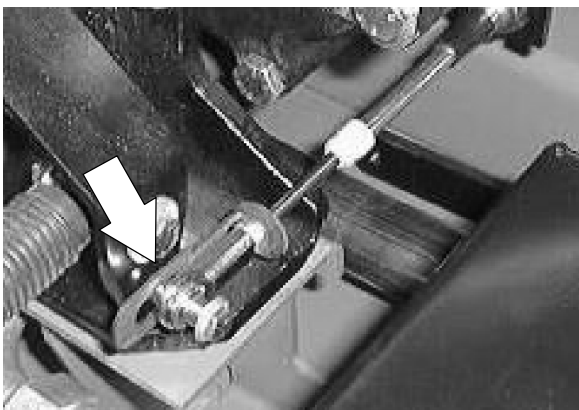

19. Start the machine and check for proper propel operation.

## HYDRAULICS

### TO REPLACE PRIMARY ACCESSORY PUMP

**FOR SAFETY: Before Leaving Or Servicing Machine; Stop On Level Surface, Set Parking Brake, Turn Off Machine And Remove Key.**

1. Open the engine cover and side door.

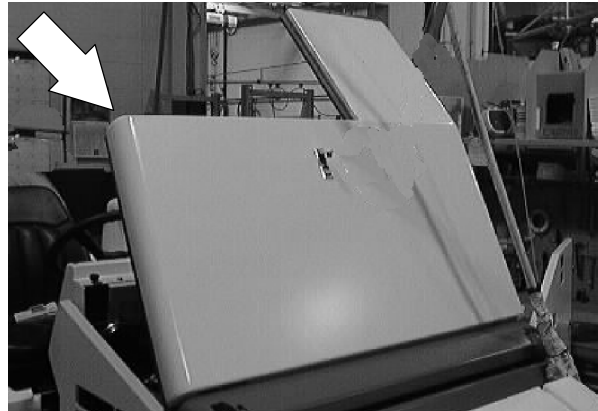

2. Disconnect the battery cables.

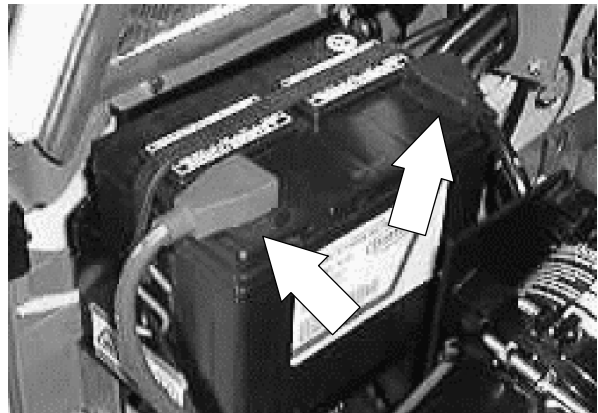

3. Mark, disconnect, and plug the hydraulic hoses leading to the accessory pump.

*NOTE: Observe hydraulic cleanliness requirements when opening hydraulic lines.*

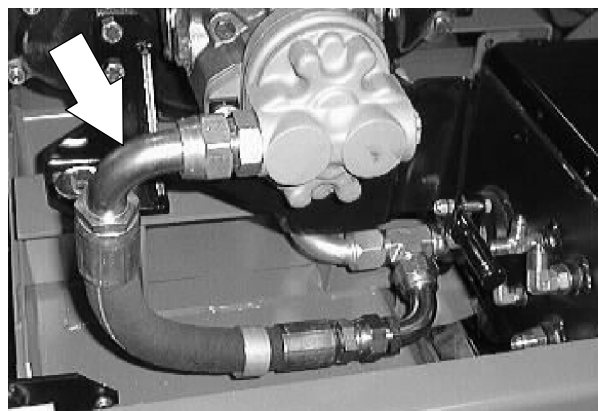



4. Remove the two hex screws holding the accessory pump and shock absorber bracket to the back of the accessory pump.

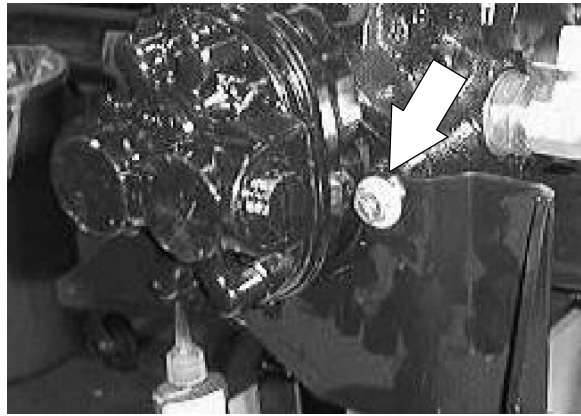

5. Drop the shock absorber bracket down and pull the accessory pump out of the propel pump.

*NOTE: Make sure to retain the rubber O-ring and steel spline from between the accessory pump and propel pump.*

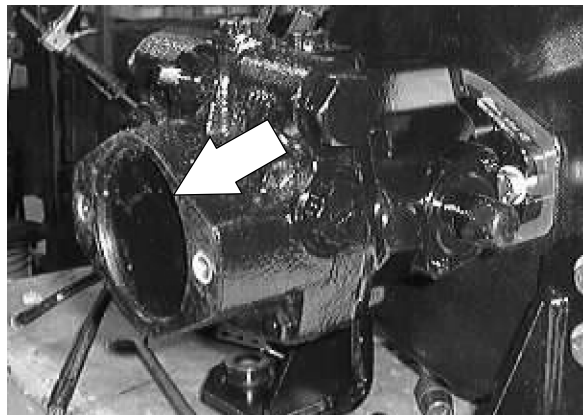

6. Remove the hydraulic fittings from the old accessory pump and install in the new pump in the same orientation.

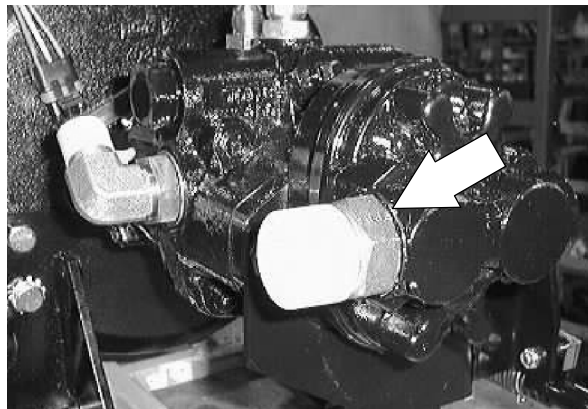

7. Position the new accessory pump in the back of the propel pump.

*NOTE: Make sure the O-ring and steel spline are in place on the accessory pump.*

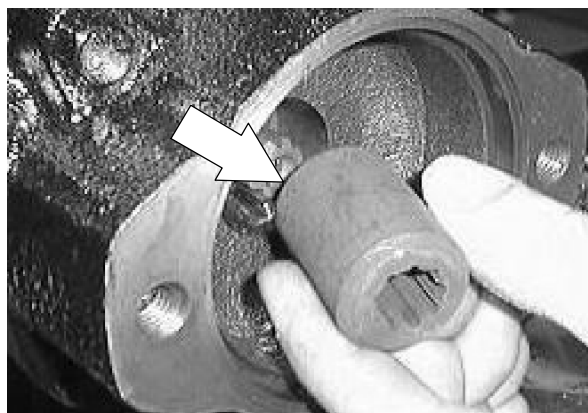

## HYDRAULICS

8. Position the shock absorber mount bracket over the mounting flange on the accessory pump. Reinstall the two hex screws and tighten to 36 - 40 Nm (27 - 30 ft lb). Use loctite 242 blue on the threads.

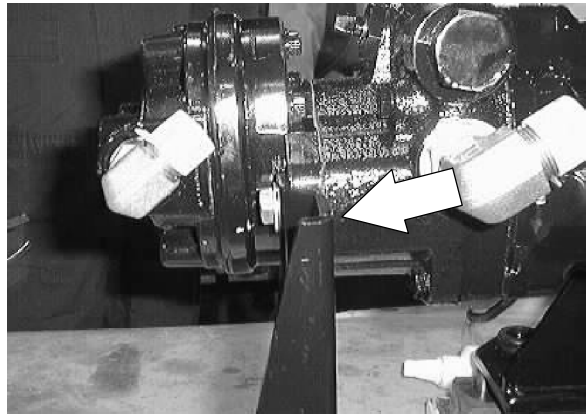

9. Reconnect the hydraulic hoses to the new accessory pump.

*NOTE: Observe hydraulic cleanliness requirements when opening hydraulic lines.*

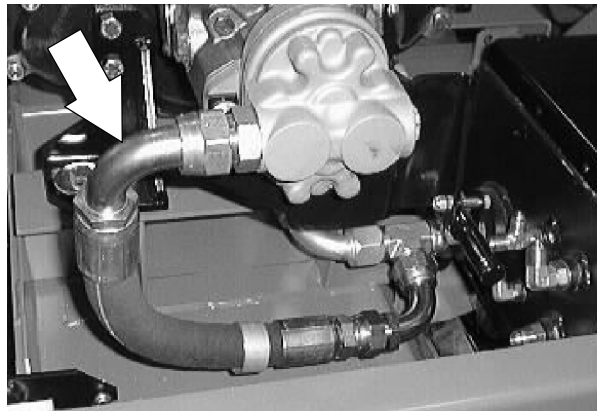

10. Reconnect the battery cables.

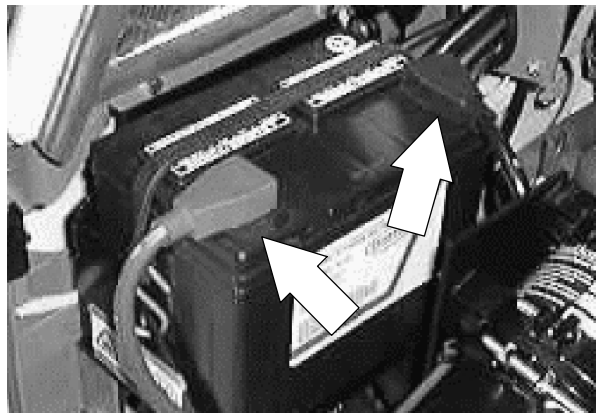

11. Raise the rear of the machine. Place jack stands under the frame.

**FOR SAFETY: Block machine tires before jacking machine up. Jack machine up at designated locations only. Block machine up with jack stands.**

12. Start the machine and check for proper operation. See TO ADJUST DIRECTIONAL SPRING instructions if needed.



**TO REPLACE BELT DRIVEN ACCESSORY PUMP**

1. Empty the debris hopper.

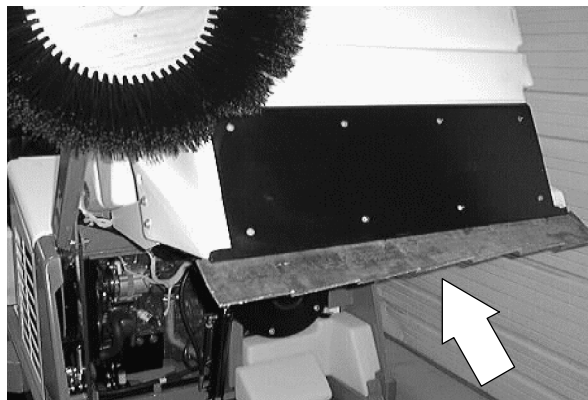

2. Set the machine parking brake.

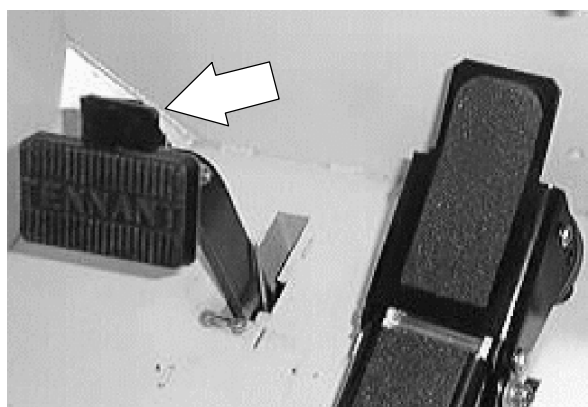

3. Raise the hopper and engage the prop arm. Shut off the engine.

**⚠ WARNING: Raised Hopper May Fall. Engage Hopper Support Bar.**

**FOR SAFETY: Before Leaving Or Servicing Machine; Stop On Level Surface, Set Parking Brake, Turn Off Machine And Remove Key.**

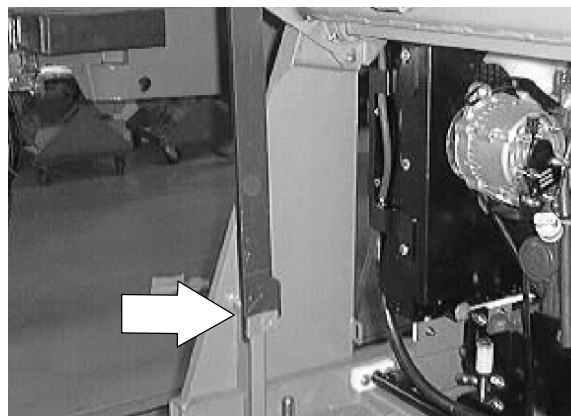

## HYDRAULICS

4. Pull the rubber dust shield out of the metal bracket. Pull the dust shield back for access to the accessory pump.



5. Open the engine cover and side door.



6. Disconnect the battery cables.

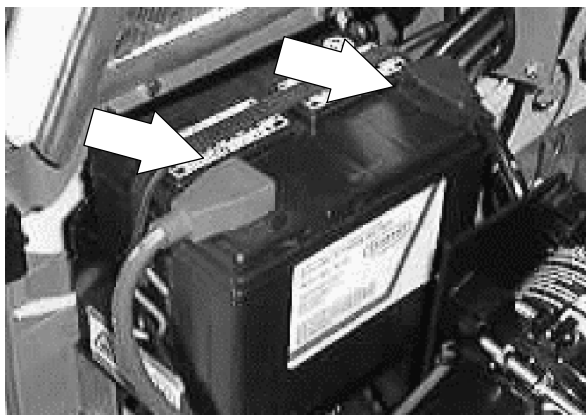

7. Remove the two screws holding the radiator guard to the machine. Remove the guard.

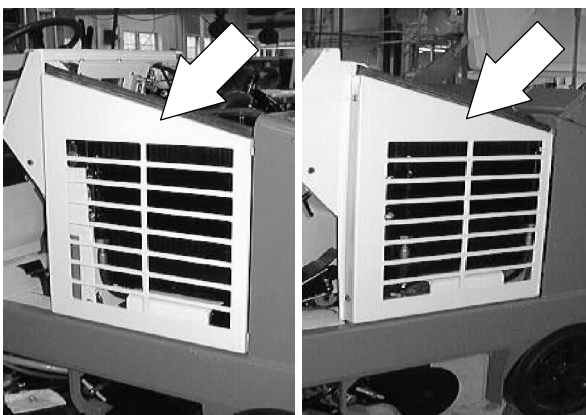

- Remove the four screws holding the hydraulic oil cooler to the radiator. Pull the cooler away from the radiator.

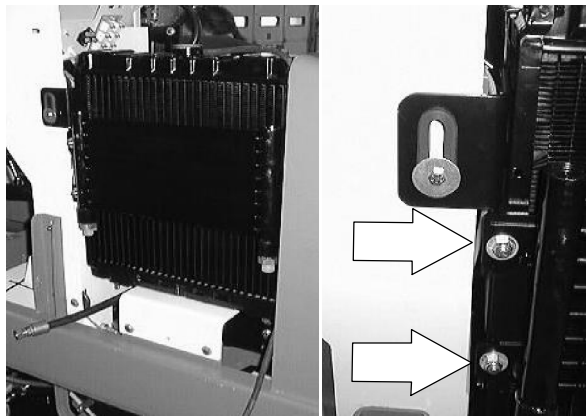

- Drain the engine coolant.

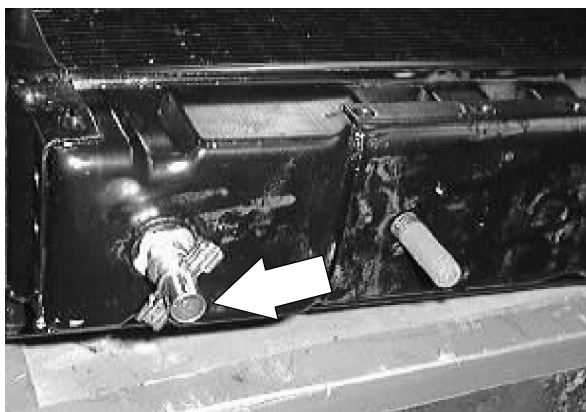

- Disconnect the upper and lower radiator hoses.

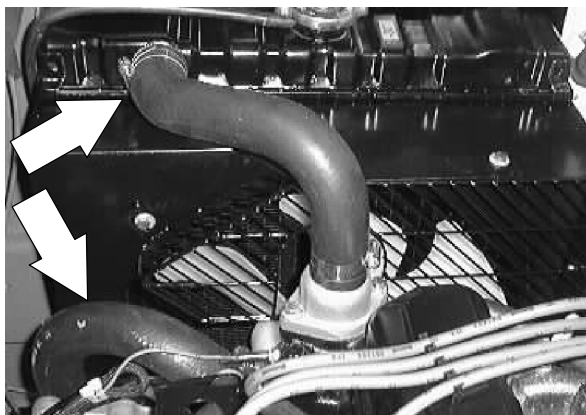

- Remove the two hex nuts holding the bottom of the radiator to the mount bracket.

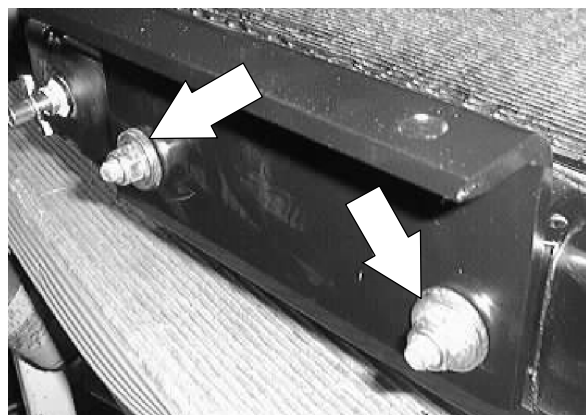

## HYDRAULICS

12. Remove the hex screw holding the top of the radiator to the operator compartment.  
Remove the radiator from the machine.

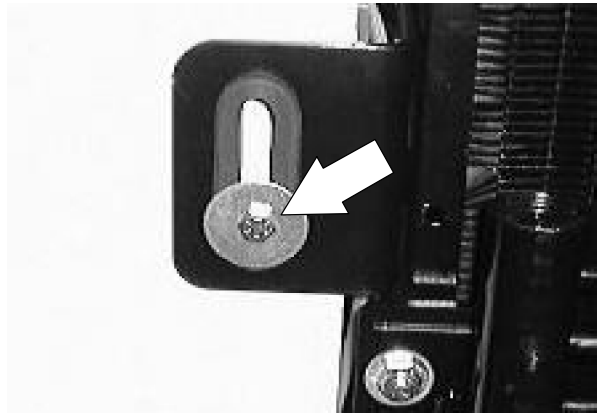

13. Mark, disconnect, and plug the hydraulic hoses leading to the accessory pump.

*NOTE: Observe hydraulic cleanliness requirements when opening hydraulic lines.*

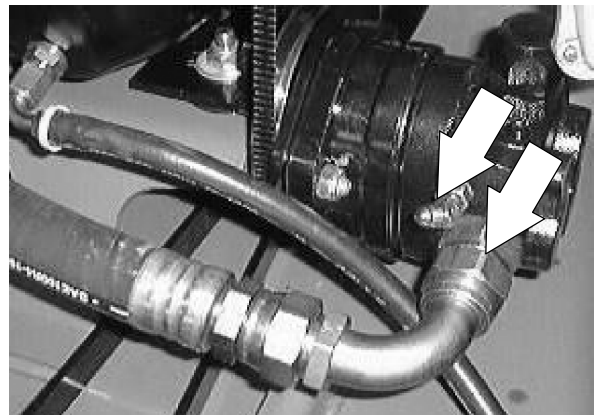

14. Go to the front the machine and locate the two hex screws and nuts holding the accessory pump pivot plate to the mount plate. Loosen these two screws.

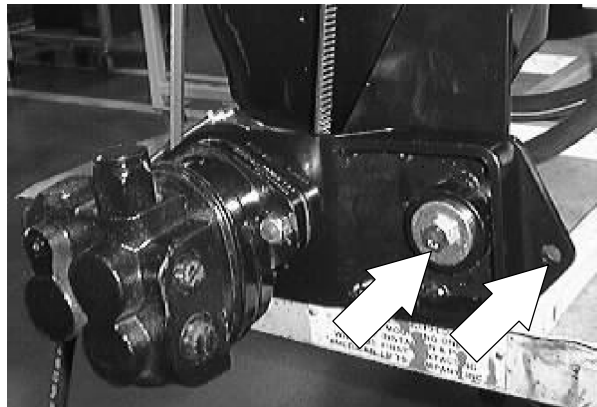

15. Locate the hex bolt and compression spring at the front of the accessory pump mount bracket. Remove the hex bolt and compression spring. Push the pump up to remove the V-belt from the pump sheave.



16. Remove the two hex screws and nuts holding the accessory pump pivot plate to the mount plate. Remove the pump and pivot plate from the machine.

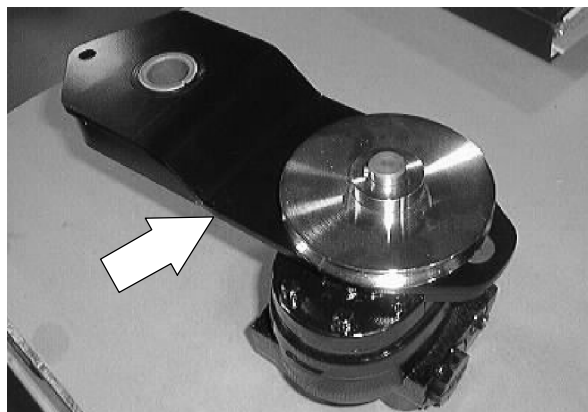

17. Loosen the set screws holding the sheave to the pump shaft. Remove the sheave from the pump.

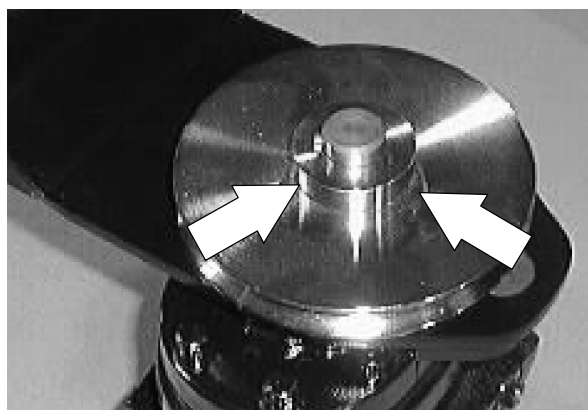

18. Remove the two flat screws and nyloc nuts holding the pump to the pivot plate. Remove the pump from the plate.

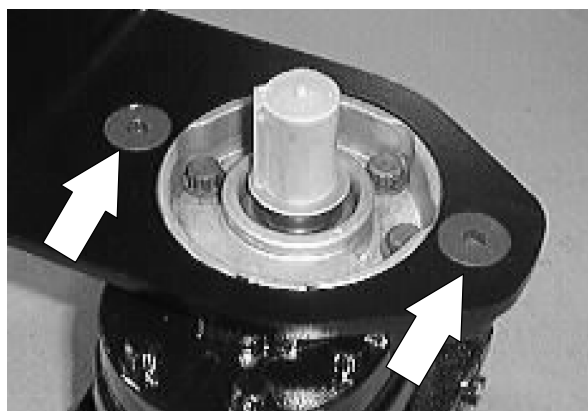

19. Remove the hydraulic fittings from the old accessory pump and install in the new pump in the same orientation.

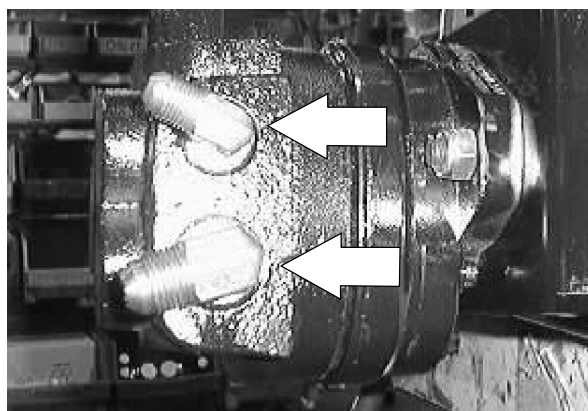

## HYDRAULICS

20. Install the new pump and fittings on the pivot bracket. Tighten the nyloc nuts to 37 - 48 Nm (26 - 34 ft lb).

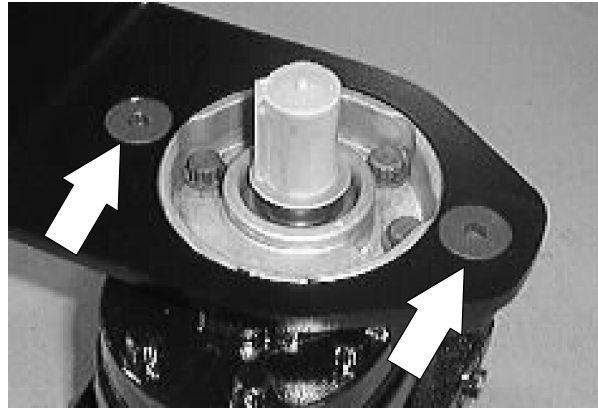

21. Install the V-belt sheave on the shaft of the new pump. Leave the set screws loose for now.

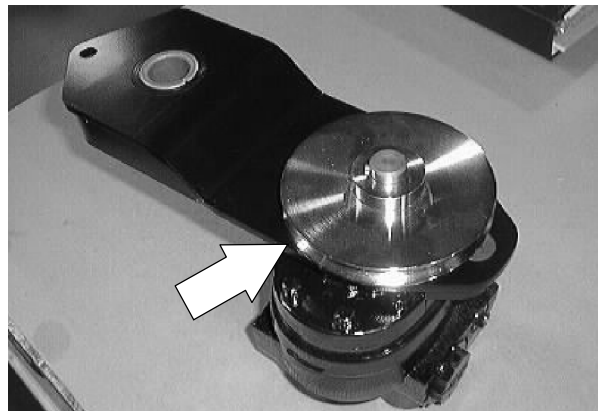

22. Install the pump and pivot bracket assembly onto the mount bracket. Install the two screws and nuts. Leave loose for now.

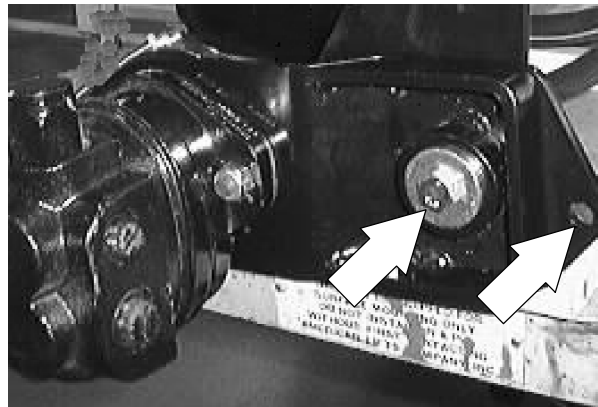

23. Install the compression spring and long hex screw in the front adjustment hole in the mount bracket and pivot bracket.

*NOTE: Be sure to put blue loctite on the threads of the hex screw.*

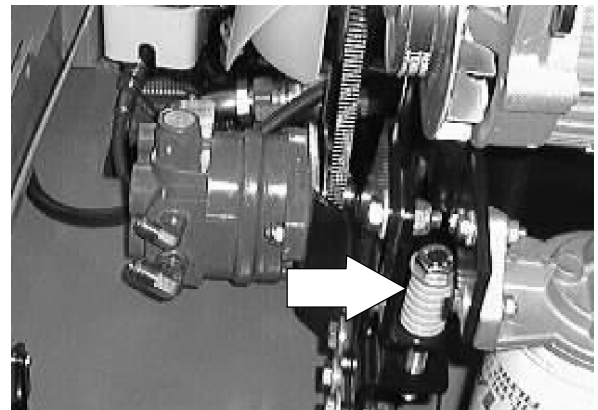



24. Install the V-belt around the accessory pump sheave.

*NOTE: Use a straight edge to align the pump sheave and engine sheave within .020 inch runout for proper belt tracking.*

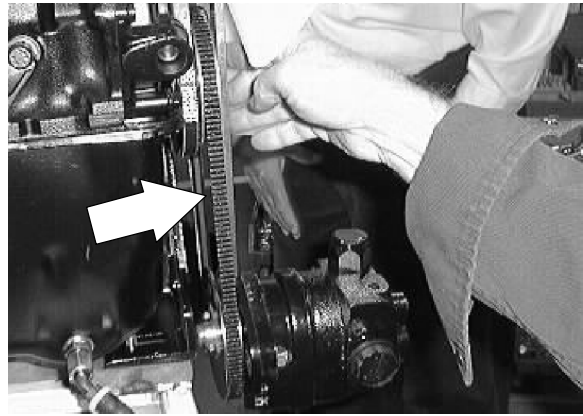

25. The accessory pump belt adjustment is made by turning the bolt on top of the tension spring. The tension spring is located at the front of the engine compartment, near the accessory pump belt sheave. The accessory pump belt is at the proper tension when the tension spring is compressed to 3.81 cm ± 0.0076 mm (1.5 in ± 0.030 in).

*NOTE: When adjusting the accessory pump belt tension, measure only the spring and not the washers at either end.*

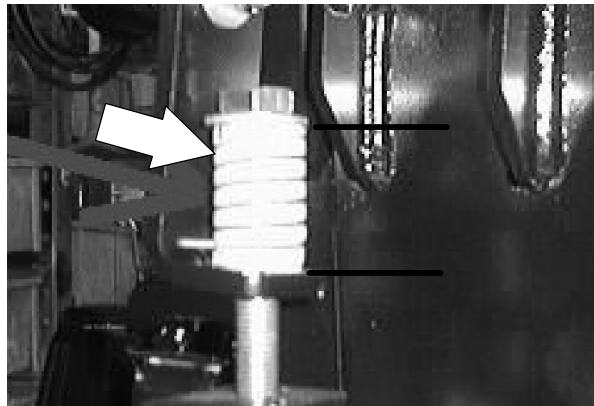

26. Put blue loctite on the threads of the two pump sheave set screws. Install and tighten securely.

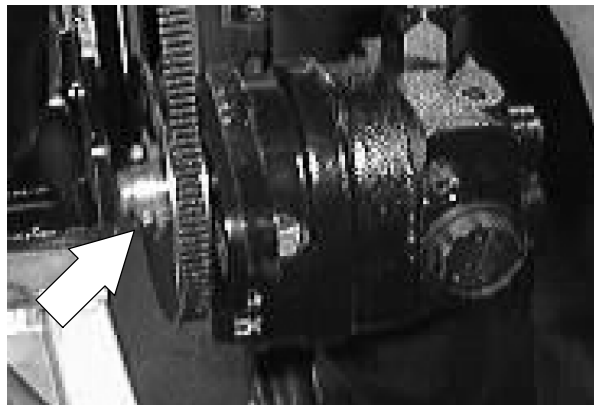

27. Go back and tighten the two pivot plate mount screws to 37 - 48 Nm (26 - 34 ft lb).

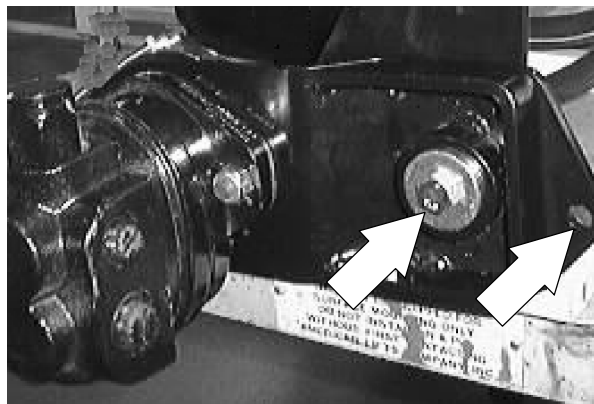

## HYDRAULICS

28. Reconnect the hydraulic hoses to the new accessory pump. See hose diagram in this section.

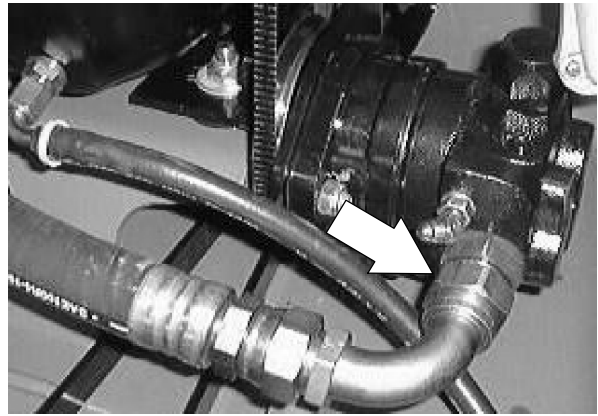

29. Position the radiator into the machine. Reinstall the two nuts under the radiator mount bracket.

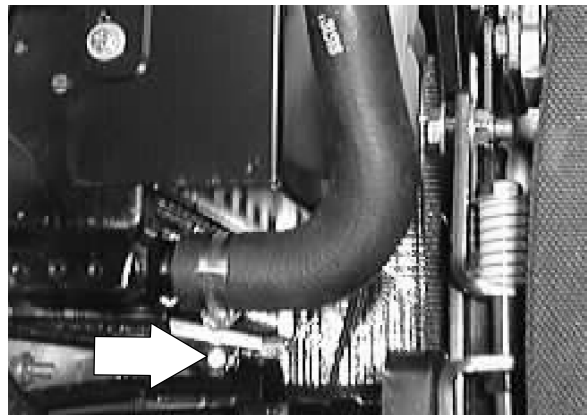

30. Reinstall the hex screw and washer into the top of the radiator.

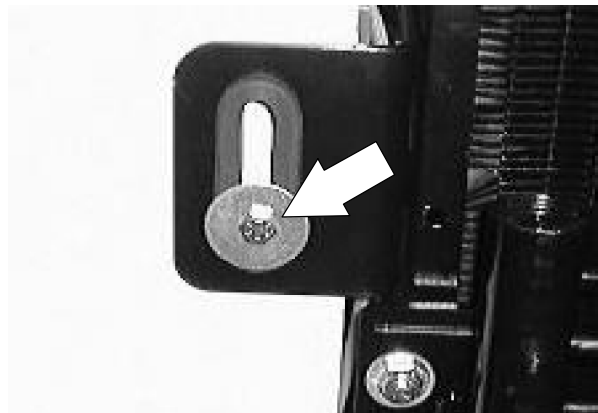

31. Reconnect the top and bottom radiator hoses.

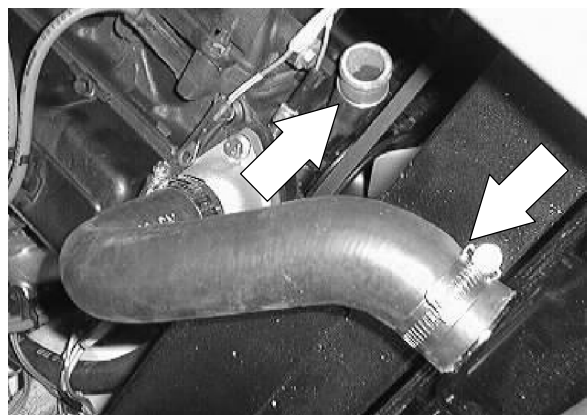

32. Position the hydraulic cooler onto the front of the radiator. Reinstall the four screws and tighten to 18 - 24 Nm(15 - 20 ft lb).

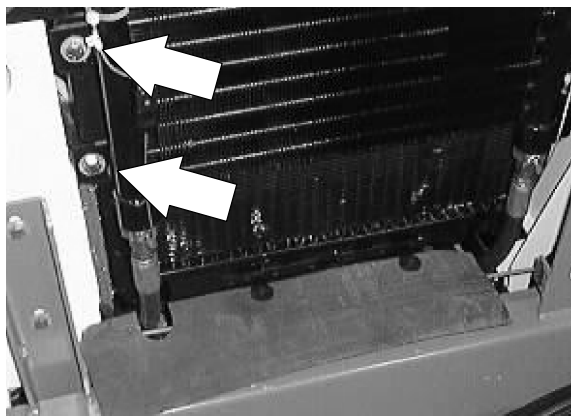

33. Refill the radiator with coolant.

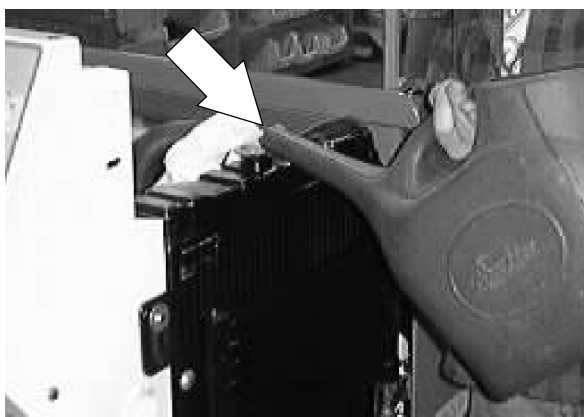

34. Reinstall the radiator grill and two mounting screws. Tighten to 18 - 24 Nm(15 - 20 ft lb).

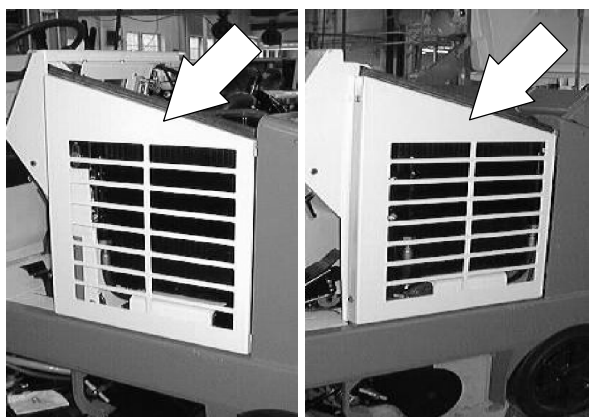

35. Position the rubber dust shield back into the metal bracket.

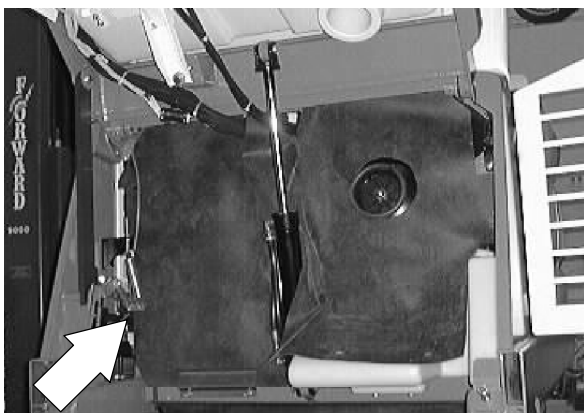

## HYDRAULICS

36. Reconnect the battery and start the machine.

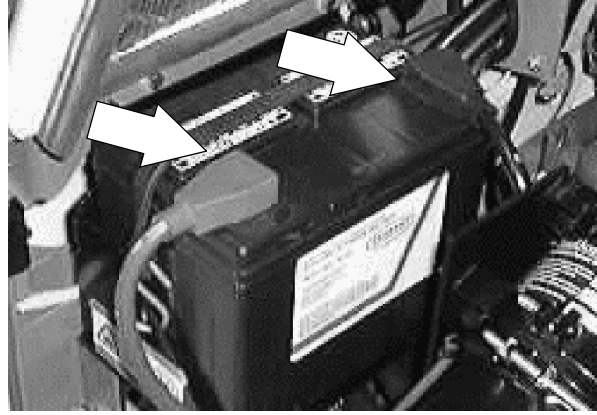

37. Disengage the prop arm and lower the hopper.



38. Check the machine for proper operation.  
Check for hydraulic leaks at the accessory pump.

**TO REPLACE BELT DRIVEN ACCESSORY PUMP V-BELT**

1. Empty the debris hopper.

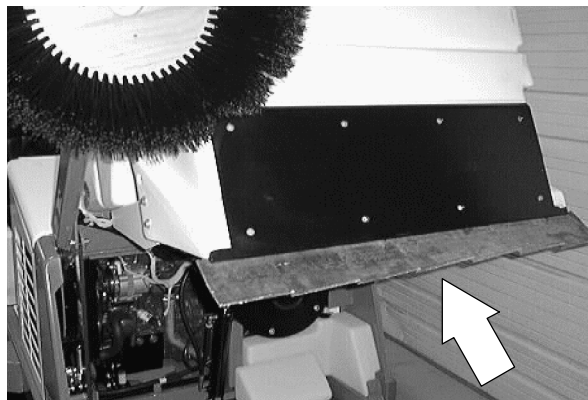

2. Set the machine parking brake.

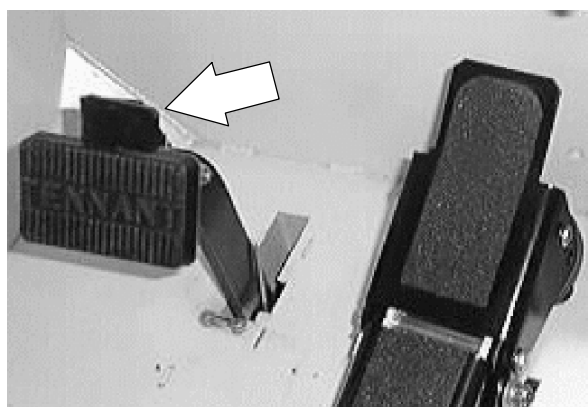

3. Raise the hopper and engage the prop arm. Shut off the engine.

**⚠ WARNING: Raised Hopper May Fall. Engage Hopper Support Bar.**

**FOR SAFETY: Before Leaving Or Servicing Machine; Stop On Level Surface, Set Parking Brake, Turn Off Machine And Remove Key.**

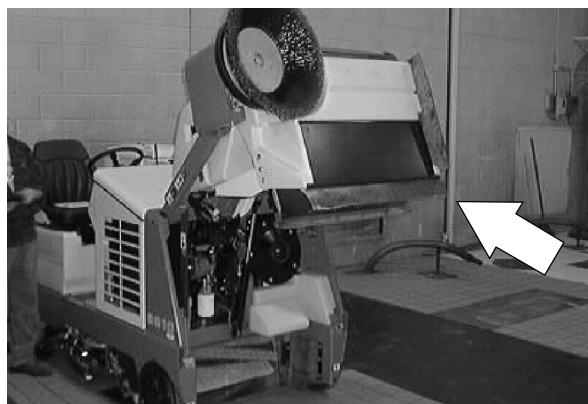

## HYDRAULICS

4. Pull the rubber dust shield out of the metal bracket. Pull the dust shield back for access to the accessory pump.

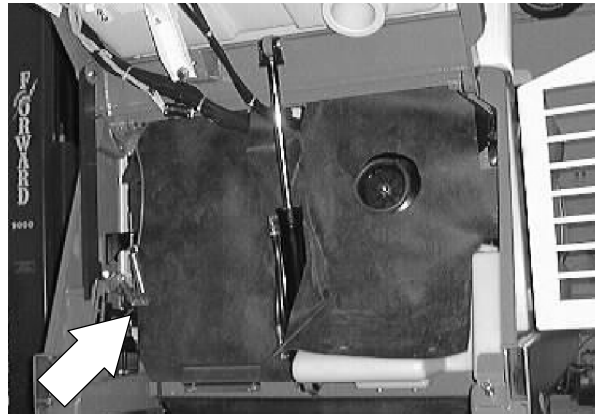

5. Open the engine cover and side door.



6. Disconnect the battery cables.

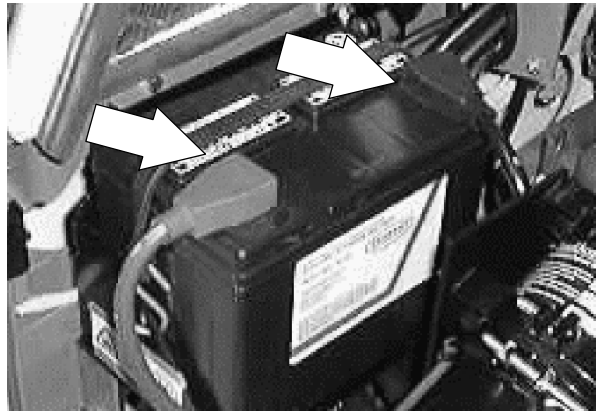

7. Go to the front the machine and locate the two hex screws and nuts holding the accessory pump pivot plate to the mount plate. Loosen these two screws.

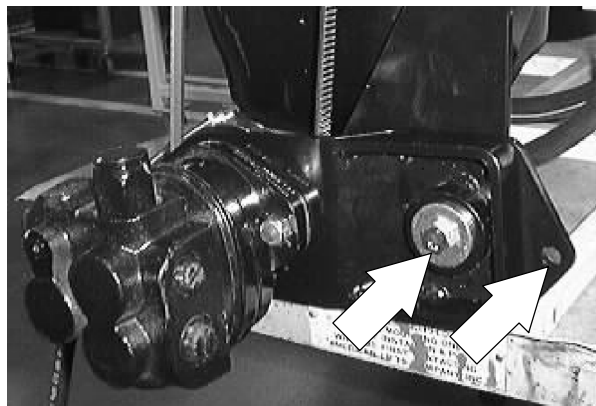

8. Locate the hex bolt and compression spring at the front of the accessory pump mount bracket. Remove the hex bolt and compression spring. Push the pump up to remove the V-belt from the pump sheave.

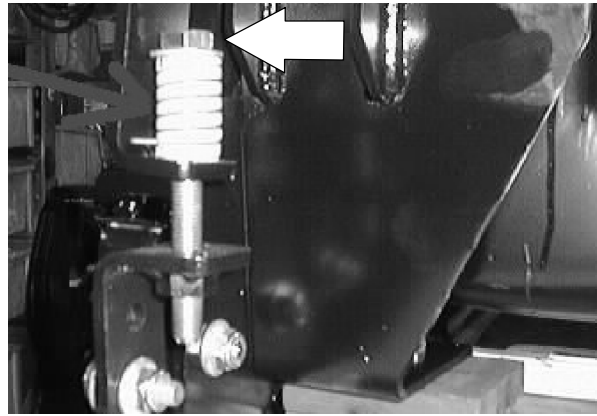

9. Install the V-belt around the accessory pump sheave.

*NOTE: Use a straight edge to align the pump sheave and engine sheave within .020 inch runout for proper belt tracking.*

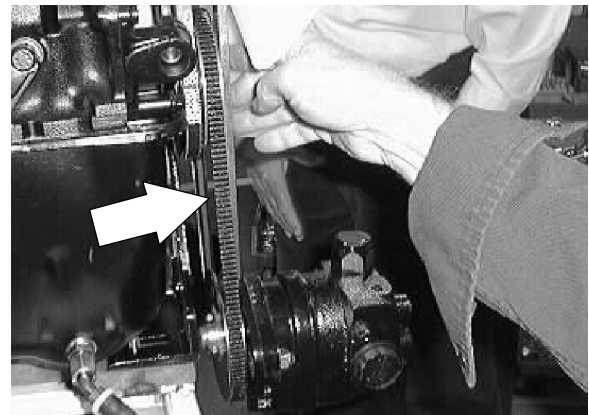

10. The accessory pump belt adjustment is made by turning the bolt on top of the tension spring. The tension spring is located at the front of the engine compartment, near the accessory pump belt sheave. The accessory pump belt is at the proper tension when the tension spring is compressed to 3.81 cm ± 0.0076 mm (1.5 in ± 0.030 in).

*NOTE: When adjusting the accessory pump belt tension, measure only the spring and not the washers at either end.*

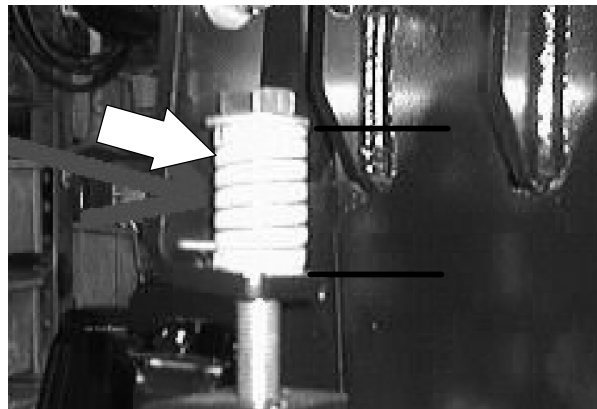

11. Go back and tighten the two pivot plate mount screws to 37 - 48 Nm (26 - 34 ft lb).

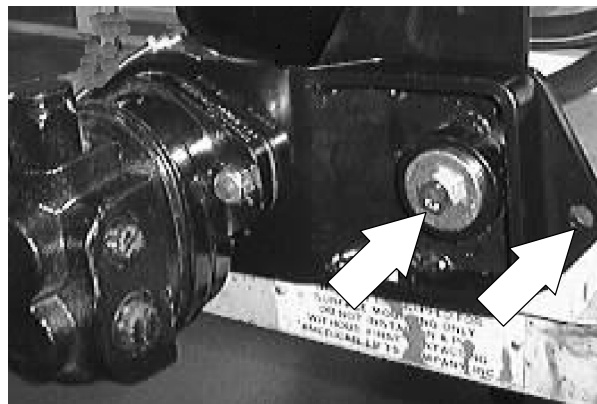

## HYDRAULICS

12. Position the rubber dust shield back into the metal bracket.

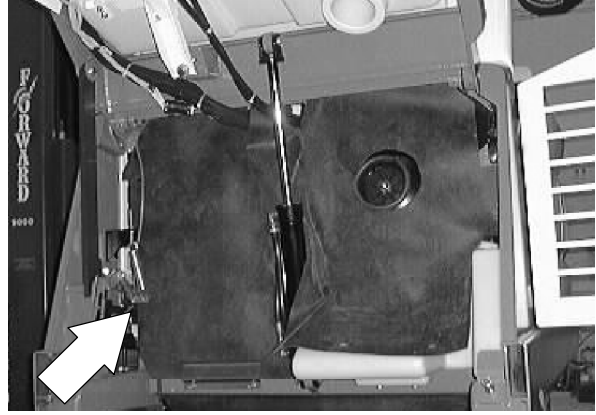

13. Reconnect the battery and start the machine.

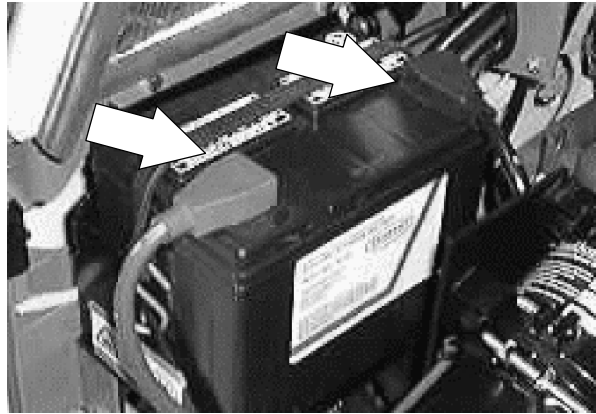

14. Disengage the prop arm and lower the hopper.



15. Check the machine for proper operation.



## DIRECTIONAL PEDAL

The directional pedal controls the flow of hydraulic fluid to the hydraulic propelling motor.

The pedal neutral position is the position in which the propelling pump sends no hydraulic fluid to the propelling motor. The machine should not move when the pedal neutral position is adjusted correctly. The pedal linkages should also be adjusted whenever the reverse is faster or slower than machine specification.

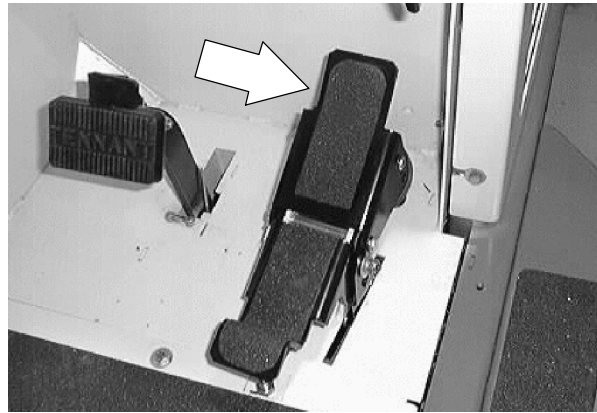

## TO REPLACE PROPEL DIRECTIONAL SPRING

1. Start the machine and lower the scrub head. Turn off the machine.

**FOR SAFETY: Before Leaving Or Servicing Machine; Stop On Level Surface, Set Parking Brake, Turn Off Machine And Remove Key.**

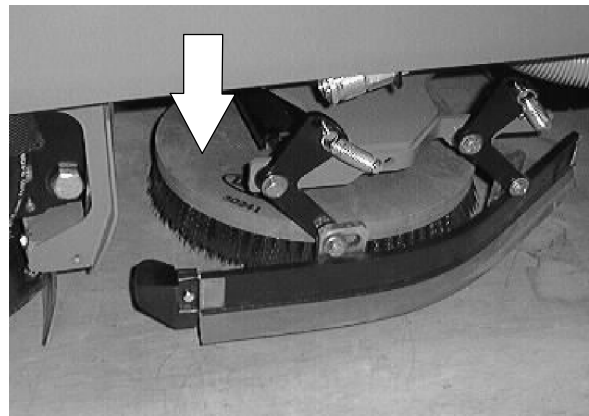

2. Remove the floor mat from the operators compartment. Remove the three screws holding the floor plate in the operator compartment. Remove the floor plate.

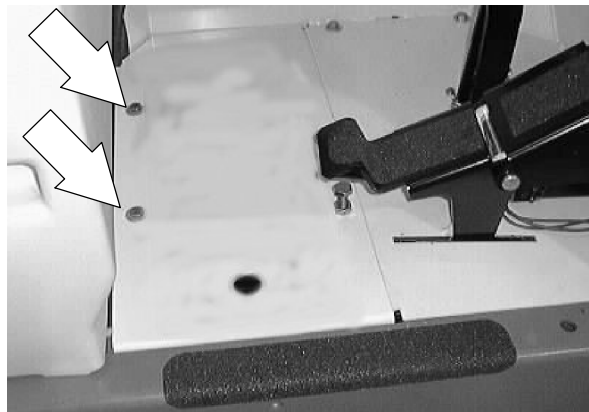

## HYDRAULICS

3. Remove the two screws holding the radiator grill guard to the machine. Pull the grill out of the rubber grommets and remove it from the machine.

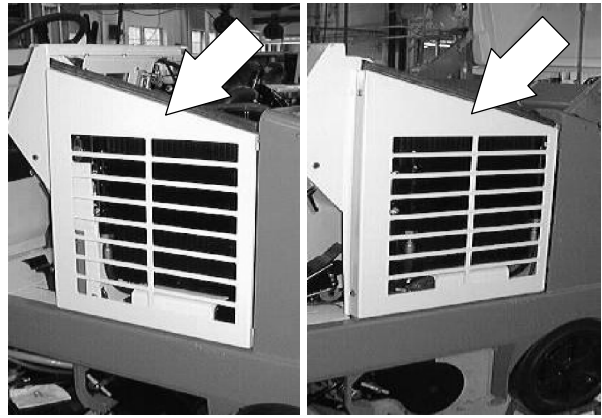

4. Go in under the operator compartment, above the scrub head. Locate the directional spring ball joint end on the direction pedal. Remove the nut from the ball joint end. Pull the ball end out of the pedal.

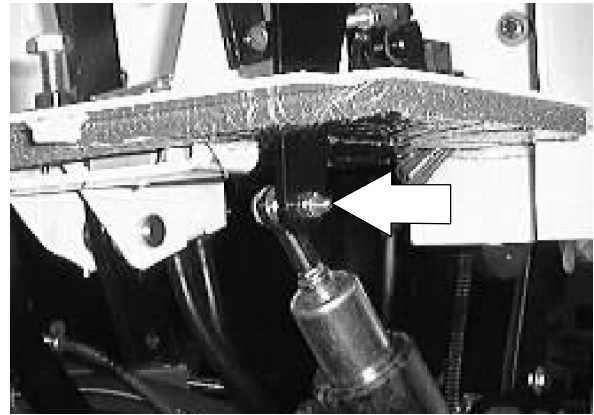

5. Loosen the jam nut on the directional cable. Remove the ball joint and jam nut from the cable.

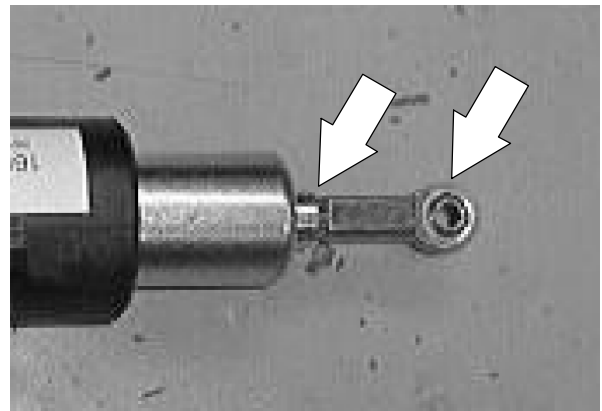

6. Loosen the two large jam nuts holding the directional spring assembly to the frame. Drop the spring down out of the mount slot.

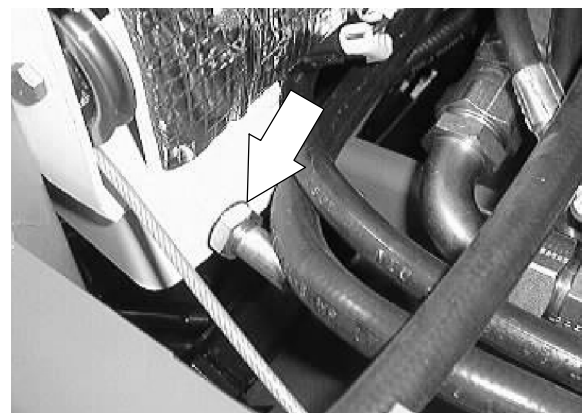

- Un-screw the directional spring assembly from the directional cable. Remove the spring assembly from the machine.

*NOTE: Mark the directional cable before removing the directional spring to make sure the new spring is install in the same location.*

- Install the new directional spring on the old directional cable. Position the new spring in the same location on the cable as the old one.
- Place the new directional spring in the mount slot. Tighten the large jam nut firmly.

- Reinstall the jam nut and ball joint onto the directional cable in the same location as it was removed. Tighten the jam nut against the ball joint.

- Reinstall the ball joint into the mount hole in the directional pedal. Tighten the nyloc nut tight.

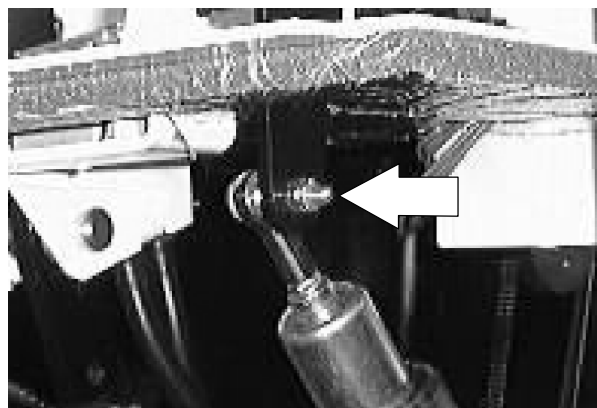
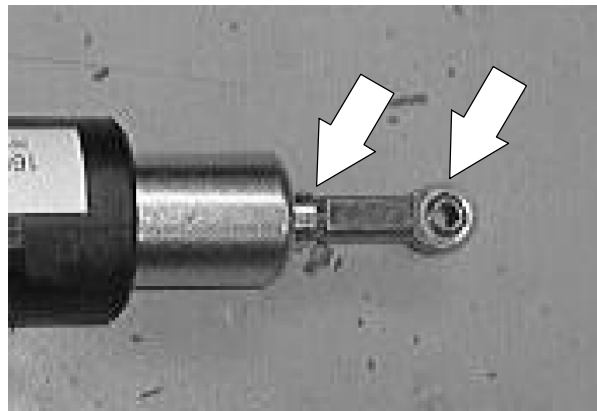
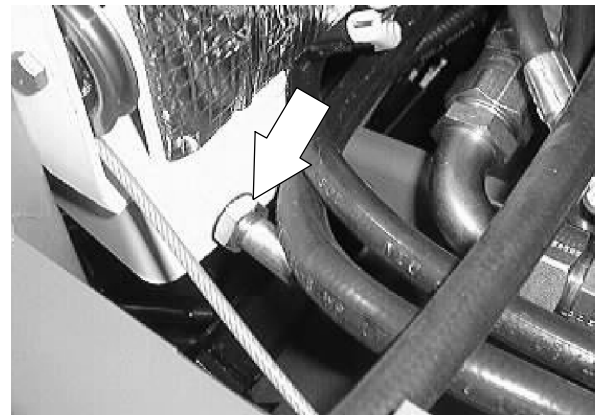

## HYDRAULICS

12. Reinstall the radiator grill guard and two mounting screws. Tighten to 18 - 24 Nm (15 - 20 ft lb).



13. Reinstall the floor plate and three mounting screws. Tighten to 18 - 24 Nm (15 - 20 ft lb). Reinstall the floor mat.

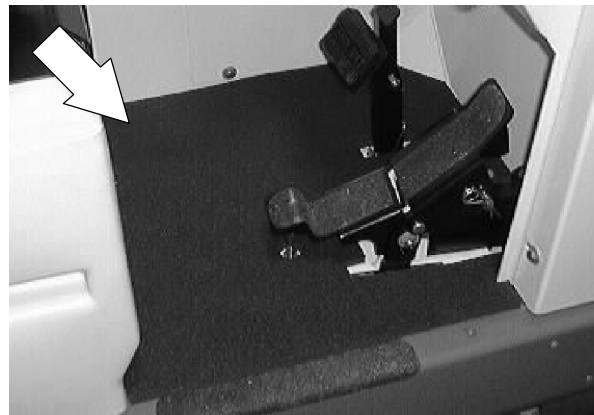

14. Raise the rear of the machine and install jack stands under the frame.

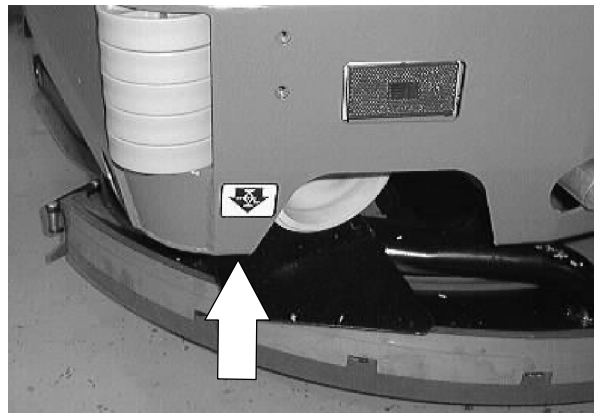

15. Start the machine and raise the scrub head. Check the rear drive wheel for any rotation. Adjust if necessary. See TO ADJUST NEUTRAL CENTERING instructions.

16. Remove the jack stands and lower the machine.

17. Operate the machine and check the propel centering for proper operation.

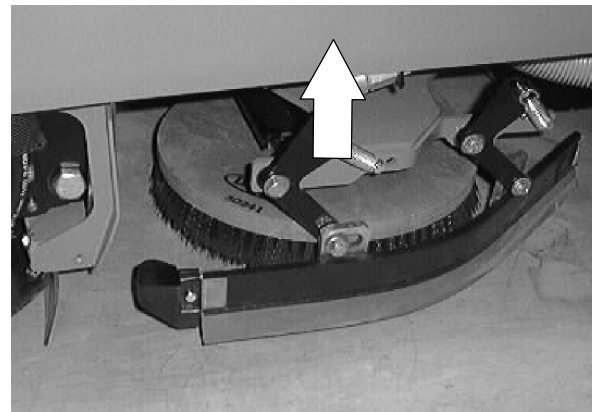

**TO REPLACE PROPEL DIRECTIONAL CABLE**

1. Start the machine and lower the scrub head. Turn off the machine.

**FOR SAFETY: Before Leaving Or Servicing Machine; Stop On Level Surface, Set Parking Brake, Turn Off Machine And Remove Key.**

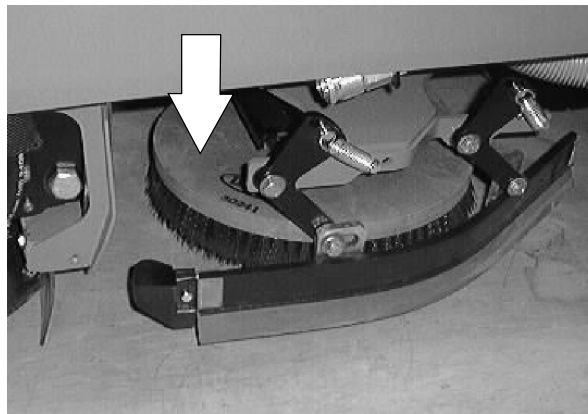

2. Remove the floor mat from the operators compartment. Remove the three screws holding the floor plate in the operator compartment. Remove the floor plate.

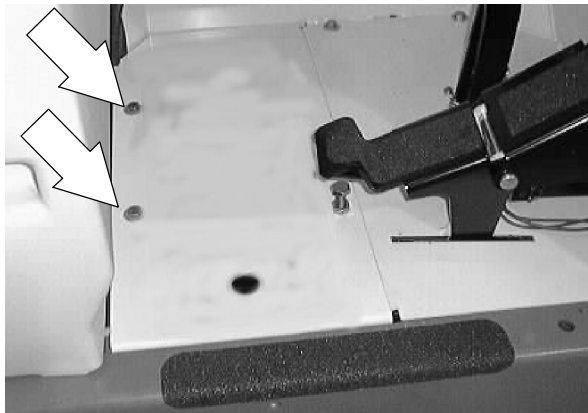

3. Remove the two screws holding the radiator grill guard to the machine. Pull the grill out of the rubber grommets and remove it from the machine.

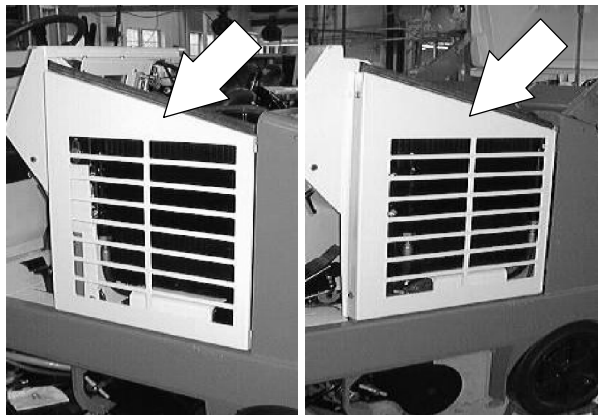

4. Go in under the operator compartment, above the scrub head. Locate the directional spring ball joint end on the direction pedal. Remove the nut from the ball joint end. Pull the ball end out of the pedal.

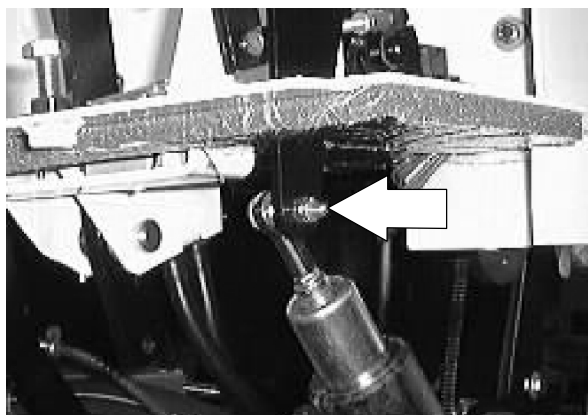

## HYDRAULICS

5. Loosen the jam nut on the directional cable. Remove the ball joint and jam nut from the cable.

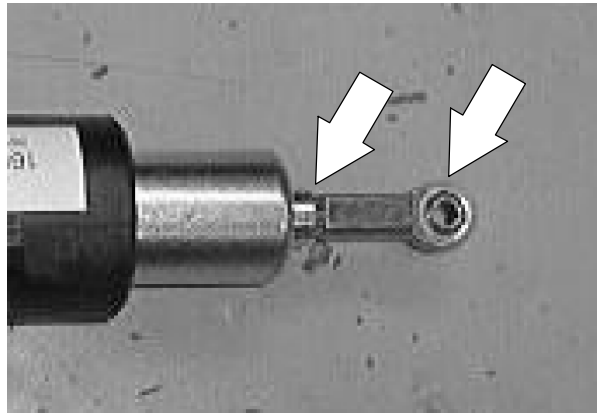

6. Loosen the two large jam nuts holding the directional spring assembly to the frame. Drop the spring down out of the mount slot.

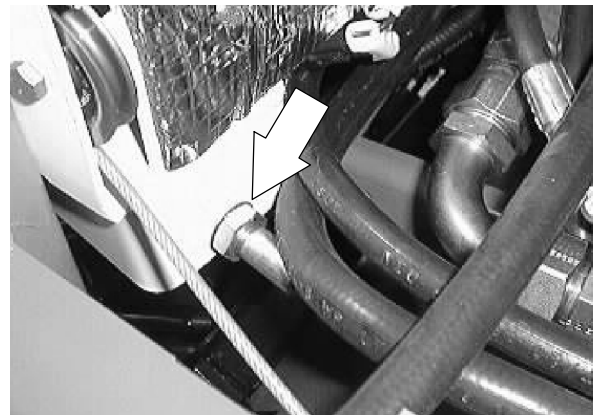

7. Un-screw the directional spring assembly from the directional cable. Remove the spring assembly from the machine.

*NOTE: Mark the directional cable before removing the directional spring to make sure the new spring is install in the same location.*

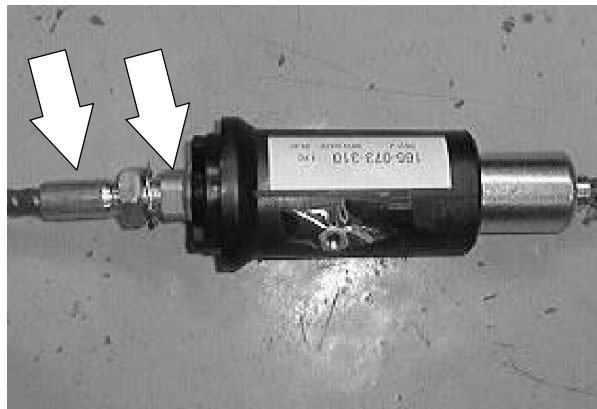

8. Open the engine side door.



9. Locate the other end of the directional cable at the propel pump.

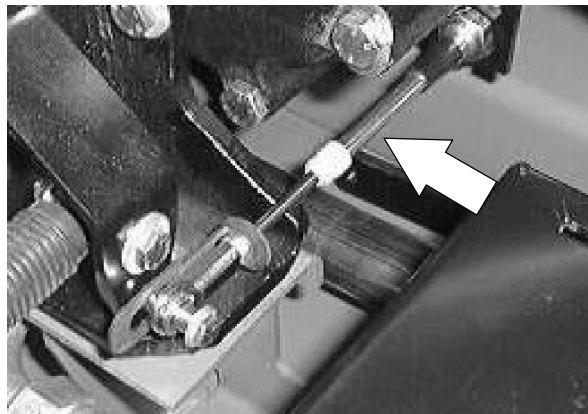

10. Remove the hex screw, spacer, and nyloc nut holding the directional spring ball end to the propel pump arm.

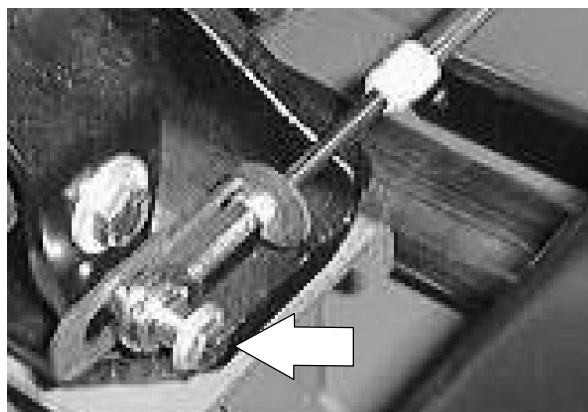

11. Cut the plastic tie from around the propel cable bracket.

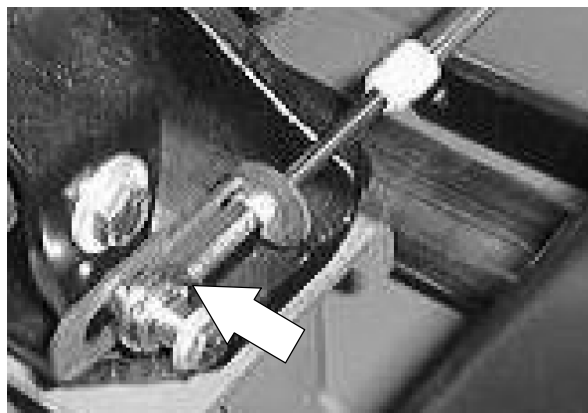

12. Remove the ball end, 1st jam nut, washer, propel cable bracket, and 2nd jam nut from the end of the directional cable.

*NOTE: Make note of the location of the 2nd jam nut for proper re-assembly.*

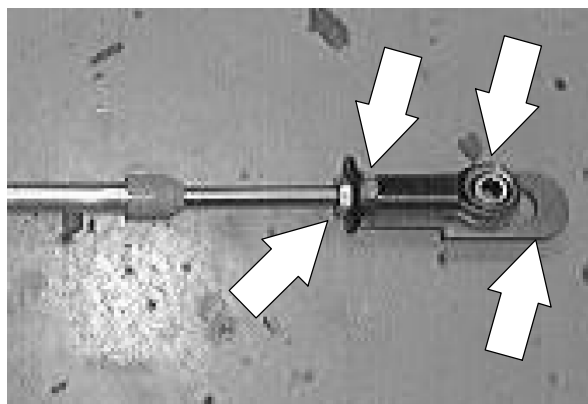

## HYDRAULICS

- Loosen the two large jam nuts holding the directional spring assembly to the lower mount bracket. Drop the cable down and out of the mount slot.
- Remove the old directional cable from the machine. Carefully route the new directional cable in the machine. Follow the same path as the old cable.

*NOTE: One end of the new cable has 1 inch of thread and the other end has 1-1/2 inch of thread. The end with 1-1/2 inch of thread goes toward the directional pedal and the end with 1 inch of thread goes toward the propel pump.*

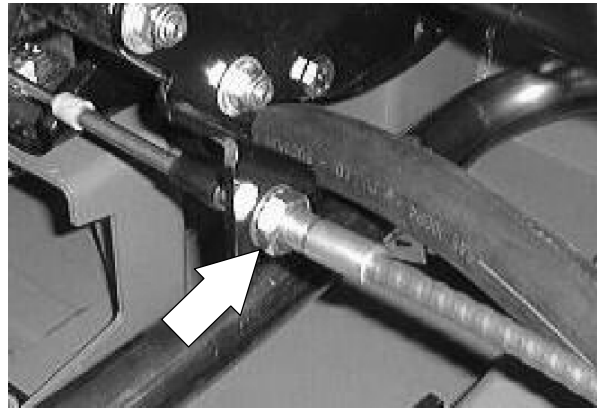

- Install the directional spring on the new directional cable. Position the spring in the same location on the new cable as the old one.

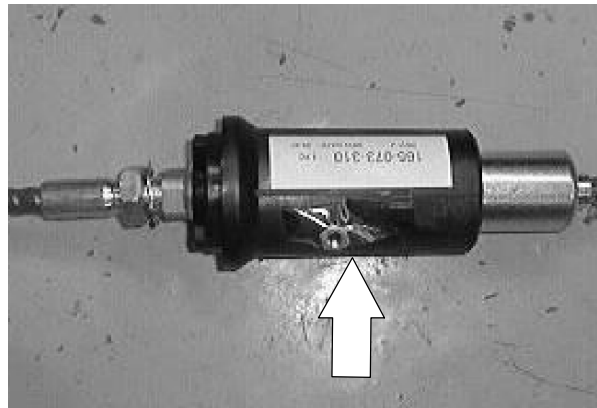

- Place the directional spring in the mount slot on the front of the operators compartment. Tighten the large jam nut firmly.

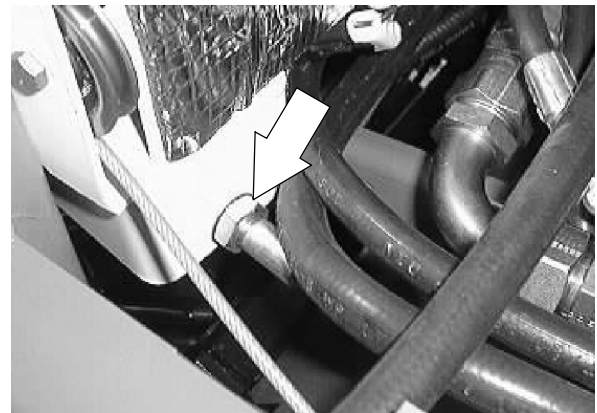

- Reinstall the jam nut and ball joint onto the directional cable and spring in the same location as it was removed. Tighten the jam nut against the ball joint.

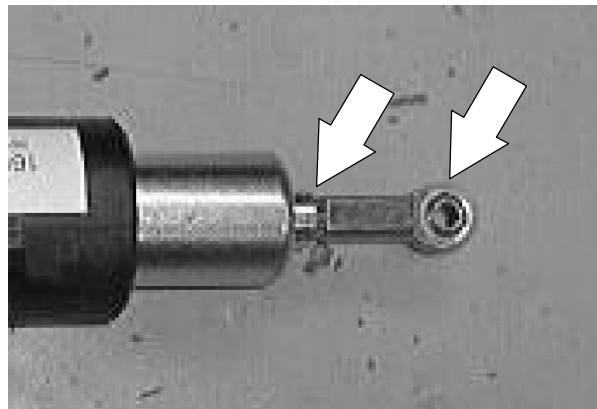



18. Reinstall the ball joint into the mount hole in the directional pedal. Tighten the nyloc nut tight.

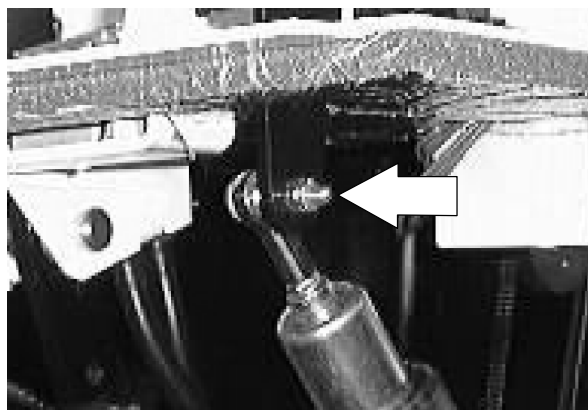

19. Go to the area near the engine and propel pump. Position the new cable in the slot on the mount bracket near the propel pump. Tighten the large jam nut tight.

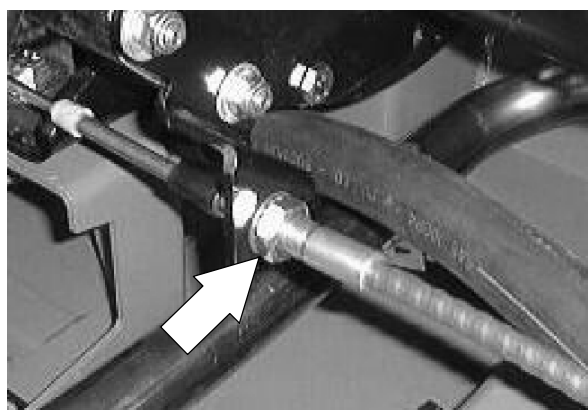

20. Reinstall the 1st jam nut, cable bracket, rubber washer, 2nd jam nut, and ball end. Tighten the jam nuts in the same location as they were removed.

*NOTE: Make note of the location of the 2nd jam nut for proper re-assembly.*

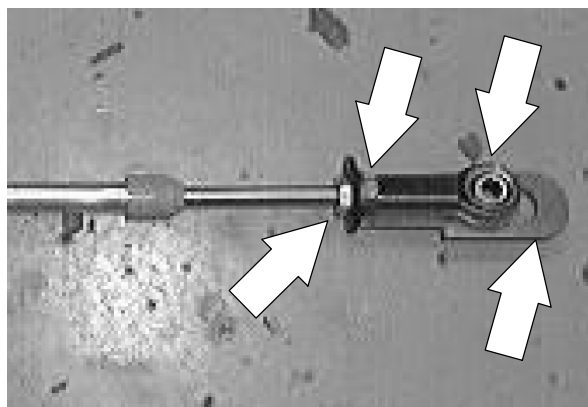

21. Install a new plastic wire tie around the cable bracket. Reinstall the front rubber firewall.

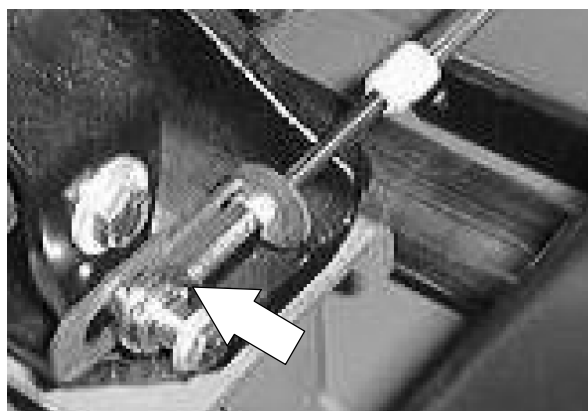

## HYDRAULICS

22. Reconnect the cable ball end to the propel pump arm. Tighten the hex screw to 11 - 14 Nm (7 - 10 ft lb).

*NOTE: Make sure the spacers are in place under the ball end.*

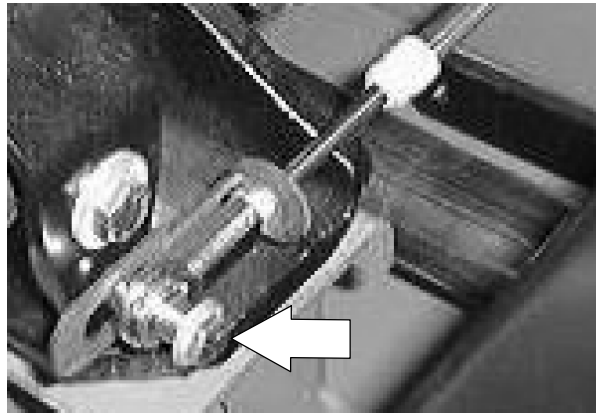

23. Reinstall the radiator grill guard and two mounting screws. Tighten to 18 - 24 Nm (15 - 20 ft lb).



24. Reinstall the floor plate and three mounting screws. Tighten to 18 - 24 Nm (15 - 20 ft lb).

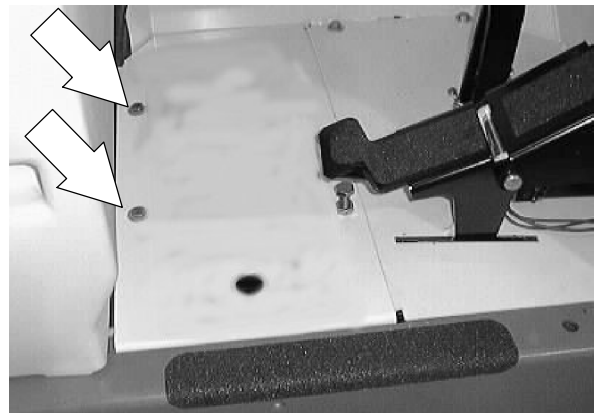

25. Raise the rear of the machine and install jack stands under the frame.
26. Start the machine and raise the scrub head. Check the rear drive wheel for any rotation. Adjust if necessary. See TO ADJUST NEUTRAL CENTERING instructions.
27. Remove the jack stands and lower the machine.
28. Operate the machine and check for proper operation.

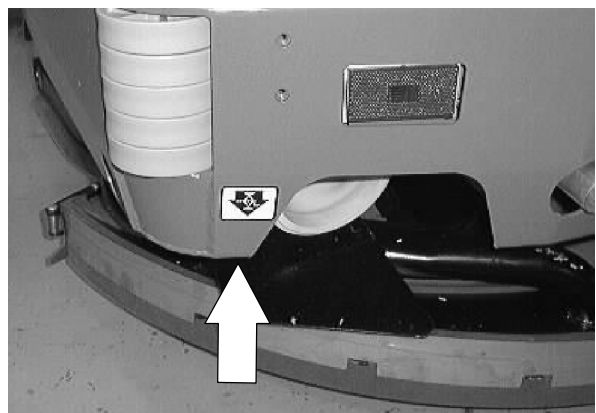

**TO ADJUST NEUTRAL CENTERING**

**FOR SAFETY: Before Leaving Or Servicing Machine; Stop On Level Surface, Set Parking Brake, Turn Off Machine And Remove Key.**

1. Raise the rear of the machine and install jack stands under the machine frame.

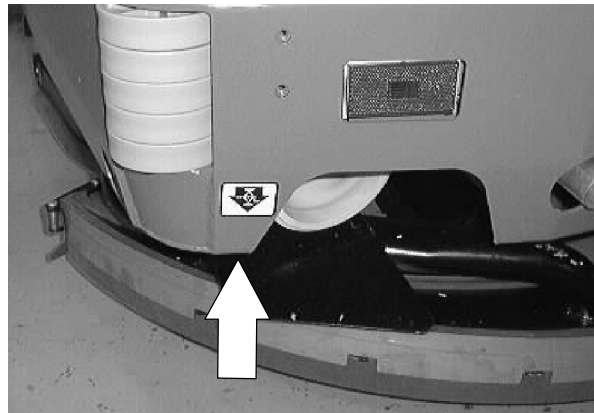

2. Start the machine and check the rear tire for any rotation. If the tire is rotating in either direction the neutral centering needs to be adjusted.

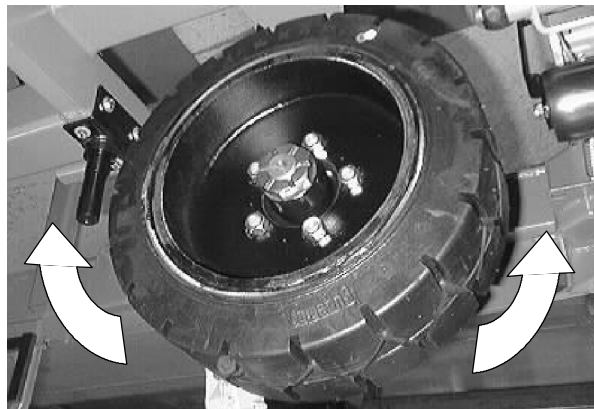

3. Loosen the two outside hex screws on the directional arm where it attaches to the pump hub. Leave the center screw tight.

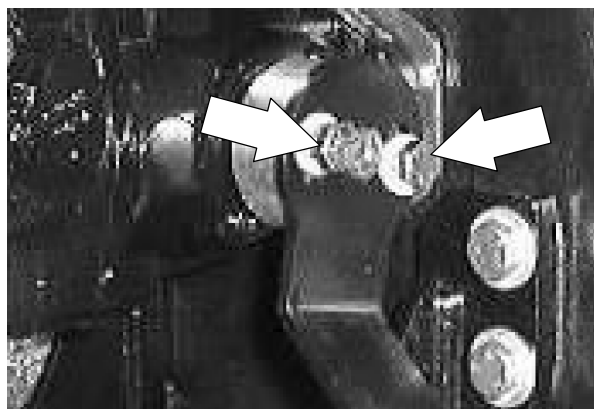

## HYDRAULICS

4. Rotate the pump hub, under the directional arm, either clockwise or counter clockwise to achieve neutral centering.

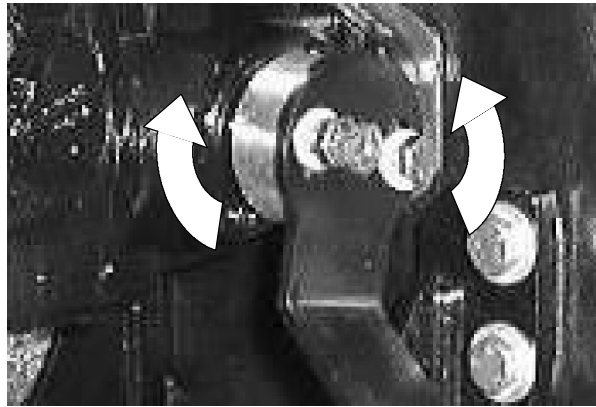

5. Check to make sure the rear tire is not turning with the engine running. If the tire is not turning--tighten the two hex screws to 18 - 24 Nm (15 - 20 ft lb).

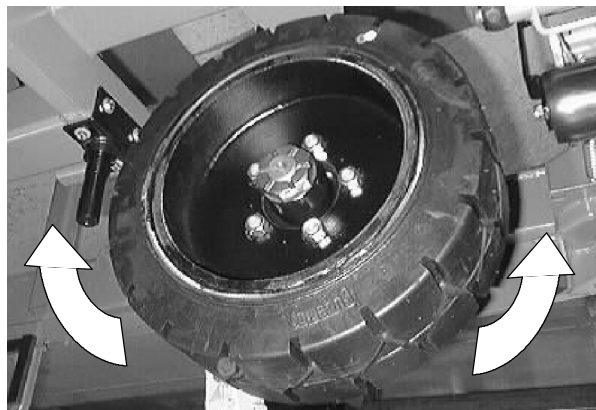

6. Remove the jack stands and lower the machine. Check to make sure the machine does not creep in neutral.

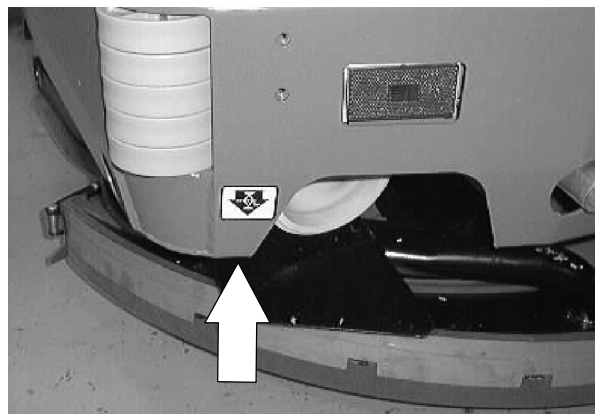

**TO REPLACE HOPPER LIFT CYLINDER**

1. Empty the debris hopper.

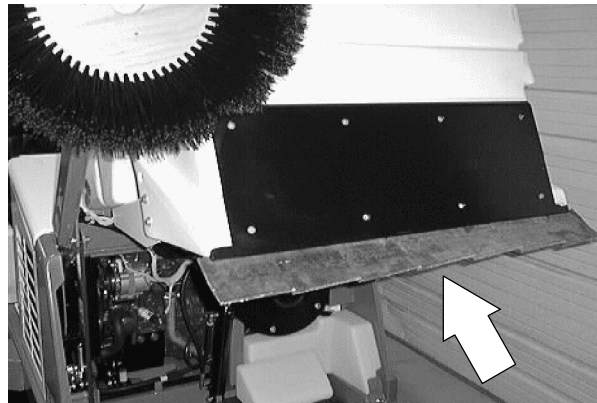

2. Set the machine parking brake.

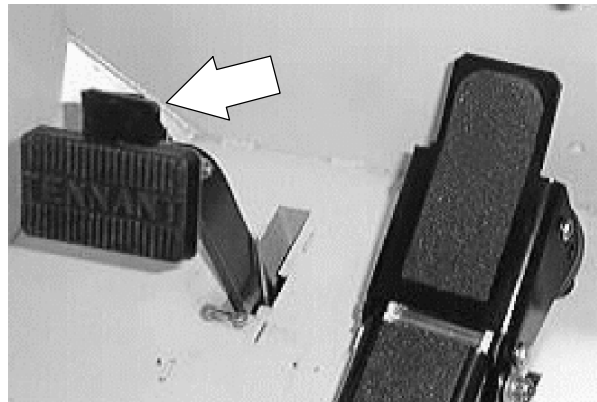

3. Raise the hopper and engage the prop arm. Shut off the engine. Move the hopper lift handle back and forth a few times.

*NOTE: Make sure the hopper is resting down onto the hopper support bar.*

**⚠ WARNING: Raised Hopper May Fall. Engage Hopper Support Bar.**

**FOR SAFETY: Before Leaving Or Servicing Machine; Stop On Level Surface, Set Parking Brake, Turn Off Machine And Remove Key.**

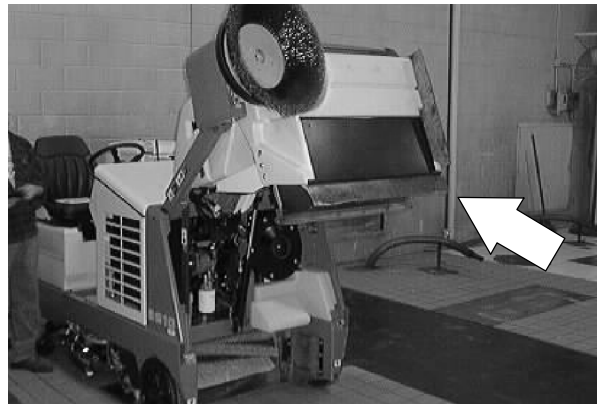

4. Place a drain pan under the hopper lift cylinder. Loosen the hose fitting on the bottom of the cylinder. After the hydraulic oil stop flowing, disconnect and plug the bottom hose.

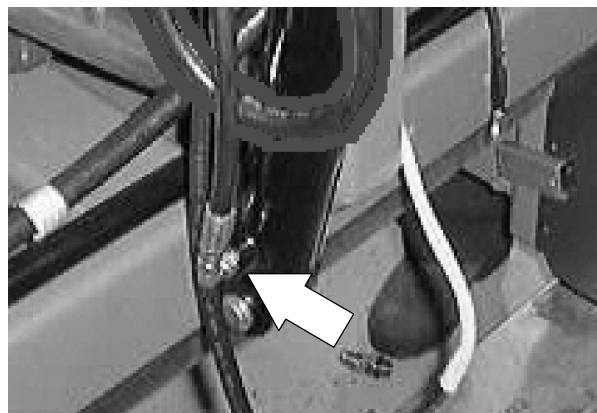

## HYDRAULICS

5. Mark, disconnect, and cap the two hydraulic hose leading to the top of the lift cylinder.

*NOTE: Always observe hydraulic cleanliness requirements when opening hydraulic lines.*

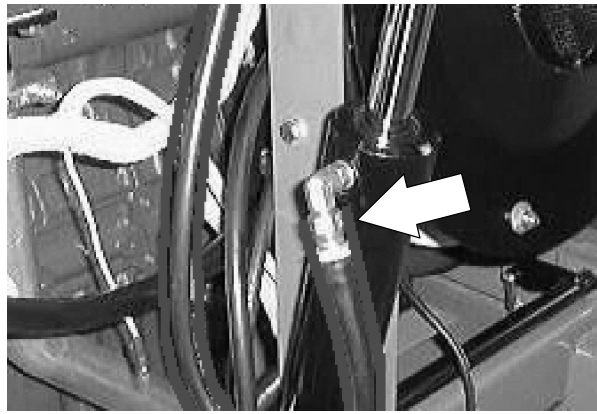

6. Remove the screw holding the upper cylinder pin to the cylinder clevis. Push the pin out of the clevis.

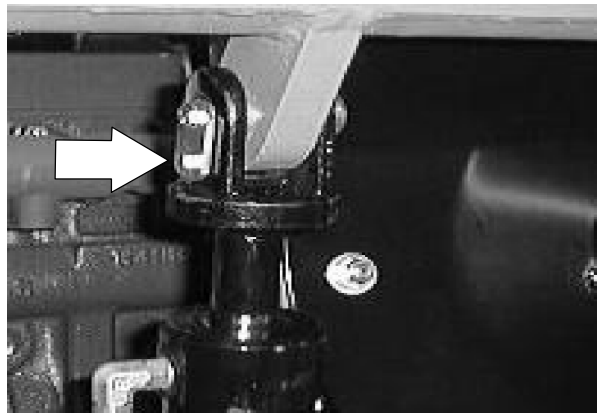

7. Remove the "C" clip from the clevis pin on the lower end of the hopper lift cylinder. Remove the clevis pin.

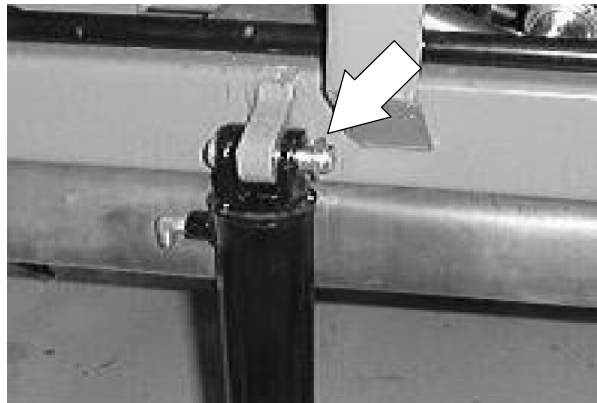

8. Remove the hopper lift cylinder from the machine.



- Remove the fittings from the old cylinder and install in the new cylinder in the same orientation.

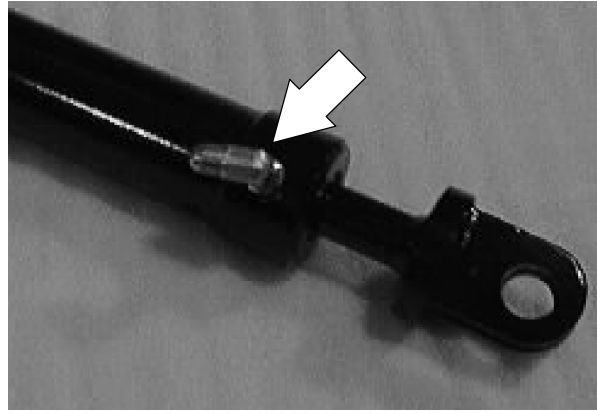

- Position the new cylinder in the machine with the rod end pointing up.

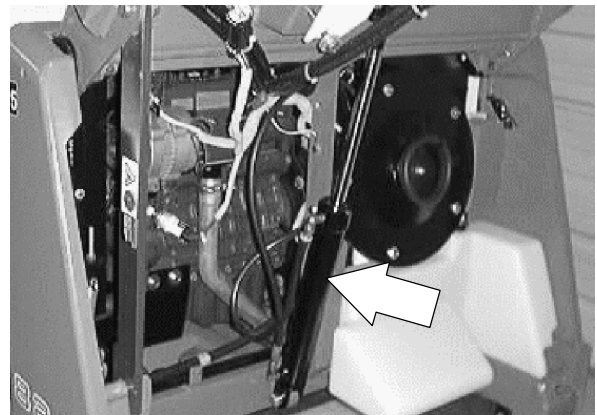

- Align the bottom of the lift cylinder with the hole in the frame mount lug. Reinstall the clevis pin and "C" clip.

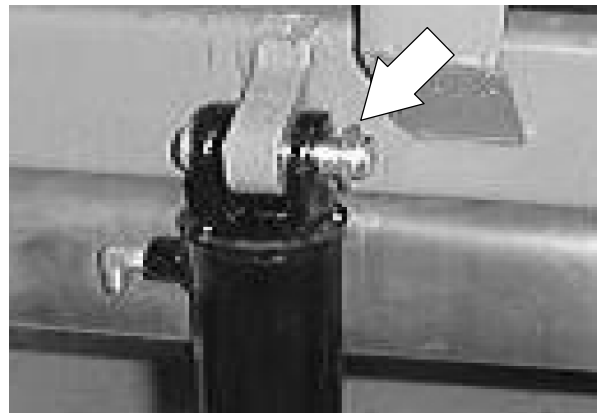

- Align the top cylinder clevis with the hole in the lift arm cylinder mounting lug. Reinstall the clevis pin and hex screw. Install the pin so the hex screw is on the operators side of the machine.

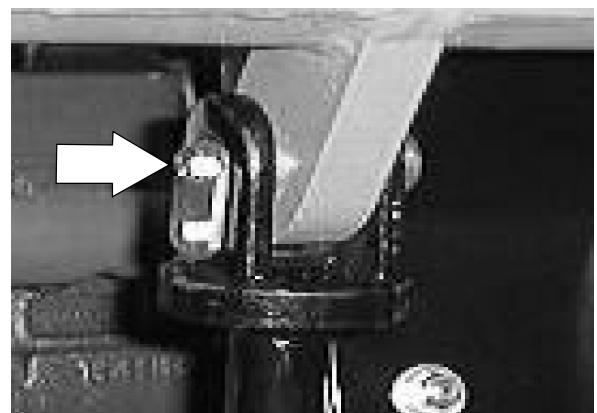

## HYDRAULICS

13. Reconnect the hydraulic hoses to the new cylinder. See schematic in this section.

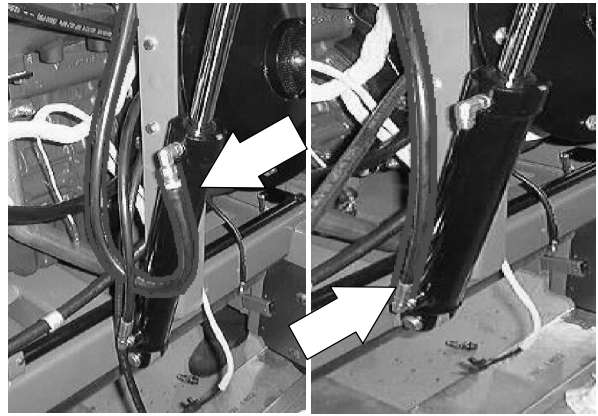

14. Start the machine and lower the hopper. Check for any leaks and proper operation.

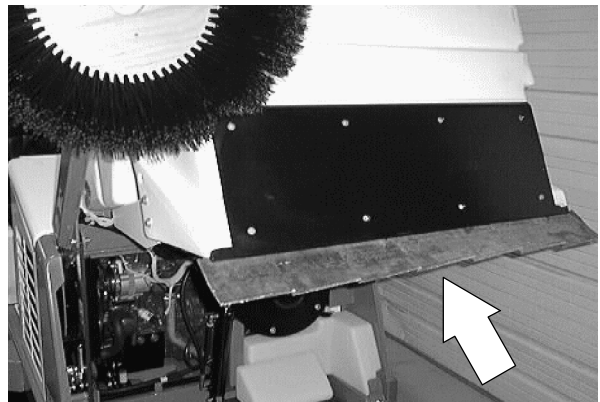



**TO REPLACE HOPPER DUMP DOOR CYLINDER**

1. Dump the debris hopper. Engage the support bar.

 **WARNING: Raised Hopper May Fall. Engage Hopper Support Bar.**

**FOR SAFETY: Before Leaving Or Servicing Machine; Stop On Level Surface, Set Parking Brake, Turn Off Machine And Remove Key.**

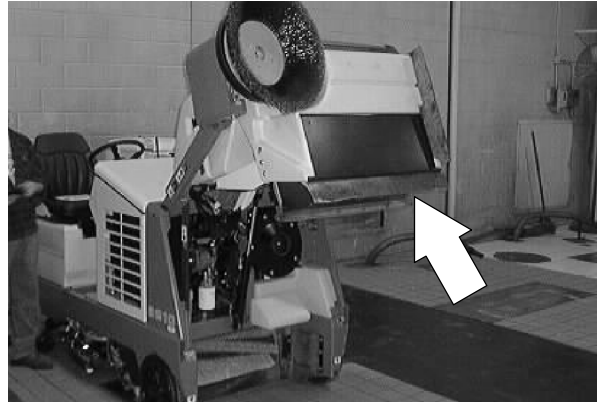

2. Mark, disconnect, and plug the two hoses leading to the hopper dump door cylinder.

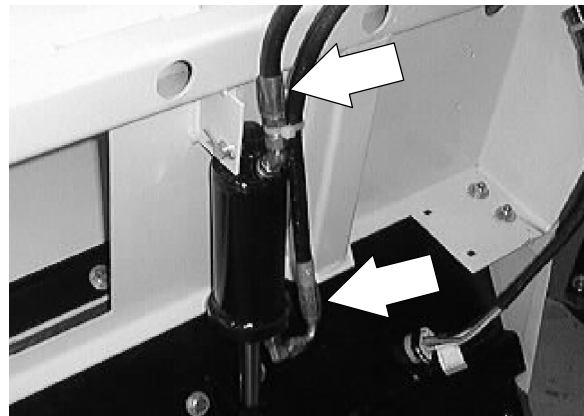

3. Remove the cotter pin and clevis pin from the top of the dump door cylinder where it attaches to the center/rear of the debris hopper.



## HYDRAULICS

4. Remove the cotter pin and clevis pin from the bottom of the dump door cylinder where it attaches to the center of the dump door.

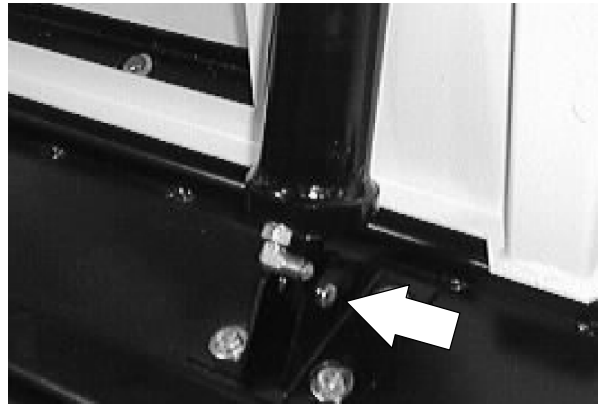

5. Remove the old cylinder from the back of the hopper. Remove the fittings from the old cylinder and install in the new cylinder in the same orientation.

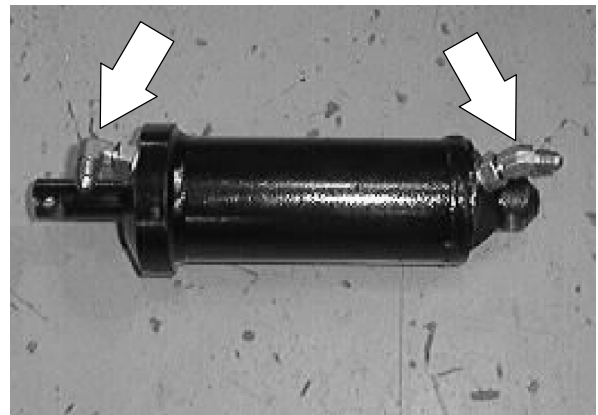

6. Position the new cylinder in the machine with the rod end pointing to the center of the dump door.

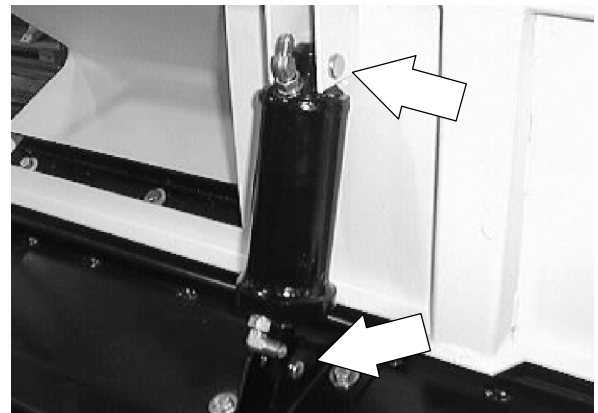

7. Reinstall the clevis pin and cotter pin in the lower end of the dump door cylinder.

8. Reinstall the clevis pin and cotter pin in the upper end of the dump door cylinder.

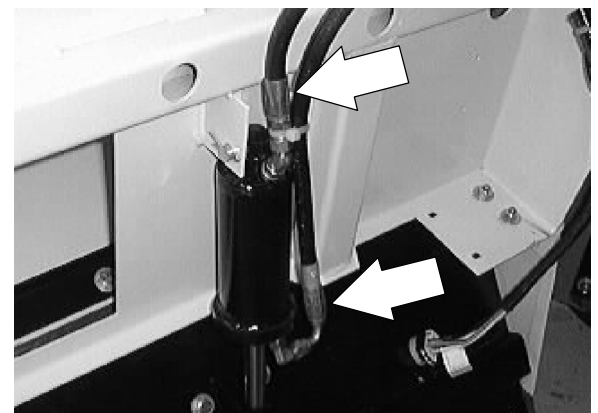

9. Reconnect the hydraulic hoses to the dump door cylinder. See the hose diagram in this section.

10. Start the machine and open and close the hopper dump door. Check for any leaks and proper operation.

**TO REPLACE MAIN BRUSH LIFT CYLINDER  
(8210 only)**

1. Start the machine and lower the main brush. Turn off the machine.

**FOR SAFETY: Before Leaving Or Servicing Machine; Stop On Level Surface, Set Parking Brake.**

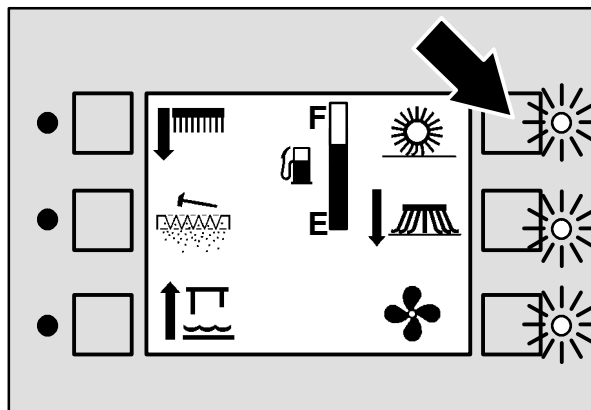

2. Locate the main brush lift cylinder access panel on the inside wall of the operator compartment. Remove the five screws holding the access panel to the operator compartment. Remove the panel.

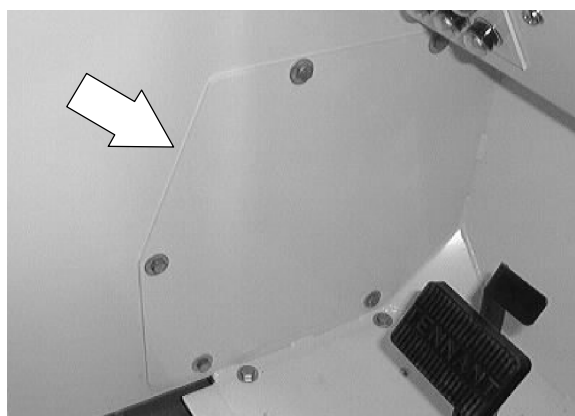

3. Mark, disconnect, and plug the two hoses leading to the main brush lift cylinder.

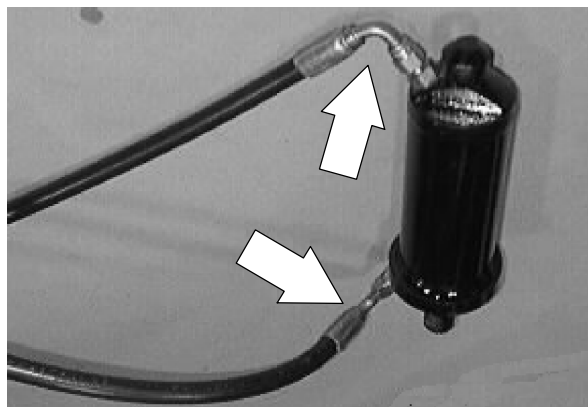

## HYDRAULICS

4. Remove the cotter pin and clevis pin from the top of the main brush lift cylinder where it attaches to the main brush lift arm.

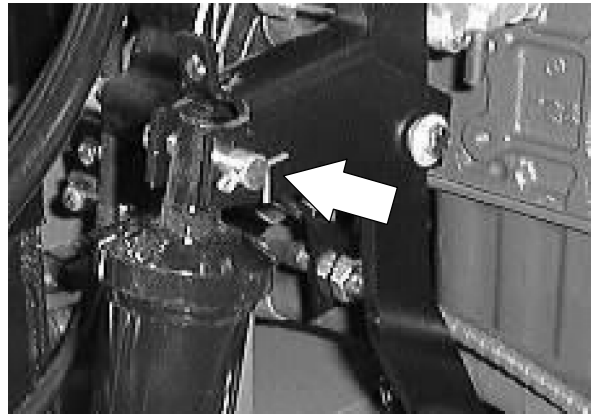

5. Remove the cotter pin and clevis pin from the bottom of the main brush lift cylinder where it attaches to the machine frame.



6. Remove the main brush lift cylinder through the access panel opening.

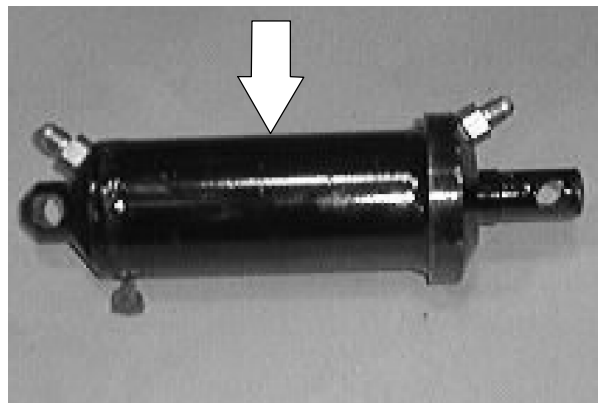

7. Remove the fittings from the old main brush lift cylinder and install in the new cylinder in the same orientation.

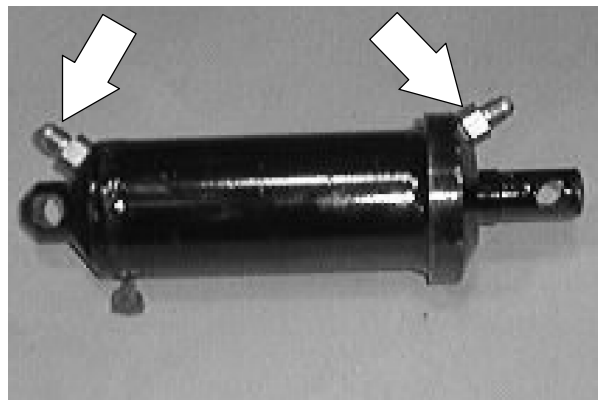

- Position the new cylinder in the machine with the rod end pointing up.

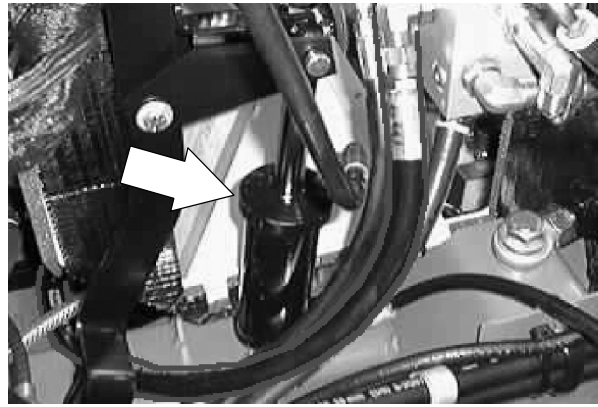

- Reinstall the clevis pins and cotter pins in the upper and lower ends of the new main brush lift cylinder.

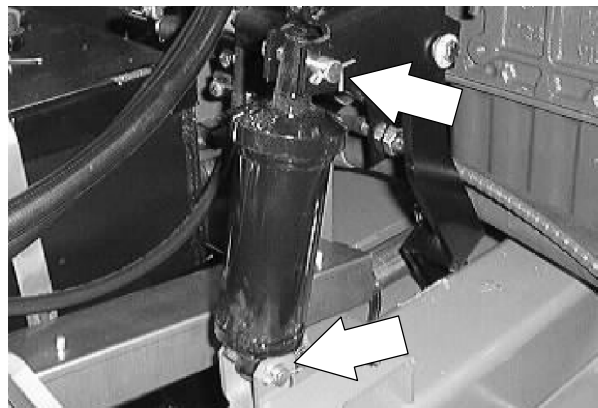

- Reconnect the hydraulic hoses to the main brush lift cylinder. See the hose diagram in this section.

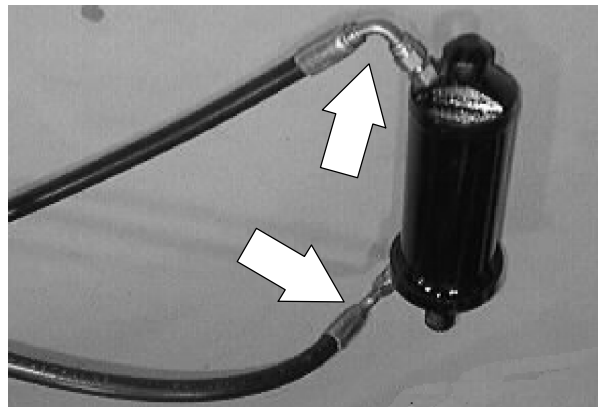

- Start the machine and raise and lower the main brush. Check for any leaks and proper operation.



- Reinstall the main brush lift cylinder access panel on the inside wall of the operator compartment.

## HYDRAULICS

### TO REPLACE SIDE BRUSH LIFT CYLINDER (8210 only)

1. Empty the debris hopper.

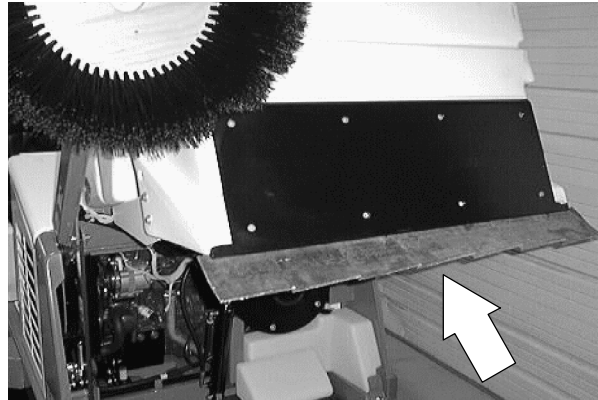

2. Set the machine parking brake.

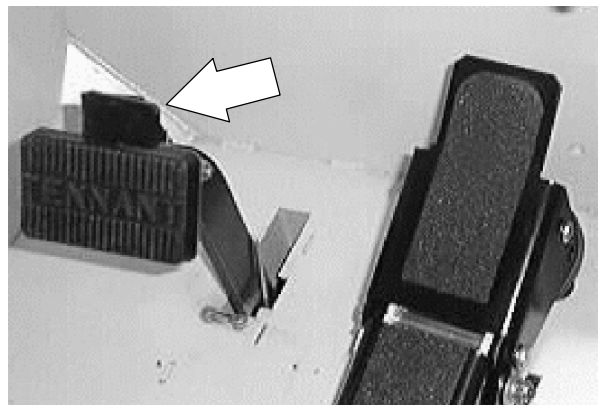

3. Raise the hopper and engage the prop arm. Shut off the engine. Move the hopper lift handle back and forth a few times.

*NOTE: Make sure the hopper is resting down onto the hopper support bar.*



**WARNING: Raised Hopper May Fall.  
Engage Hopper Support Bar.**

**FOR SAFETY: Before Leaving Or  
Servicing Machine; Stop On Level  
Surface, Set Parking Brake, Turn Off  
Machine And Remove Key.**

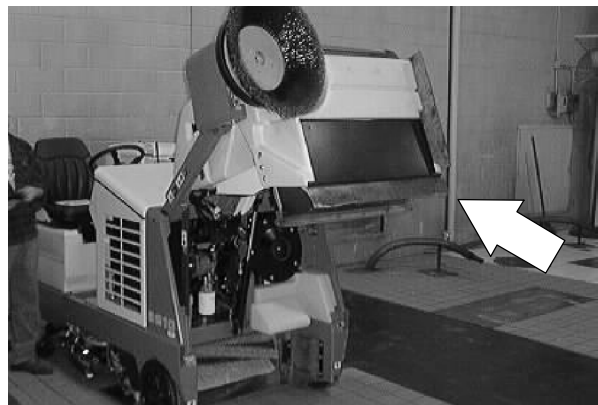

- Place a drain pan under the side brush lift cylinder. Loosen the hose fitting on the bottom of the cylinder.

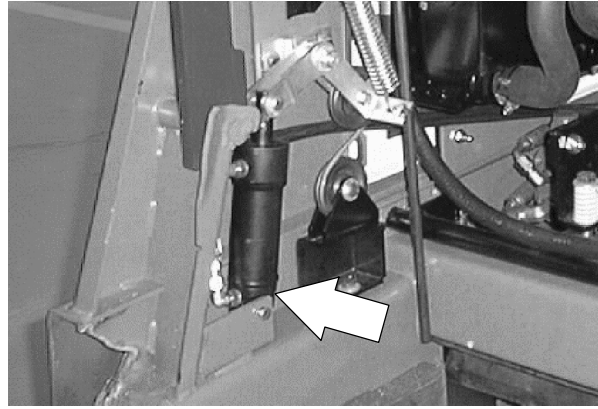

- Mark, disconnect, and cap the two hydraulic hoses leading to the side brush lift cylinder.

*NOTE: Always observe hydraulic cleanliness requirements when opening hydraulic lines.*

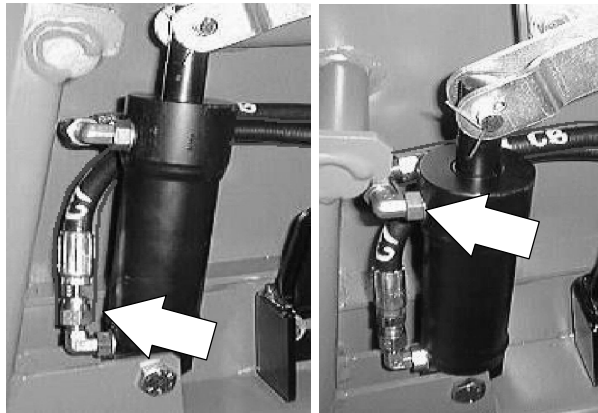

- Remove the cotter pin and clevis pin holding the top of the side brush lift cylinder to the machine pivot bracket.

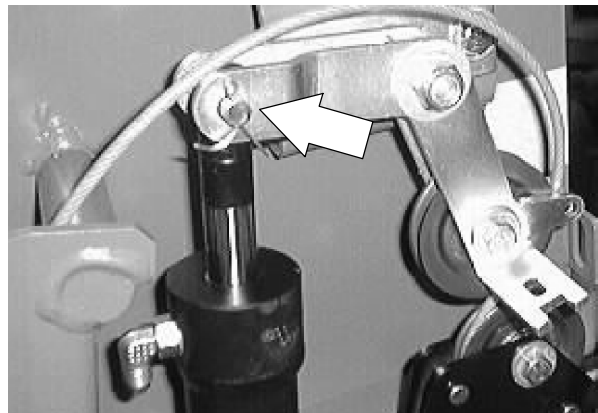

- Remove the M10 hex screw and nut holding the bottom of the lift cylinder to the machine frame. Remove the lift cylinder from the machine.

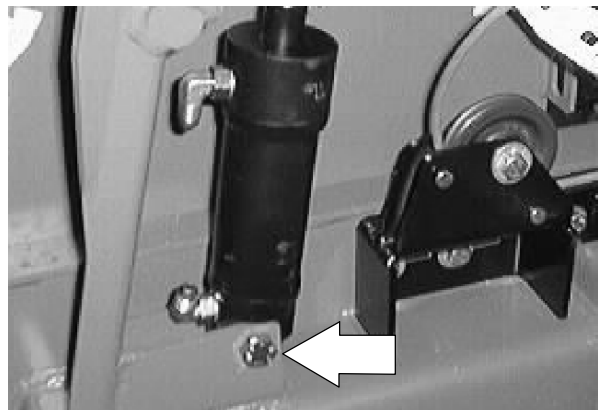

## HYDRAULICS

8. Remove the fittings from the old cylinder and install in the new cylinder in the same orientation.

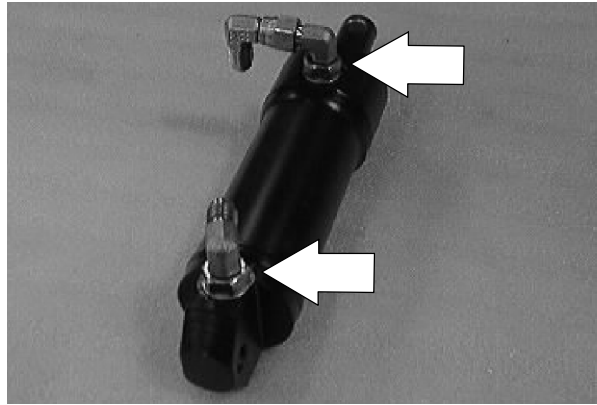

9. Position the new cylinder in the machine with the rod end pointing up.

10. Reinstall the clevis pin and cotter pin in the rod end of the dump door cylinder where it attaches to the pivot bracket.

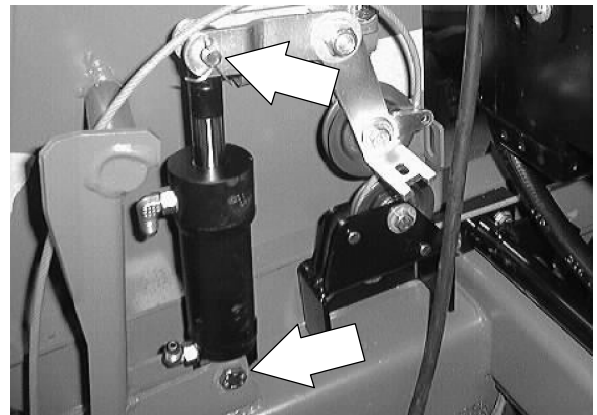

11. Reinstall the M10 hex screw and nut in the lower end of the side brush lift cylinder where it attaches to the frame. Tighten to 37 - 48 Nm (26 - 34 ft lb).

12. Reconnect the hydraulic hoses to the side brush lift cylinder. See the hose diagram in this section.

*NOTE: Always observe hydraulic cleanliness requirements when opening hydraulic lines.*

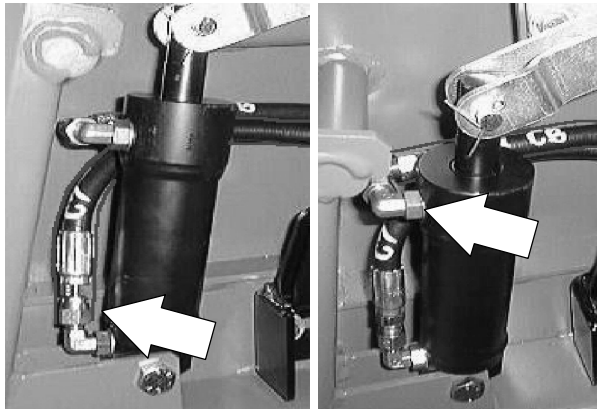

13. Start the machine and disengage the prop arm. Lower the hopper.



14. Operate the machine and raise and lower the side brush. Check for any leaks and proper operation.



**TO REPLACE SCRUB HEAD SIDE SHIFT CYLINDER (optional on 8200, std on 8210)**

1. Start the machine and lower the scrub head. Turn off the machine.

**FOR SAFETY: Before Leaving Or Servicing Machine; Stop On Level Surface, Set Parking Brake, Turn Off Machine And Remove Key.**

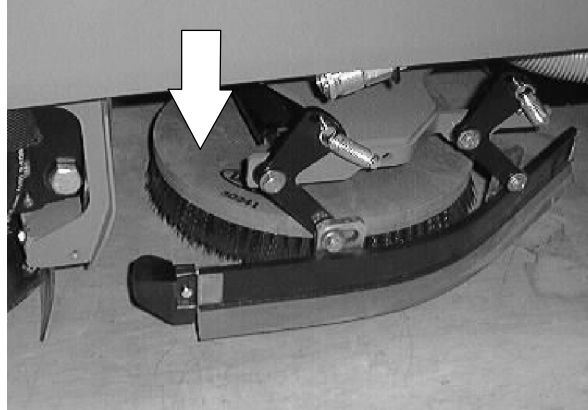

2. Go under the machine frame on the left hand side. Locate the side shift hydraulic cylinder above the scrub head.



3. Mark, disconnect, and cap the two hydraulic hoses leading to the scrub head side shift cylinder.

*NOTE: Always observe hydraulic cleanliness requirements when opening hydraulic lines.*

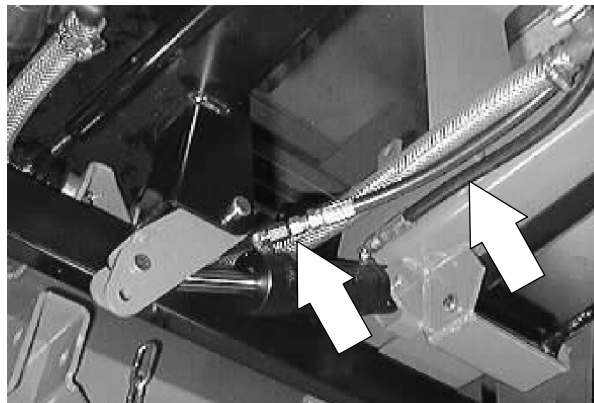

## HYDRAULICS

4. Remove the cotter pin and clevis pin from the rod end of the side shift cylinder.

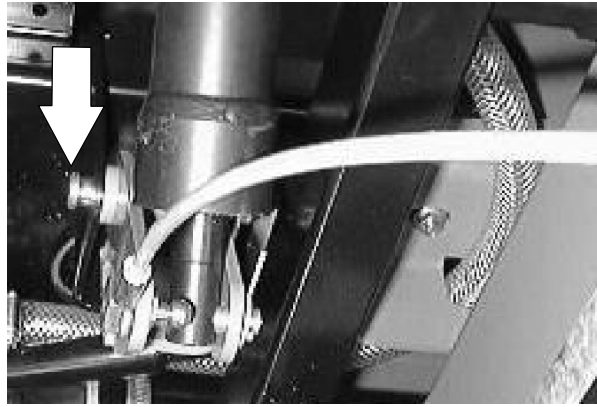

5. Remove the clevis pin and cotter pin from the top of the side shift cylinder. Remove the cylinder from the machine.

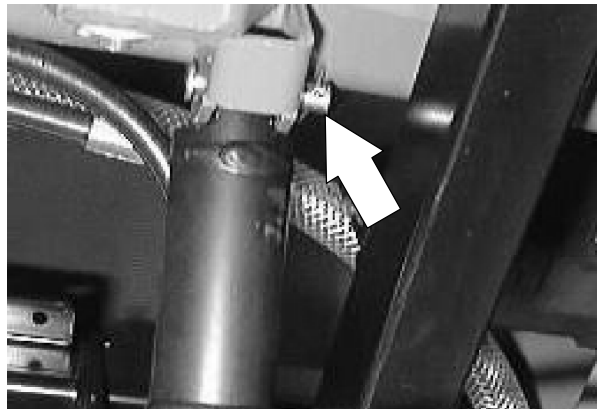

6. Remove the fittings from old cylinder. Install the fittings in the new cylinder in the same orientation.

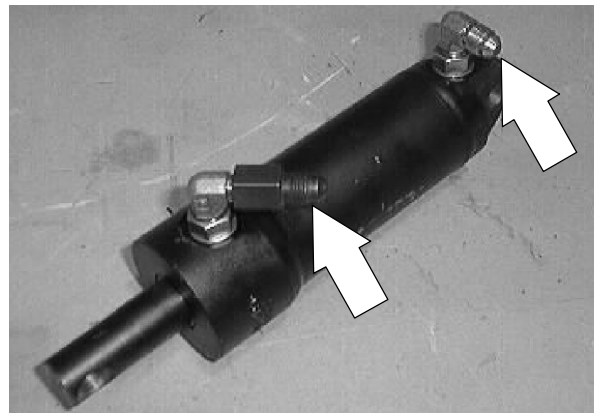

7. Position the new cylinder in the machine with the rod end pointing toward the right side of the machine. Install both clevis pins and cotter pins.

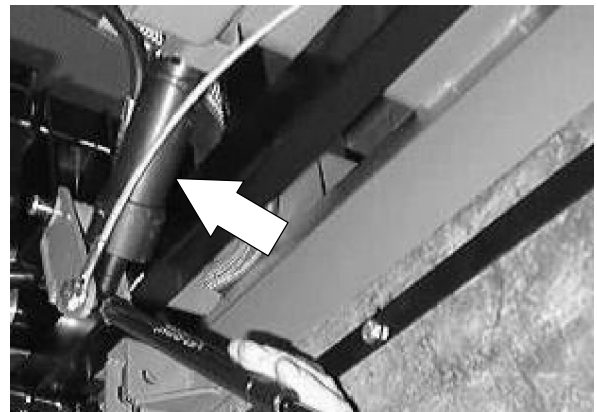

8. Connect the hydraulic hoses to the new side shift cylinder. See the hose diagram in this section.

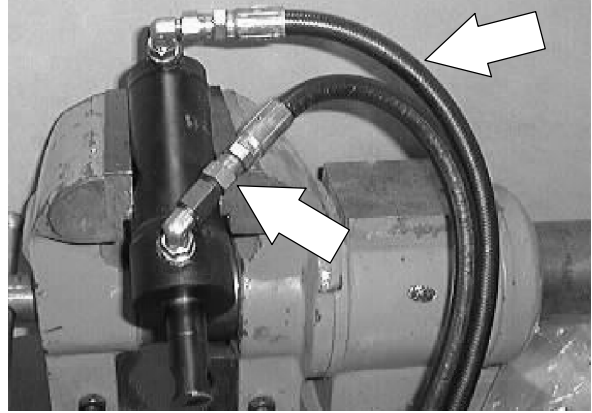

9. Start the machine and raise the scrub head.

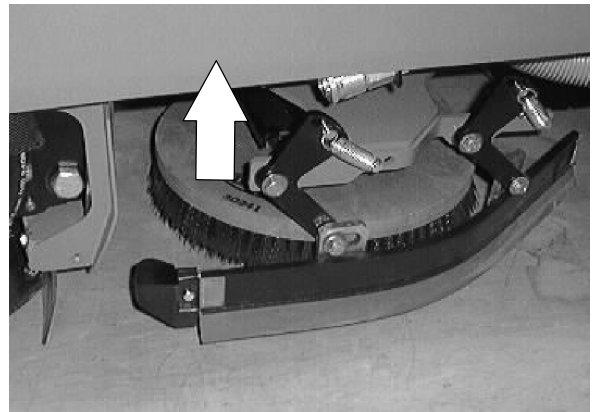

10. Start the machine and operate the scrub head side shift button. Check for proper operation.

## HYDRAULICS

### TO REPLACE SCRUB HEAD LIFT CYLINDER

1. Start the machine and lower the scrub head. Turn off the machine.

**FOR SAFETY: Before Leaving Or Servicing Machine; Stop On Level Surface, Set Parking Brake, Turn Off Machine And Remove Key.**

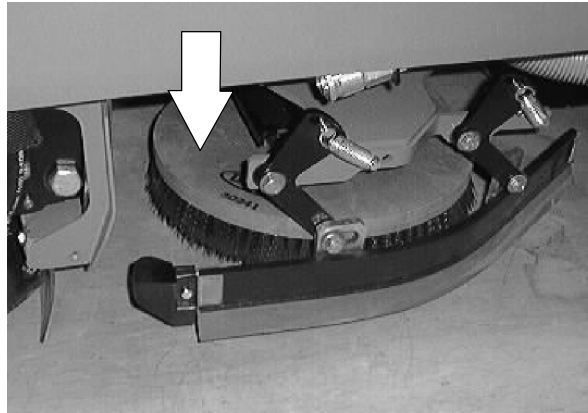

2. Remove the three screws holding the floor plate in the operators compartment. Remove the floor plate.

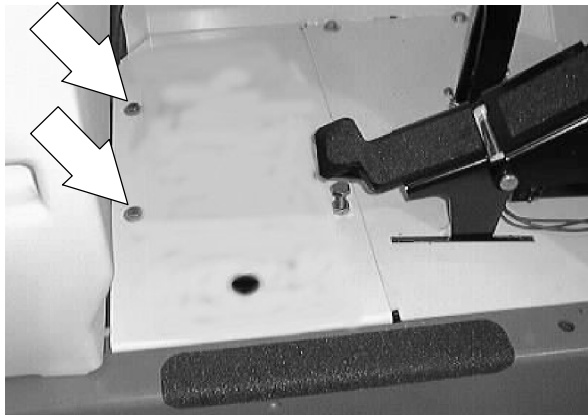

3. Go under the machine frame on the right hand side, above the scrub head. Locate the scrub head lift cylinder.

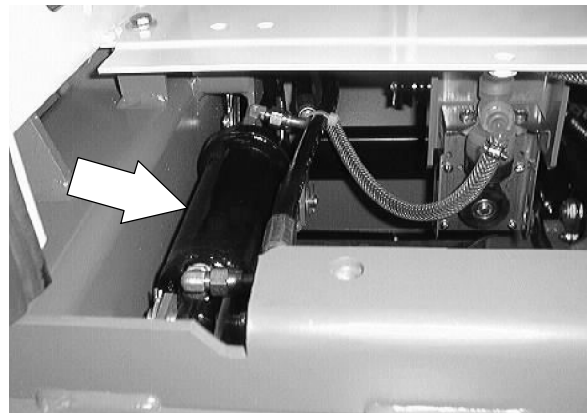

4. Mark, disconnect, and cap the two hydraulic hoses leading to the scrub head lift cylinder.

*NOTE: Always observe hydraulic cleanliness requirements when opening hydraulic lines.*

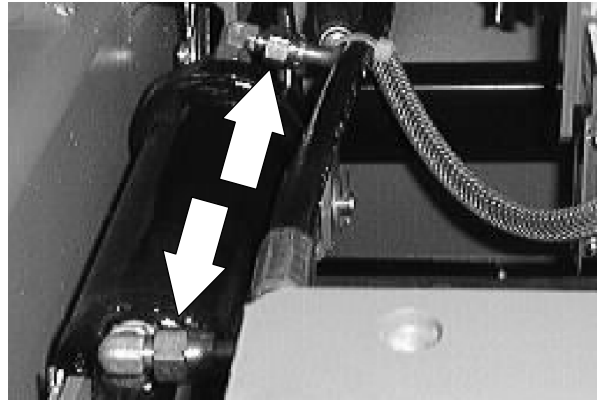

5. Remove the cotter pins and clevis pins from both ends of the scrub head lift cylinder. Remove the lift cylinder from the machine.

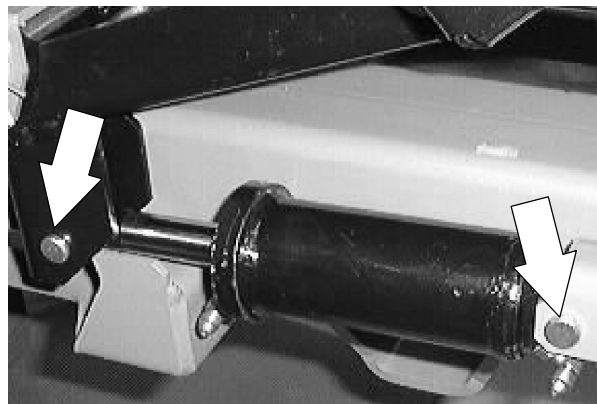

6. Remove the fittings from old cylinder. Install the fittings in the new cylinder in the same orientation.

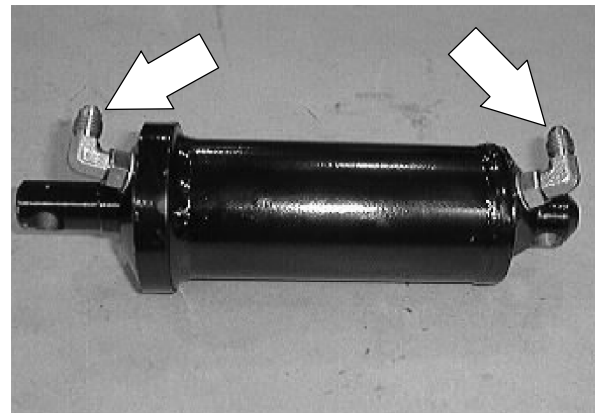

7. Position the new cylinder in the machine with the rod end pointing toward the front of the machine.

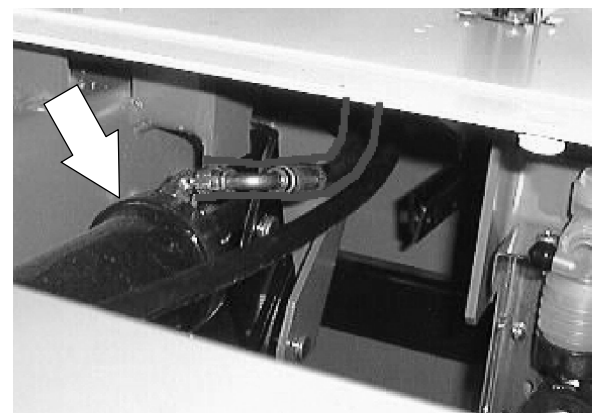

## HYDRAULICS

8. Install both clevis pins and cotter pins.

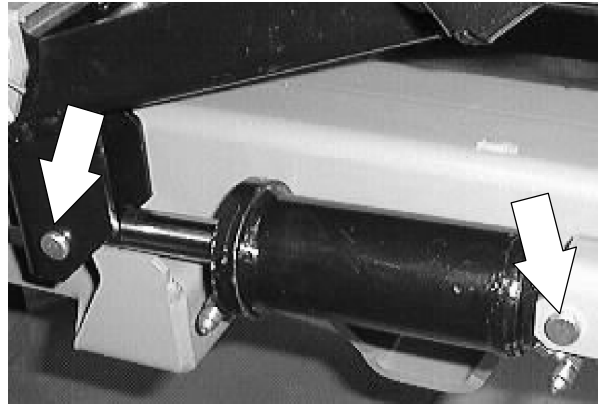

9. Connect the hydraulic hoses to the new scrub head lift cylinder. See the hose diagram in this section.

*NOTE: Always observe hydraulic cleanliness requirements when opening hydraulic lines.*

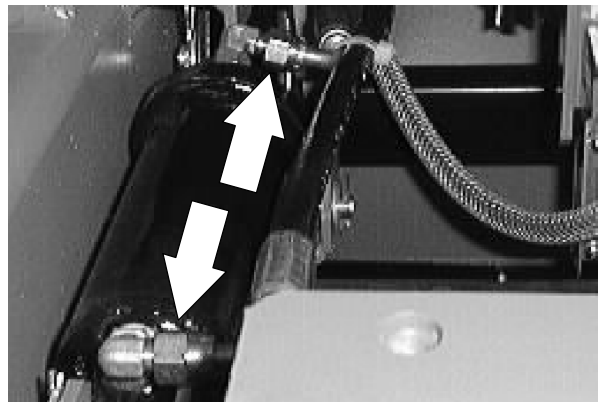

15. Reinstall the floor plate and three mounting screws. Tighten to 18 - 24 Nm (15 - 20 ft lb).

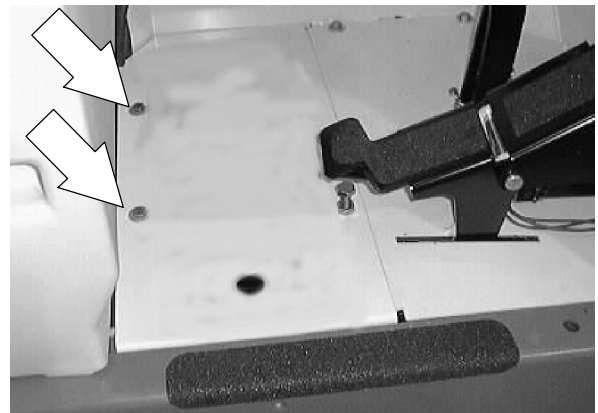

10. Start the machine and operate the scrub head lift button. Check for proper operation.

**TO REPLACE REAR SQUEEGEE LIFT CYLINDER**

1. Start the machine and lower the rear squeegee. Turn off the machine.

**FOR SAFETY: Before Leaving Or Servicing Machine; Stop On Level Surface, Set Parking Brake, Turn Off Machine And Remove Key.**

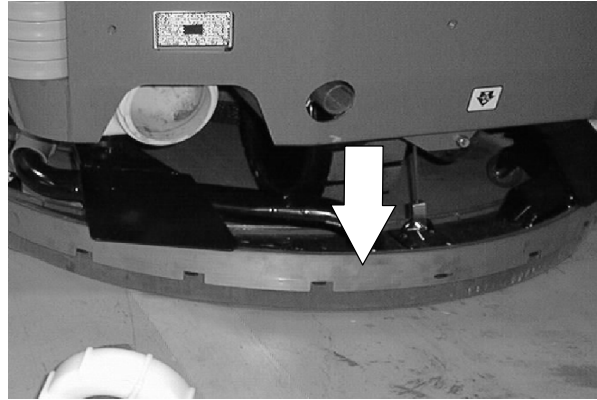

2. Remove the solution tank. See TO REMOVE SOLUTION TANK instructions in the SCRUBBING section.



3. Go under the machine frame at the rear of the machine. Locate the squeegee lift cylinder.



## HYDRAULICS

4. Mark, disconnect, and cap the two hydraulic hoses leading to the squeegee lift cylinder.

*NOTE: Always observe hydraulic cleanliness requirements when opening hydraulic lines.*

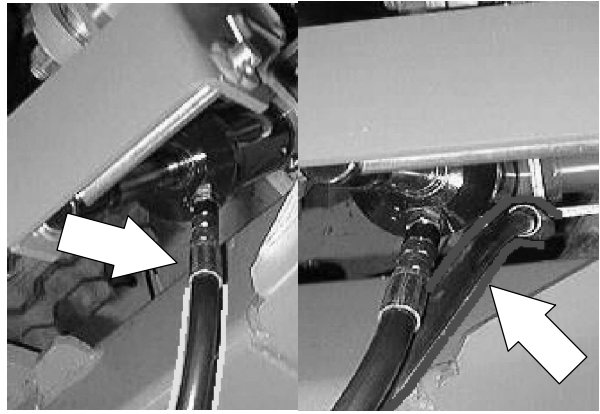

5. Remove the cotter pin and clevis pin from the rod end of the squeegee lift cylinder.

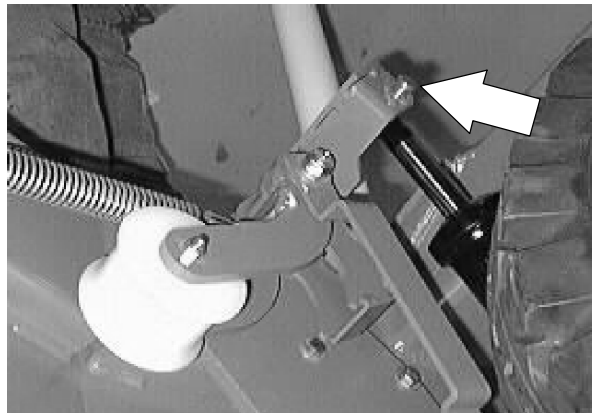

6. Remove the "C" clip from the lower mount pin on the squeegee lift cylinder. Remove the cylinder from the machine.

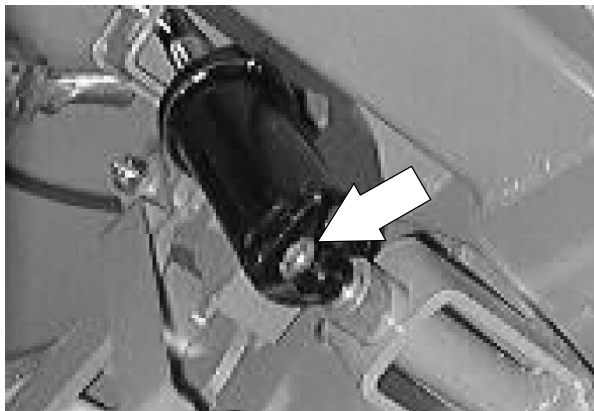

7. Remove the fittings from old cylinder. Install the fittings in the new cylinder in the same orientation.

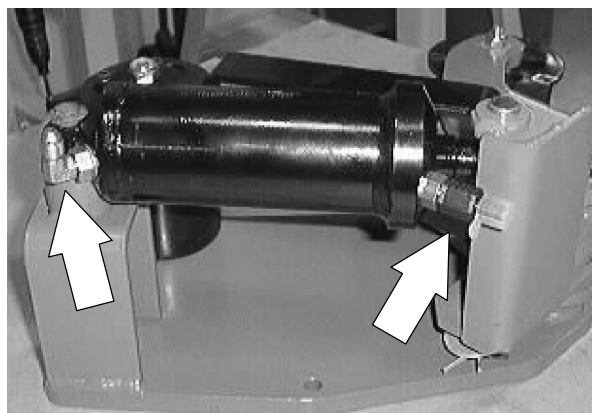



- Position the new cylinder in the machine with the rod end pointing upward.

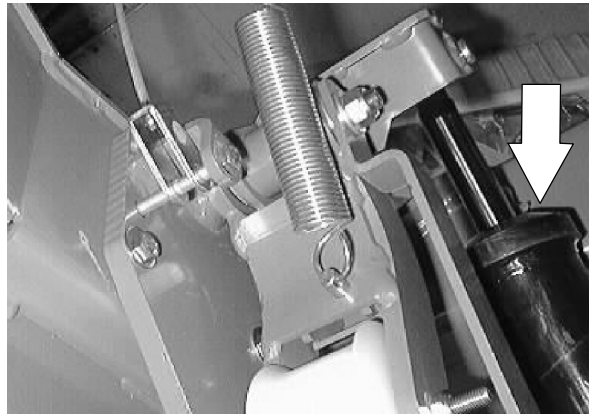

- Install the clevis pin and cotter pin in the rod end of the cylinder.

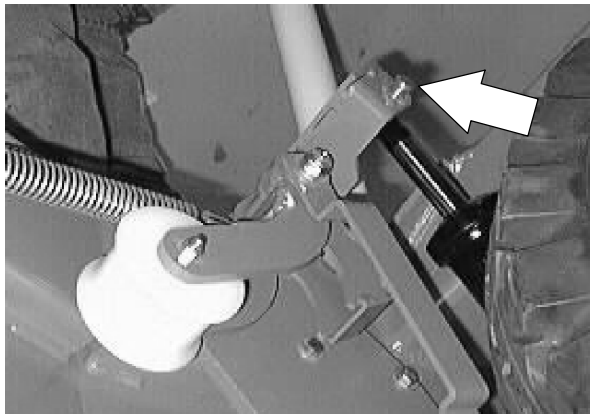

- Install the "C" clip on the lower mount pin.

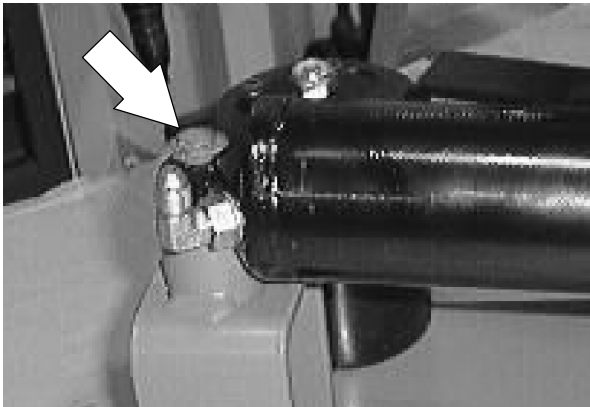

- Connect the hydraulic hoses to the new squeegee lift cylinder. See the hose diagram in this section.

*NOTE: Always observe hydraulic cleanliness requirements when opening hydraulic lines.*



## HYDRAULICS

12. Reinstall the solution tank. See TO INSTALL SOLUTION TANK instructions in the SCRUBBING section.



13. Start the machine and operate the squeegee lift button. Check for proper operation.

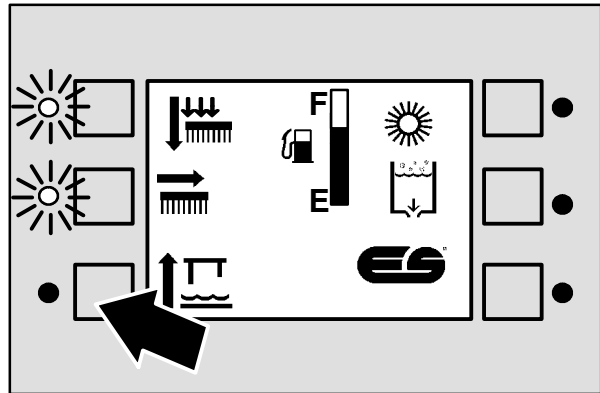

**TO REPLACE STEERING CYLINDER**

1. Raise the rear of the machine. Put jack stands under the rear frame.

**FOR SAFETY: Before Leaving Or Servicing Machine; Stop On Level Surface, Set Parking Brake., Turn Off Machine And Remove Key.**

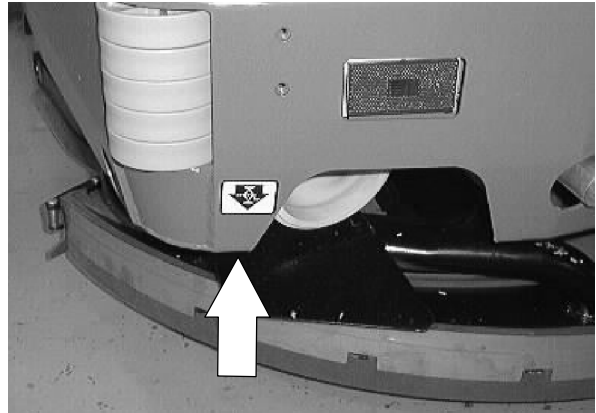

2. Remove the solution tank. See TO REMOVE SOLUTION TANK instructions in the SCRUBBING section.



3. Remove the clamp holding the drive motor hydraulic hoses to rear casting. Move the hoses to gain access to the steering cylinder hardware.

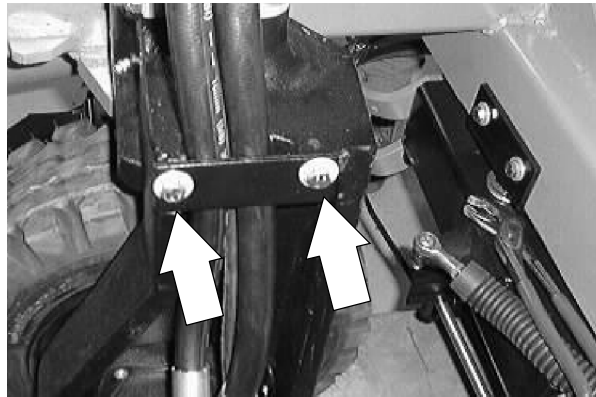

4. Remove the hex screw and nut holding the steering cylinder rod end balljoint to the rear drive casting.

*NOTE: Retain and reuse the flat washers under the balljoint or hex screw.*

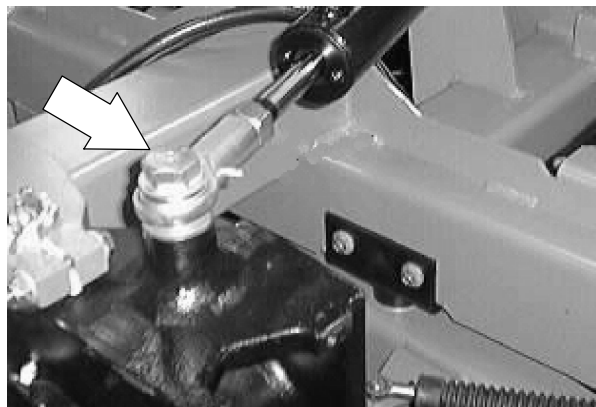

## HYDRAULICS

5. Open the engine cover and side door.

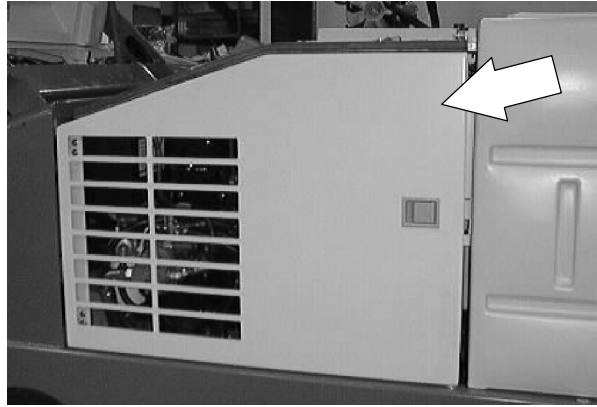

6. Remove the fuel tank or LP tank mount assembly from the machine.

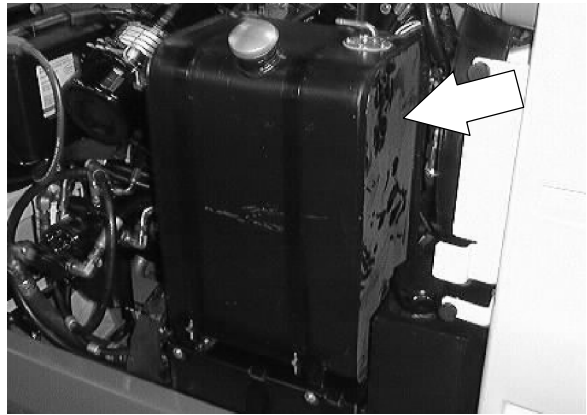

7. Remove the hex screw and nyloc nut holding the piston end of the steering cylinder rod end to the machine frame.



8. Mark, disconnect, and cap the two hydraulic hoses leading to the steering cylinder.

*NOTE: Always observe hydraulic cleanliness requirements when opening hydraulic lines.*

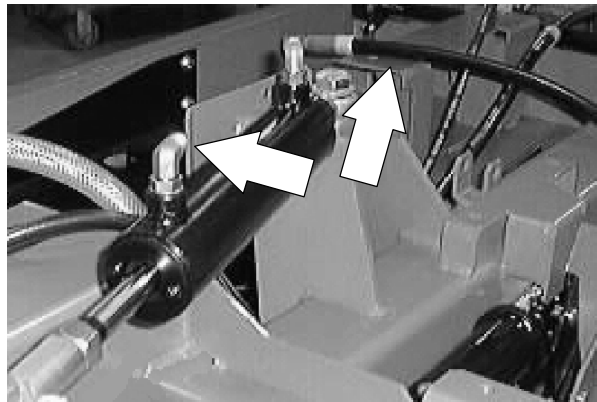

- Remove the steering cylinder from the machine.

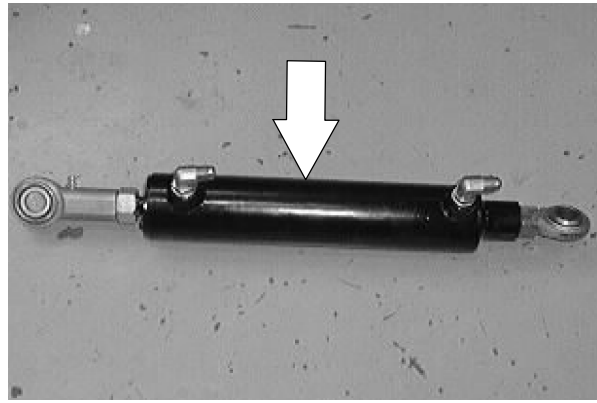

- Remove the ball joint ends from the old cylinder and install on the new cylinder.

*NOTE: Make sure that the balljoints are pointed down and they are turned all the way in until they are bottomed out.*

- Tighten the jam nuts against the balljoints.

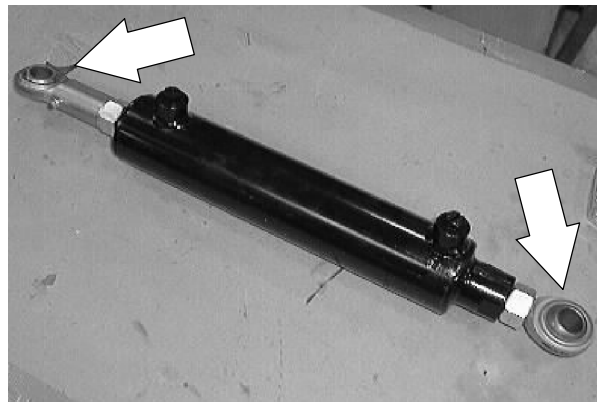

- Remove the fittings from old cylinder. Install the fittings in the new cylinder in the same orientation.

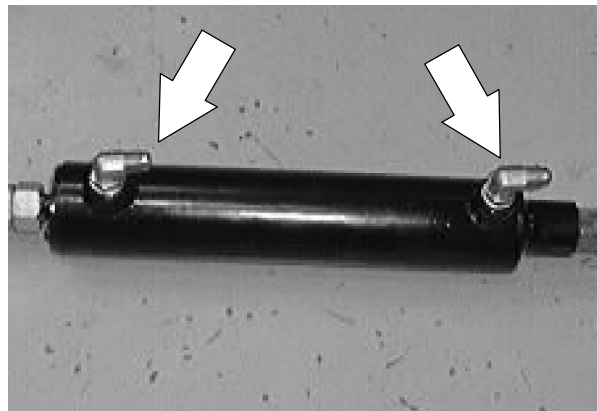

- Position the new steering cylinder and balljoint assembly in the machine with the rod part of the cylinder toward the rear of the machine.



## HYDRAULICS

14. Reinstall the hex screws and nuts on the steering cylinder rod ends. Reinstall any flat washers that were removed earlier. Tighten to 339 Nm (250 ft lb).

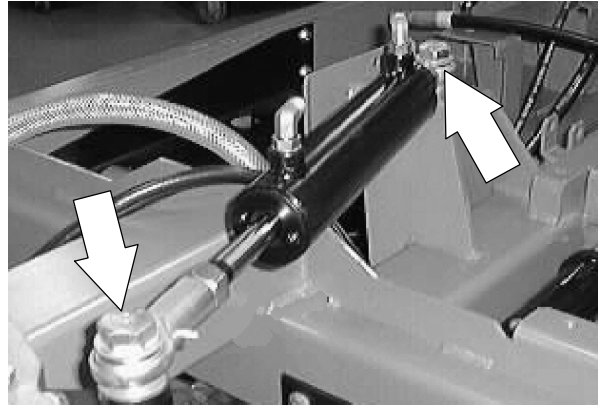

15. Reconnect the hydraulic hoses to the steering cylinder. See schematic in this section.

*NOTE: Always observe hydraulic cleanliness requirements when opening hydraulic lines.*

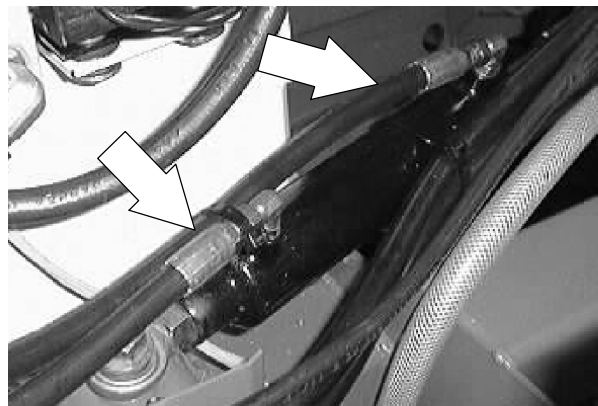

16. Reinstall the clamp holding the drive motor hydraulic hoses to rear casting.

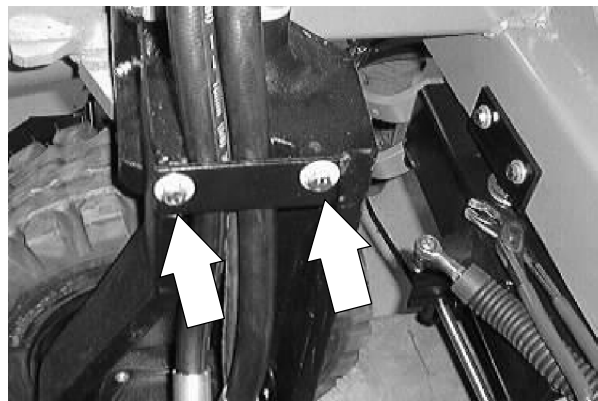

17. Reinstall the solution tank. See TO INSTALL SOLUTION TANK instructions in the SCRUBBING section.



18. Reinstall the fuel tank or LP tank mount assembly.

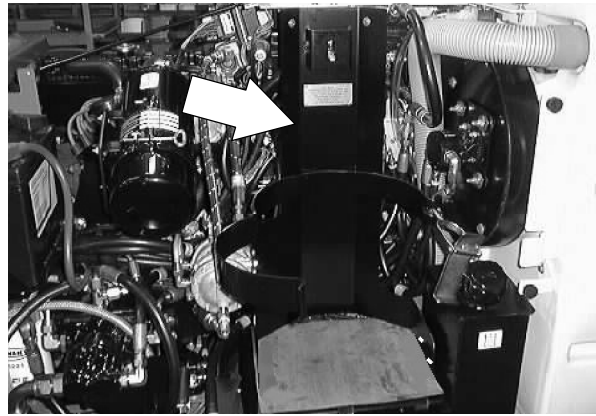

19. Remove the jack stands from machine and lower.

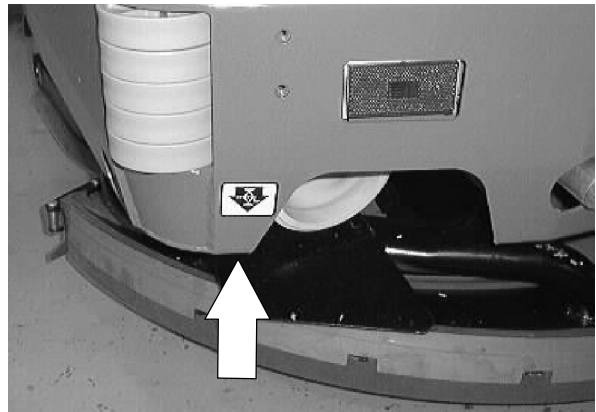

20. Start machine and turn steering wheel in both directions. Observe the steering cylinder for any leaks.

## HYDRAULICS

### TO REPLACE STEERING VALVE

1. Turn off the engine and engage the parking brake.

**FOR SAFETY: Before Leaving Or Servicing Machine; Stop On Level Surface, Set Parking Brake, Turn Off Machine And Remove Key.**

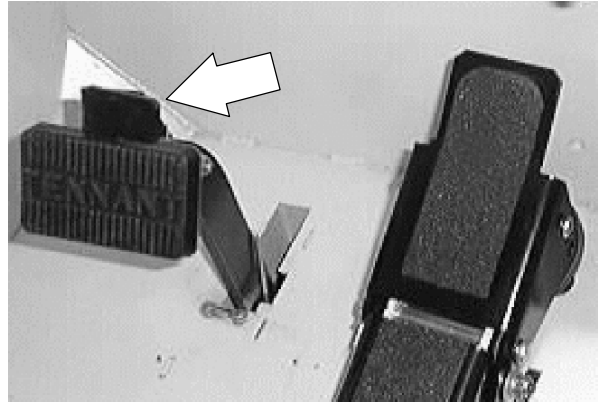

2. Open the engine cover.

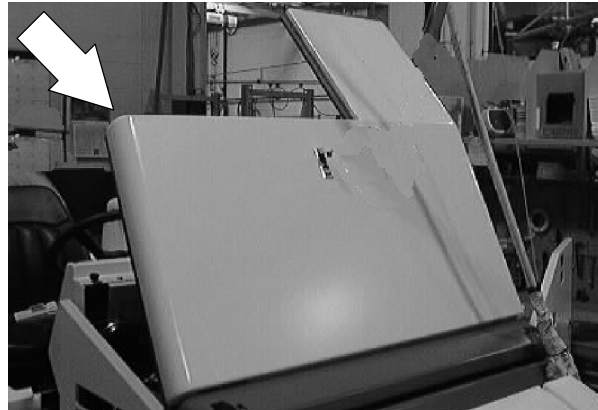

3. Remove battery cables from battery.

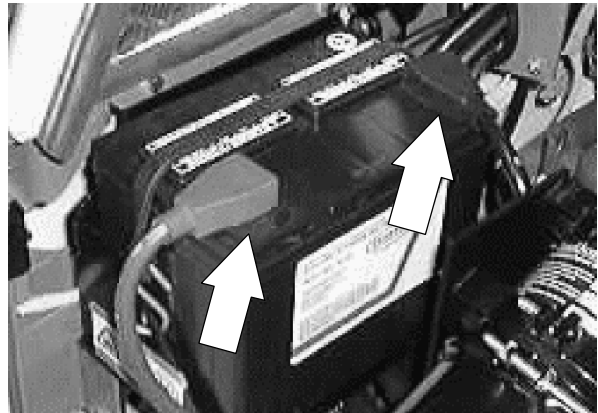

4. Tilt the steering wheel to the highest position.

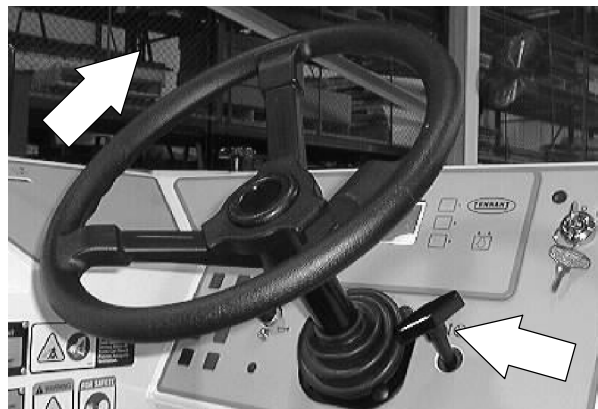



5. Mark, remove, and plug the five hydraulic hoses leading to the steering control valve.

*NOTE: Observe hydraulic cleanliness requirements when opening hydraulic lines.*

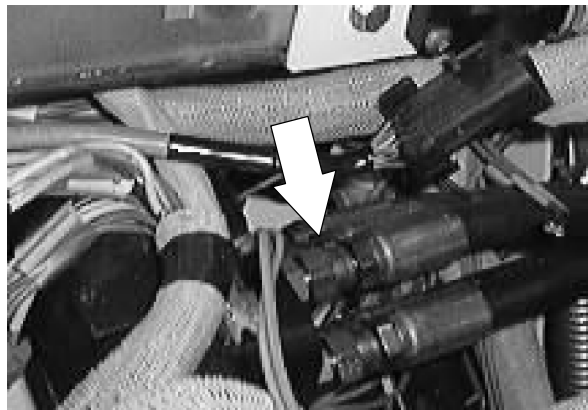

6. Remove the hex screws holding the hydraulic steering valve to the steering column.

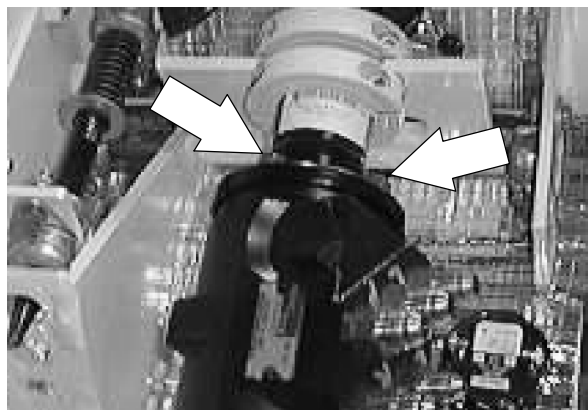

7. The hydraulic steering valve can now be removed from machine.



8. Remove the five hydraulic fittings from the old steering valve. Install the fittings in the new valve in the same orientation.



## HYDRAULICS

9. Install the new hydraulic steering valve in the machine. Position the ports in the same orientation as the old valve. Reinstall the hex screws and tighten to 31 - 40 Nm (27 - 35 ft lb).

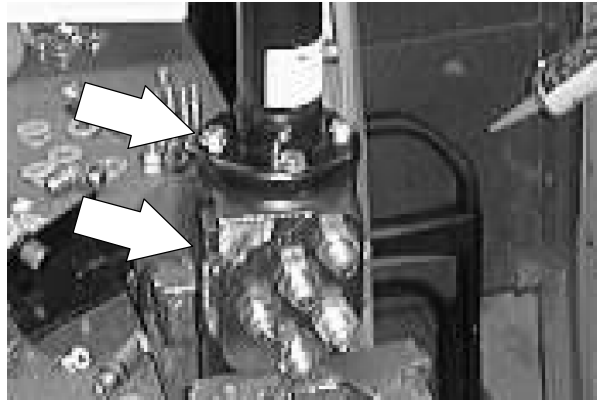

10. Reconnect the hydraulic hoses to hydraulic steering valve. See the schematic in this section.

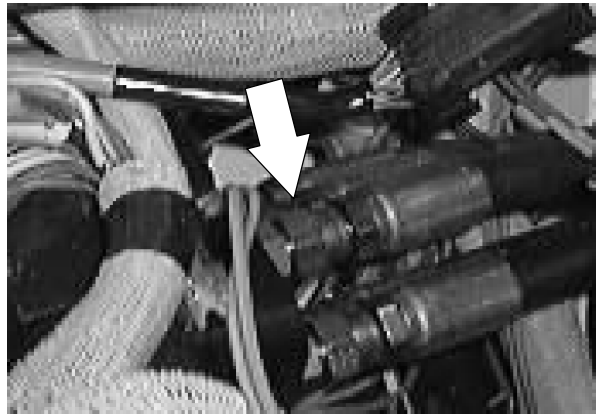

11. Reconnect the battery cables and start engine. Turn the steering wheel and check for any leaks.

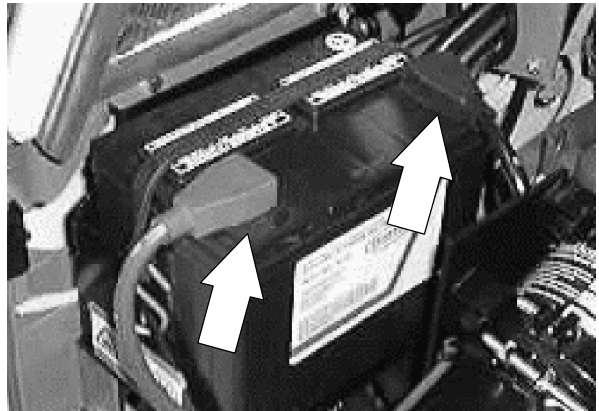

12. Close the engine side door and engine cover. Operate the machine and check for proper operation.



---

## HOPPER LIFT VALVE

---

The hopper lift valve is used to raise and lower the hopper and open and close the dump door on the standard machine. The hopper dump door is controlled with a solenoid valve on the 8210. The main and side brushes will only turn on when the hopper is in the down position.

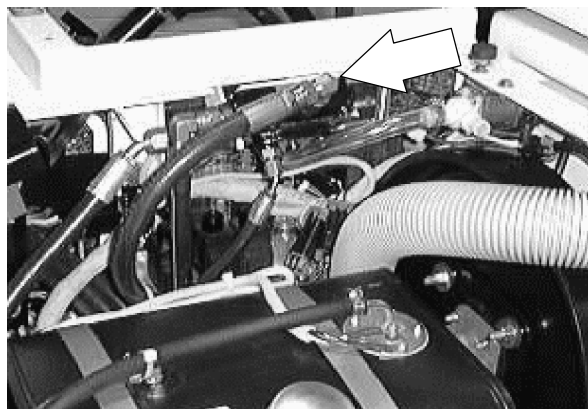

### TO REPLACE HOPPER LIFT VALVE

**FOR SAFETY: Before Leaving Or Servicing Machine; Stop On Level Surface, Set Parking Brake, Turn Off Machine And Remove Key.**

1. Open the engine cover and side door.

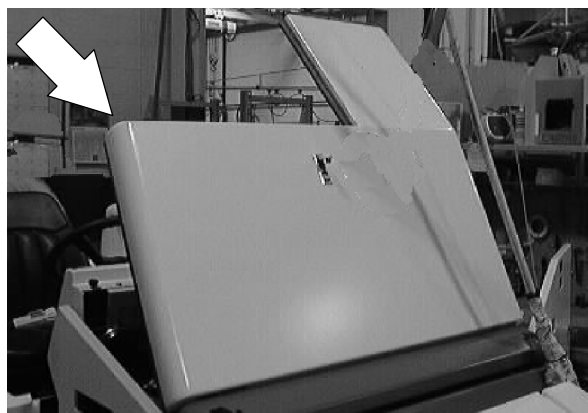

2. Disconnect the battery cables.

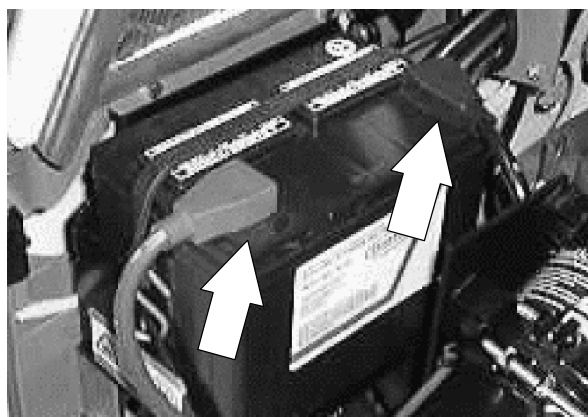

## HYDRAULICS

3. Locate the hopper lift valve on the top, inside of the operators compartment.

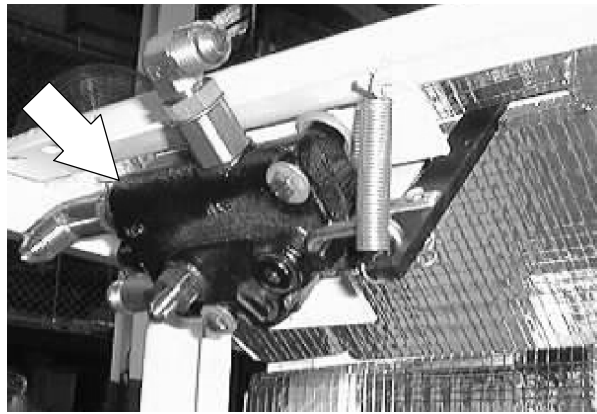

4. Mark, disconnect, and plug the hydraulic hoses leading to the hopper lift valve.

*NOTE: Observe hydraulic cleanliness requirements when opening hydraulic lines.*

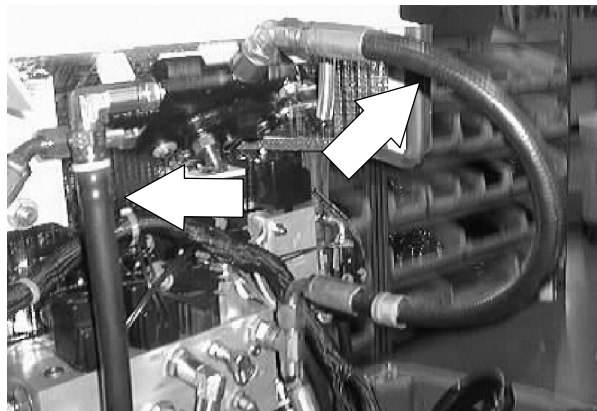

5. Remove the hair pins and clevis pins holding the handles to the lift valve. Remove the tension spring from the shorter handle.

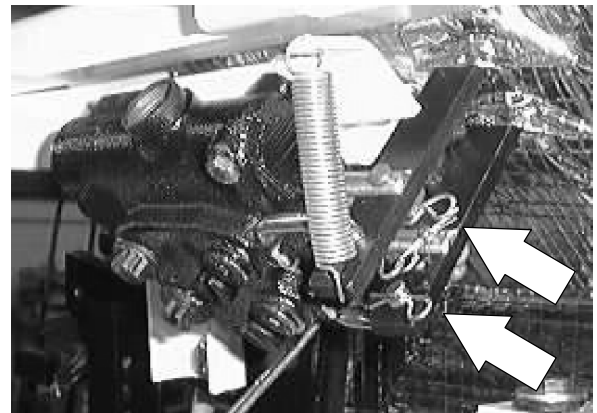

6. Remove the two M6 hex screws and nyloc nuts holding the lift valve to the lintel. Remove the valve from the machine.

*NOTE: Make sure to retain the two rubber washers located between the valve and lintel.*

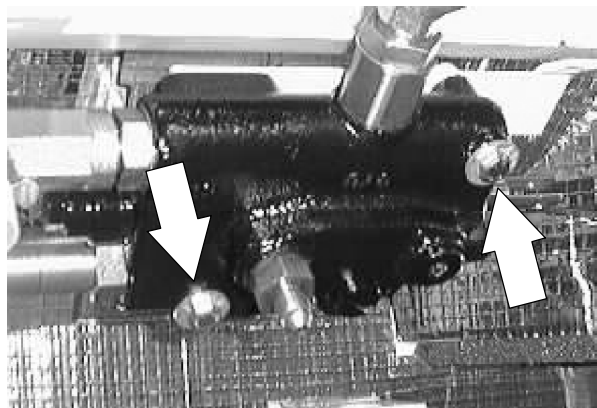

- Remove the fittings from the old valve and install in the new valve in the same orientation.

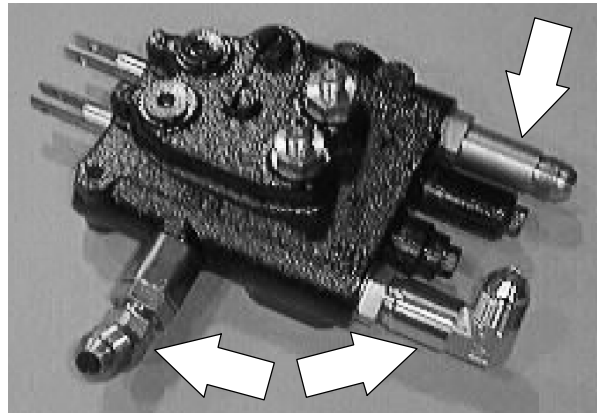

- Install the new valve back onto the inside wall of the lintel. Reinstall the two M6 hex screws, two rubber washers, and nyloc nuts. Tighten to 115 - 225 Ncm (10 - 20 in lb).

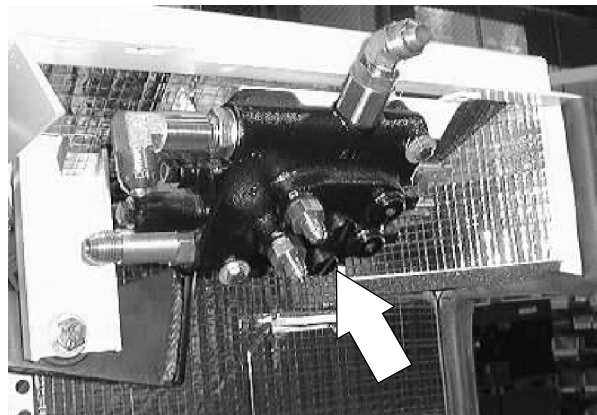

- Reconnect the hydraulic hoses. See hose diagram in this section.

*NOTE: Observe hydraulic cleanliness requirements when opening hydraulic lines.*

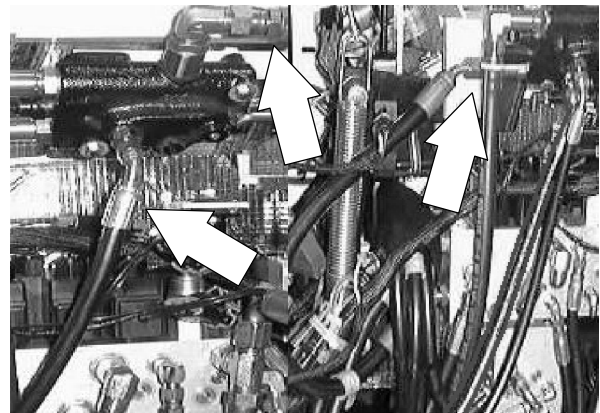

- Reinstall the two valve handles, clevis pins, and hair pins on the new valves. The link goes into the second hole on the handle.



## HYDRAULICS

11. Reconnect the tension spring to the shorter handle.



12. Reconnect the battery cables.
13. Start the machine and check the lift valve for any leaks.

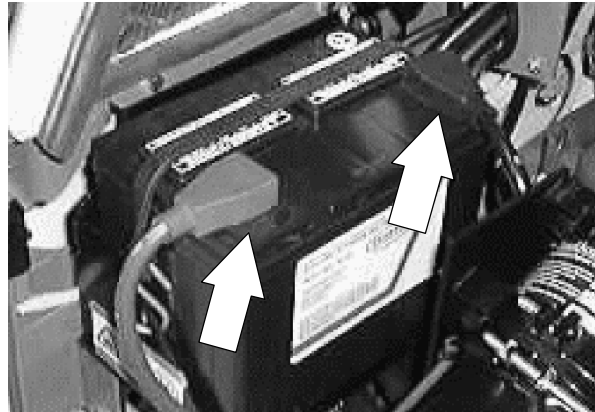

14. Close the engine side door and engine cover. Operate the machine and check for proper operation.

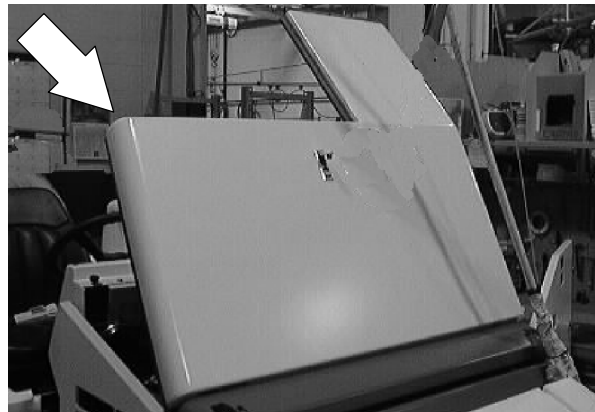

## HYDRAULIC SOLENOID VALVES

The hydraulic solenoid valves control the operation of the main and side brushes, vacuum fans, side shift option, and the side brush/main brush lift on the model 8210. The solenoid valve coils are electrically activated when the switches are activated on the touch panel. The solenoid valves also contain relief valves to protect the hydraulic system from damage.

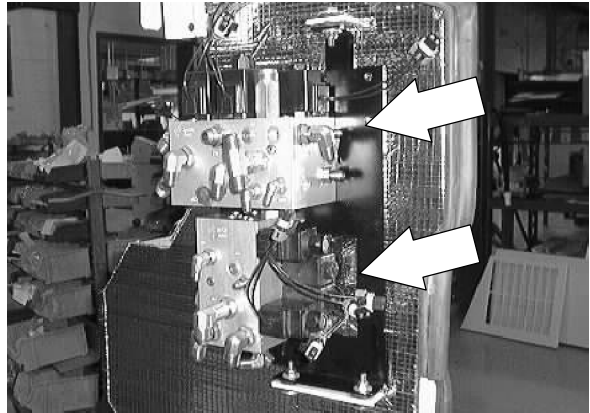

### TO REPLACE BRUSH AND VACUUM FAN SOLENOID VALVES

**FOR SAFETY: Before Leaving Or Servicing Machine; Stop On Level Surface, Set Parking Brake, Turn Off Machine And Remove Key.**

1. Open the engine cover and side door.



2. Disconnect the battery cables.

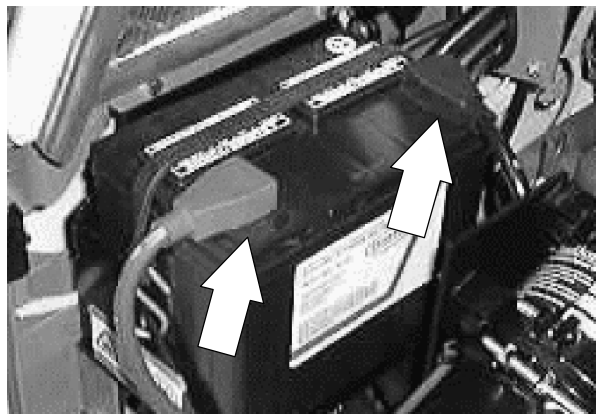

## HYDRAULICS

3. Remove the fuel tank or LP tank mount plate.

*NOTE: This will allow access to the solenoid valve assembly.*

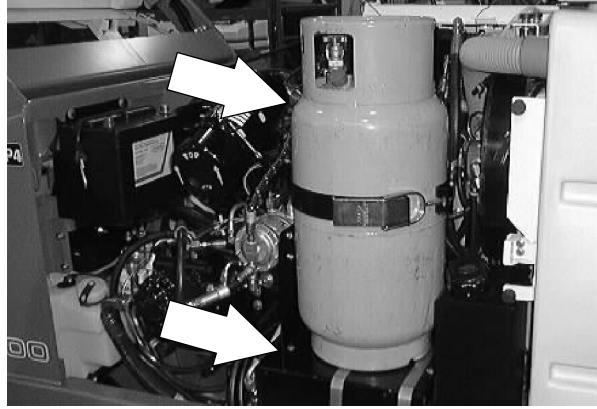

4. Locate the brush/vacuum fan solenoid valves on the lower/middle section of the operator compartment.

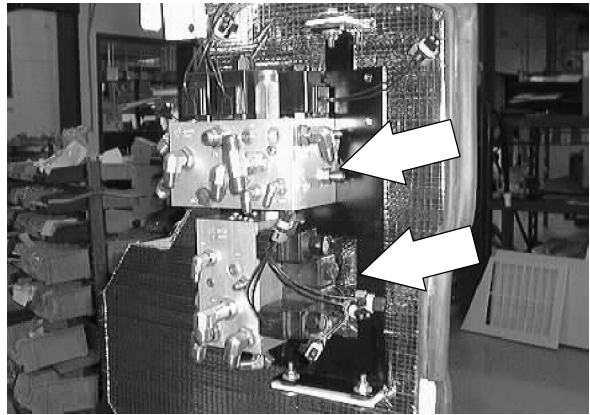

5. Mark, disconnect, and plug the hydraulic hoses leading to the brush/vacuum fan solenoid valve.

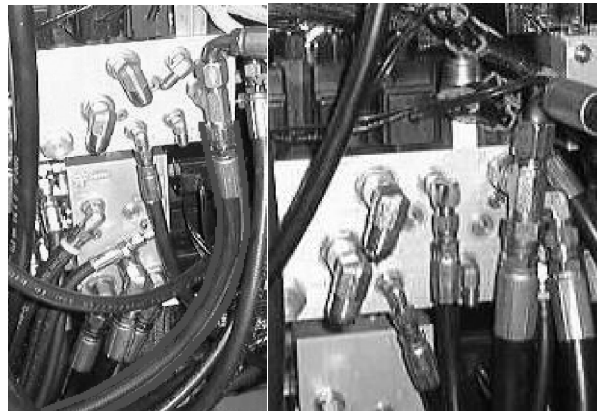

6. Un-plug the electrical coils from the main machine harness.

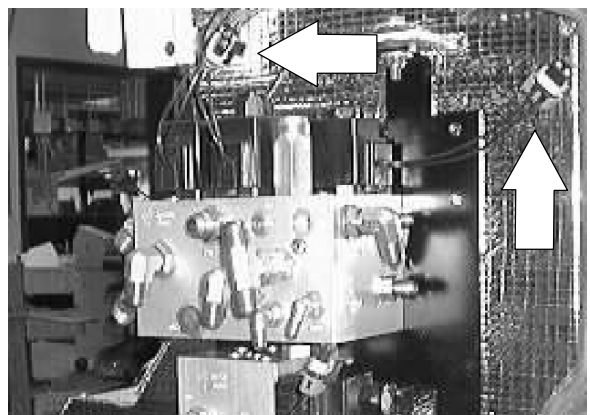



- Remove the three hex screws and nyloc nuts holding the valve mount plate to the operator compartment. Remove the valve and mount plate assembly from the machine.

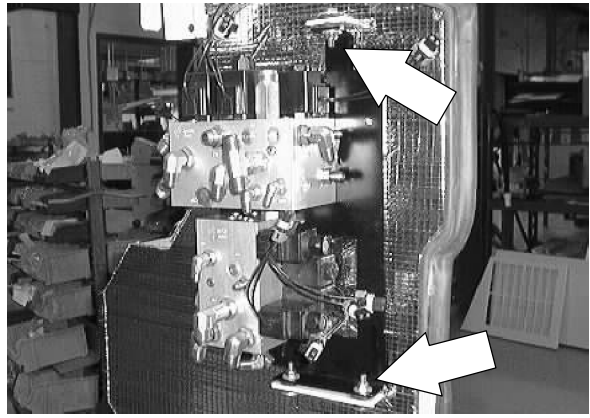

- Remove the seven hex screws holding the valves to the mount plate. Remove the valve from the plate.



- Remove the fittings from the old solenoid valves and install in the new valves in the same orientation.

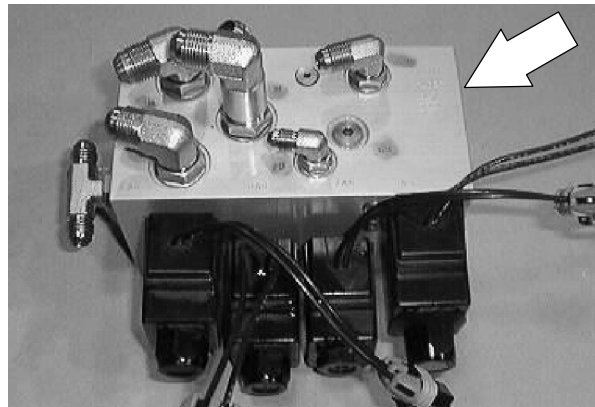

- Install the new valve onto the mount plate. Reinstall the seven hex screws and tighten to 18 - 24 Nm (15 - 20 ft lb).

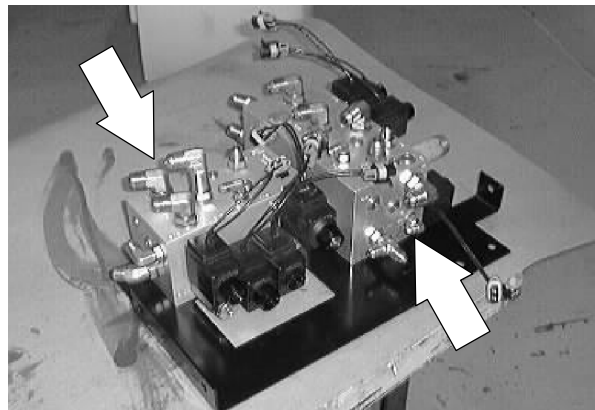

## HYDRAULICS

11. Install the new valves and mount plate on the inside wall of the operator compartment.
12. Reinstall the three hex screws and nyloc nuts and tighten to 18 - 24 Nm (15 - 20 ft lb).

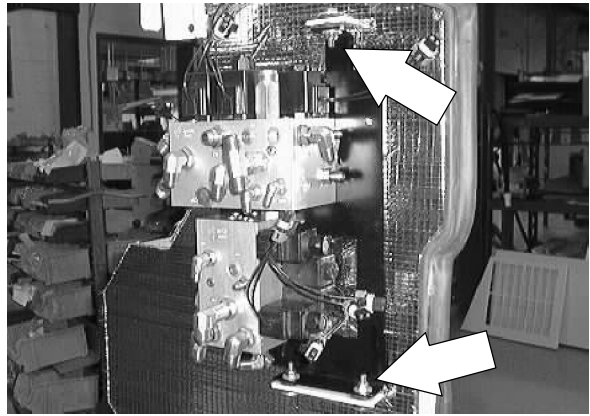

13. Reconnect the hydraulic hoses. See hose diagram in this section.

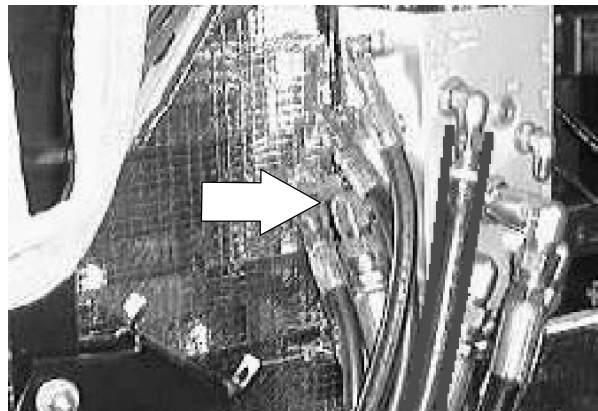

14. Reconnect the electrical coils to the main machine harness.

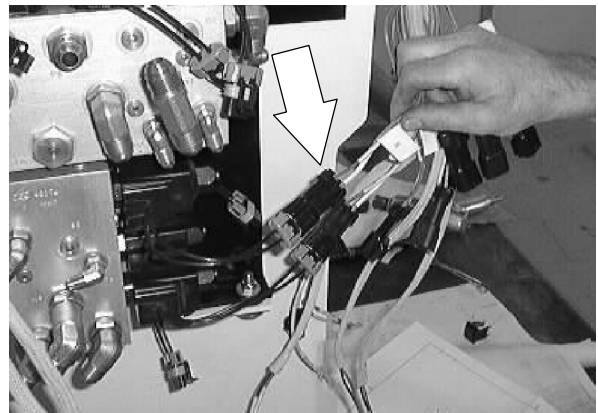

15. Reinstall the fuel tank or LP tank.

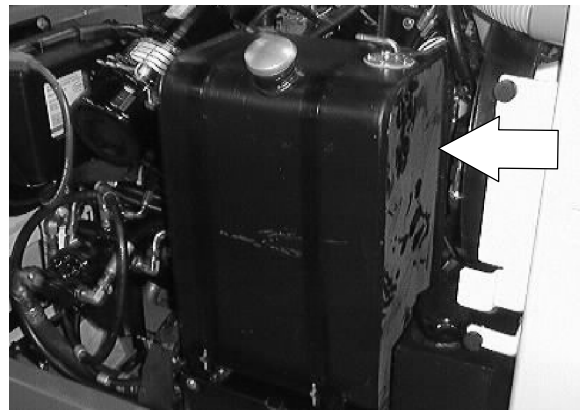

16. Reconnect the battery cables.
17. Start the machine and check the lift valve any leaks.

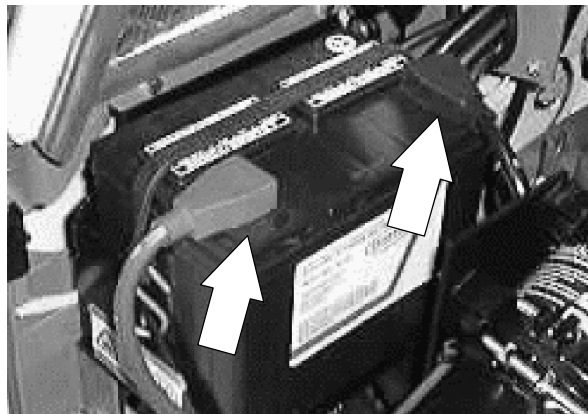

18. Close the engine side door and engine cover. Operate the machine and check for proper operation.



## HYDRAULICS

### TO REPLACE OPTIONAL SCRUB HEAD SIDE SHIFT SOLENOID VALVE (8210)

**FOR SAFETY: Before Leaving Or Servicing Machine; Stop On Level Surface, Set Parking Brake, Turn Off Machine And Remove Key.**

1. Open the engine cover and side door.

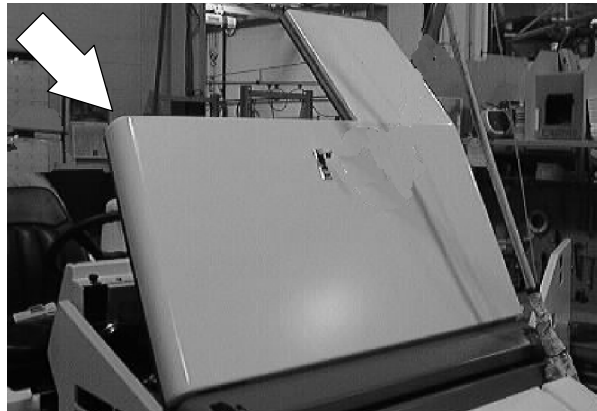

2. Disconnect the battery cables.

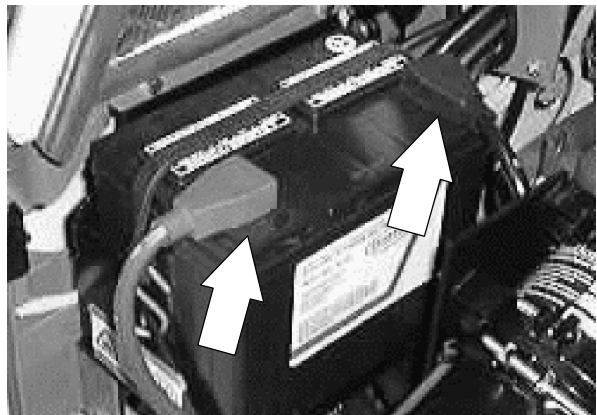

3. Remove the fuel tank or LP tank mount plate.

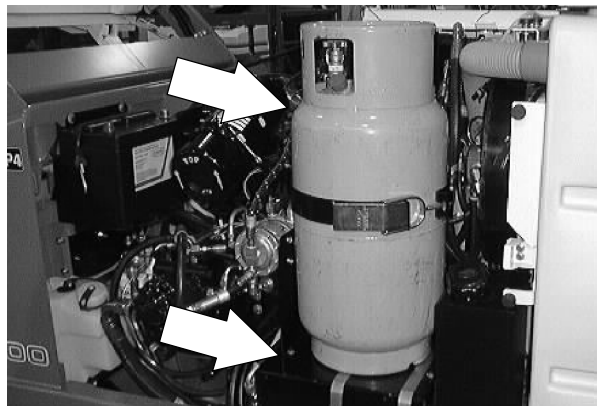

4. Locate the scrub head side shift solenoid valve on the lower/middle section of the operator compartment.

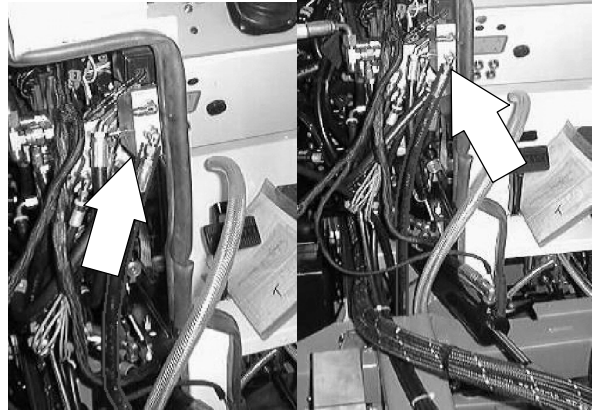

5. Mark, disconnect, and plug the hydraulic hoses leading to the side shift solenoid valve.

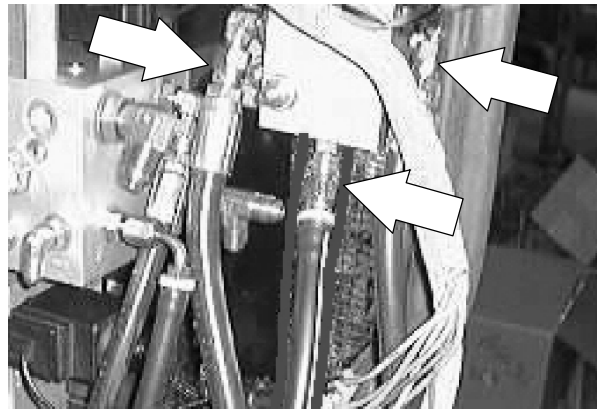

6. Un-plug the electrical coils from the main machine harness.

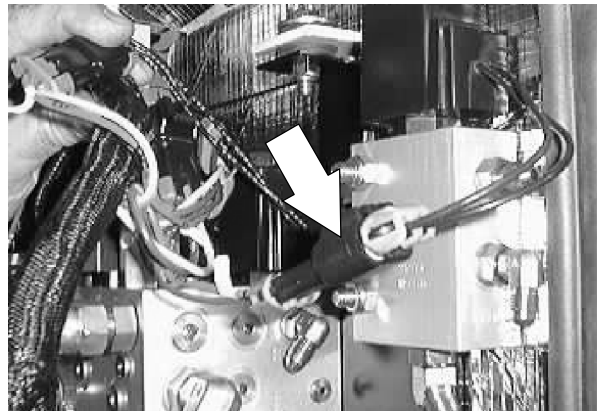

7. Remove the two hex screws and nyloc nuts holding the valve to the mount plate. Remove the valve from the plate.



## HYDRAULICS

8. Remove the fittings from the old solenoid valves and install in the new valve in the same orientation.

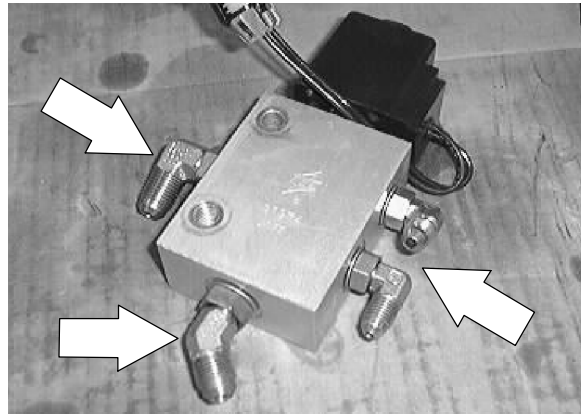

9. Install the new valve onto the mount plate. Reinstall the two hex screws and nuts. Tighten to 18 - 24 Nm (15 - 20 ft lb).

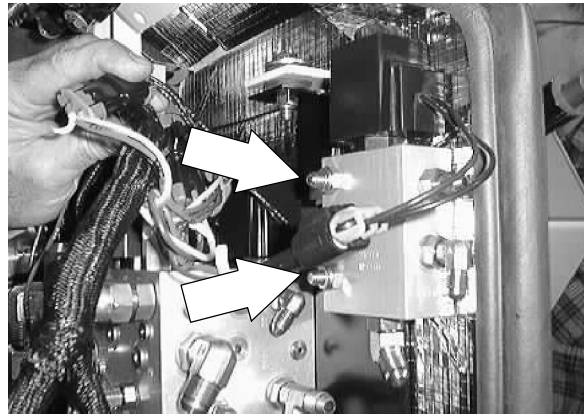

10. Reconnect the hydraulic hoses. See hose diagram in this section.

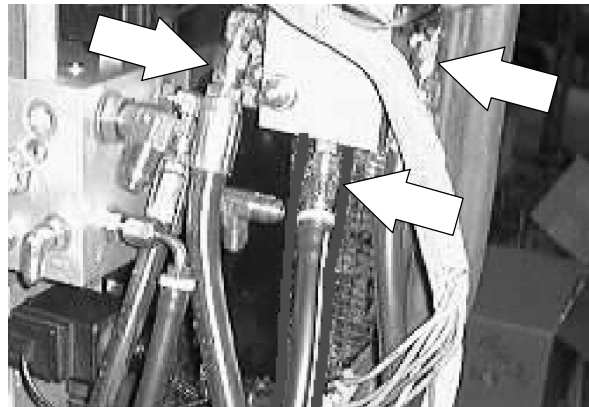

11. Reconnect the electrical coils to the main machine harness.

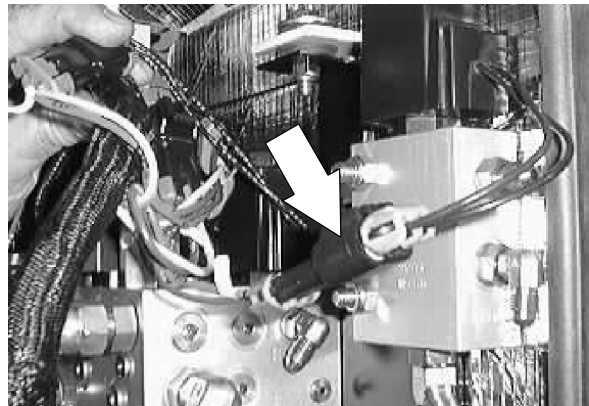

12. Reinstall the fuel tank or LP tank. Reconnect the battery cables.

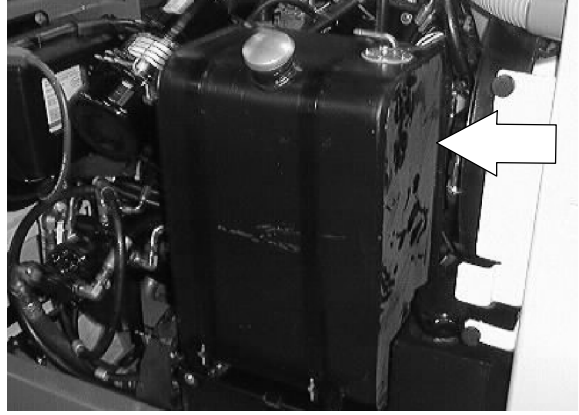

13. Reconnect the battery cables.
14. Start the machine and check the side shift valve any leaks.

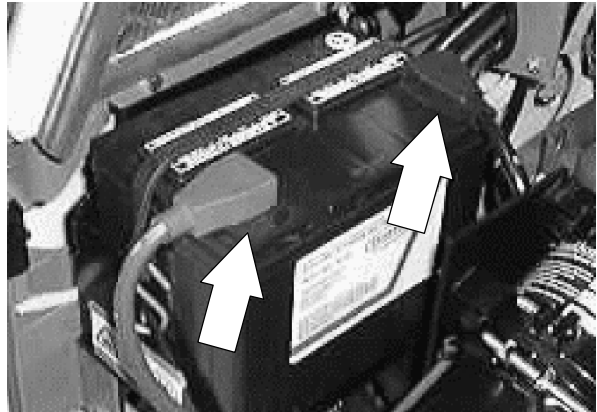

15. Close the engine side door and engine cover. Operate the machine and check for proper operation.



## HYDRAULICS

### TO REPLACE SIDE BRUSH/MAIN BRUSH LIFT, HOPPER DOOR OPEN/CLOSE SOLENOID VALVE (8210)

**FOR SAFETY: Before Leaving Or  
Servicing Machine; Stop On Level  
Surface, Set Parking Brake, Turn Off  
Machine And Remove Key.**

1. Open the engine cover and side door.



2. Disconnect the battery cables.

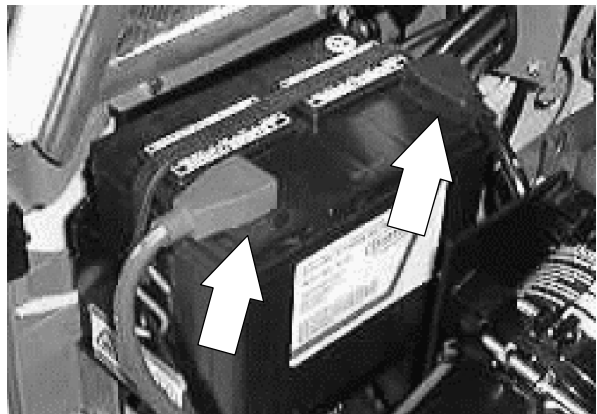

3. Locate the solenoid valve at the upper/front outside corner of the operator compartment.





4. Un-plug the electrical coils from the main machine harness.

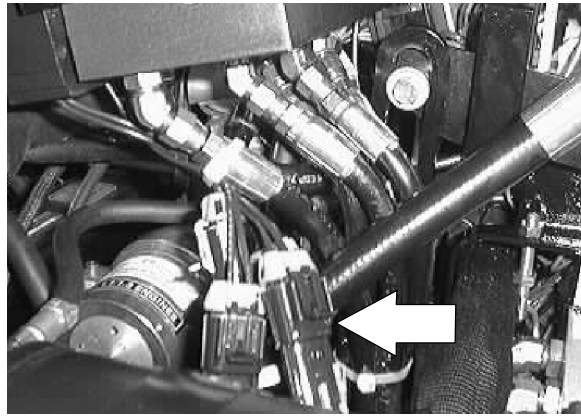

5. Mark, disconnect, and plug the hydraulic hoses leading to the solenoid valve.

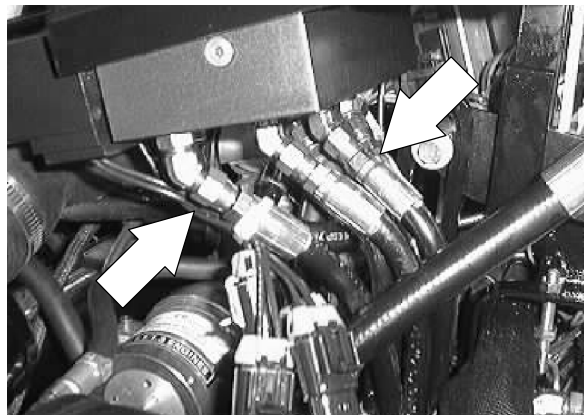

6. Remove the two hex screws and nyloc nuts holding the valve to the mount bracket.

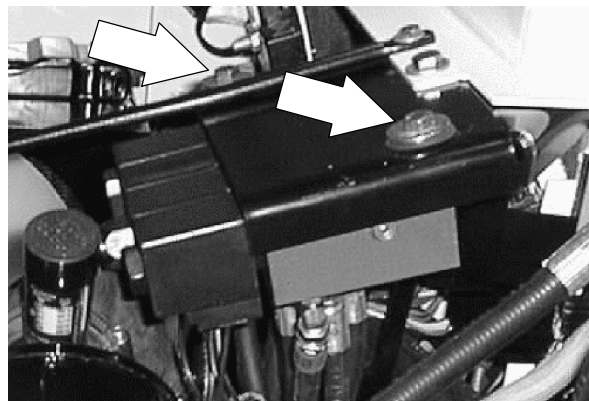

7. Remove the fittings from the old solenoid valve and install in the new valve in the same orientation.

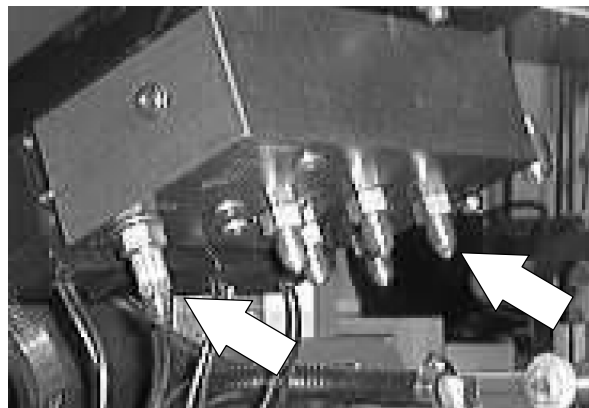

## HYDRAULICS

8. Install the new valve onto the mount plate. Reinstall the two hex screws and tighten to 18 - 24 Nm (15 - 20 ft lb).

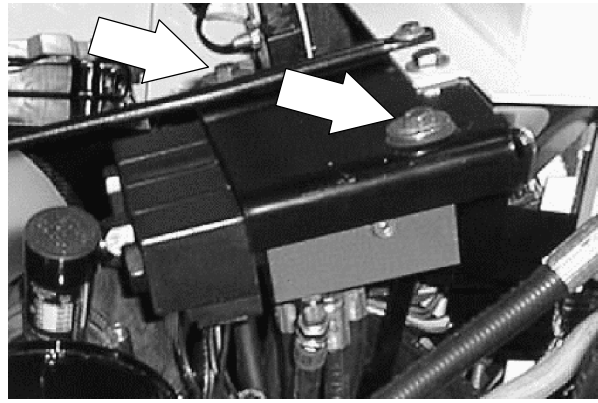

9. Reconnect the hydraulic hoses. See hose diagram in this section.

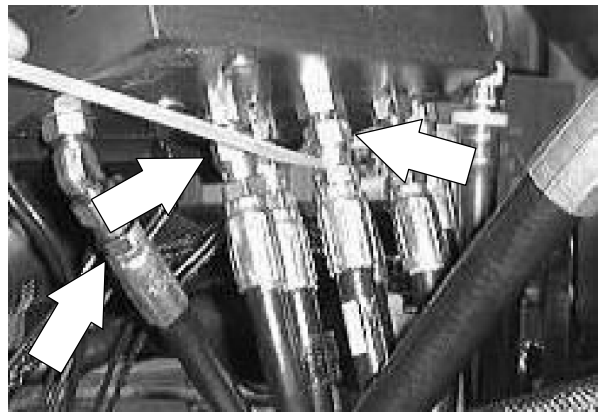

10. Reconnect the electrical coils to the main machine harness.

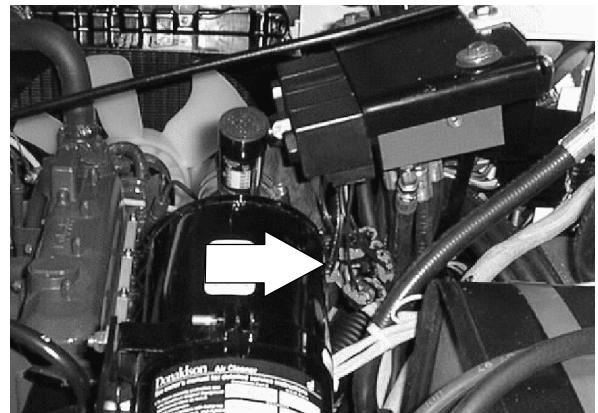

11. Reconnect the battery cables.

12. Start the machine and check the brush lift valve for any leaks.

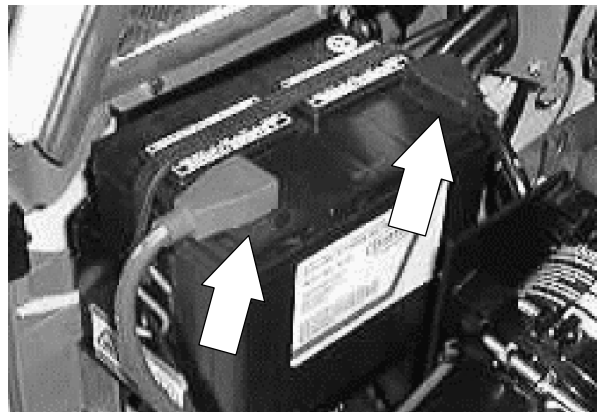

13. Close the engine side door and engine cover. Operate the machine and check for proper operation.

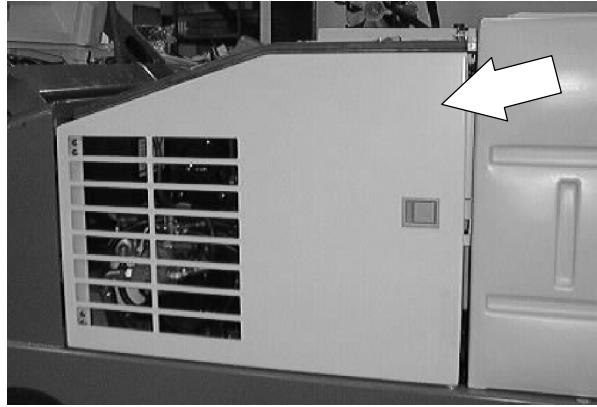

## HYDRAULICS

### TO REPLACE MAIN SWEEPING BRUSH MOTOR

1. Raise the hopper and engage the support bar.



**WARNING:** Raised Hopper May Fall. Engage Hopper Support Bar.

**FOR SAFETY:** Before Leaving Or Servicing Machine; Stop On Level Surface, Set Parking Brake, Turn Off Machine And Remove Key.

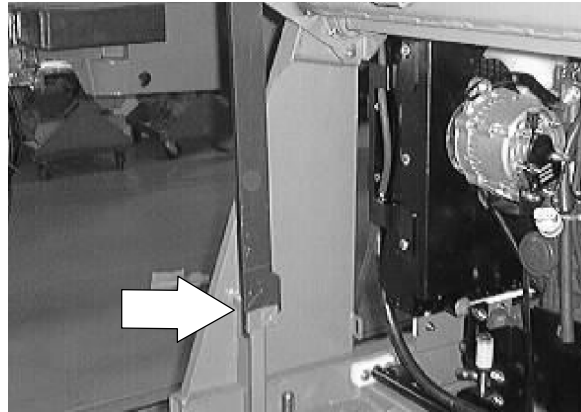

2. Remove the main brush from the machine.

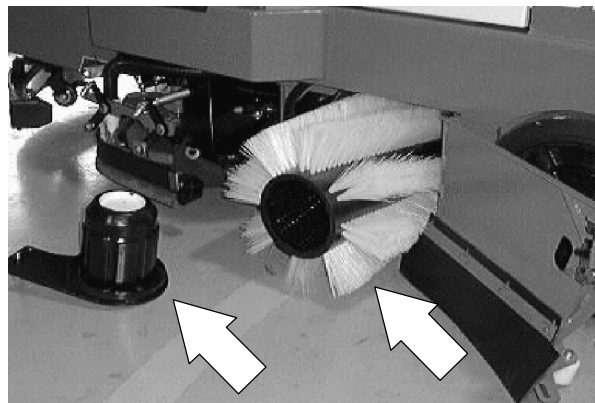

3. Remove the hex screws holding the left side main brush door to the machine. Remove the door from the machine.

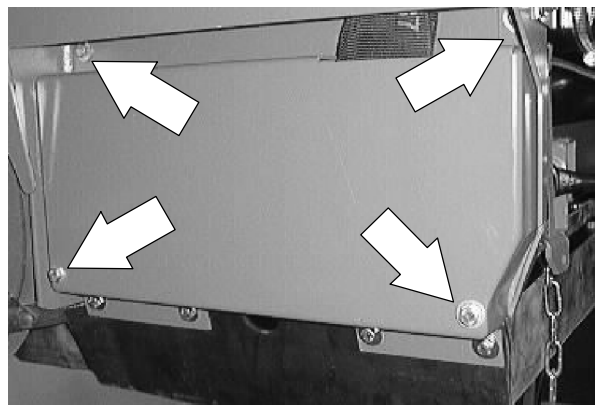

4. Mark, remove, and plug the hydraulic hoses leading to the main brush motor. Remove the hose clamp from the brush arm.

*NOTE: Observe hydraulic cleanliness requirements when opening hydraulic lines.*

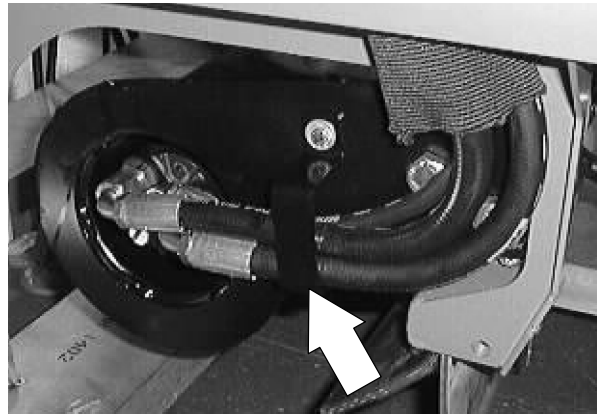

5. Remove the hex screw holding the brush arm and motor to the machine. Remove the brush arm and motor.

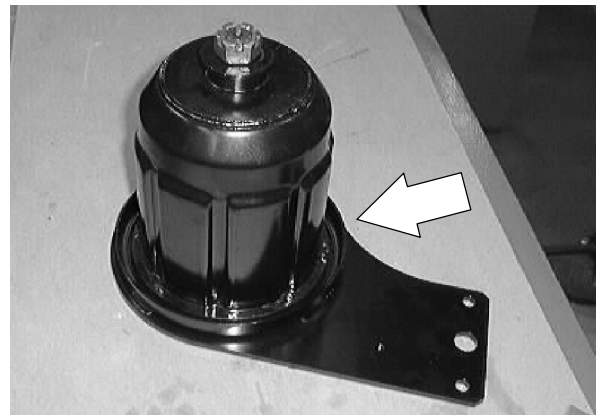

6. Remove the cotter pin from castle nut at the end of main brush drive motor plug.



7. Hold the brush drive plug from turning and remove the castle nut.

8. A puller must be used to remove the brush drive plug from tapered shaft on the main brush motor.

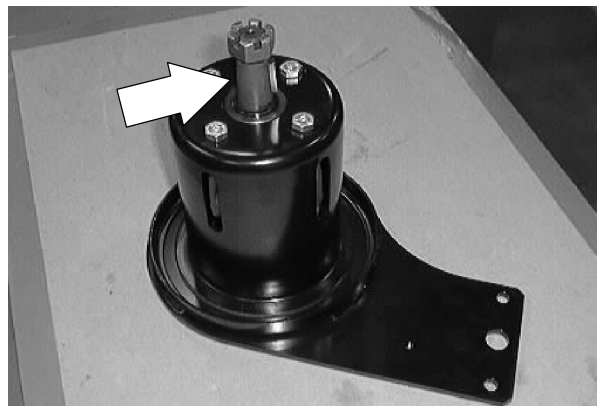

## HYDRAULICS

9. Remove the four hex screws holding the main brush motor to the brush arm. Remove the motor from the machine.

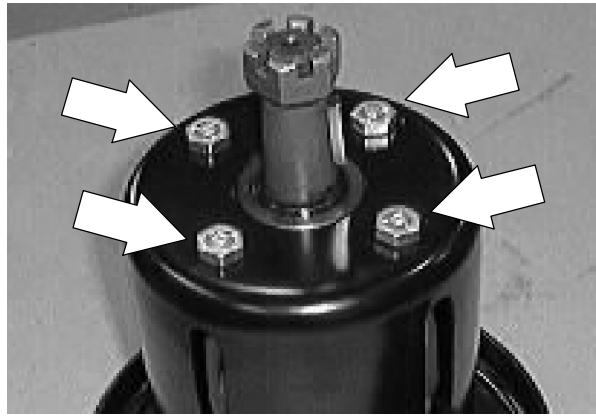

10. Remove the hydraulic fittings from old motor and install in the new motor in the same orientation.

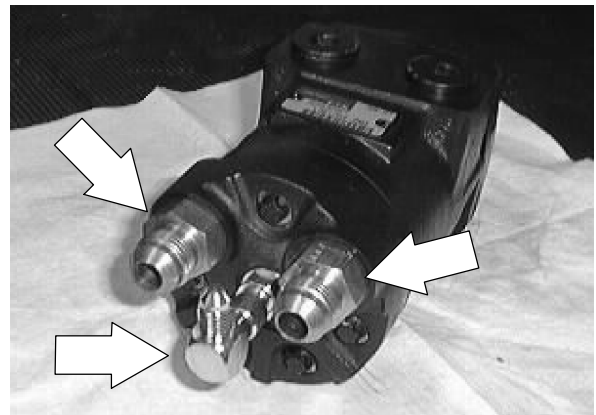

11. Install the new main brush motor in the brush arm. Tighten the hex screws to (27 - 53 ft lb).

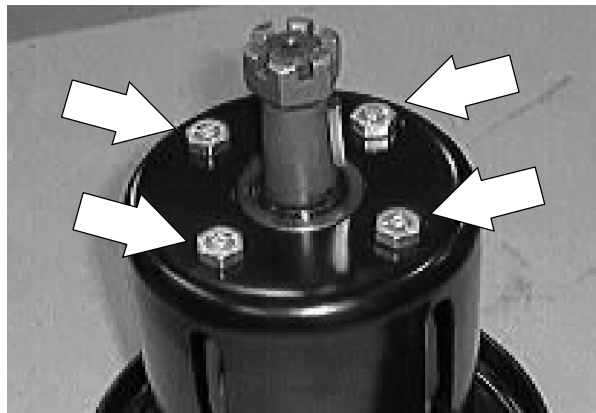

12. Reinstall the brush drive plug back on the tapered shaft of the new motor. Make sure the key is in place.

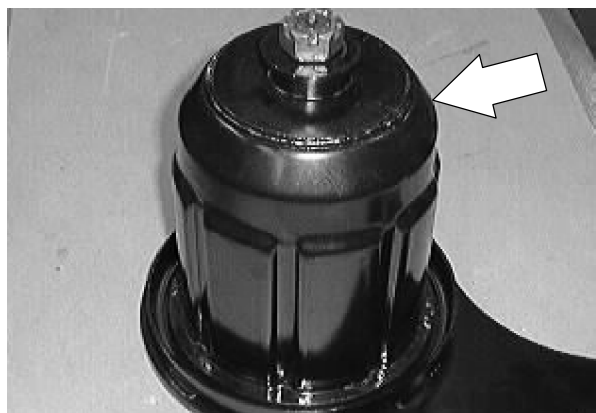

13. Reinstall the castle nut and tighten to 40 - 54 Nm (30 - 40 ft lb). Continue to tighten castle nut until it lines up with hole in brush motor shaft. Install a new cotter pin.

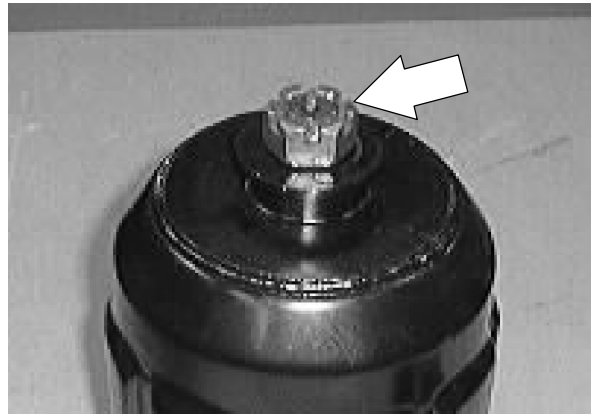

14. Reinstall the brush arm and motor onto the brush shaft. Tighten the hex screw to 163 - 190 Nm (120 - 140 ft lb).



15. Reconnect the hydraulic hoses to the new motor. Reinstall the hose clamp. See schematic in this section.

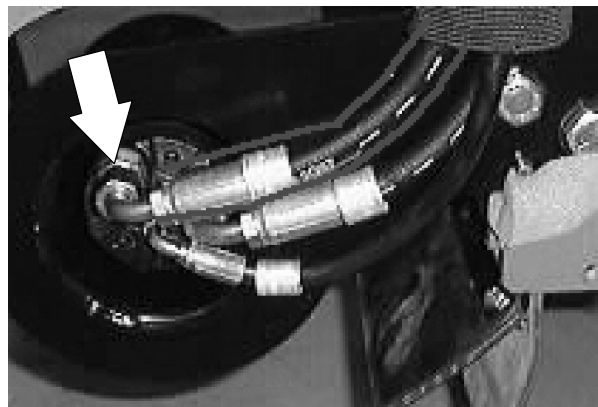

16. Reinstall the left hand door and skirt. Tighten the hex screws to 18 - 24 Nm (15 - 20 ft lb).

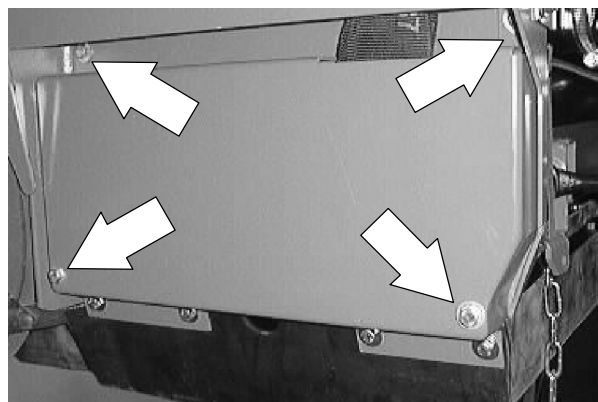

17. Reinstall the main brush. Operate the machine and check for proper operation.

## HYDRAULICS

### TO REPLACE SIDE BRUSH MOTOR

1. Empty the debris hopper.

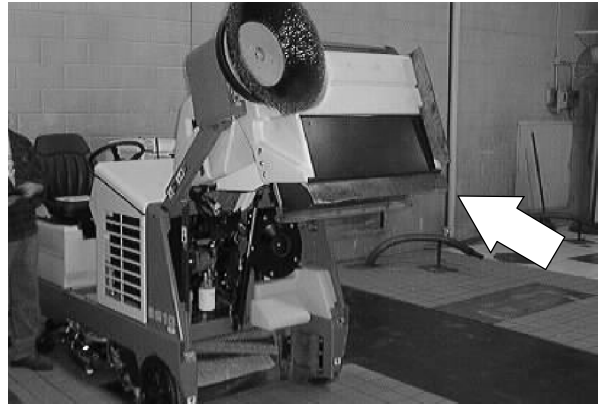

2. Set the machine parking brake.

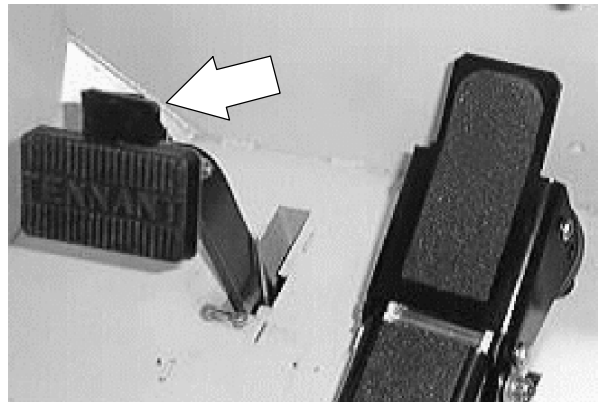

3. Raise the hopper and engage the support bar.

 **WARNING: Raised Hopper May Fall. Engage Hopper Support Bar.**

**FOR SAFETY: Before Leaving Or Servicing Machine; Stop On Level Surface, Set Parking Brake, Turn Off Machine And Remove Key.**

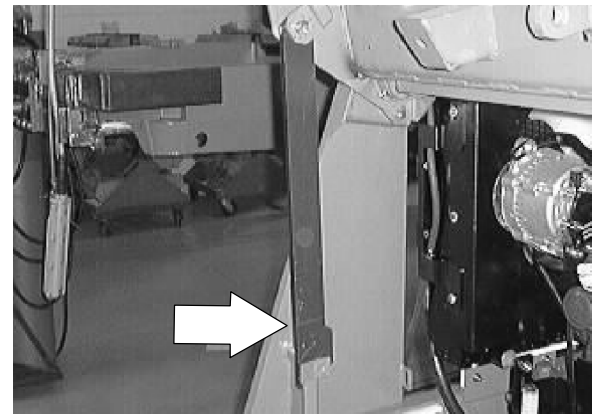

4. Remove the side brush retaining pin from the side brush drive shaft by pulling the pin keeper over the end of the pin. Remove the side brush from the side brush motor.





5. Mark, remove, and plug the hydraulic hoses leading to the side brush motor.

*NOTE: Observe hydraulic cleanliness requirements when opening hydraulic lines.*

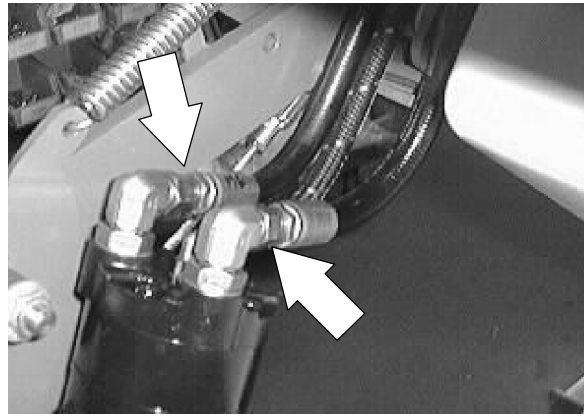

6. Remove the four hex screws holding the side brush motor to the mount bracket. Remove the side brush guard and side brush motor from machine.

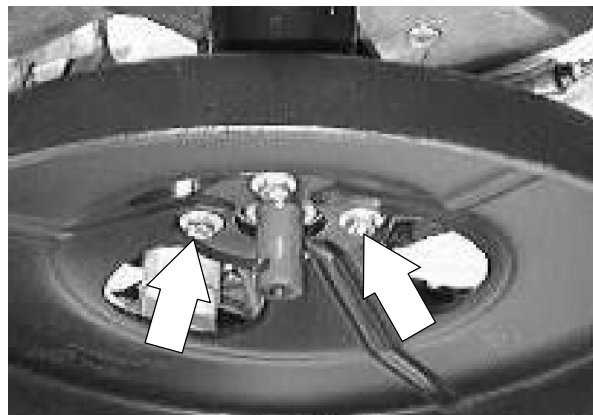

7. Remove the hydraulic fittings from the old motor and install in the new motor in the same orientation.

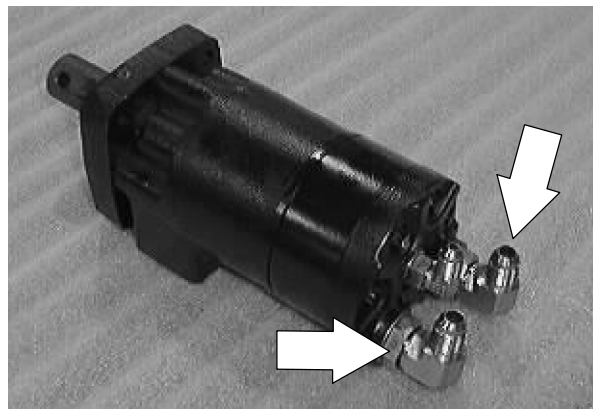

8. Install the new side brush motor and the side brush guard on the mount bracket. Tighten the four hex screws to (27 - 35 ft lb).



## HYDRAULICS

9. Reconnect the hydraulic hoses to the side brush motor. See hose diagram in this section.

*NOTE: Check the orientation of the hydraulic fittings in the motor so that the hoses do not rub on the lift arms when the side brush is raised and lowered.*

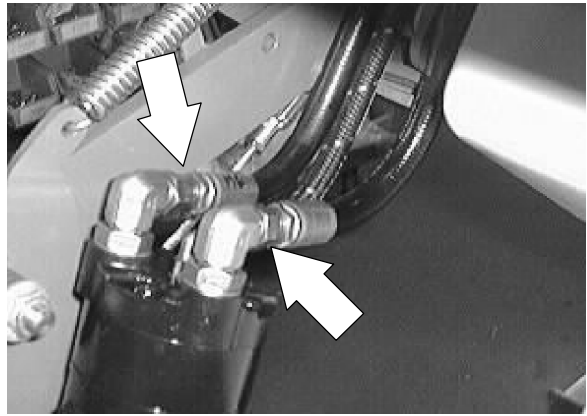

10. Reinstall the side brush on the side brush motor.
11. Reinstall the side brush retaining pin through the side brush hub and shaft.
12. Secure the pin by clipping the pin keeper over the end of the pin.

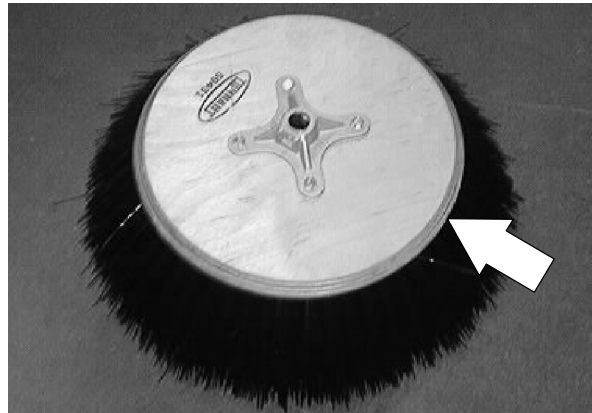

13. Disengage the hopper support bar and lower the hopper.



14. Adjust the side brush pattern with the side brush down pressure lever.

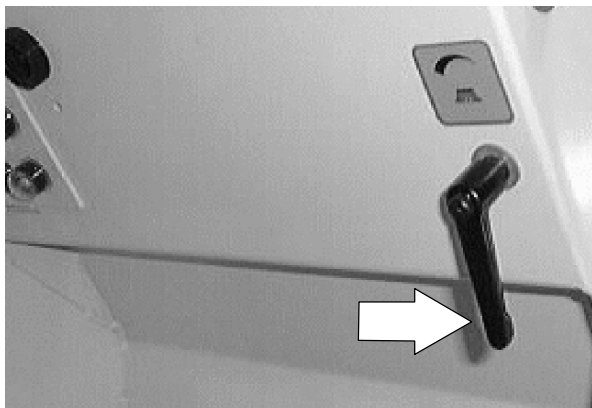

**TO REPLACE SCRUB BRUSH MOTOR**

**FOR SAFETY: Before Leaving Or Servicing Machine; Stop On Level Surface, Set Parking Brake, Turn Off Machine And Remove Key.**

1. Remove the scrub brush from the motor that needs changing.

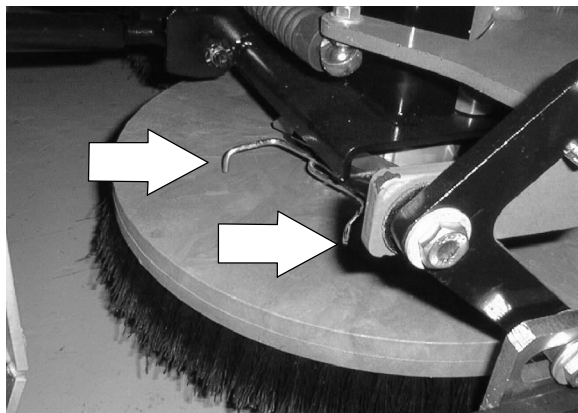

2. Remove the side squeegee from the side of the scrub head nearest the motor that needs changing.

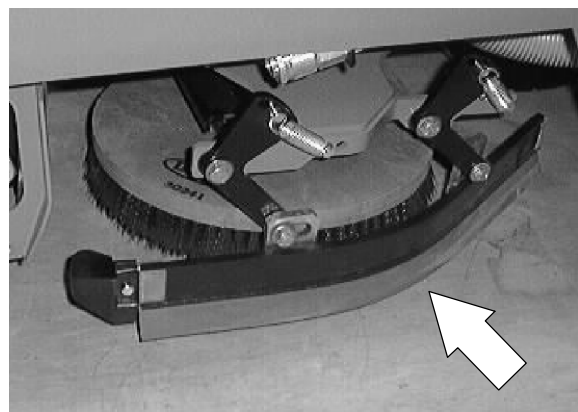

3. Mark, remove, and plug the hydraulic hoses leading to the scrub brush motor.

*NOTE: Observe hydraulic cleanliness requirements when opening hydraulic lines.*

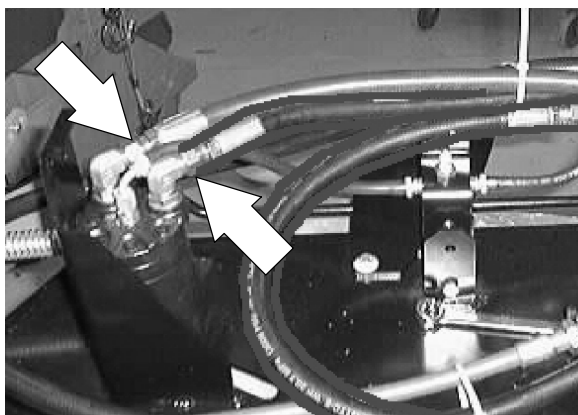

## HYDRAULICS

4. Remove the hex screw and two spacers holding the scrub brush drive plug to the scrub brush motor.

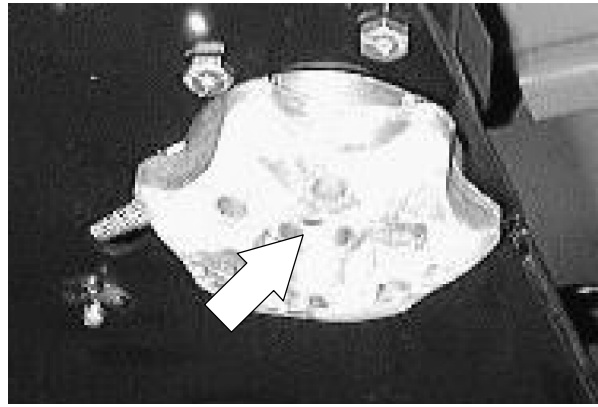

5. Pull the drive plug down and off the scrub brush motor.

*NOTE: The drive plug may need to be pried off with a crow bar or large screw driver.*

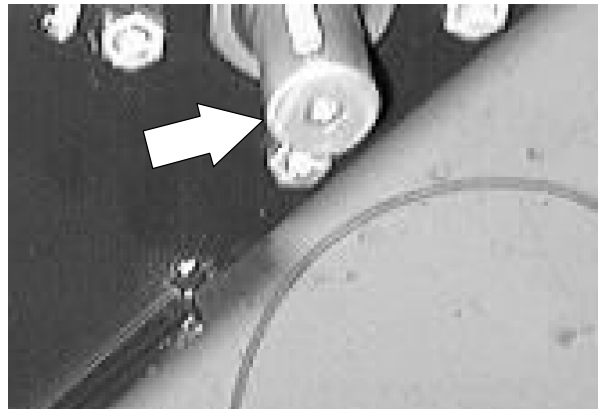

6. Remove the four hex screws holding the scrub brush motor to the scrub head. Remove the motor from the head. Note the orientation of the motor fittings.

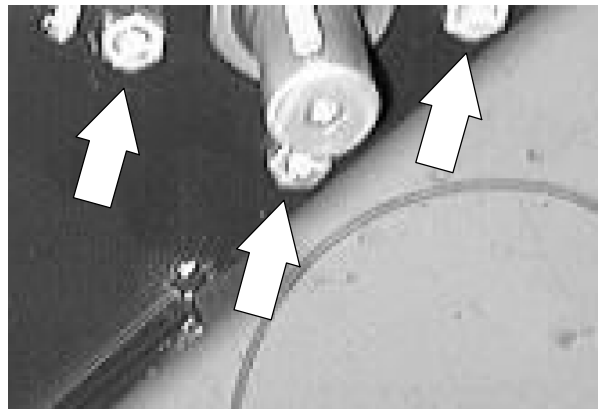

7. Remove the hydraulic fittings from the old motor and install in the new motor in the same orientation.

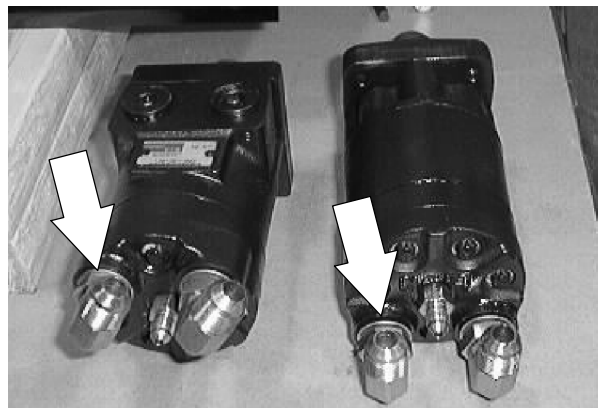

8. Install the new scrub brush motor onto the scrub head. Tighten the four hex screws to (27 - 35 ft lb).

*NOTE: Note the orientation of the motor fittings.*

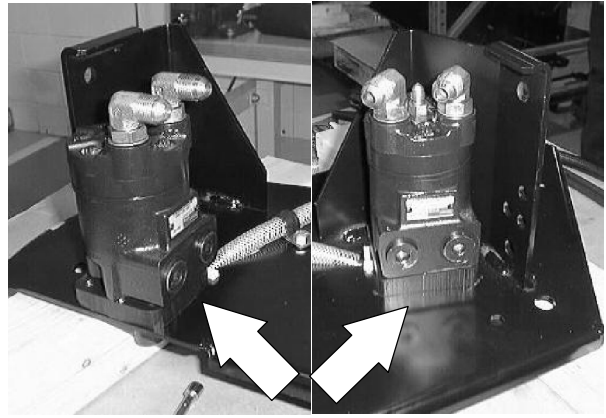

9. Reconnect the hydraulic hoses to the side brush motor. See hose diagram in this section.

*NOTE: Reinstall any plastic clamps or ties.*

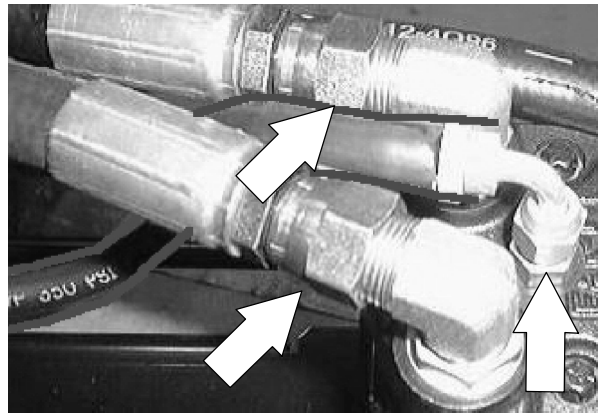

10. Reinstall the drive plug, two washers, and hex screw. Tighten to 11 - 14 Nm (7 - 10 ft lb). Make sure the square key is in place on the motor shaft.

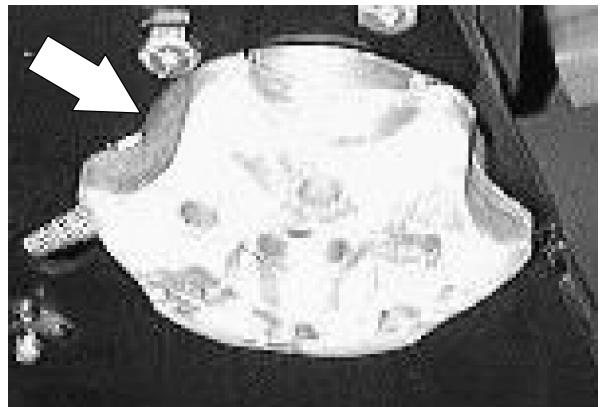

11. Reinstall the scrub brush and side squeegee assembly.



12. Operate the machine and check the scrub head for proper operation.

### TO REPLACE SWEEPING VACUUM FAN MOTOR

**FOR SAFETY: Before Leaving Or Servicing Machine; Stop On Level Surface, Set Parking Brake, Turn Off Machine And Remove Key.**

1. Remove the sweeping vacuum fan assembly from the machine. See TO REMOVE SWEEPING VACUUM FAN ASSEMBLY instructions in the SWEEPING section.

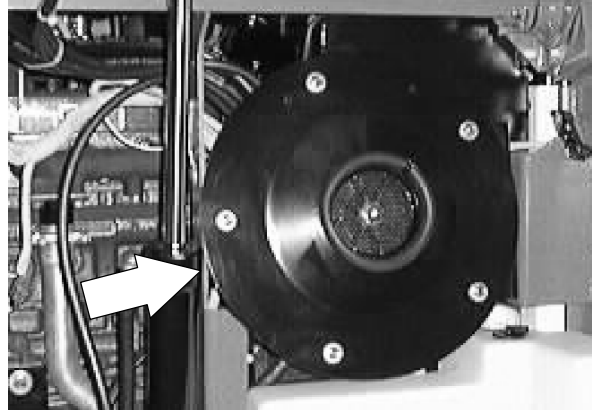

2. Remove the three hex screws, washers, and nyloc nuts holding the inlet plate to the vacuum fan assembly. Lift the inlet plate off the backing plate.

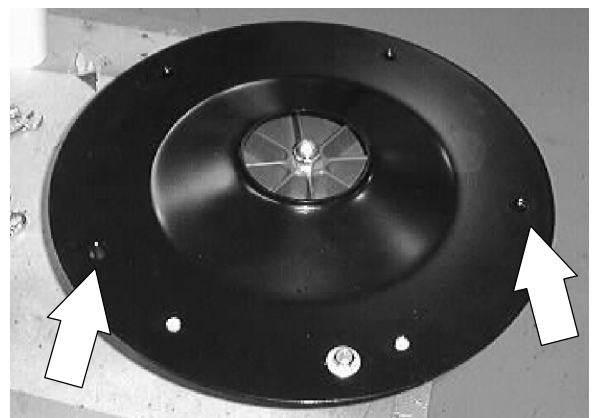

3. Remove the flex lock nut from the center of the fan impeller. Pull the fan impeller straight up and off the vacuum fan hydraulic motor. Make sure to retain the square key.

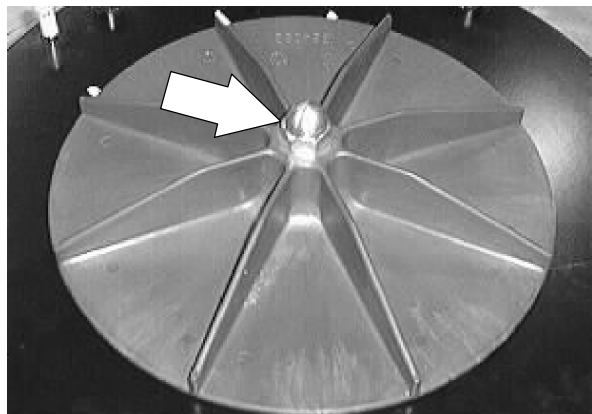

4. Remove the four flat screws, washers, and nyloc nuts holding the fan motor mount plate to the vacuum plate.

*NOTE: Note the orientation of the hydraulic motor fittings to the pins on the vacuum plate.*

5. Remove the motor and mount plate assembly.

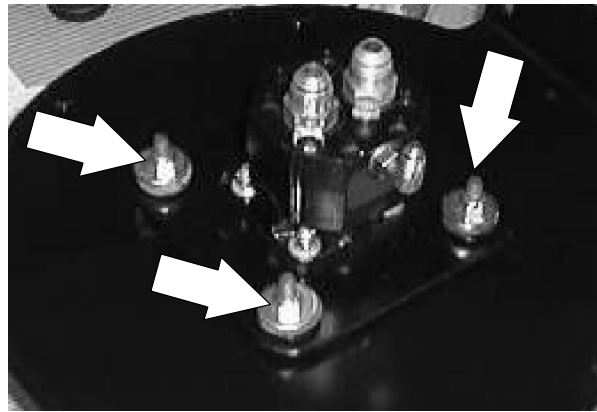

6. Remove the four flat screws, washers, and nyloc nuts holding the fan motor to the mount plate. Remove the motor.

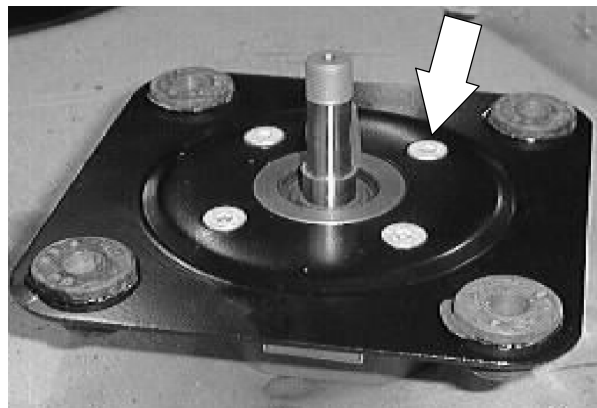

7. Remove the hydraulic fittings from the old motor and install in the new motor in the same orientation.

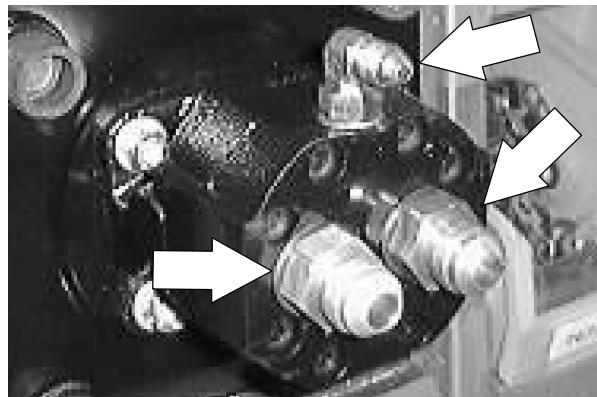

8. Install the new fan motor onto the mount plate. Install the four flat screws, washers, and nyloc nuts. Tighten to 11 - 14 Nm (7 - 10 ft lbs).

*NOTE: The motor can be installed on the mount plate in any orientation.*

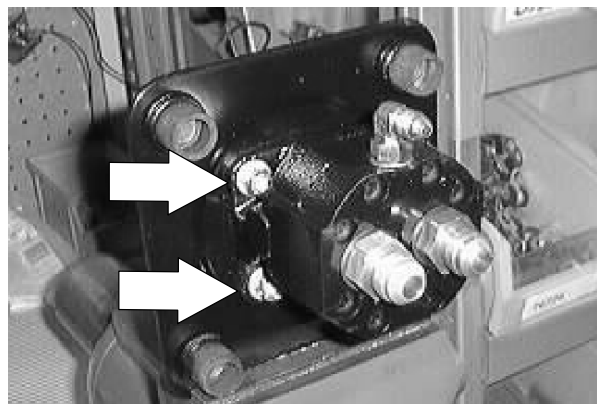

## HYDRAULICS

9. Install the fan and mount plate assembly onto the vacuum plate.

*NOTE: Note the orientation of the hydraulic motor fittings to the pins on the vacuum plate.*

10. Install the four flat screws, washers, and nyloc nuts. Tighten to 18 - 24 Nm (15 - 20 ft lbs).



11. Install the impeller onto the vacuum fan hydraulic motor shaft.

*NOTE: Make sure the square key is in place on the motor shaft.*

Install the flex lock nut. Use a small amount of blue loctite 242 on the threads. Tighten to 37 - 48 Nm (26 - 34 ft lbs).

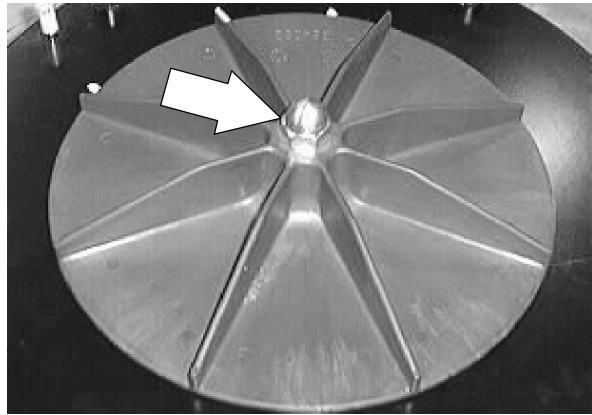

12. Install the inlet plate onto the vacuum plate assembly.

*NOTE: The inlet plate can only be installed one way.*

13. Install the three hex screws, washers, and nyloc nuts. Tighten to 18 - 24 Nm (15 - 20 ft lbs).

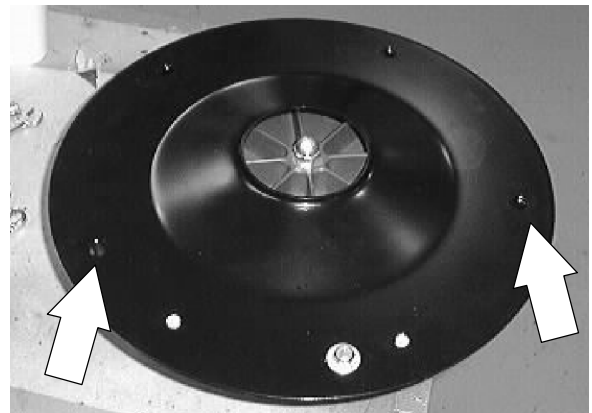

14. Reinstall the sweeping vacuum fan assembly into the machine. See TO INSTALL SWEEPING VACUUM FAN ASSEMBLY instructions in the SWEEPING section.

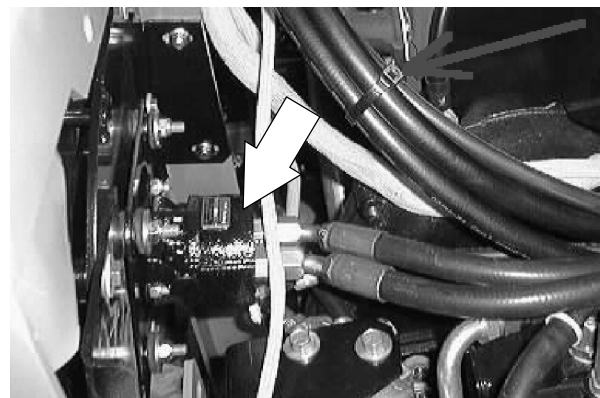



**TO REPLACE SCRUBBING VACUUM FAN MOTOR**

**FOR SAFETY: Before Leaving Or Servicing Machine; Stop On Level Surface, Set Parking Brake, Turn Off Machine And Remove Key.**

1. Remove the scrubbing vacuum fan assembly from the machine. See TO REMOVE SCRUBBING VACUUM FAN ASSEMBLY instructions in the SCRUBBING section.

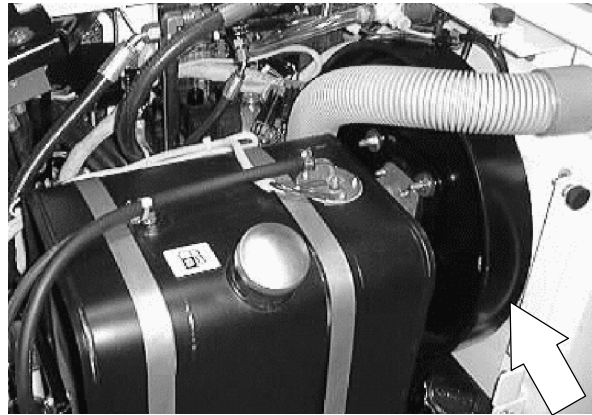

2. Remove the one hex screw, washer, and nyloc nut holding the inlet plate to the vacuum fan assembly. lift the inlet plate off the backing plate.

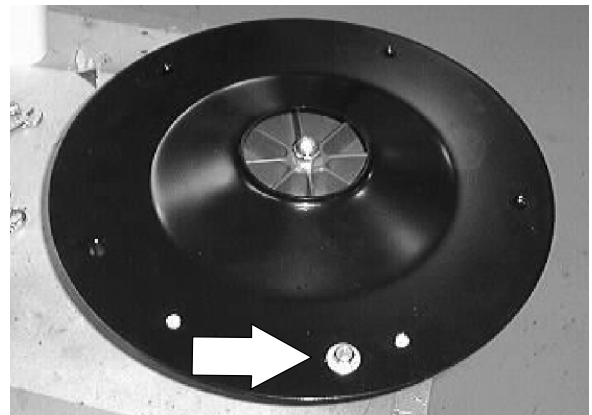

3. Remove the flex lock nut from the center of the fan impeller. Pull the fan impeller straight up and off the vacuum fan hydraulic motor. Make sure to retain the square key.

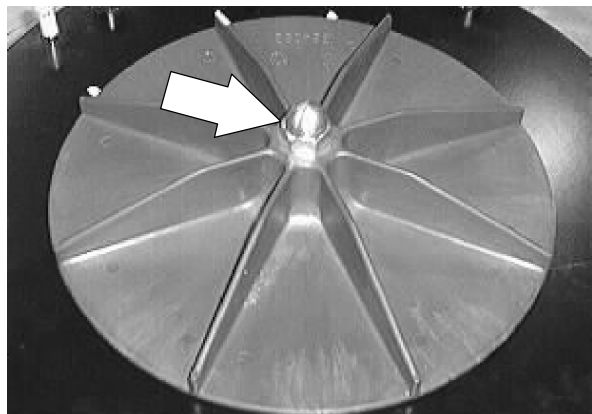

## HYDRAULICS

4. Remove the four flat screws, washers, and nyloc nuts holding the fan motor mount plate to the vacuum plate.

*NOTE: Note the orientation of the hydraulic motor fittings to the pins on the vacuum plate.*

5. Remove the motor and mount plate assembly.

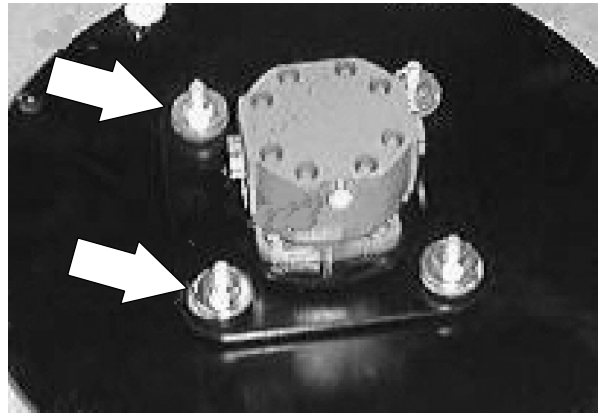

6. Remove the four flat screws, washers, and nyloc nuts holding the fan motor to the mount plate. Remove the motor.

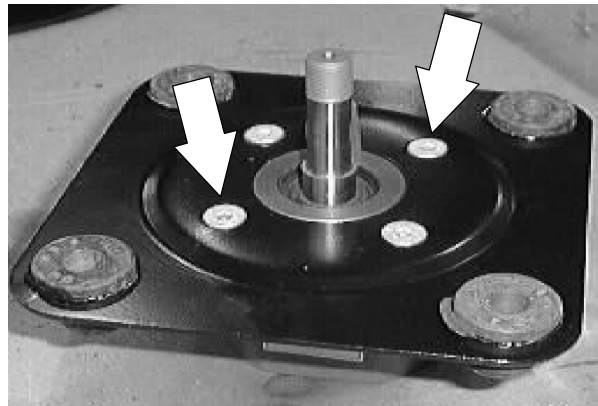

7. Remove the hydraulic fittings from the old motor and install in the new motor in the same orientation.

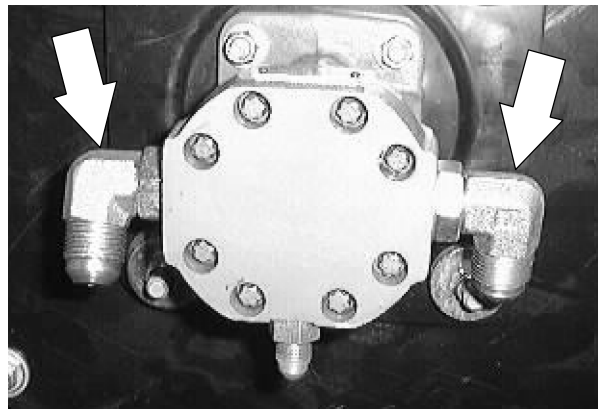

8. Install the new fan motor onto the mount plate. Install the four flat screws, washers, and nyloc nuts. Tighten to 11 - 14 Nm (7 - 10 ft lbs). The motor can be installed on the mount plate in any orientation.

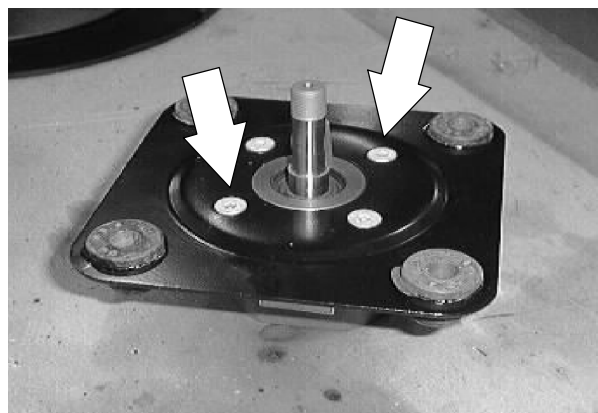

9. Install the fan and mount plate assembly onto the vacuum plate.

**NOTE:** Note the orientation of the hydraulic motor fittings to the pins on the vacuum plate.

10. Install the four flat screws, washers, and nyloc nuts. Tighten to 18 - 24 Nm (15 - 20 ft lbs).

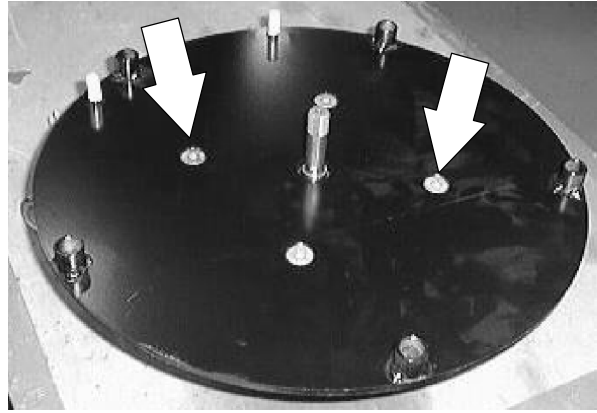

11. Install the impeller onto the vacuum fan hydraulic motor shaft. Make sure the square key is in place on the motor shaft. Install the flex lock nut. Use a small amount of blue loctite 242 on the threads. Tighten to 37 - 48 Nm (26 - 34 ft lbs).

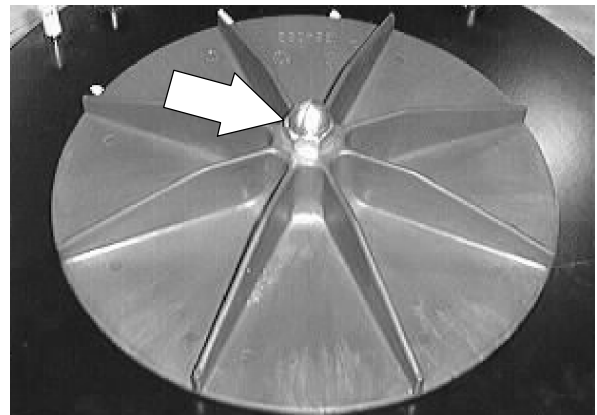

12. Install the inlet plate onto the vacuum plate assembly. The inlet plate can only be installed one way. Install the one hex screw, washer, and nyloc nut. Tighten to 18 - 24 Nm (15 - 20 ft lbs).

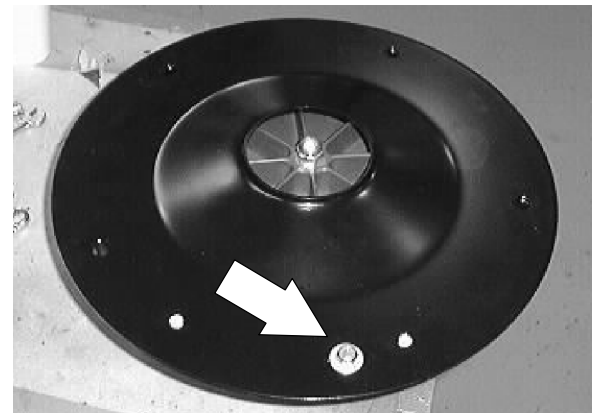

13. Reinstall the scrubbing vacuum fan assembly into the machine. See TO INSTALL SCRUBBING VACUUM FAN ASSEMBLY instructions in the SCRUBBING section.

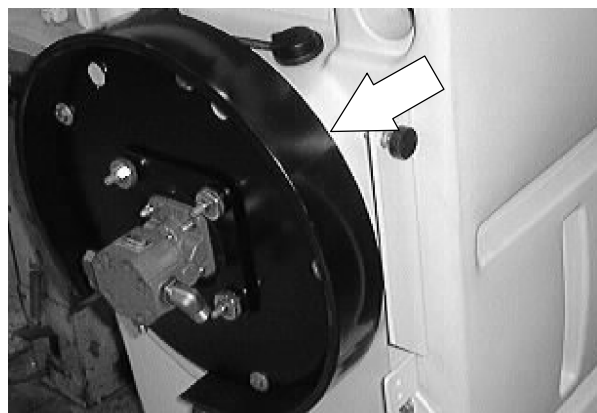

## HYDRAULICS

### TO REPLACE REAR DRIVE MOTOR

**FOR SAFETY: Before Leaving Or Servicing Machine; Stop On Level Surface, Set Parking Brake, Turn Off Machine And Remove Key.**

1. Engage parking brake, block front tires.

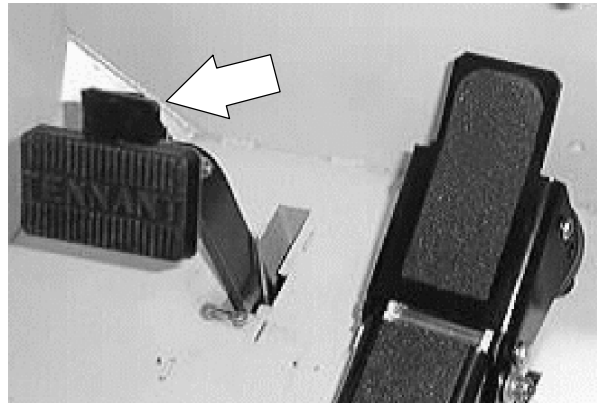

2. Jack up rear of machine. Use jack stands to support machine.

**FOR SAFETY: Block machine tires before jacking machine up. Jack machine up at designated locations only. Block machine up with jack stands.**



3. Remove the rear tire and wheel assembly from the drive motor hub.

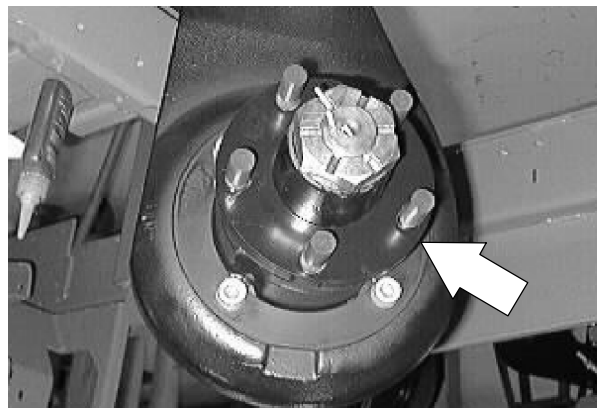

4. Remove the cotter pin and slotted nut from drive motor shaft and hub.

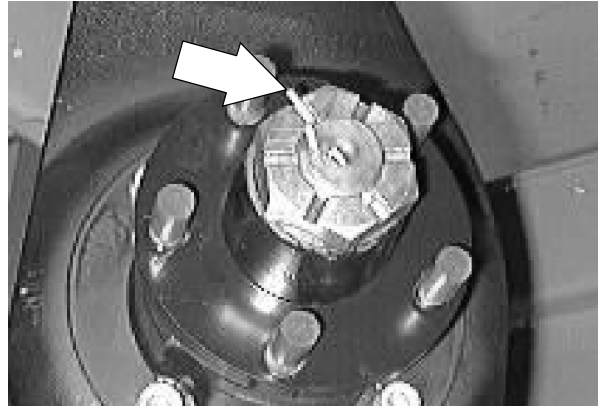

5. Use a puller to remove the drive hub from the tapered motor shaft.

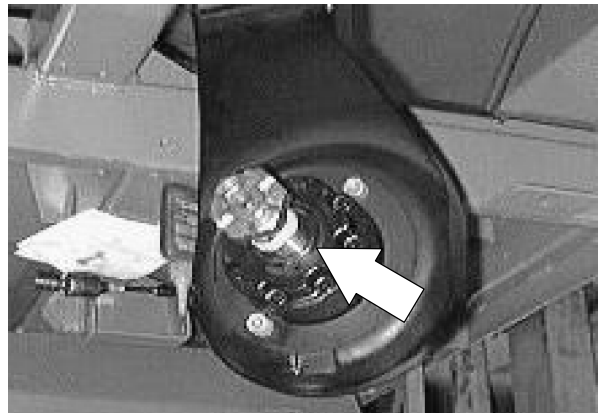

6. Reinstall the hose clamp to the wheel housing. Tighten the hex screws to 18.5 - 24Nm (15 - 20 ft lb).

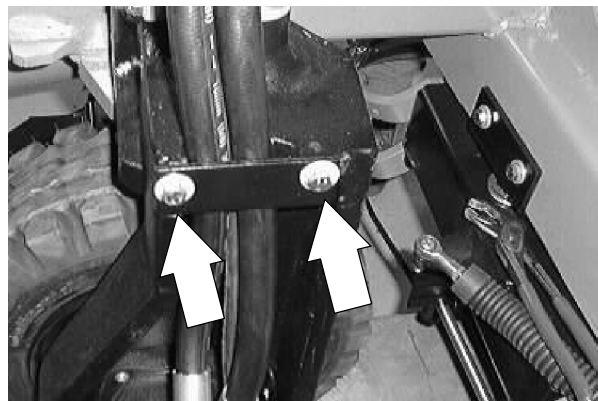

7. Mark, disconnect, and plug the hydraulic hoses leading to the the drive motor.

*NOTE: Observe hydraulic cleanliness requirements when opening hydraulic lines.*

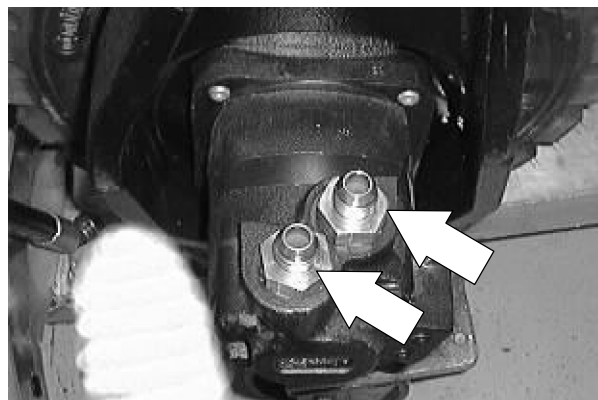

8. Remove the rear drive motor mounting bolts.

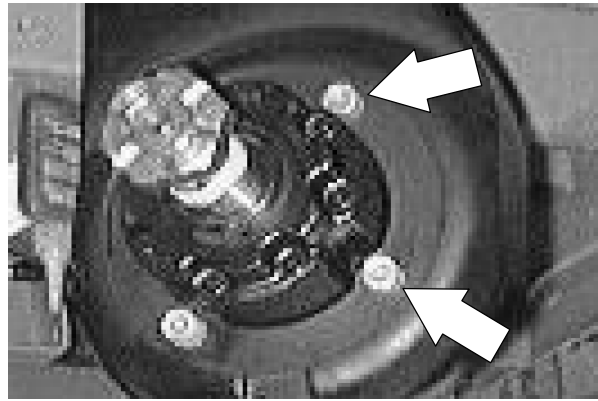

9. Slide the rear drive motor out of the wheel housing.

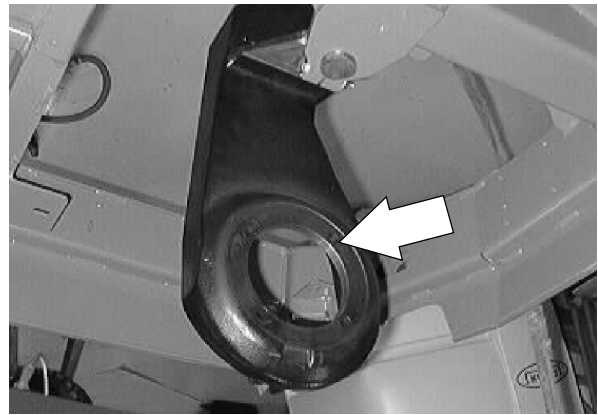

10. Slide the drive motor in the wheel housing.  
*Note the motor orientation.*

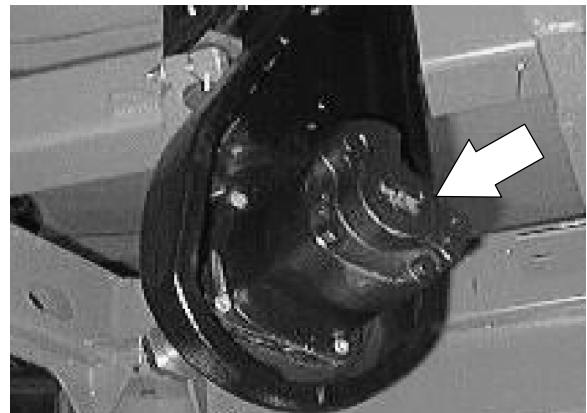

11. Thread the four hex screws through the wheel housing and into the motor. Tighten to 88-115 Nm (65-85 ft lb).

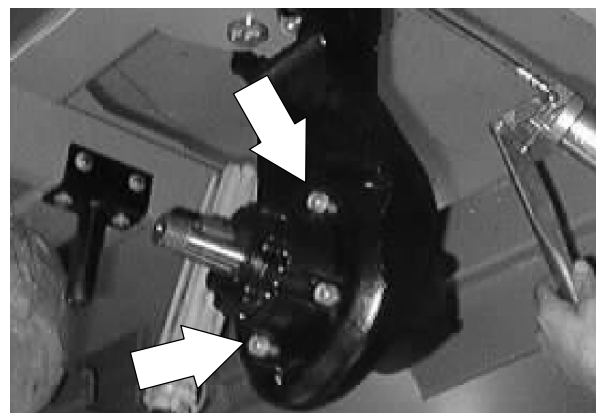

12. Reconnect the hydraulic hoses. See schematic in the HYDRAULICS section.

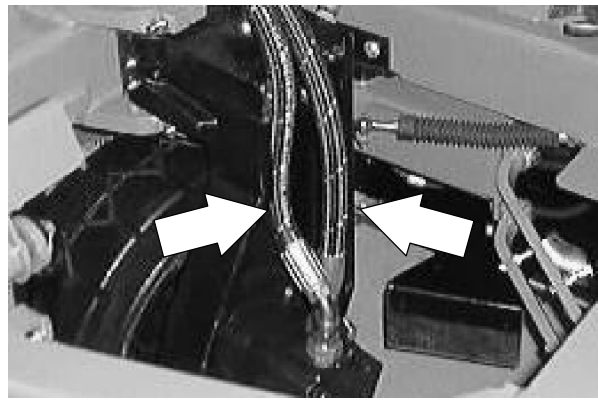

13. Reinstall the hose clamp to the wheel housing. Tighten the hex screws to 18.5 - 24Nm (15 - 20 ft lb).

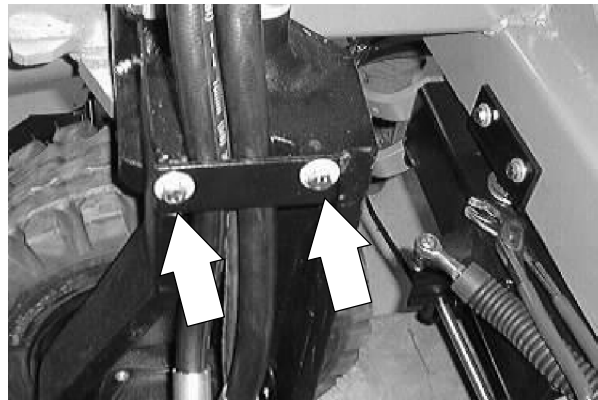

14. Mount the hub to the tapered motor shaft. Tighten the slotted nut to (275 ft lb). Torque to the next slot in nut. DO NOT back nut off to install cotter pin. *Install the cotter pin.*

*NOTE: Make sure the key is installed on the tapered shaft of the drive motor and a small amount of grease is placed on the shaft.*

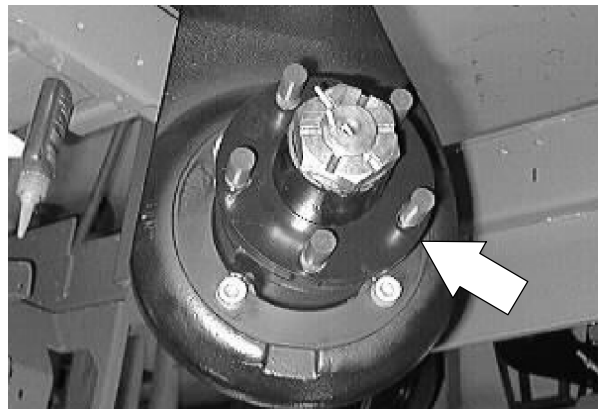

15. Install the rear tire and wheel assembly. Torque the rear wheel nuts to 100 - 120 Nm (85 - 95 ft lb).



## HYDRAULICS

16. Start the engine. Run the propelling in both directions. Check for any leaks.

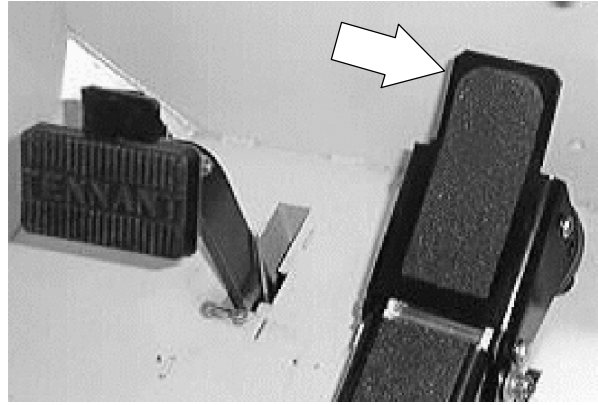

17. Remove the jack stands and lower the machine to the ground.



18. Operate the machine and check for proper operation of the drive motor.





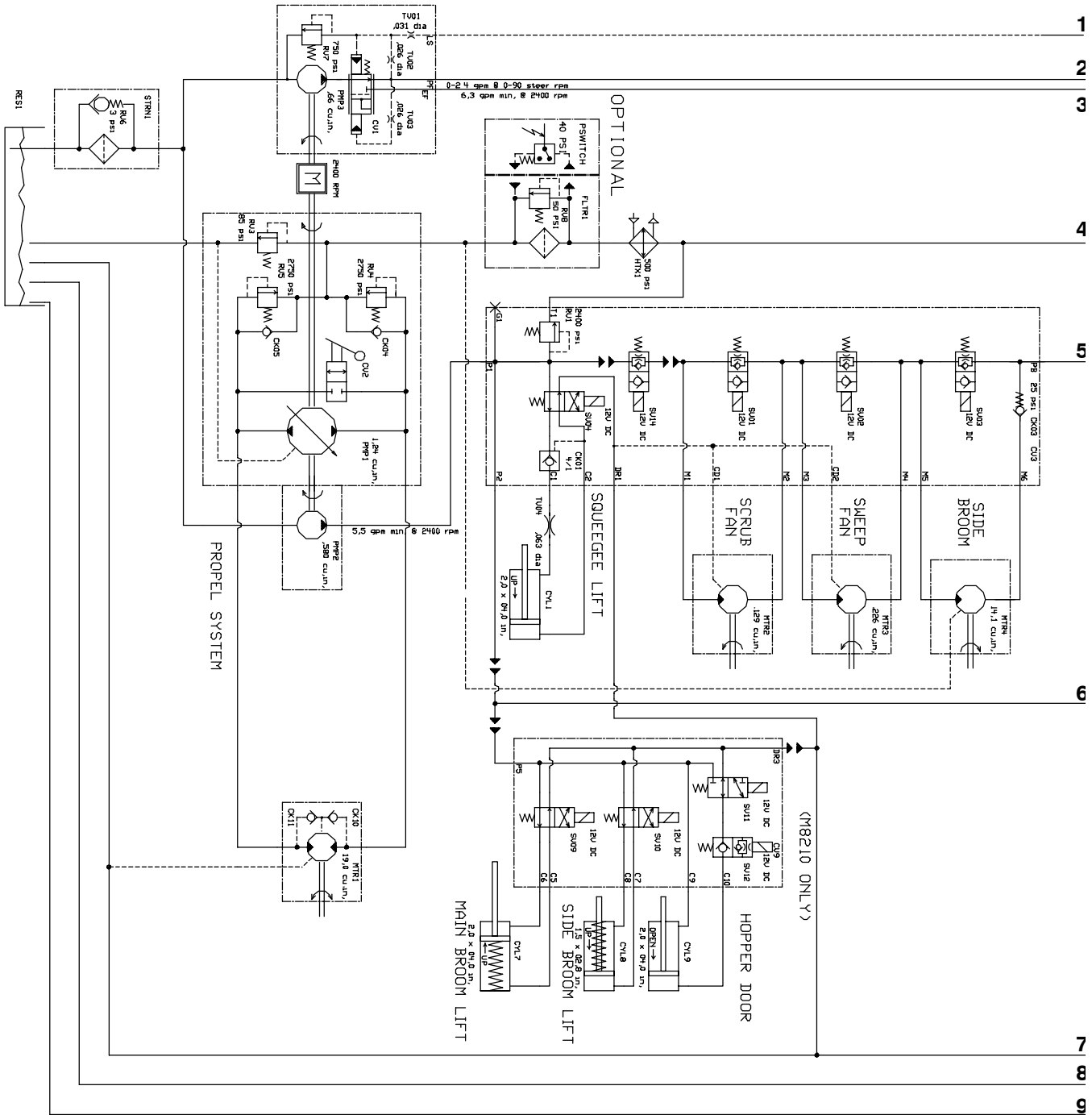

HYDRAULIC SCHEMATIC

351672 - ALL

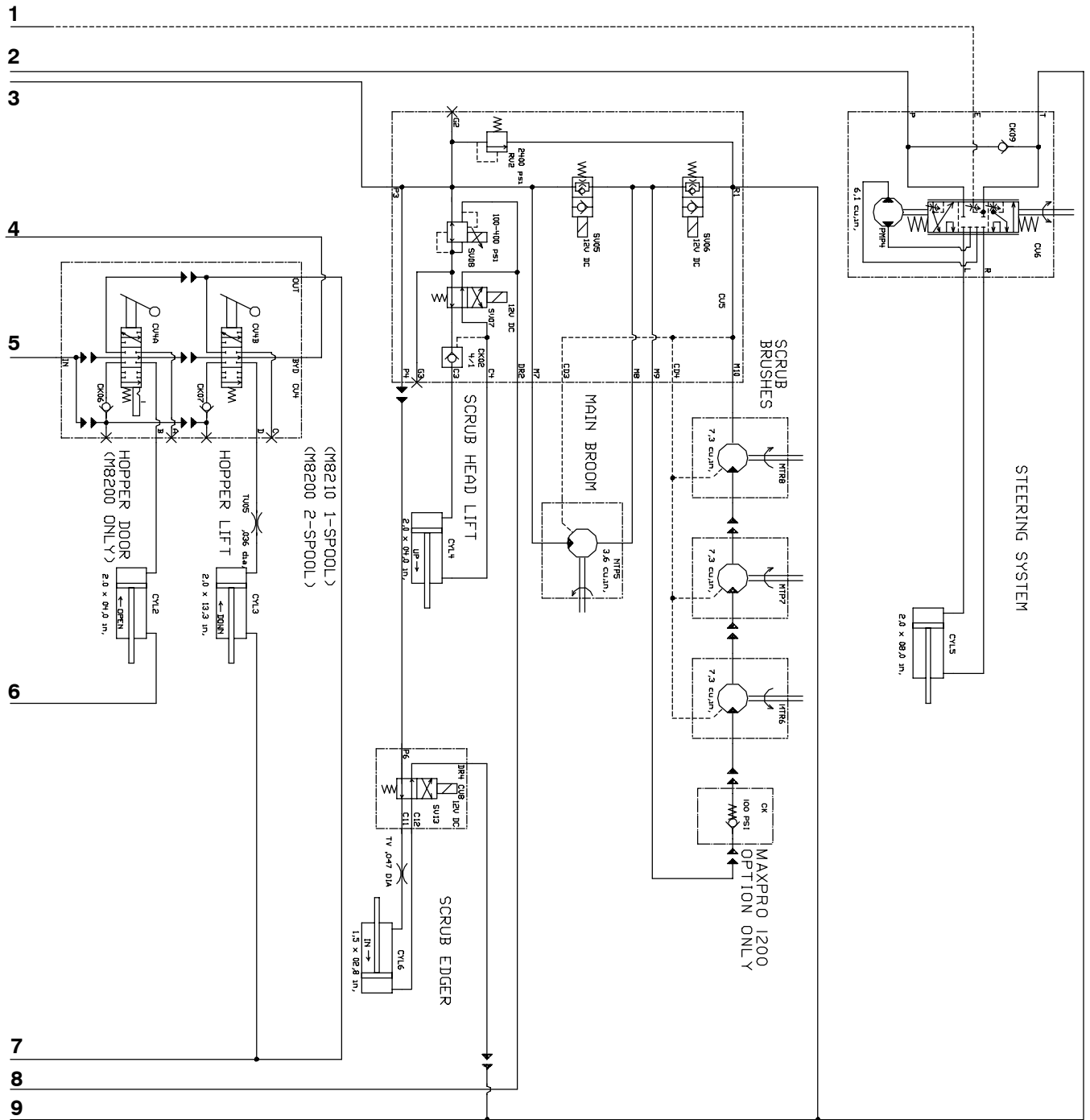

HYDRAULIC SCHEMATIC

351672 - ALL

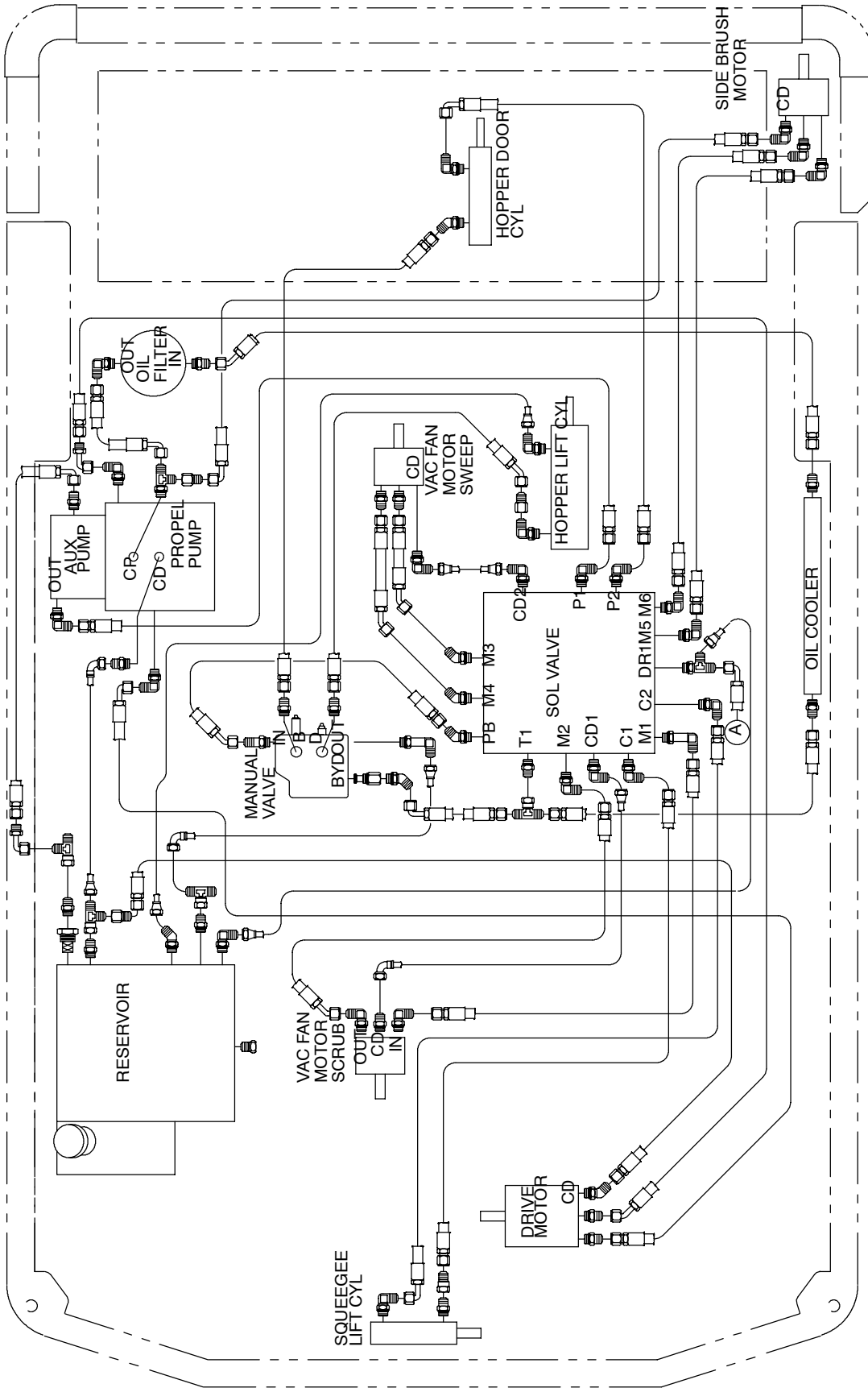

HYDRAULIC HOSE DIAGRAM (8200)

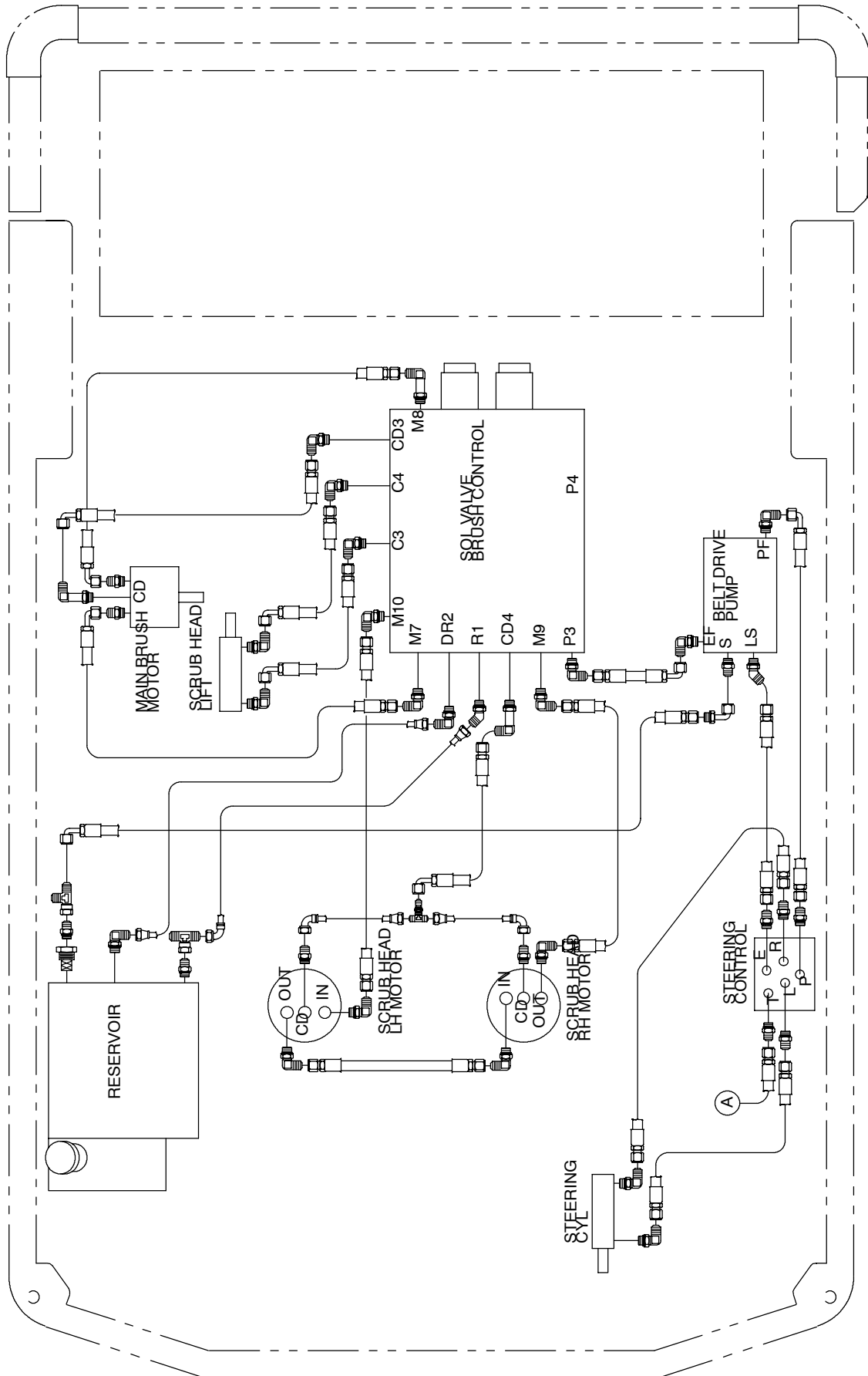

HYDRAULIC HOSE DIAGRAM (8200)

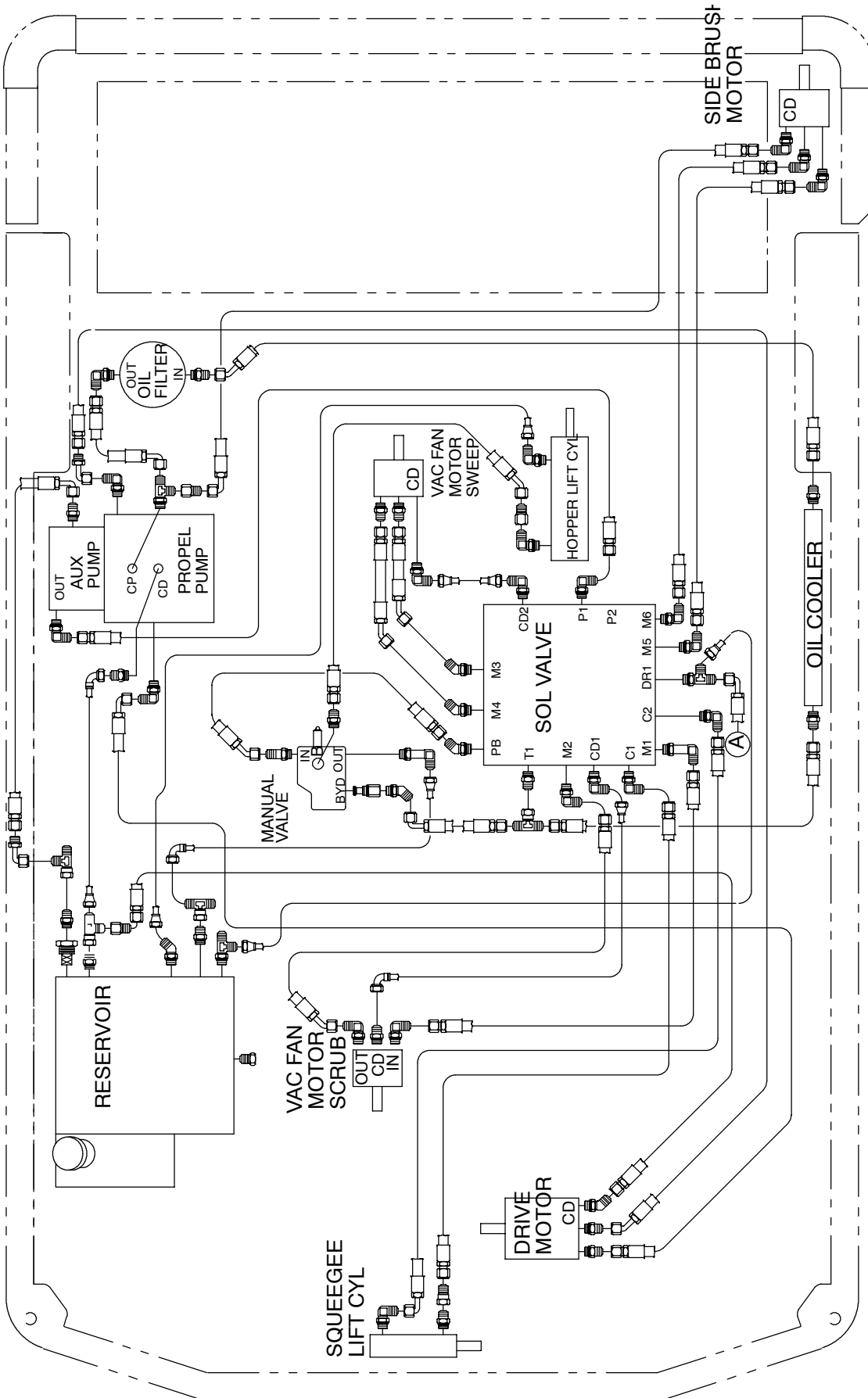

HYDRAULIC HOSE DIAGRAM (8210)

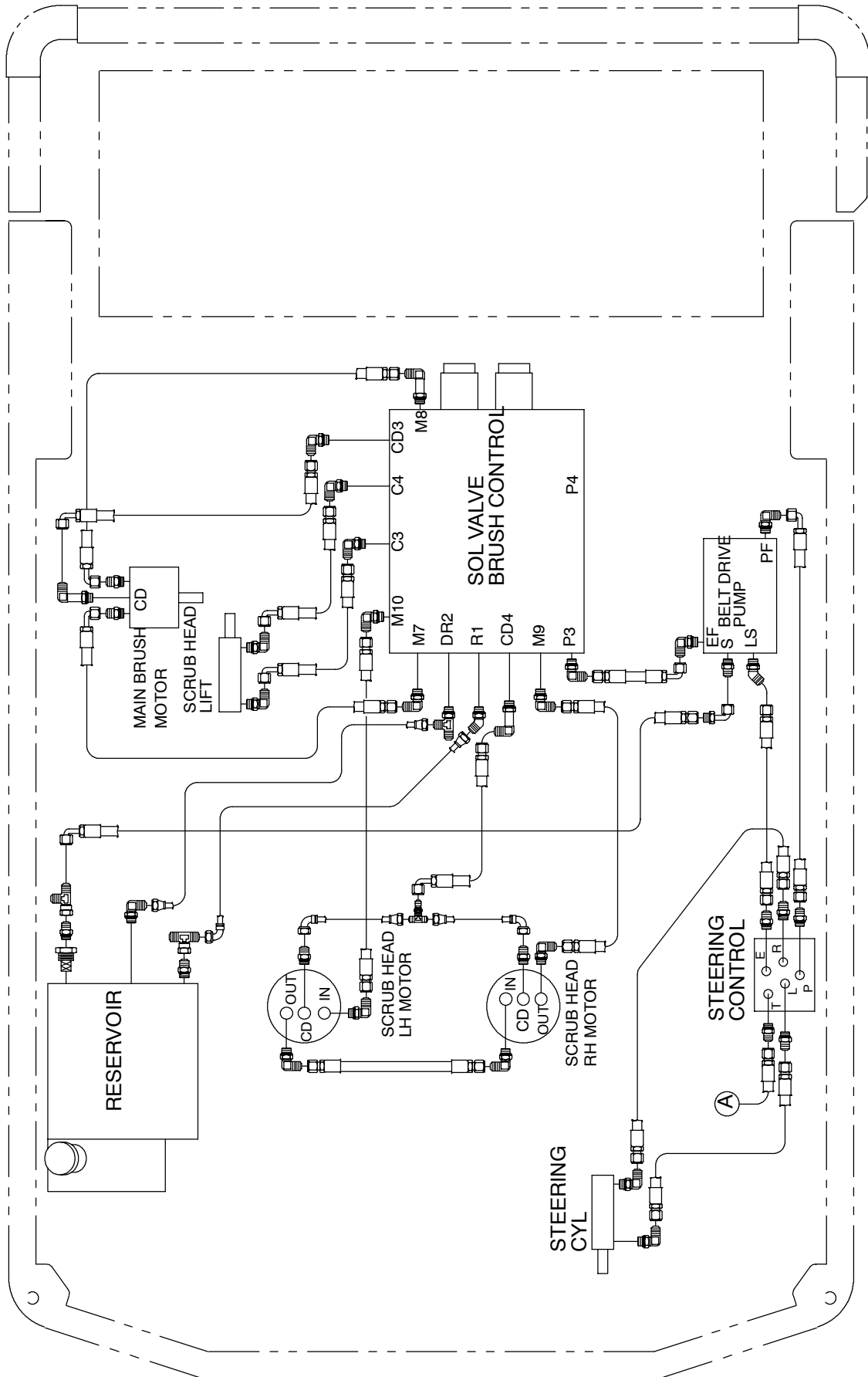

HYDRAULIC HOSE DIAGRAM (8210)

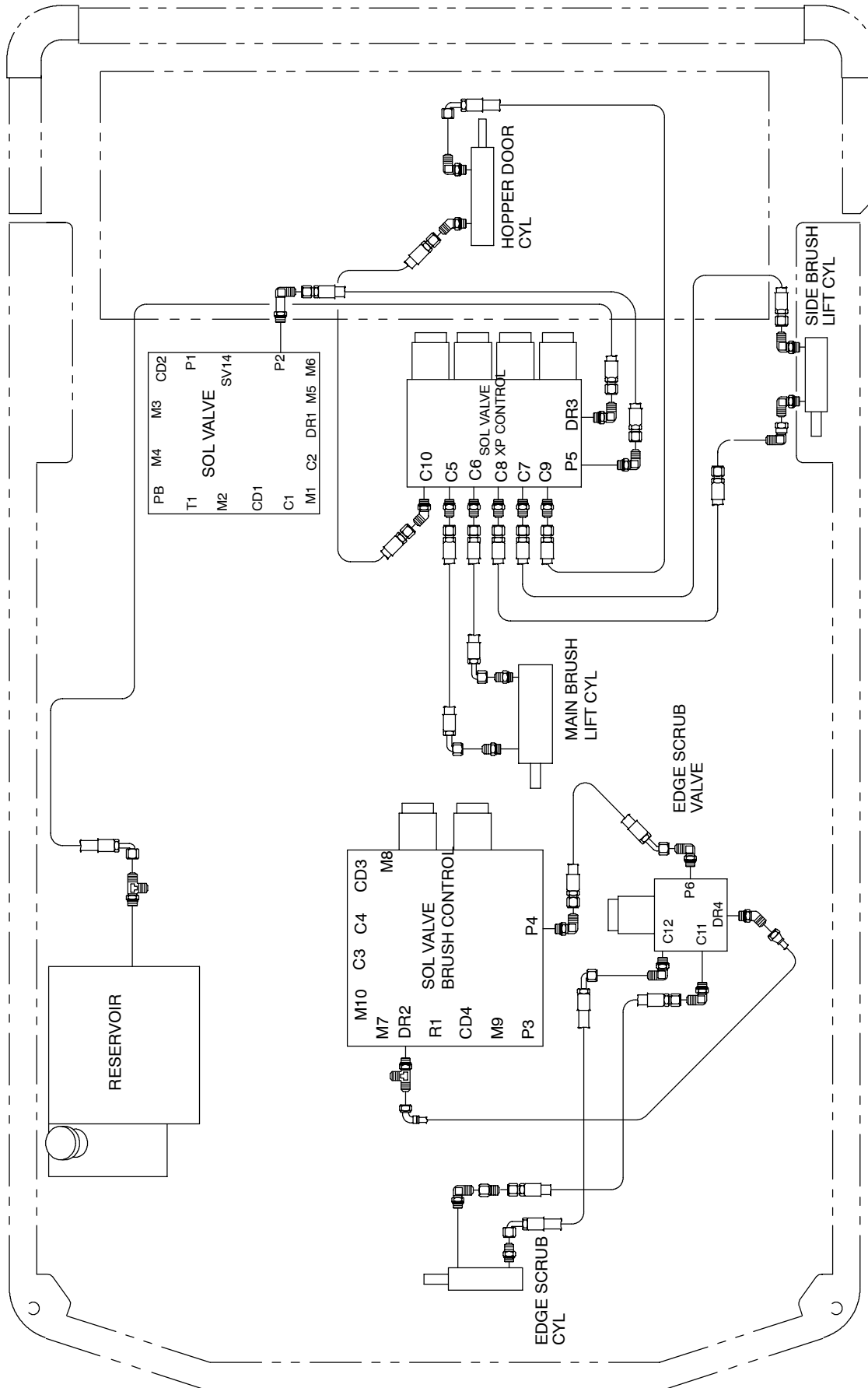

HYDRAULIC HOSE DIAGRAM (8210)



**TROUBLESHOOTING**

The troubleshooting charts that follow are organized so they lead you through the circuits. They include flow charts and instructions for you as to where to insert your test instruments.

**POWER STEERING IS NOT NORMAL**

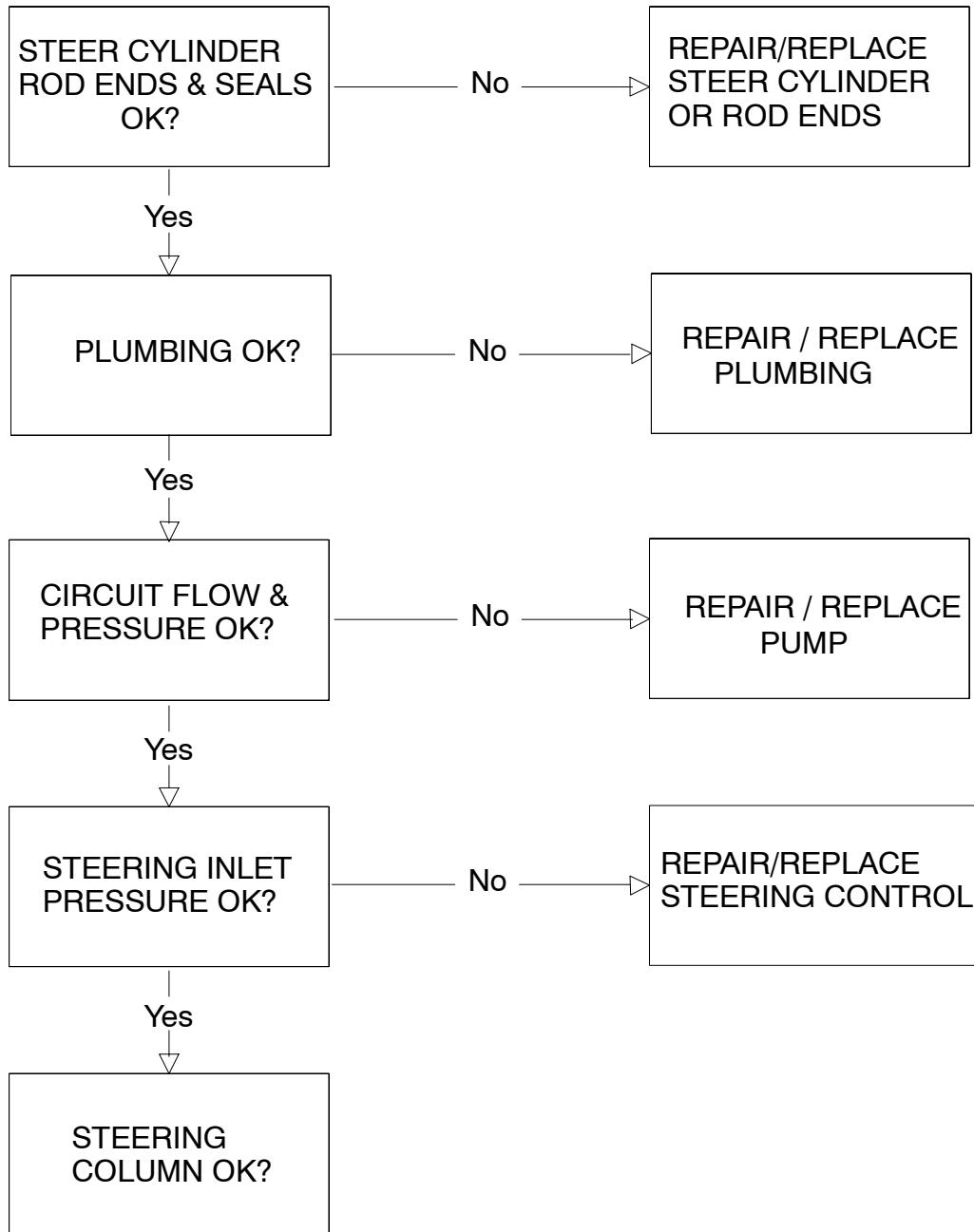

SCRUB HEAD WILL NOT RAISE

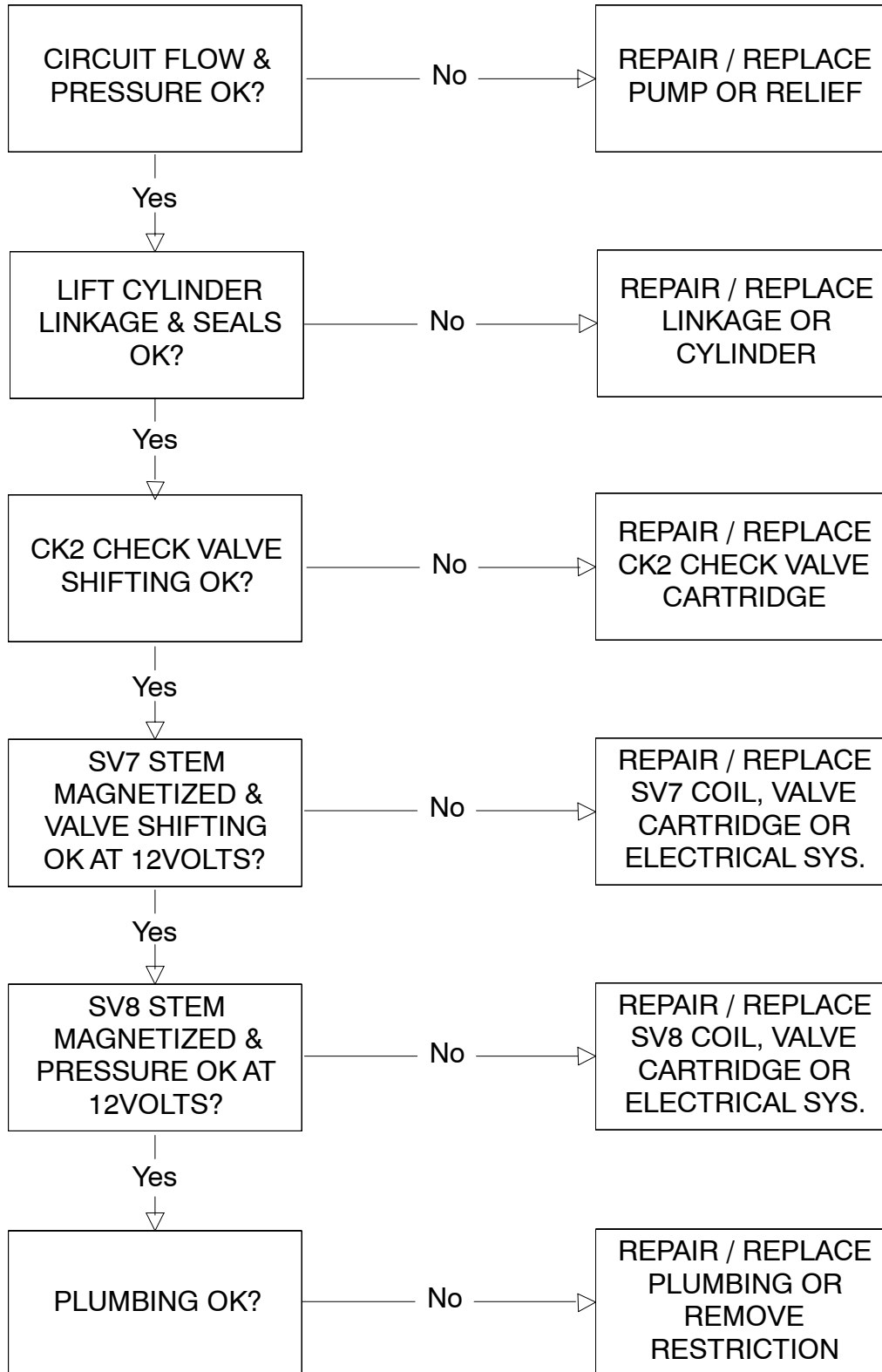

**SCRUB HEAD WILL NOT LOWER**

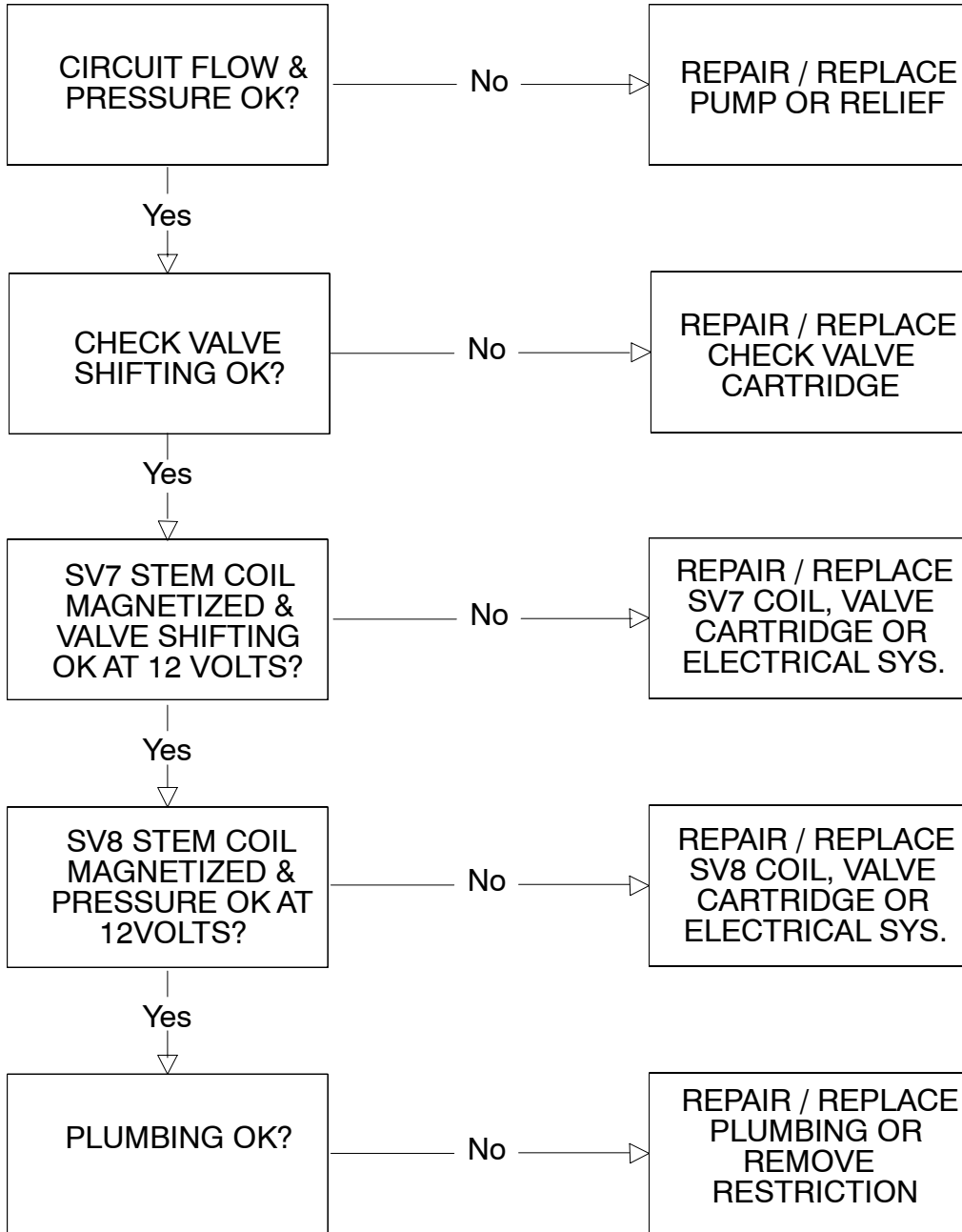

**SCRUB HEAD WILL NOT STAY UP**

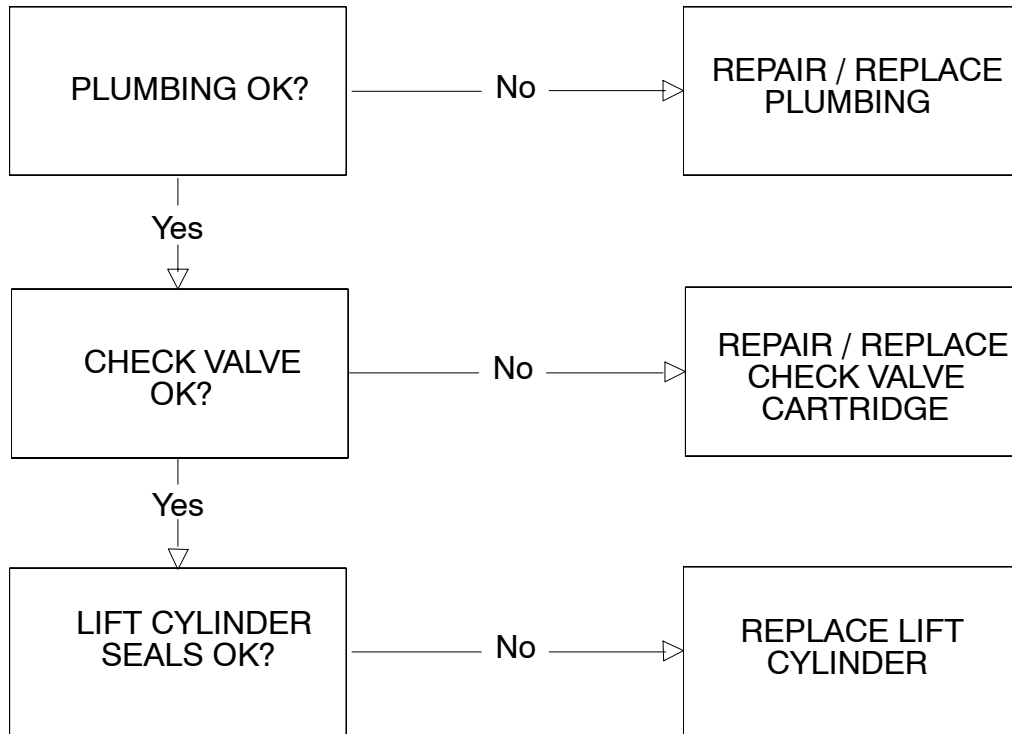

**MAIN BROOM WILL NOT TURN ON**

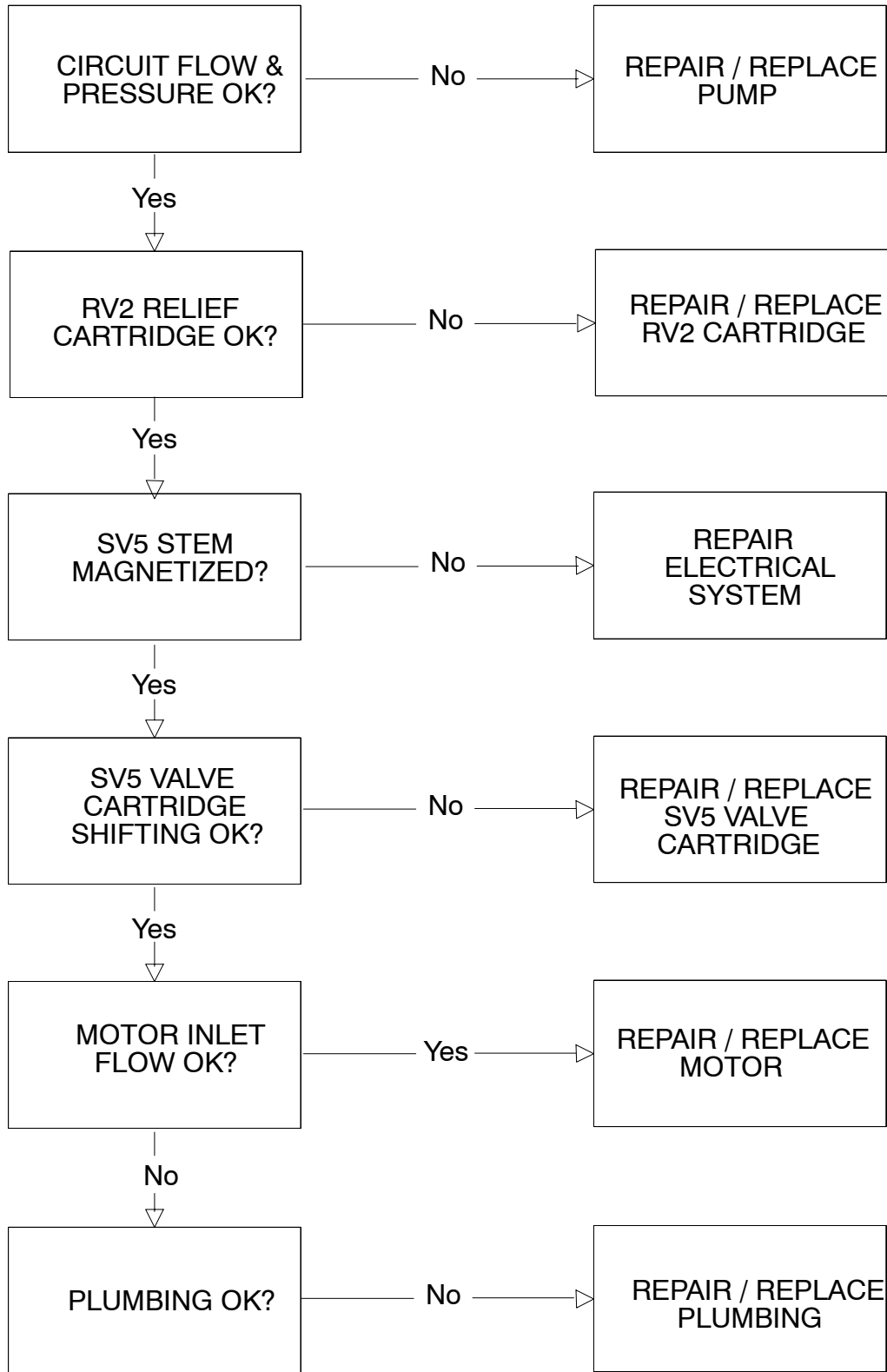

**MAIN BROOM WILL NOT TURN OFF**

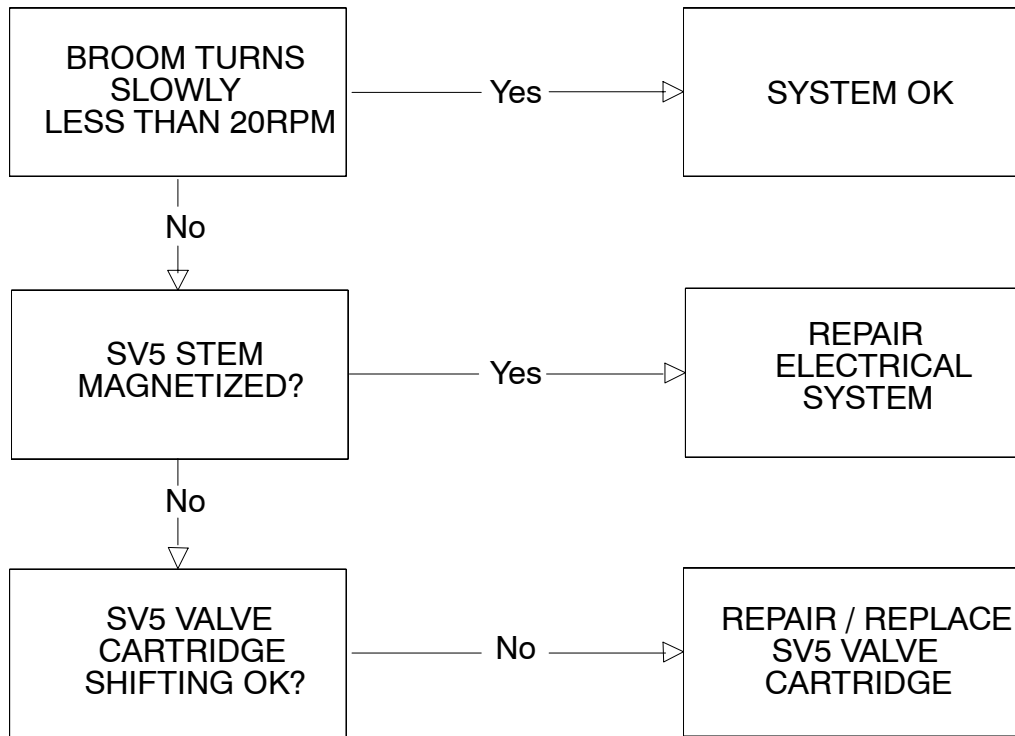

**SCRUB BRUSHES WILL NOT  
TURN ON**

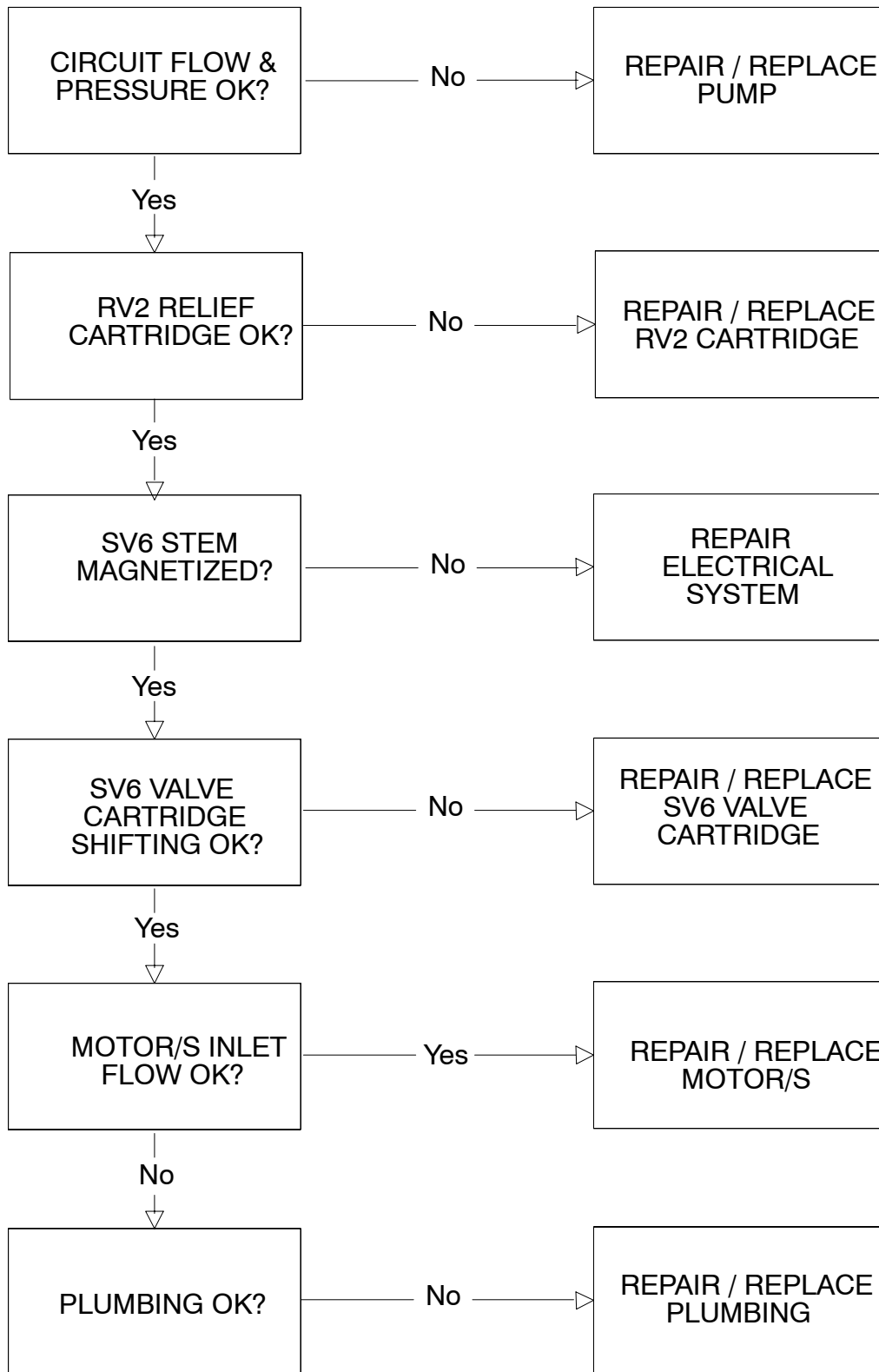



**SCRUB BRUSHES WILL NOT TURN OFF**

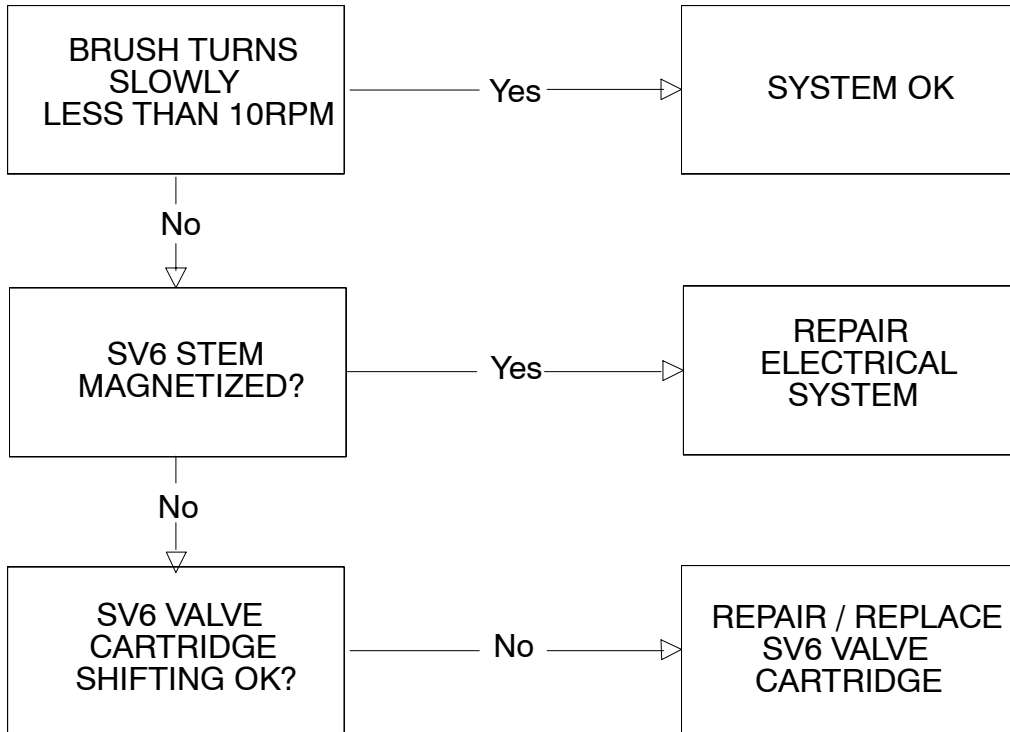

**SQUEEGEE WILL NOT RAISE**

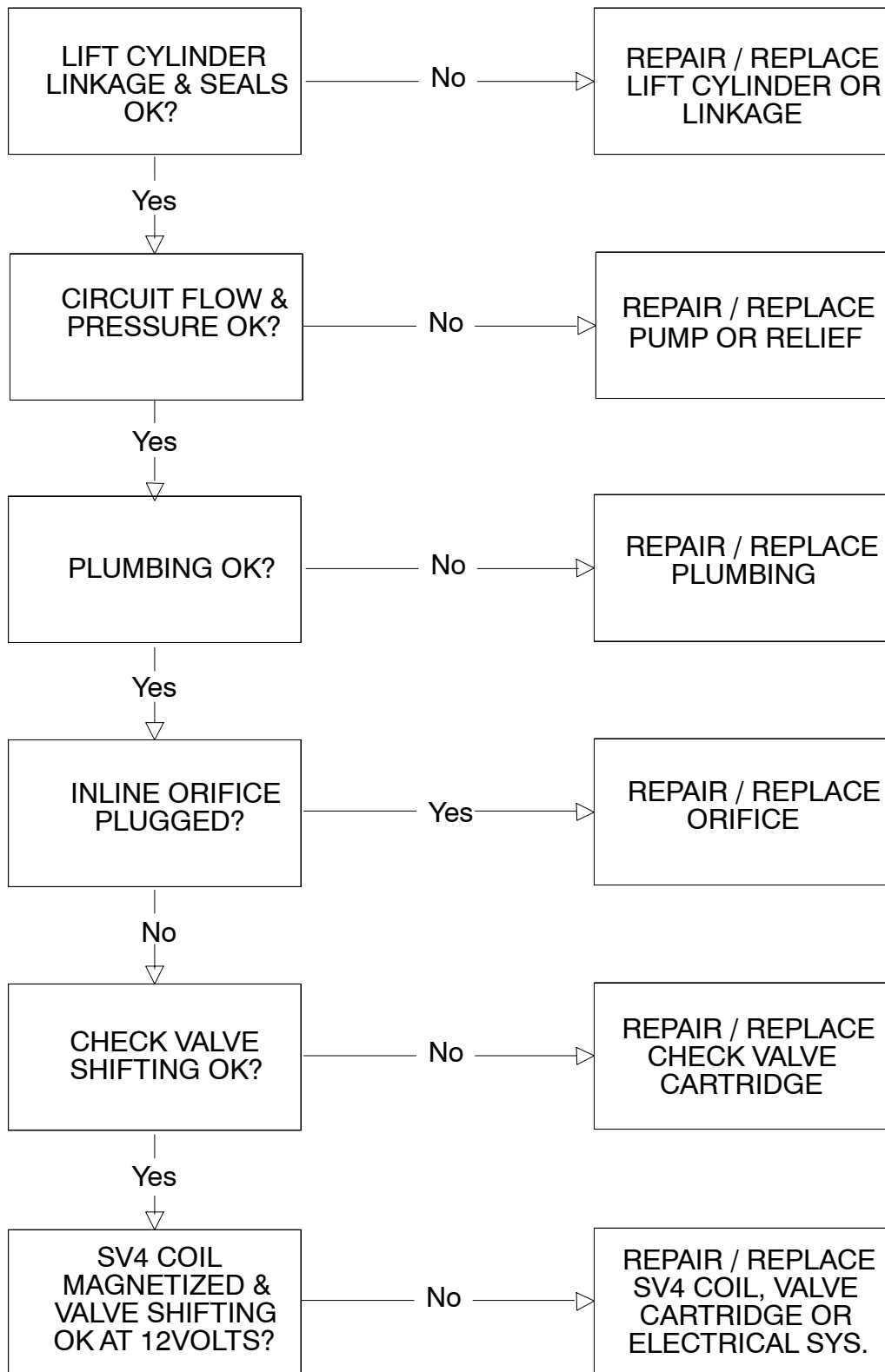

**SQUEEGEE WILL NOT LOWER**

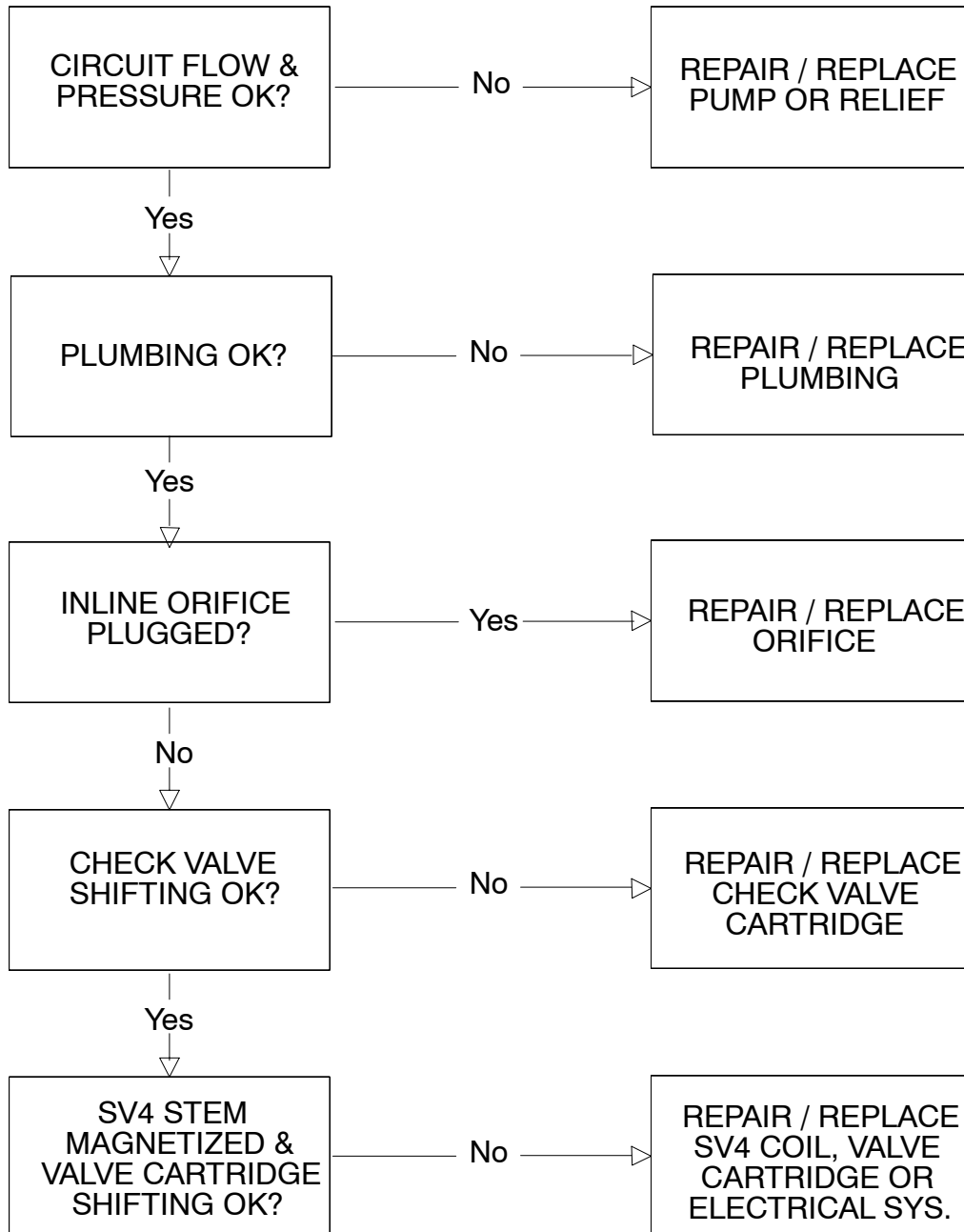

**SQUEEGEE WILL NOT STAY UP**

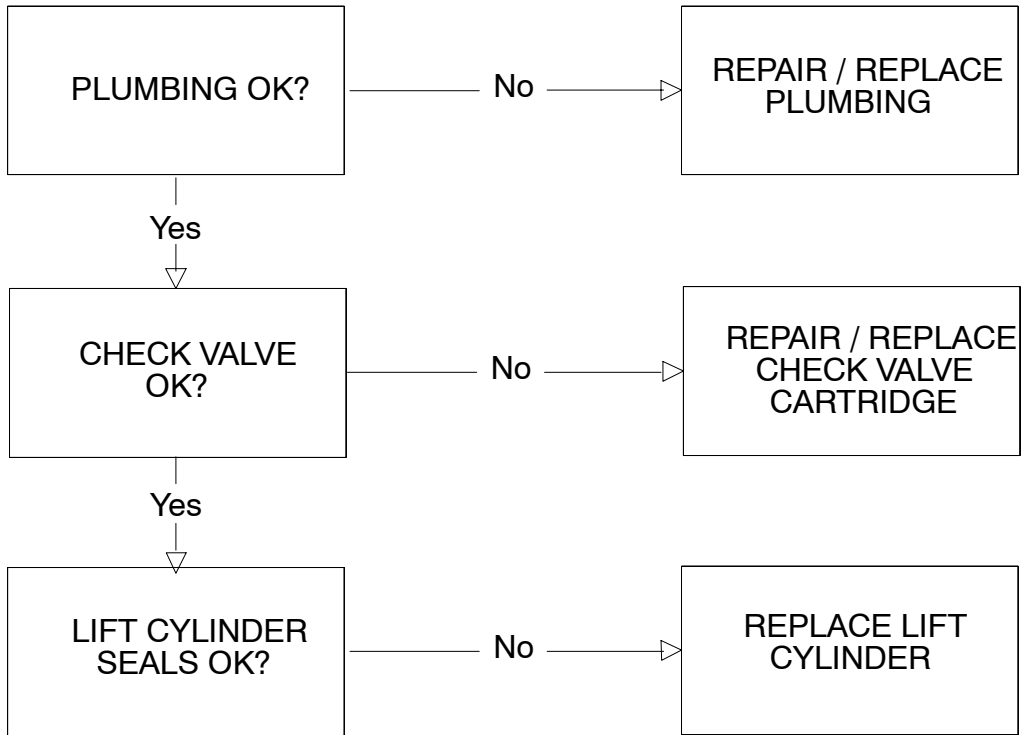

SCRUB FAN WILL NOT TURN ON

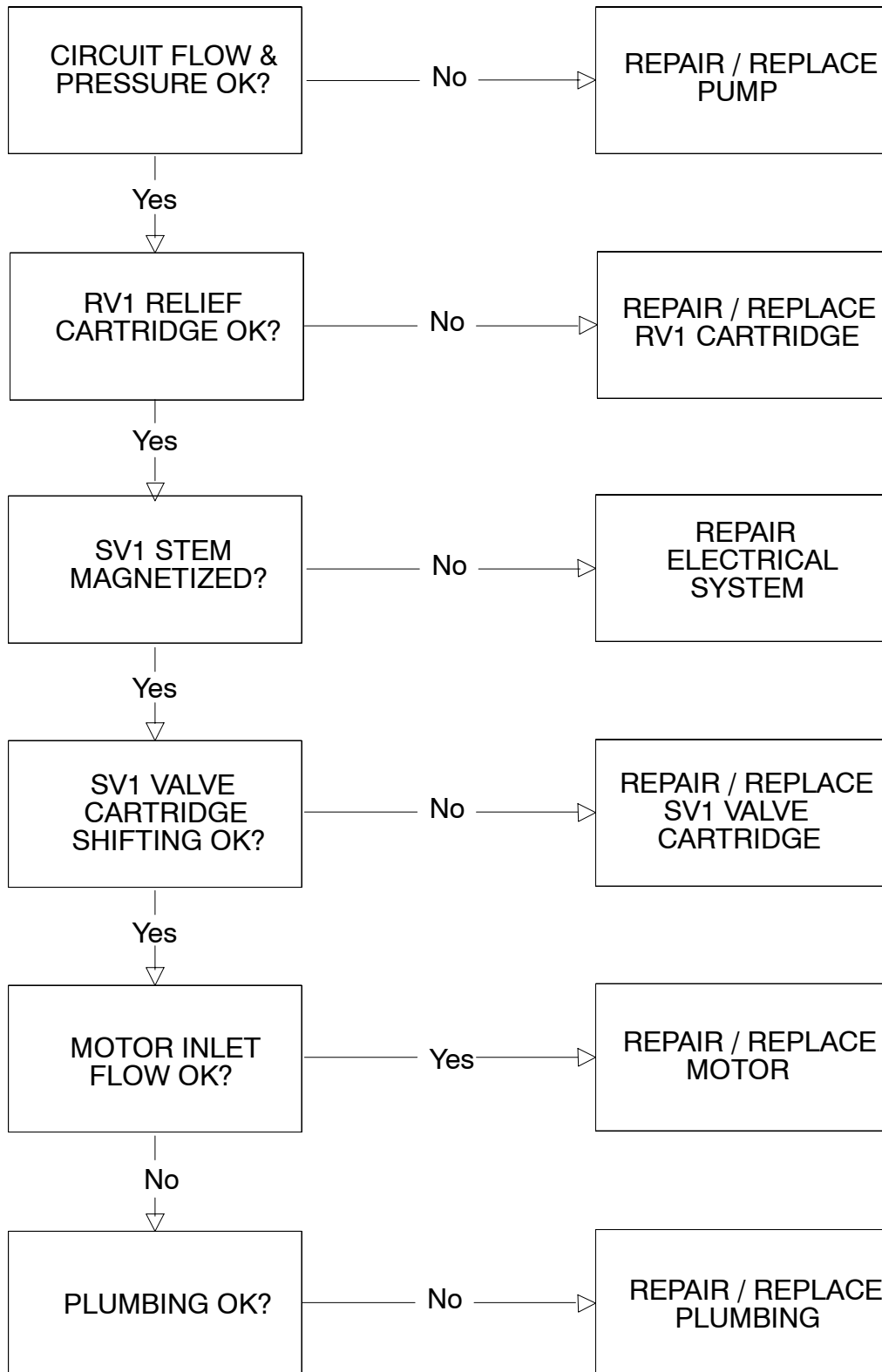

**SCRUB FAN WILL NOT TURN OFF**

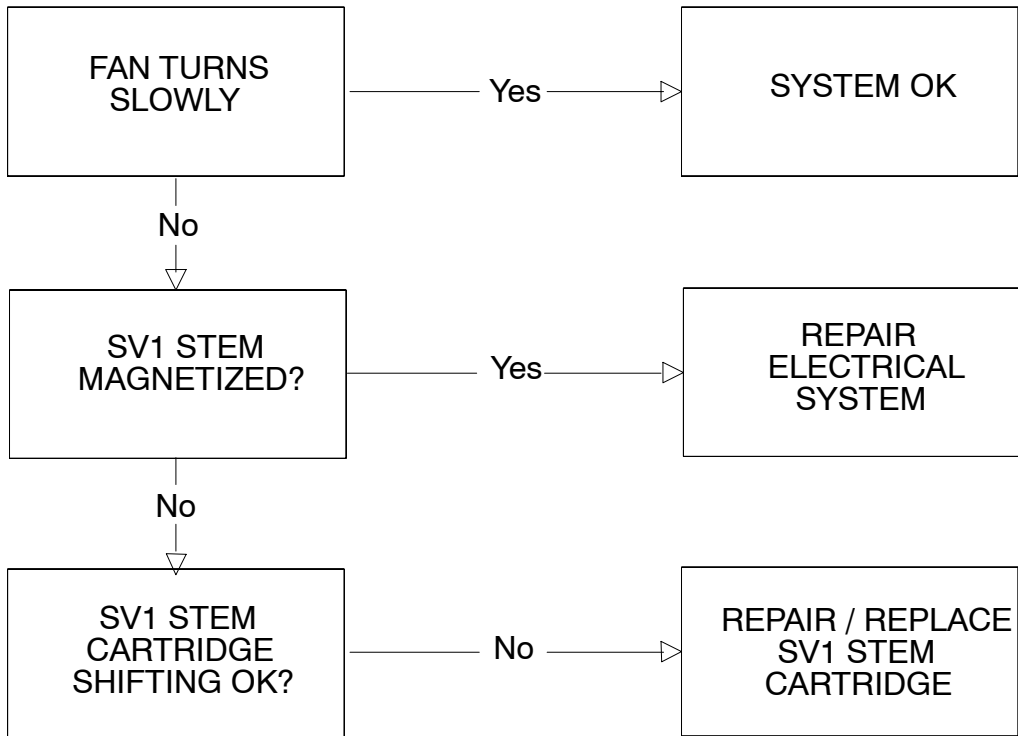

**SWEEP FAN WILL NOT TURN ON**

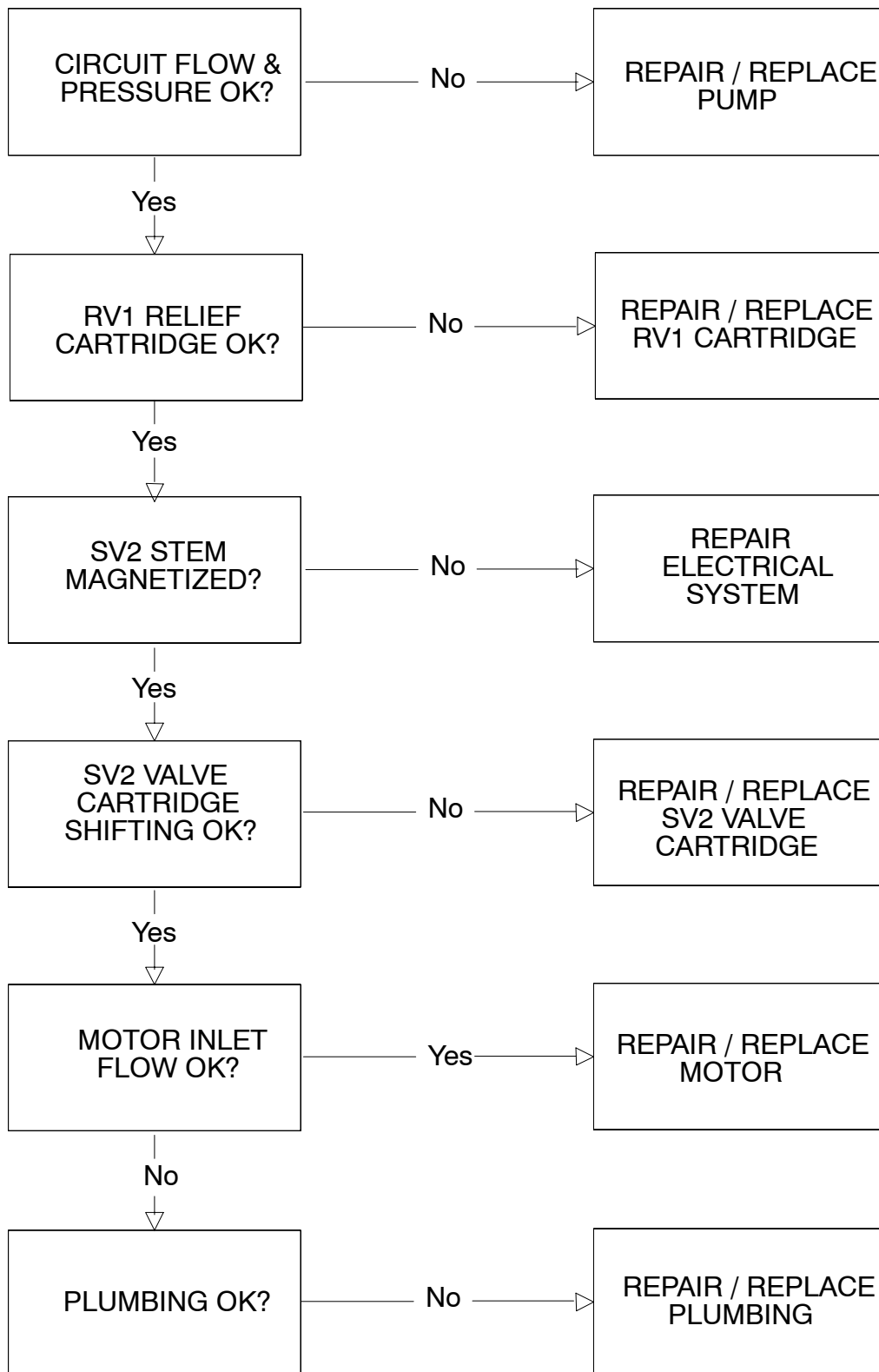

**SWEEP FAN WILL NOT TURN OFF**

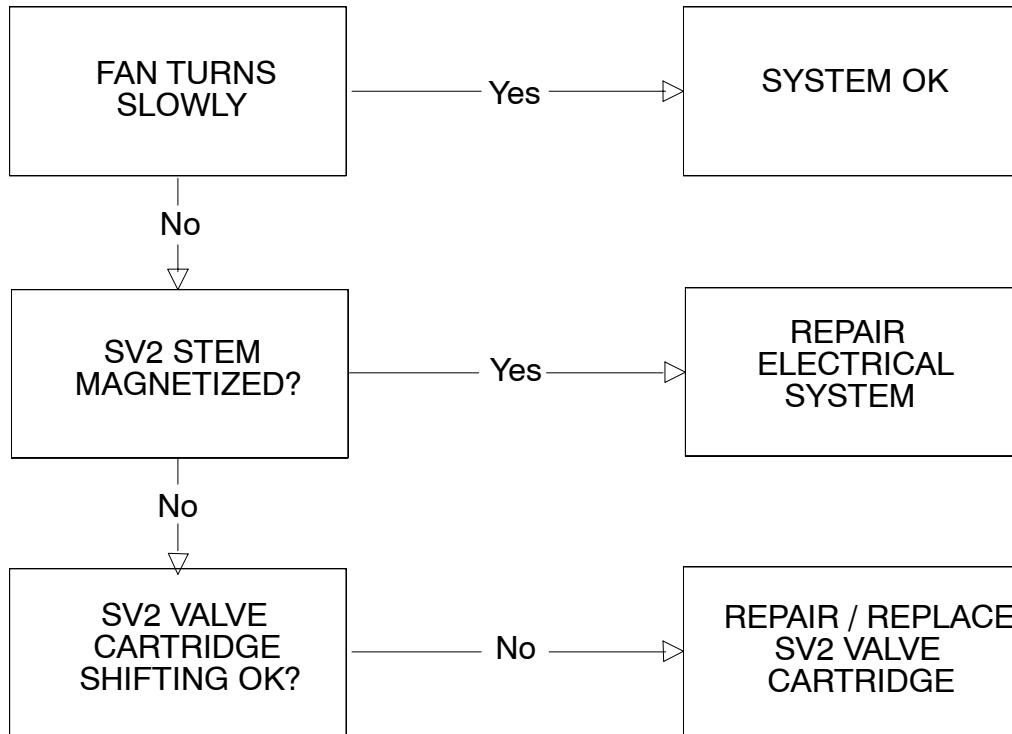



**SIDE BRUSH WILL NOT TURN ON**

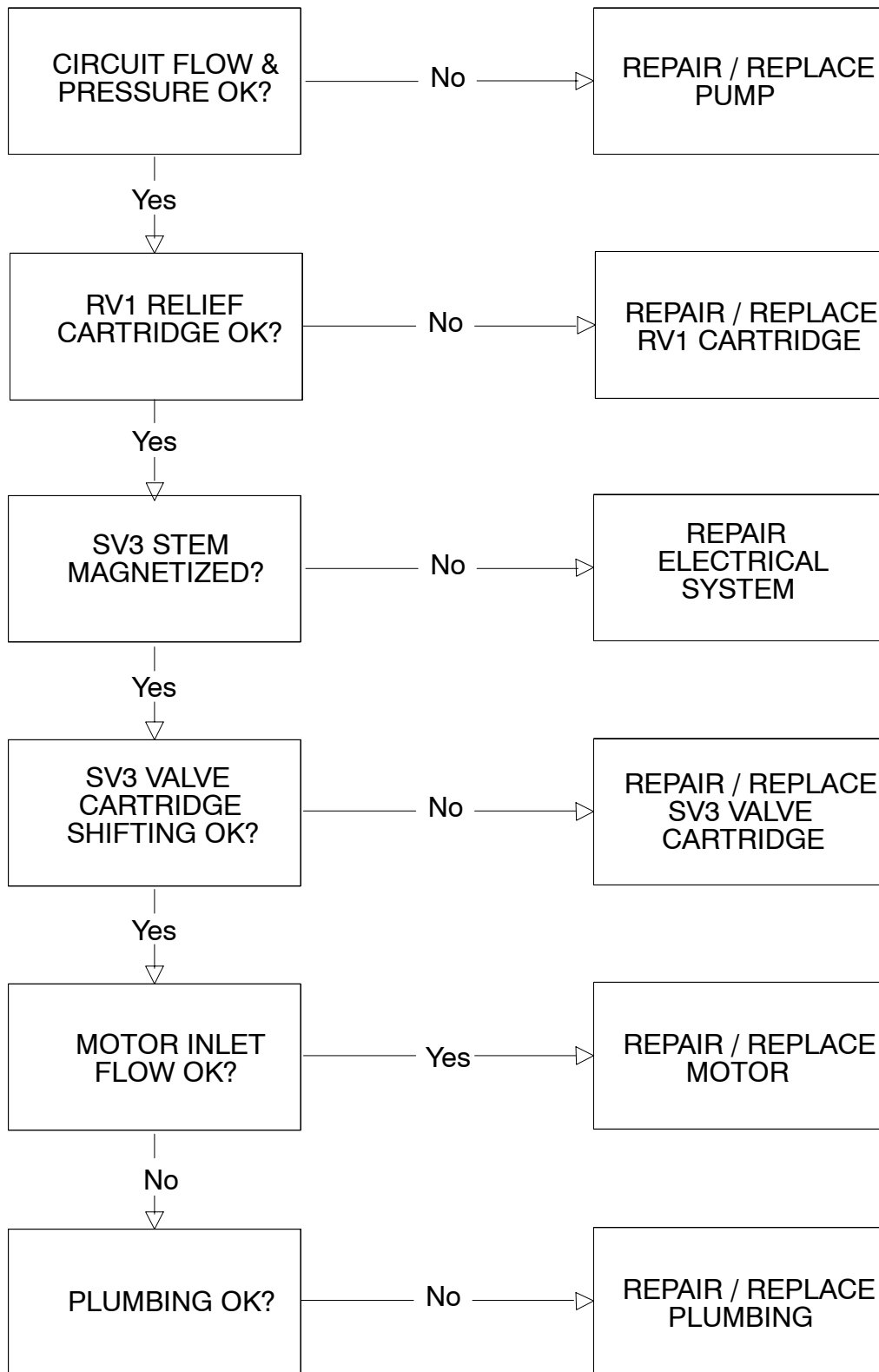

**SIDE BRUSH WILL NOT TURN OFF**

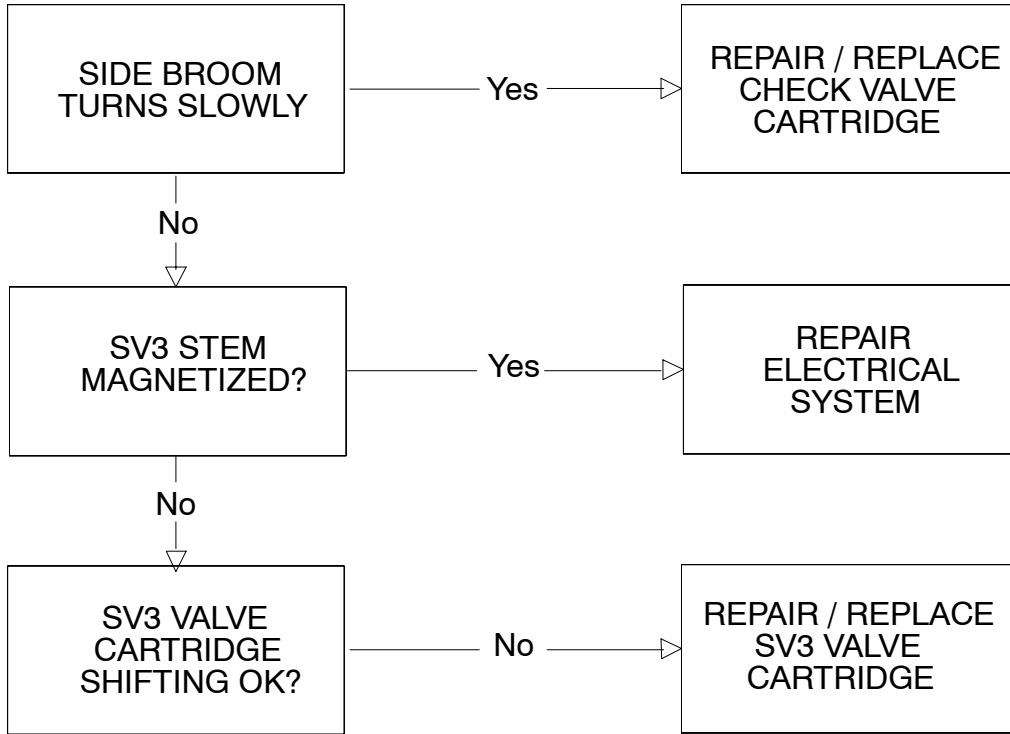

**HOPPER DOOR WILL NOT CLOSE**

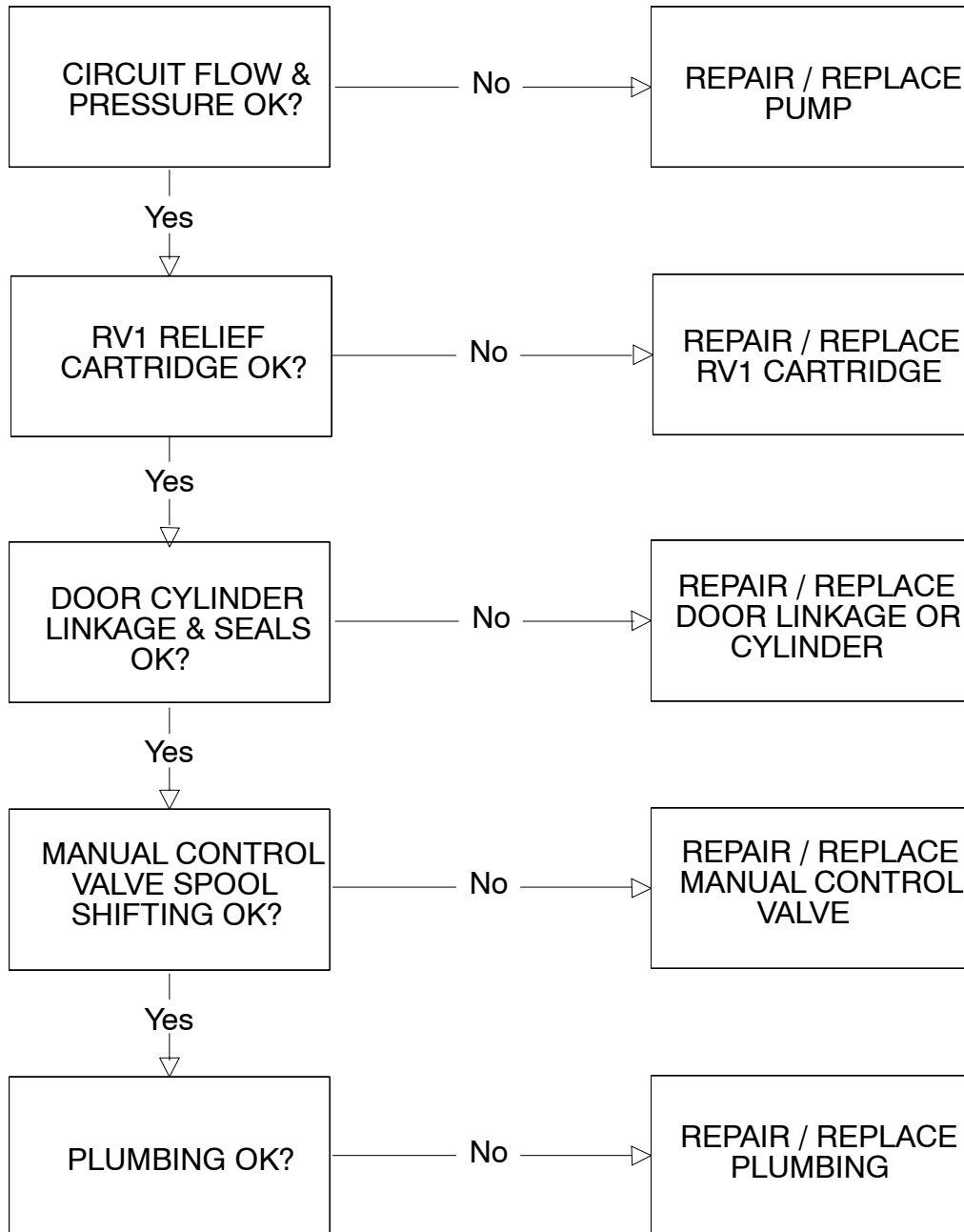

**HOPPER DOOR WILL NOT STAY CLOSED**

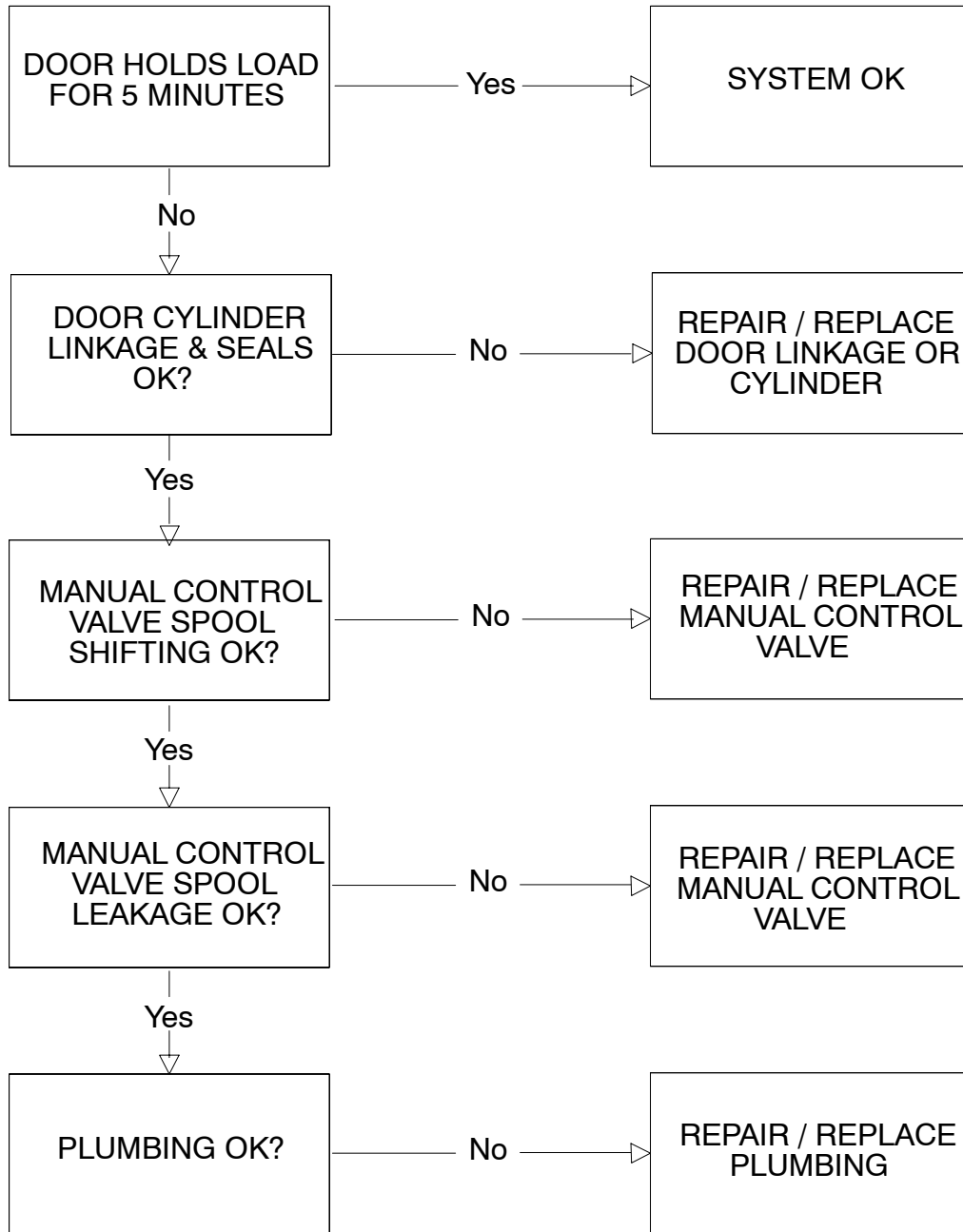

**HOPPER WILL NOT RAISE**

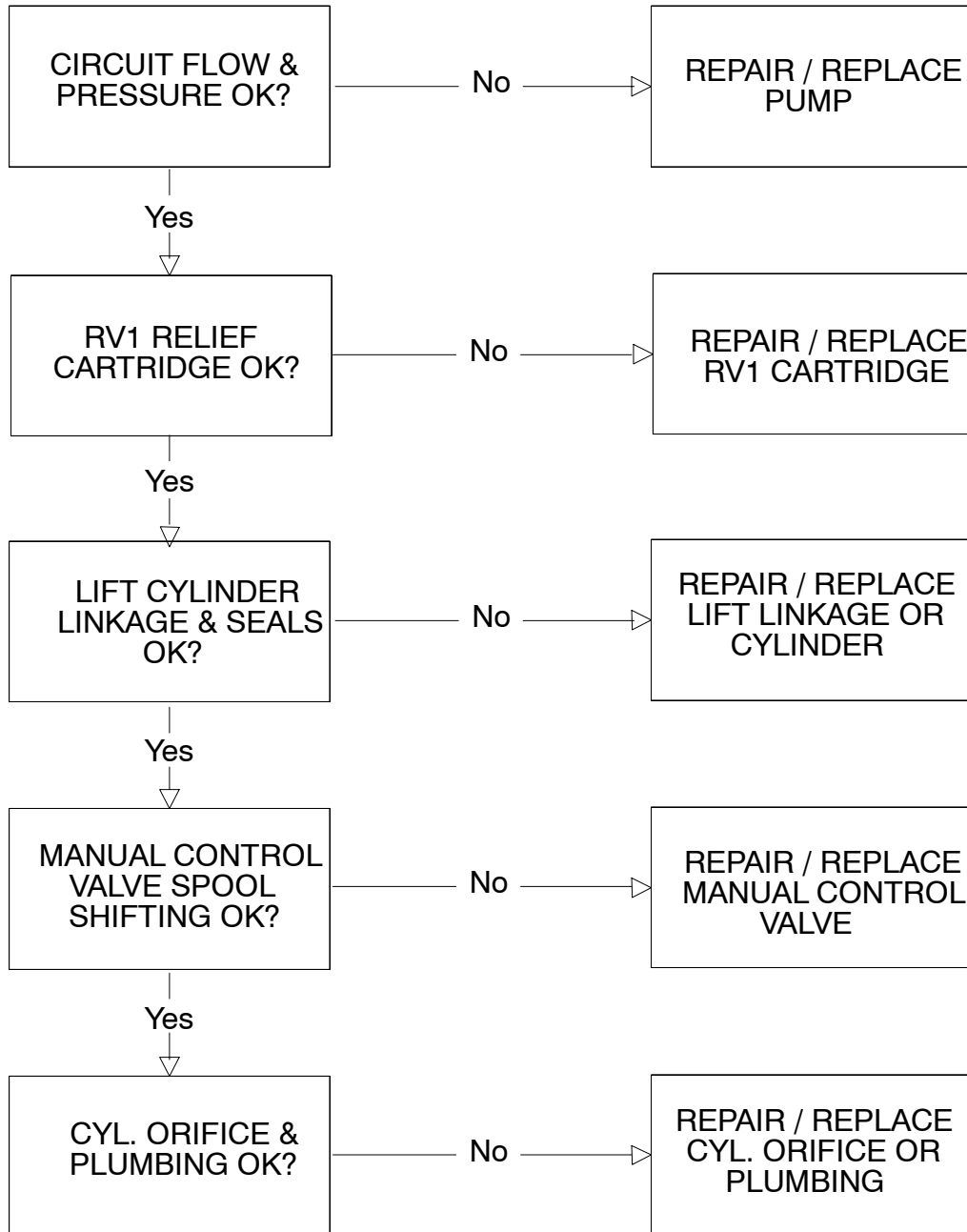

**HOPPER WILL NOT HOLD UP POSITION**

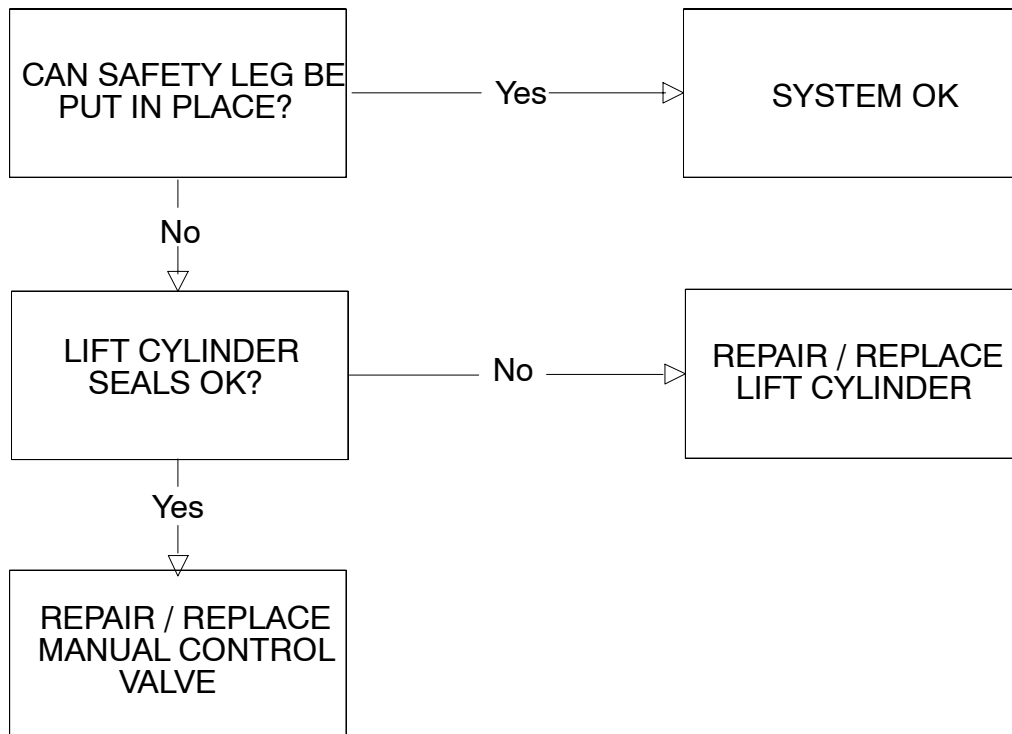

HOPPER WILL NOT LOWER

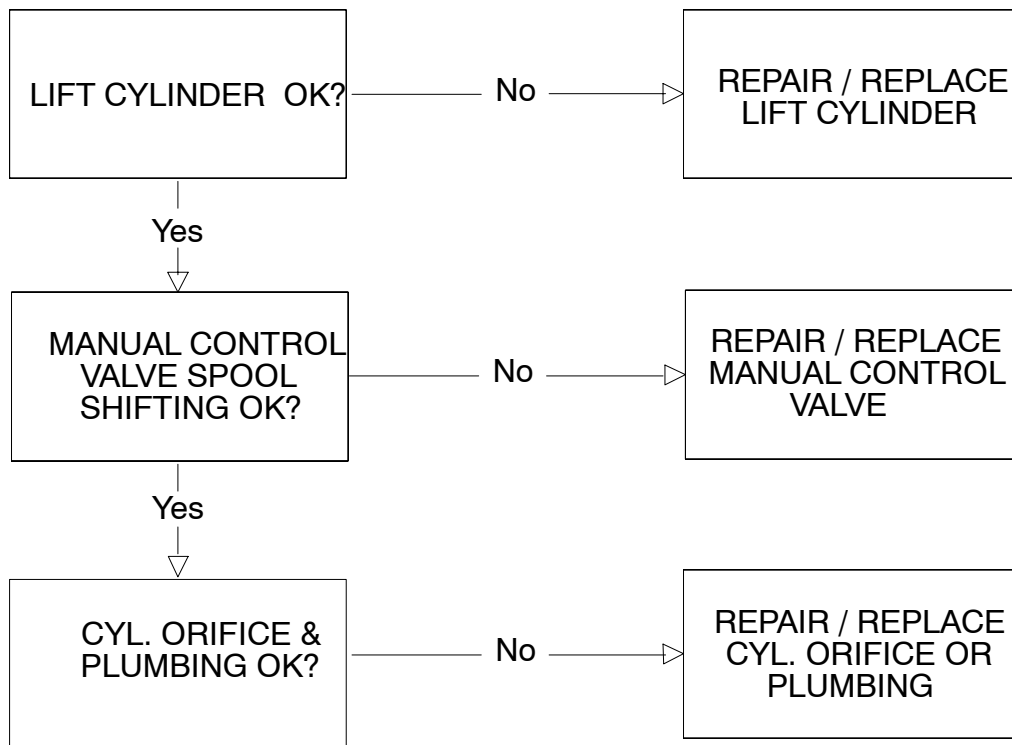

**SCRUB HEAD WILL NOT GO OUT  
(edge scrub option)**

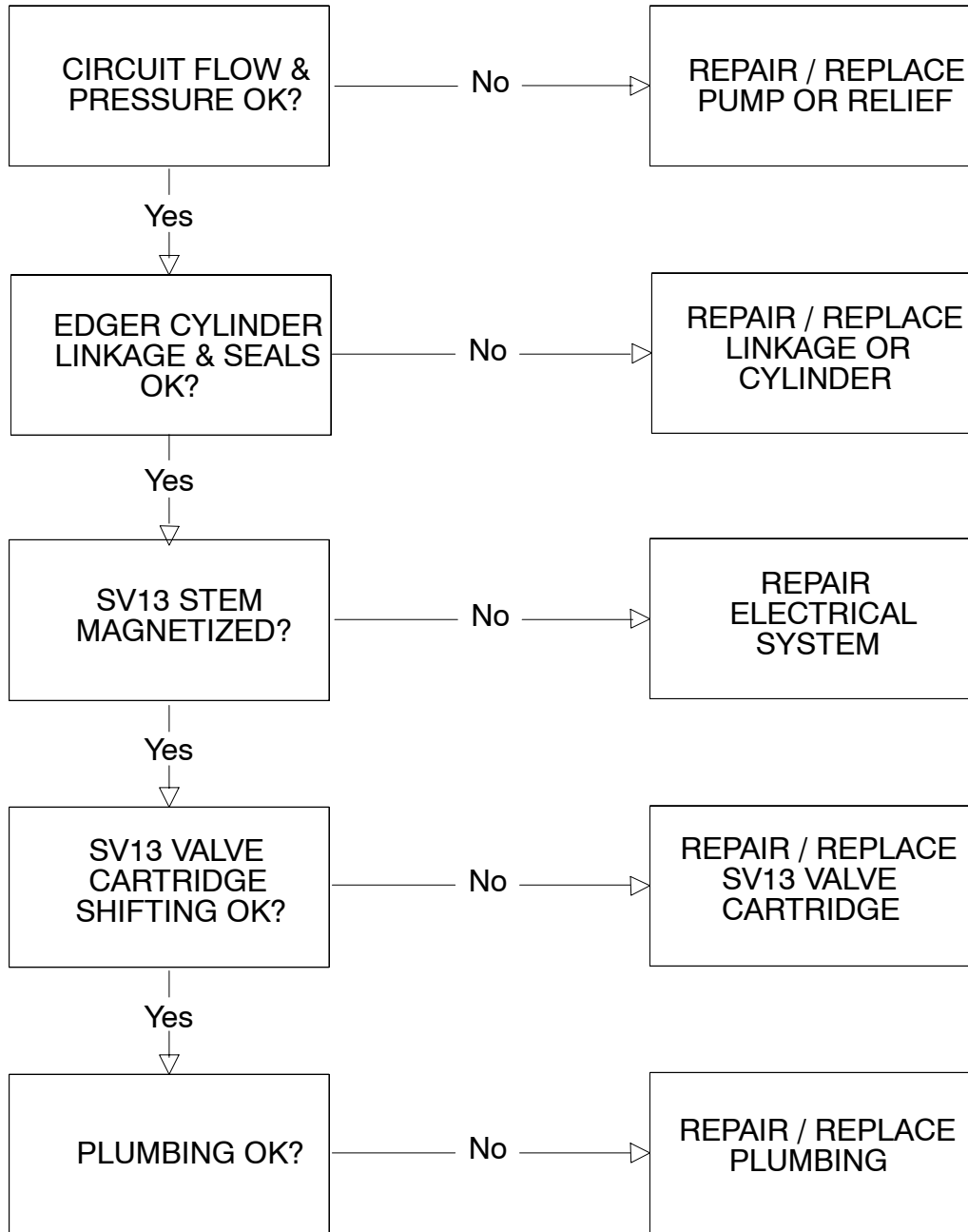



**SCRUB HEAD WILL NOT GO IN  
(edge scrub option)**

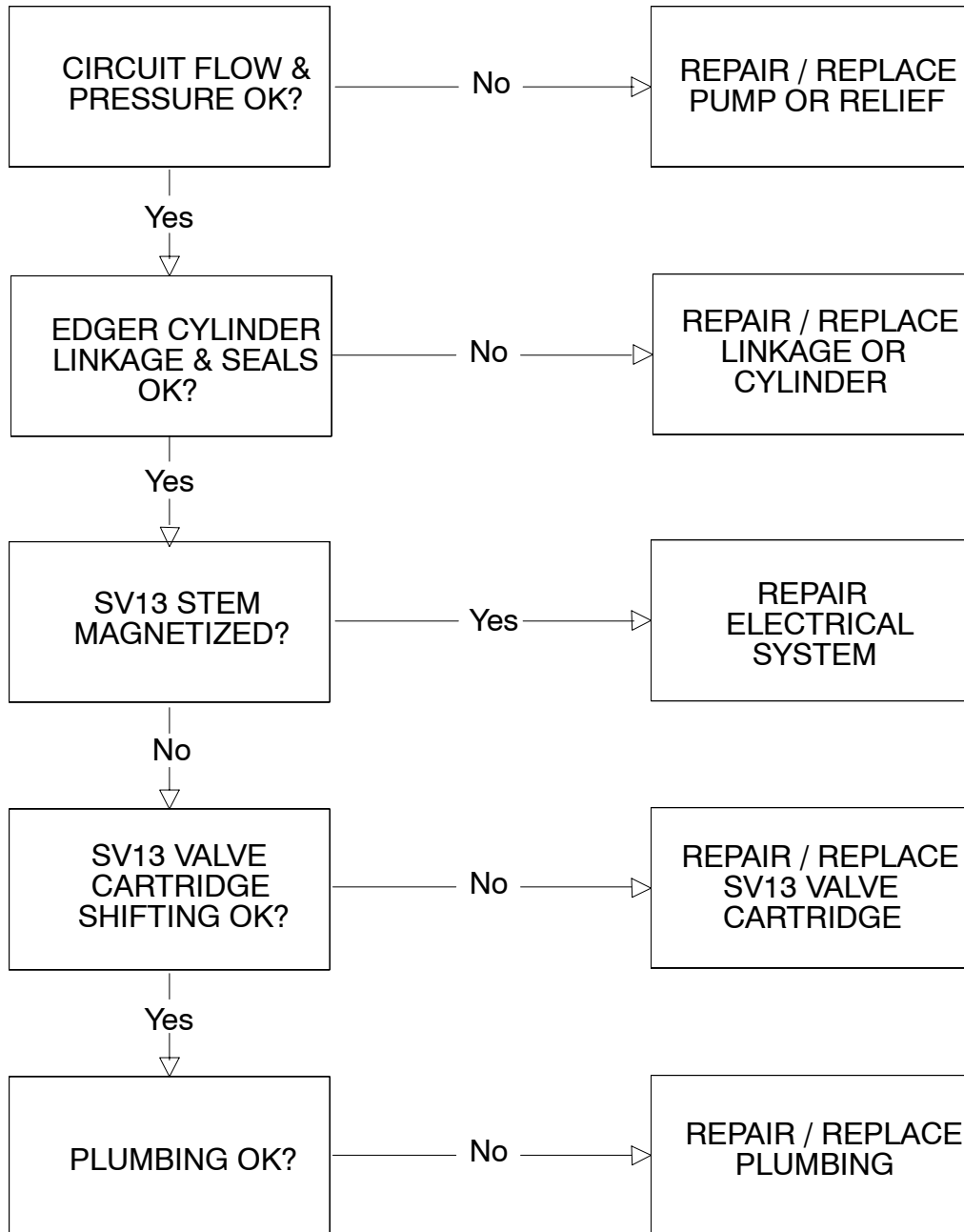

**MAIN BRUSH WILL NOT GO DOWN (8210 only)**

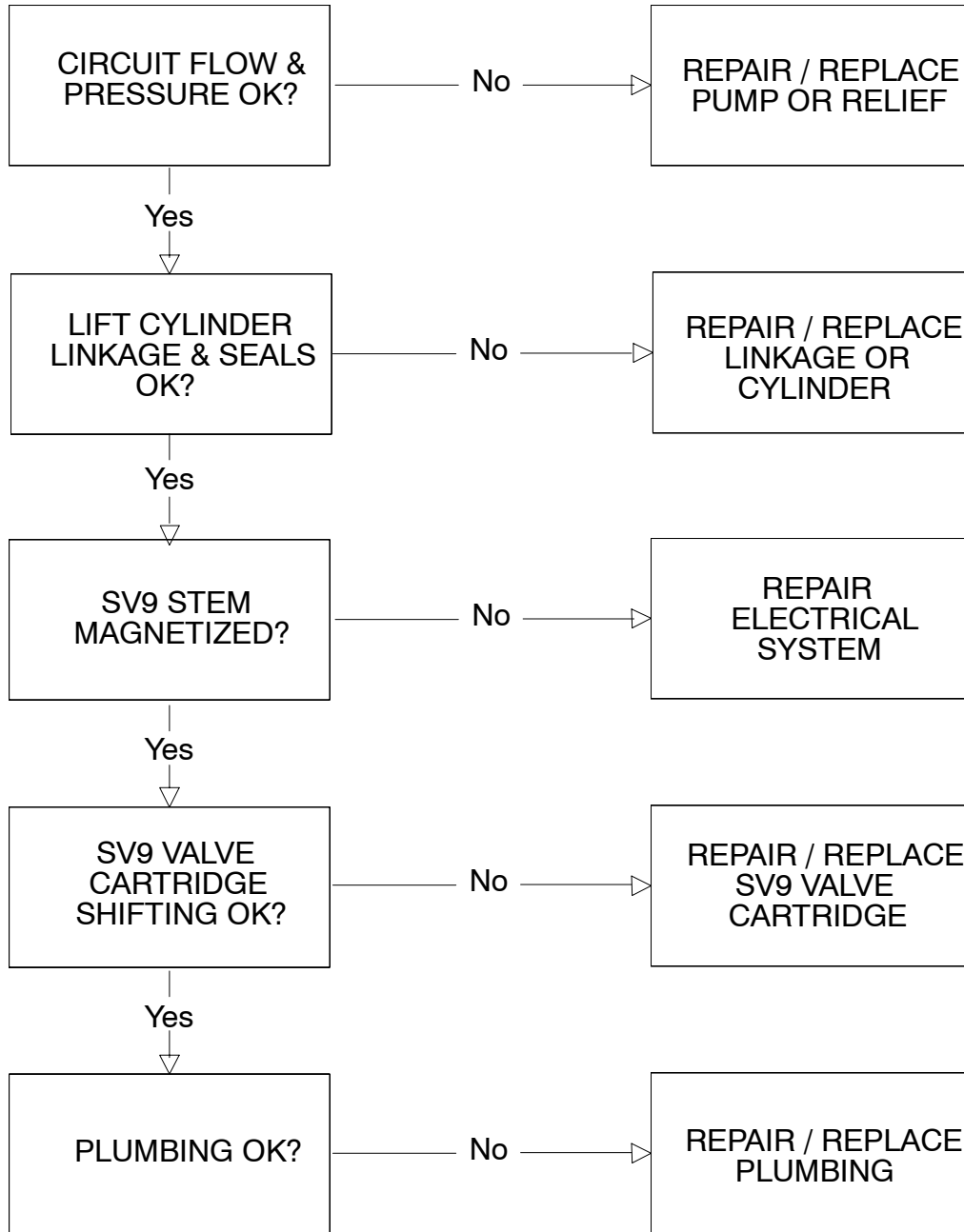

**MAIN BRUSH WILL NOT GO UP  
(8210 only)**

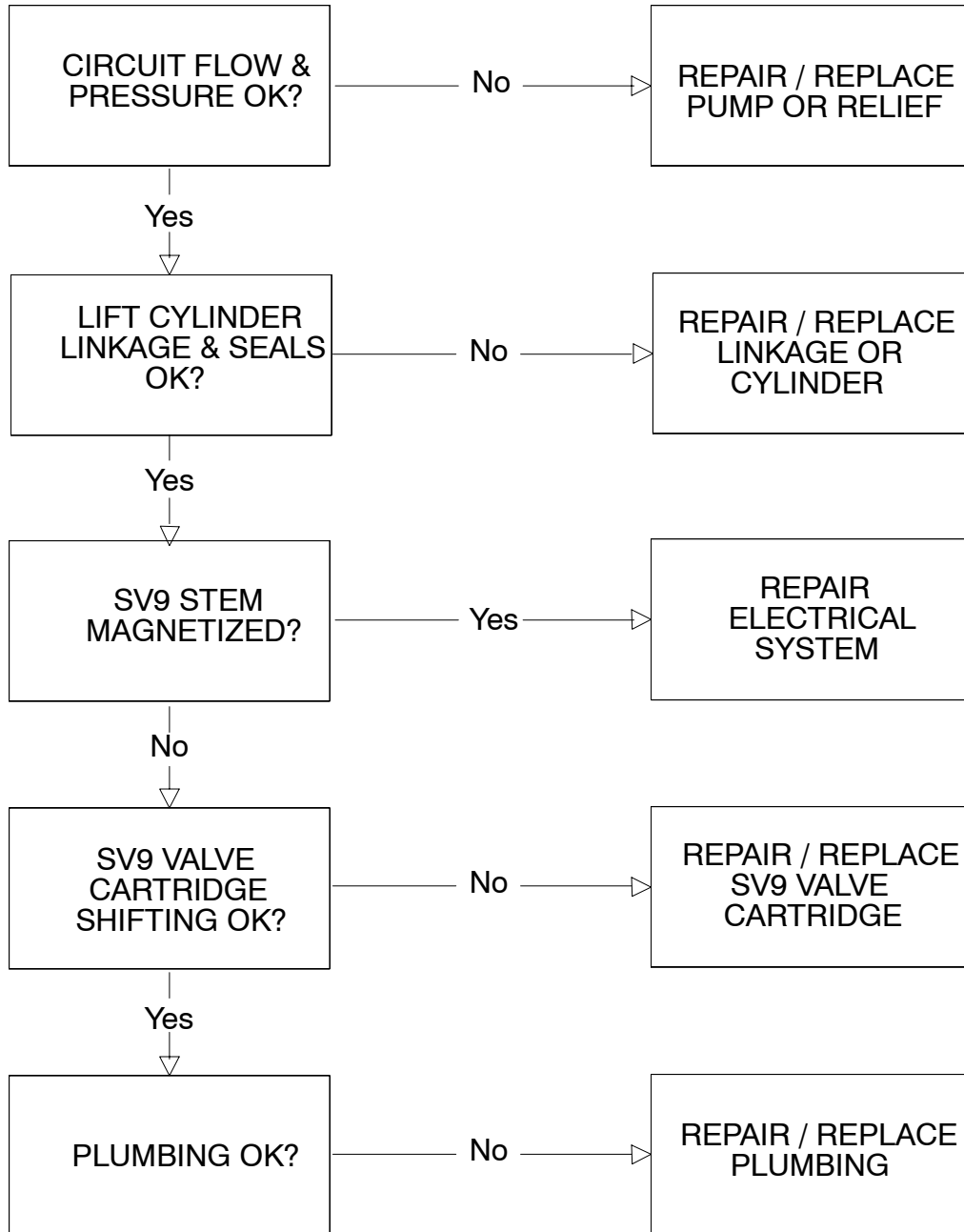

**SIDE BRUSH WILL NOT GO DOWN (8210 only)**

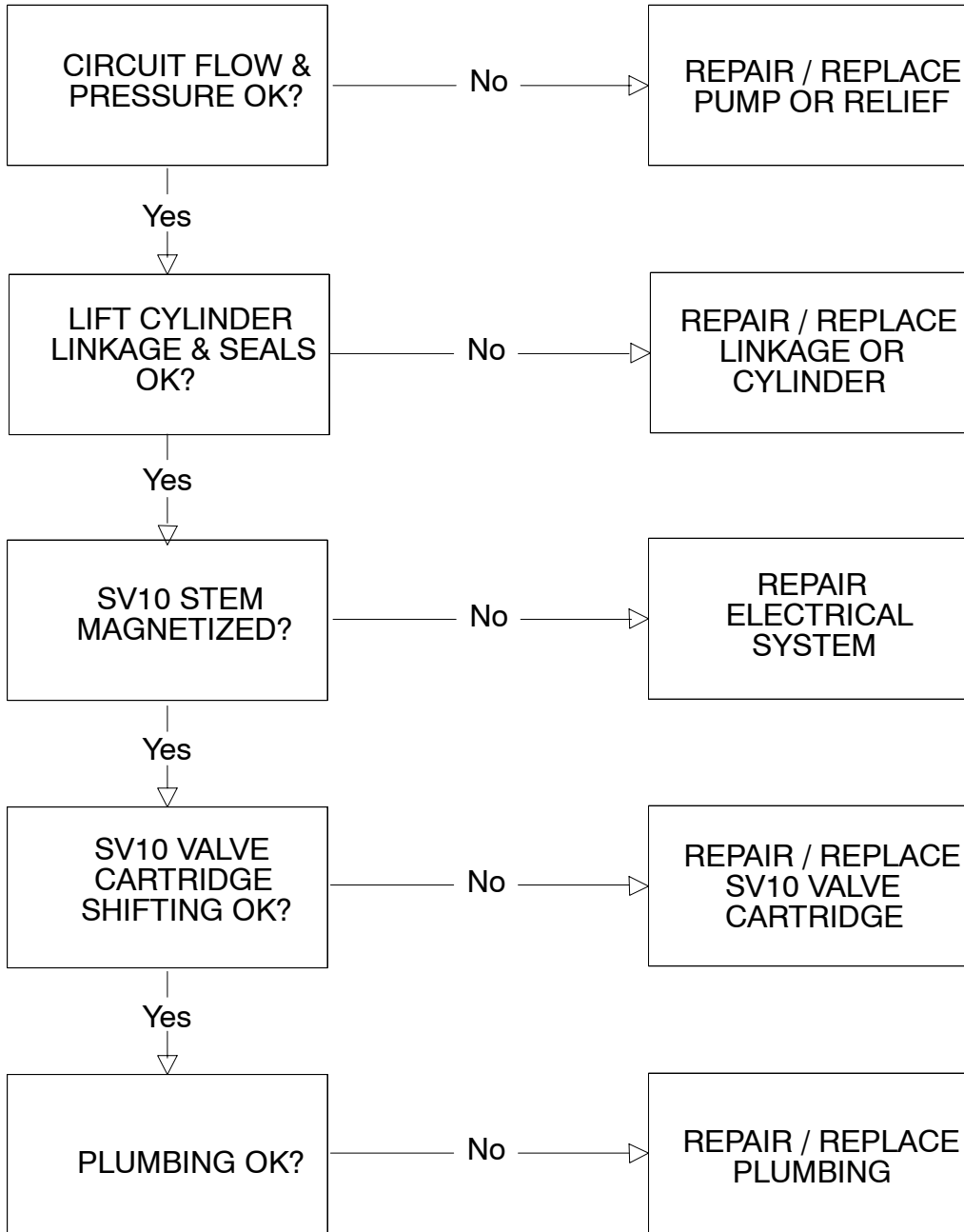

**SIDE BRUSH WILL NOT GO UP  
(8210 only)**

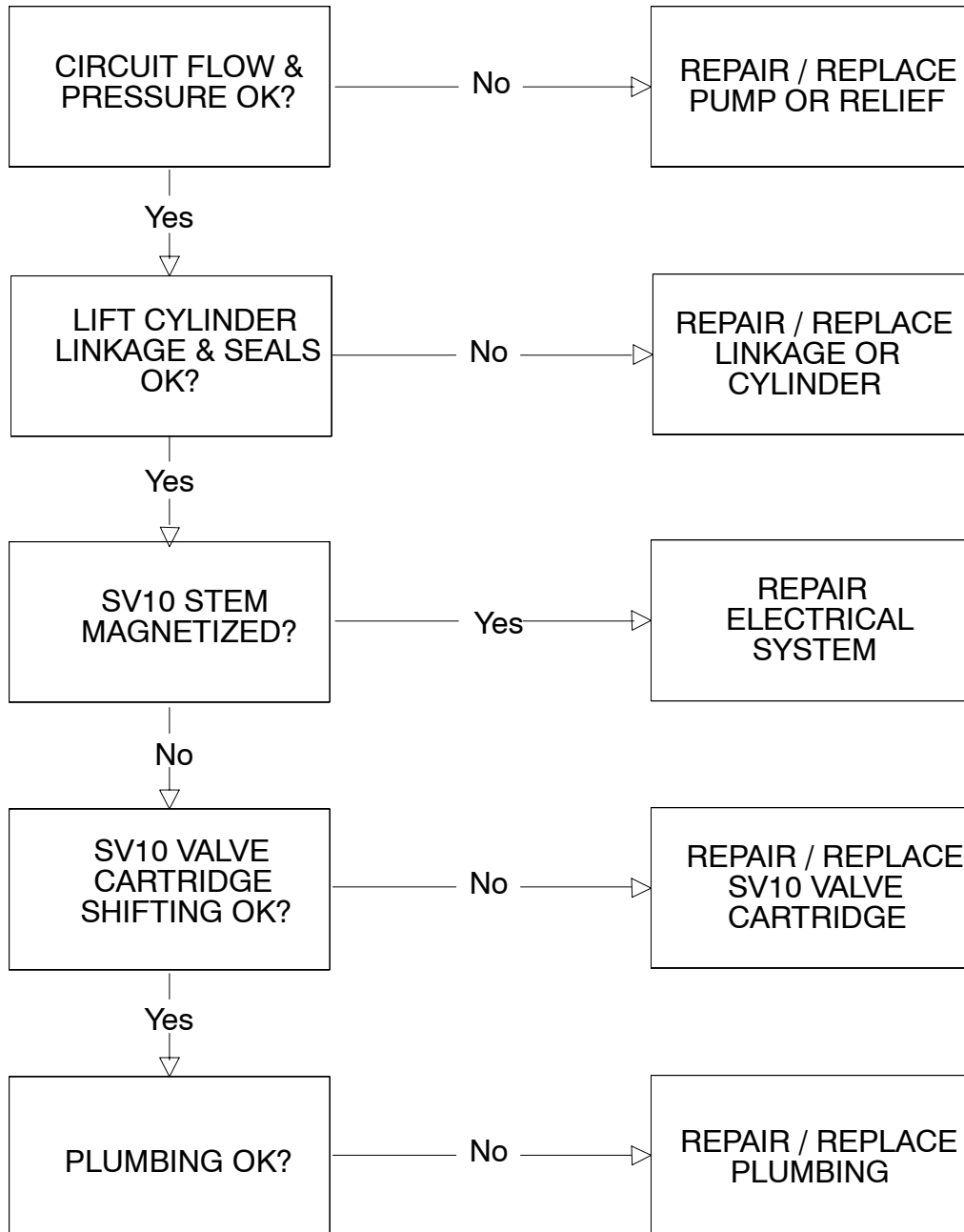

**HOPPER DOOR WILL NOT CLOSE (8210 only)**

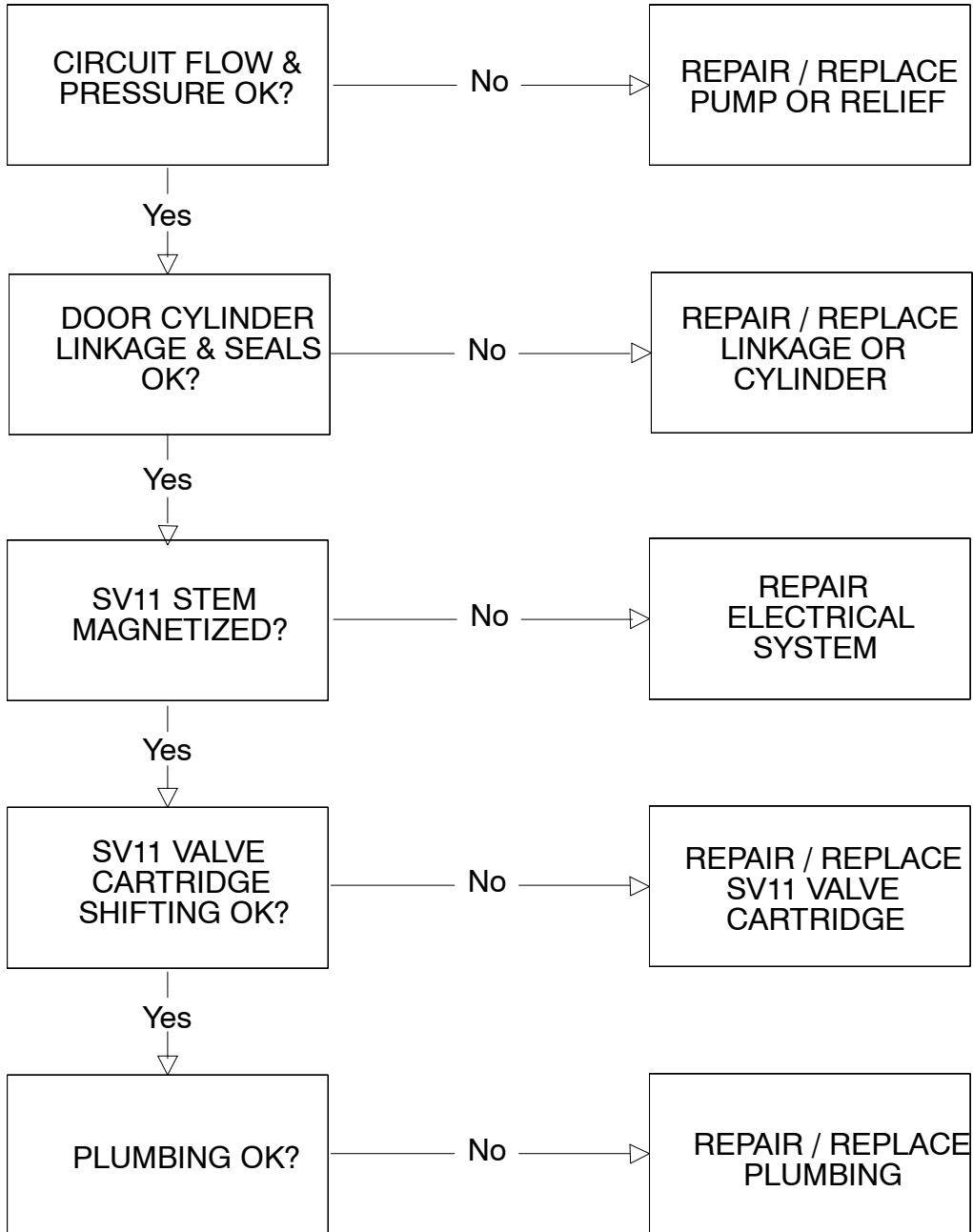

**HOPPER DOOR WILL NOT STAY CLOSED (8210 only)**

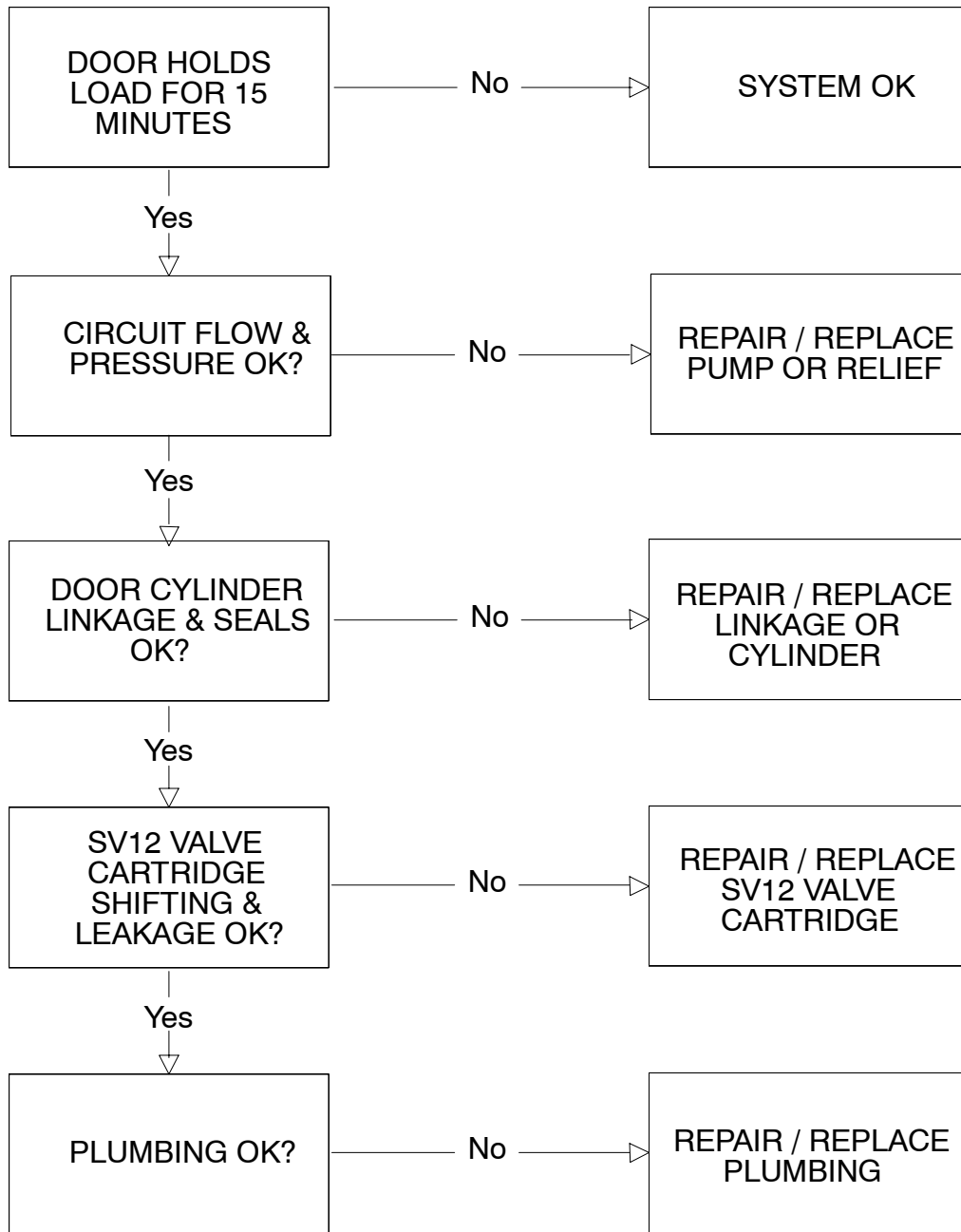

**HOPPER DOOR WILL NOT OPEN  
(8210 only)**

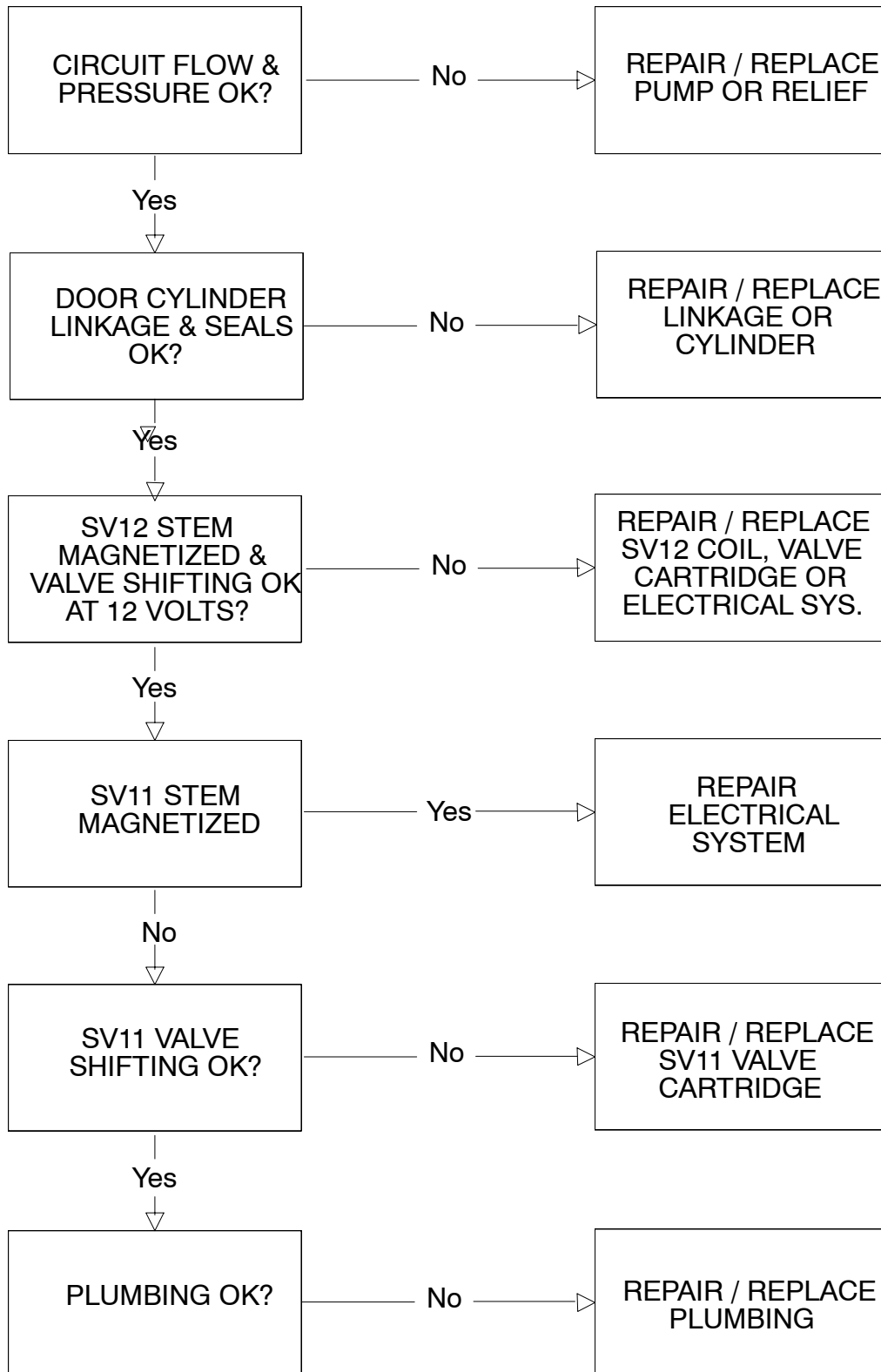



**PROPEL MOTOR WILL NOT PROPEL**

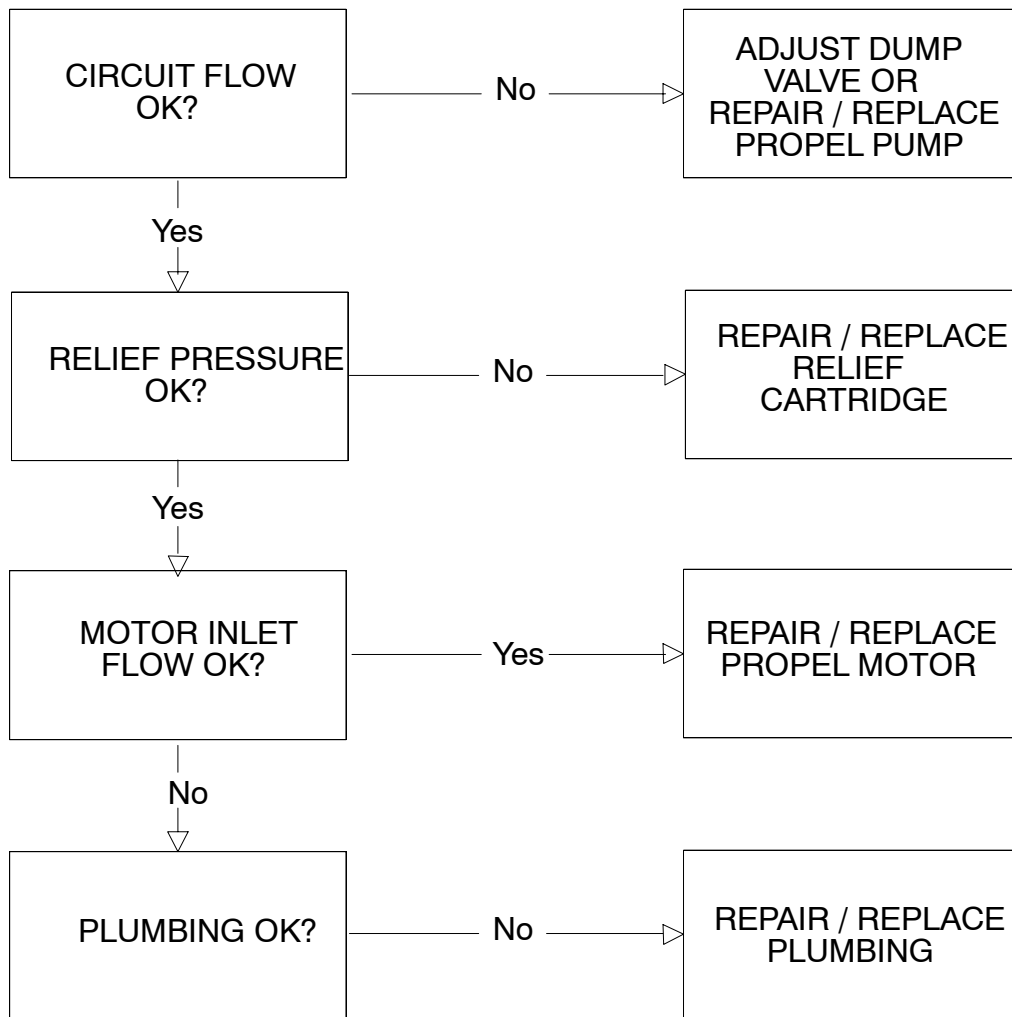



# Char-Lynn<sup>®</sup>

Disc Valve Motor

No. 7-118  
May, 1999



## Repair Information

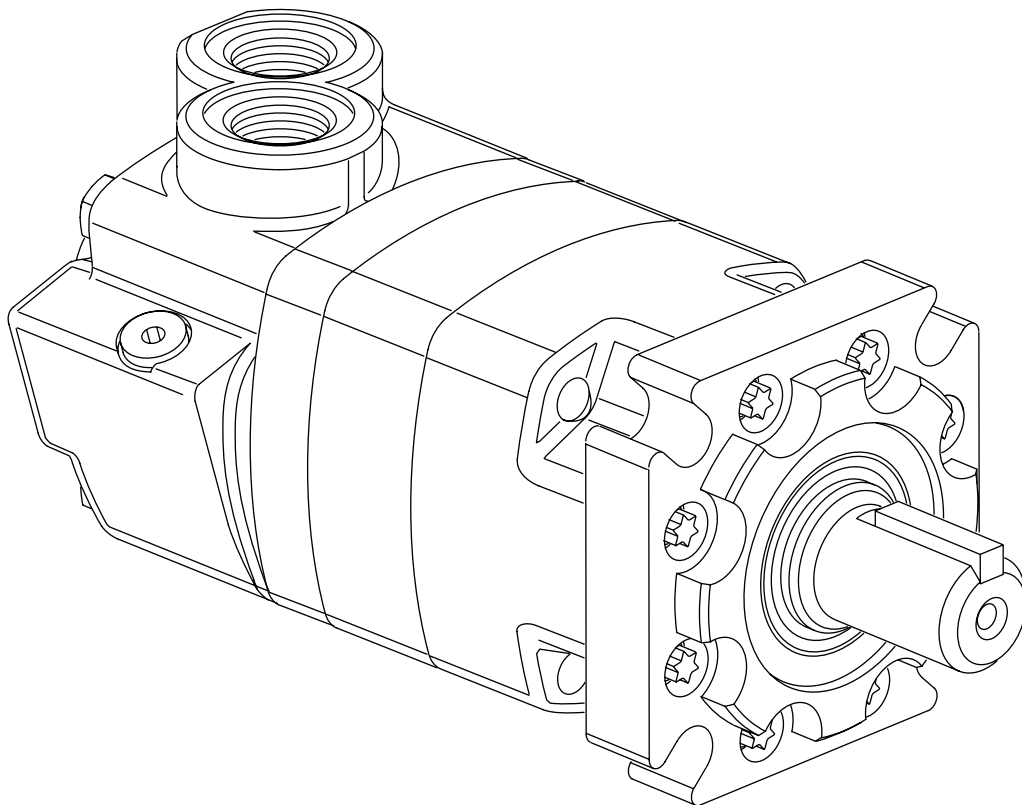

4000 Series  
Geroler<sup>®</sup> Motors

Std., Whl. and Brgl. **-004** Std. and Whl. **-006**



# Tools

Wheel motor and bearingless motor repair information on page 9 and 10.  
 Shuttle valve and seal guard repair information on page 10.  
 Seal guard reference on page 10.

**Tools required for disassembly and reassembly**

- Torque wrench (68 Nm [600 lb-in] capacity)
- 300 to 400 mm [12 to 16 inch] breaker bar
- 3/4 inch and 1/2 inch sockets
- Small screwdriver (150 to 200 mm [6 to 8 inch] long, 6 mm [.25 inch] blade)
- 3/16 inch Hex Key
- Hydraulic press — 1335 N [300 lbf]
- Shaft face seal (-004) installation tool 600468
- Shaft face seal (-006) installation tool 600421-2
- \* — Bullet (600463) for 1-1/4 inch diameter shafts
- Shaft seal installation tool (2 -1/4 inch socket)
- Torq wrench required for eight mounting flange screws (replacement screws or -006 design) No. E10

**The following tools are not necessary for disassembly and reassembly but are extremely helpful**

- Alignment studs (2), see dimensions below

\* Available by special order, contact Eaton Corp., Hydraulics Division Service Dept.

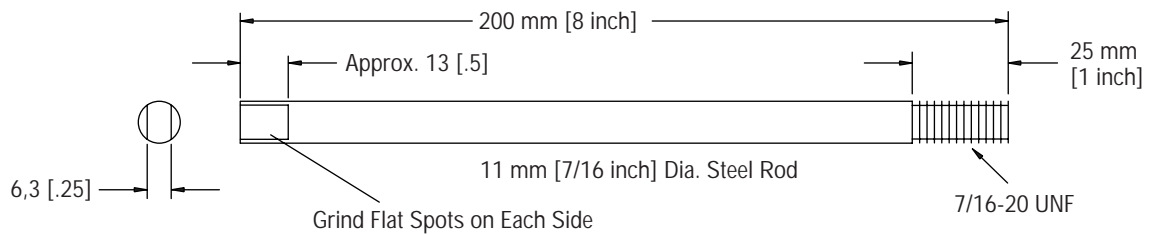

# Disassembly

Cleanliness is extremely important when repairing a hydraulic motor. Work in a clean area. Before disconnecting the lines, clean port area of motor thoroughly. Use a wire brush to remove foreign material and debris from exterior joints of motor. Check shaft and keyway. Use 600 grit paper/cloth to remove all nicks, burrs, and sharp edges that might damage the shaft seals when installing retainer on shaft and bearing assembly. Before starting disassembly procedures, drain oil from inside of motor.

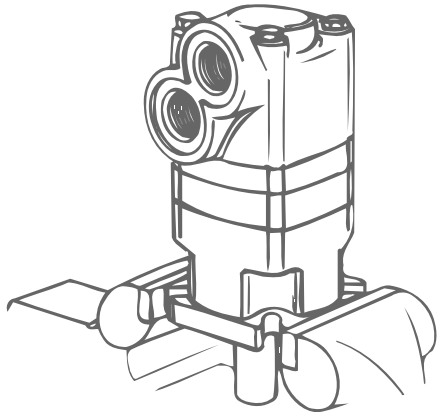

Figure 1

1 Place motor in a vise with output shaft down. Clamp across edge of mounting flange, not on housing (see Figure 1). Excessive clamping pressure will cause distortion. When clamping, use some protective device on vise, such as special soft jaws, pieces of hard rubber or board.

**Although not all drawings show the motor in a vise, it is recommended that you keep the motor in the vise during disassembly. Follow the clamping procedures explained throughout the manual.**

2 Remove 4 bolts from the valve housing.

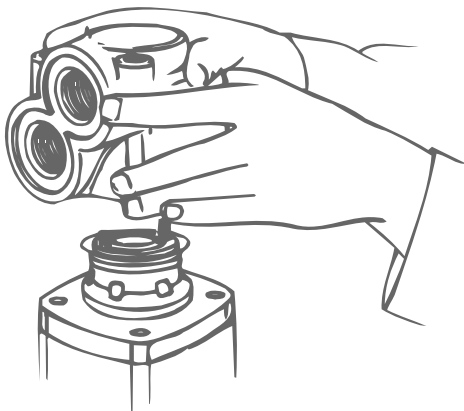

Figure 2

3 Lift valve housing straight up. If done carefully, the springs and balance ring subassembly will remain on valve for easy removal.

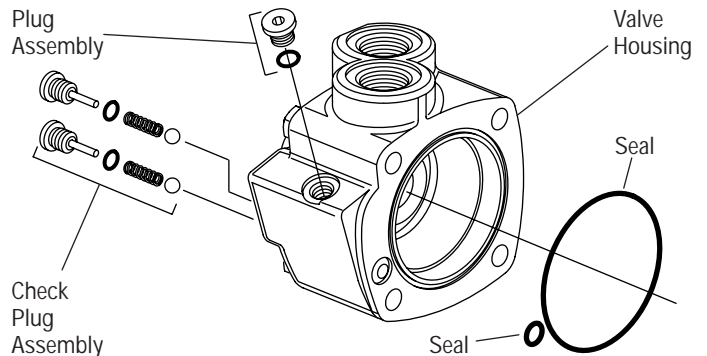

Figure 3

4 Carefully remove the following from the valve housing:

- 1 seal, 82,3 mm [3.24 inch] I.D.
- 1 seal, 8,9 mm [.35 inch] I.D.
- 2 check valve plug assemblies (plug, seal, spring, ball) 1 plug (case drain) with seal.

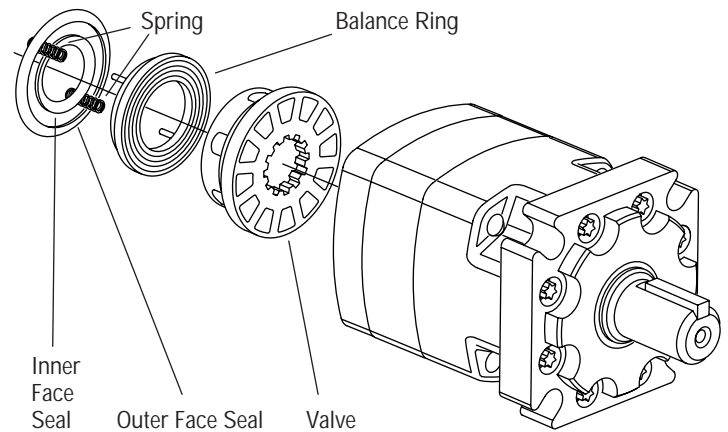

Figure 4

5 Remove 2 balance ring springs.

6 Remove balance ring subassembly.

7 Remove inner and outer face seals from the balance ring.

8 Lift off valve.

# Disassembly

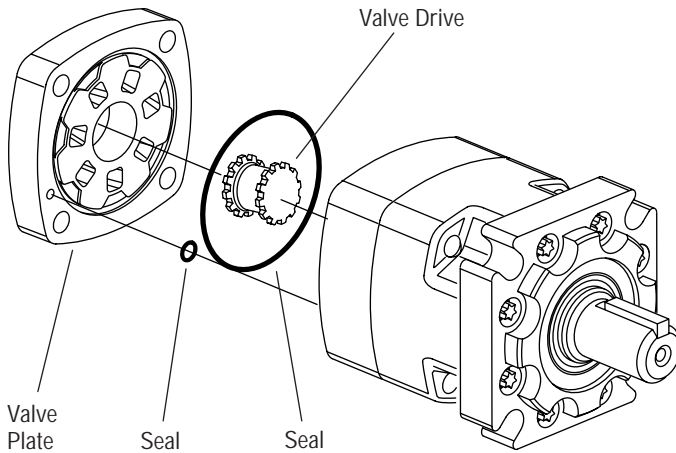

Figure 5

9 Remove valve plate.

10 Remove 88,6 mm [3.49 inch] I.D. seal from valve plate (see Figure 5).

11 Remove valve drive (see Figure 5).

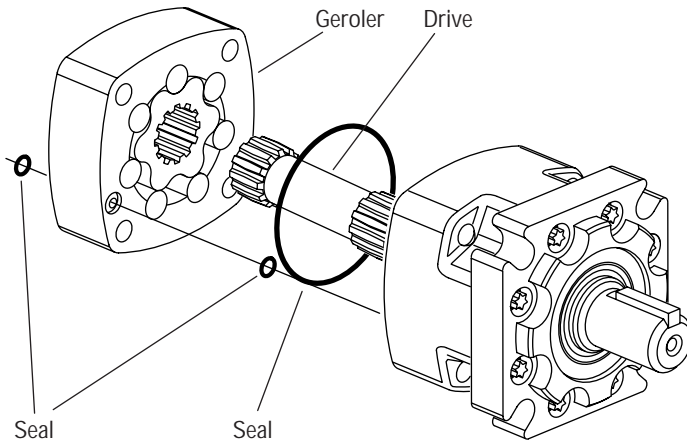

Figure 6

12 Remove Geroler. Retain rollers in outer Geroler ring if they are loose.

13 Remove 2 seals from Geroler, 1 seal on each side of Geroler.

14 Remove drive.

15 Remove 88,6 mm [3.49 inch] I.D. seal from bearing housing.

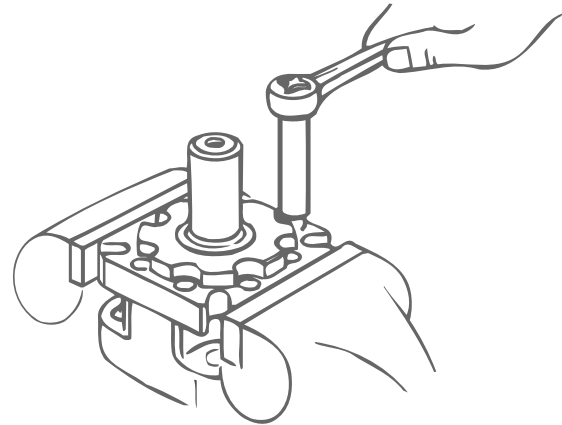

Figure 7

16 Use a stud remover or vise grips to remove studs (earlier models only). Clamp bearing housing in vise as shown in Figure 7. Loosen 8 screws. Remove screws, washers (discard washers, as they are not required for reassembly), and mounting flange (see Figure 8).

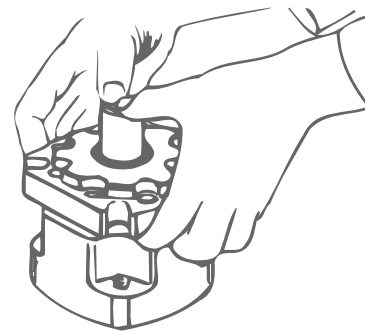

Figure 8

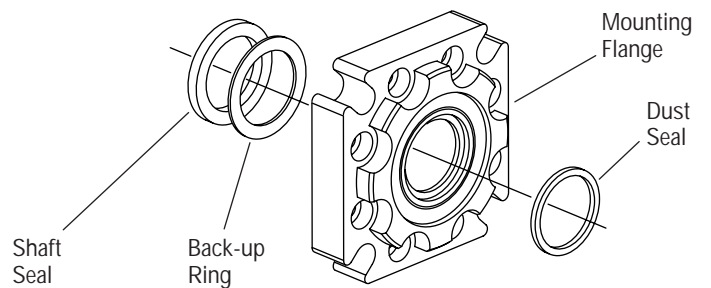

Figure 9

17 Remove shaft seal, back-up ring (if used) and dust seal from flange. Use a small screwdriver to remove dust seal. Do not damage bore of flange.

## Disassembly

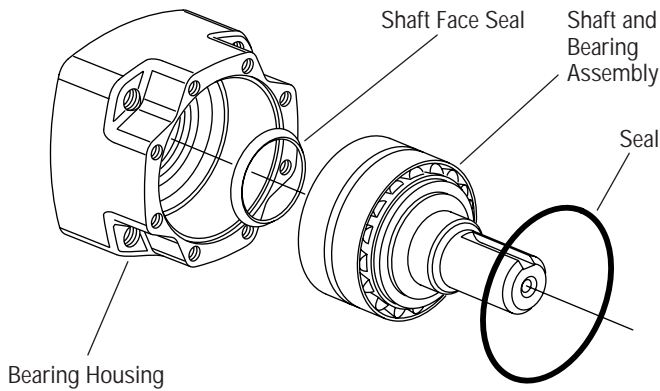

Figure 10

18 Remove shaft and bearing assembly. You may need a press to remove shaft and bearing assembly (see Figure 10).

19 Remove shaft face seal from bore of bearing housing (see Figure 10). Do not damage bore of bearing housing.

**Note: Individual parts of the shaft and bearing assembly are not sold separately and must be replaced as a unit.**

## Reassembly

Check all mating surfaces. Replace any parts that have scratches or burrs that could cause leakage. Clean all metal parts in clean solvent. Blow dry with air. Do not wipe with cloth or paper towel because lint or other matter could get into the hydraulic system and cause damage. Do not use a coarse grit papers/cloth or try to file or grind motor parts. Check around the keyway and chamfered area of the shaft for burrs, nicks, or sharp edges that can damage the seals when reassembling the retainer.

**Note: Lubricate all seals (prior to installation) with petroleum jelly such as Vaseline®. Use new seals when reassembling the motor.**

**Note: Shaft face seal installation tool is available by special order. Contact Eaton Corporation, Hydraulics Division (Service Department). 600468 (-004) 600421-2 (-006).**

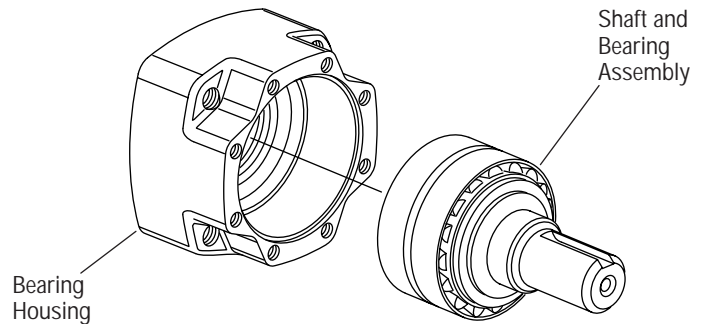

Figure 12

22 Install shaft and bearing assembly in bearing housing (see Figure 12). Do not damage seal in bore of housing. You may need a press to install shaft and bearing assembly.

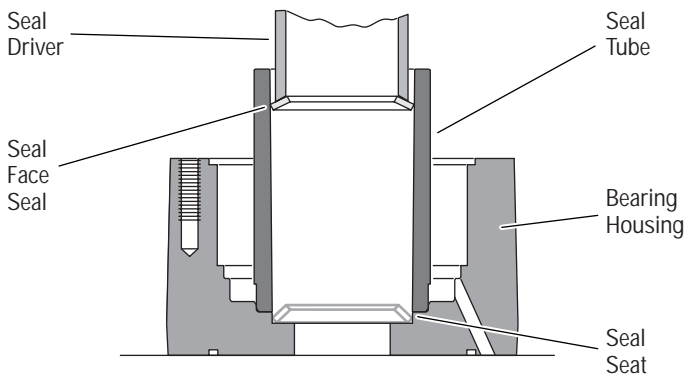

Figure 11

21 Place bearing housing on smooth flat surface with largest open end of housing up. Apply petroleum jelly to shaft face seal. Install seal in seal seat. Seat seal properly in groove (see Figure 11). A damaged or improperly installed shaft face seal could cause internal lubrication loss and subsequent parts wear.

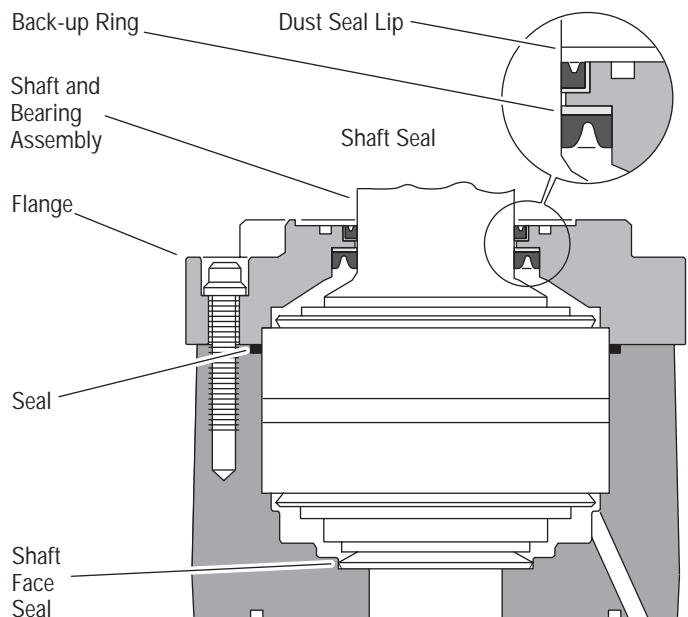

Figure 13



# Reassembly

23 Apply petroleum jelly to 88,6 [3.49] ID seal. Install seal in seal groove of bearing housing (see Figure 13).

24 Use a small press, if available, to install dust seal in retainer. Metal side of dust seal must face toward flange, as shown in Figure 13. If a press is not available, use a plastic or rubber hammer to tap dust seal in place.

25 Install 92,1 [3.62] ID seal, back-up ring and shaft seal in retainer. Flat or smooth side of shaft seal must face toward retainer as shown in Figure 13. Apply petroleum jelly to inside diameter of shaft seal (after installing seal).

26 Before installing retainer, place a protective sleeve of bullet (see note below) over shaft. Grease inside diameter of dust and shaft seals. To prevent damage to seals, install retainer over shaft with a twisting motion. Do not cut or distort shaft seal. Damage to shaft seal will cause external leakage.

**Note: Bullet 600463 for 1-1/4 inch diameter shafts available by special order through Eaton Hydraulics Division service department.**

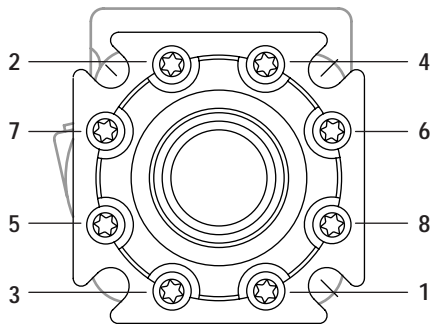

Figure 14

27 Lubricate threads of 8 screws with a film of light oil. Install and finger tighten screws. Clamp bearing housing in vise. Torque screws to 6 Nm [50 lb-in] in sequence (see Figure 14). Then final torque to 34 Nm [300 lb-in], in sequence. Install key (when used) in keyway of shaft.

**Note: Full torque 34 Nm [300 lb-in] on one bolt at a time can damage bolt or retainer.**

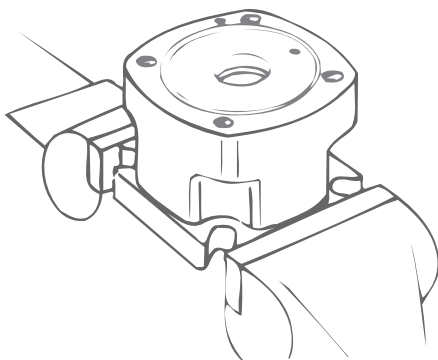

Figure 15

28 Reposition motor in vise with output shaft down. Clamp across edges of retainer as shown in Fig. 15.

29 Pour a small amount of light oil inside the output shaft.

30 Apply a light film of petroleum jelly on 88,6 mm [3.49 inch] I.D. seal. Install seal in bearing housing.

31 Install drive in output shaft (insert longer splined end of drive first), (see parts drawing on page 2).

32 To help in the reassembly procedure, it is recommended using two alignment studs (see special tools page 3) diagonally opposed in the four bolt holes of the bearing housing.

33 Apply petroleum jelly on 2 seals, 9,3 mm [.25 inch] I.D. Install seals (1 on each side of Geroler) in case drain grooves of Geroler.

**Note: Installation at this point involves 3 steps in timing the motor. Timing determines the direction of rotation of the output shaft.**

Timing parts include:

1. Geroler
2. Valve drive
3. Valve Plate
4. Valve

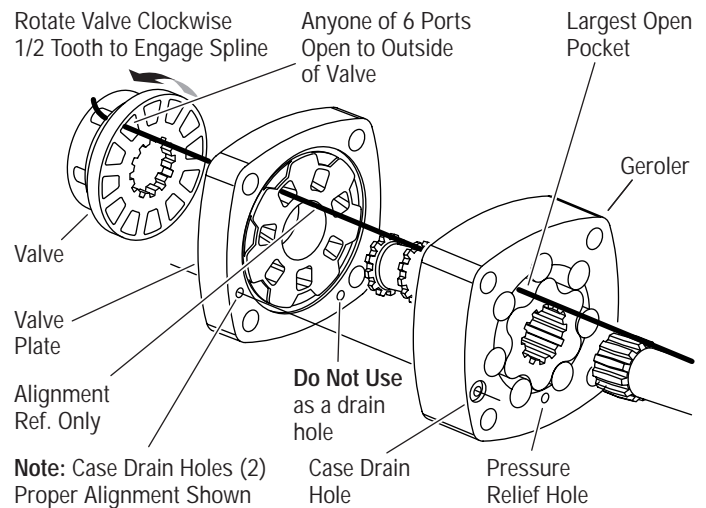

Figure 16 Timing Alignment

**Timing Step No. 1** — Locate largest open pocket in Geroler. Then mark location of pocket on outside edge of Geroler (see Figure 16).

34 Align case drain hole and pressure relief hole in Geroler with case drain hole and pressure relief hole in bearing housing. Install Geroler on bearing housing (see Figure 16). Retain rollers in outer Geroler ring if they are loose.

35 Install valve drive in Geroler.

# Reassembly

36 Apply a light film of petroleum jelly on 88,6 mm [3.49 inch] I.D. seal. Install seal in valve plate.

37 Align case drain hole in valve plate with case drain hole in Geroler. Install valve plate (seal side toward Geroler) on Geroler as shown in Figure 16.

**Timing Step No. 2** — Locate slot opening in valve plate which is in line with largest open pocket of Geroler (see Figure 16).

38 Use the following procedure for installing the valve on the valve plate.

**Timing Step No. 3** — Locate any one of the side openings of the valve that goes through to the face of the valve. **Line up this side opening in the valve with open slot of valve plate that is in line with largest open pocket of Geroler.** Rotate valve clockwise (1/2 spline tooth) to engage valve with the valve drive spline, alignment reference shown in Figure 17 (above). This procedure provides standard timing when pressurized as shown in Figure 17.

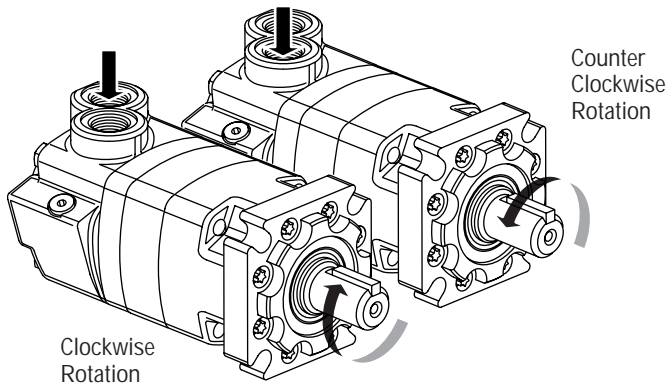

Figure 17

39 Apply clean grease on balance ring assembly springs. Install springs in 2 holes located inside bore face of valve housing (see Figure 18).

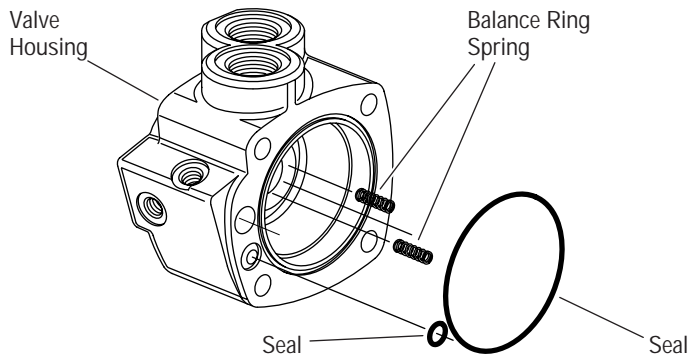

Figure 18

40 Apply a light film of petroleum jelly on 8,9 mm [.35 inch] I.D. seal. Install seal in case drain groove of valve housing.

41 Apply a light film of petroleum jelly on 82,3 mm [3.24 inch] I.D. seal. Install seal in outside seal groove of valve housing.

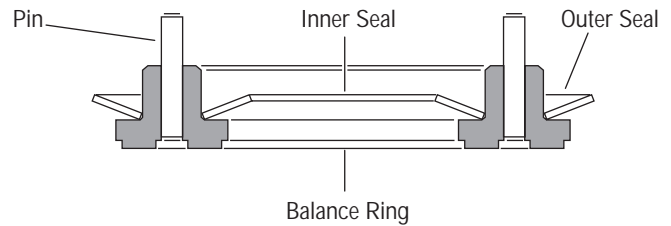

Figure 19

42 Apply petroleum jelly on inner and outer face seals. Install seals on balance ring as shown in Figure 19.

**Important:** Install face seals in the positions shown in Figure 19 or the motor will not operate properly. Do not force or bend these face seals. Any damage to these seals will affect the operation of the motor.

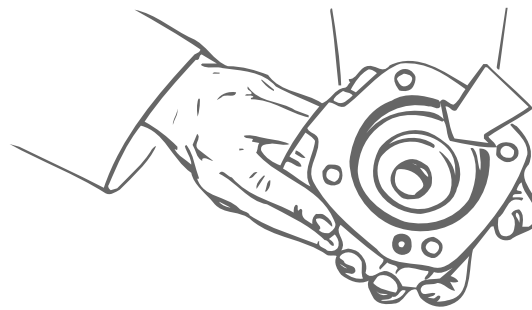

Figure 20

43 Align 2 pins of balance ring with 2 spring holes in valve housing as shown in Figure 20 . Install balance ring in valve housing.

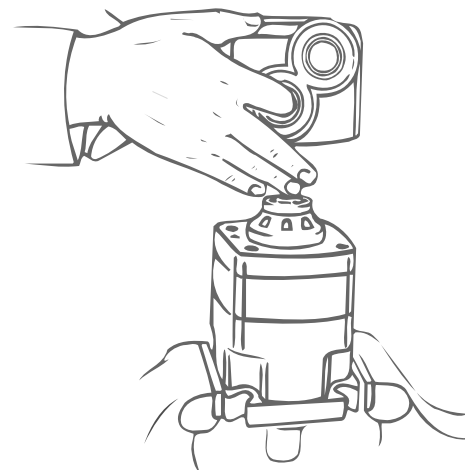

Figure 21

## Reassembly

44 Insert your finger through port of housing. Apply pressure to side of balance ring assembly. Hold ring in position until valve housing is in place (see Figure 21). Align case drain hole in housing with case drain hole in valve plate. Install valve housing against valve plate (see Figure 22).

**Note:** After installing valve housing on valve plate, check between body parts of motor for unseated seals.

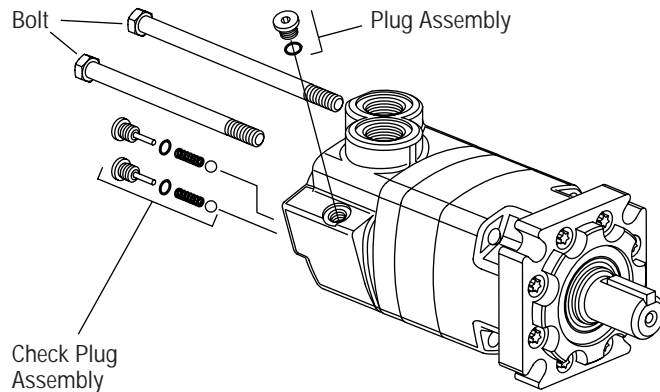

Figure 22

45 Install and finger tighten 2 bolts (or studs for earlier models) opposite alignment studs. Remove alignment studs and install remaining bolts (or studs and 4 nuts for earlier models). Torque bolts (or nuts) to 85 Nm [750 lb-in], in sequence (see Figure 23).

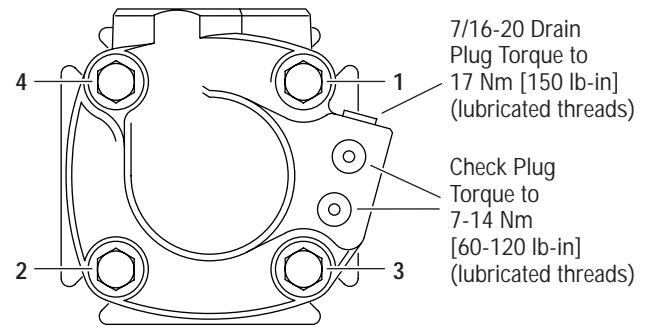

Figure 23

46 Install 2 check plug assemblies (ball, spring, plug with seal). Also install case drain plug with seal, parts shown in Figure 22 (plug torque shown in Figure 24).

## Wheel Motors

A different bearing housing is used on wheel motors (see Figure 24). Other than this, the parts are the same as the standard motor and the same disassembly and reassembly procedures apply.

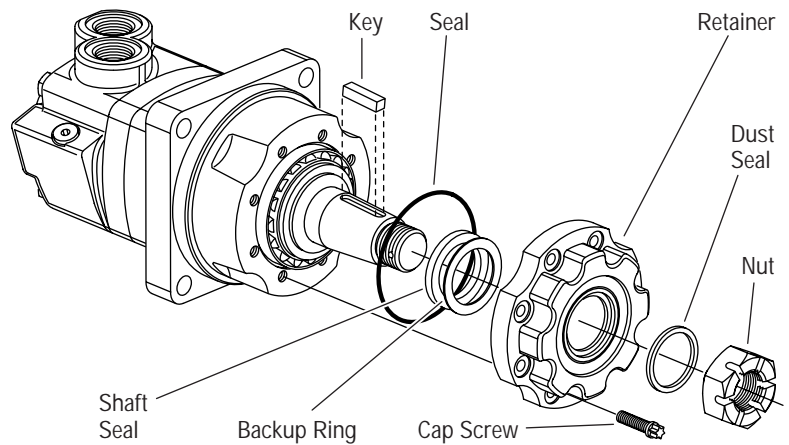

Figure 24

## Bearingless Motors

This motor is the same as the standard without the shaft/bearing assembly, bearing housing and retainer. The mounting flange replaces the bearing housing (see Figure 25). Follow same disassembly and reassembly procedures as rear section of standard motor.

**Important:** Loctite® information for bearingless motor on page 10.

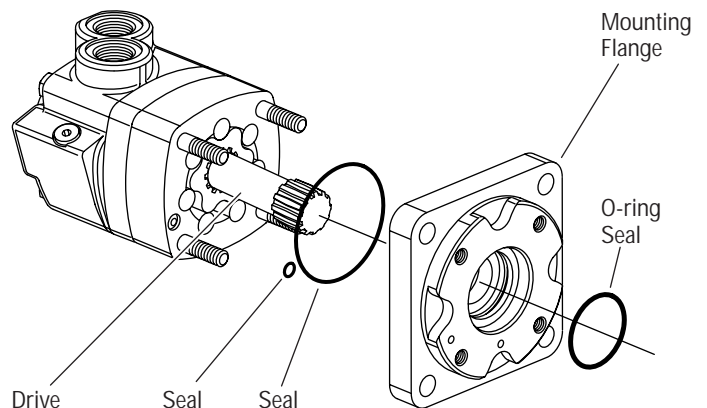

Figure 25

# Reassembly

**Important:** This motor requires Loctite in threaded holes of mounting flange.

Follow these procedures:

Adequate Loctite penetration and sealing depend highly on cleanliness and dryness of threads. Use a non-petroleum base solvent to clean excess oil from threads of flange after disassembly. You may need to use a tap to clean threads of excess old Loctite. After you have fully reassembled the motor, apply 2 to 3 drops of Loctite no. 290 at top of threaded holes (see Figure 26).

Note: Allow Loctite 5 minutes for thread penetration before installing motor on gear case.

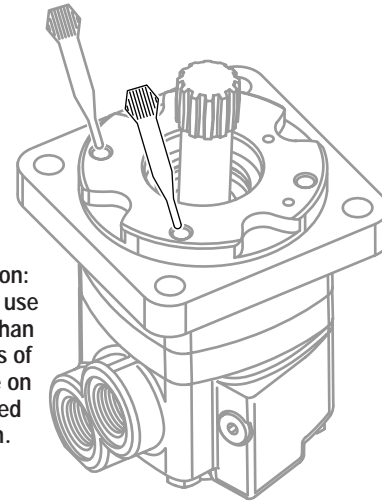

**Attention:** Do not use more than 3 drops of Loctite on threaded portion.

Figure 26

## Motors with Shuttle and, or Seal Guard

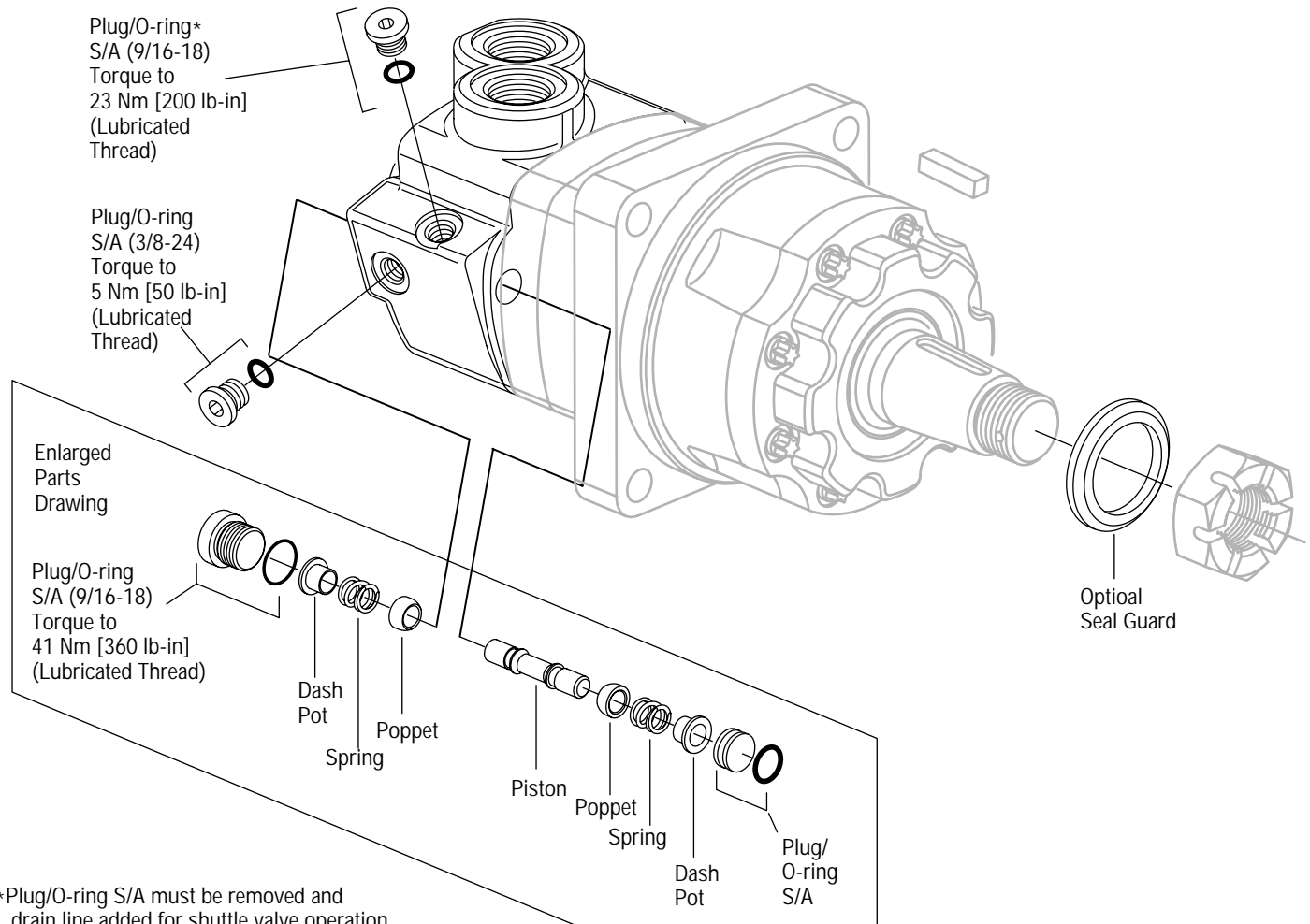

**How to Order Replacement Parts**

**Each Order Must Include the Following:**

- 1. Product Number
- 2. Date Code
- 3. Part Name
- 4. Part Number
- 5. Quantity of Parts

For more detailed information contact Eaton Corp. Hydraulics Division 15151 Highway 5 Eden Prairie, MN 55344.

- Specifications and performance data, Catalog No. 11-878.
- Replacement part numbers and kit information — Parts Information No. 6-126.

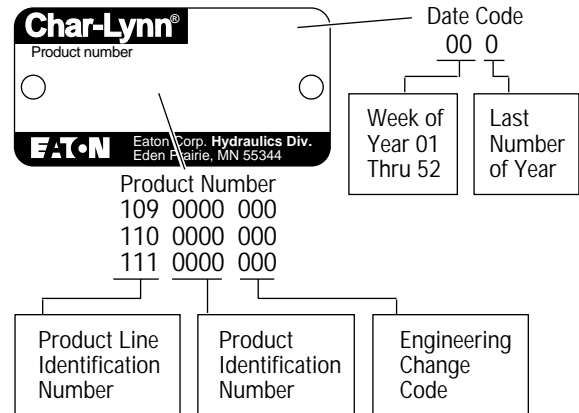

**Product Numbers—4000 Series Motors**

Use digit prefix —109-, 110-, or 111- plus four digit number from charts for complete product number—Example 111-1057.  
**Orders will not be accepted without three digit prefix.**

Mounting	Shaft	Ports	Displ. cm <sup>3</sup> /r [ in <sup>3</sup> /r] Product Number								
			110 [ 6.7]	130 [ 7.9]	160 [ 9.9]	205 [12.5]	245 [15.0]	310 [19.0]	395 [24.0]	495 [30.0]	625 [38.0]
Standard SAE B-Mount	1-1/4 inch Straight	1-1/16 O-ring	109-1100	-1101	-1102	-1103	-1104	-1105	-1106	-1212	-1215
		3/4 inch Split Flange	109-1001	-1054	-1002	-1003	-1055	-1056	-1057	—	—
	1-5/8 Inch Tapered	1-1/16 O-ring	109-1107	-1108	-1109	-1110	-1111	-1112	-1113	—	—
		3/4 inch Split Flange	109-1006	-1058	-1007	-1008	-1059	-1060	-1061	—	—
	1-1/4 Inch 14 T Splined	1-1/16 O-ring	109-1114	-1115	-1116	-1117	-1118	-1119	-1120	—	—
		3/4 inch Split Flange	109-1011	-1062	-1012	-1013	-1063	-1064	-1065	—	—
Standard SAE C-Mount	40 mm Straight	G 3/4 (BSP)	109-1184	-1185	-1227	-1224	-1225	-1189	-1190	—	—
	1-1/2 Inch 17 T Splined	G 3/4 (BSP)	109-1191	-1192	-1193	-1194	-1195	-1196	-1197	—	—
Wheel Motor	1-1/4 inch Straight	1-1/16 O-ring	110-1074	-1075	-1076	-1077	-1078	-1079	-1080	—	-1122
		3/4 inch Split Flange	110-1001	-1040	-1002	-1003	-1041	-1042	-1043	—	—
	40 mm Straight	G 3/4 (BSP)	110-1108	-1109	-1110	-1111	-1112	-1113	-1125	—	—
	1-5/8 Inch Tapered	1-1/16 O-ring	110-1081	-1082	-1083	-1084	-1085	-1086	-1087	1116	-1117
		3/4 inch Split Flange	110-1006	-1044	-1007	-1008	-1045	-1046	-1047	—	—
	1-1/4 Inch 14 T Splined	1-1/16 O-ring	110-1088	-1089	-1090	-1091	-1092	-1093	-1094	—	—
3/4 inch Split Flange		110-1011	-1048	-1012	-1013	-1049	-1050	-1051	—	—	
Bearingless		1-1/16 O-ring	111-1033	-1034	-1035	-1036	-1037	-1038	-1039	-1062	-1063
		3/4 inch Split Flange	111-1044	-1015	-1045	-1046	-1016	-1017	-1018	—	—
		G 3/4 (BSP)	111-1052	-1053	-1054	-1055	-1056	-1057	-1058	—	—

111-1057

## 4000 Series Motors

Eaton Corporation  
**Hydraulics Division**  
15151 Hwy. 5  
Eden Prairie, MN 55344  
Telephone: 612/937-7254  
Fax: 612/937-7130

Sumitomo Eaton  
Hydraulic Company Ltd.  
Ooi-Cho Kameoka-Shi  
621-0017 Kyoto  
Japan  
Telephone: [+81] 771-22-9601  
Fax: [+81] 771-29-2020

Eaton Ltd.  
**Hydraulics Division**  
Glenrothes, Fife  
Scotland, KY7 4NW  
Telephone: [+44] (0)1592-771-771  
Fax: [+44] (0)1592-773-184

Eaton Ltd.  
7th Floor, Woo Duk Building  
832-2 Yeoksam-Dong, Kangnam-Ku  
Seoul 135-750  
Korea  
Telephone: [+82] 2-557-0595  
Fax: [+82] 2-557-1634

Eaton B.V.  
Boeing Avenue 11  
1119 PC Schiphol-Rijk  
The Netherlands  
Telephone: [+31] (0)20-655 6776  
Fax: [+31] (0)20-655 6800

Eaton Hydraulics (Shanghai) Co. Ltd.  
388 Aidu Road, Waigaogiao FTZ  
Pudong New Area  
Shanghai 200137  
Peoples Republic of China  
Telephone: [+86] 21-5046 0758  
Fax: [+86] 21-5046 0767

Sumitomo Eaton Hydraulic Co.  
8 Temasek Blvd.  
42-01 Suntec Tower Three  
Singapore 03988  
Telephone: [+65] 832-7727  
Fax: [+65] 832-7733

Jining Eaton Hydraulic Co. Ltd.  
6 Ji Da Road  
Jining City  
Shandong Province 272131  
Peoples Republic of China  
Telephone: [+86] 537-2221288  
Fax: [+86] 537-2221557



**Quality System Certified**  
Products in this catalog are manufactured  
in an ISO-9001-certified site.

**Char-Lynn®**  
Hydraulic Motor

No. 7-125  
January, 1995



**Repair Information**

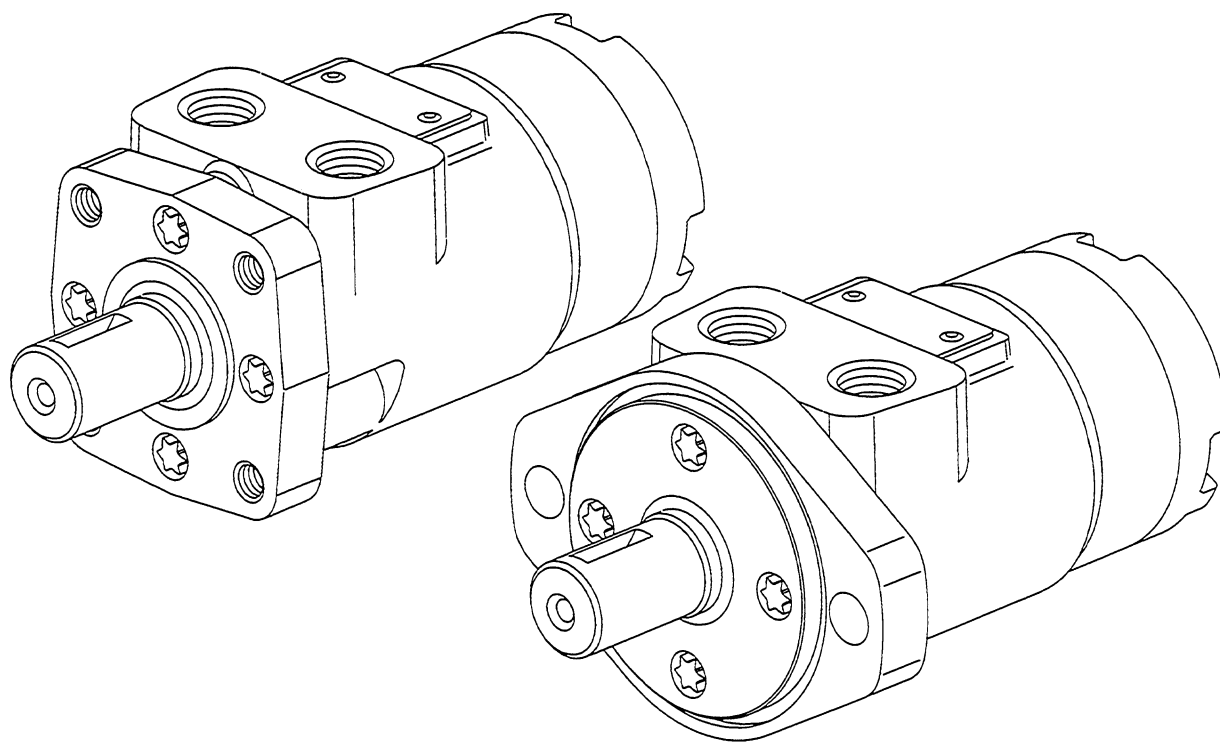

**A Series**  
**General Purpose Geroler® Motor**

**001 002 003**

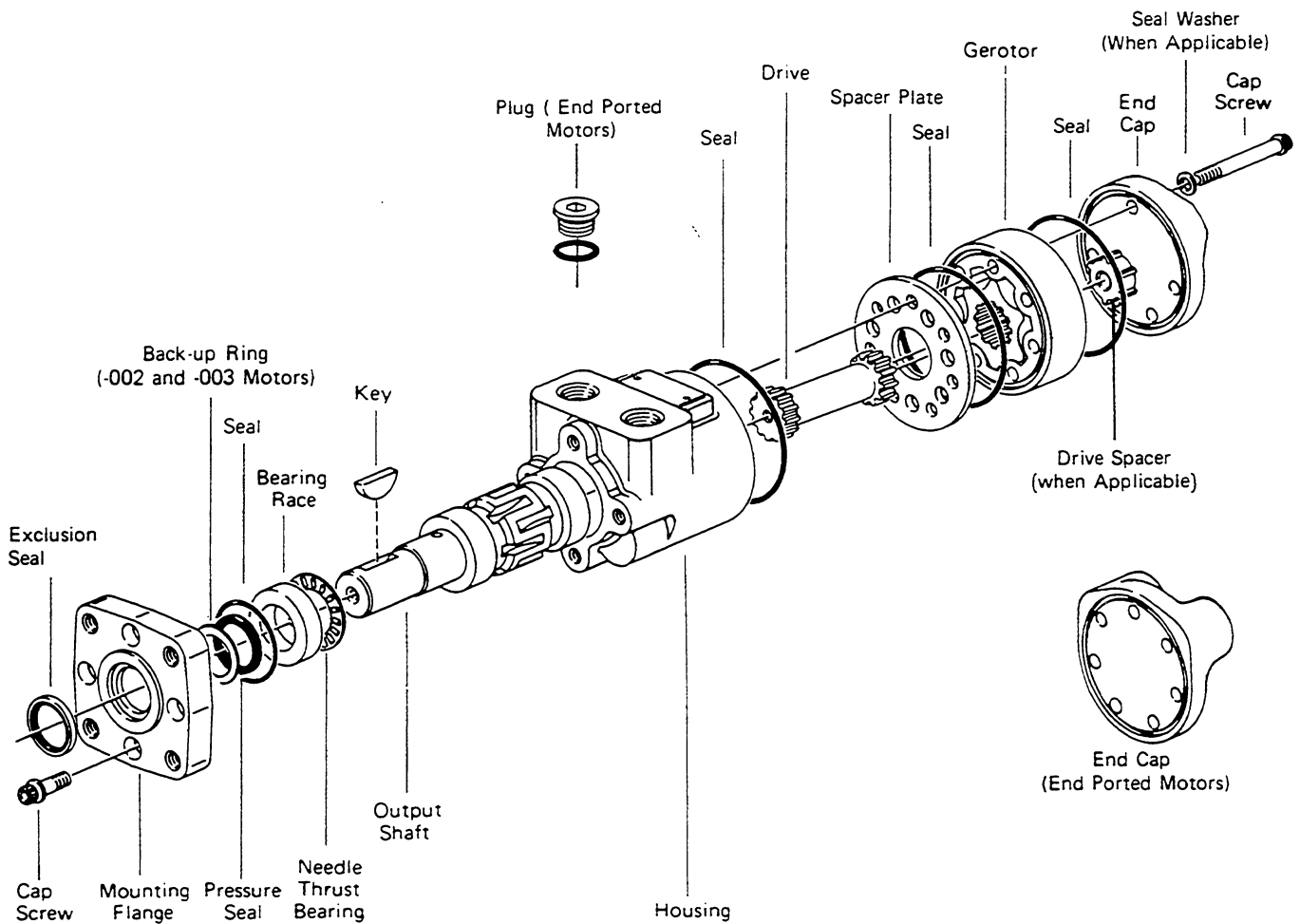

**Tools required for disassembly and reassembly.**

- Torque wrench (300 lb-in [34Nm] capacity)
- 12-16 in. [300-400mm] breaker bar
- \* 5/16 –12 point socket no. 5422 (Heavy Duty 500 lb-in [56Nm] Capacity)
- Small screwdriver (6-8x1/4 in. [150-200x6mm] flat blade), see page 5 for tooling information.
- \* Shaft pressure seal installation tool for 001 motor P/N 600470, for 002 and 003 motors P/N 600523
- \* Seal sleeve or bullet P/N 600304 (1 in. dia. shaft), P/N 600466 (7/8 in. dia. shaft)

\*Tools available—by special order—through our service department.



# Repair Information

## A Series Char-Lynn Motors Disassembly

Instructions in this manual are for standard A Series Motors (130-XXXX-001, 002 and 003).

Cleanliness is extremely important when repairing these motors. Work in a clean area. Before disconnecting lines, clean port area of motor. Remove key when used. Check shaft and key slot. Remove burrs, nicks and sharp edges. Before disassembly, drain oil from motor. Then plug ports and thoroughly clean exterior of motor.

Although not all drawings show the motor in a vise, we recommend that you keep the motor in a vise during disassembly. Follow the clamping procedures explained throughout the manual.

### Gerotor End

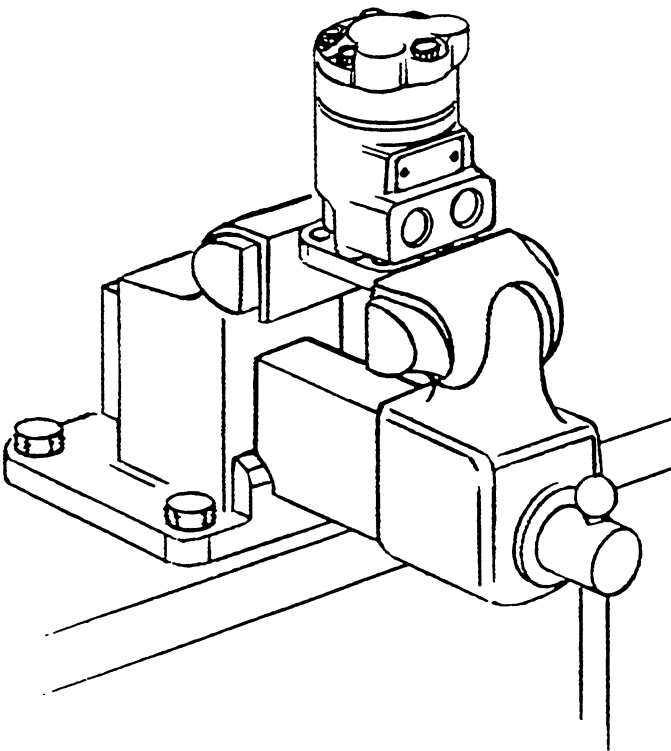

Figure 1

1 Place motor in vise and clamp across edge of flange with output shaft down. When clamping, use protective device on vise such as special soft jaws, pieces of hard rubber or board. See Figure 1.

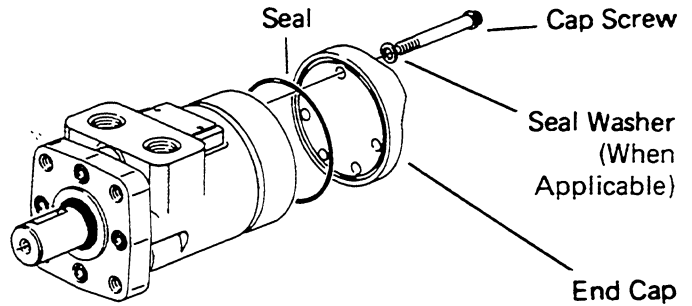

Figure 2

- 2 Remove cap screws and seal washers (when applicable). See Figure 2.
- 3 Remove end cap.
- 4 Remove seal from end cap.

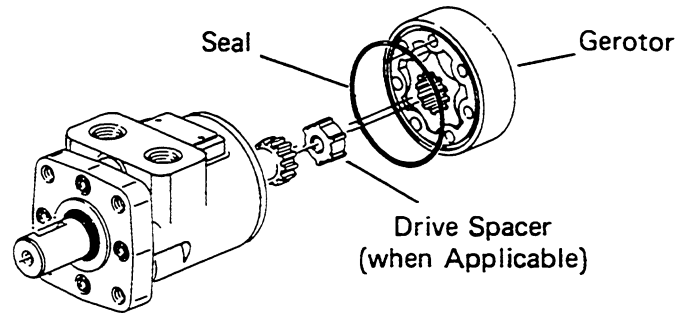

Figure 3

- 5 Remove gerotor.
- 6 Remove seal from gerotor (Figure 3).
- 7 Remove drive spacer if applicable.

3

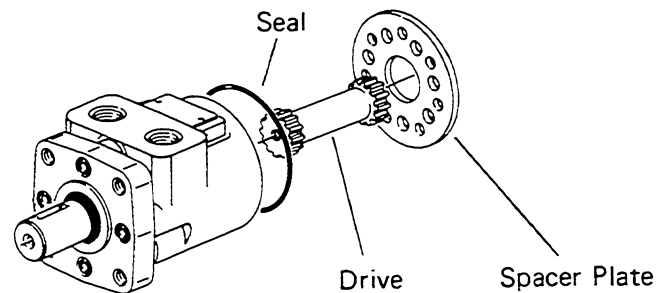

Figure 4

- 8 Remove drive. See Figure 4.
- 9 Remove spacer plate.
- 10 Remove seal from housing.
- 11 Remove output shaft from housing.
- 12 Remove needle thrust bearing from shaft or housing.

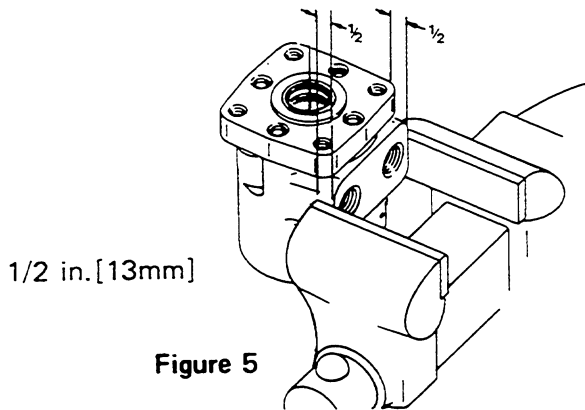

Figure 5

13 Reposition motor in vise. Clamp across ports as shown in Figure 5. Do not clamp on side of housing. Excessive clamping pressure on side of housing causes distortion.

14 Remove cap screws from mounting flange. These screws are assembled with Loctite to hold them in place.

The screws will require 300-400 lb-in [35-45 Nm] of torque to break loose and 100 lb-in [11 Nm] torque to remove. Do not use impact wrench on Loctited screws. This could result in rounded heads or broken sockets.

**Note:** If torque higher than given above is required to break screws loose, apply heat according to following instructions:

4

When heated, Loctite partially melts. This reduces torque required to remove screw. Use small flame propane torch to heat small area of housing where screw enters. See Figure 6. **Be careful not to overheat housing** and damage motor. Gradually apply torque to screw with **socket** wrench as heat is applied for 8 to 10 seconds. As soon as screw breaks loose, remove heat from housing. Continue turning screw until it is completely removed.

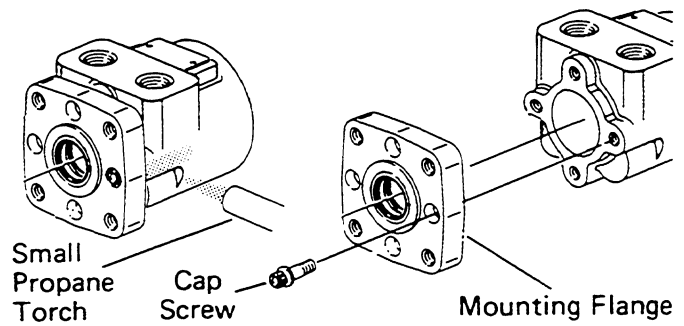

Figure 6

15 Remove motor from vise. Place motor on clean flat surface. Carefully remove flange from housing.

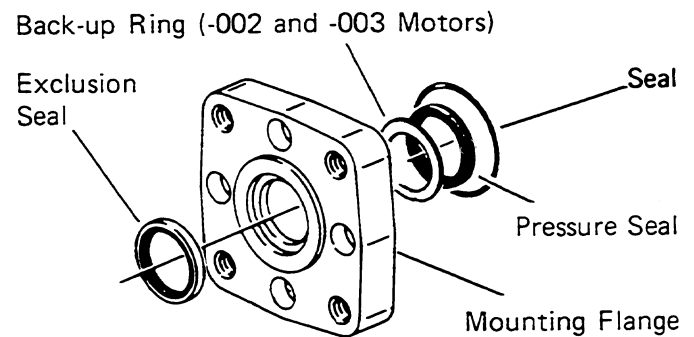

Figure 7

16 Exclusion seal, back-up ring, pressure seal and seal will come off with flange (Figure 7). Use seal removal tool, shown in Figures 8 and 9, to remove exclusion and pressure seals.

**Important:** Be careful not to scratch seal cavity O.D. This could create a leak path.

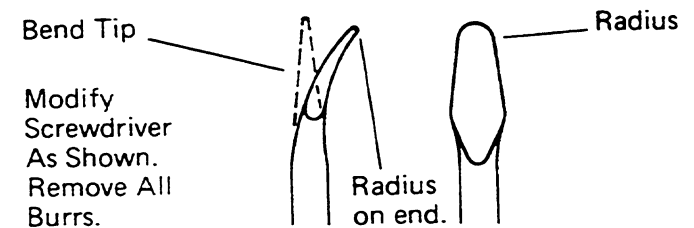
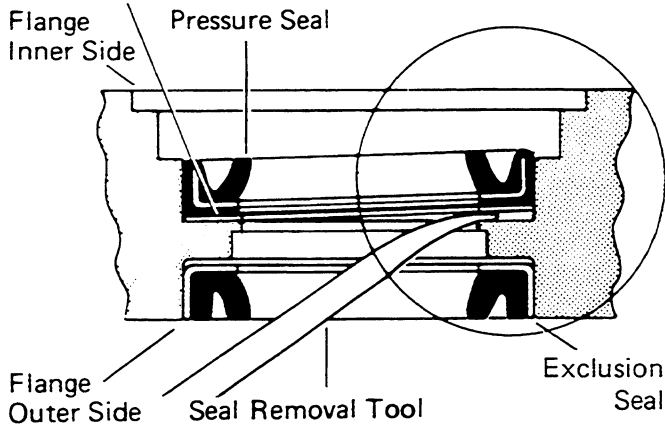

Figure 8

Back-up Ring (-002 and -003 Motors)



Work from outer side for both (either) seals.

Figure 9

## Reassembly

### Shaft End

Check all mating surfaces. Replace any parts with scratches or burrs that could cause leakage or damage. Clean all metal parts in clean solvent. Blow dry with air. Do not wipe parts with cloth or paper towel because lint or other matter could get into the hydraulic system and cause damage.

Check around key slot and chamfered area of shaft for burrs, nicks or sharp edges that could damage seals during reassembly. Remove nicks or burrs with a hard smooth stone (such as an Arkansas stone). Do not file or grind motor parts.

**Note:** Lubricate all seals with petroleum jelly. Use new seals when reassembling motor. Refer to parts list 6-130 for proper seal kit numbers.

**Important:** Do not stretch seals before installing them.

Cleanliness is extremely important in the successful application of Loctite. Before Loctite can be applied, the parts should be cleaned as follows:

**Note:** Fully cured Loctite resists most solvents, oils, gasoline and kerosene and is not affected by cleaning operations. It is not necessary to remove cured Loctite that is securely bonded in tapped holes; however, any loose particles of cured Loctite should be removed.

**a.** Wash the housing with solvent to remove oil, grease and debris. Pay particular attention to four tapped holes on flange end.

**b.** Blow dry with compressed air. Clean and dry tapped holes.

**c.** Wire brush screw threads to remove cured Loctite and other debris. Discard any screws that have damaged threads or rounded heads.

**d.** Wash screws with non-petroleum base solvent. Blow dry with compressed air.

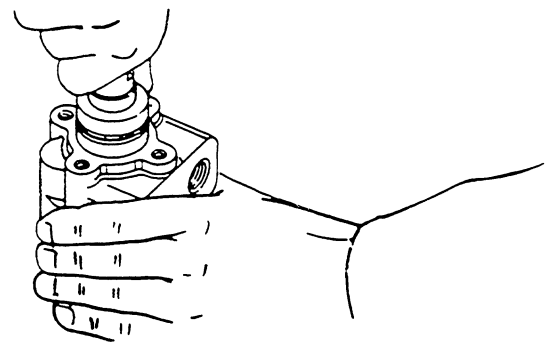
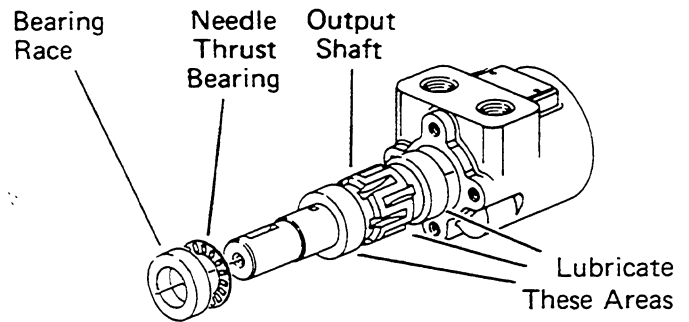
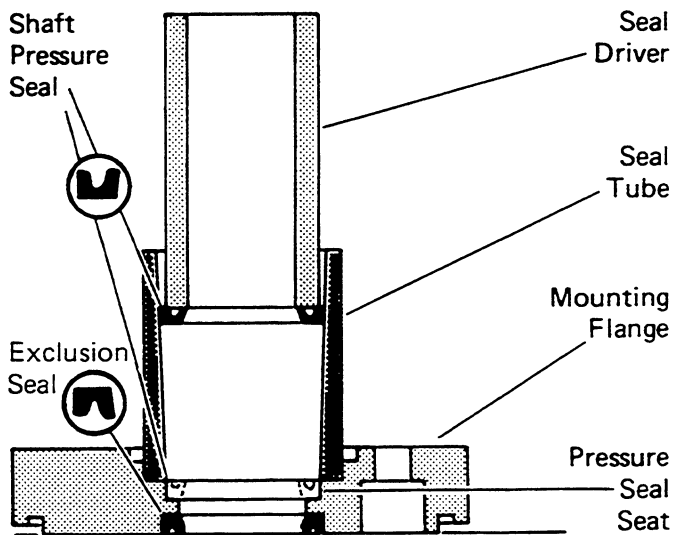

Figure 10

**17** Lubricate output shaft with hydraulic oil, then install shaft in housing. See Figure 10.

**Important: Do not permit oil to get into the four tapped holes.**

**18** Install needle thrust bearing, then bearing race on shaft. Pull shaft partially out of housing. Push all three parts in housing together. See Figure 10. The bearing race must rotate freely when in position.



Seal Installation Tool  
 No. 600470 —001 Motors  
 No. 600523 —002 and —003 Motors

Figure 11

**19** Install exclusion seal in flange. See Figure 11. Carefully press exclusion seal into place.

**20** Visually check seal seat in mounting flange for scratches or other marks that might damage the pressure seal. Check for cracks in flange that could cause leakage.

**21** Lubricate I.D. of seal tube and O.D. of shaft pressure seal with light film of clean petroleum jelly. Align small I.D. end of seal tube with seal seat in mounting flange. Install back-up ring and pressure seal in tube with lips of seal face up. See Figure 11. Insert seal driver in tube and firmly push seal seat with a rotating action.

**Important: After installing seal in flange, examine seal condition. If damaged or improperly installed, you must replace it before continuing with reassembly.**

**22** Install 1<sup>15</sup>/<sub>16</sub> in. [49 mm] I.D. seal in flange.

**23** It is recommended to apply a light coat of Loctite Primer NF in tapped holes of housing. Allow primer to air dry for at least 1 minute. Do not force dry with air jet; the primer will blow away.

Use of primer is optional. With primer, Loctite curing time is approximately 15 minutes. Without primer, curing time is approximately 6 hours.

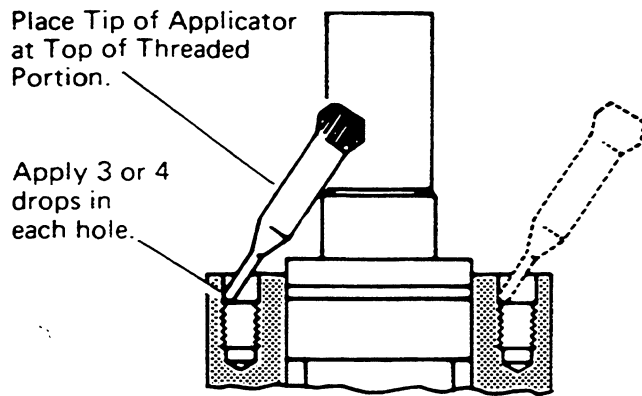

Figure 12

**24** Apply 3 or 4 drops of Loctite sealant at top of thread for each of four holes in housing. See Figure 12. Do not allow parts with Loctite applied to come in contact with any metal parts other than those for assembly. Wipe off excess Loctite from housing face, using a non-petroleum base solvent.

Do not apply Loctite to threads more than 15 minutes before installing screws. If housing stands for more than 15 minutes, repeat application. No additional cleaning or removal of previously applied Loctite is necessary.

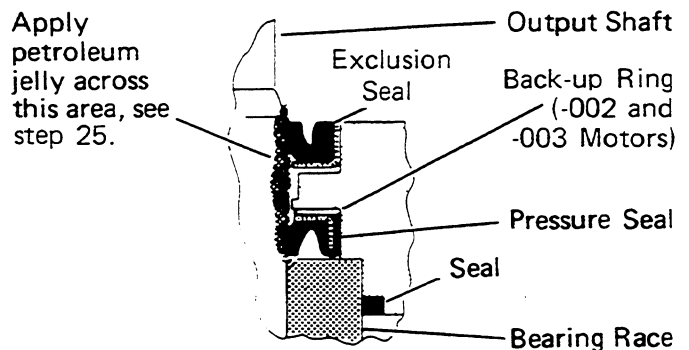

Figure 13

**25** Before installing flange and seal assembly over shaft, place protective sleeve or bullet over shaft. Then lubricate space between exclusion seal and pressure seal, as well as lips of both seals. See Figure 13.

Install flange. Rotate flange slowly while pushing down over shaft. Be careful not to invert or damage seals.

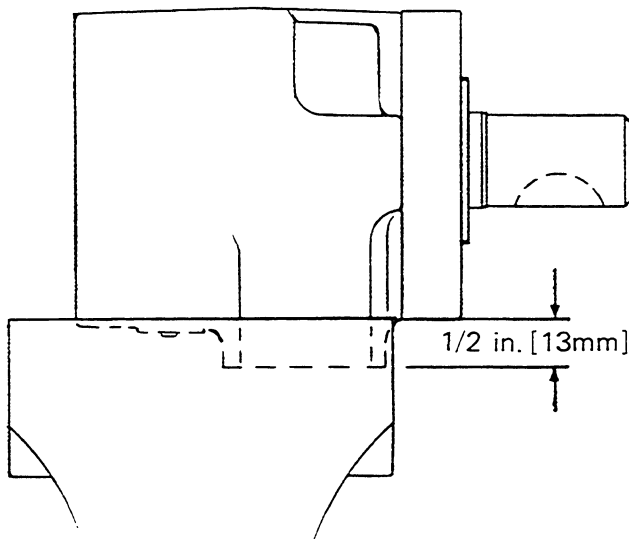

Figure 14

**26** After removing bullet, clamp motor in vise as shown in Figure 14. Make sure shaft cannot fall out. Install **dry** screws and alternately torque them immediately to 250 lb-in [28 Nm]. If you use primer, allow to cure for **10 to 15 minutes**. Without primer, allow 6 hours curing time before subjecting motor to high torque reversals. On all other applications, you can run motor immediately.

If you use new screws, make sure they are the correct length:  $\frac{7}{8}$  in. [22 mm] under head length. See parts list for correct part number.

### Gerotor End

**27** Reposition motor with gerotor end up, then clamp across ports. Do not clamp on side of housing.

**Important:** To aid installation of seals, apply light coat of clean petroleum jelly to seals. Do not stretch seals before installing them in groove.

**28** Pour approximately 35 cc of clean hydraulic oil in output shaft cavity.

**29** Install  $2\frac{7}{8}$  in. [73 mm] I.D. seal in housing seal groove. Avoid twisting seal.

### Timing Procedure

a. Install drive. Use felt tip marker to mark one drive tooth. Align this tooth with timing dot on shaft.

**Note:** If drive is not symmetrical, install larger splined end into shaft.

b. Install spacer plate.

c. Install  $2\frac{7}{8}$  in. [73 mm] I.D. seal in gerotor seal groove. Carefully place gerotor on spacer plate, seal side toward spacer plate.

**Standard Rotation** Align any star point with tooth marked on drive. See Figure 15.

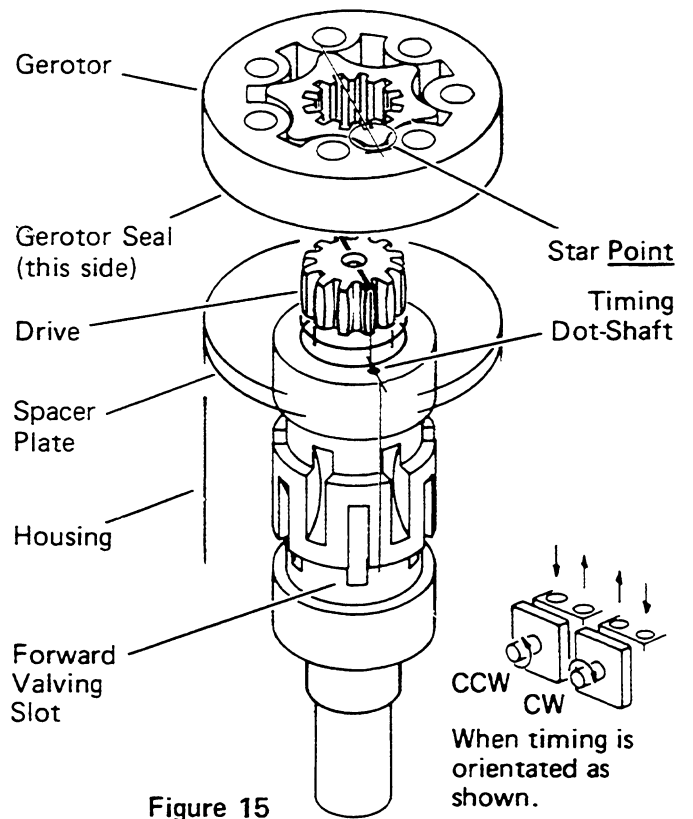

Figure 15

**Reverse Rotation** Align any star valley with marked tooth. See Figure 16.

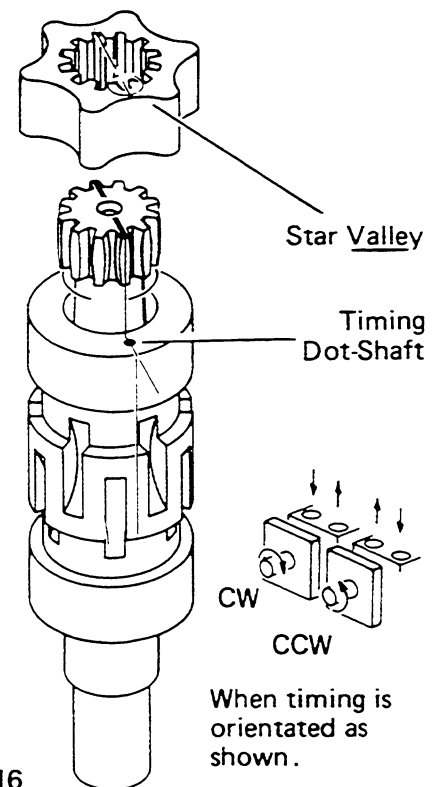

Figure 16

Reassembly Continued from Page 7

**30** Rotate gerotor to line up with bolt holes. Be careful not to disengage star from drive or disturb gerotor seal.

**31** Install drive spacer if applicable.

**32** Install 2 7/8 in. [73 mm] seal in end cap. Carefully place end cap on gerotor.

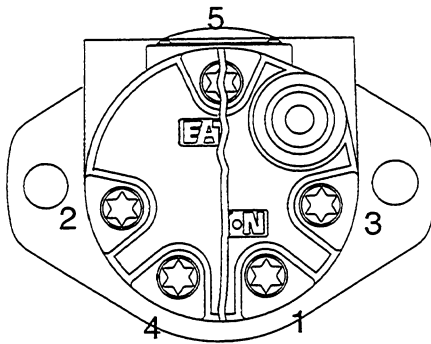

Bolt Torquing Sequence

**Figure 17**

**33** Install cap screws and seal washers (if applicable) in end cap. Pretighten screws to 40 lb-in [7,4 Nm]. Make sure seal are properly seated. Then torque screws 275-300 lb-in [30-40 Nm] in sequence, as shown in figure 17.

## How to Order Replacement Parts

### Each Order Must Include the Following:

1. Product Number
2. Date Code
3. Part Name
4. Part Number
5. Quantity of Parts

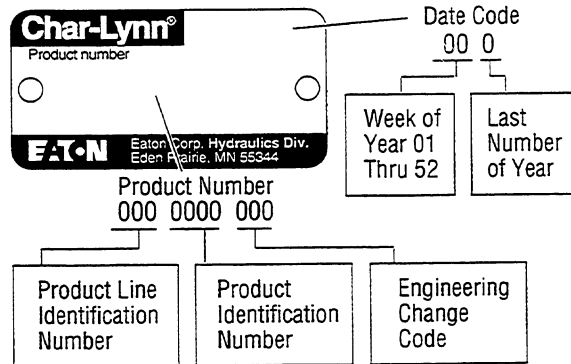

Eaton Corporation  
**Hydraulics Division**  
15151 Hwy. 5  
Eden Prairie, MN 55344  
Telephone 612/937-9800  
Fax 612/937-7130

Eaton Ltd.  
**Hydraulics Division**  
Glenrothes, Fife  
Scotland, KY7 4NW  
Telephone 44/592-771-771  
Fax 44/592-773-184



## Repair Information

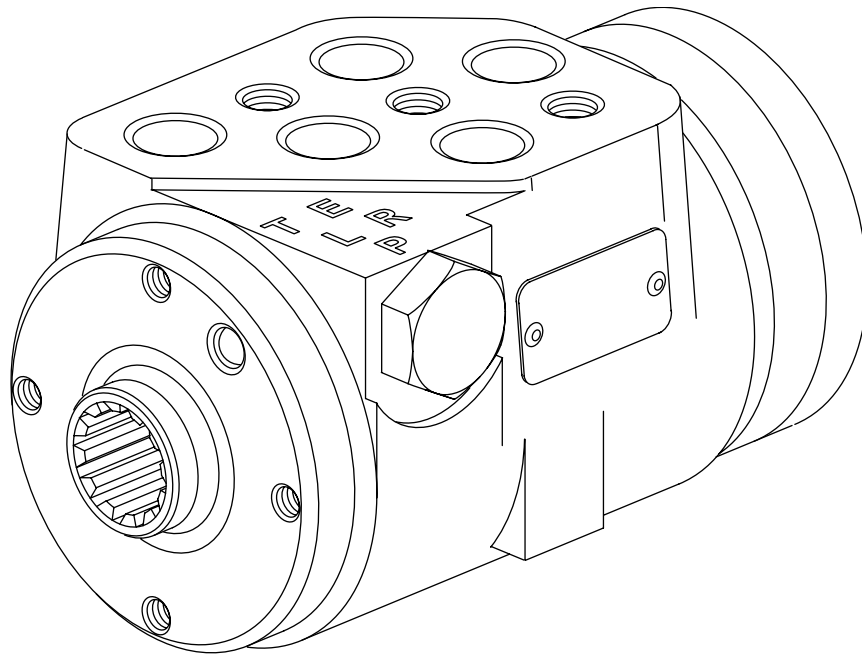

**2 Series**  
**Steering Control Unit**

**001**

## 2 Series Steering Control Units

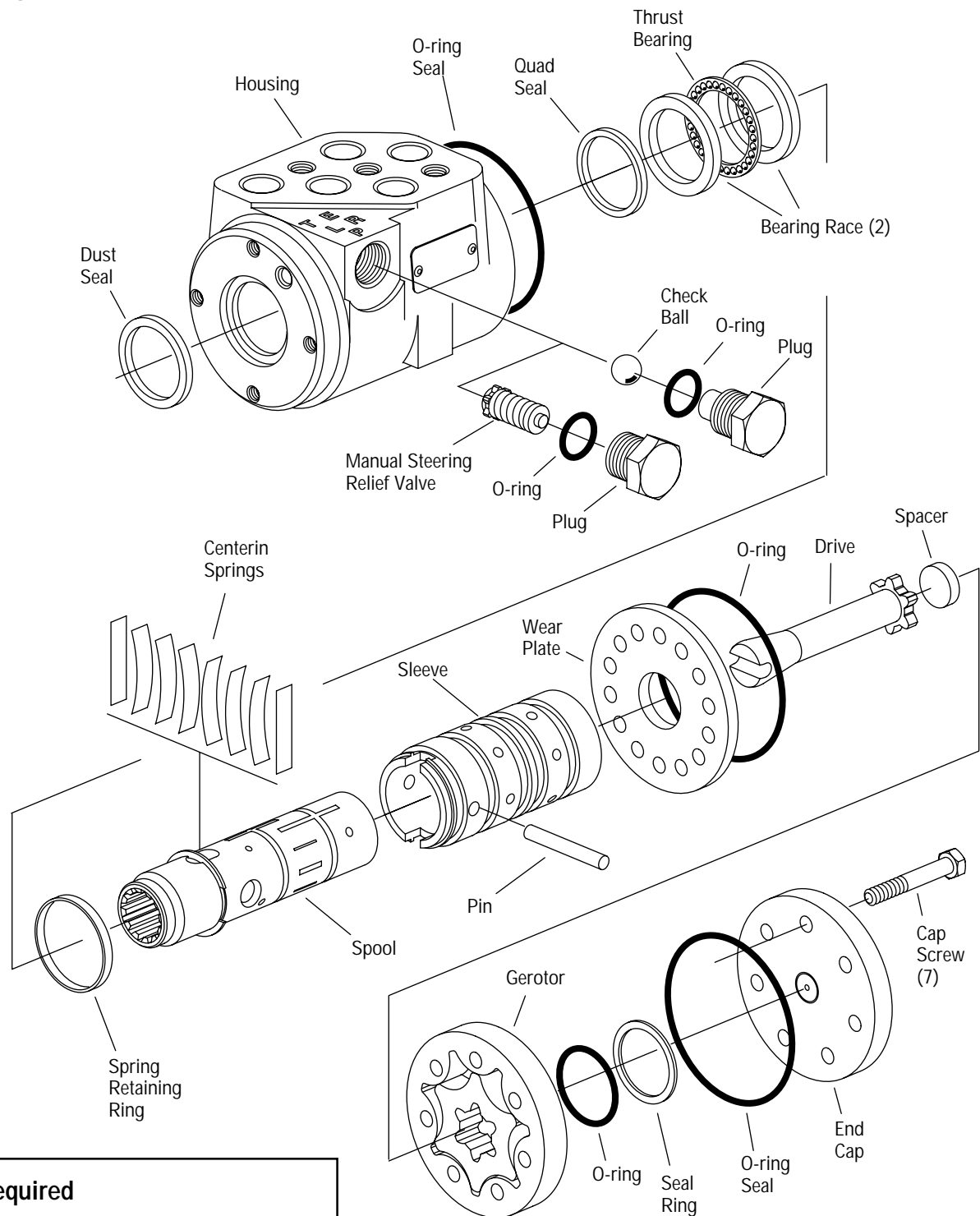

### Tools Required

- 10 mm Socket
- 7/8 in. Socket
- Torque Wrench (18 Nm [160 lb-in] Capacity)
- Small Blade Screwdriver



## 2 Series Steering Control Units

### Disassembly

Cleanliness is extremely important when repairing hydraulic Steering Control Units (SCU). Work in a clean area. Before disconnecting the hydraulic lines, clean the port area of the SCU. Before disassembly, drain the oil, then plug the ports and thoroughly clean the exterior of the SCU. During repairs, always protect machined surfaces.

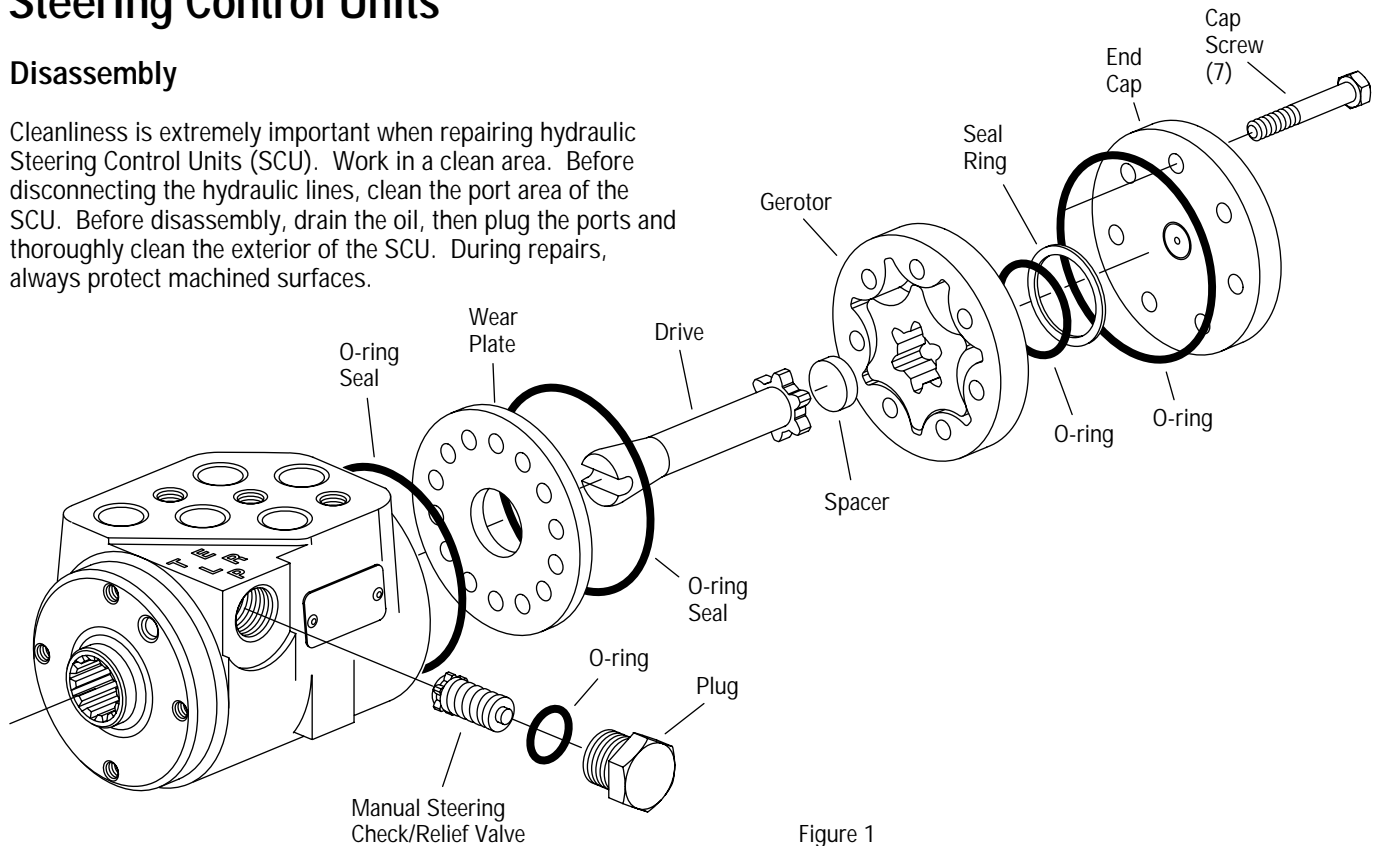

Figure 1

1 Remove the seven cap screws and disassemble the SCU as shown in Figure 1.

2 Remove the plug and manual steering check as shown in Figure 1.

**Note:** The manual steering check may be a check ball or a check/relief valve.

3 Slide the spool and sleeve from the housing (see Figure 2).

4 Remove the thrust bearing and bearing races.

5 Remove the quad seal.

6 Using a small blade screwdriver, carefully pry the dust seal from the housing.

**Important:** Do not damage the dust seal seat.

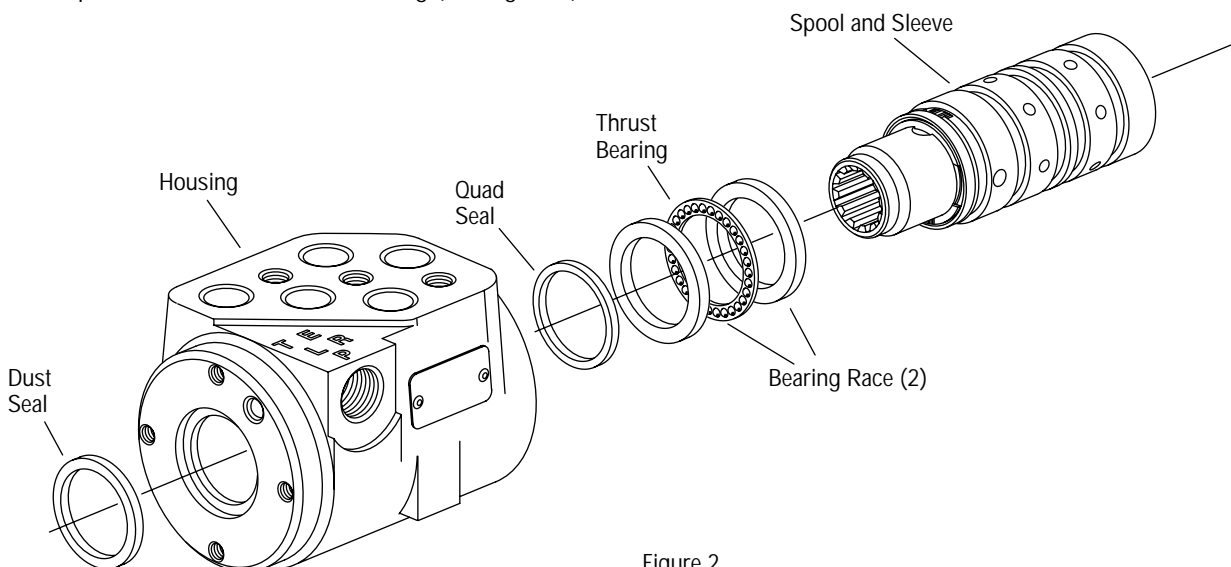

Figure 2

## 2 Series Steering Control Units

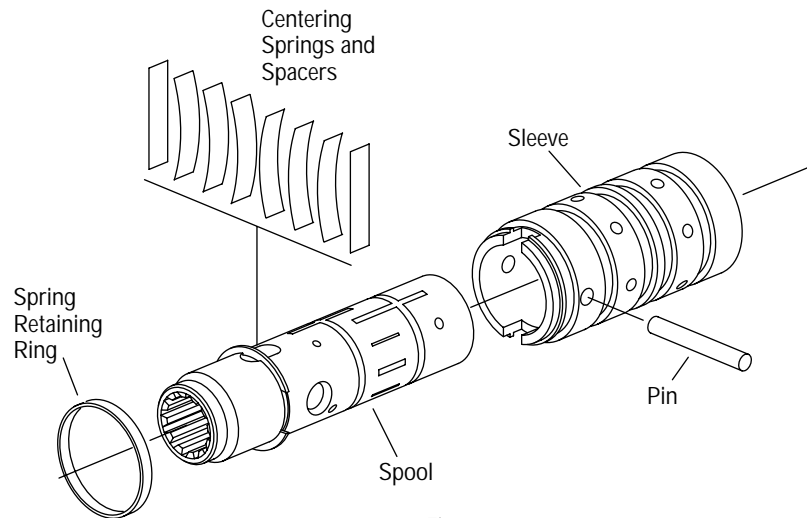

Figure 3

7 Remove the pin that holds the spool and sleeve together (see Figure 3).

8 Carefully slide the spool out of the sleeve. The springs and retaining ring will stay with the spool as it's removed.

9 Remove the retaining ring and springs.

**Caution:** The centering springs are under tension. Remove the retaining ring carefully.

### Reassembly

Check all mating surfaces. Replace any parts with scratches or burrs that could cause leakage. Wash all metal parts in clean solvent. Blow them dry with pressurized air. **Do not** wipe parts dry with paper towels or cloth as lint in a hydraulic system will cause damage.

**Note:** Always use new seals when reassembling hydraulic steering control units. Refer to parts list 6-323 for seal kit part numbers, replacement parts, and ordering information.

**Important:** During reassembly lubricate the new seals with a petroleum jelly such as Vaseline®. Also lubricate machined surfaces and bearings with clean hydraulic fluid.

10 Install the quad seal:

- Put one of the bearing races and sleeve into the housing.
- Together, the housing and bearing race create a groove into which the quad seal will be installed.
- Hold the bearing race tightly against the input end of the housing by pushing on the gerotor end of the sleeve.
- Fit the quad seal into its seat through the input end of the housing. Be sure the seal is not twisted.
- Remove the sleeve and bearing race.

## 2 Series Steering Control Units

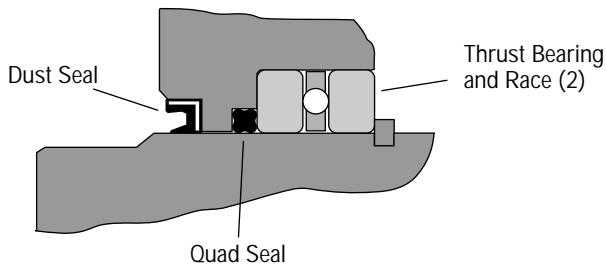

Figure 4

- 11 Lubricate and install the dust seal (see Figure 4 for correct seal orientation).
  - 12 Install the centering springs in the spool. It is best to install the two flat pieces first. Next, install the curved pieces, three at a time.
  - 13 Fit the retaining ring over the centering springs.
  - 14 Apply a light coating of clean hydraulic fluid to the spool and slide it into the sleeve. Be sure the centering springs fit into the notches in the sleeve.
  - 15 Install the pin (see Figure 3).
  - 16 Apply a light coating of petroleum jelly to the inner edge of the dust and quad seals.
  - 17 Put the thrust bearing and races into the housing. The thrust bearing goes between the two races (see Figure 2).
  - 18 Apply a light coating of clean hydraulic fluid to the spool and sleeve assembly and slide it into the housing.
- Important: Do not damage the dust or quad seals.**
- 19 Clamp the housing in a vise as shown in Figure 5. Use just enough clamping force to hold the housing securely.

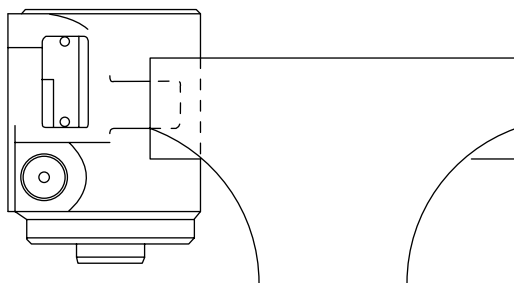

Figure 5

- 20 Lubricate and install a new o-ring seal in the groove in the housing.
  - 21 Install the wear plate and align the holes in the wear plate with threaded holes in the housing.
- Note: The holes in the wear plate are symmetrical.**
- 22 Install the drive, be sure the slot in the drive engages the pin.
  - 23 Lubricate and install a new o-ring seal in the groove in the wear plate.
  - 24 Install the gerotor and align the screw holes.
  - 25 Lubricate and install a new o-ring seal in the groove in the gerotor ring.
  - 26 Lubricate and install a new o-ring and seal ring in the groove in the gerotor star.
  - 27 Install the spacer.
  - 28 Install end cap and seven cap screws. Tighten cap screws, in a crisscross pattern, to 16 -18 Nm [140 -160 lb-in].
  - 29 Remove the SCU from the vise.
  - 30 Install the relief valve/check or check ball and plug. Use a new o-ring and tighten the plug to 17 Nm [150 lb-in].

## 2 Series Steering Control Units

### Product Numbers 2 Series (Standard — 69 Bar [1000 PSI])

System	Ports	Relief Valve Setting Bar [PSI]	Displacement cm <sup>3</sup> /r [in <sup>3</sup> /r] and Product Number						
			31 [1.9]	39 [2.4]	51 [3.1]	63 [3.8]	74 [4.5]	100 [6.1]	
Open Center Non-Load Reaction	9/16 Inch Plug-O (4)	None	291-1001-001	291-1002-001	291-1003-001	291-1004-001	291-1005-001	291-1006-001	
		40 [ 580]	291-1001-041	291-1002-041	291-1003-041	291-1004-041	291-1005-041	291-1006-041	
		50 [ 725]	291-1001-051	291-1002-051	291-1003-051	291-1004-051	291-1005-051	291-1006-051	
		63 [ 914]	291-1001-061	291-1002-061	291-1003-061	291-1004-061	291-1005-061	291-1006-061	
		70 [1015]	291-1001-071	291-1002-071	291-1003-071	291-1004-071	291-1005-071	291-1006-071	
	9/16 -18 Inch SAE (4)	None	291-1007-001	291-1008-001	291-1009-001	291-1010-001	291-1011-001	291-1012-001	
		40 [ 580]	291-1007-041	291-1008-041	291-1009-041	291-1010-041	291-1011-041	291-1012-041	
		50 [ 725]	291-1007-051	291-1008-051	291-1009-051	291-1010-051	291-1011-051	291-1012-051	
		63 [ 914]	291-1007-061	291-1008-061	291-1009-061	291-1010-061	291-1011-061	291-1012-061	
		70 [1015]	291-1007-071	291-1008-071	291-1009-071	291-1010-071	291-1011-071	291-1012-071	
	Power Beyond Non-Load Reaction	9/16 Inch Plug-O (5)	None	291-5001-001	291-5002-001	291-5003-001	291-5004-001	291-5005-001	291-5006-001
			40 [ 580]	291-5001-041	291-5002-041	291-5003-041	291-5004-041	291-5005-041	291-5006-041
			50 [ 725]	291-5001-051	291-5002-051	291-5003-051	291-5004-051	291-5005-051	291-5006-051
			63 [ 914]	291-5001-061	291-5002-061	291-5003-061	291-5004-061	291-5005-061	291-5006-061
70 [1015]			291-5001-071	291-5002-071	291-5003-071	291-5004-071	291-5005-071	291-5006-071	
9/16 -18 Inch SAE (5)		None	291-5007-001	291-5008-001	291-5009-001	291-5010-001	291-5011-001	291-5012-001	
		40 [ 580]	291-5007-041	291-5008-041	291-5009-041	291-5010-041	291-5011-041	291-5012-041	
		50 [ 725]	291-5007-051	291-5008-051	291-5009-051	291-5010-051	291-5011-051	291-5012-051	
		63 [ 914]	291-5007-061	291-5008-061	291-5009-061	291-5010-061	291-5011-061	291-5012-061	
		70 [1015]	291-5007-071	291-5008-071	291-5009-071	291-5010-071	291-5011-071	291-5012-071	
Dynamic Signal Load Sensing	9/16 Inch Plug-O (5)	None	293-4001-001	293-4002-001	293-4003-001	293-4004-001	293-4005-001	293-4006-001	
	9/16 -18 Inch SAE (5)	None	293-4007-001	293-4008-001	293-4009-001	293-4010-001	293-4011-001	293-4012-001	

### Product Numbers 2 Series (High Pressure — 103 Bar [1500 PSI])

Open Center Non-Load Reaction	9/16 Inch Plug-O (4)	None	291-1001-121	291-1002-121	291-1003-121	291-1004-121	291-1005-121	291-1006-121		
		80 [1160]	291-1001-081	291-1002-081	291-1003-081	291-1004-081	291-1005-081	291-1006-081		
		90 [1305]	291-1001-091	291-1002-091	291-1003-091	291-1004-091	291-1005-091	291-1006-091		
		100 [1450]	291-1001-101	291-1002-101	291-1003-101	291-1004-101	291-1005-101	291-1006-101		
	9/16 -18 Inch SAE (4)	None	291-1007-121	291-1008-121	291-1009-121	291-1010-121	291-1011-121	291-1012-121		
		80 [1160]	291-1007-081	291-1008-081	291-1009-081	291-1010-081	291-1011-081	291-1012-081		
		90 [1305]	291-1007-091	291-1008-091	291-1009-091	291-1010-091	291-1011-091	291-1012-091		
		100 [1450]	291-1007-101	291-1008-101	291-1009-101	291-1010-101	291-1011-101	291-1012-101		
		Power Beyond Non-Load Reaction	9/16 Inch Plug-O (5)	None	291-5001-121	291-5002-121	291-5003-121	291-5004-121	291-5005-121	291-5006-121
				80 [1160]	291-5001-081	291-5002-081	291-5003-081	291-5004-081	291-5005-081	291-5006-081
90 [1305]	291-5001-091	291-5002-091		291-5003-091	291-5004-091	291-5005-091	291-5006-091			
100 [1450]	291-5001-101	291-5002-101		291-5003-101	291-5004-101	291-5005-101	291-5006-101			
9/16 -18 Inch SAE (5)	None	291-5007-121	291-5008-121	291-5009-121	291-5010-121	291-5011-121	291-5012-121			
	80 [1160]	291-5007-081	291-5008-081	291-5009-081	291-5010-081	291-5011-081	291-5012-081			
	90 [1305]	291-5007-091	291-5008-091	291-5009-091	291-5010-091	291-5011-091	291-5012-091			
	100 [1450]	291-5007-101	291-5008-101	291-5009-101	291-5010-101	291-5011-101	291-5012-101			
Dynamic Signal Load Sensing	9/16 Inch Plug-O (5)	None	293-4001-121	293-4002-121	293-4003-121	293-4004-121	293-4005-121	293-4006-121		
	9/16 -18 Inch SAE (5)	None	293-4007-121	293-4008-121	293-4009-121	293-4010-121	293-4011-121	293-4012-121		

---

## 2 Series Steering Control Units

# 2 Series Steering Control Units

## How to Order Replacement Parts

### Each Order Must Include the Following:

1. Product Number
2. Date Code
3. Part Name
4. Part Number
5. Quantity of Parts

For More Detailed Information Contact Eaton Corp. Hydraulics Division 15151 Highway 5 Eden Prairie, MN 55344.

- Specifications and performance data, Catalog No. 11-872
- Replacement part numbers and kit information — Parts Information No. 7-310.

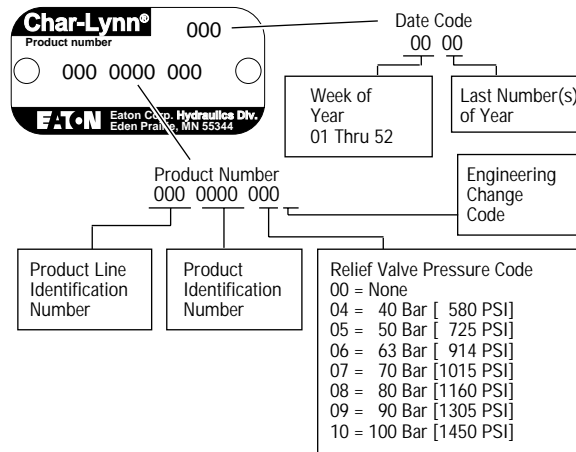

Eaton Corporation  
**Hydraulics Division**  
 15151 Hwy. 5  
 Eden Prairie, MN 55344  
 Telephone 612/937-9800  
 Fax 612/937-7130

Eaton Ltd.  
**Hydraulics Division**  
 Glenrothes, Fife  
 Scotland, KY7 4NW  
 Telephone 01-592-771-771  
 Fax 01-592-773-184

Eaton GmbH  
**Hydraulics Products**  
 Am Schimmersfeld 7  
 40880 Ratingen, Germany  
 Telephone 02102-406-830  
 Fax 02102-406-800

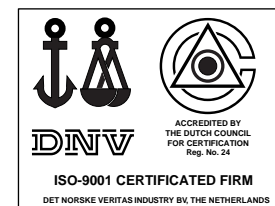

**Quality System Certified**  
 Products in this catalog are manufactured  
 in an ISO-9001-certified site.

**Eaton  
Hydraulics  
Division**

# Repair Information

---

## Model 30920 - 30930 Directional Control Valve

---

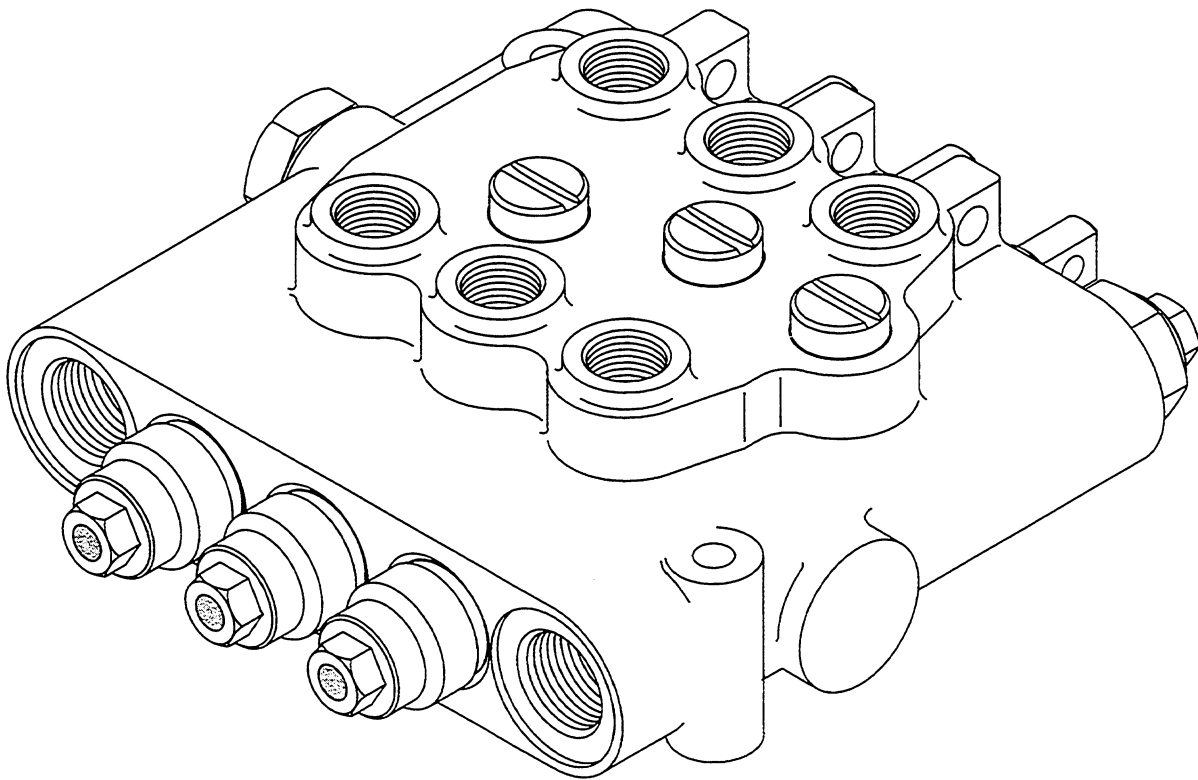

**EATON**

# Parts Drawing

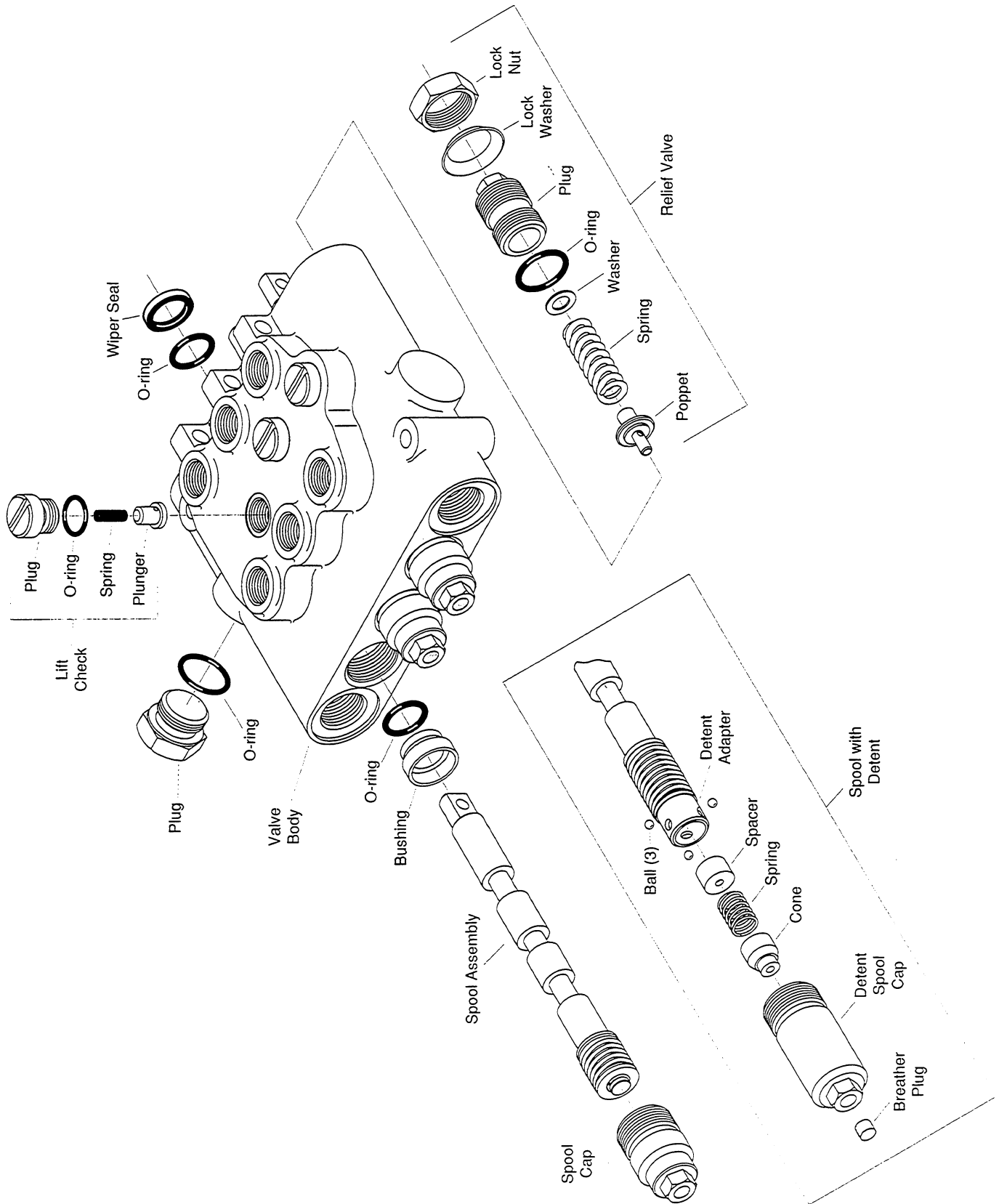



## Disassembly

Refer to the Parts Drawing as you perform the repairs.

1. Plug all ports and clean the outside of the valve thoroughly.
2. Mark the spools and their specific bores. The spools are matched to the bores and must not be switched.
3. Remove the spool caps and slide the spool assemblies from their bores.

If spools are detented, take care not to lose the balls, spacer, detent spring, or cone.

4. Remove the o-rings and bushings from the spools.
5. Remove the wiper seals and o-rings from the valve body.
6. Disassemble the spool assemblies only if the retaining ring, spacer, spool spring, or washer need to be replaced see figure 1.

**Note:** Do not disassemble spool assemblies with detents.

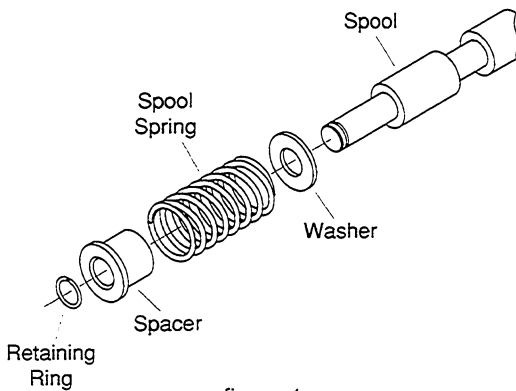

figure 1

7. Remove the lift check plugs, springs, and lift check plungers.
8. Remove the plug from the BYD port. This may be a solid plug, pressure beyond plug, or closed center plug.
9. Remove the relief valve lock nut, lock washer, plug, and o-ring .
10. Remove the washer, relief valve spring, and poppet.
11. Remove all o-rings and back-up rings from the plugs.

## Inspection

1. Inspect the spools for wear. If wear is excessive, the valve becomes non-serviceable.
2. Inspect all of the springs and replace as necessary. Replace spool springs as shown in figure 1.

**Note:** The spool springs on detented spools are not serviceable.

3. Inspect the relief valve parts for wear and replace as necessary.
4. Inspect the lift check plungers and their seats in the valve body.

## Reassembly

1. Wash all metal parts in clean solvent and blow them dry with compressed air. Do not wipe parts dry with paper towels or cloth. Lint in a hydraulic system will cause damage.

**Note:** Replace all o-rings, back-up rings and wiper seals as new.

2. Install new o-rings and wiper seals in the valve body.
3. Slide the bushings and new o-rings over the spools.
4. Liberally lubricate the spools with clean hydraulic fluid and install them in their proper bores.
5. Install the spool caps and tighten them to 20 - 25 lb-ft [27 - 34 Nm].

6. If spools are detented, install the spool caps as follows:

Remove the brass breather plug from the spool cap using a 3/16 inch drift punch.

Insert the punch through the hole in the spool cap.

Put the spacer, detent spring, cone, and balls into the detent adapter.

Hold the parts in place with the drift punch, while threading the spool cap into the valve body.

Tighten the cap to 20 - 25 lb-ft [27 - 34 Nm].

Install the breather plug.

7. Install the lift check plungers, springs, and lift check plugs. Use new o-rings and tighten the plugs to 20 - 25 lb-ft [27 - 34 Nm].
8. Install a new o-ring on the relief valve plug .
9. Insert the washer and relief valve spring into the plug .
10. Place the poppet on the spring and carefully install the relief valve into the valve body.
11. Install the lock washer and nut .
12. Adjust the relief valve setting and tighten the lock nut to 21 - 24 lb-ft [28 - 33 Nm].

---

Eaton Corporation **Hydraulics Division**, 15151 Highway 5, Eden Prairie, MN 55344 Telephone (612) 937-9800

Eaton G.m.b.H. **Hydraulics Division** ☒ 100 410 • D-5620 Velbert 1 West Germany ☎ 49-2051-2070



Printed in U.S.A.

FORM NO. 7- 503  
Issued June 1989



## Repair Information

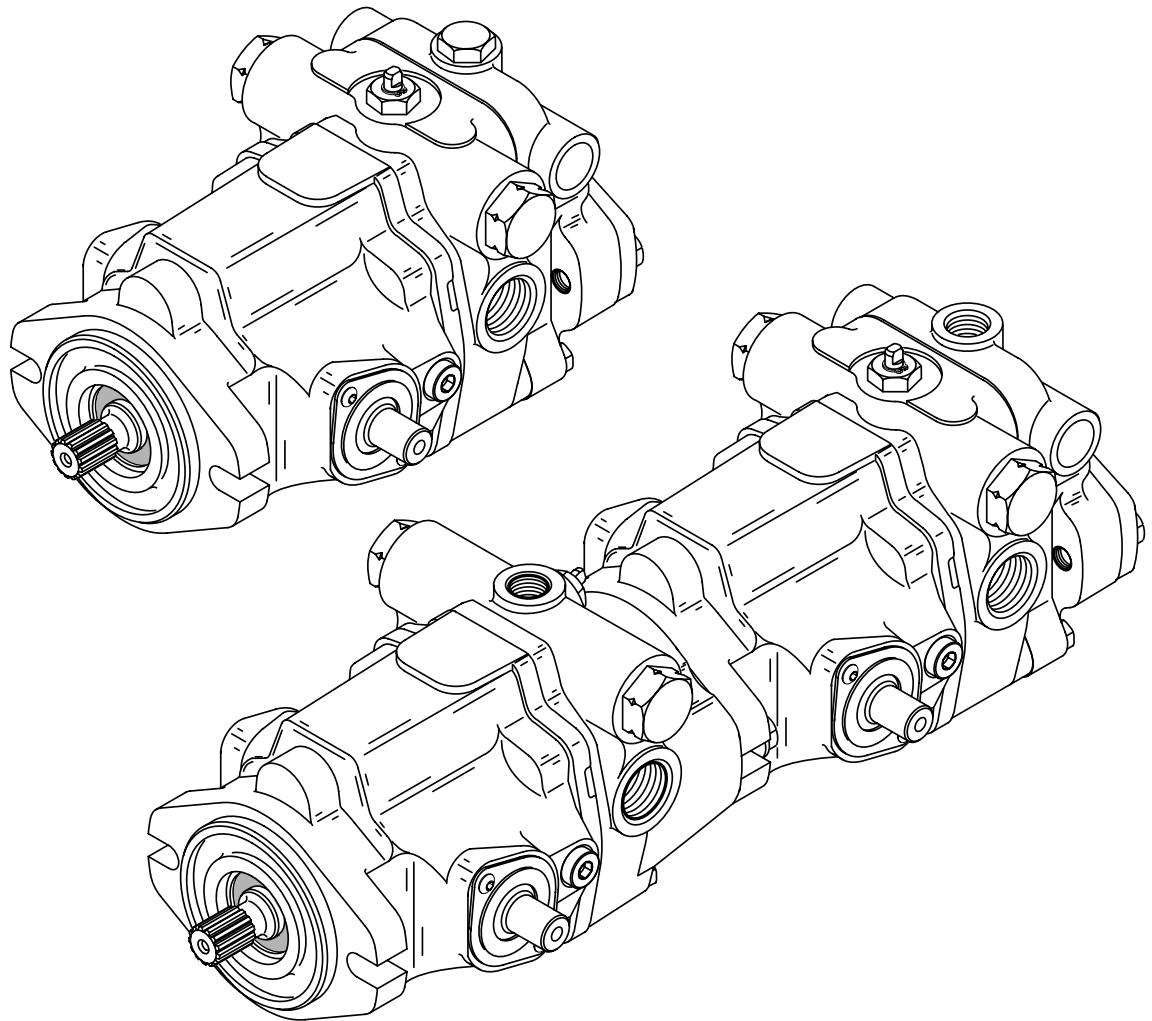

**Model 70142 / 70144, 20.3 cm<sup>3</sup>/r [1.24 in<sup>3</sup>/r] Displacement  
and 70145, 23.6 cm<sup>3</sup>/r [1.44 in<sup>3</sup>/r] Displacement  
Variable Displacement Piston Pump**

design code **01 02**

with **Valve Plate**

# Introduction

## Table of Contents

Introduction .....	2
Identification .....	3
Required Tools .....	3
Exploded View Drawing .....	4 & 5
Parts List .....	6 & 7
Disassembly and Inspection .....	8
Reassembly .....	9
Appendix A: .....	10
Appendix B: .....	11
Fault-Logic Trouble Shooting .....	12 - 16
Start-up Procedure .....	17

## Introduction

This manual provides service information for the Eaton Models 70142 / 70144 and 70145 Variable Displacement Piston Pumps. Step by step instructions for the complete disassembly, inspection, and reassembly of the pump are given. The following recommendations should be followed to insure successful repairs.

- Remove the pump from the application.
- Cleanliness is extremely important.
- Clean the port areas thoroughly before disconnecting the hydraulic lines.
- Plug the pump ports and cover the open hydraulic lines immediately after they're disconnected.
- Drain the oil and clean the exterior of the pump before making repairs.
- Wash all metal parts in clean solvent.
- Use compressed air to dry the parts. Do not wipe them dry with paper towels or cloth.
- The compressed air should be filtered and moisture free.
- Always use new seals when reassembling hydraulic pumps.
- For replacement parts and ordering information refer to parts list 6-632.
- Lubricate the new rubber seals with a petroleum jelly (vaseline) before installation.
- Torque all bolts over gasketed joints, then repeat the torquing sequence to make-up for gasket compression.
- Verifying the accuracy of pump repairs on an authorized test stand is essential.

# Identification and Tools Required

## Identification Numbers

Stamped on each unit.

### A - Product Number Description

- 70142 = Piston Pump (20.3 cm<sup>3</sup>/r [1.24 in<sup>3</sup>/r]) with Gerotor
- 70144 = Piston Pump (20.3 cm<sup>3</sup>/r [1.24 in<sup>3</sup>/r]) without Gerotor
- 70145 = Piston Pump (23.6 cm<sup>3</sup>/r [1.44 in<sup>3</sup>/r]) with or without Gerotor
- 78113 = Tandem Piston Pumps (20.3 cm<sup>3</sup>/r [1.24 in<sup>3</sup>/r]) **no Gear Pump**
- 78114 = Tandem Piston Pumps (20.3 cm<sup>3</sup>/r [1.24 in<sup>3</sup>/r]) with Gear Pump
- 78115 = Tandem Piston Pumps (23.6 cm<sup>3</sup>/r [1.44 in<sup>3</sup>/r]) **no Gear Pump**
- 78116 = Tandem Piston Pumps (23.6 cm<sup>3</sup>/r [1.44 in<sup>3</sup>/r]) with Gear Pump

### B - Rotation,

- R = Righthand,
- L = Lefthand

### C - Sequential Letters

### D - Design Code Number

## Single Pump - Product Number

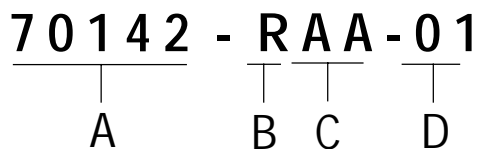

## Tandem Pumps - Product Number

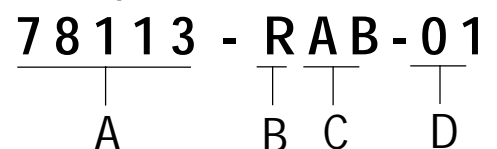

## Serial Number Code:

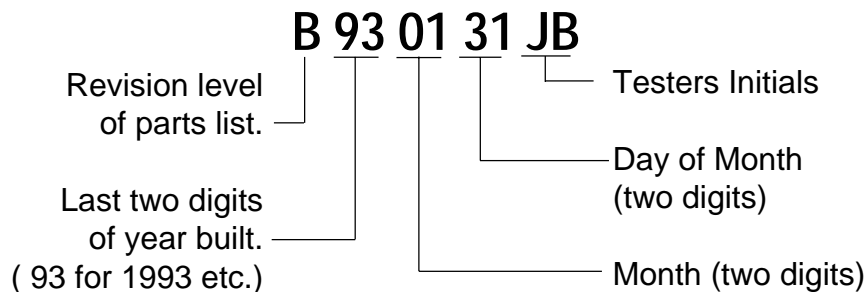

## Required Tools

- 7/16 in. Hex Key (Allen)
- 9/16 in. End Wrench
- 1 in. End Wrench
- 9/16 in. Socket
- 1/2 in. Socket
- Internal Retaining Ring Pliers (straight .090 tip)
- External Retaining Ring Pliers (straight .070 tip)
- O-ring Pick
- Torque Wrench (135.6 N·m [100 lbf·ft] capacity)
- Hammer (soft face)
- Light Petroleum Jelly
- Seal Driver
- Arbor Press

# Parts Drawing - Figure 1-1

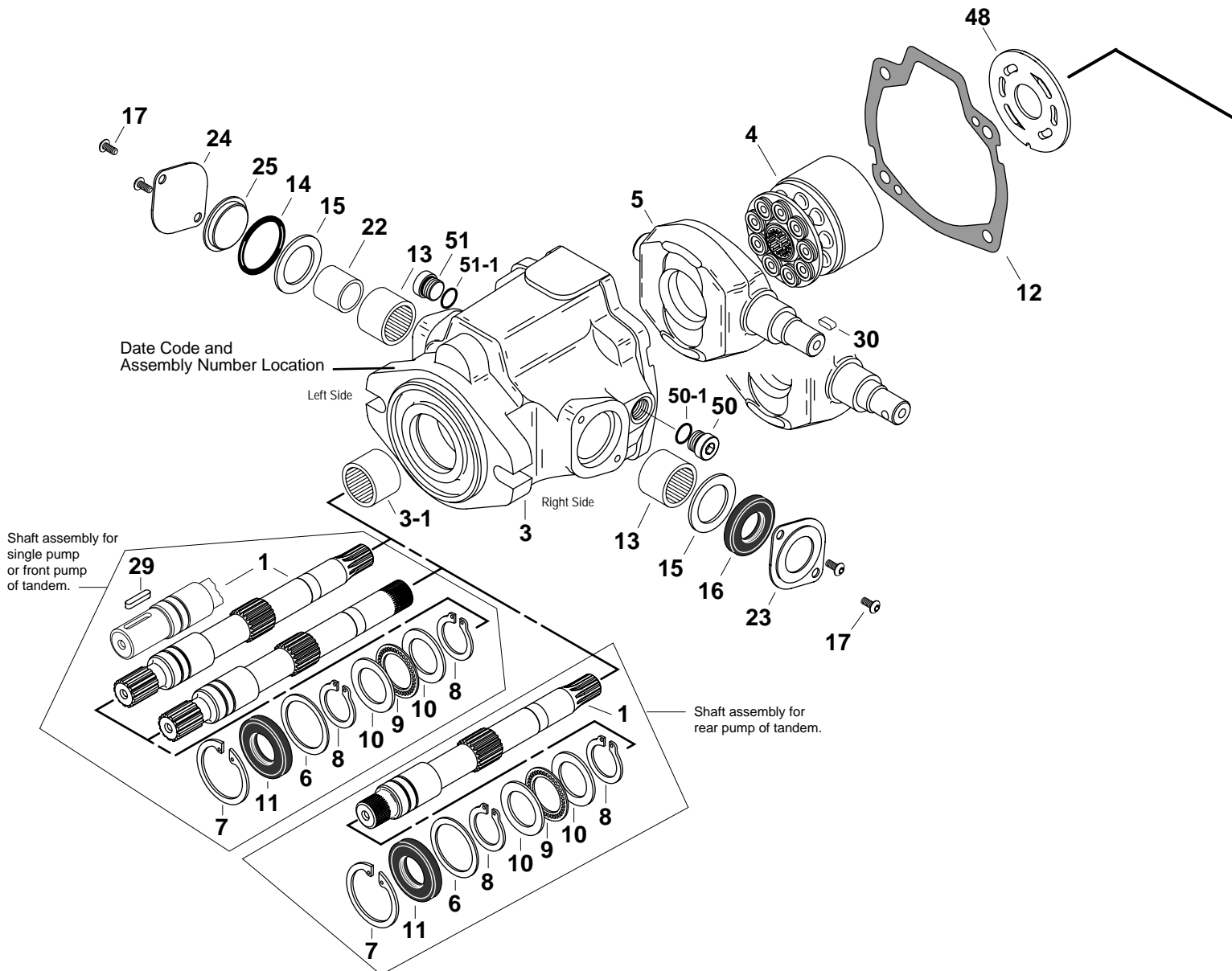

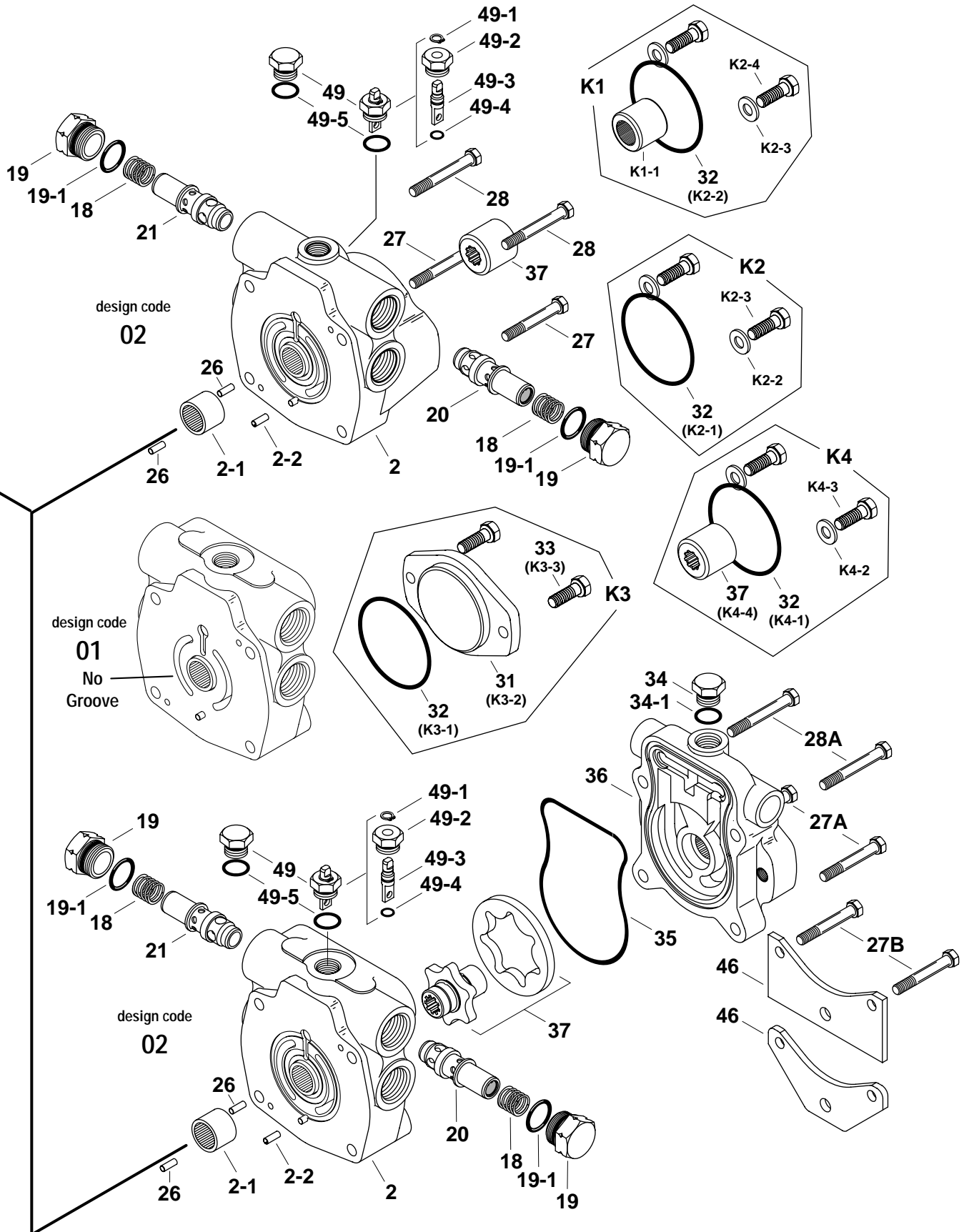

# Parts List

Item	Qty.	Description
1	1	Drive Shaft
2	1	Backplate Assembly
3	1	Housing Assembly
4	1	Rotating Kit Assembly
5	1	Camplate
6	1	Washer
+ 7	1	Retaining Ring
+ 8	2	Retaining Ring
9	1	Thrust Bearing
10	2	Bearing Race
+ 11	1	Shaft Seal, Drive
+ 12	1	Housing Gasket
13	2	Needle Bearing
+ 14	1	O-ring, 3.175 mm Dia. x 31.75 mm ID. [.125 in. Dia. x 1.25 in. ID.]
15	2	Washer
+ 16	1	Shaft Seal, Trunnion
17	4	Screw, Pan Head
18	2	Spring
19	2	Plug Assembly
+ 19-1	2	O-ring, 2.38 mm Dia. x 22.23 mm ID. [.0937 in. Dia. x .875 in. ID.]
20	1	Relief Valve for Port "C"
21	1	Relief Valve for Port "D"
22	1	Inner Race
23	1	Seal Cover
24	1	Trunnion Cover
25	1	Cover, O-ring
26	2	Dowel Pin
27	2	Cap Screws, 5/16-18, 50.8 mm [2 in.] Long
28	2	Cap Screws, 5/16-18, 63.5 mm [2.5 in.] Long
29	1	Key, Drive Shaft
30	1	Key, Camplate Trunnion
31	1	Cover Plate (In K3 kit)
+ 32	1	O-ring (In K1, K2, K3 & K4 kit)
33	2	Cap Screws, Cover Plate (In K3 kit)
34	1	Plug Assembly
+ 34-1	1	O-ring, 2.21 mm Dia. x 16.36 mm ID. [.087 in. Dia. x .644 in. ID.]
+ 35	1	Molded O-ring
36	1	Charge Pump Adaptor
37	1	Gerotor set and coupler sub-assembly 6.9 cm <sup>3</sup> /r [.42 in <sup>3</sup> /r] displacement, 6.35 mm [.25 in.] width 13.8 cm <sup>3</sup> /r [.84 in <sup>3</sup> /r] displacement, 12.7 mm [.5 in.] width
37	1	9 tooth coupler (In K4 kit)
46	1	Mounting Bracket, Square shaped
46	1	Mounting Bracket, "V" shaped
48	1	Valve Plate



## Parts List

Item	Qty.	Description
49	1	Dump Valve sub-assembly
+ 49-1	1	Retaining Ring
49-2	1	Separator Plug
49-3	1	Separator
+ 49-4	1	O-ring, 1.59 mm Dia. x 9.53 mm I.D. [.0625 in. Dia. x .375 in. I.D.]
+ 49-5	1	O-ring, 2.46 mm Dia. x 19.18 mm I.D. [.097 in. Dia. x .755 in. I.D.]
49	1	Plug Assembly
49-5	1	O-ring, 2.46 mm Dia. x 19.18 mm I.D. [.097 in. Dia. x .755 in. I.D.]
50	1	Plug Assembly
+ 50-1	1	O-ring, 1.98 mm Dia. x 11.89 mm ID. [.078 in. Dia. x .468 in. ID.]
51	1	Plug Assembly
+ 51-1	1	O-ring, 1.98 mm Dia. x 11.89 mm ID. [.078 in. Dia. x .468 in. ID.]

## Mounting Kits

K1	1	Tandem Piston Pump Mounting Kit
K1-1	1	35T Coupler, 36.8 mm [1.45 in.] long
K1-2	1	O-ring, 1.59 mm Dia. x 101.6 mm ID. [.0625 in. Dia. x 4 in. ID.]
K1-3	2	Cap Screws
K1-4	2	Washer
K2	1	Gear Pump Mounting Kit
K2-1	1	O-ring, 1.59 mm Dia. x 82.55 mm ID. [.0625 in. Dia. x 3.25 in. ID.]
K2-2	2	Washer
K2-3	2	Cap Screws
K3	1	Cover Plate Kit
K3-1	1	O-ring, 1.59 mm Dia. x 82.55 mm ID. [.0625 in. Dia. x 3.25 in. ID.]
K3-2	1	Cover Plate
K3-3	2	Cap Screws
K4	1	Gear Pump Mounting Kit with Coupler
K4-1	1	9T Coupler
K4-2	1	O-ring, 1.59 mm Dia. x 101.6 mm ID. [.0625 in. Dia. x 4 in. ID.]
K4-3	2	Cap Screws
K4-4	2	Washer

## Seal Repair Kit

70142-938	Seal Repair Kit for 70142, 70144 and 70145 piston pump.
-----------	---

**Legend**                    +      Included in seal repair kit.

# Disassembly

## Disassembly

The following instructions apply to a variable displacement piston pump with or without a gerotor charge pump. A tandem pump assembly should be separated into individual pumps before disassembly.

1 Position the pump into a protected jaw vise, clamping onto the outer portion of the flange, with the input drive shaft down. Remove the four cap screws retaining charge pump adapter or backplate.

No gerotor charge pump skip to step 6.

2 Lift the charge pump adapter assembly straight up off backplate, shaft, and gerotor. Gerotor may stay in adapter or on backplate.

3 Remove o-ring from charge pump adapter.

4 Remove outer gerotor ring from either the charge pump adapter or the inner gerotor ring.

Refer to Appendix A for disassembly and inspection of charge pump adapter assembly.

5 Remove the inner gerotor ring and coupler assembly from shaft.

6 Lift backplate straight up off of shaft and housing. Remove valve plate from backplate or from rotating kit assembly, still in housing.

7 From backplate remove dump valve assembly or plug assembly, and relief valve assemblies. Note: Mark the relief valve in relationship to the cavity it was removed, for reassembly purposes.

### Backplate Inspection:

- Check the bearing (press fit) in backplate. If needles remain in cage, move freely, and setting is at the dimension shown in figure 1-3, removal not required.

- Check roll pin in backplate. If tight and set to the dimension shown in figure 1-3, removal not required.

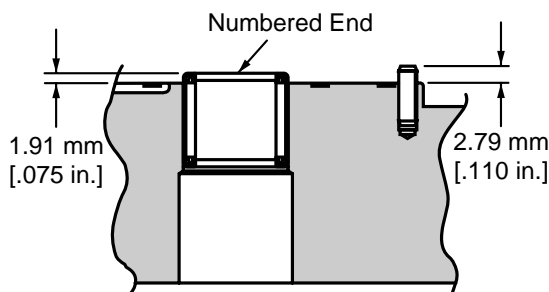

Figure 1-3

8 Remove housing gasket from housing or backplate.

9 To remove rotating kit assembly from housing, first remove pump from vise holding the rotating kit assembly in position. Lower pump so that the shaft end (flange end) is up. Set the rear of housing onto table with housing flat and rotating kit assembly at rest on table. Hole in table for protruding shaft is required. Remove by lifting the housing and shaft from rotating kit assembly.

Refer to Appendix B for disassembly and Inspection of rotating kit.

10 Remove retaining ring from the front of housing. Press the shaft, shaft seal or spacer, and washer from housing. Remove retaining ring, thrust washer, thrust bearing, second thrust washer, and second retaining ring from shaft.

11 To remove camplate from housing, remove the two screws from both sides of housing (four total) retaining seal cover and trunnion cover. Remove seal cover, shaft seal, washer, and bearing from housing. Remove trunnion cover, o-ring cover, o-ring, washer, inner race, and bearing from housing. Slide the camplate over to one side and remove thru the back side of housing.

### Camplate Inspection:

- The finish on the piston shoe surfaces of the camplate should show no signs of scoring.

### Housing Inspection:

- Check the bearing (press fit) in front of housing. If needles remain in cage, move freely, and setting at the dimension shown in figure 1-4, removal not required.

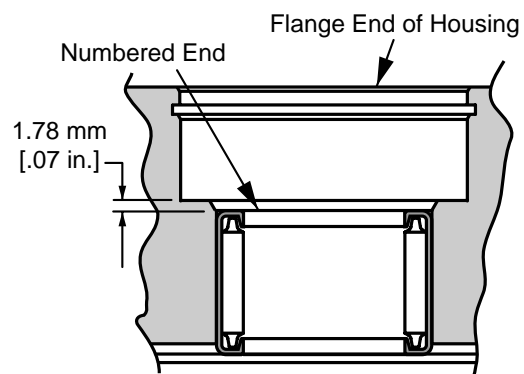

Figure 1-4

12 Discard the shaft seal, gaskets, and o-rings from all assemblies. Replace with new seals upon reassembly.

# Reassembly

## Reassembly

- 1 All parts should be cleaned and critical moving parts lubricated before reassembly.
- 2 If necessary, press new bearing in housing to dimension shown in figure 1-4 with the numbered end of bearing outward.
- 3 Starting with the camplate, insert camplate into the housing with the long trunnion side down and to the appropriate side of linkage on the machine.
- 4 On the short trunnion side of camplate install bearing (bearing with numbered side to the inside of pump), bearing race (race with chamfer toward inside of pump), washer, o-ring, o-ring cover, trunnion cover, and retain with two screws. Torque screws 4.1 to 5.4 N·m [36 to 48 lbf·in].
- 5 On the long trunnion side of camplate install bearing (bearing with numbered side to the inside of pump), washer, trunnion shaft seal, seal cover, and retain with two screws. Torque screws 4.1 to 5.4 N·m [36 to 48 lbf·in].
- 6 To install shaft, place exterior retaining ring, thrust race, thrust bearing, second thrust race, and second retaining ring onto shaft. Position washer and shaft seal or spacer onto shaft.
- 7 Install shaft assembly into front of housing: For units with spacer, retain with interior retaining ring and go on to step 8. For units with shaft seal, seat seal into position with seal driver and retain with interior retaining ring.  
Refer to Appendix B for reassembly of rotating kit assembly.
- 8 With flange end of housing up, position rotating kit assembly onto shaft and into housing. Align the spline within the piston block with shaft internal spline. Make sure piston block is engaged fully to put piston shoes in contact with camplate. Check all parts for proper position before proceeding.
- 9 Clamp pump assembly in a protected jaw vise with the open end of the housing up. Install gasket and two dowel pins onto housing.
- 10 If necessary, press new bearing and roll pin in backplate to dimension shown in figure 1-3. Bearing installed with the numbered end outward. Roll pin installed with split oriented away from bearing.
- 11 Install new o-ring on relief valves. Install relief valve in its original cavity in backplate that it was removed. Torque 128 to 142 N·m [95 to 105 lbf·ft.]
- 12 Install new o-ring on dump valve or plug. Install dump valve or plug into backplate. Torque dump valve or plug to 36.6 to 40.7 N·m [ 27 to 30 lbf·ft]
- 13 Apply a small amount of petroleum jelly to the steel side of valve plate to hold in place for installation. Aligning the index pin, place the valve plate in position onto the backplate, with steel side against backplate.
- 14 Install backplate assembly onto housing assembly. Making sure valve plate and gasket stay in place.  
No gerotor charge pump, skip to step 17.
- 15 Install inner gerotor and coupler assembly. The coupler has a "V" groove on one end and this end of coupler should enter backplate first. Lubricate inner gerotor.  
Refer to Appendix A for reassembly of Charge relief valve in adapter plate.
- 16 Install o-ring and outer gerotor ring onto adapter plate. Lubricate both o-ring and outer gerotor ring to hold in position during assembly of adapter plate. Install adapter plate onto backplate. Make sure o-ring and gerotor ring stay in place.
- 17 Retain backplate and adapter plate (when used) with four cap screws, Torque 23 to 27 N·m [17 to 20 lbf·ft].
- 18 Install new o-rings on all plugs. Install plugs into housing. Torque 9/16 in. - 18 plug 28 to 32 N·m [21 to 24 lbf·ft].
- 19 Refer to start-up procedures on page 17.

# Appendix A - Charge Pump Adapter Assembly

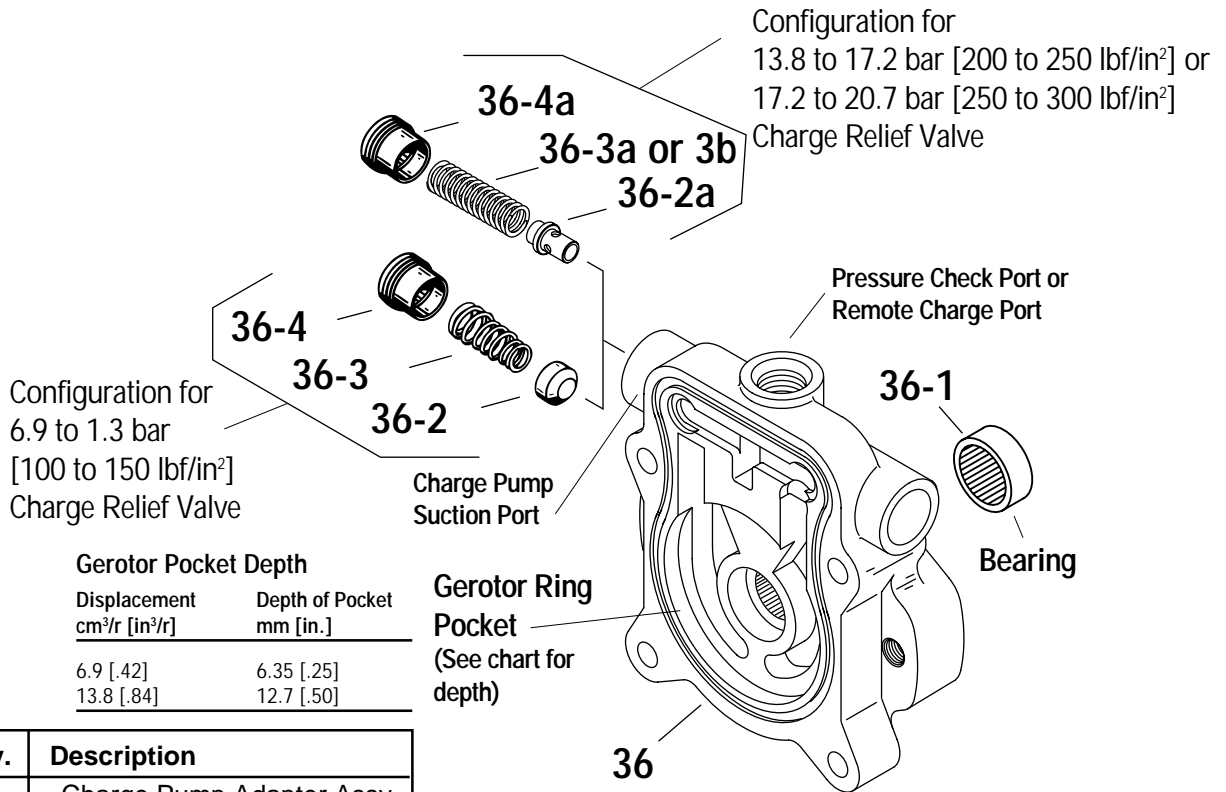

Gerotor Pocket Depth	
Displacement cm <sup>3</sup> /r [in <sup>3</sup> /r]	Depth of Pocket mm [in.]
6.9 [.42]	6.35 [.25]
13.8 [.84]	12.7 [.50]

Item	Qty.	Description
36	1	Charge Pump Adapter Assy.
36-1	1	Bearing (press fit)
36-2	1	Poppet, Cup
36-2a	1	Poppet, Pin
36-3	1	Spring, Tapered
36-3a	1	Spring, "Light Green" *
36-3b	1	Spring, "Pink" **
36-4	1	Spring Retainer
36-4a	1	Spring Retainer

\*200 to 250 lbf/in<sup>2</sup>  
 \*\*250 to 300 lbf/in<sup>2</sup>

## Reassembly - Charge Pump Adapter Assembly

- 1 If necessary, press new bearing in adapter assembly. The bearing to dimension shown in figure 1-2 with the numbered end of bearing outward and closest to mounting flange.
- 2 Install cup poppet or pin poppet, spring, and spring retainer into charge pump adapter. Torque retainer 6.8 to 9.5 N·m [5 to 7 lbf·ft.]

## Disassembly - Charge Pump Adapter Assembly

1 Remove spring retainer, spring, and poppet from adapter assembly.

### Inspection:

- Inspect the charge pump relief valve seat inside the charge pump adapter. Check to insure that seat is smooth and free of burrs or other defects.
- Inspect the charge pump relief valve spring.
- Inspect the bearing inside the charge pump adapter. The bearing needles must remain in the bearing cage and bearing at dimension shown in figure 1-2.
- Inspect the gerotor pocket inside the charge pump adapter assembly. It should not be scored excessively.

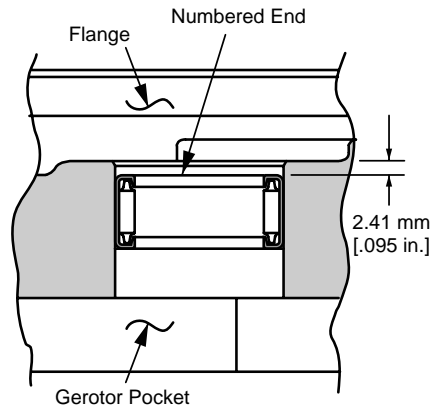
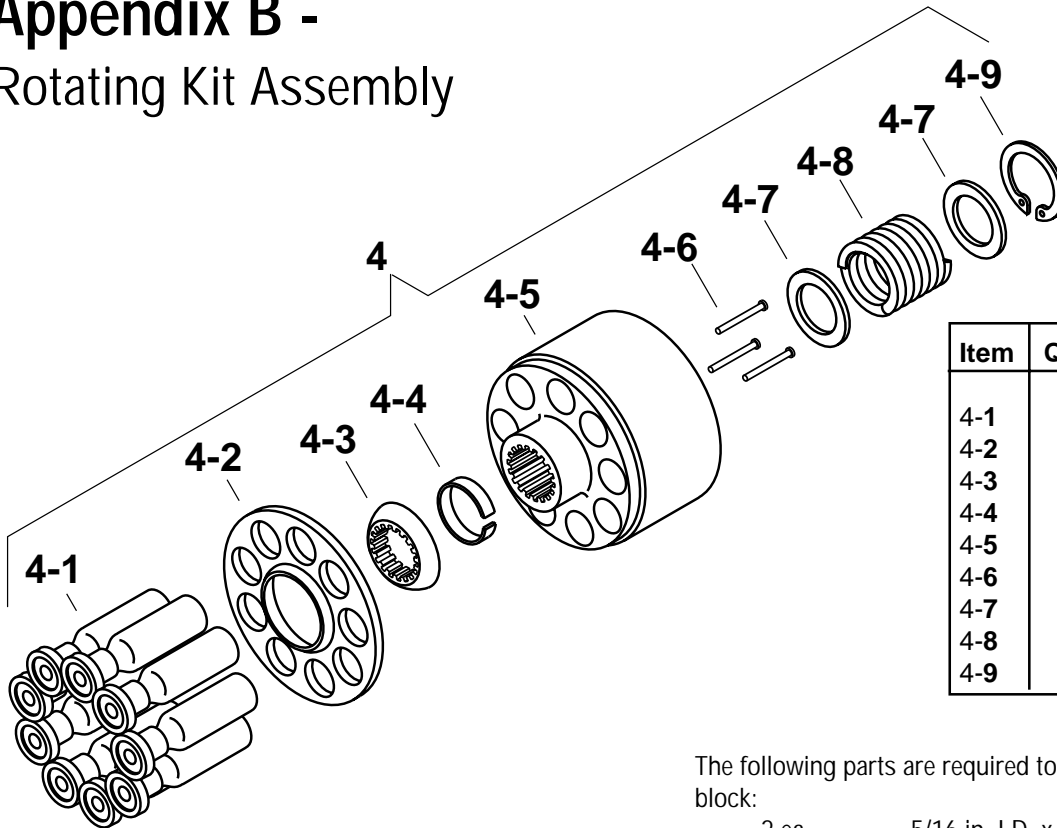

Figure 1-2

# Appendix B - Rotating Kit Assembly



Item	Qty.	Description
4-1	9	Piston assemblies
4-2	1	Spider
4-3	1	Spider Pivot
4-4	1	Retainer
4-5	1	Piston Block
4-6	3	Pins
4-7	2	Washer
4-8	1	Spring
4-9	1	Retaining Ring

## Disassembly - Rotating Kit Assembly

Disassembly of rotating assembly is required for inspection only.

- 1 Remove the nine piston assemblies, spider, and spider pivot from piston block.

### Inspection:

- Examine the O.D. of the pistons for finish condition. They should not show wear or deep scratches. Inspect the shoes for a snug fit on the ball end of the pistons and a flat smooth surface that comes in contact with the camplate. **Do not lap piston shoes.**
- Examine the spider for wear in the pivot area.
- Examine the pivot to insure smoothness and no signs of wear.
- Inspect the piston block surface that makes contact with valve plate. This surface should be smooth and free of deep scratches. **Do not lap piston block.**
- The pistons should move freely in the piston block bore. If not free moving, examine the bore for scoring or contamination.

- 2 To inspect pins and spring **Caution** should be taken in removing spring. The **spring is highly compressed** and the retaining ring should not be removed without compressing the spring safely.

The following parts are required to disassemble the piston block:

- 2 ea. 5/16 in. I.D. x 15/16 in. O.D. flat washers
- 1 ea. 5/16 in. x 2-7/8 in. N.C. cap screw, and
- 1 ea. 5/16 in. N.C. nut

To remove spring, place one of the flat washers over the 5/16 in. x 2-7/8 in. cap screw. Put cap screw through the center of the piston block and apply the second washer. Let washer rest on the three pins and retain with nut. Turning nut and compressing spring inside the block. Use a pair of retaining ring pliers and remove the internal retaining ring. Remove nut, bolt, and the two washers from block. Removing the washer, spring, second washer, three pins, and pin keeper at the same time.

## Reassembly - Rotating Kit Assembly

- 1 To reassemble the rotating kit assembly complete the following: Compress the pin keeper and install in the spline of the piston block. Install the three pins with head end to the inside of the block and position in the special grooves of the piston block spline.
- 2 Install the washer, spring, and second washer into the piston block. Use the two 5/16 in. I.D. washers, nut, and 5/16 in. x 2-7/8 in. cap screw to compress the spring and retain with retaining ring. Remove the nut, cap screw, and the two washers.
- 3 Install the pivot onto the three pins, spider on the pivot, and piston assemblies thru the spider and into piston block, resting on spider.

# Fault - Logic Trouble Shooting

This fault - logic trouble shooting guide is a diagnostic aid in locating transmission problems.

Match the transmission symptoms with the problem statements and follow the action steps shown in the box diagrams. This will give expedient aid in correcting minor problems eliminating unnecessary machine down time.

Following the fault - logic diagrams are diagram action comments of the action steps shown in the diagrams. Where applicable, the comment number of the statement appears in the action block of the diagrams.

## Explanatory Diagram

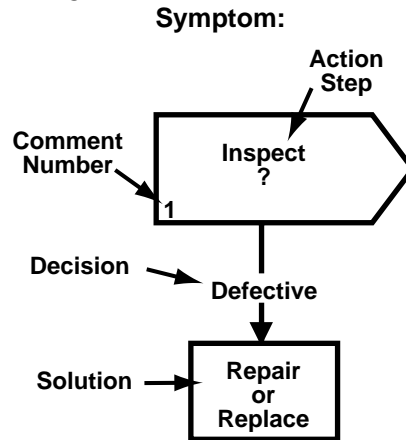

## Recommended Gauge Locations

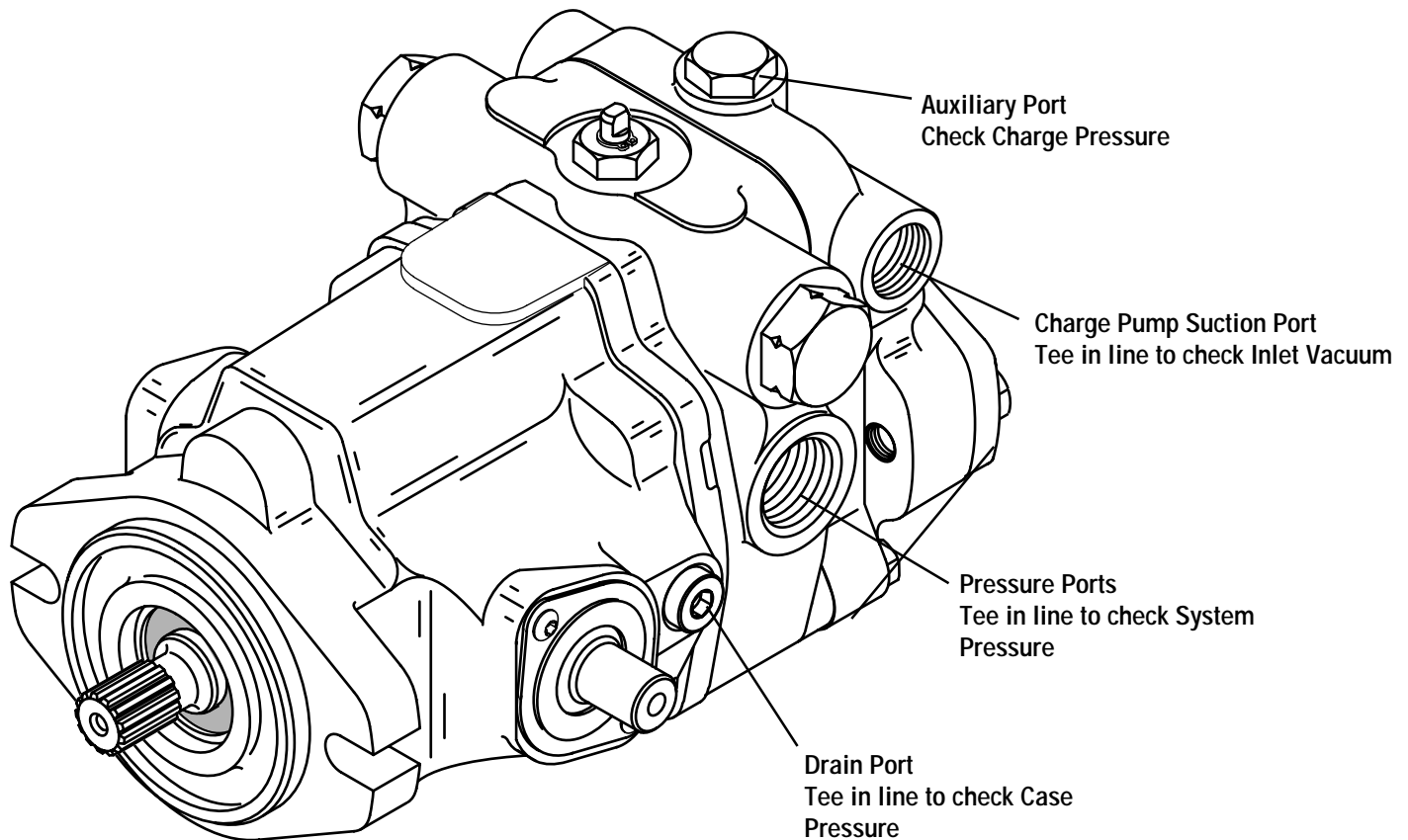

Figure 3-1

### Gauges Recommended

Inlet vacuum gauge: 207 bar to 0 bar [30 lbf/in<sup>2</sup> to 30 inHg]

System pressure gauge: 700 bar [10,000 lbf/in<sup>2</sup>]

Charge pressure gauge: 0 to 50 bar [0 to 600 lbf/in<sup>2</sup>]

Case pressure gauge: 0 to 25 bar [0 to 300 lbf/in<sup>2</sup>]

# Fault - Logic Trouble Shooting

## Symptom: Neutral Difficult or Impossible to Find

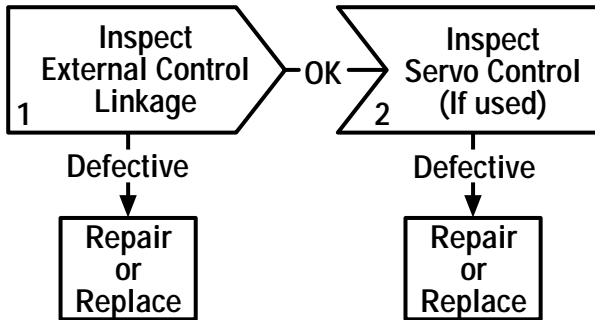

## Symptom: System Operating Hot

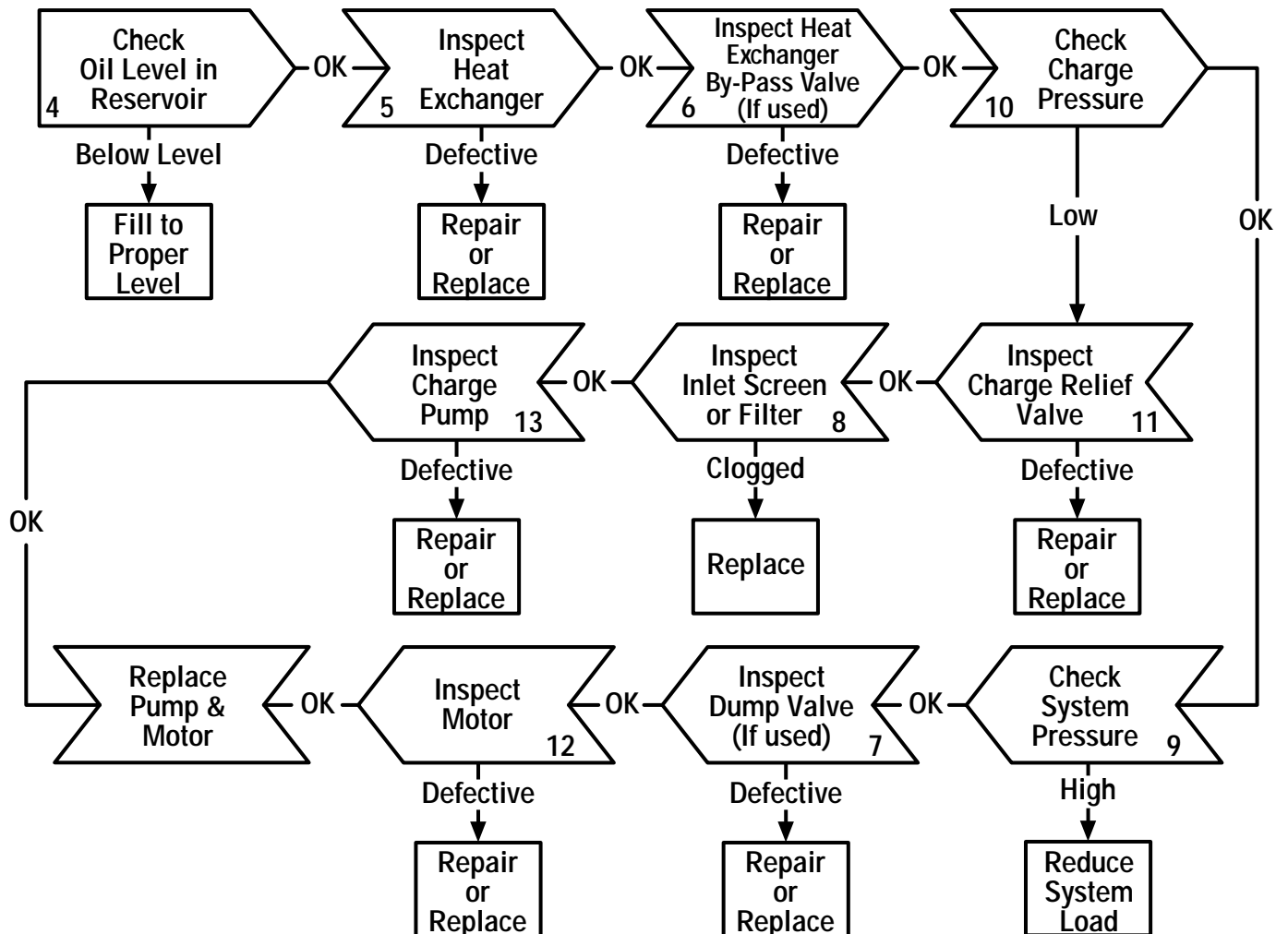

# Fault - Logic Trouble Shooting

## Symptom: Operates in One Direction Only

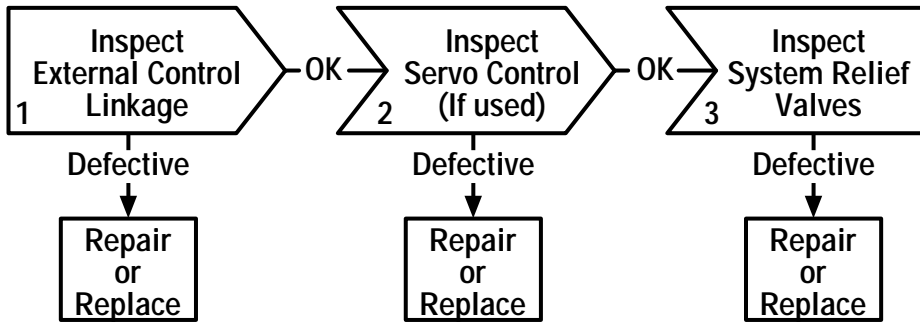

## Symptom: System Response Sluggish

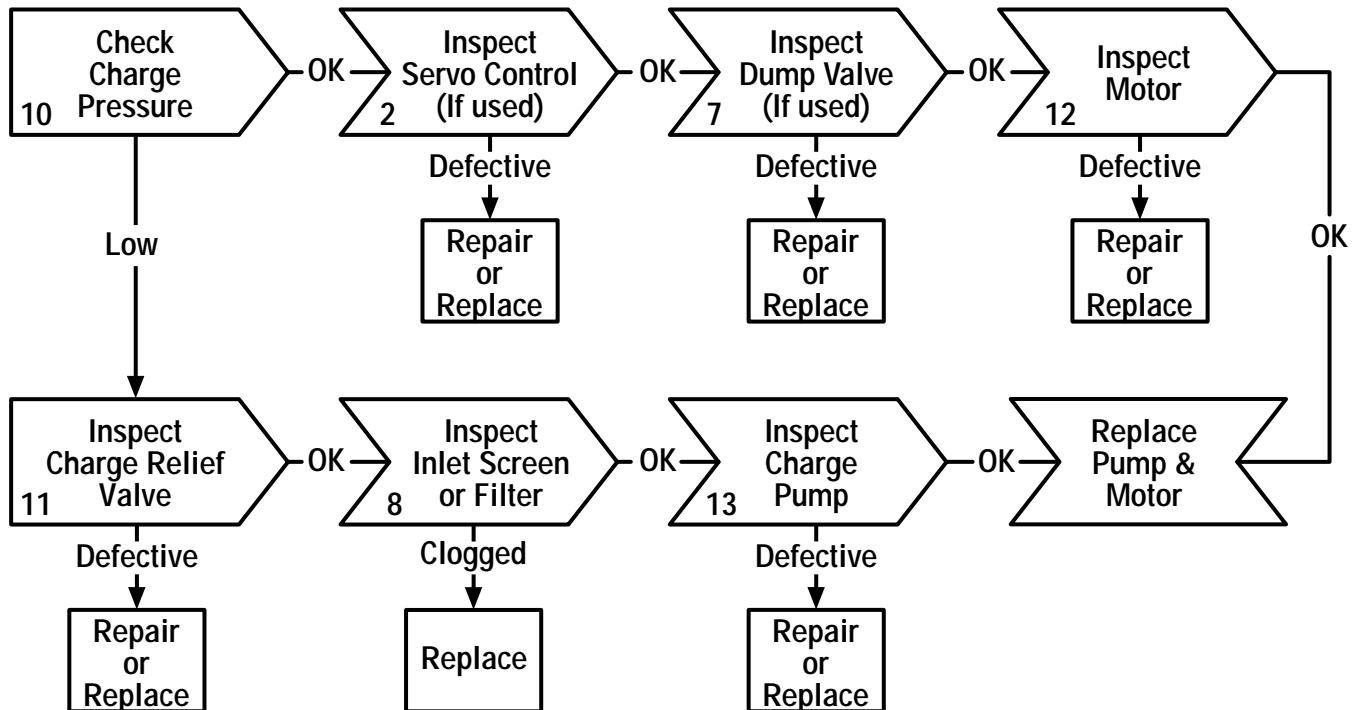



# Fault - Logic Trouble Shooting

Symptom: System Will Not Operate In Either Direction

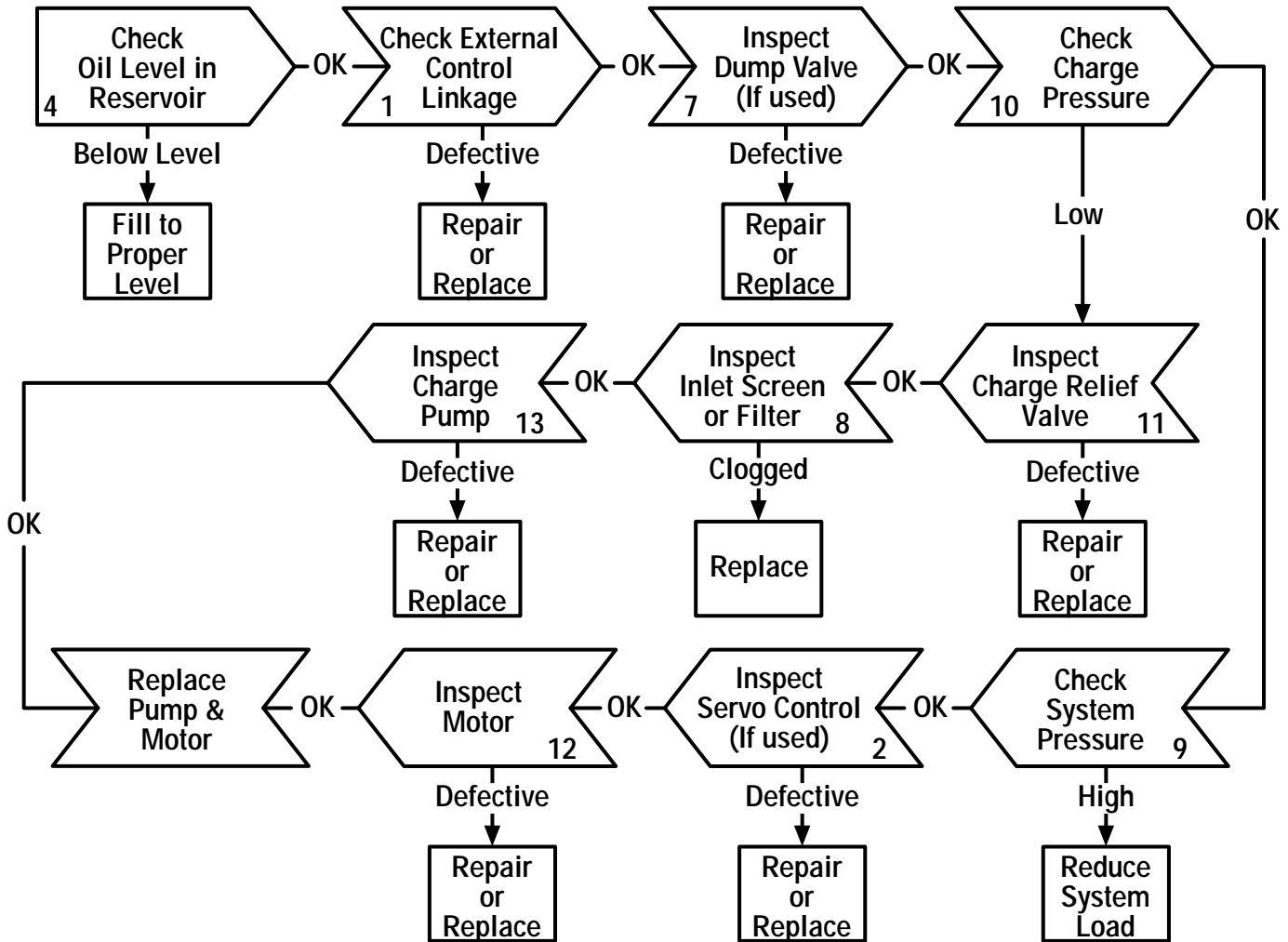

# Fault - Logic Trouble Shooting

## Diagram Action Step Comments

- 1 **Inspect External Control Linkage for:**
  - a. misadjusted or disconnected
  - b. binding, bent, or broken
  - c. misadjusted, damaged or broken neutral return spring
- 2 **Inspect Servo Control Valve for: (if used)**
  - a. proper inlet pressure
  - b. misadjusted, damaged or broken neutral return spring
  - c. galled or stuck control spool
  - d. galled or stuck servo piston
- 3 **Inspect System Relief Valves \* for:**
  - a. improper pressure relief setting
  - b. damaged or broken spring
  - c. valve held off seat
  - d. damaged valve seat
- 4 **Check Oil Level in Reservoir:**
  - a. consult owner/operators manual for the proper type fluid and level
- 5 **Inspect Heat Exchanger for:**
  - a. obstructed air flow (air cooled)
  - b. obstructed water flow (water cooled)
  - c. improper plumbing (inlet to outlet)
  - d. obstructed fluid flow
- 6 **Inspect Heat Exchanger By-Pass Valve for: (if used)**
  - a. improper pressure adjustment
  - b. stuck or broken valve
- 7 **Inspect Dump Valve for: (if used)**
  - a. held in a partial or full open position
- 8 **Inspect Inlet Screen or Filter for:**
  - a. plugged or clogged screen or filter element
  - b. obstructed inlet or outlet
  - c. open inlet to charge pump
- 9 **Check System Pressure:**
  - a. See figure 3-1 for location of pressure gauge installation.
  - b. consult owner/operators manual for maximum system relief valve settings
- 10 **Check Charge Pressure:**
  - a. See figure 3-1 for location of pressure gauge installation.
  - b. consult owner/operators manual for maximum charge relief valve settings

- 11 **Inspect Charge Relief Valve for:**
  - a. improper charge relief pressure setting \*
  - b. damaged or broken spring
  - c. poppet valve held off seat
- 12 **Inspect Motor for:**
  - a. disconnected coupling
- 13 **Inspect Charge Pump for:**
  - a. broken or missing drive key
  - b. damaged or missing o-ring
  - c. excessive gerotor clearance
  - d. galled or broken gerotor set

**\* System/Charge Relief Valve  
Pressure Settings for  
Eaton's Variable Displacement  
Controlled Piston Pumps**

Inlet Vacuum	6 inHg max.
Case Pressure	25 lbf/in <sup>2</sup> maximum
Charge Pressure	100 to 150 lbf/in <sup>2</sup> Standard 200 to 250 lbf/in <sup>2</sup> Optional 250 to 300 lbf/in <sup>2</sup> Optional
System Pressure	5000 lbf/in <sup>2</sup> maximum 3000 lbf/in <sup>2</sup> continuous

The high pressure relief valves are all factory preset and cannot be readjusted.

The pressure setting and assembly number is stamped on each high pressure relief valve cartridge.

Valve Identification Example:

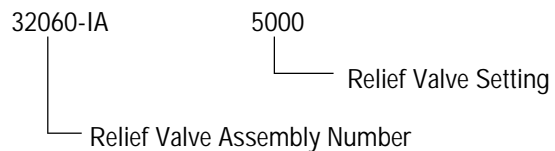

# Start-up Procedure

When initially starting a new or a rebuilt transmission system, it is extremely important that the start-up procedure be followed. It prevents the chance of damaging the unit which might occur if the system was not properly purged of air before start-up.

- 1 After the transmission components have been properly installed, fill the pump housing at least half full with filtered system oil. Connect all hydraulic lines and check to be sure they are tight.
- 2 Install and adjust all control linkage.
- 3 Fill the reservoir with an approved oil that has been filtered through a 10 micron filter. Refer to Eaton Hydraulics Technical Data sheet number 3-401 titled [Hydraulic Fluid Recommendations](#).
- 4 Gasoline or L.P. engines: remove the coil wire and turn the engine over for 15 seconds. Diesel engines: shut off the fuel flow to the injectors and turn the engine over for 15 seconds.
- 5 Replace the coil wire or return the fuel flow to the injectors. Place the transmission unit in the neutral position, start the engine and run it at a low idle. The charge pump should immediately pick up oil and fill the system. If there is no indication of fill in 30 seconds, stop engine and determine the cause.
- 6 After the system starts to show signs of fill, slowly move pump camplate to a slight cam angle. Continue to operate system slowly with no load on motors until system responds fully.
- 7 Check fluid level in the reservoir and refill if necessary to the proper level with an approved filtered oil.
- 8 Check all line connections for leaks and tighten if necessary.
- 9 The machine is now ready to be put into operation.
- 10 Frequent filter changes are recommended for the first two changes after placing the machine back into operation. Change the first filter in 3-5 hours and the second at approximately 50 hours approx. hours. Routinely scheduled filter changes are recommended for maximum life of the hydraulic system.

---

# Notes

---

# Notes

**Order parts from number 6-632 Parts Information booklet.  
Each order must include the following information.**

1. Product and/or Part Number
2. Serial Code Number
3. Part Name
4. Quantity

Eaton Corporation  
**Hydraulics Division**  
15151 Hwy. 5  
Eden Prairie, MN 55344  
Telephone 612/937-9800  
Fax 612/937-7130

Eaton Ltd.  
**Hydraulics Division**  
Glenrothes, Fife  
Scotland, KY7 4NW  
Telephone 44/592-771-771  
Fax 44/592-773-184

## CONTENTS

	Page
INTRODUCTION .....	7-3
LUBRICATION .....	7-4
ENGINE OIL .....	7-4
COOLING SYSTEM .....	7-4
ENGINE FAN BELT .....	7-5
TO REPLACE ENGINE FAN/ALTERNATOR BELT .....	7-5
AIR INTAKE SYSTEM .....	7-10
AIR FILTER .....	7-10
AIR FILTER INDICATOR (optional) .....	7-10
TO REPLACE AIR FILTER ELEMENT .....	7-11
FUEL SYSTEM - GASOLINE .....	7-13
FUEL FILTER .....	7-13
CARBURETOR .....	7-13
FUEL PUMP .....	7-13
FUEL SYSTEM - LPG .....	7-14
LP FUEL TANKS .....	7-16
LPG FUEL TANK STORAGE .....	7-18
TO CHANGE AN LPG FUEL TANK 7-19	7-21
FUEL FILTER LOCK .....	7-21
VAPORIZER-REGULATOR .....	7-21
CARBURETOR .....	7-21
OIL PRESSURE SWITCH .....	7-21
LPG FUEL TROUBLESHOOTING .....	7-22
CYLINDER HEAD .....	7-22
VALVE TAPPET CLEARANCE ...	7-22
CRANKCASE VENTILATION SYSTEM .....	7-22
GOVERNOR .....	7-23
TO ADJUST GOVERNOR CONTROL BOX .....	7-23
DIGITAL CONTROLLER SET-UP GOVERNOR	7-25
TROUBLESHOOTING .....	7-26
IGNITION SYSTEM .....	7-34
SPARK PLUGS .....	7-34
TO REPLACE SPARK PLUGS ...	7-34
FORD DISTRIBUTORLESS IGNITION SYSTEM 7-35	
RUN MODE .....	7-36
SERVICING AND TESTING .....	7-36
"FAILURE MODE OF DIS" IGNITION HARNESS .....	7-37
FORD DIS IGNITION .....	7-38
TO REPLACE ALTERNATOR ....	7-40
TO REPLACE STARTER .....	7-44
TO REMOVE ENGINE .....	7-48
TO INSTALL ENGINE .....	7-55

## GAS/LP ENGINE SERVICE MANUAL

FORD VSG-411/413

TENNANT Part Number 38978





---

**INTRODUCTION**

---

This section includes repair information on the engine and related systems, such as fuel, electrical, and drive belts.

## LUBRICATION

### ENGINE OIL

Check the engine oil level daily. Change the engine oil and oil filter every 50 hours of machine operation. Use 10W30 SAE-SG/SH rated engine oil.

Fill the engine with oil to the level indicated on the oil dipstick. The engine oil capacity is 4.7 L (5 qt) including the oil filter.

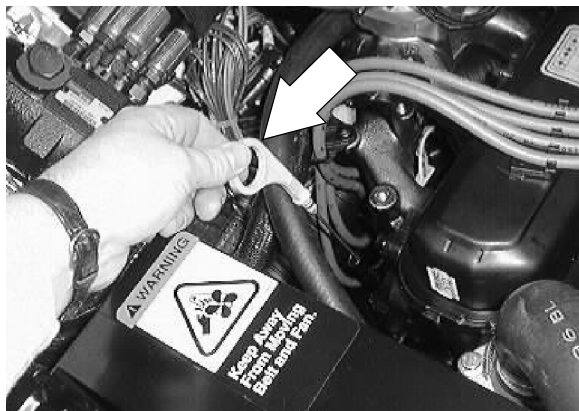

## COOLING SYSTEM

Check the radiator coolant level every 100 hours of operation. Use clean water mixed with a permanent-type, ethylene glycol antifreeze to a  $-34^{\circ}\text{C}$  ( $-30^{\circ}\text{F}$ ) rating.

**FOR SAFETY: When Servicing Machine, Avoid Contact With Hot Engine Coolant.**

Check the radiator hoses and clamps every 200 hours of operation. Tighten the clamps if they are loose. Replace the hoses and clamps if the hoses are cracked, harden, or swollen.

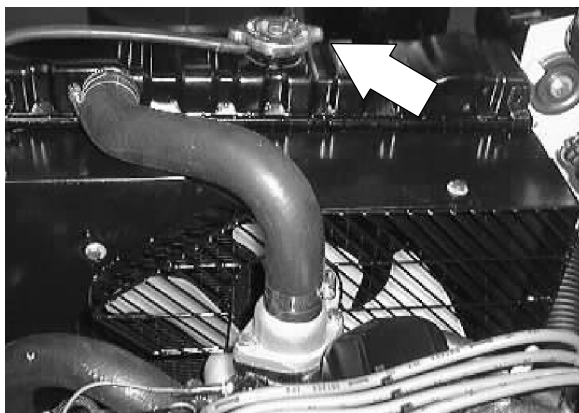

Check the radiator core exterior and hydraulic cooler fins for debris every 100 hours of operation. Blow or rinse all dust, which may have collected on the radiator, in through the engine fan and out the radiator fins, opposite the direction of normal air flow. Be careful not to bend the cooling fins when cleaning. Clean thoroughly to prevent the fins becoming encrusted with dust. Clean the radiator and cooler only after the radiator has cooled to avoid cracking.

**FOR SAFETY: When Servicing Machine, Wear Eye And Ear Protection When Using Pressurized Air Or Water.**

Flush the radiator and the cooling system every 400 hours of operation, using a dependable cleaning compound.

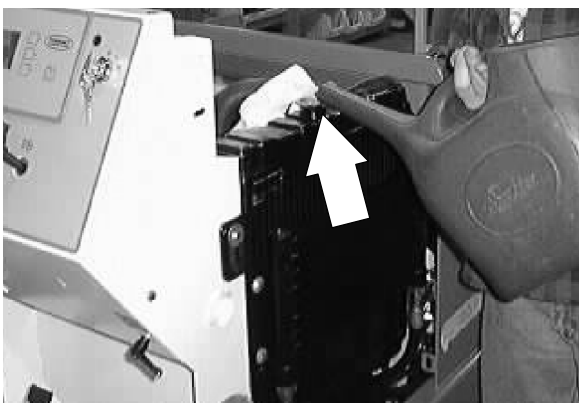

## ENGINE FAN BELT

The engine fan belt is driven by the engine crankshaft pulley and drives the alternator pulley. Proper belt tension is 9 to 10 mm (0.35 to 0.39 in) for a new belt and 10 to 11 mm (0.39 to 0.43 in) for a used belt with a force of 10 kg (22 lb).

Check and adjust the belt tension every 100 hours of operation.

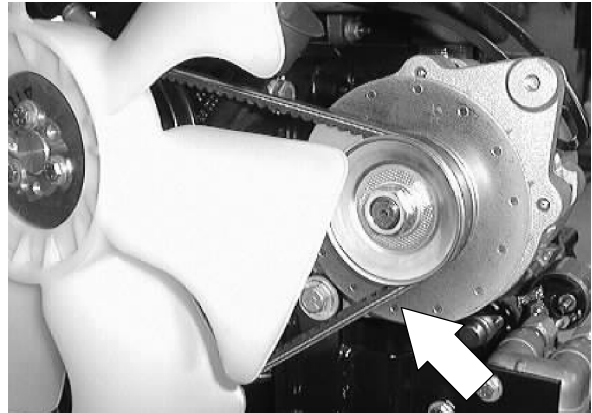

## TO REPLACE ENGINE FAN/ALTERNATOR BELT

1. Raise the hopper and engage the prop bar.

 **WARNING: Raised Hopper May Fall. Engage Hopper Support Bar.**

**FOR SAFETY: Before Leaving Or Servicing Machine; Stop On Level Surface, Set Parking Brake, Turn Off Machine And Remove Key.**

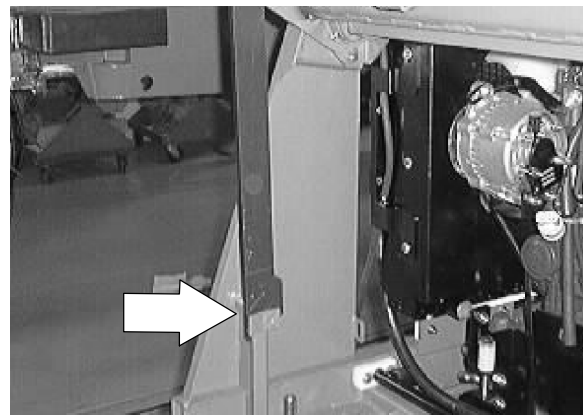

2. Open the engine cover and side door.



## ENGINE-GAS/LP

3. Disconnect the battery cables from the battery.

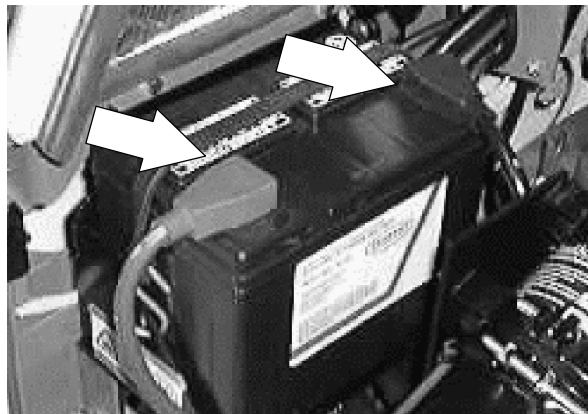

4. Pull the rubber dust shield away from the front of the engine in the area of the alternator.

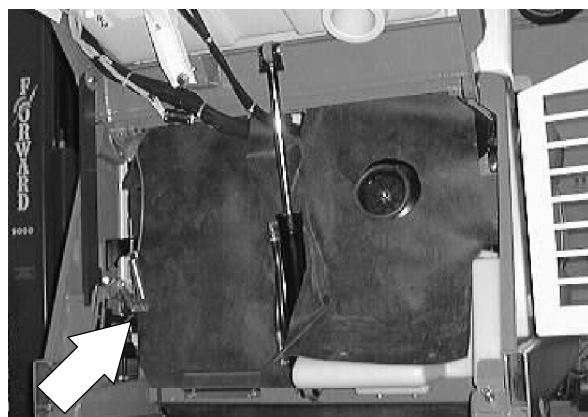

5. Go to the area of the machine in front of the engine. Locate the two hex screws and nuts holding the accessory pump pivot plate to the mount plate. *Loosen these two screws.*

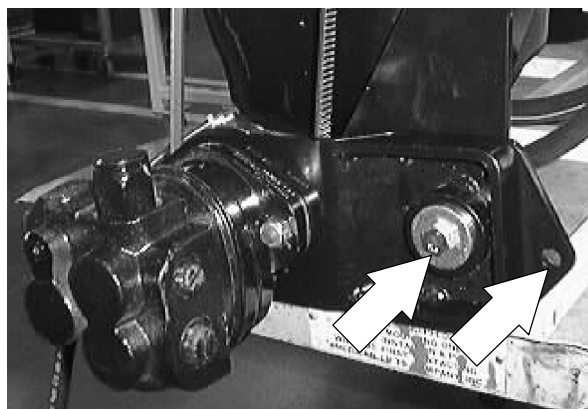

6. Locate the hex bolt and compression spring at the front of the accessory pump mount bracket. Loosen the hex bolt and compression spring. *Remove the accessory pump V-belt from the pump sheave.*

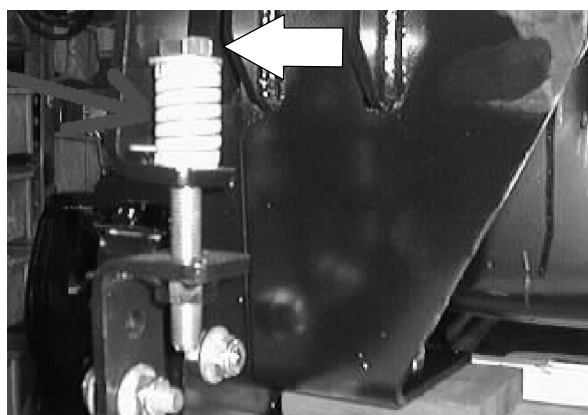

7. Loosen the hex screw holding the top of the alternator to the mount bracket.

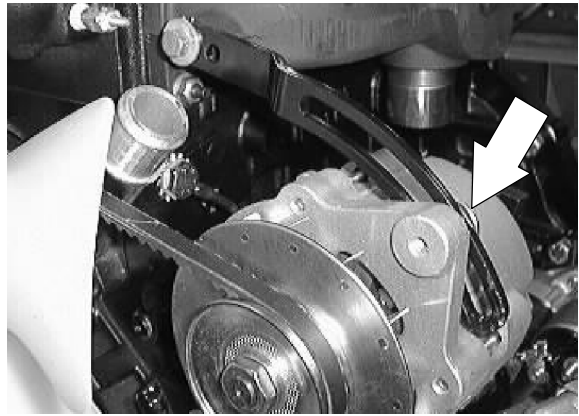

8. Loosen the hex screw and nyloc nut holding the bottom of the alternator to the lower mount bracket.

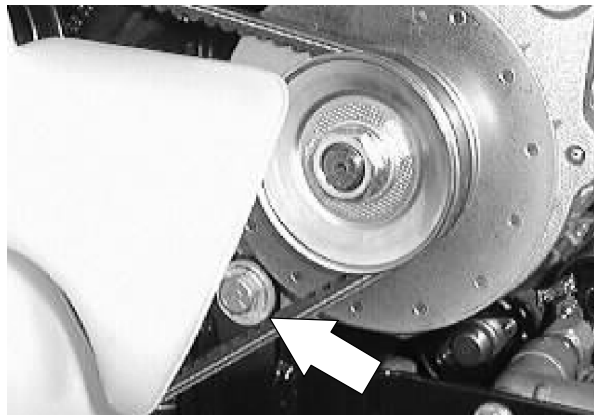

9. Push the alternator in toward the engine. Remove the V-belt from the alternator and engine pulleys.

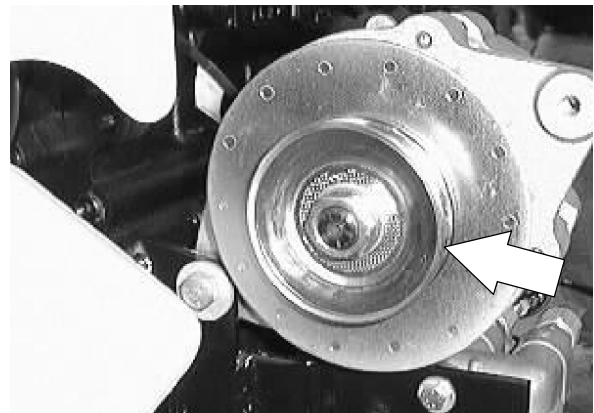

10. Position the new fan belt on the alternator pulley and engine pulleys.

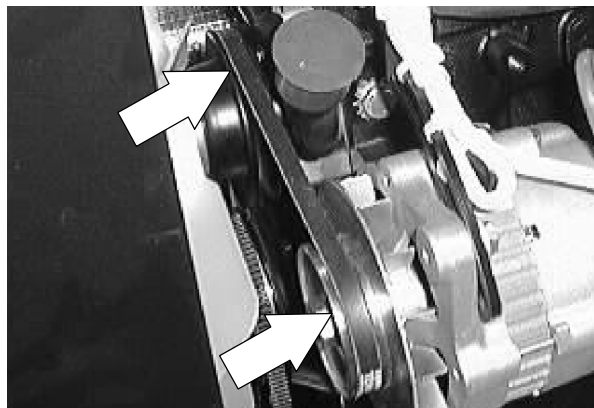

11. Pull the alternator away from the engine to tighten the belt. See adjustment in ENGINE FAN BELT description. Tighten the hex screw to 18 - 24 Nm (13 - 18 ft lb).

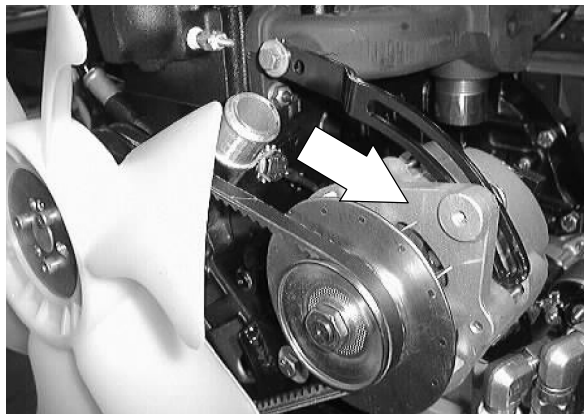

12. Tighten the bottom hex screw to 18 - 24 Nm (15 - 20 ft lb).

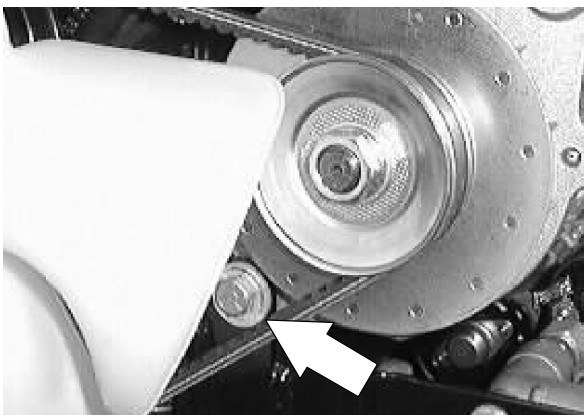

13. Install the hydraulic pump V-belt around the accessory pump sheave.

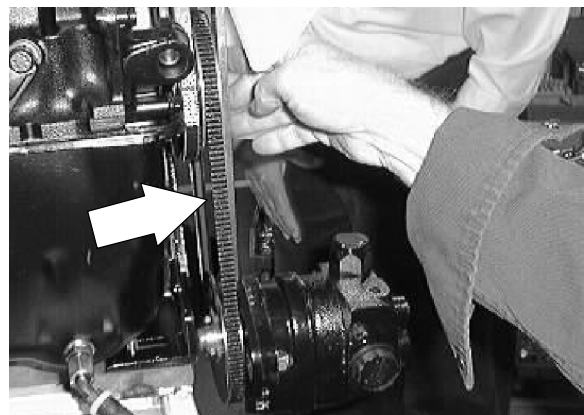

14. The accessory pump belt adjustment is made by turning the bolt on top of the tension spring. The tension spring is located at the front of the engine compartment, near the accessory pump belt sheave. The accessory pump belt is at the proper tension when the tension spring is compressed to 3.81 cm  $\pm$  0.0076 mm (1.5 in  $\pm$  0.030 in).

*NOTE: When adjusting the accessory pump belt tension, measure only the spring and not the washers at either end.*

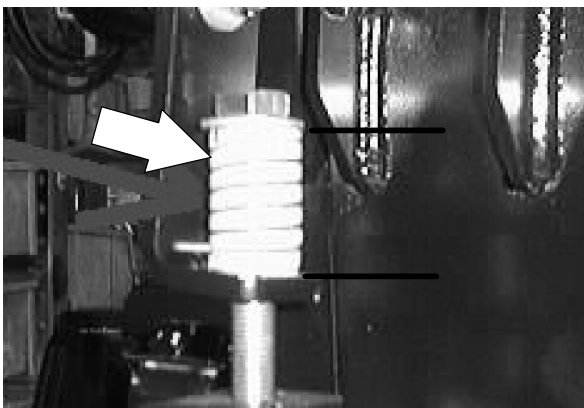

15. Go back and tighten the two pivot plate mount screws to 37 - 48 Nm (26 - 34 ft lb).

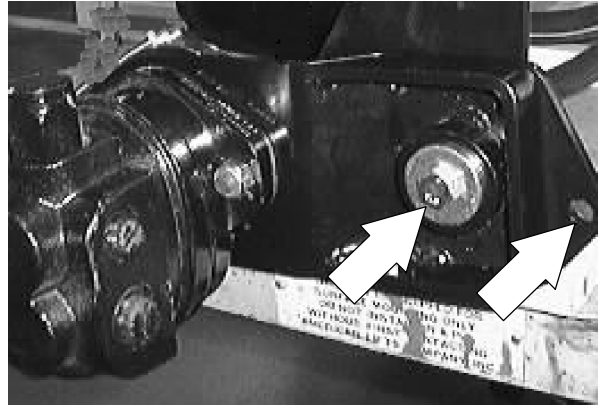

16. Position the rubber dust shield back into the metal bracket.

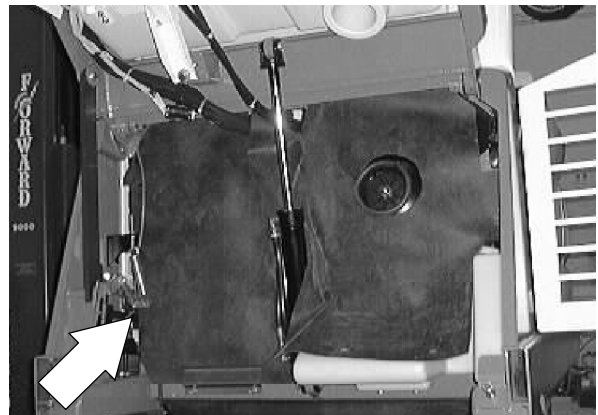

17. Reconnect the battery and start the machine.

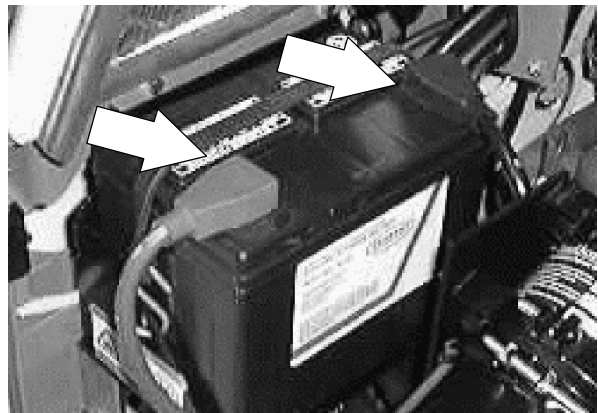

18. Disengage the prop arm and lower the hopper.



19. Check the alternator for proper operation.

## AIR INTAKE SYSTEM

### AIR FILTER

The engine air filter housing has a dust cap and a dry cartridge-type air filter element. Empty the dust cap daily. The air filter must be replaced whenever the filter element is damaged or has been cleaned three times.

Service the air filter element only when the air filter indicator shows restriction in the air intake system. Do not remove the air filter element from the housing unless it is restricting air flow.

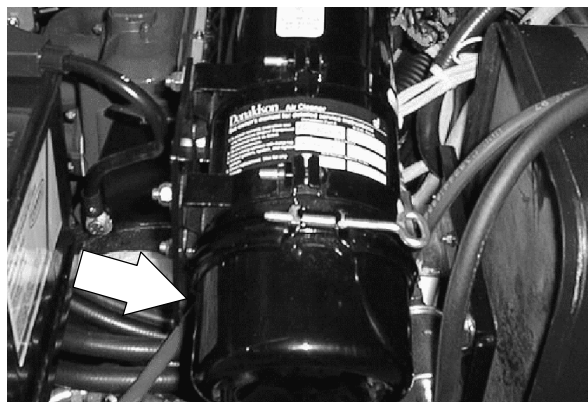

### AIR FILTER INDICATOR (optional)

The air filter indicator shows when to clean or replace the air filter element. Check the indicator daily. The indicator's red line will move as the air filter element fills with dirt. Do not clean or replace the air filter element until the red line reaches 5 kPa (20 in H<sub>2</sub>O) and the "SERVICE WHEN RED" window is filled with red. The indicator's red line may return to a lower reading on the scale when the engine shuts off. The red line will return to a correct reading after the engine runs for a while.

Reset the air filter indicator by pushing the reset button on the end of the indicator after cleaning or replacing the air filter element.





**TO REPLACE AIR FILTER ELEMENT**

**FOR SAFETY: Before Leaving Or Servicing Machine: Stop On Level Surface, Set The Parking Brake, Turn Off Machine And Remove Key.**

1. Open the engine cover and side door.

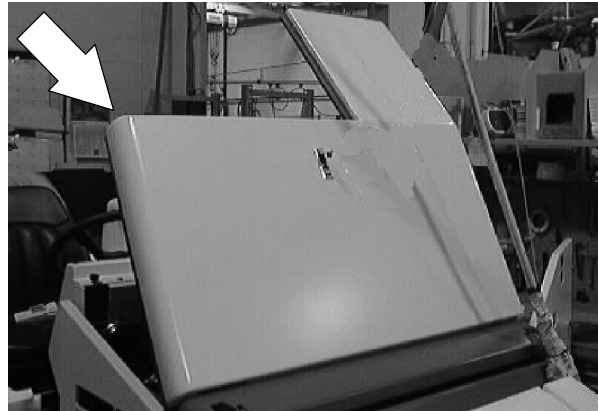

2. Unscrew the clamp ring on the filter.

3. Remove the dust cap.

4. Empty the dust cap.



5. Remove the filter wing nut.

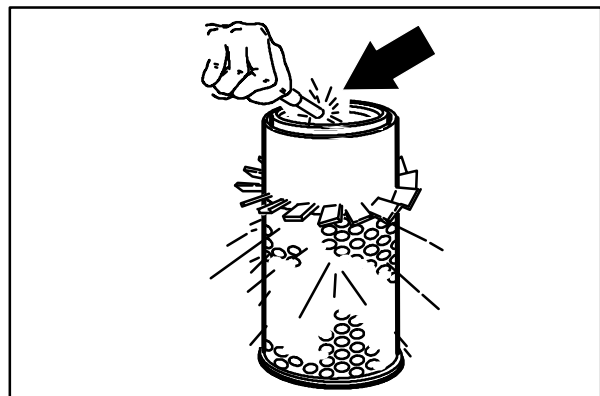

6. Pull the filter element out of the filter housing.
7. Clean the interior of the air cleaner housing with a damp cloth. Clean the element housing sealing surfaces.
8. Using an air hose, direct dry, clean air maximum 205 kPa (30 psi) up and down pleats on the inside of the filter. Do not rap, tap, or pound dust out of the element.

**FOR SAFETY: When Servicing Machine, Wear Eye And Ear Protection When Using Pressurized Air Or Water.**

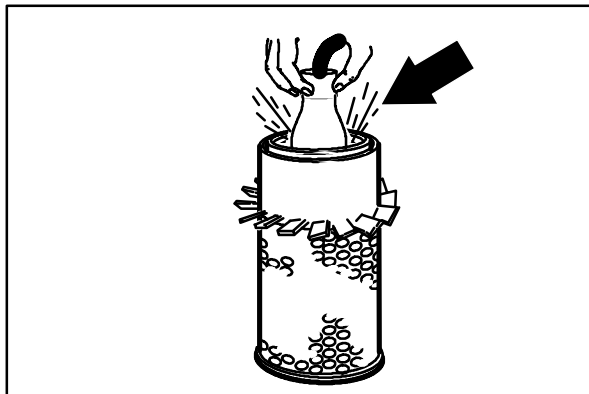

9. After cleaning the air filter element, inspect it for damage by placing a bright light inside. The slightest rupture requires replacement of the filter. Clean and inspect the seals on the ends of the element. They should be unbroken and flexible. Remember to replace the element after cleaning it three times.
10. Install the new or cleaned filter element so the fins on the element are at the intake end of the air cleaner. Be careful not to damage the fins. Make sure the element is seating evenly. Tighten the element wing nut.
11. Install the dust cap with the arrows pointing up. Tighten the clamp ring to hold it in place. Check all intake hose connections for leaks or abrasions.

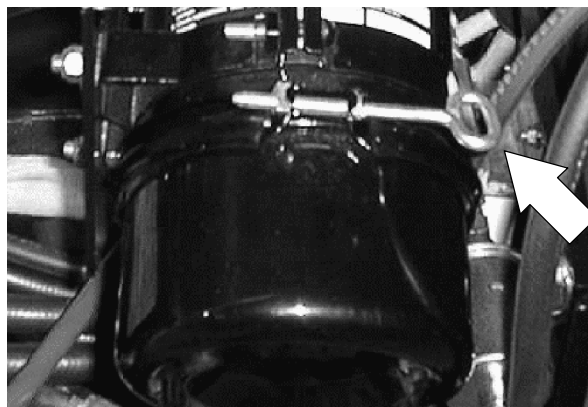

12. Reset the air filter restriction indicator.



13. Close the engine cover and side door.

---

## FUEL SYSTEM - GASOLINE

---

### FUEL FILTER

The fuel filter traps fuel contaminants. The filter is located on the fuel line going into the carburetor.

Replace the filter elements every 400 hours of operation.

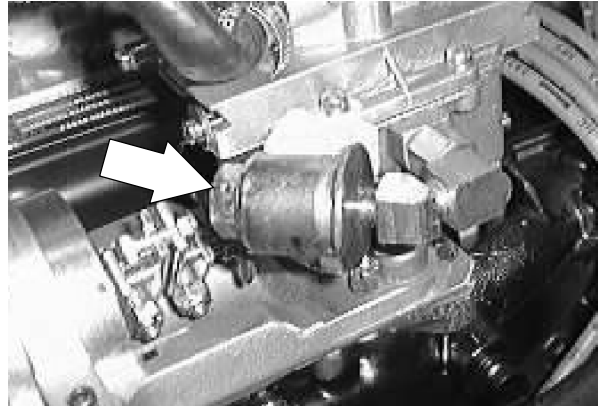

### CARBURETOR

The carburetor has two basic adjustments. Those adjustments are idle fuel mixture and idle speed. Check and adjust idle fuel mixture and idle speed periodically.

The carburetor is designed to deliver the correct fuel-to-air mixture to the engine under all operating conditions. The high idle is set at the factory and cannot be adjusted. The low idle fuel adjusting needle is also set at the factory and normally does not need adjustment.

If the engine is hard-starting or runs roughly or stalls at low idle speed, it may be necessary to adjust or service the carburetor.

**FOR SAFETY: When servicing machine, allow engine to cool. Keep flames and sparks away from fuel system service area. Keep area well ventilated.**

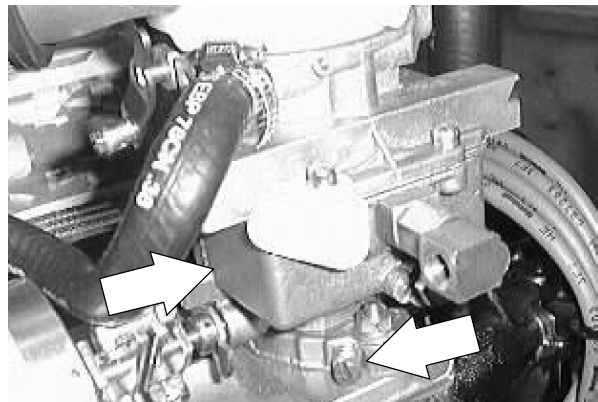

### FUEL PUMP

The in-line fuel pump is located on the mount plate at the end of the fuel tank. The fuel pump is electrically operated with 12 volts from the battery.

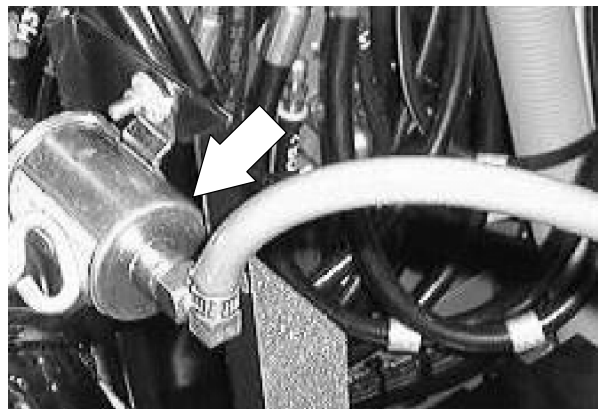

### FUEL SYSTEM - LPG

The liquid withdrawal LPG fuel system has up of five components: the LPG fuel tank, pressure relief valve, fuel filter lock, vaporizer-regulator, and the carburetor.

Liquid LPG fuel flows from the LPG tank under its own pressure, to the pressure relief valve. Usually this valve is closed, preventing LPG fuel from escaping into the atmosphere. The valve opens to relieve pressure if the fuel pressure exceeds system limits. From the pressure relief valve, the liquid LPG fuel flows to the fuel filter lock.

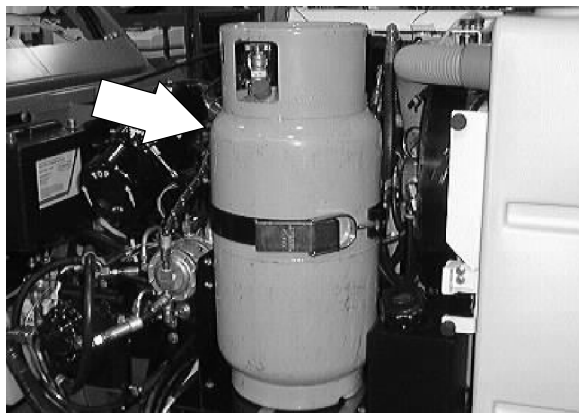

The fuel filter lock filters unwanted tank scale and deposits out of the LPG fuel. The fuel filter lock also stops the flow of LPG fuel when the engine is not operating. The LPG is operated with engine vacuum.

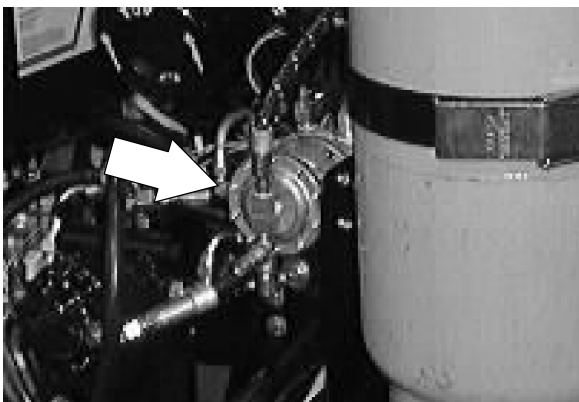

The vaporizer section of the vaporizer-regulator converts the liquid LPG fuel into a gaseous LPG fuel. From the vaporizer section, the gaseous LPG fuel is sent to the primary regulator section of the vaporizer-regulator. The primary regulator section reduces the pressure of the LPG fuel. The secondary regulator section reduces the LPG fuel pressure to the level required by the carburetor. From the vaporizer-regulator, the LPG fuel is sent to the carburetor where it is finally metered into the air flow sent to the engine combustion chamber.

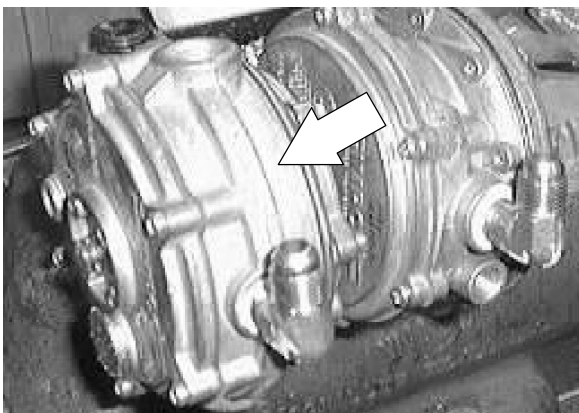

Never operate an LPG powered machine if the LPG fuel system is leaking, or if any component in the fuel system is malfunctioning. Operating the machine under either of these conditions may cause a fire or explosion.

Check for frosting. If frosting occurs on or near any LPG component, there is a possible LPG fuel leak or malfunctioning component.

To locate the leak, apply a soapy water solution to the suspected area. Watch for bubbles forming in this suspected area. This area may have an LPG fuel leak. Repair or replace the part. Use Loctite brand Stainless Steel PST thread sealant when reassembling. Aging or high humidity does not affect this epoxy-type sealant. Be sure to follow application directions and apply proper torque when reconnecting fittings. Never bypass safety components except to test. If they are defective, replace them before operating the machine. Frosting does not occur before the engine reaches operating temperature. Check after engine reaches operating temperature.

Check routings of all LPG hoses. Keep them away from sharp edges, exhaust manifolds, or other hot surfaces. Check for signs of abrasion or deterioration. Replace worn or damaged hoses.

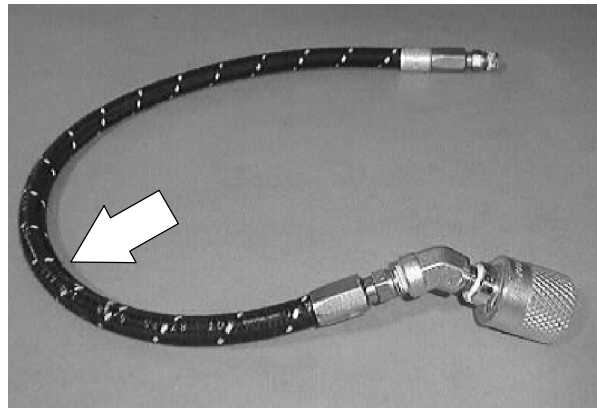

### LP FUEL TANKS

The LPG fuel tanks should be inspected for sharp dents, gouges, leaks, and broken protecting rings whenever the tanks are refilled. All tank valves must be inspected for leaks using a soap solution. Valves must also be checked for dirt, paint, or other debris in the valve openings. The following specific checks must also be made:

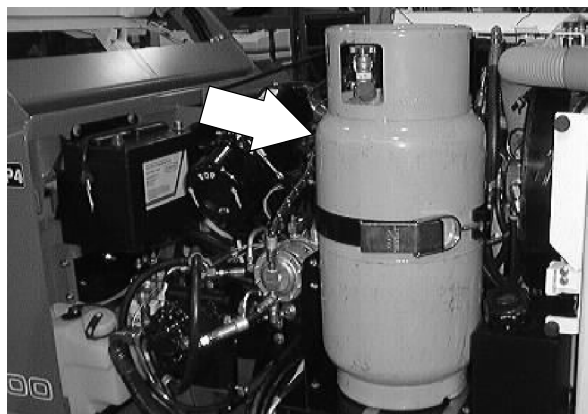

**Filler Valve** - Check the valve for proper functioning and the presence of the handwheel. Valve must be closed except during filling.



**Liquid Service Valves** - Check the valve for proper functioning and presence of the handwheel. The valve must be closed except when in service.



**Tank Service Valve Coupling** - Check for proper functioning, thread condition, and damaged or missing washers or o-rings.



**Safety Relief Valve** - Check for damage. Check for the presence of the relief valve elbow and the proper direction of the elbow. If the rain cap is missing, check for foreign matter and replace the rain cap. Do not tamper with the relief valve setting.

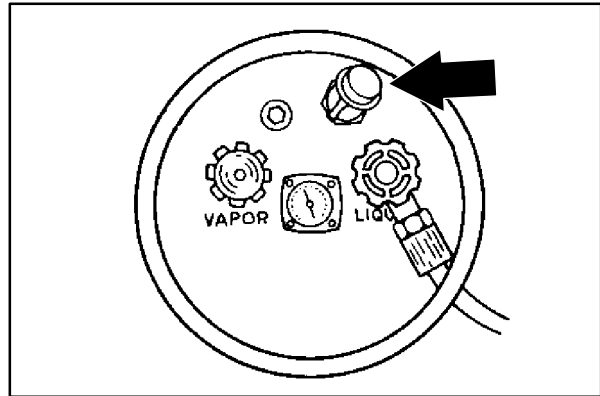

**Magnetic Liquid Level Gauge** - Check the operation against the maximum filling point as determined by weight.



### LPG FUEL TANK STORAGE

An LPG fuel tank with any of the stated defects must be removed from service and be repaired or destroyed accordingly.

If an LPG fuel tank is damaged or leaking, it should be removed to a designated safe area. Do not attempt to make repairs to the tank, regardless of condition. Qualified personnel must make repairs or disposal.

The care an LPG fuel tank receives has a direct bearing on how long that tank can be used safely. LPG fuel tanks must not be dropped or dragged across any surface. To move LPG fuel tanks, use a hand truck or roll the tank on its foot ring while it is being held in a position slightly off the vertical.

Whether the storage is inside or outside, fuel tanks should not be stored near combustible materials or high temperature sources such as ovens and furnaces, since the heat may raise the pressure of the fuel to a point where the safety relief valves would function. Store the tanks in a way that if the safety relief valves do function, they will relieve vapor and not liquid.

Valves on empty tanks must be closed during storage and transportation.

Similar precautions should be taken in storing machines fitted with LPG fuel tanks. The machines may be stored or serviced inside buildings, provided there are no leaks in the fuel system and the tanks are not overfilled. While machines are being repaired inside a building, the shut-off valve on the tank must be closed, except when the engine has to be operated.

Changing the tank is a chance for the machine operator to carefully check over the tank, fittings, and the fuel lines and fittings. If abnormal wear is detected, report the findings to the appropriate personnel.



**TO CHANGE AN LPG FUEL TANK**

1. Park the machine in a designated well ventilated area.
2. Open the engine cover and side door.



3. Close the tank service valve.
4. Operate the engine until it stops from lack of fuel. Set the machine parking brake.

**FOR SAFETY: Before Leaving Or Servicing Machine: Stop On Level Surface, Set The Parking Brake, Turn Off Machine And Remove Key.**



5. Put on gloves and remove the quick-disconnect tank coupling.
6. Inspect the LPG fuel lines for wear or damage.



## ENGINE-GAS/LP

7. Remove the empty LPG fuel tank from the machine.
8. Check the tank for damage or wear.
9. Store the tank in a designated, safe area.
10. Select a filled LPG fuel tank and inspect it for damage or leaks.

*NOTE: Make sure the LPG fuel tank matches the fuel system (liquid tank with liquid system).*

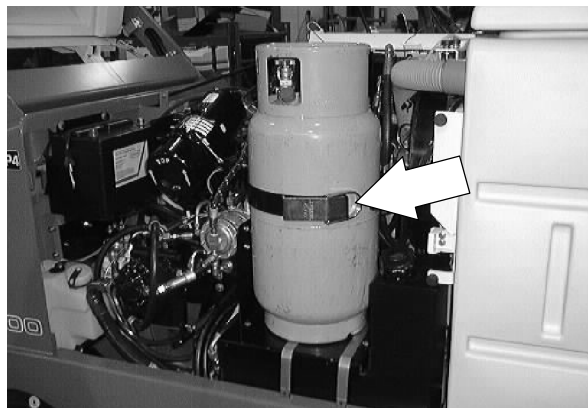

11. Carefully put the LPG tank in the machine so that the tank centering pin enters the aligning hole in the tank collar.

*NOTE: If you cannot line up the centering pin, make sure you have the correct LPG fuel tank and then adjust the pin locator in or out.*

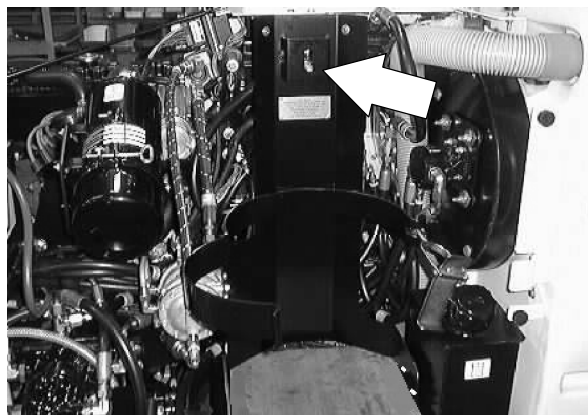

12. Fasten the tank hold-down clamp to lock the tank in position.

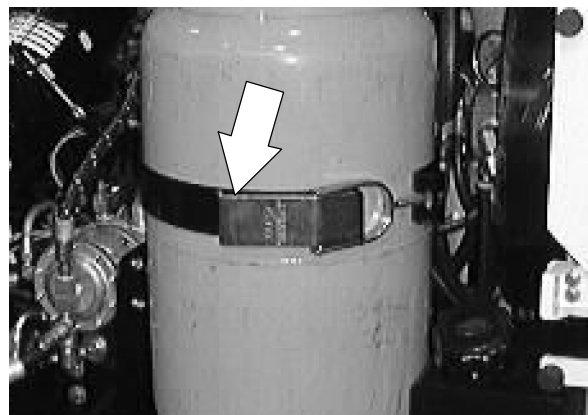

13. Connect the LPG fuel line to the tank service coupling. Make sure the service coupling is clean and free of damage. Also make sure it matches the machine service coupling.

14. Open the tank service valve slowly and check for leaks. Close the service valve immediately if an LPG leak is found, and tell the appropriate personnel.

15. If no leaks are found, the engine is ready to start.

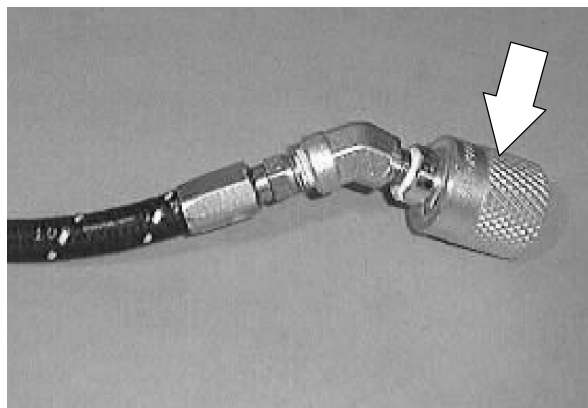

**FUEL FILTER LOCK**

The fuel filter lock filters the LPG fuel. It also stops the flow of LPG fuel to the engine when the engine is not operating.

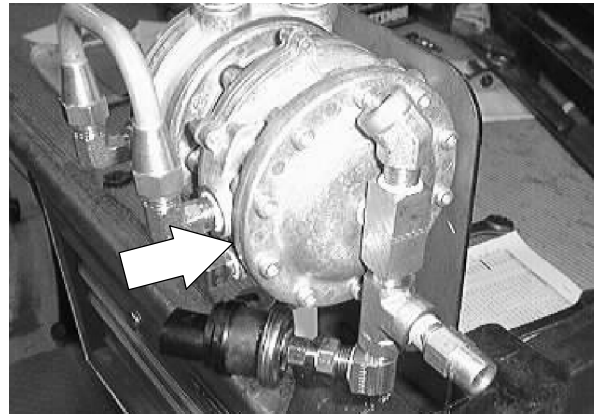
**VAPORIZER-REGULATOR**

If any malfunction is found, completely disassemble the vaporizer-regulator. Clean all the parts in alcohol.

Inspect all the parts and replace where needed. Carefully reassemble the vaporizer-regulator with the seal repair kit. Check for proper operation.

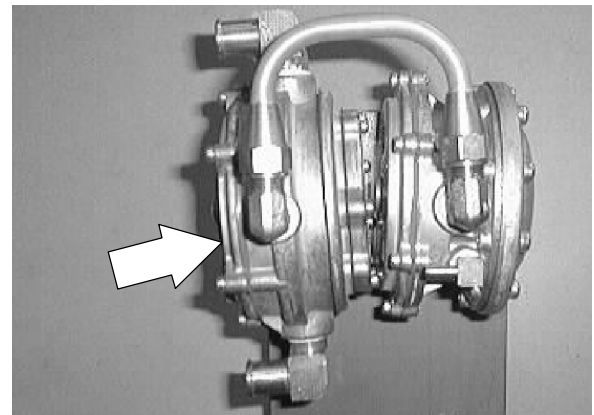
**CARBURETOR**

If any malfunction is found, completely disassemble the carburetor. Clean all the parts in alcohol.

Inspect all the parts and replace where needed. Carefully reassemble the carburetor with the seal repair kit.

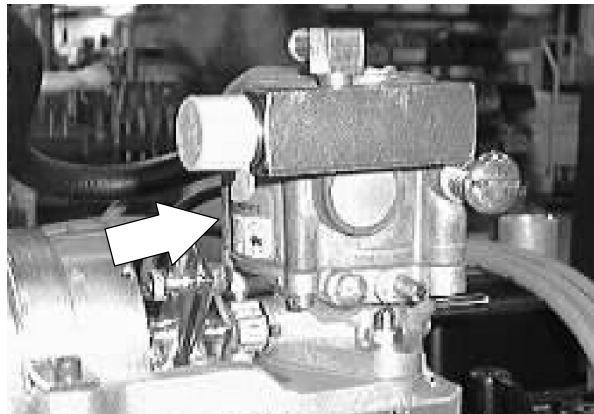
**OIL PRESSURE SWITCH**

The engine oil pressure switch requires no regular maintenance. Never bypass the oil pressure switch. The oil pressure switch turns on the LP lock-off when the engine reaches proper operating oil pressure.

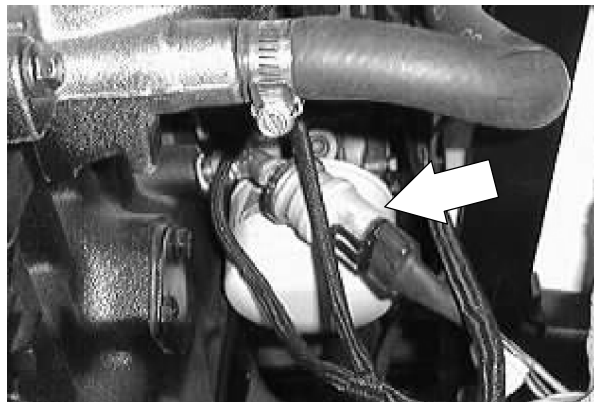

**LPG FUEL TROUBLESHOOTING**

<b>Problem</b>	<b>Cause</b>	<b>Remedy</b>
Engine will not start	Out of fuel	Replace fuel tank with full one
	Service valve opened too quickly - check valve stopped fuel flow	Close service valve and reopen slowly
	Plugged fuel filter	Replace filter
	Kinked or restricted fuel line	Straighten or replace fuel line
	Engine out of tune	Tune-up engine
	Oil pressure switch failure	Replace oil pressure switch
	Fuel lock valve failure	Repair or replace fuel filter lock
	Vaporizer-regulator failure	Repair or replace vaporizer-regulator
Engine runs unevenly or lacks power	Wrong type of fuel tank - vapor withdrawal tank	Replace vapor withdrawal tank with liquid withdrawal tank
	Plugged fuel filter	Replace filter
	Kinked or restricted fuel line	Straighten or replace fuel line
	Engine out of tune	Tune-up engine
	Restricted air filter	Clean or replace air filter element
	Vaporizer-regulator out of adjustment	Adjust vaporizer-regulator

---

**CYLINDER HEAD**

---

A three-stage torque procedure should be used when reassembling the cylinder head. Tighten the cylinder head bolts seasonally. See Ford VSG 411/413 Engine Service Manual.

**VALVE TAPPET CLEARANCE**

Check and adjust the intake valve clearance to 0.22 mm (0.009 in), and the exhaust valve clearance to 0.32 mm (0.013 in) while the engine is cold the first 50 hours of operation and every 400 hours there after. See Ford VSG 411/413 Engine Service Manual.

**CRANKCASE VENTILATION SYSTEM**

Clean the crankcase ventilation hoses, tubes, and fittings and replace the PCV valve every 400 hours of operation.

## GOVERNOR

The electronic governor controls engine speed. The governor consists of an ignition control assembly, a control box, and an actuator mounted on the carburetor. The ignition control assembly and control box regulate the actuator, which in turn controls the throttle.

The carb mounted, electronic governor is factory set and is not user serviceable.

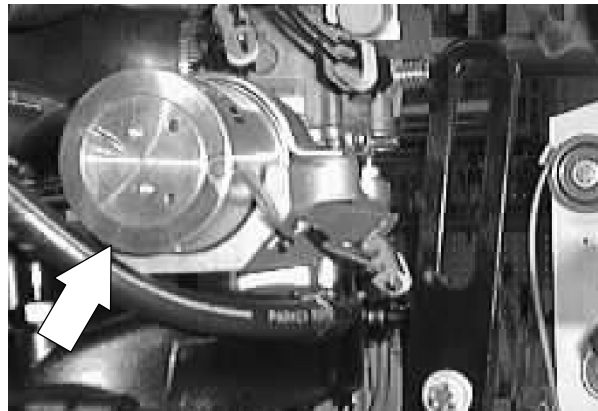

## TO ADJUST GOVERNOR CONTROL BOX

1. Raise the rear of the machine and place jack stands under the frame.

**FOR SAFETY: Block machine tires before jacking machine up. Jack machine up at designated locations only. Block machine up with jack stands.**

2. Start the engine and warm to operating temperature.



3. Move the speed switch to idle, all accessories off.
4. Move the speed switch to the fast position.

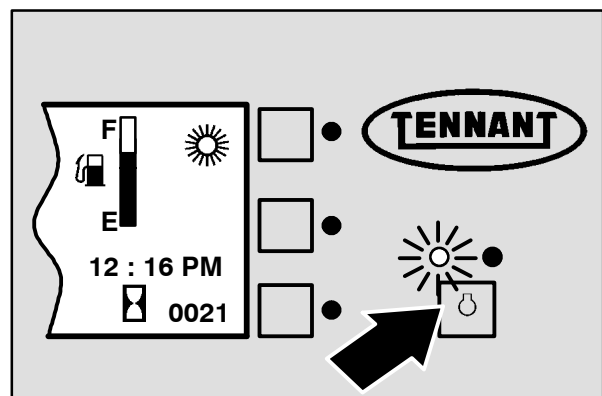

## ENGINE-GAS/LP

5. FOR ANALOG CONTROLLER: If engine speed surges occur, turn the surge adjustment screw (located on back of governor control box under hole plug) counterclockwise one-eighth of a turn.

Repeat until surges do not occur.

Replace hole plug if removed for adjustment.

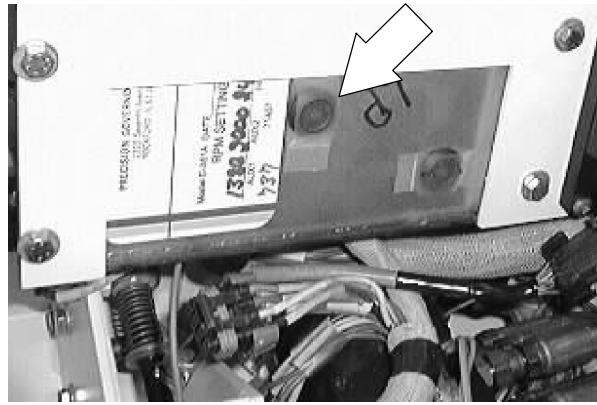

6. FOR DIGITAL CONTROLLER: Follow the instructions on the *DIGITAL CONTROLLER SET-UP* diagram.

7. Remove the jack stands and lower the machine.



Set DIP switches according to controller label, before installing to controller.

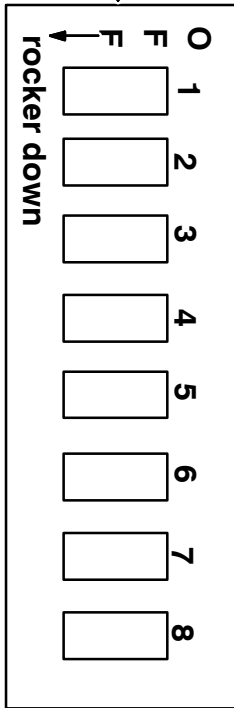

**Digital Controller**  
p/n 374763

Controller Set-Up:		DIP Switch Settings:					
Program Number	Machine Model	Switch number starting from left					
		#1	#2	#3	#4	#5	#6
#1	355/6500/6550/8200/8210/7400 Gas/LP	ON	OFF	OFF	OFF	OFF	OFF
#2	6550/7400/8200/8210 Diesel w/ SJ actuator (linear)	OFF	ON	OFF	OFF	OFF	OFF
#3	355/6500/6550/7400 Diesel w/ SF (rotary) actuator	ON	ON	OFF	OFF	OFF	OFF
#4	800/810 Gas	OFF	OFF	ON	OFF	OFF	OFF
#5	800/810 LP	ON	OFF	ON	OFF	OFF	OFF
#6	800/810 550/1550 Diesel	OFF	ON	ON	OFF	OFF	OFF
#7	8400/8410 Gas	ON	ON	ON	OFF	OFF	OFF
#8	8400/8410 LP	OFF	OFF	OFF	ON	OFF	OFF
#9	8400/8410 Diesel	ON	OFF	OFF	ON	OFF	OFF
#10	6500II LP / Gas	ON	ON	OFF	ON	OFF	OFF
#11	6500II/6550II Diesel	OFF	OFF	ON	ON	OFF	OFF
#12	800/810 Diesel – 2 spd	ON	OFF	ON	ON	OFF	OFF
#13	800/810 Gas - 2 spd	OFF	ON	ON	ON	OFF	OFF
#14	800/810 LP – 2 spd	ON	ON	ON	ON	OFF	OFF
#15	355/6500/6550/8200/8210/7400 Gas/LP – special 2 spd	OFF	OFF	OFF	OFF	ON	OFF
#16	6550/7400/8200/8210 Diesel w/ SJ actuator (linear) sp. 2 spd	ON	OFF	OFF	OFF	ON	OFF
Special DIP Settings: ↓		Special DIP Settings: ↓					
Engines with Distributor		Altitude compensation					
#7		#8 RPM added					
ON	Distributor	ON 200 rpm					
OFF	Non Distributor (DIS)	OFF 0 rpm					

Gain pot and Trouble shooting LED can be seen through here:  
←

**DIGITAL CONTROLLER SET-UP**

## GOVERNOR TROUBLESHOOTING

1. The first step in this troubleshooting is to disconnect the throttle linkage at the carburetor and work the throttle at the carburetor by hand.

If you can run the engine by hand and it works with no problems, go to step four.

If the problem continues, it is not with the governor, it is with the ignition signal fuel systems or the engine itself.

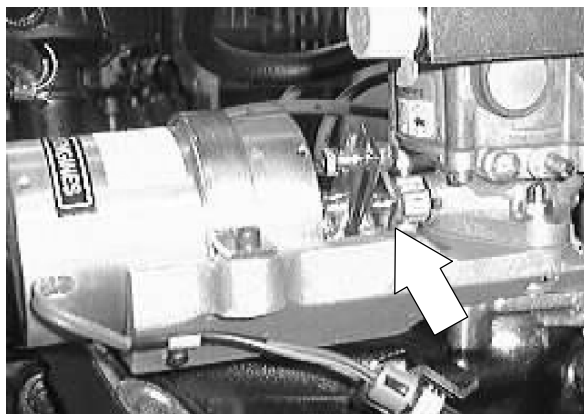

### 2. Ignition Signal

The DIS engine has no distributor, but the timing signals that drive the governor originate from the Ignition Control input leads. They are the Yellow Wire #71 and the Yellow Wire #72. To test this, use the governor test harness (TENNANT Part No. 66137). Once the harness is in place, use a tach/dwell meter to test for the proper RPM's and a flat ignition signal. Test at the test plug at either Pin C, or Pin D.

*NOTE: An inductive RPM pickup won't work for this test.*

*NOTE: When checking the RPM's at Pin C, and Pin D, the ignition signal will be half of the total RPM's the engine is running at because of the DIS system.*

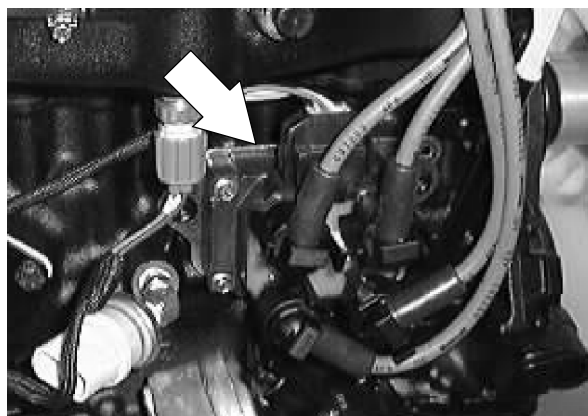

Your readings should be:

#### TOTAL READING-GAS

- a. Start/Idle - 800 RPM
- b. I -  $1350 \pm 50$  RPM
- c. II -  $2400 \pm 50$  RPM

#### TOTAL READING-LPG

- a. Start/Idle - 900 RPM
- b. I -  $1350 \pm 50$  RPM
- c. II -  $2400 \pm 50$  RPM



### 3. Fuel System

A common problem that has been encountered on LPG machines is a restricted fuel hose (a clogged fuel filter can have the same effect).

If the governor opens the carburetor wide open and the engine loses speed, the problem is not in the governor. The purpose of the governor is to open the carburetor and to bring the engine to set RPM's depending on where you have the speed control switch set at.

After you have verified that the ignition system and the fuel system are not at fault, go to the next step.

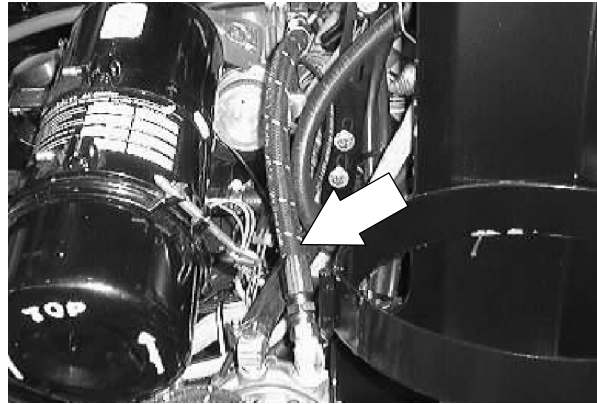

### 4. System Grounds

The wire harness grounds on the machines with a DIS engine are routed to the stud on the alternator, and from there, a separate cable is routed to the bolt on the bell housing where the battery cable is attached.

If a bad ground is present, the engine will tend to run over speed.

The machine must have good grounds throughout from the battery cable to the control box.

The battery cable must be clean and tight.

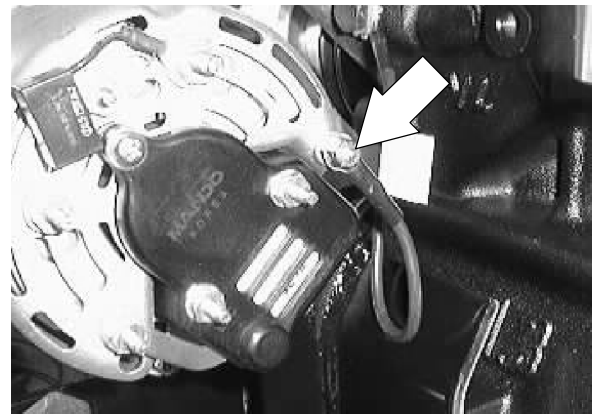

There must not be a greater voltage drop than .2 volts between Pin B, on the test harness, the engine, the alternator, and the battery positive terminal and the battery negative terminal.

To do this, take your voltmeter and set it on the DC volts scale. Then with your positive probe, clamp it to battery positive. Then with the negative probe, move it to the above-stated places on the machine.

The actuator is internally isolated and does not require that the cable be grounded.

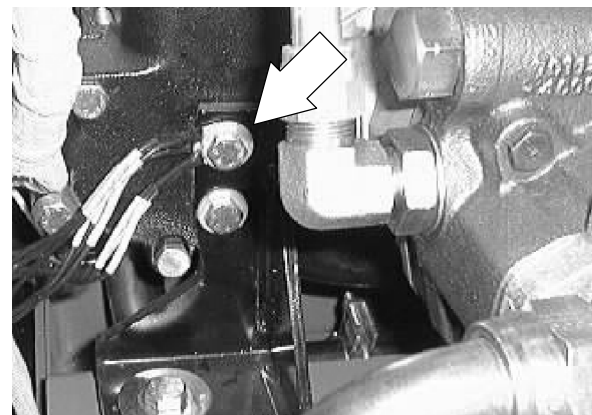

### 5. Start-Up Check

With the throttle switch in the engine start position, turn the ignition switch to the on position. The actuator should cycle the carburetor lever once.

*NOTE: A cycle is to move from the off or idle position to the open position and then return to the off or idle position.*

If this does not happen, the power wiring to the control box is probably at fault or the control box is faulty. **IT IS RARE TO HAVE A FAULTY CONTROL BOX**, so proceed with the following voltage checks **BEFORE REPLACING IT**.

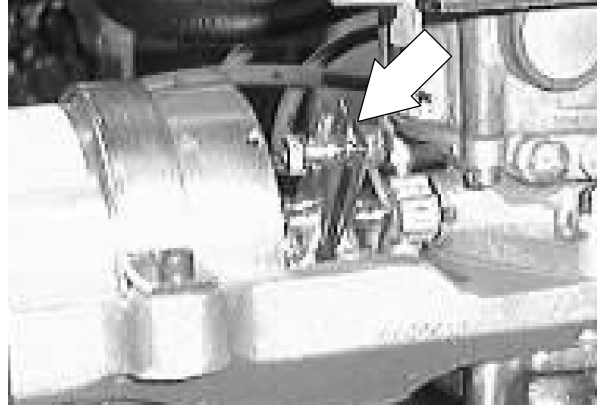

### 6. Throttle Control Switch Check

If the engine doesn't respond to the throttle switch control:

- a. With the engine running, disconnect Wire 86, purple wire, at the actuator.
- b. Connect a jumper wire from the battery terminal on the starter to the terminal where you removed Wire 86, purple wire, from the actuator.

The engine should come up to operating speed. If the engine comes up to speed, replace the throttle control switch. If the engine doesn't respond, go to the next step.

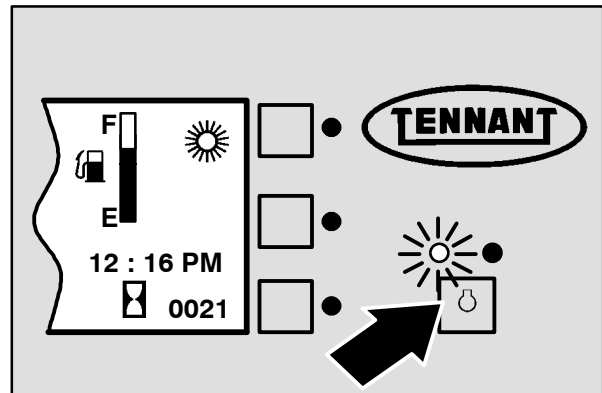

### 7. Operating Voltage

The following voltage checks are done with the machine not running and using a Fluke or Beckman digital multimeter and the governor test harness.

Throttle control switch in start/idle position:

Pin A - Battery Voltage  $\pm .2$

Pin B - 0 - this is a ground

Pin C - Battery Voltage  $\pm .2$

Pin D - Battery Voltage  $\pm .2$

Pin E - Battery Voltage  $\pm .2$

Pin F - Battery Voltage  $\pm .2$

Pin G - Battery Voltage  $\pm .2$

Pin H - 3 to 3.5 VDC

Throttle control switch in the normal sweep position:

Pin G - < 1 VDC

Pin H - 7 to 9 VDC

Throttle control switch in the Litter sweep position:

Pin G - < 1 VDC

Pin H - < 1 VDC

The following voltage and RPM readings are at the electric control box using the test harness with the machine running.

*NOTE: when you are testing if you should be in the DC or AC scale on your multimeter. You will also need your tach/dwell for the RPM checks.*

The readings are taken with either a Fluke or Beckman digital multimeter:

Throttle control switch in the start/idle position:

Pin C - 675  $\pm$  100 RPM

Pin D - 675  $\pm$  100 RPM

Pin E - Battery Voltage  $\pm .2$

Pin F - 6 to 6.5 VAC

Throttle control switch in the normal sweep position:

Pin C -  $1100 \pm 25$  RPM

Pin D -  $1100 \pm 25$  RPM

Pin E - Battery Voltage  $\pm .2$

Pin F - 6.5 to 7 VAC

Throttle control switch in the litter sweep position:

Pin C -  $1200 \pm 25$  RPM

Pin D -  $1200 \pm 25$  RPM

Pin E - Battery Voltage  $\pm .2$

Pin F - 7 to 7.5 VAC

If you do not get these values:

Pin A - Check battery, wiring/connections, and also the charging system.

Pin B - Check all grounds.

Pin C - Check ignition system and fuel systems.

Pin D - Check ignition system and fuel systems.

Pin E - Possible control board.

Pin F - Possible control board.

Pin G - Possible switch.

Pin F - Possible switch.

The volt readings at the actuator with the machine running and using a Fluke or Beckman digital multimeter:

At the terminal where Wire 84, green wire, is hooked to:

Start/Idle - 6 to 6.5 VAC  $\pm .2$

Normal - 6.5 to 7 VAC  $\pm .2$

Litter - 7 to 7.5 VAC  $\pm .2$

At the terminal where Wire 86, purple wire, is hooked to:

Start/Idle - 12 to 14.5 VDC  $\pm$  .2

Normal - 12 to 14.5 VDC  $\pm$  .2

Litter - 12 to 14.5 VDC  $\pm$  .2

## 8. Control Box Adjustment

If all the above aspects, in particular the linkage, have been verified and the warmed up engine either:

- a. Hunts at running speed with the accessories off.
- b. Responds very sluggishly to switch changes, an adjustment change in the control box may be necessary.



### FOR ANALOG CONTROLLER:

Remove the plastic seal plug from the back of the box.

A slight adjustment of the surge screw may be necessary to correct the conditions mentioned above. Turn the screw approximately  $2^\circ$  at a time and wait for 30 seconds to verify the change. Be careful. Only a slight change is necessary, and the "pot" can be broken if too much force is used.

After the control throttle response is achieved, verify that the operating speeds are correct and adjust, if necessary. After the speeds are reset, the surge screw may have to be readjusted.

In general, if a new box is being installed, a gasoline-equipped machine may require that the sensitivity be reduced slightly.

When the sensitivity is adjusted, the run speed should not be affected. If the adjustment is too great, the start speed will be affected. Verify that the start speed is correct.

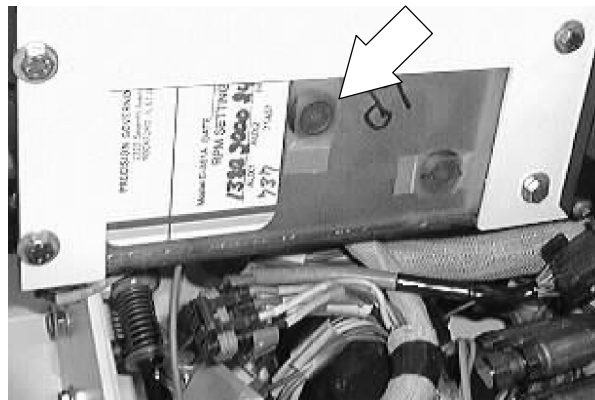

## ENGINE-GAS/LP

---

If too much sensitivity is adjusted in, the engine will either hunt in a no load condition or over speed severely when the speed switch is actuated.

If too little sensitivity is adjusted in, the engine will seem sluggish. The engine speed will drop off when the load is increased and not recover promptly.

The engine speed should not drop off, but you can have the three hunts of the engine.

If, for some reason, the sensitivity adjustment became grossly maladjusted, a good starting point can be obtained by rotating the pot fully counterclockwise and then back clockwise 45°.

After the adjustments are made and verified, reinstall the plastic plug into the back of the governor box.

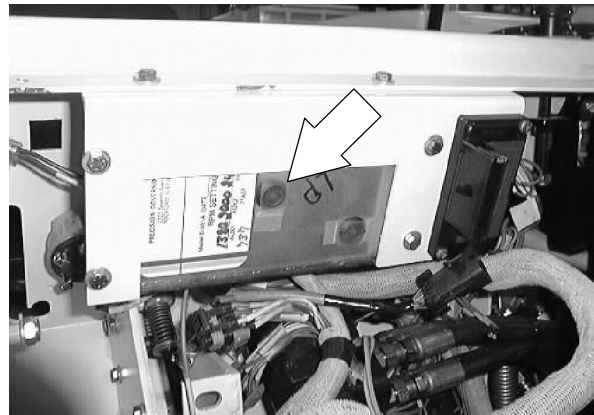

### FOR DIGITAL CONTROLLER:

See *TO ADJUST GOVERNOR CONTROL BOX* section of this manual.

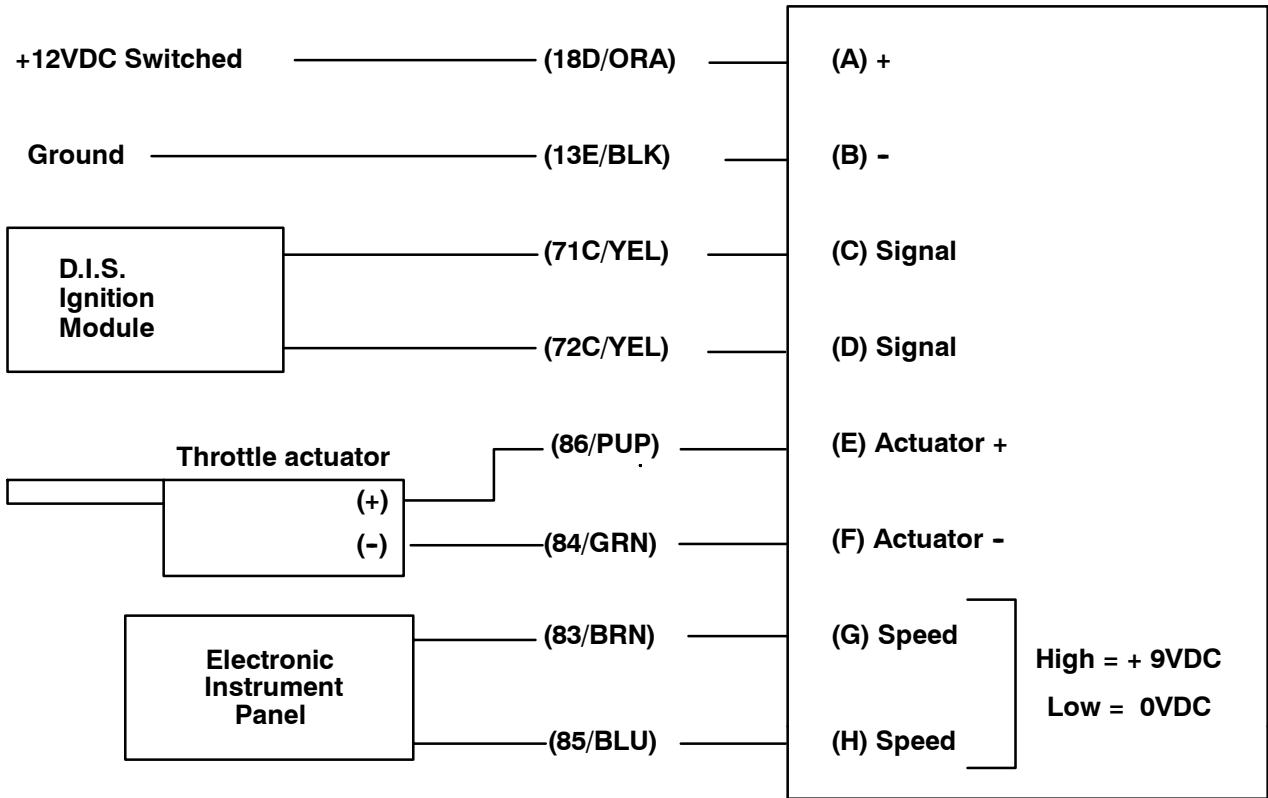

**ELECTRONIC GOVERNOR WIRING PICTORIAL**

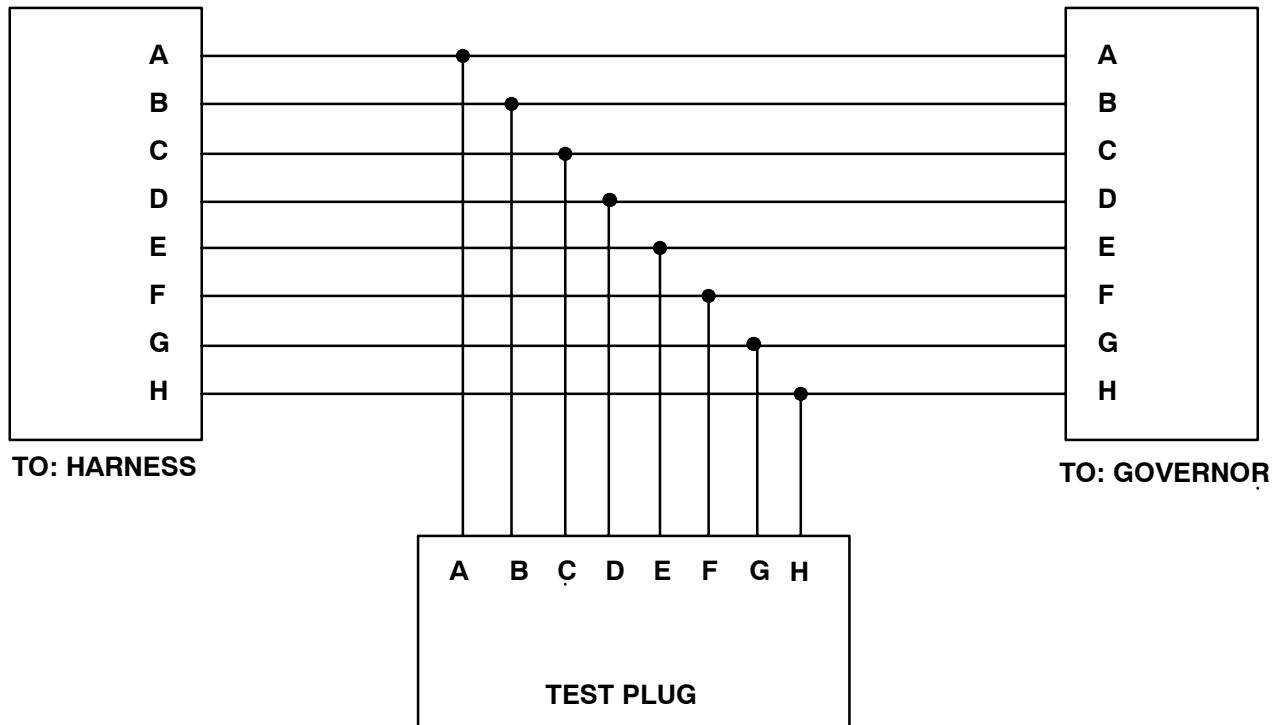

*NOTE: The wire colors of the test harness do not necessarily match the machine harness.*

## IGNITION SYSTEM

### SPARK PLUGS

Clean or replace, and set the gap of the spark plugs every 400 hours of operation. A wire gauge is best for checking the spark plug gap. A flat gauge should not be used unless the electrode surfaces have been dressed with a small file to get parallel surfaces between the center and side electrode. Set the spark plug gap by bending the side electrode. All spark plugs, new or used, should have the gaps checked and reset if necessary.

The proper spark plug gap is 1 mm (0.040 in).

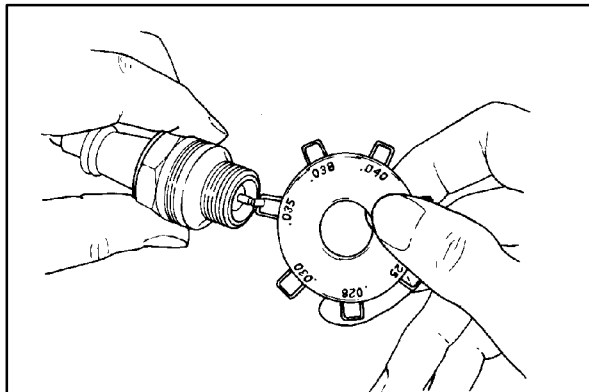

### TO REPLACE SPARK PLUGS

**FOR SAFETY: Before Leaving Or Servicing Machine: Stop On Level Surface, Set The Parking Brake, Turn Off Machine And Remove Key.**

1. Open the engine cover and side door.



2. Remove the spark plug wires from the spark plugs.

*NOTE: Clean any dirt from the spark plug seat area before removing the spark plugs.*

3. Remove the spark plugs from the engine.
4. Clean the spark plug seat in the cylinder head. Use a new seat gasket and screw the new spark plug in by hand.
5. Tighten the spark plugs with a socket wrench of the correct size. Reinstall the spark plug wires.
6. Close the engine cover and side door. Start the engine. Check for proper operation.

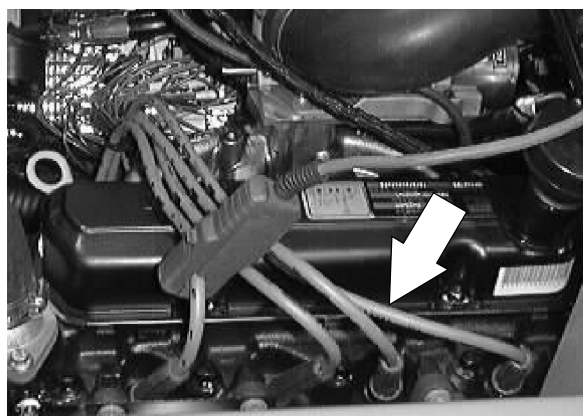



---

**FORD DISTRIBUTORLESS IGNITION SYSTEM**

---

**SYNOPSIS:**

This is a troubleshooting guide for the Ford Distributorless Ignition System.

Unlike a conventional system, the Ford Distributorless Ignition System (DIS) uses two coils that each fire one pair of spark plugs. The spark plugs are also fired on both the power and exhaust stroke.

The DIS system also uses a Universal Electronic Spark Control (UESC) module which adjusts the timing of the engine. The degree of timing change needed is determined by electrical and vacuum input to the UESC, these are:

The engine wire harness has a separate wire for the gas and another for the LPG machines. Make sure you connect the correct wire for the type of fuel being used.

**Engine Load - From Pressure Reducer**

Located in the intake manifold

Minimum 21 KPA (6.22" Hg)

Maximum 101 KPA (29.91" Hg)

**Engine Temperature**

The Engine Coolant Temperature Sensor (ECTS) located in the intake manifold water jacket sends engine temperature information to UESC.

Minimum -39° C 38° F

Maximum 112° C 232° F

When the engine is starting, at 250 RPM or less, the timing is set at 10° before top dead center (BTDC).

### RUN MODE

In this mode the RPM is above 250 and the spark advance is calculated in three sections which are added together to maintain optimum running condition.

The Base Spark Advance (BSA) is calculated by the UESC module looking at speed and load inputs.

The Spark Advance Offset Temperature (SAOT) will change ignition timing. This is determined by the Engine Coolant Temperature (ECT). This allows the spark advance to be altered during cold engine conditions.

### SERVICING AND TESTING

#### Servicing

1. Every 400 hours, remove the spark plugs and clean and adjust the electrode.
2. Clean and visually check spark plug high tension leads and test for resistance. The Ohm meter should read between 9,000 and 16,000 Ohms.

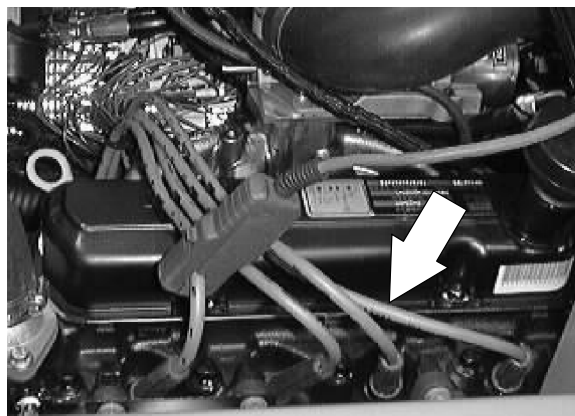

#### Testing

##### Secondary Coil Testing

Remove the four (4) spark plug wires and measure the secondary coil resistance by placing the meter into plug wire terminal.

1 - 4 at the coil

2 - 3 at the coil

On each test you should read  $14,000 \pm 50$  Ohms.

##### Universal Spark Control Module Diaphragm Testing

Using a vacuum pump, apply 15" Hg to the UESC and vacuum inlet. The diaphragm should hold the pressure. If it fails, replace UESC unit.

To test the sensors and wiring harness, follow the direction on the next three pages.

**“FAILURE MODE OF DIS” IGNITION HARNESS**

The Ford DIS Universal Spark Control was checked for “poor connection”.

The results of open leads were:

Term 11 or 12 Ignition Coil Signal Leads - The governor received 1/2 of its intended signal and caused the actuator to hold the carb arm wide open. At the same time, the engine missed due to incorrect firing of plugs, but the speed still climbed to about 3,000-4,000 rpm. When either of these leads were opened at the start speed, the engine missed slightly and rose to double the start speed or about 3,000 rpm.

Term 9 Ground - Any failure here killed the engine instantly or caused the engine to slow down if it were cycled.

Term 6 & 7 Octane Selector - Opening these terminals retards the spark in varying degrees. Under light to moderate load conditions, no adverse effect will take place. However, run-on or pre-ignition may take place.

Term 4 & 10 Coolant Sensor - Contrary to previous thoughts, opening the lead doesn't noticeably affect the engine. The timing only changes a few degrees.

Term 2 & 3 Crank Position Sensor - Opening either of these leads kills the engine quickly and it will not start.

Term 8 Power Lead - Opening this lead kills the engine and it will not start.

In summary, no alarming effect happens except if the coil signal leads are interrupted. These are the end leads on the module and if the harness has too much tension on it, the signal will become intermittent and cause the engine to overspeed. The only obvious damage will probably occur to the propelling pump, as the fan is rated for operation to 10,000 rpm. If the acc. are on when the lead becomes intermittent, the engine will not develop enough power to overspeed excessively.

# ENGINE-GAS/LP

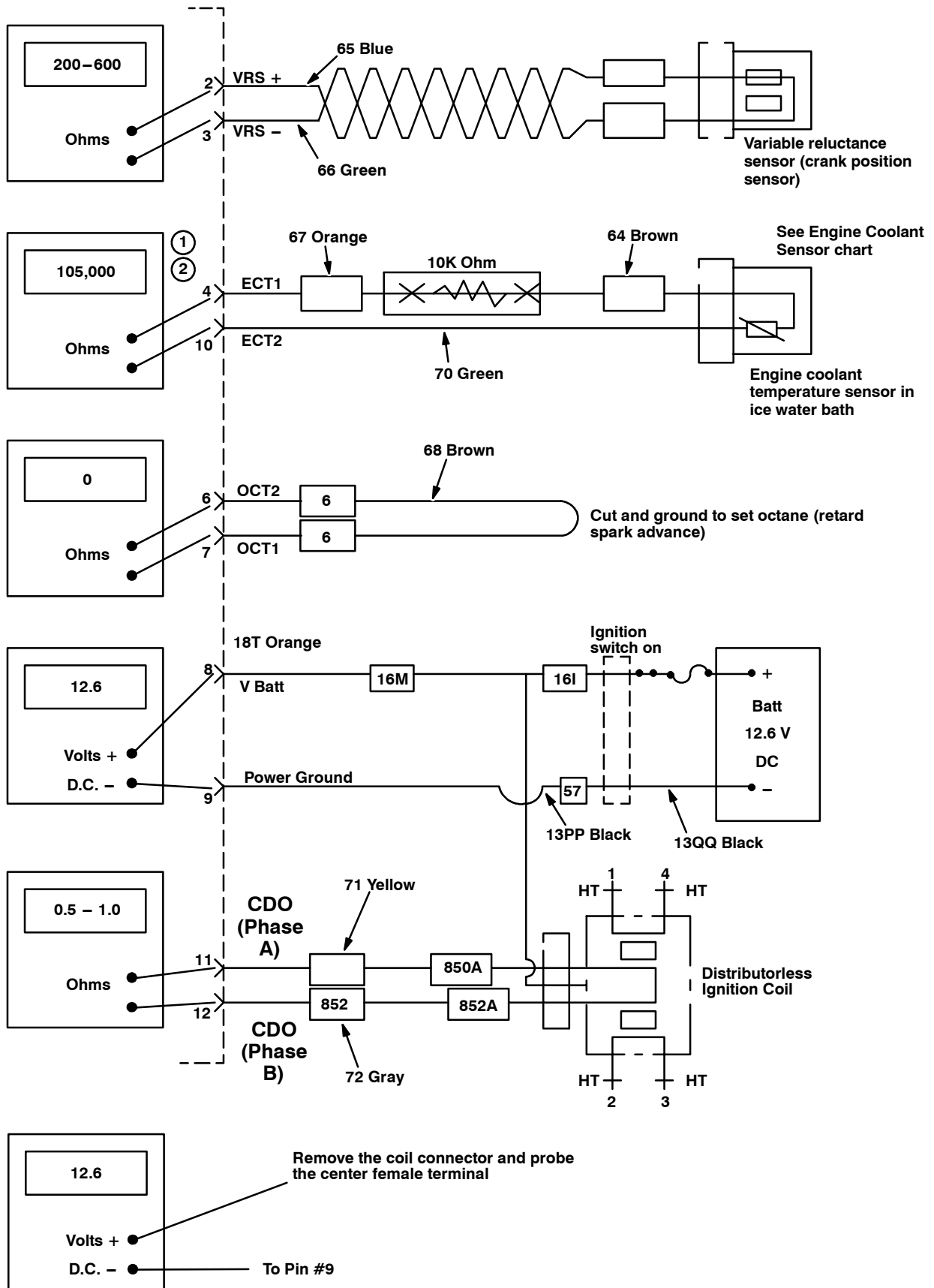

## FORD DIS IGNITION

## Engine Cooler Sensor

Temperature ° C ° F		Sensor (Ohms) ± .02°	Sensor & Harness (Ohms) ± .03°
-30	-22	481,000	491,000
-20	4	271,000	281,000
-10	14	158,000	168,000
0	32	95,000	105,000
10	50	58,750	68,750
20	68	37,300	47,300
30	86	24,270	34,270
40	104	16,150	26,150
50	122	10,970	20,970
60	140	7,600	17,600
70	158	5,360	15,360
80	176	3,840	13,840
90	194	2,800	12,800
100	212	2,070	12,070
110	230	1,550	11,550
120	248	1,180	11,180
130	266	930	10,930
140	284	701	10,701
150	302	550	10,550

### TO REPLACE ALTERNATOR

1. Raise the hopper and engage the prop bar.

**⚠ WARNING: Raised Hopper May Fall. Engage Hopper Support Bar.**

**FOR SAFETY: Before Leaving Or Servicing Machine; Stop On Level Surface, Set Parking Brake, Turn Off Machine And Remove Key.**

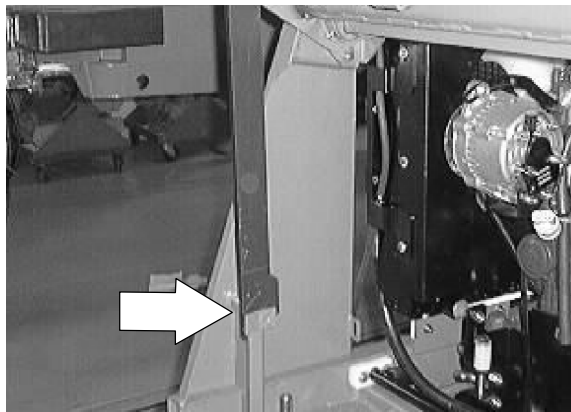

2. Open the engine cover and side door.

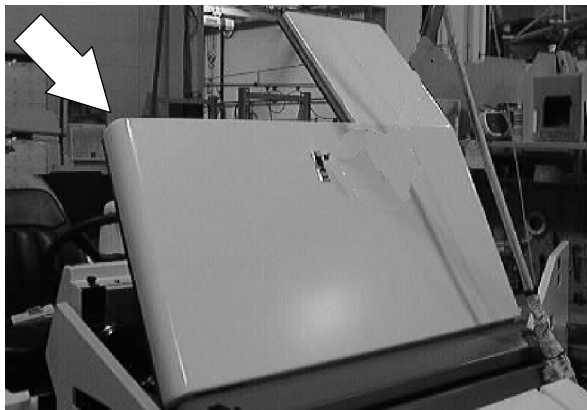

3. Disconnect the battery cables from the battery.

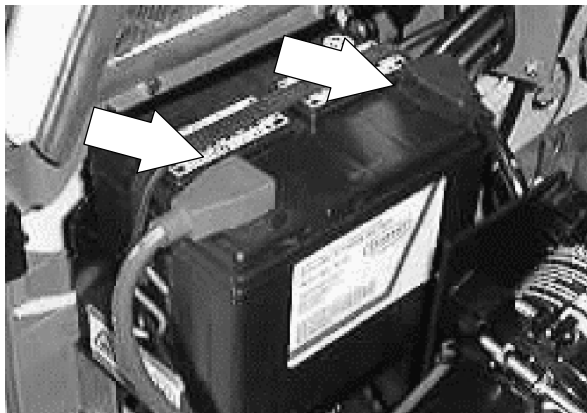

4. Pull the rubber dust shield away from the front of the engine in the area of the alternator.

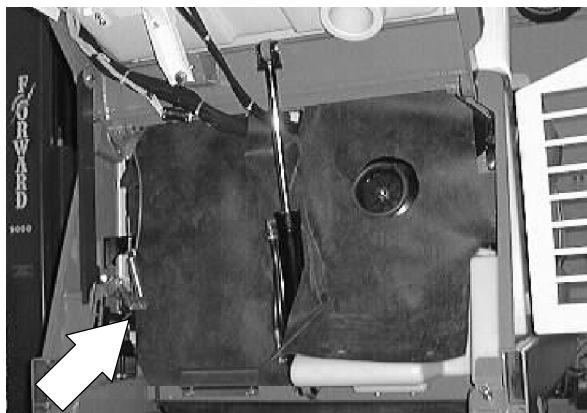

5. Cut any plastic wire ties holding the wire harness to the alternator bracket.

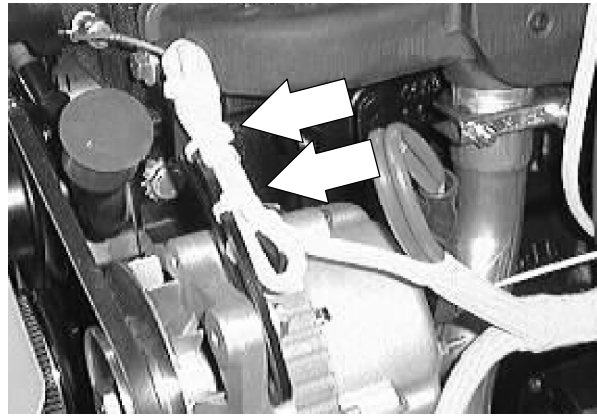

6. Remove the hex screw holding the top of the alternator to the mount bracket. Remove and retain the heat shield.

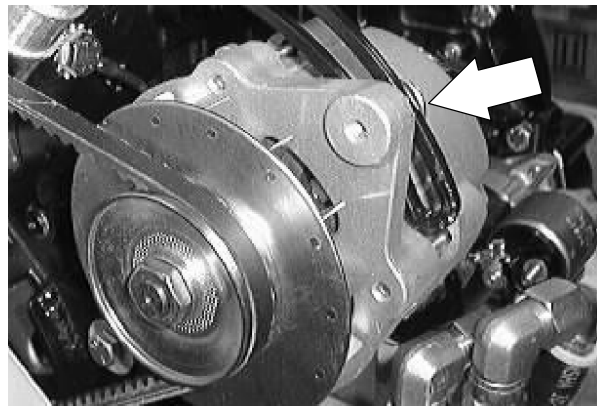

7. Push the alternator in toward the engine and remove the V-belt.

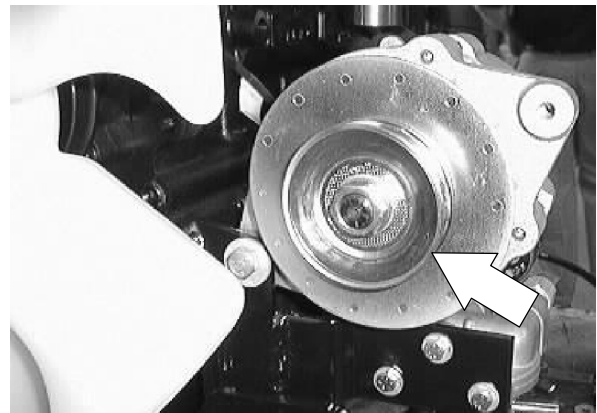

8. Disconnect the wires leading to the back of the alternator.

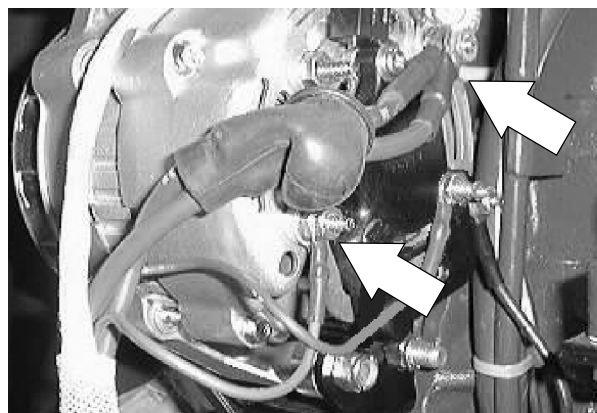

## ENGINE-GAS/LP

9. Remove the hex screw and nyloc nut holding the bottom of the alternator to the lower mount bracket.
10. The alternator can now be removed out the front of the machine.

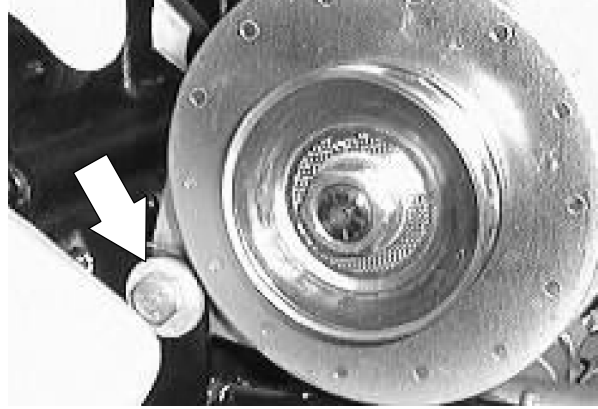

11. If the new or rebuilt alternator needs a drive pulley, remove the pulley from the old alternator. Hold the pulley from turning and use an impact wrench to remove the hex nut.



12. Install the pulley, washer, and hex nut on the new alternator. Firmly tighten the nut with the impact.

13. Install the new alternator back in the machine. Align the bottom hole in the alternator with hole in lower mount bracket. Reinstall the hex bolt, ground cable, and nyloc nut. Leave it loose for now.



14. Reconnect the wires to the back of alternator. See the schematic in the ELECTRICAL section.

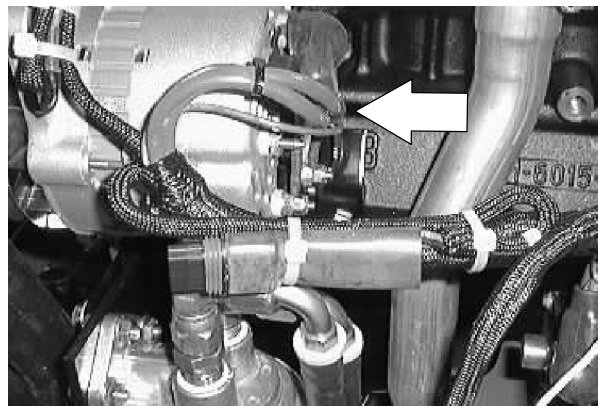



15. Place the V-belt back on the alternator pulley.

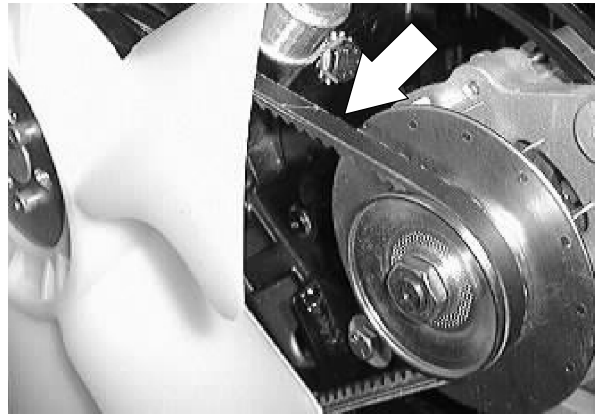

16. Reinstall the hex screw in the top hole of the alternator through upper slotted mounting bracket. Pull the alternator away from the engine to tighten the belt. See adjustment in ENGINE FAN BELT description. Tighten the hex screw to 18 - 24 Nm (13 - 18 ft lb).

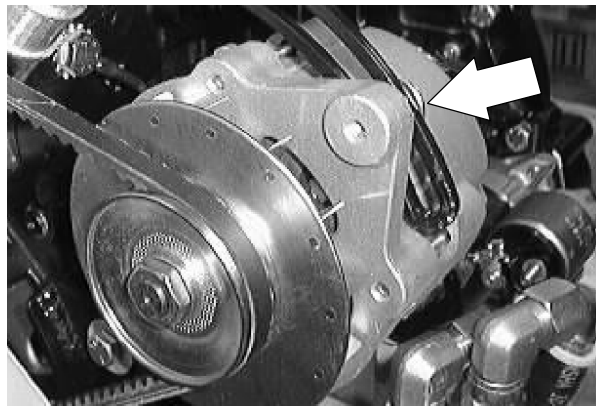

17. Tighten the bottom hex screw to 18 - 24 Nm (15 - 20 ft lb).

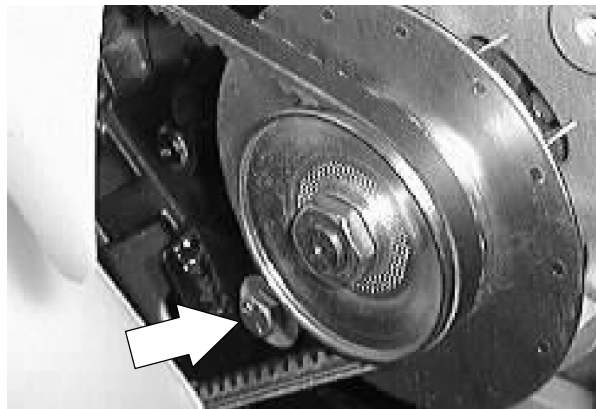

18. Place the rubber dust shield back in position.

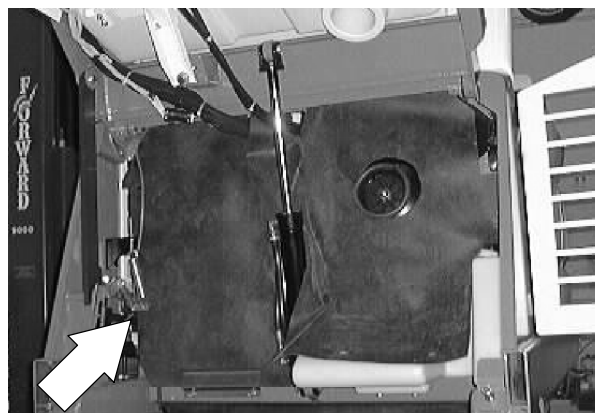

19. Reconnect the battery cables and start the engine. Check the new alternator for proper operation.

### TO REPLACE STARTER

1. Raise the hopper and engage the prop bar.

**⚠ WARNING: Raised Hopper May Fall. Engage Hopper Support Bar.**

*NOTE: If the engine will not start because of a bad starter--use an overhead crane to lift the hopper and engage the prop arm.*

**FOR SAFETY: Before Leaving Or Servicing Machine; Stop On Level Surface, Set Parking Brake, Turn Off Machine And Remove Key.**

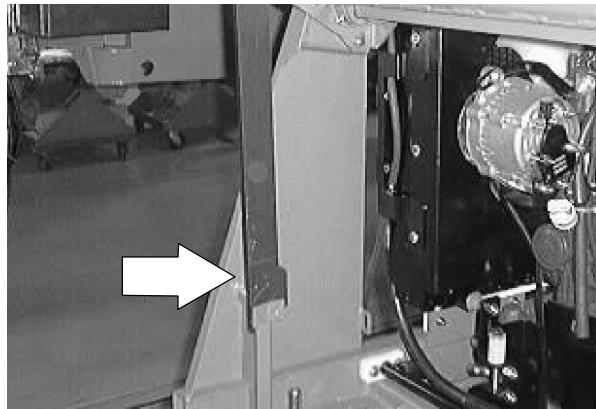

2. Open the engine cover and side door.



3. Disconnect the battery cables from the battery.

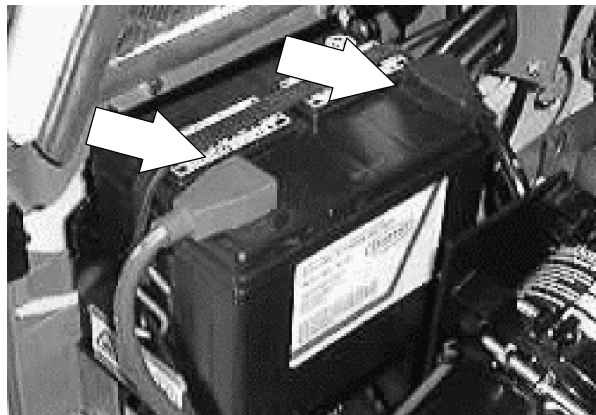

4. Pull the rubber dust shield away from the front of the engine in the area of the starter.

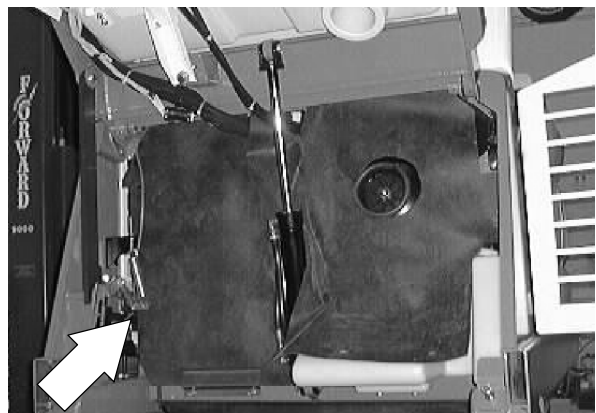

5. Mark, disconnect, and cap the two hydraulic hoses leading to the hydraulic filter head.

*NOTE: Always observe hydraulic cleanliness requirements when opening hydraulic lines.*

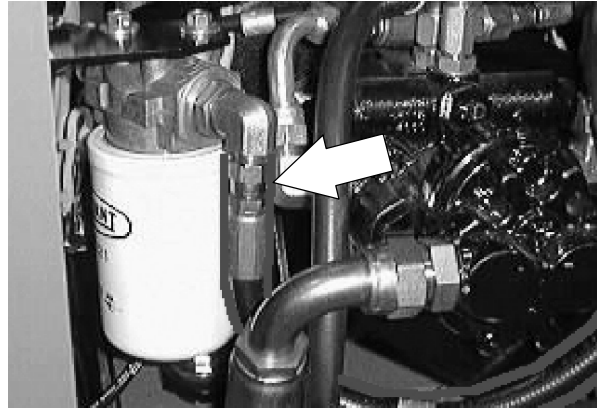

6. Remove the hydraulic fluid filter assembly from the machine.

*NOTE: This will allow access to the engine starter hardware.*

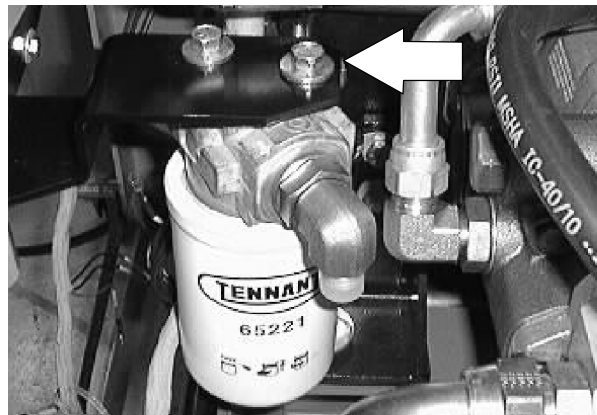

7. Disconnect the wires leading to the starter.

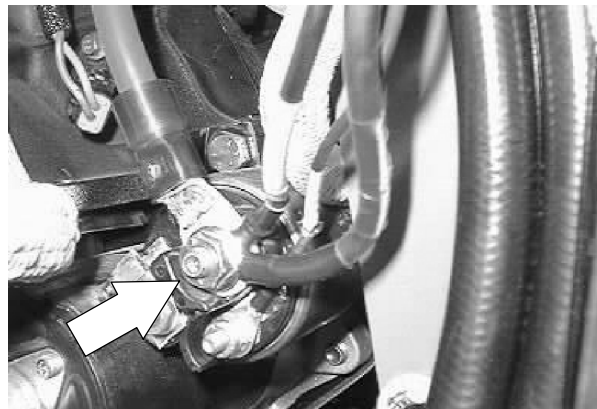

8. Remove the three hex screws holding the starter to the engine bellhousing.

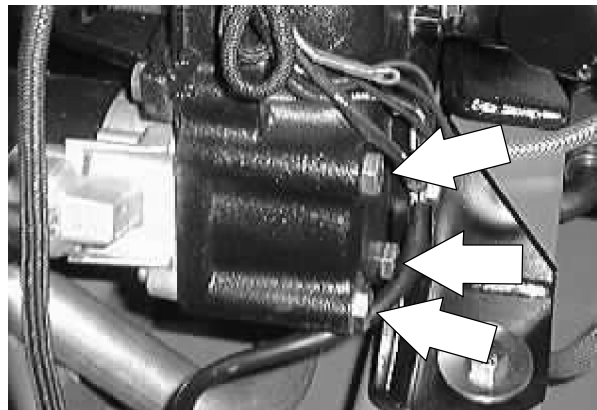

9. Pull the starter straight out of the bellhousing and remove it from the machine.

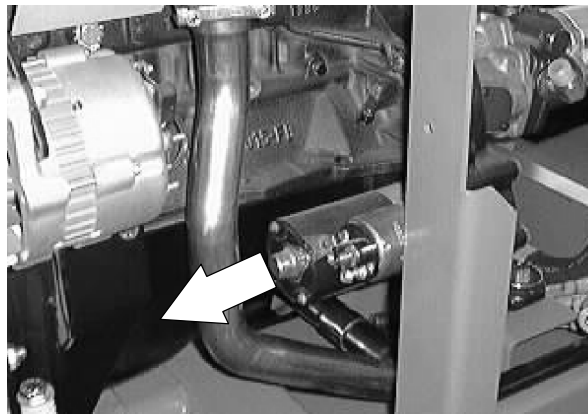

10. Install the new starter in the machine. Align the three holes in the starter with the holes in the bellhousing. Reinstall the three hex screws. Tighten to 18 - 24 Nm (15 - 20 ft lb).

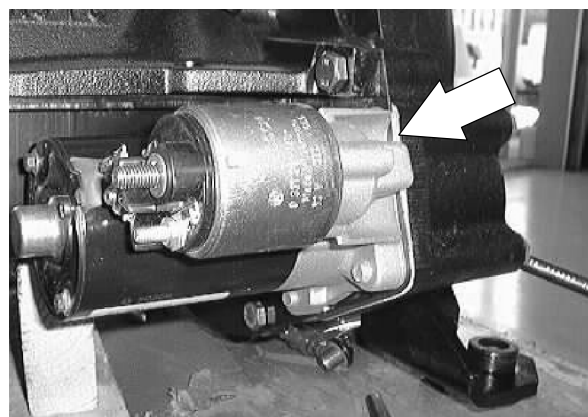

11. Reconnect the wires to the starter. See the schematic in the ELECTRICAL section.



12. Reinstall the hydraulic oil filter assembly. Reconnect the two hydraulic hoses. See hose diagram in HYDRAULIC section.

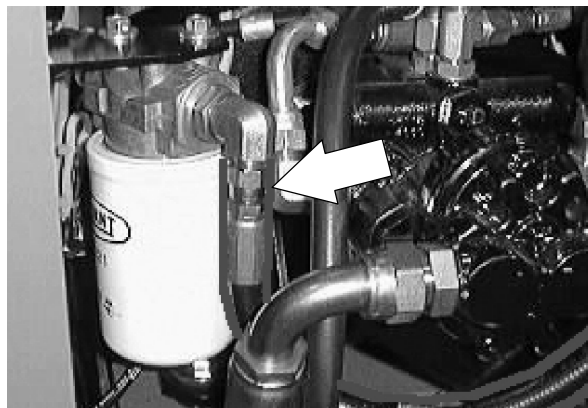

13. Place the rubber dust shield back in position.



14. Reconnect the battery cables. Close the engine cover and side door.

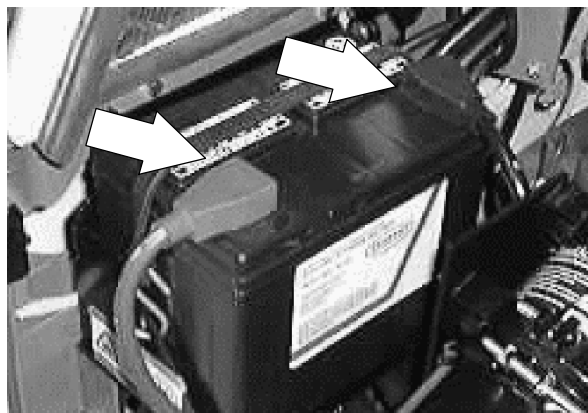

15. Check the starter for proper operation.

## ENGINE-GAS/LP

### TO REMOVE ENGINE

1. Raise the hopper and engage the prop bar.

**⚠ WARNING: Raised Hopper May Fall. Engage Hopper Support Bar.**

*NOTE: If the engine will not start because of a bad starter--use an overhead crane to lift the hopper and engage the prop arm.*

**FOR SAFETY: Before Leaving Or Servicing Machine; Stop On Level Surface, Set Parking Brake., Turn Off Machine And Remove Key.**

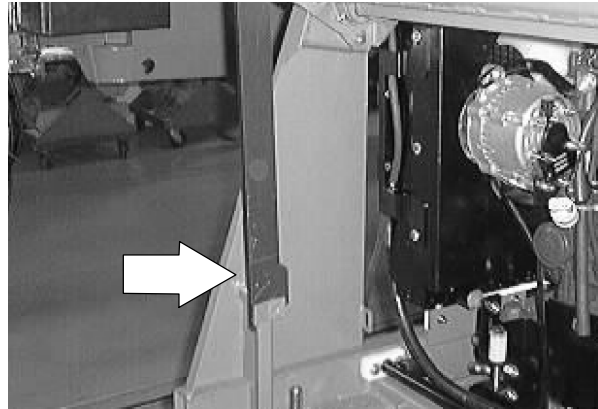

2. Open the engine cover and side door.



3. Remove the engine cover and side door from the machine.

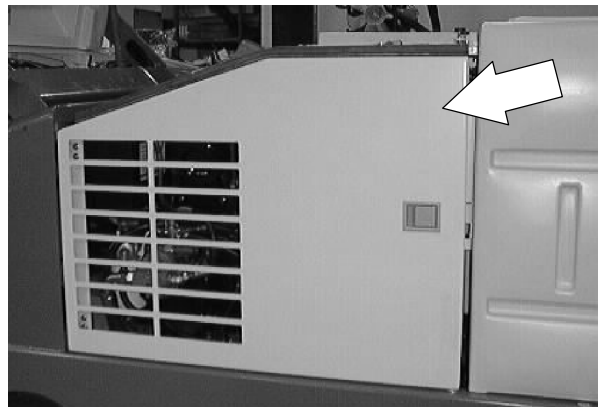

4. Disconnect the battery cables from the battery. Remove the battery and battery tray from the machine.

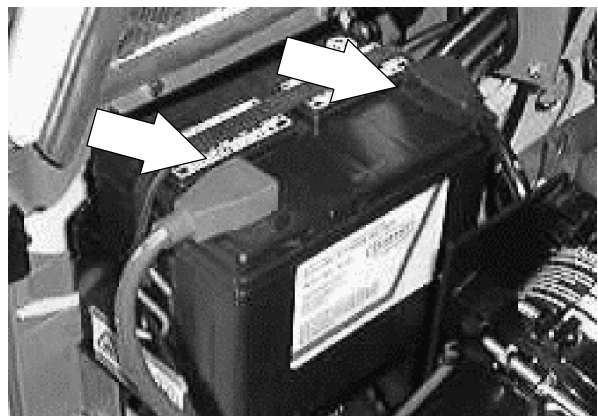

5. Remove the air cleaner and mount bracket from the engine.

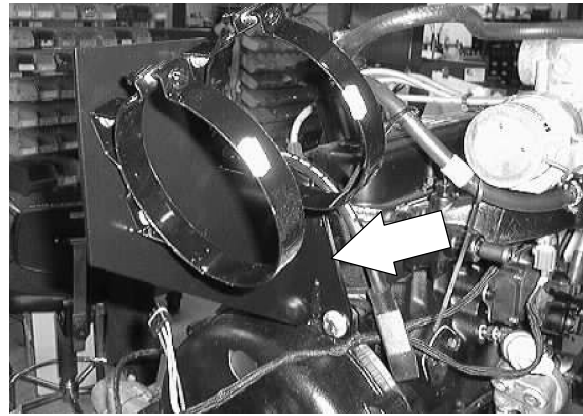

6. Disconnect the choke cable from the engine.

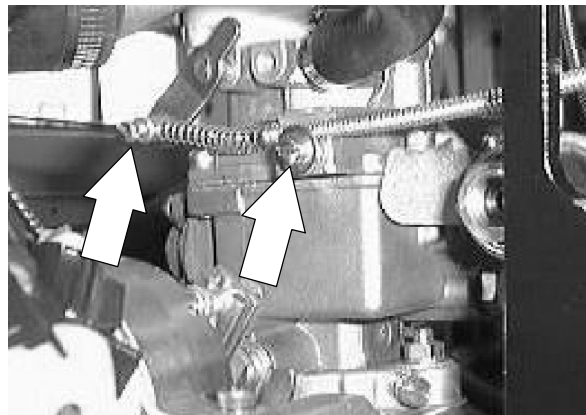

7. Pull the rubber dust shield up and out of the way for access to the front of the engine.



8. If the machine is equipped with a detergent tank--remove for better access.

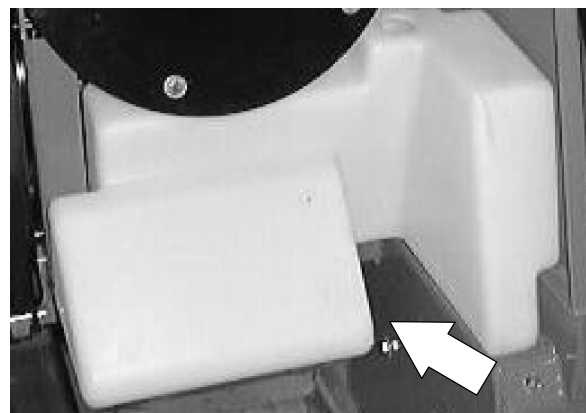

## ENGINE-GAS/LP

9. Disconnect the fuel line at the connection between the hose and steel line on a gas machine. On an LPG machine, disconnect the line leading from the tank to the fuel lockoff / vaporizer.

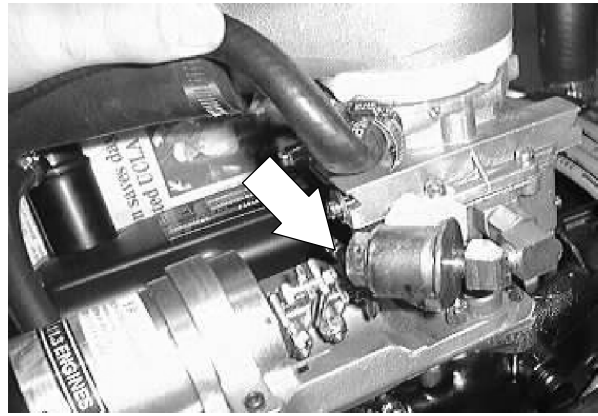

10. Mark, disconnect, and plug the two engine oil lines running to the remote oil filter.

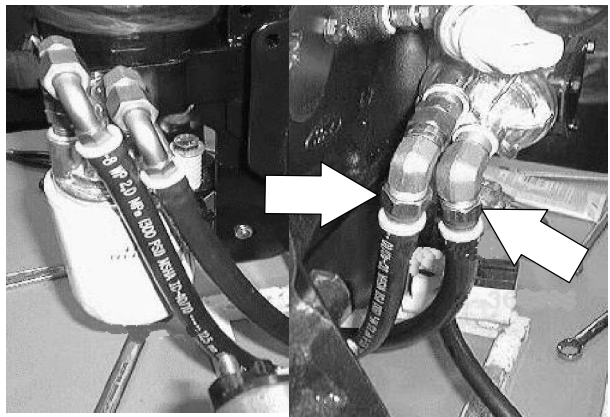

11. Remove the two hex screw holding the radiator grill guard to the frame. Remove the grill from the machine.

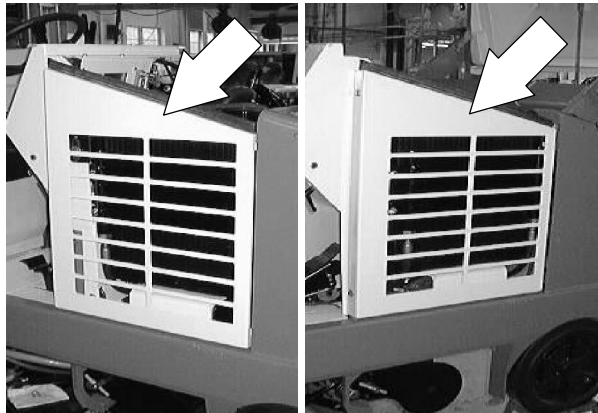

12. Mark, disconnect, and plug the two hydraulic hoses leading to the hydraulic oil cooler on the front of the radiator.

*NOTE: Always observe hydraulic cleanliness requirements when opening hydraulic lines.*

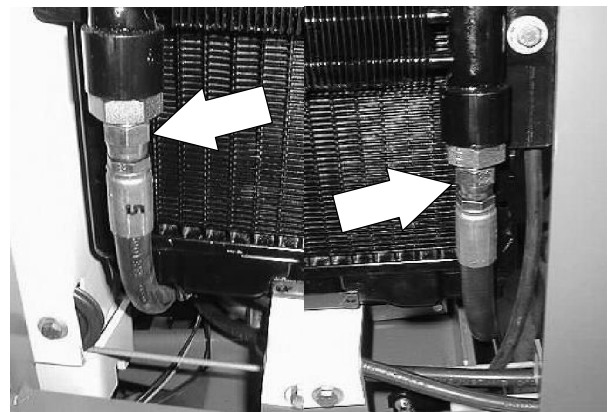



13. Drain the coolant from the radiator.

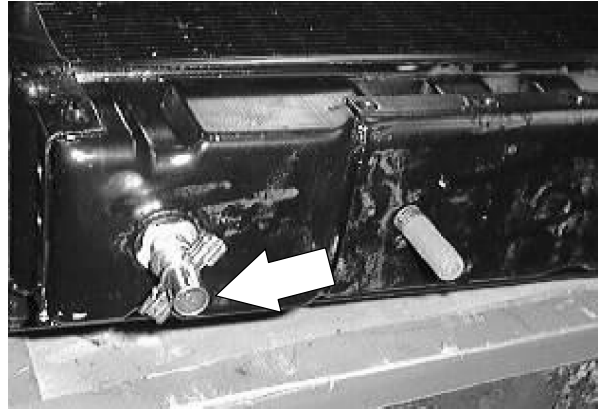

14. Disconnect the upper and lower radiator hoses.

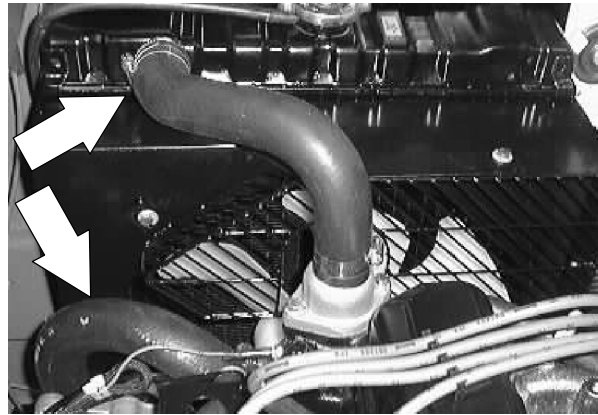

15. Remove the hex screw, spacer, and fender washer holding the top left side of the radiator to the radiator support.

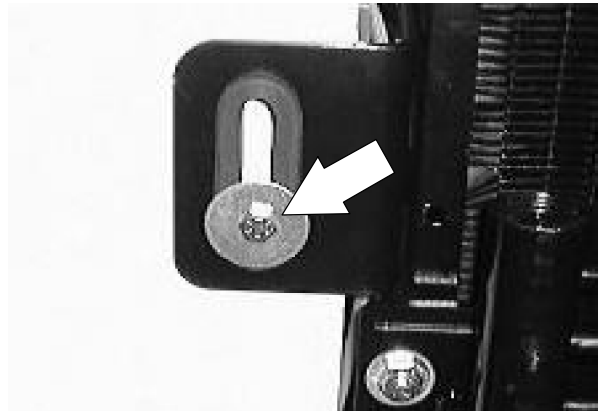

16. Remove the two hex screws and nyloc nuts holding the bottom of the radiator to the mount bracket.

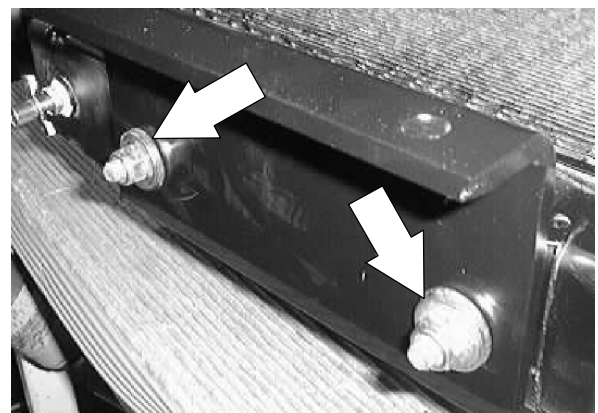

## ENGINE-GAS/LP

17. Pull the radiator back so it clears the engine fan. Remove the radiator, fan shroud, and hydraulic oil cooler from the machine.

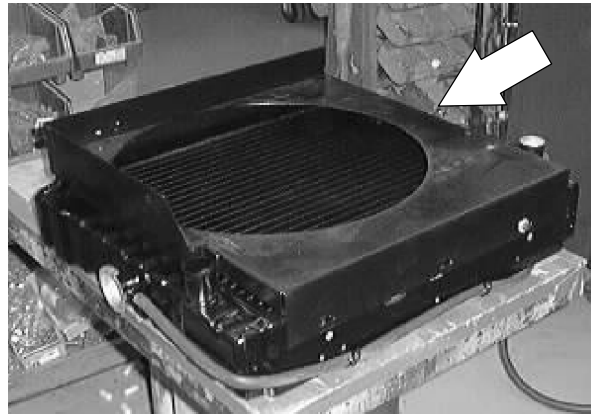

18. Remove the hex screw and compression spring from the front of the accessory pump pivot bracket. Remove the V-belt from the engine sheave.



19. Remove the hex screw, nut, and sleeve holding the hydraulic accessory pump pivot bracket to the front motor mount. Drop the hydraulic pump down onto the frame. DO NOT disconnect the hydraulic hoses leading to the accessory pump.

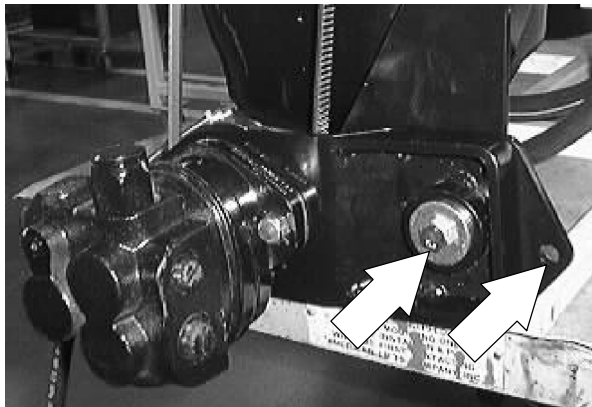

20. Loosen the muffler clamp holding the exhaust pipe to the engine manifold. Pull the exhaust pipe off the manifold and let it drop down, out of the way.

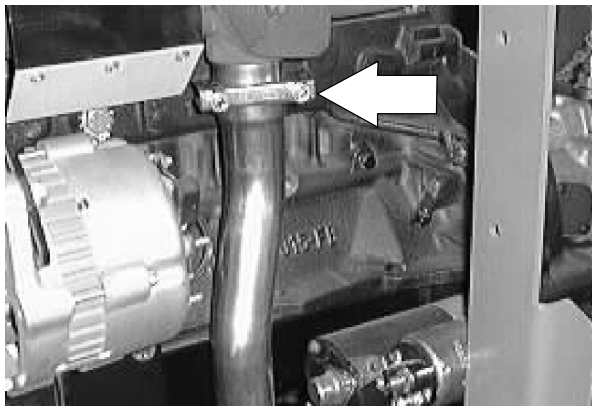

21. Disconnect the wire harness from the alternator, starter, oil sender, temp. sender, ect.

*NOTE: Move the wires out of the way for engine removal.*

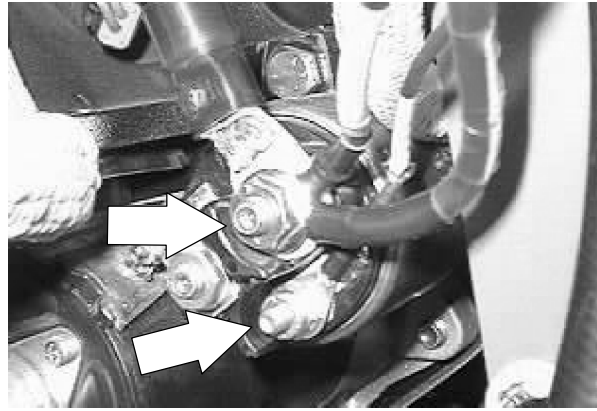

22. Disconnect the ground wires and ground cable from the rear motor mount hex screw.

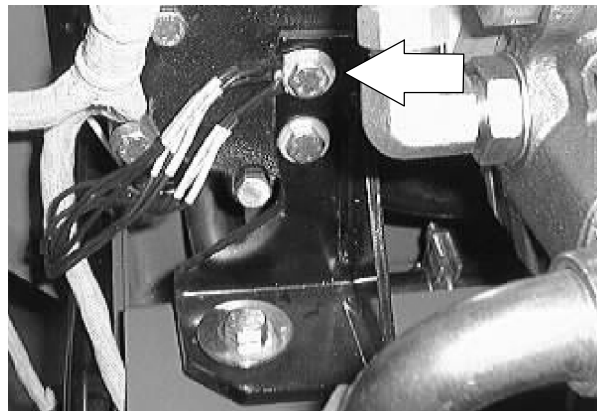

23. Loosen the jam nuts on the propel cable where it attaches to the mount bracket on the bellhousing. Pull the propel cable out of the mount bracket slot.

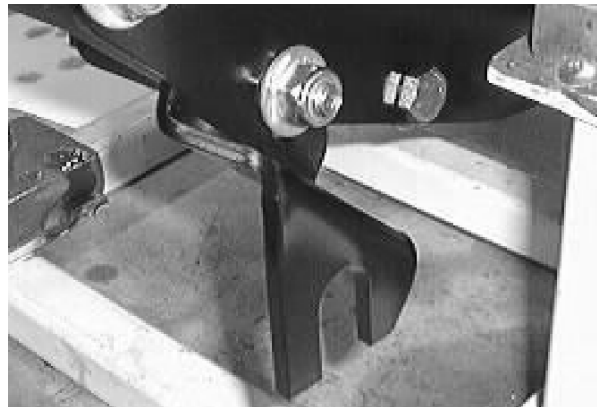

24. Remove the two hex screws holding the propel pump into the flywheel housing.

*NOTE: Leave the hydraulic hoses connected to the propel pump.*

*NOTE: Place a block of wood under the hydraulic pump assembly for support when removing the engine.*



## ENGINE-GAS/LP

25. Pull the propel and accessory pump assembly back, out of the bellhousing.

*NOTE: Leave the hydraulic hoses connected to the propel pump.*

*NOTE: Pull the engine toward the right side of the machine until the hydraulic pump assembly is free of the bellhousing.*

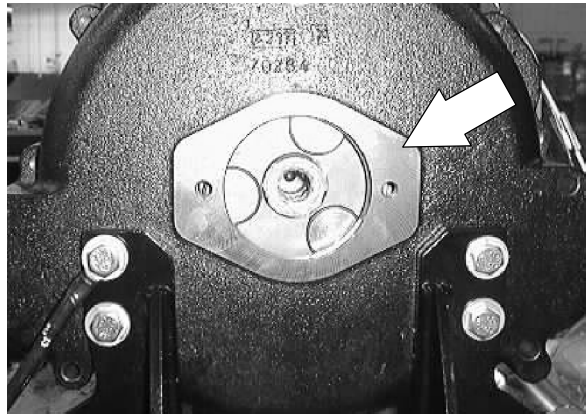

26. Using an overhead hoist, hook a chain through the two pick-up points on the top of the engine. Put a slight amount of tension on the chain.

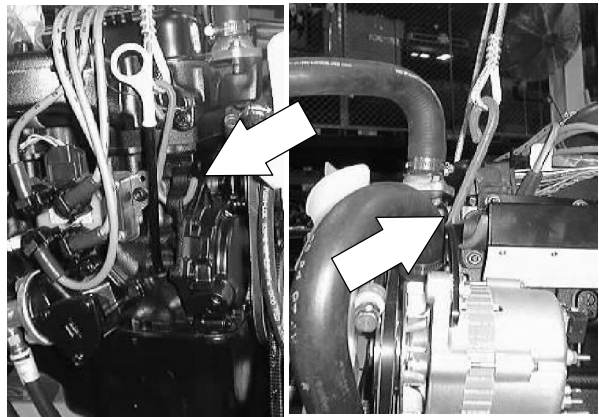

27. Remove the three hex screws and nyloc nuts holding the three motor mounts to the rubber isolators on the frame brackets.

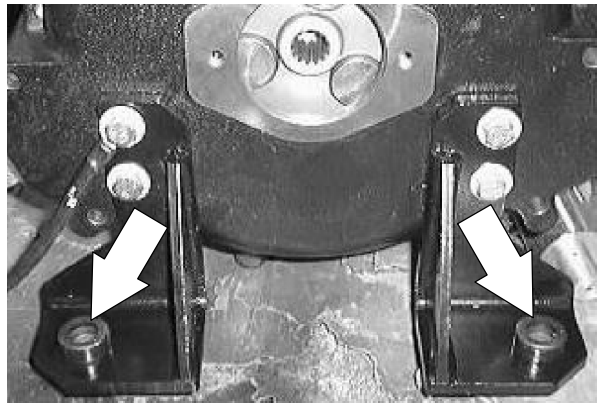

28. The engine can now be carefully lifted out.

*NOTE: Make sure the engine is clear of any wires or hoses before you lift it out of the frame.*

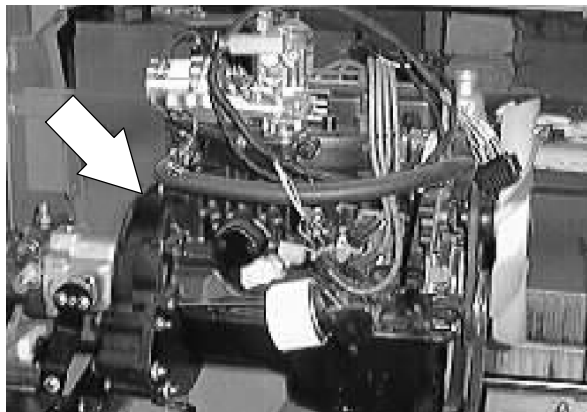

**TO INSTALL ENGINE**

**FOR SAFETY: Before Leaving Or Servicing Machine; Stop On Level Surface, Set Parking Brake., Turn Off Machine And Remove Key.**

1. Using an overhead hoist, hook a chain through the two pick-up points on top of the engine. Carefully position the engine back in the engine compartment.

*NOTE: Make sure the hoses, wire harness, exhaust pipe and propel pump are pulled back out of the way when lowering engine assembly into place.*



2. Slide the engine toward the left side of the machine until the propel pump is positioned into the back of the bellhousing. Install the two hex screws. Use a small amount of blue loctite 242 on the threads. Tighten the hardware to 37 - 48 Nm (26 - 34 ft lb).

*NOTE: Make sure the splines on pump line up with splines in coupler when installing pump.*

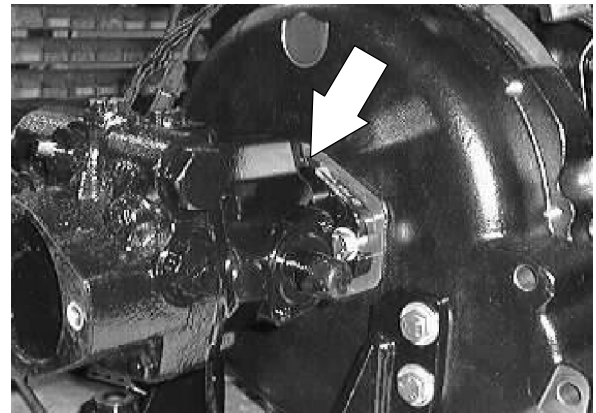

3. Move the engine around until the three motor mounts on the engine line up with the mount holes in the machine frame.

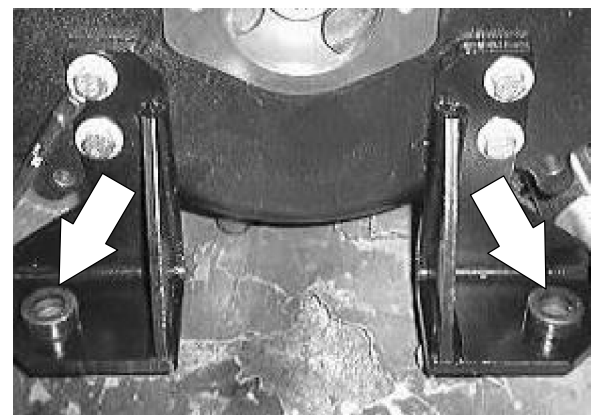

## ENGINE-GAS/LP

4. Reinstall the hex screws, washers, and nylocs in the three motor mounts. Lower the engine all the way. Remove the hoist from the engine. Tighten the hex screws to 64 - 83 Nm (47 - 61 ft lbs).



5. Position the propel cable into the slot on the bellhousing mount bracket.

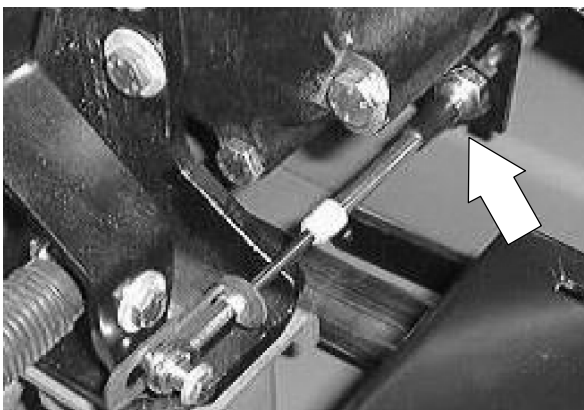

6. Reconnect the ground cable and ground wires to the rear motor mount hardware.

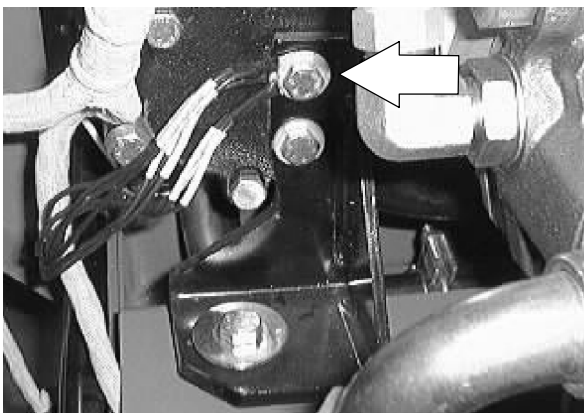

7. Reinstall the exhaust pipe back on the engine manifold. Tighten the muffler clamp tight.

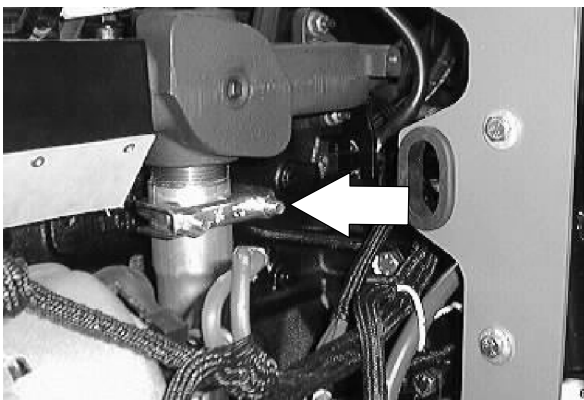

8. Reconnect the wire harness to the engine components; alternator, starter, oil switch, temperature sender, ect. See schematic in the ELECTRICAL section.

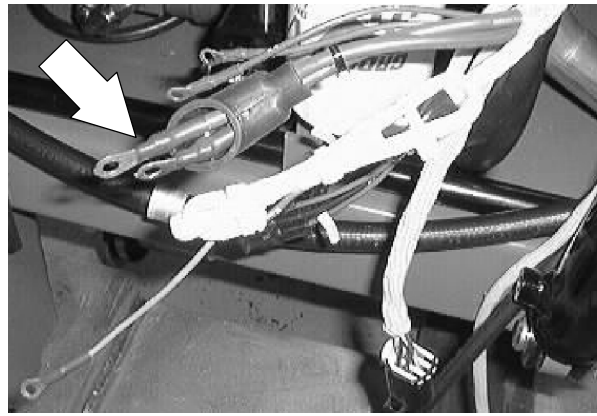

9. Reinstall the accessory pump and pivot bracket onto the motor mount. Tighten the hex screw to 37 - 48 Nm (26 - 34 ft lb). Make sure the sleeve is in place.

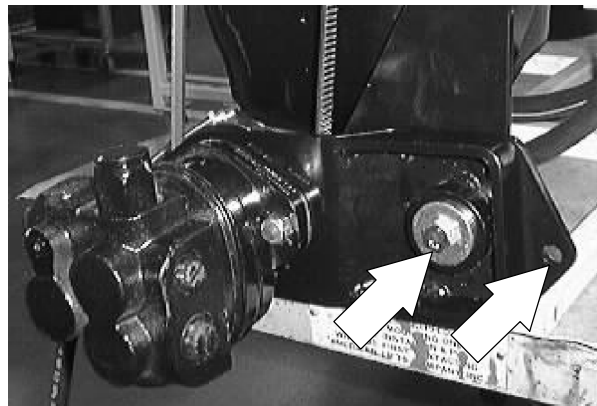

10. Position the accessory pump V-belt onto the engine sheave.

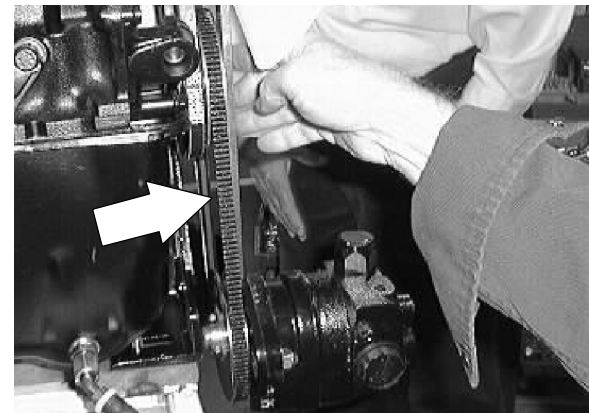

11. The accessory pump belt adjustment is made by turning the bolt on top of the tension spring. The tension spring is located at the front of the engine compartment, near the accessory pump belt sheave. The accessory pump belt is at the proper tension when the tension spring is compressed to 3.81 cm  $\pm$  0.0076 mm (1.5 in  $\pm$  0.030 in).

*NOTE: When adjusting the accessory pump belt tension, measure only the spring and not the washers at either end.*

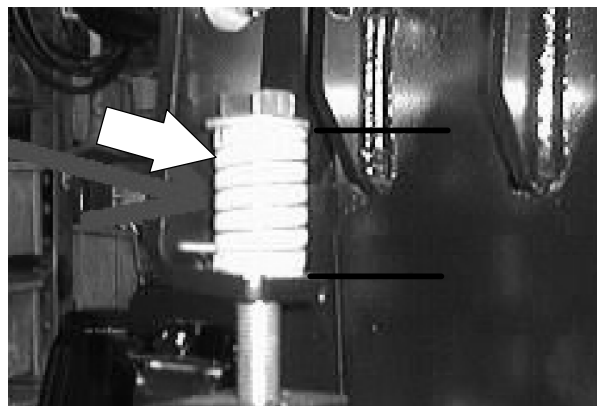

## ENGINE-GAS/LP

- Position the radiator back in the machine. Align the two holes in the bottom of the radiator mount bracket with the holes in the frame. Reinstall the two hex screws and nuts. Leave loose for now.

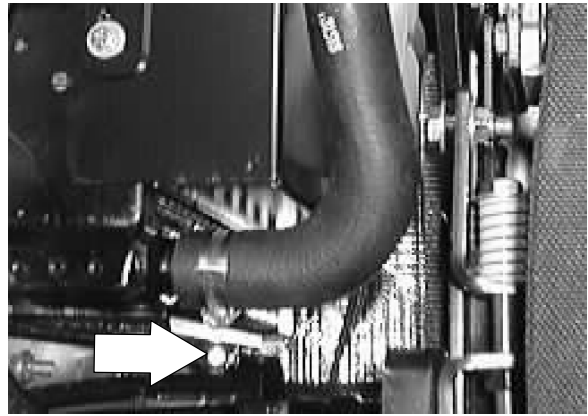

- Reinstall the hex screw and fender washer holding the top of the radiator to the radiator support. Tighten to 6 - 9 Nm (7 - 10 ft lb). Go back and tighten the two hex screws on the bottom of the mount bracket. Tighten to 37 - 48 Nm (26 - 34 ft lb).

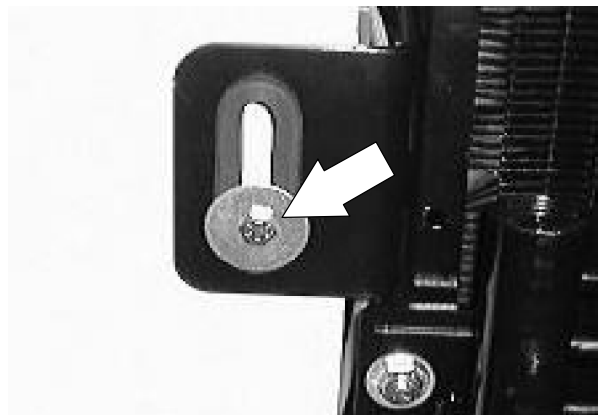

- Reinstall the radiator hoses to engine and fill the radiator with coolant.

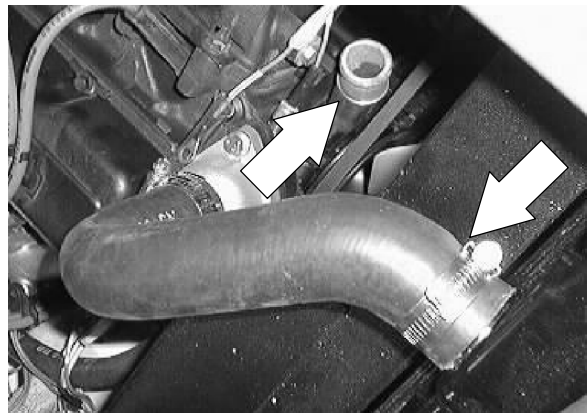

- Reconnect the two engine oil lines running to the remote oil filter.

**NOTE: MAKE SURE THE ENGINE OIL LINES ARE RECONNECTED TO THE PROPER PORT !**

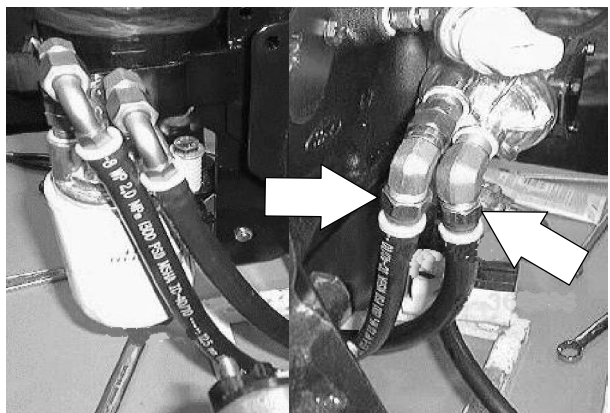



16. Reconnect the two hydraulic hoses to the hydraulic oil cooler on the front of the radiator.

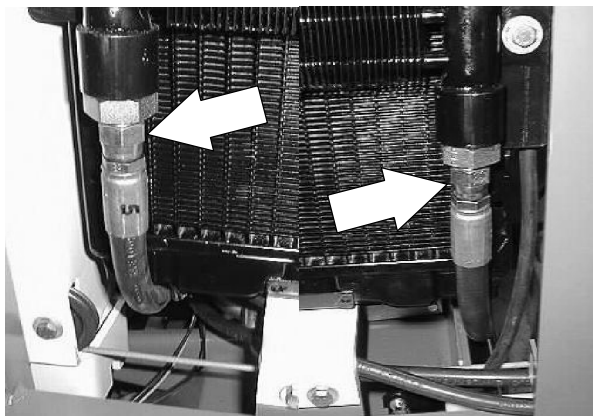

17. Reinstall the radiator grill guard.

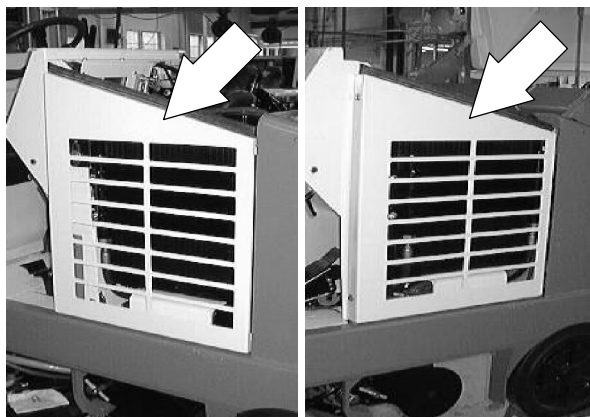

18. Reconnect fuel line on the Gas machine.

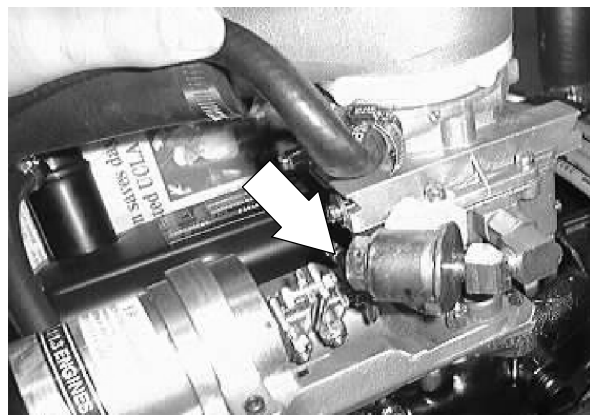

19. On the LPG machine, reinstall the LPG hose to the lockoff/vaporizer.

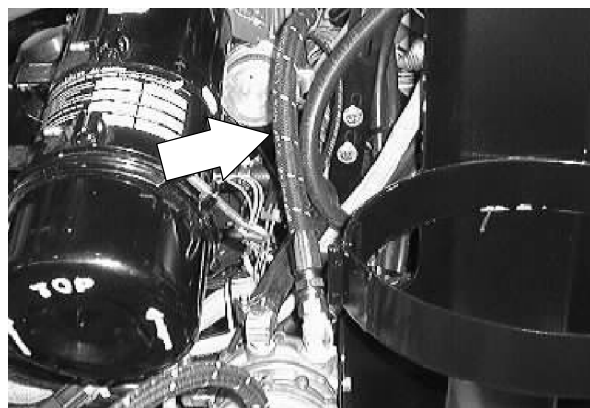

## ENGINE-GAS/LP

20. Reconnect the choke cable on the gas engine.

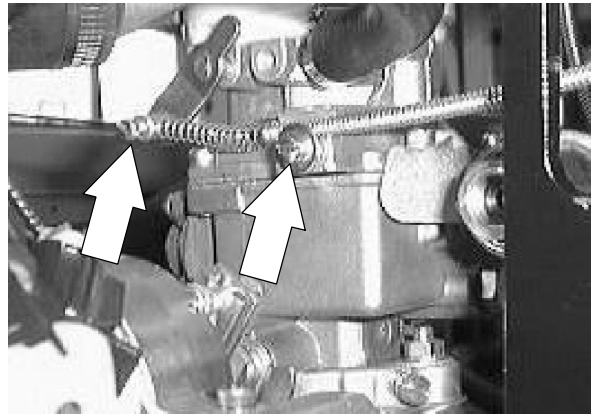

21. Reinstall the air cleaner mount bracket and air cleaner assembly to the engine bellhousing. Tighten to 18 - 24 Nm (15 - 20 ft lb).

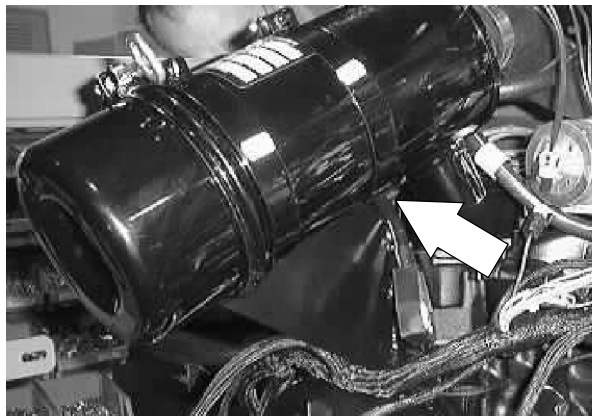

22. Reinstall the battery tray and battery.

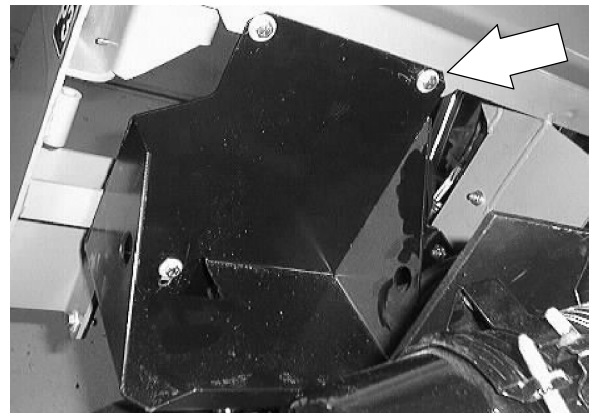

23. Reconnect the battery cables to the battery.



24. Jack up the rear of the machine.

**FOR SAFETY: Block machine tires before jacking machine up. Jack machine up at designated locations only. Block machine up with jack stands.**

25. Start the engine and check for any leaks and proper operation.

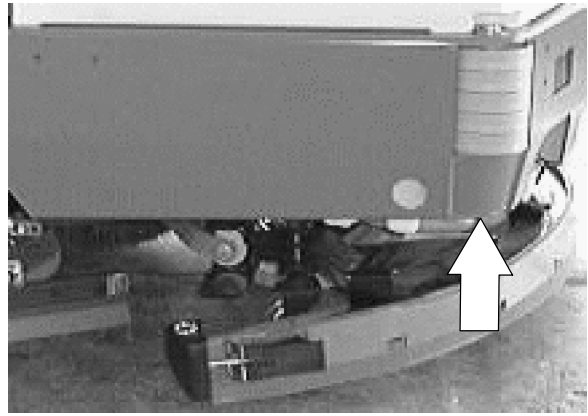

26. Reinstall the front rubber firewall, engine cover, and side door.

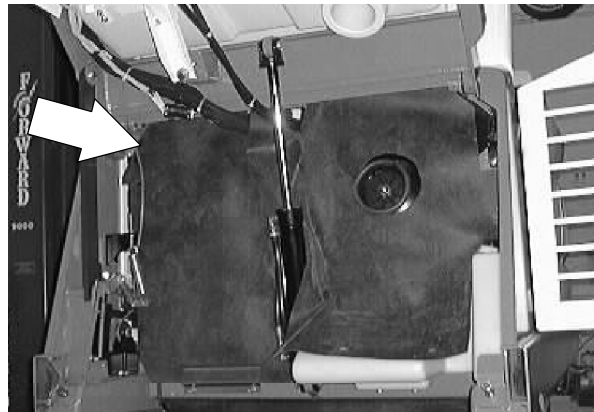



**CONTENTS**

	Page
INTRODUCTION .....	8-3
LUBRICATION .....	8-4
ENGINE OIL .....	8-4
COOLING SYSTEM .....	8-4
ENGINE FAN BELT .....	8-5
TO REPLACE ENGINE FAN/ALTERNATOR BELT .....	8-5
AIR INTAKE SYSTEM .....	8-10
AIR FILTER .....	8-10
AIR FILTER INDICATOR (optional) .....	8-10
TO REPLACE AIR FILTER ELEMENT .....	8-11
FUEL SYSTEM - DIESEL .....	8-13
FUEL FILTER .....	8-14
TO REPLACE THE FUEL FILTER CARTRIDGE .....	8-14
FUEL LINES .....	8-15
ELECTRIC FUEL PUMP .....	8-15
PRIMING FUEL SYSTEM .....	8-16
TO PRIME FUEL SYSTEM .....	8-16
GOVERNOR .....	8-17
TO ADJUST GOVERNOR CONTROL BOX .....	8-17
DIGITAL CONTROLLER SET-UP .....	8-19
TO ADJUST TRANSDUCER (MAGNETIC PICKUP) .....	8-20
CYLINDER HEAD .....	8-20
VALVE TAPPET CLEARANCE ...	8-20
CRANKCASE VENTILATION SYSTEM .....	8-20
TO REPLACE ALTERNATOR ....	8-21
TO REPLACE STARTER .....	8-26
TO REMOVE ENGINE .....	8-29
TO INSTALL ENGINE .....	8-35

**DIESEL ENGINE SERVICE MANUAL**

**KUBOTA V1505 B (E)  
TENNANT Part Number 84660**



---

**INTRODUCTION**

---

This section includes repair information on the engine and related systems, such as fuel, electrical, and drive belts.

## LUBRICATION

### ENGINE OIL

Check the engine oil level daily. Change the engine oil and oil filter every 100 hours of machine operation. Use 10W30 SAE-CC/CD rated engine oil.

Fill the engine with oil to the level indicated on the oil dipstick. The engine oil capacity is 6.15 L (6.5 qt) without the oil filter.

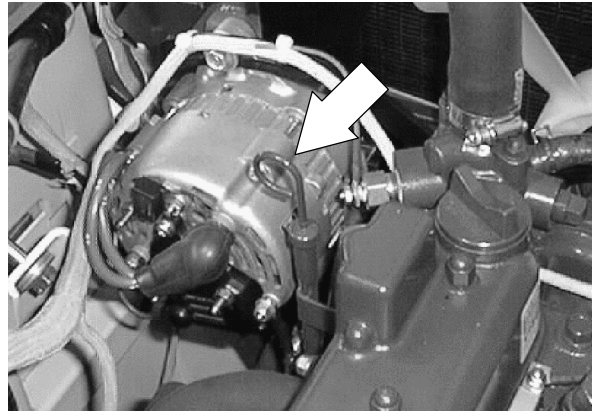

## COOLING SYSTEM

Check the radiator coolant level every 100 hours of operation. Use clean water mixed with a permanent-type, ethylene glycol antifreeze to a  $-34^{\circ}\text{C}$  ( $-30^{\circ}\text{F}$ ) rating.

**FOR SAFETY: When Servicing Machine, Avoid Contact With Hot Engine Coolant.**

Check the radiator hoses and clamps every 200 hours of operation. Tighten the clamps if they are loose. Replace the hoses and clamps if the hoses are cracked, harden, or swollen.



Check the radiator core exterior and hydraulic cooler fins for debris every 100 hours of operation. Blow or rinse all dust, which may have collected on the radiator, in through the engine fan and through radiator fins, opposite the direction of normal air flow. Be careful not to bend the cooling fins when cleaning. Clean thoroughly to prevent the fins becoming encrusted with dust. Clean the radiator and cooler only after the radiator has cooled to avoid cracking.

**FOR SAFETY: When Servicing Machine, Wear Eye And Ear Protection When Using Pressurized Air Or Water.**



Flush the radiator and the cooling system every 400 hours of operation, using a dependable cleaning compound.



## ENGINE FAN BELT

The engine fan belt is driven by the engine crankshaft pulley and drives the alternator pulley. Proper belt tension is 13 mm (0.50 in) from a force of 4 to 5 kg (8 to 10 lb) applied at the mid-point of the longest span.

Check and adjust the belt tension every 100 hours of operation.

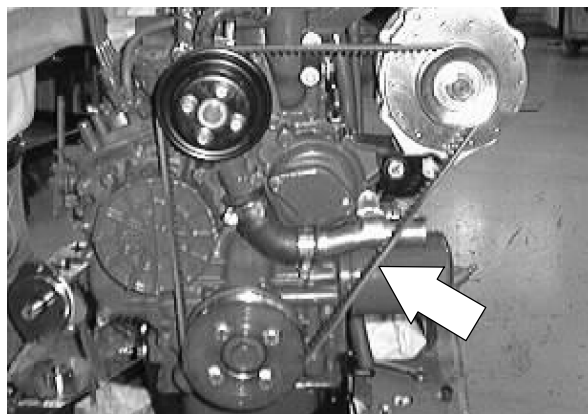

## TO REPLACE ENGINE FAN/ALTERNATOR BELT

1. Raise the hopper and engage the prop bar.



**WARNING: Raised Hopper May Fall. Engage Hopper Support Bar.**

**FOR SAFETY: Before Leaving Or Servicing Machine; Stop On Level Surface, Set Parking Brake, Turn Off Machine And Remove Key.**

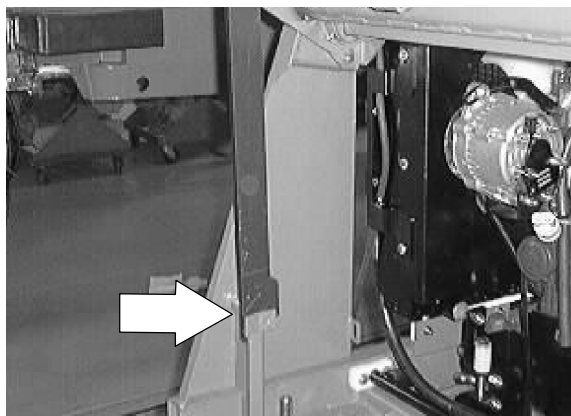

2. Open the engine cover and side door.



3. Disconnect the battery cables from the battery.

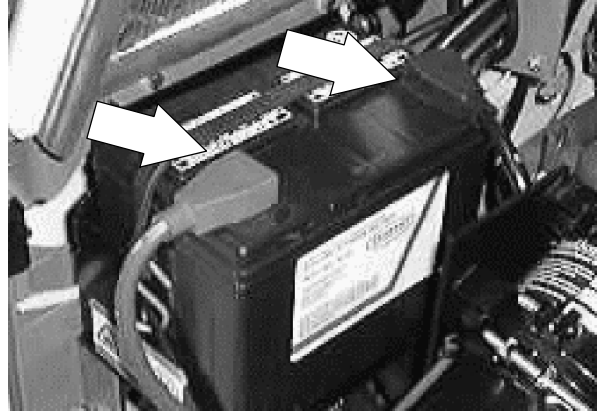

4. Pull the rubber dust shield away from the front of the engine in the area of the alternator.

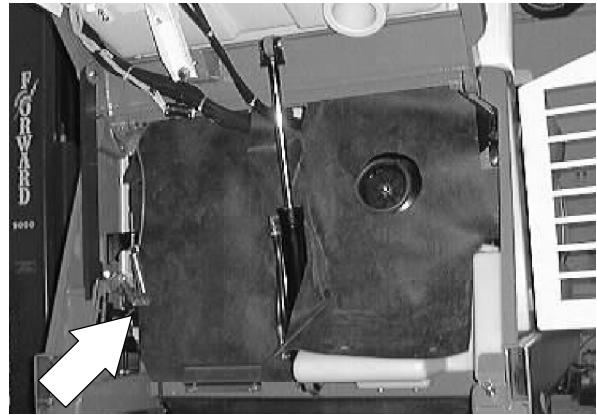

5. Go to the area of the machine in front of the engine. Locate the two hex screws and nuts holding the accessory pump pivot plate to the mount plate. *Loosen these two screws.*

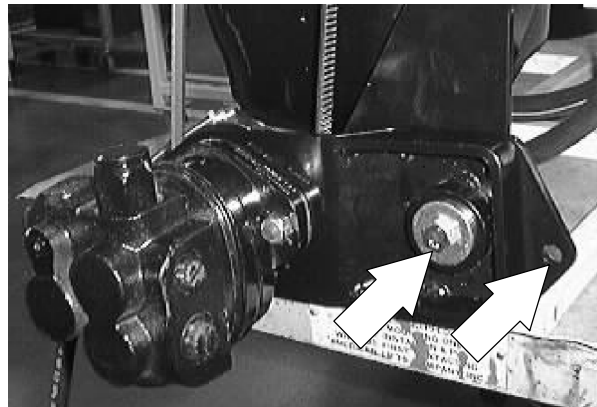

6. Locate the hex bolt and compression spring at the front of the accessory pump mount bracket. Loosen the hex bolt and compression spring.

*NOTE: Remove the accessory pump V-belt from the pump sheave.*



7. Loosen the hex screw holding the top of the alternator to the mount bracket.

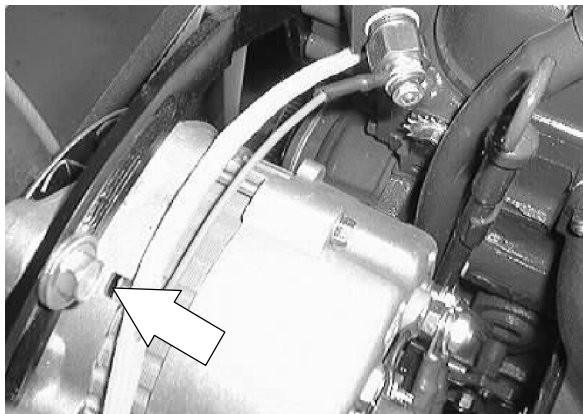

8. Loosen the hex screw and nyloc nut holding the bottom of the alternator to the lower mount bracket.

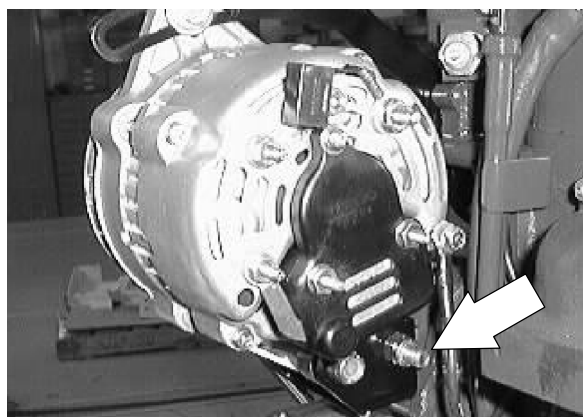

9. Push the alternator in toward the engine. Remove the V-belt from the alternator and engine pulleys.

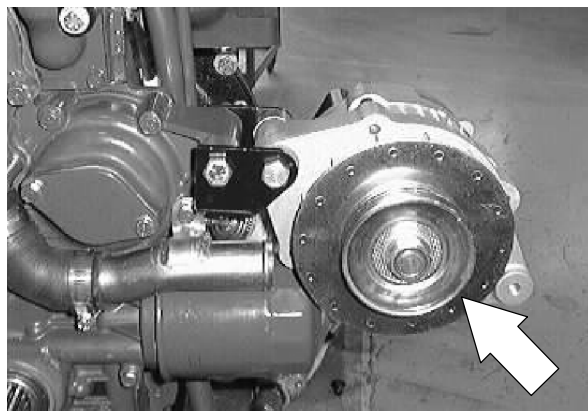

10. Position the new fan belt on the alternator pulley and engine pulleys.

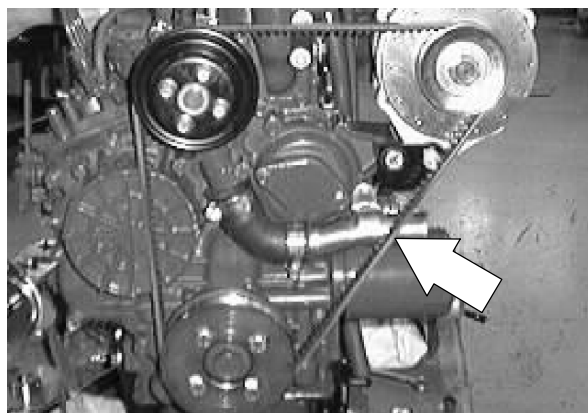

11. Pull the alternator away from the engine to tighten the belt. See adjustment in ENGINE FAN BELT description. Tighten the hex screw to 18 - 24 Nm (13 - 18 ft lb).

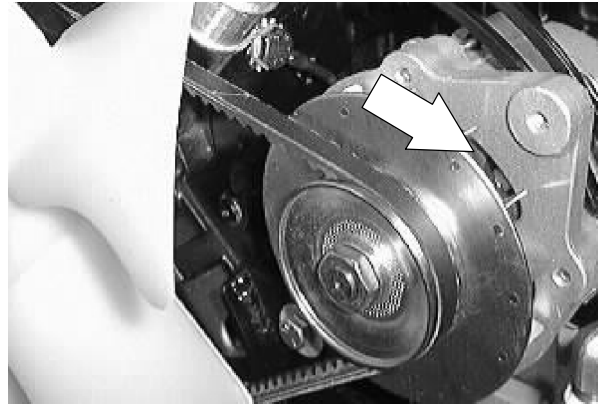

12. Tighten the bottom hex screw to 18 - 24 Nm (15 - 20 ft lb).

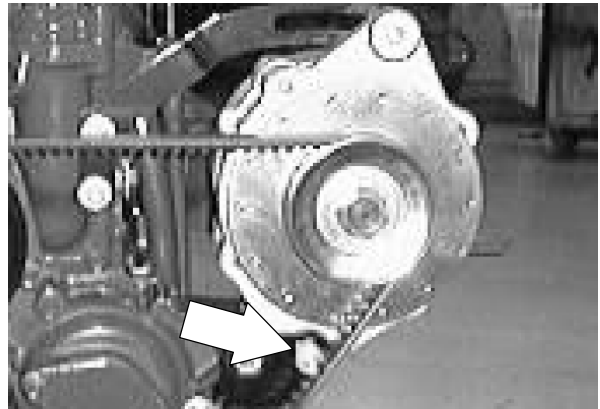

13. Install the hydraulic pump V-belt around the accessory pump sheave.

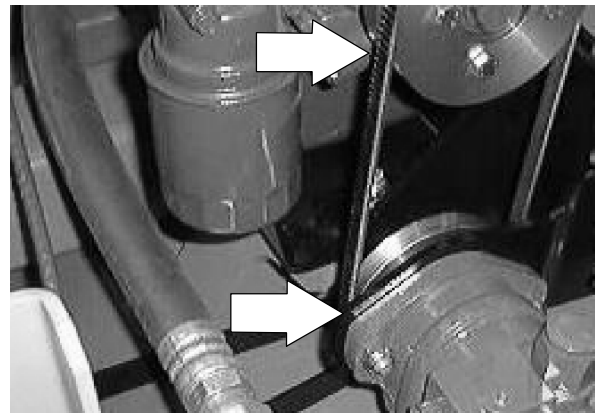

14. The accessory pump belt adjustment is made by turning the bolt on top of the tension spring. The tension spring is located at the front of the engine compartment, near the accessory pump belt sheave. The accessory pump belt is at the proper tension when the tension spring is compressed to 3.81 cm  $\pm$  0.0076 mm (1.5 in  $\pm$  0.030 in).

*NOTE: When adjusting the accessory pump belt tension, measure only the spring and not the washers at either end.*

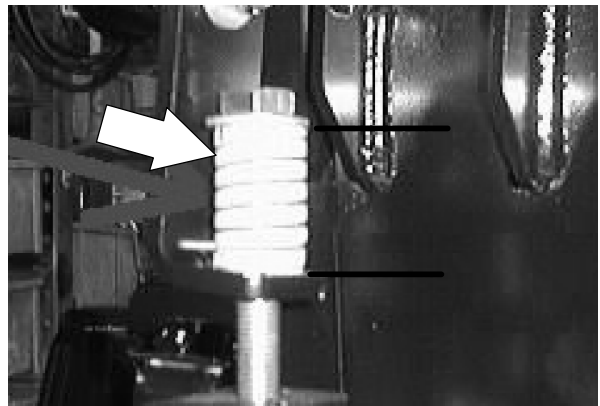

15. Go back and tighten the two pivot plate mount screws to 37 - 48 Nm (26 - 34 ft lb).

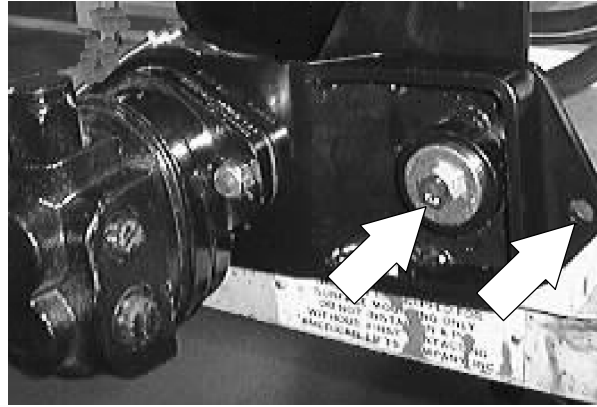

16. Position the rubber dust shield back into the metal bracket.

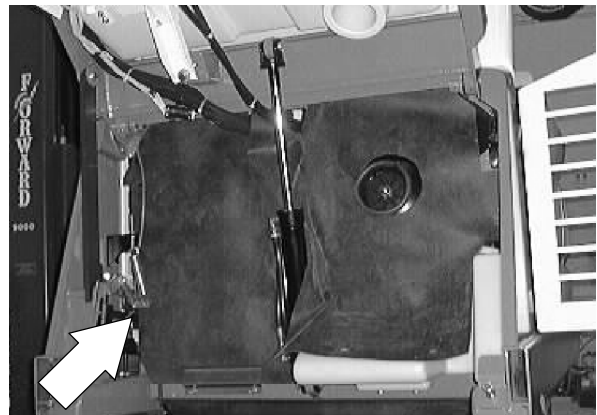

17. Reconnect the battery and start the machine.

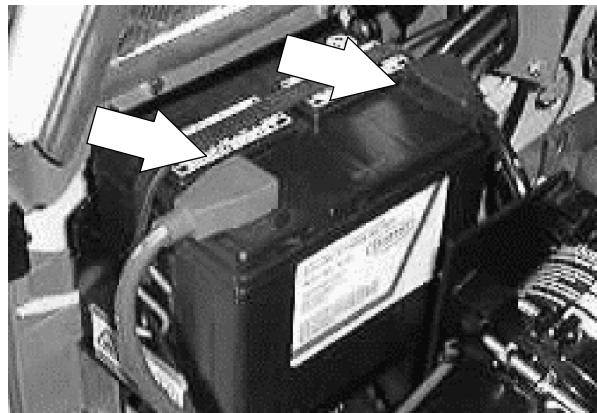

18. Disengage the prop arm and lower the hopper.



19. Check the alternator for proper operation.

## AIR INTAKE SYSTEM

### AIR FILTER

The engine air filter housing has a dust cap and a dry cartridge-type air filter element. Empty the dust cap daily. The air filter must be replaced whenever the filter element is damaged or has been cleaned three times.

Machines with the heavy duty air filter option have a safety element. It is inside the standard element. Replace, do not clean this element after the regular element has been damaged or cleaned three times.

Service the air filter element only when the air filter indicator shows restriction in the air intake system. Do not remove the air filter element unless it is restricting air flow.



### AIR FILTER INDICATOR (optional)

The air filter indicator shows when to clean or replace the air filter element. Check the indicator daily. The indicator's red line will move as the air filter element fills with dirt. Do not clean or replace the air filter element until the red line reaches 5 kPa (20 in H<sub>2</sub>O) and the "SERVICE WHEN RED" window is filled with red. The indicator's red line may return to a lower reading on the scale when the engine shuts off. The red line will return to a correct reading after the engine runs for a while.

Reset the air filter indicator by pushing the reset button on the end of the indicator after cleaning or replacing the air filter element.

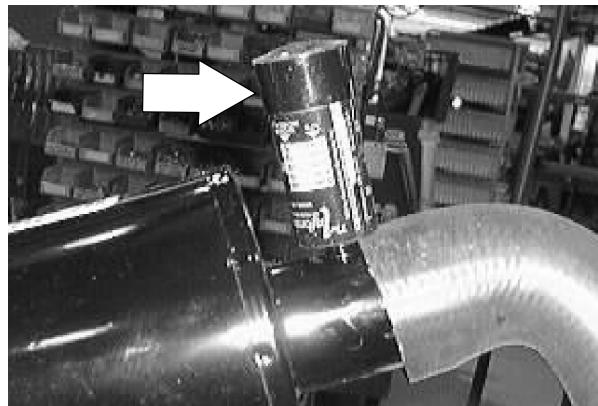

**TO REPLACE AIR FILTER ELEMENT**

**FOR SAFETY: Before Leaving Or Servicing Machine: Stop On Level Surface, Set The Parking Brake, Turn Off Machine And Remove Key.**

1. Open the engine cover and side door.



2. Unscrew the clamp ring on the filter.

3. Remove the dust cap.

4. Empty the dust cap.



5. Remove the filter wing nut.

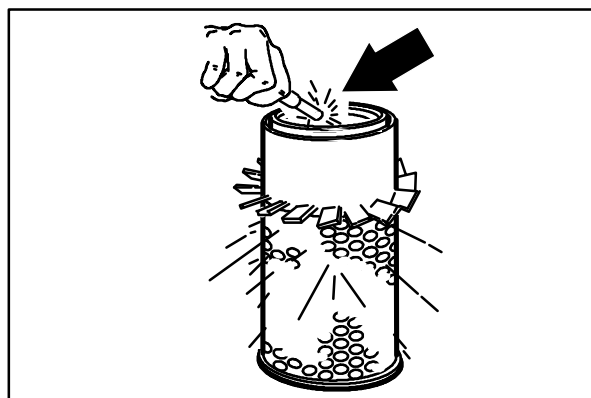

6. Pull the filter element out of the filter housing.
7. Clean the interior of the air cleaner housing with a damp cloth. Clean the element housing sealing surfaces.
8. Using an air hose, direct dry, clean air maximum 205 kPa (30 psi) up and down pleats on the inside of the filter. Do not rap, tap, or pound dust out of the element.

**FOR SAFETY: When Servicing Machine, Wear Eye And Ear Protection When Using Pressurized Air Or Water.**

9. After cleaning the air filter element, inspect it for damage by placing a bright light inside. The slightest rupture requires replacement of the filter. Clean and inspect the seals on the ends of the element. They should be unbroken and flexible. Remember to replace the element after cleaning it three times.
10. Install the new or cleaned filter element so the fins on the element are at the intake end of the air cleaner. Be careful not to damage the fins. Make sure the element is seating evenly. Tighten the element wing nut.
11. Install the dust cap with the arrows pointing up. Tighten the clamp ring to hold it in place. Check all intake hose connections for leaks or abrasions.

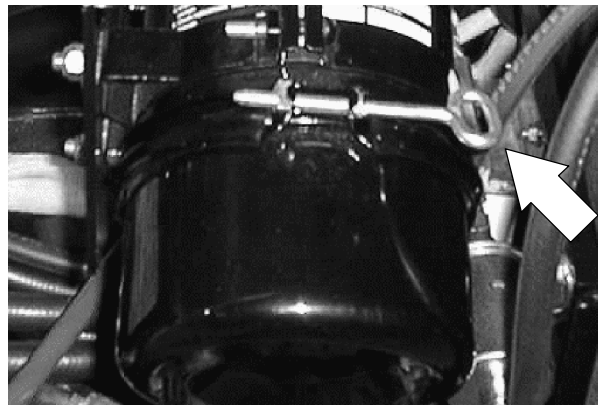
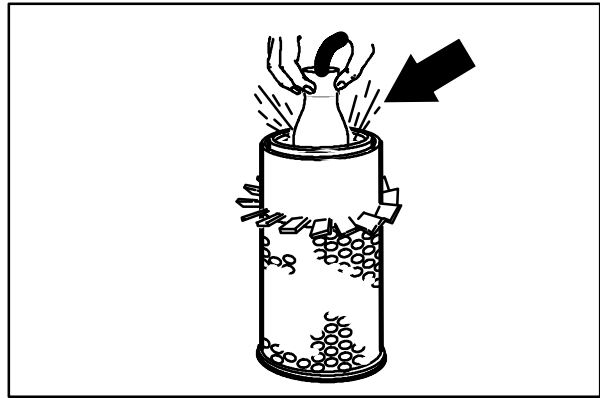

12. Reset the air filter restriction indicator.

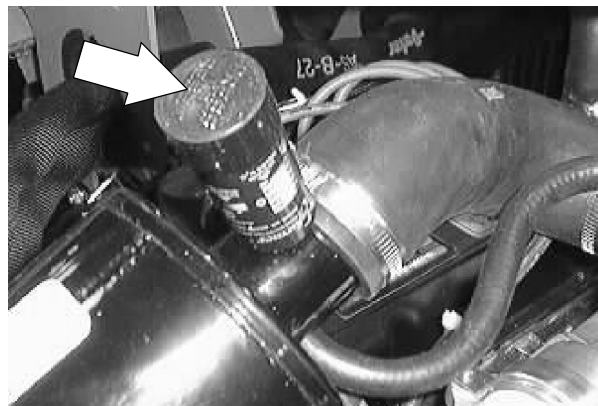

13. Close the engine cover and side door.



---

**FUEL SYSTEM - DIESEL**

---

The diesel fuel system is made up of five basic components which are: fuel tank, electric fuel pump, fuel filter/water trap, injection pump, and injectors.

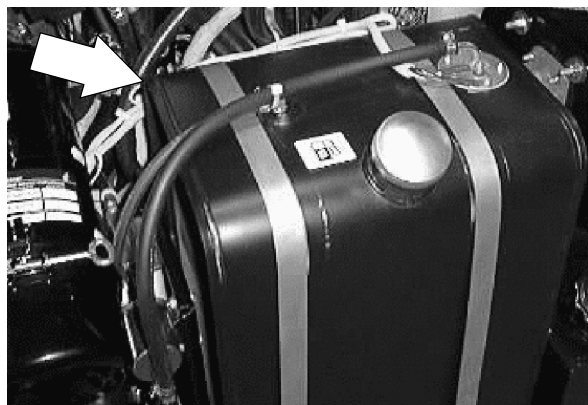

Fuel flows from the fuel tank through the electric fuel pump and is pumped to the fuel filter/ water trap. The water trap-filter separates water and impurities from the fuel. From the fuel water trap-filter, fuel continues on to the injection pump. The injection pump pressurizes and sends fuel to the injectors. The injectors atomize and inject proper amounts of fuel into the combustion chamber at the proper times. Excess fuel is returned to the fuel tank through an overflow pipe.

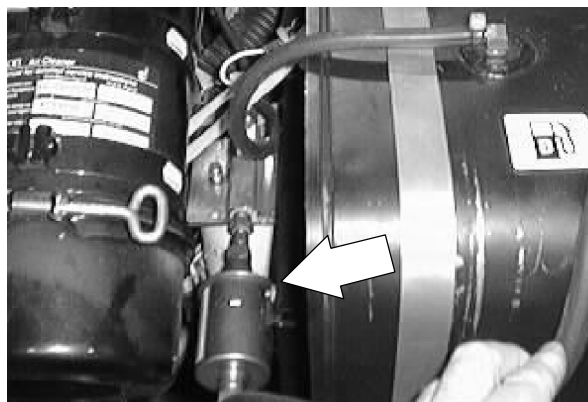

### FUEL FILTER

The large fuel filter cartridge filters impurities from the fuel. Water is also removed from the fuel with this filter/water separator.

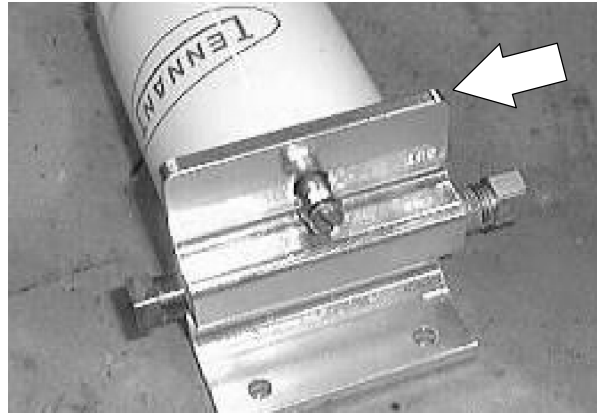

### TO REPLACE THE FUEL FILTER CARTRIDGE

**FOR SAFETY: Before Leaving Or Servicing Machine; Stop On Level Surface, Set Parking Brake, And Turn Off Machine.**

1. Loosen the unit vent plug and open the water trap drain to drain diesel fuel.

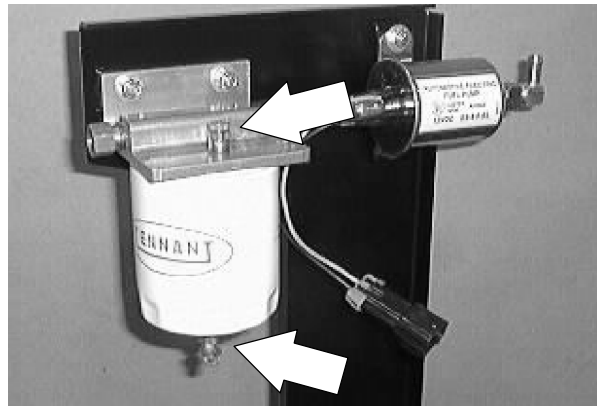

2. Remove the filter cartridge from the filter head.
3. Lubricate the o-ring of the new filter cartridge and spin it onto the filter head.

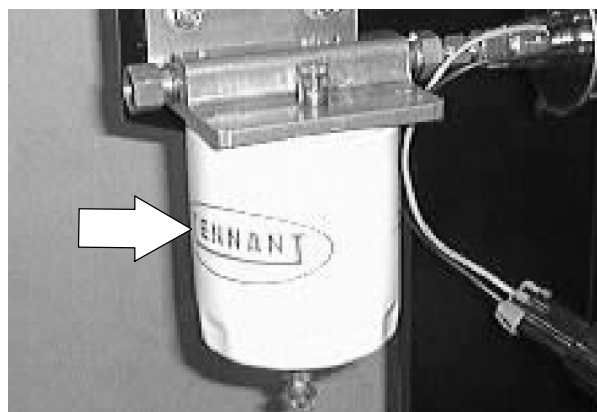

4. Bleed the fuel lines of air as described in TO PRIME FUEL SYSTEM instructions.

## FUEL LINES

Check the fuel lines every 50 hours of operation. If the clamp band is loose, apply oil to the screw of the band, and securely tighten the band.

Made of rubber, the fuel lines become worn out whether the engine has been used much or not. Replace the fuel lines and clamp bands every two years.

If the fuel lines and clamp bands are found worn or damaged before two years' time, replace or repair them at once. Bleed the fuel system after replacement of any of the fuel lines, see TO PRIME THE FUEL SYSTEM. When the fuel lines are not installed, plug both ends with clean cloth or paper to prevent dirt from entering the lines. Dirt in the lines can cause fuel injection pump malfunction.

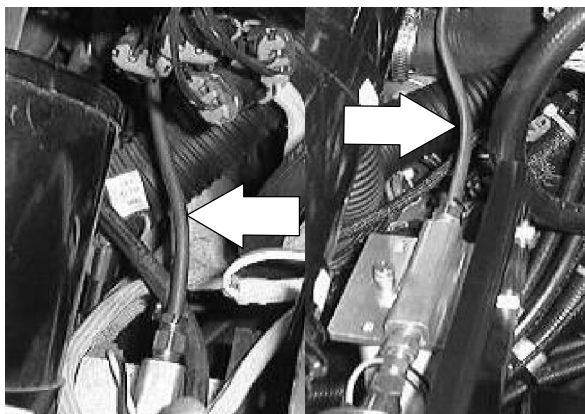

## ELECTRIC FUEL PUMP

The fuel pump is operated with 12 volts from the battery. Fuel is drawn from the fuel tank to the electric fuel pump. The fuel then flows through the fuel/water separator and on to the injector pump.



### PRIMING FUEL SYSTEM

Priming the fuel system removes pockets of air in the fuel lines and fuel components. Air in the fuel system will prevent smooth engine operation.

Prime the fuel system after running out of fuel, changing fuel filter element or repairing a fuel system component.

### TO PRIME FUEL SYSTEM

**FOR SAFETY: Before Leaving Or Servicing Machine; Stop On Level Surface, Set Parking Brake, And Turn Off Machine.**

1. Make sure the fuel tank is full.

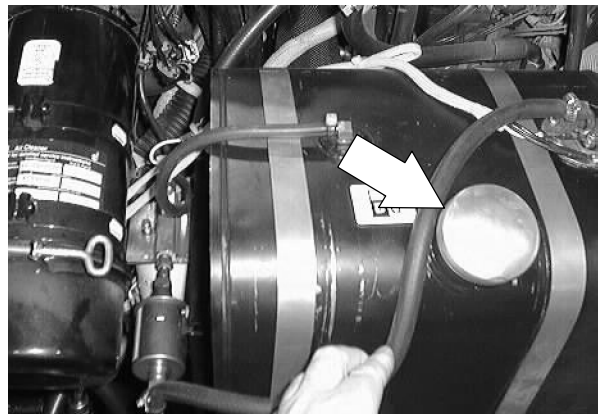

2. Open the air vent on top of the fuel filter.
3. Start the engine and allow it to run until a steady stream of fuel flows from the vent.
4. Close the air vent and shut off the engine.
5. Clean up any fuel that was spilled during the bleeding process.

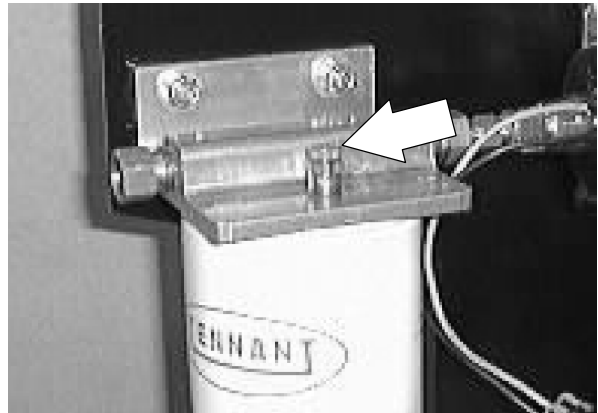

**GOVERNOR**

The electronic governor controls engine speed. The governor consists of a mag pick-up assembly, a control box, and an throttle actuator mounted on the back of the injector pump. The control box regulates the actuator, which in turn controls the throttle.

The electronic governor is factory set and is not user serviceable.

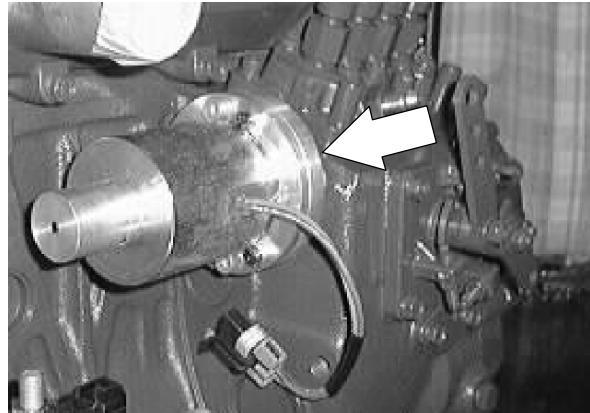

**TO ADJUST GOVERNOR CONTROL BOX**

1. Raise the rear of the machine and place jack stands under the frame.

**FOR SAFETY: Block machine tires before jacking machine up. Jack machine up at designated locations only. Block machine up with jack stands.**

2. Start the engine and warm to operating temperature.



3. Move the speed switch to idle, all accessories off.
4. Move the speed switch to the fast position.

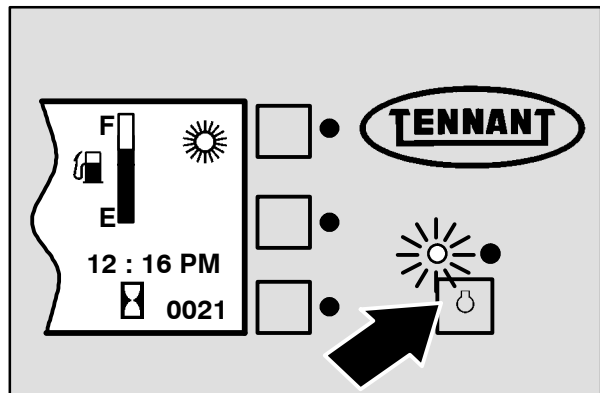

5. FOR ANANLOG CONTROLLER: If engine speed surges occur, turn the surge adjustment screw (located on back of governor control box under hole plug) counterclockwise one-eighth of a turn.

Repeat until surges do not occur.

Replace hole plug if removed for adjustment.

6. FOR DIGITAL CONTROLLER: Follow the instructions on the *DIGITAL CONTROLLER SET-UP* diagram.

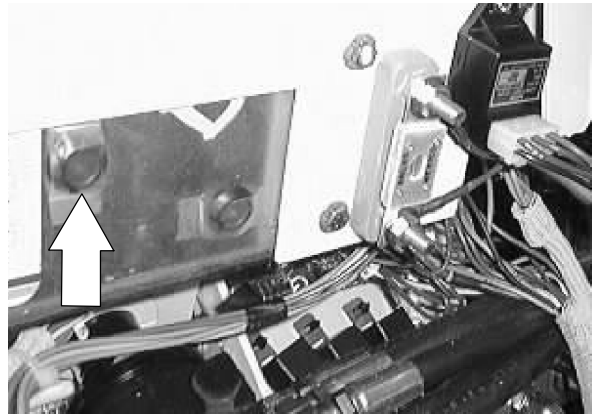

7. Remove the jack stands and lower the machine.

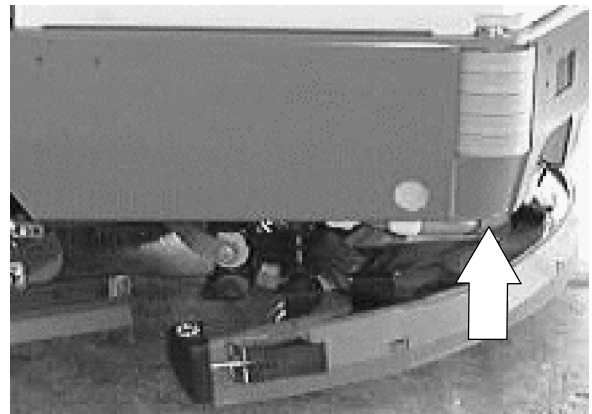

Set DIP switches according to controller label, before installing to controller.



**Digital Controller**  
p/n 374763

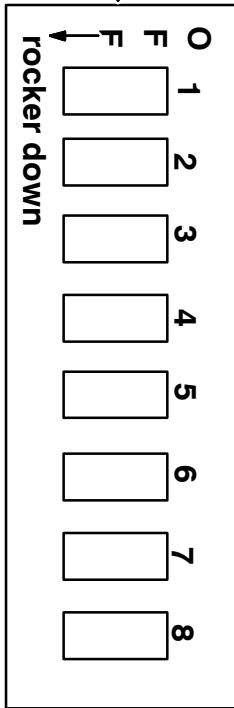

Controller Set-Up:		DIP Switch Settings:					
Program Number	Machine Model	Switch number starting from left					
		#1	#2	#3	#4	#5	#6
#1	355/6500/6550/8200/8210/7400 Gas/LP	ON	OFF	OFF	OFF	OFF	OFF
#2	6550/7400/8200/8210 Diesel w/ SJ actuator (linear)	OFF	ON	OFF	OFF	OFF	OFF
#3	355/6500/6550/7400 Diesel w/ SF (rotary) actuator	ON	ON	OFF	OFF	OFF	OFF
#4	800/810 Gas	OFF	OFF	ON	OFF	OFF	OFF
#5	800/810 LP	ON	OFF	ON	OFF	OFF	OFF
#6	800/810 550/1550 Diesel	OFF	ON	ON	OFF	OFF	OFF
#7	8400/8410 Gas	ON	ON	ON	OFF	OFF	OFF
#8	8400/8410 LP	OFF	OFF	OFF	ON	OFF	OFF
#9	8400/8410 Diesel	ON	OFF	OFF	ON	OFF	OFF
#10	6500II LP / Gas	ON	ON	OFF	ON	OFF	OFF
#11	6500II/6550II Diesel	OFF	OFF	ON	ON	OFF	OFF
#12	800/810 Diesel – 2 spd	ON	OFF	ON	ON	OFF	OFF
#13	800/810 Gas - 2 spd	OFF	ON	ON	ON	OFF	OFF
#14	800/810 LP – 2 spd	ON	ON	ON	ON	OFF	OFF
#15	355/6500/6550/8200/8210/7400 Gas/LP – special 2 spd	OFF	OFF	OFF	OFF	ON	OFF
#16	6550/7400/8200/8210 Diesel w/ SJ actuator (linear) sp. 2 spd	ON	OFF	OFF	OFF	ON	OFF
Special DIP Settings: ↓		Special DIP Settings: ↓					
Engines with Distributor		Altitude compensation					
#7		#8		RPM added			
ON	Distributor	ON	OFF	200 rpm			
OFF	Non Distributor (DIS)	OFF	ON	0 rpm			

Gain pot and Trouble shooting LED can be seen through here:  
←

**DIGITAL CONTROLLER SET-UP**

### TO ADJUST TRANSDUCER (MAGNETIC PICKUP)

**FOR SAFETY: Before Leaving Or Servicing Machine: Stop On Level Surface, Set The Parking Brake, Turn Off Machine And Remove Key.**

1. Turn the flywheel until you see a starter ring gear tooth centered in the mag pickup hole.

*NOTE: On existing engines in the field, there is one tooth marked white for ease of visibility. On new engines, you may want to mark a tooth white in the vicinity of the mag pickup and then turn the flywheel until it is centered.*

2. Screw the new transducer (mag pickup) in until it lightly hits the tooth.
3. Back the transducer (mag pickup) out 1/4 turn to 1/2 turn (.015 + or - .005 in. gap). Tighten the jam nut.
4. Slowly turn the engine over to make sure the flywheel does not hit the transducer (mag pickup).
5. If it hits, turn the transducer (mag pickup) out 1/4 more and repeat step 4.

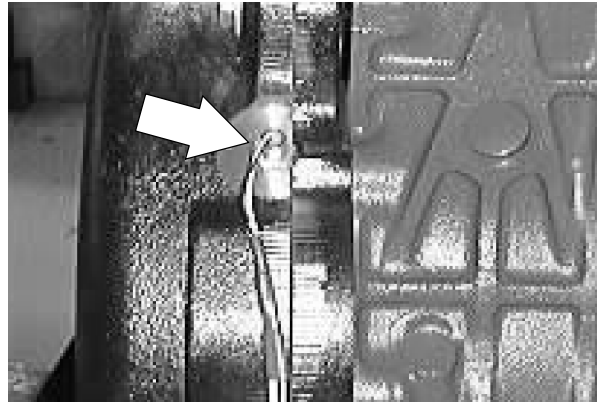

---

### CYLINDER HEAD

---

#### VALVE TAPPET CLEARANCE

The valve tappet clearance must be checked and adjusted if necessary every 400 hours of operation. See Kubota Diesel Engine Workshop Manual.

#### CRANKCASE VENTILATION SYSTEM

See Kubota Diesel Engine Workshop Manual.



**TO REPLACE ALTERNATOR**

1. Raise the hopper and engage the prop bar.

**⚠ WARNING: Raised Hopper May Fall. Engage Hopper Support Bar.**

**FOR SAFETY: Before Leaving Or Servicing Machine; Stop On Level Surface, Set Parking Brake, Turn Off Machine And Remove Key.**

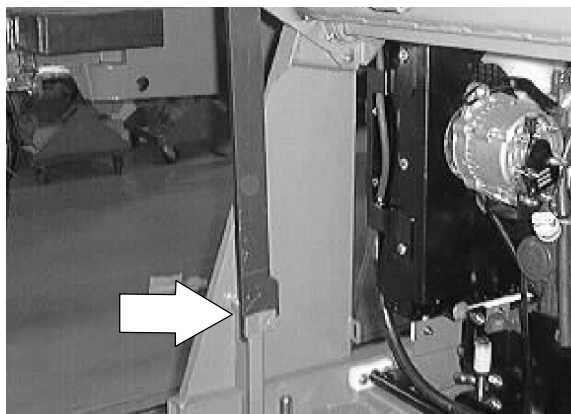

2. Open the engine cover and side door.



3. Disconnect the battery cables from the battery.

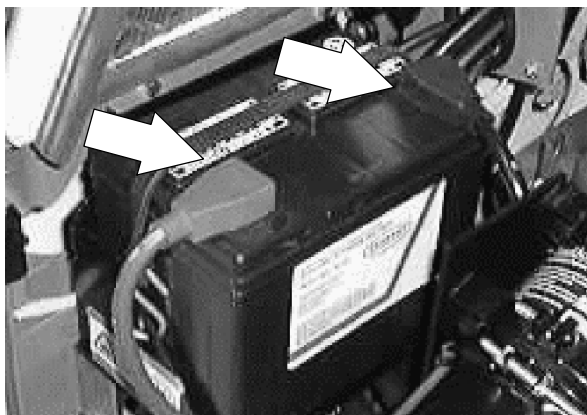

4. Pull the rubber dust shield away from the front of the engine in the area of the alternator.

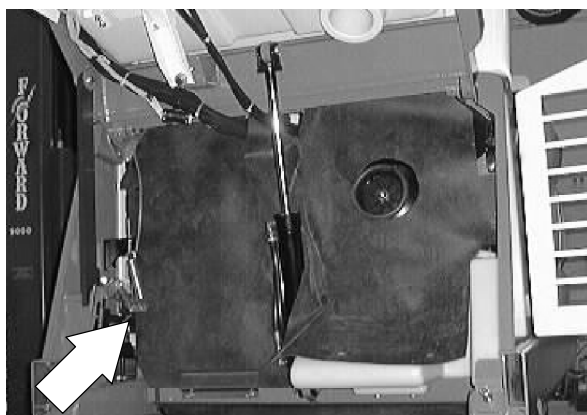

5. Cut any plastic wire ties holding the wire harness to the alternator bracket.

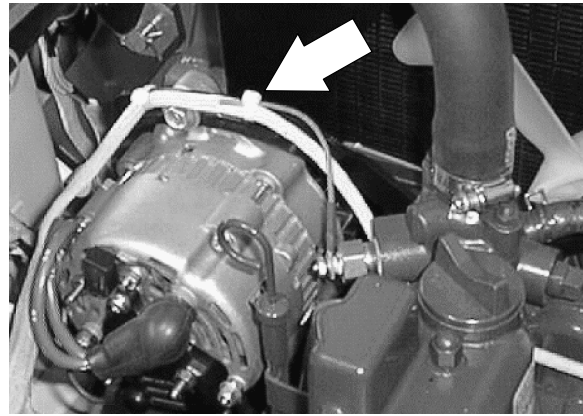

6. Loosen the hex screw holding the top of the alternator to the mount bracket.

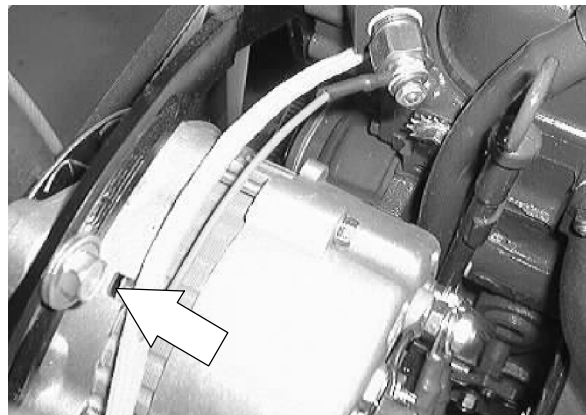

7. Loosen the hex screw and nyloc nut holding the bottom of the alternator to the lower mount bracket.

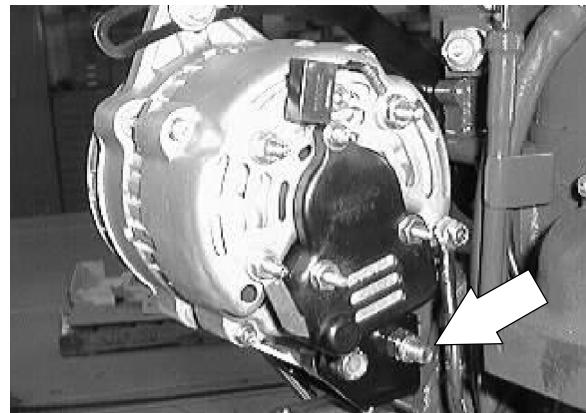

8. Push the alternator in toward the engine. Remove the V-belt from the alternator and engine pulleys.

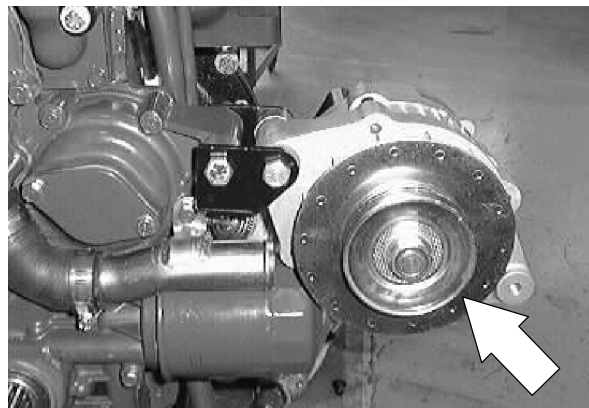

9. Disconnect the wires leading to the back of the alternator.

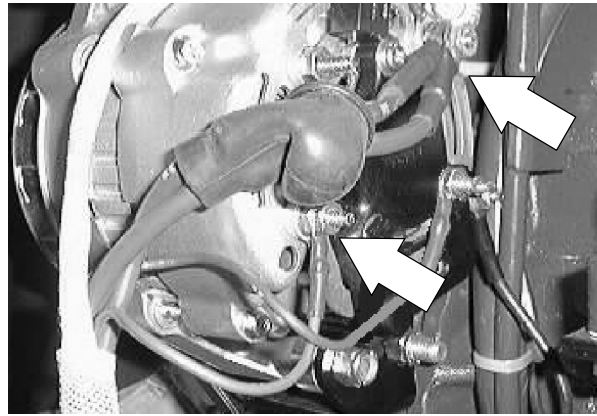

10. Remove the hex screw and nyloc nut holding the bottom of the alternator to the lower mount bracket.
11. The alternator can now be removed out the front of the machine.

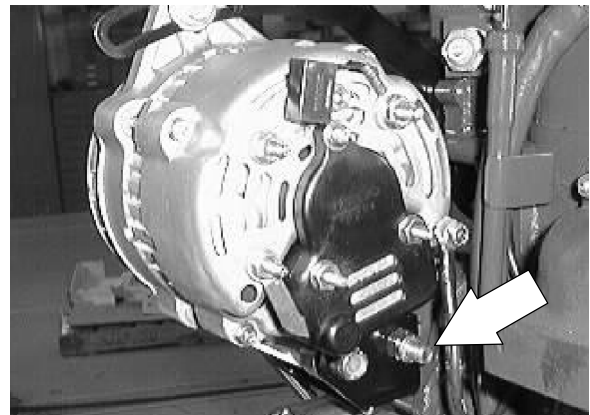

12. If the new or rebuilt alternator needs a drive pulley, remove the pulley from the old alternator. Hold the pulley from turning and use an impact wrench to remove the hex nut.
13. Install the pulley, washer, and hex nut on the new alternator. Firmly tighten the nut with the impact.



14. Install the new alternator back in the machine. Align the bottom hole in the alternator with hole in lower mount bracket. Reinstall the hex bolt, ground cable, and nyloc nut. Leave it loose for now.



15. Reconnect the wires to the back of alternator. See the schematic in the ELECTRICAL section.

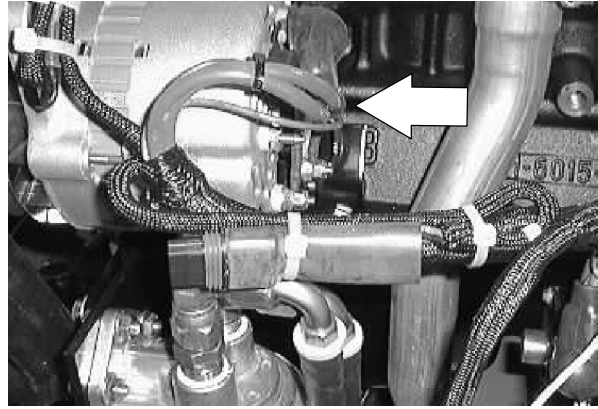

16. Place the V-belt back on the alternator pulley.

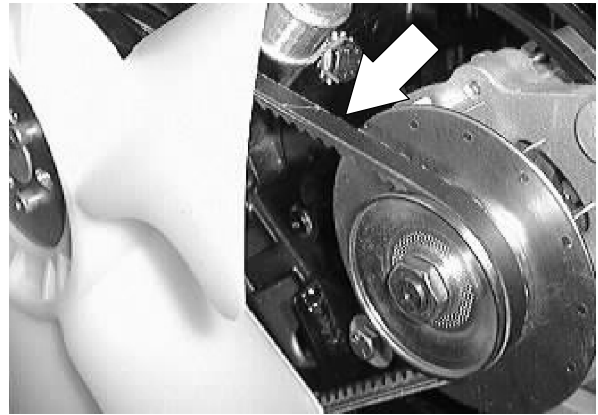

17. Reinstall the hex screw in the top hole of the alternator through upper slotted mounting bracket. Pull the alternator away from the engine to tighten the belt. See adjustment in ENGINE FAN BELT description. Tighten the hex screw to 18 - 24 Nm (13 - 18 ft lb).

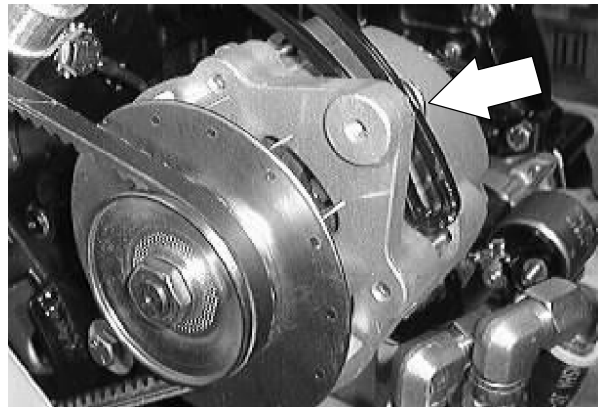

18. Tighten the bottom hex screw to 18 - 24 Nm (15 - 20 ft lb).

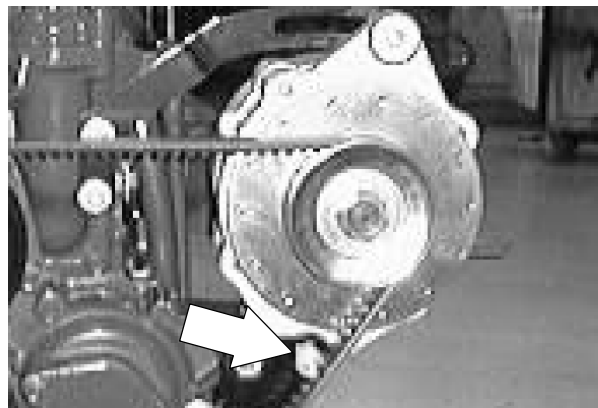

19. Place the rubber dust shield back in position.

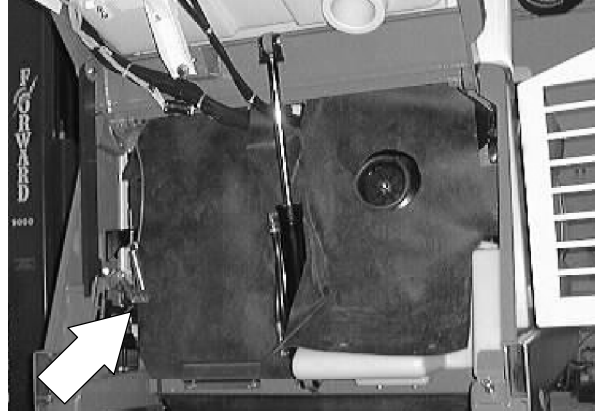

20. Reconnect the battery cables and start the engine. Check the new alternator for proper operation.

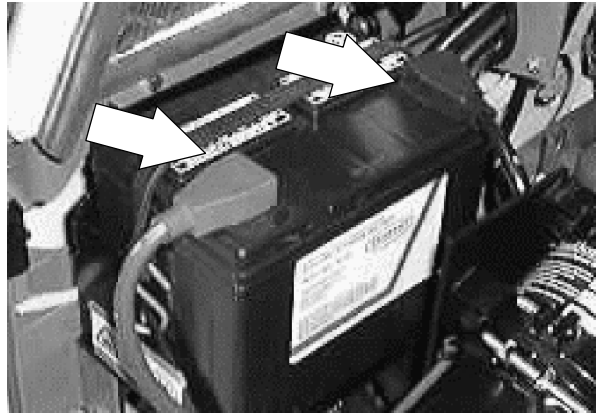

### TO REPLACE STARTER

**FOR SAFETY: Before Leaving Or Servicing Machine; Stop On Level Surface, Set Parking Brake, Turn Off Machine And Remove Key.**

1. Open the engine cover and side door.

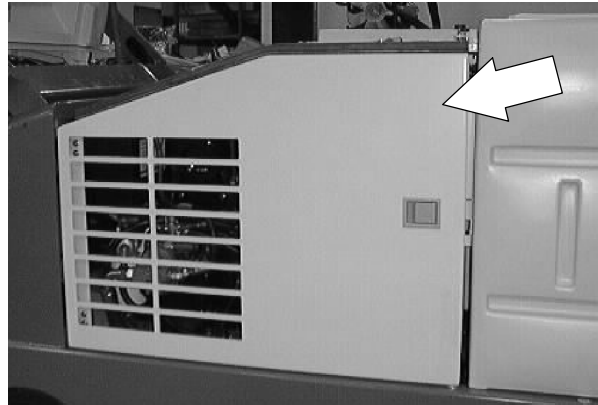

2. Disconnect the battery cables from the battery.

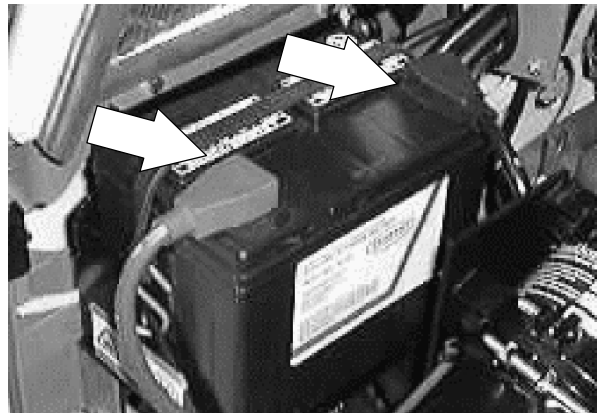

3. Disconnect the wires leading to the engine starter.



4. Remove the two M8 hex screws holding the starter to the engine bellhousing.

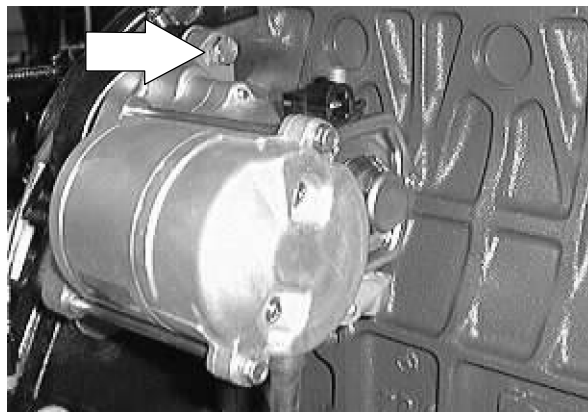

5. Pull the starter straight out of the bellhousing and remove it from the machine.



6. Install the new starter in the machine. Align the two holes in the starter with the holes in the bellhousing. Reinstall the two M8 hex screws. Tighten to 18 - 24 Nm (15 - 20 ft lb).

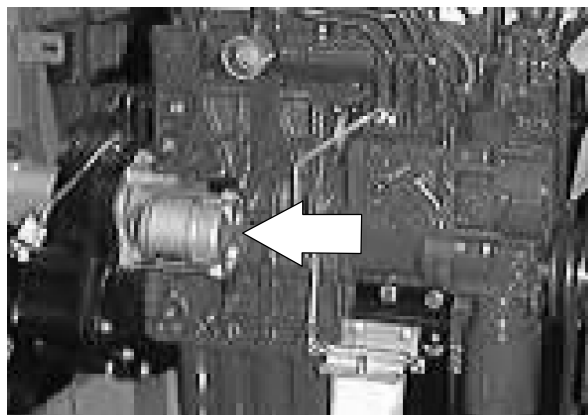

7. Reconnect the wires to the back of the starter. See the schematic in the ELECTRICAL section.



8. Reconnect the battery cables.

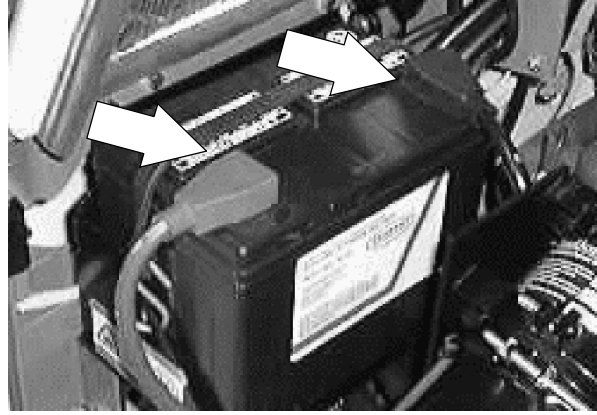

9. Close the engine cover and side door.  
Check the starter for proper operation.





**TO REMOVE ENGINE**

1. Raise the hopper and engage the prop bar.

**⚠ WARNING: Raised Hopper May Fall.  
Engage Hopper Support Bar.**

*NOTE: If the engine will not start because of a bad starter--use an overhead crane to lift the hopper and engage the prop arm.*

**FOR SAFETY: Before Leaving Or  
Servicing Machine; Stop On Level  
Surface, Set Parking Brake., Turn Off  
Machine And Remove Key.**

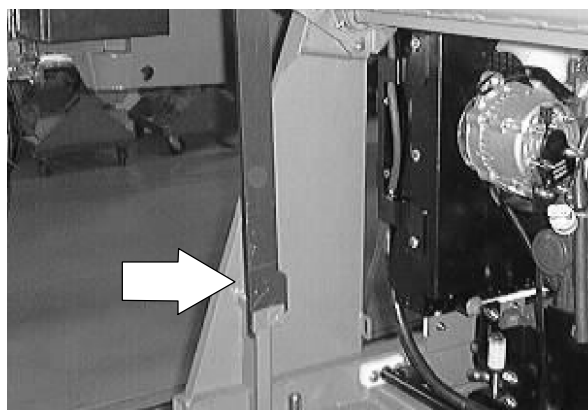

2. Open the engine cover and side door.

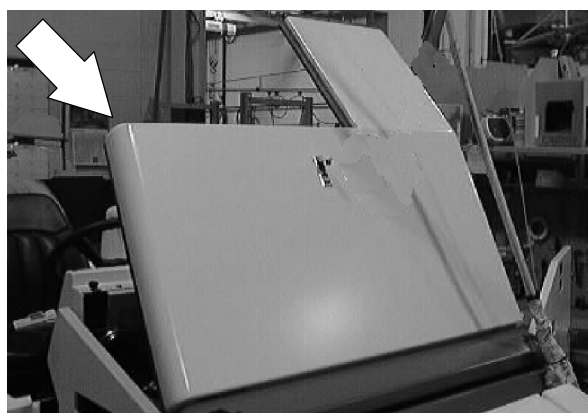

3. Remove the engine cover and side door from the machine.



4. Disconnect the battery cables from the battery. Remove the battery and battery tray from the machine.

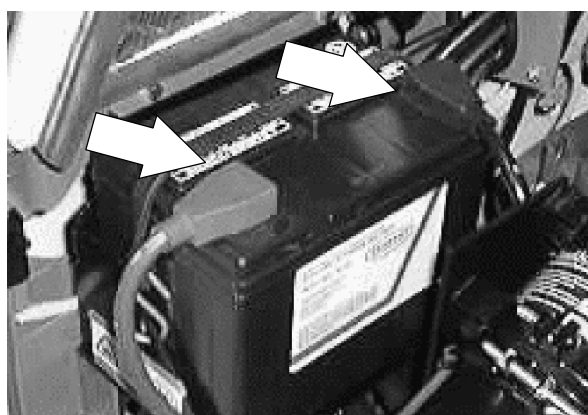

5. Remove the air cleaner and mount bracket from the engine.

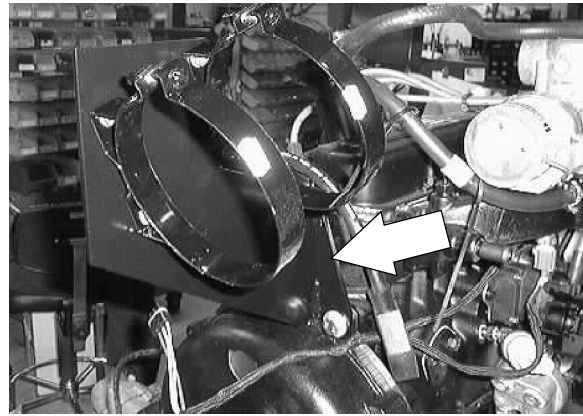

6. Pull the rubber dust shield up and out of the way for access to the front of the engine.

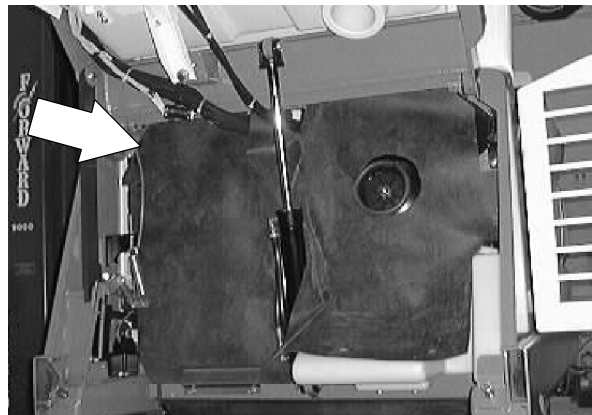

7. Disconnect the fuel tank lines at the injector pump and injector return line.

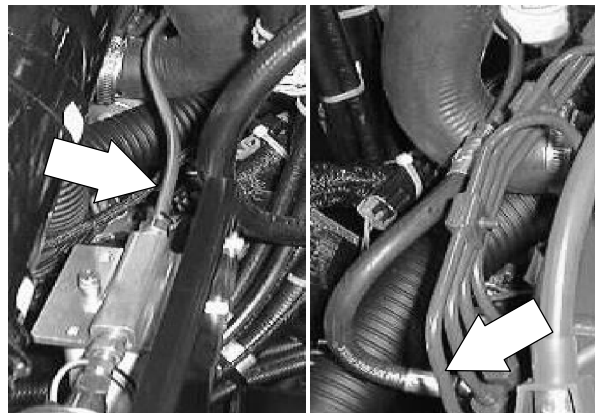

8. Remove the two hex screw holding the radiator grill guard to the frame. Remove the grill from the machine.

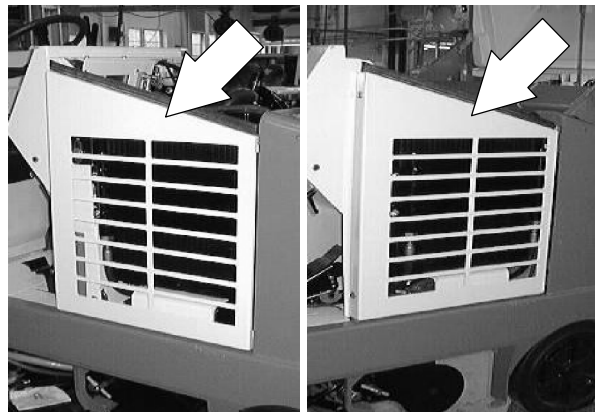

9. Mark, disconnect, and plug the two hydraulic hoses leading to the hydraulic oil cooler on the front of the radiator.

*NOTE: Always observe hydraulic cleanliness requirements when opening hydraulic lines.*

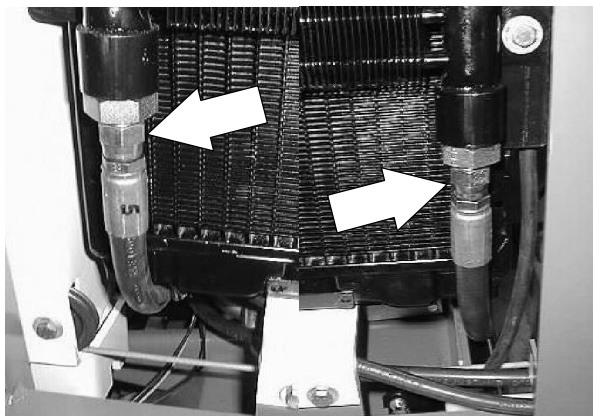

10. Drain the coolant from the radiator.



11. Remove the two radiator hoses from the engine.

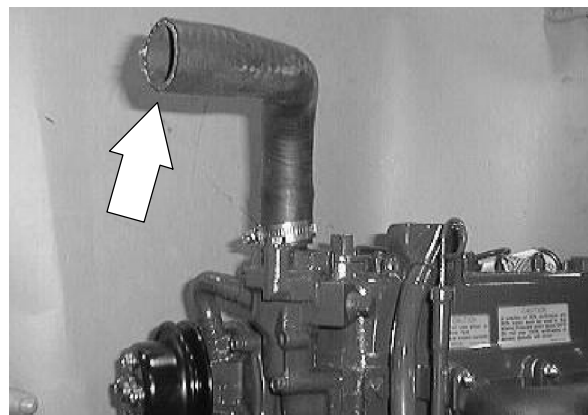

12. Remove the hex screw, spacer, and fender washer holding the top left side of the radiator to the radiator support.

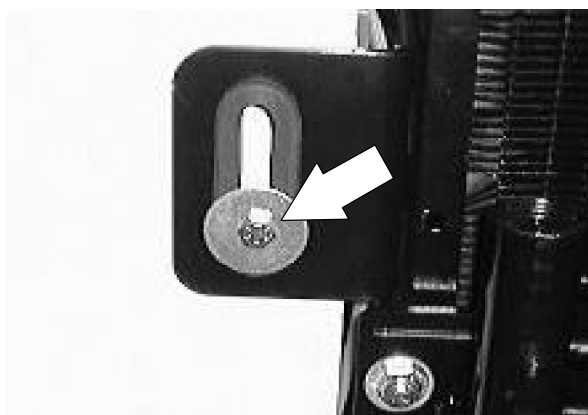

13. Remove the two hex screws and nyloc nuts holding the bottom of the radiator to the mount bracket.

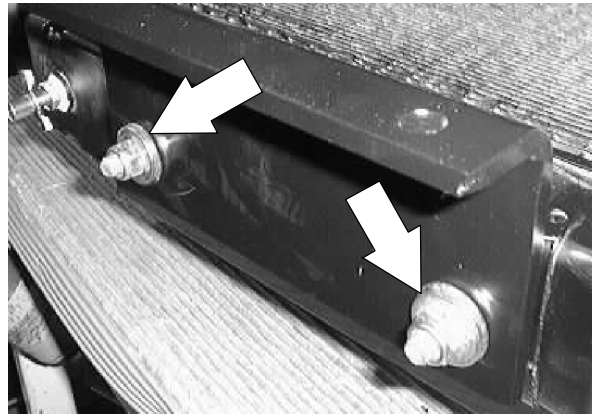

14. Pull the radiator back so it clears the engine fan. Remove the radiator, fan shroud, and hydraulic oil cooler from the machine.

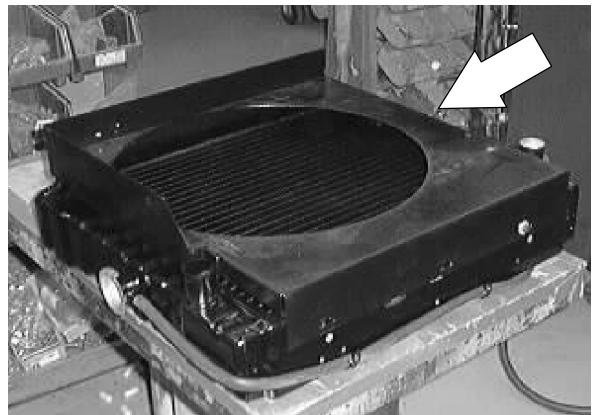

15. Remove the hex screw and compression spring from the front of the accessory pump pivot bracket. Remove the V-belt from the engine sheave.



16. Remove the hex screw, nut, and sleeve holding the hydraulic accessory pump pivot bracket to the front motor mount. Drop the hydraulic pump down onto the frame. DO NOT disconnect the hydraulic hoses leading to the accessory pump.

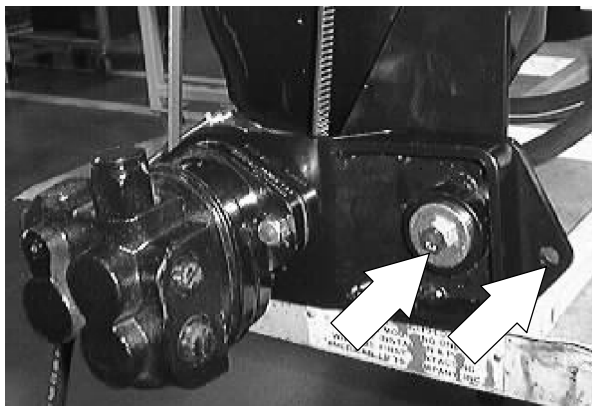

17. Remove the muffler clamp holding the exhaust pipe to the engine manifold. Slip the pipe off the manifold.

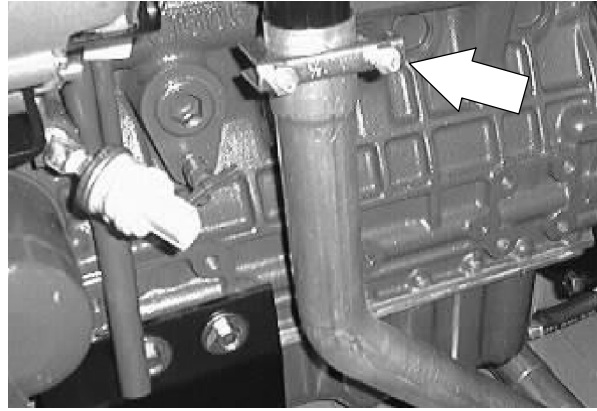

18. Disconnect the wire harness from the alternator, starter, oil sender, temp. sender, governor, glow plugs, mag. pick-up, ect. Move the wires out of the way for engine removal.



19. Disconnect the ground wires and ground cable from the rear motor mount hex screw.

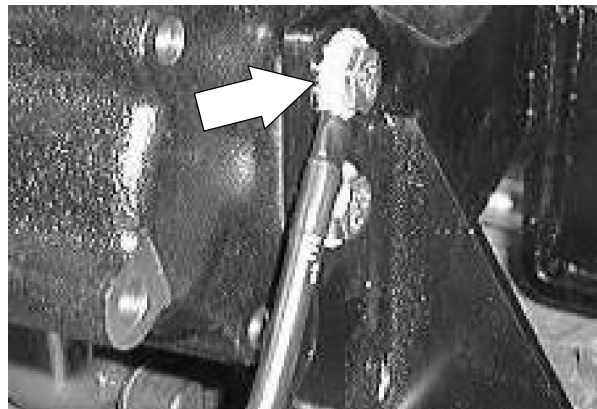

20. Loosen the jam nuts on the propel cable where it attaches to the mount bracket on the bellhousing. Pull the propel cable out of the mount bracket slot.

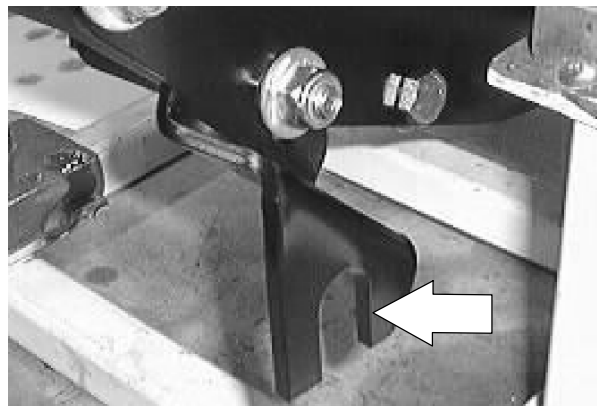

## ENG-DIESEL

21. Remove the two hex screws holding the propel pump into the flywheel housing.

*NOTE: Leave the hydraulic hoses connected to the propel pump.*

*NOTE: Place a block of wood under the hydraulic pump assembly for support when removing the engine.*

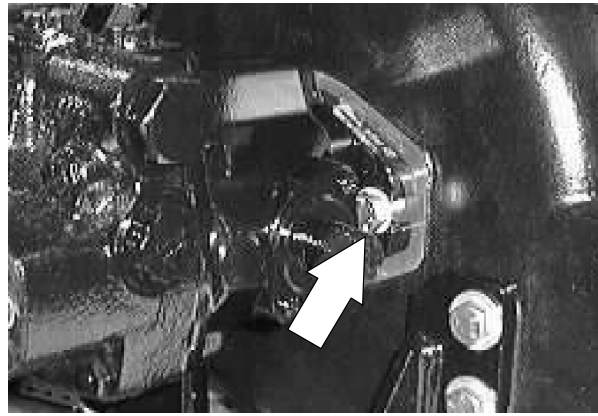

22. Pull the propel and accessory pump assembly back, out of the bellhousing.

*NOTE: Leave the hydraulic hoses connected to the propel pump.*

*NOTE: Pull the engine toward the right side of the machine until the hydraulic pump assembly is free of the bellhousing.*

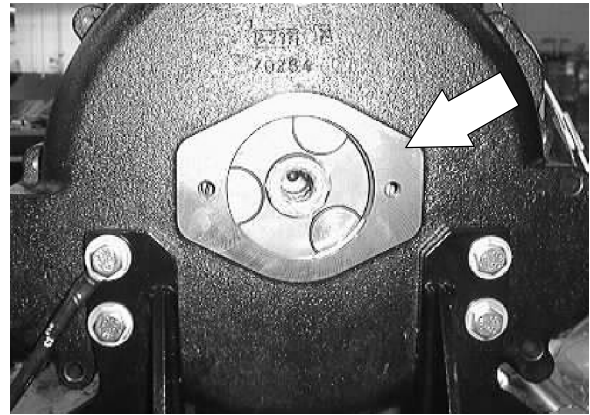

23. Using an overhead hoist, hook a chain through the two pick-up points on the top of the engine. Put a slight amount of tension on the chain.

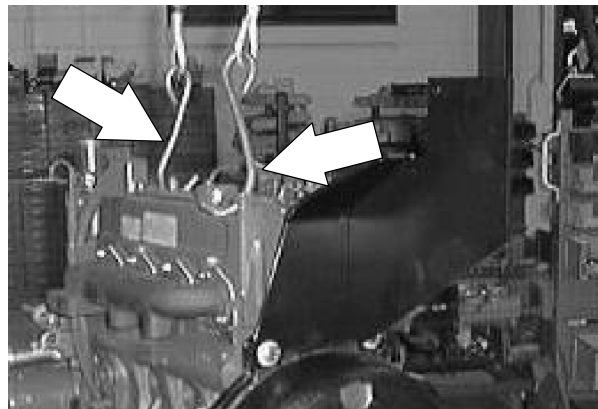

24. Remove the three hex screws and nyloc nuts holding the three motor mounts to the rubber isolators on the frame brackets.

25. The engine can now be carefully lifted out.

*NOTE: Make sure the engine is clear of any wires or hoses before you lift it out of the frame.*

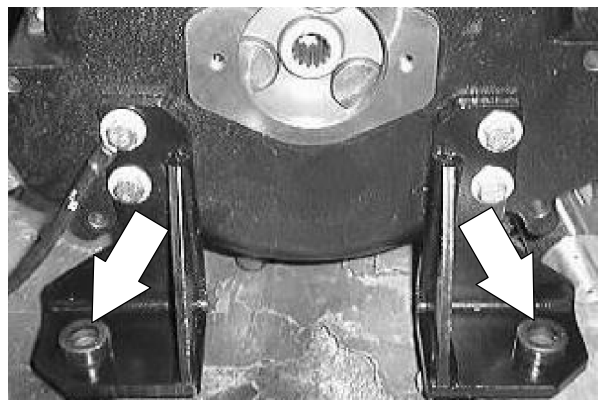

**TO INSTALL ENGINE**

**FOR SAFETY: Before Leaving Or Servicing Machine; Stop On Level Surface, Set Parking Brake., Turn Off Machine And Remove Key.**

1. Using an overhead hoist, hook a chain through the two pick-up points on top of the engine. Carefully position the engine back in the engine compartment.

*NOTE: Make sure the hoses, wire harness, exhaust pipe and propel pump are pulled back out of the way when lowering engine assembly into place.*

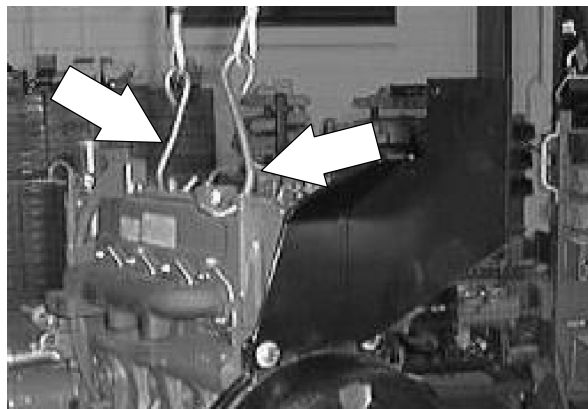

2. Slide the engine toward the left side of the machine until the propel pump is positioned into the back of the bellhousing. Install the two hex screws. Use a small amount of blue loctite 242 on the threads. Tighten the hardware to 37 - 48 Nm (26 - 34 ft lb).

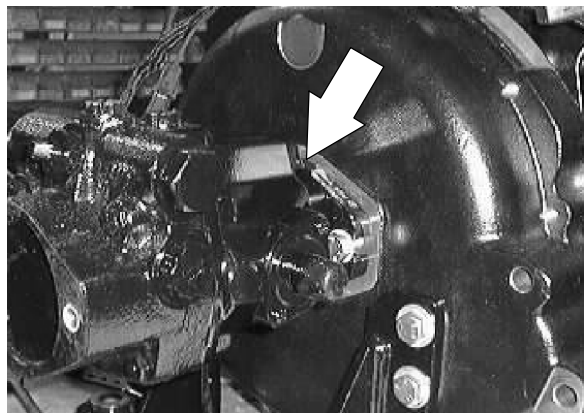

3. Carefully align the mount holes in the motor mounts with the mount holes in the machine frame.

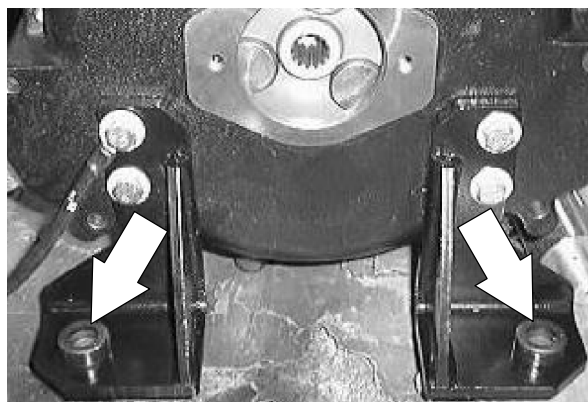

4. Reinstall the hex screws, washers, and nylocs in the three motor mounts. Lower the engine all the way. Remove the hoist from the engine. Tighten the hex screws to 64 - 83 Nm (47 - 61 ft lbs).

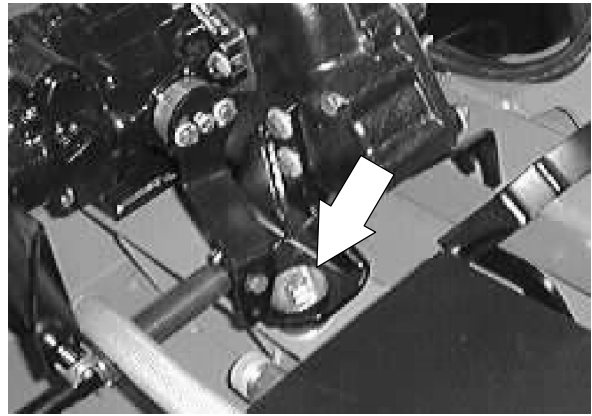

5. Position the propel cable into the slot on the bellhousing mount bracket.

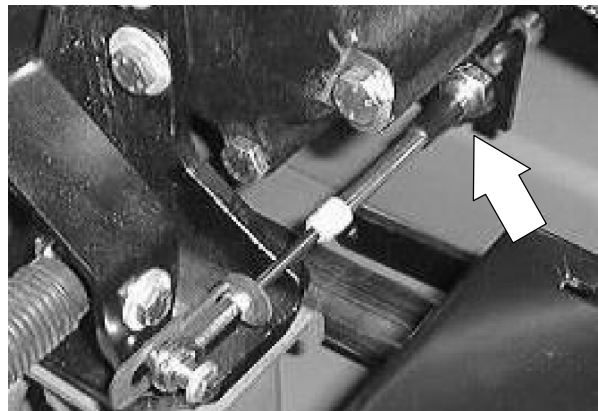

6. Reconnect the ground cable and ground wires to the rear motor mount hardware.

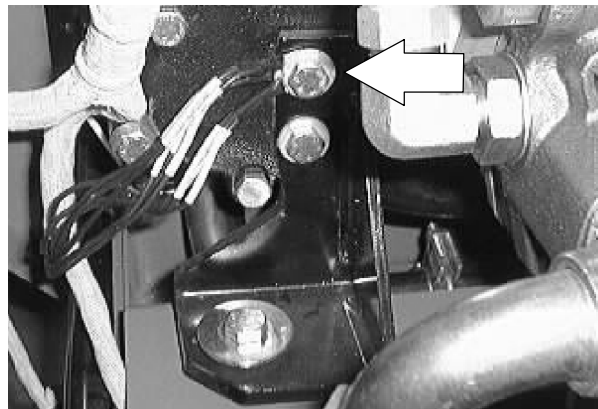

7. Reinstall the exhaust pipe back on the engine manifold. Tighten the muffler clamp tight.

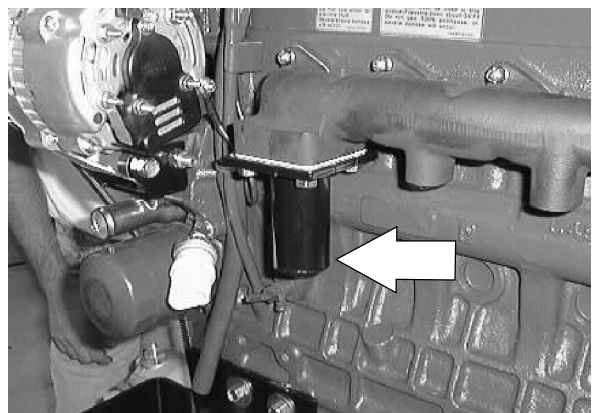



8. Reconnect the ground cable from the bellhousing to the machine frame.

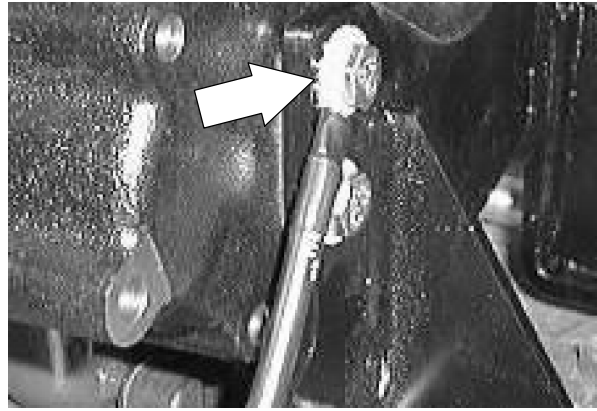

9. Reconnect fuel lines on the injector pump and return line.

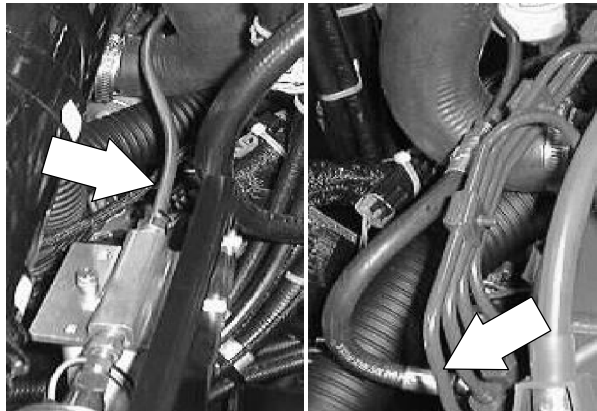

10. Fill the engine with the proper grade of oil. Use 6L (6.35 qt) of 10W30 SAE-CC/CD rated engine oil with a new filter.

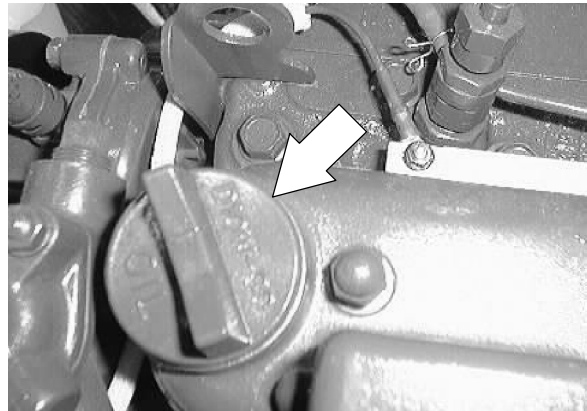

11. Reconnect the wire harness to the engine components; alternator, starter, governor actuator, oil switch, temperature sender, and glow plugs. Use the schematic in the ELECTRICAL section of this manual if needed.

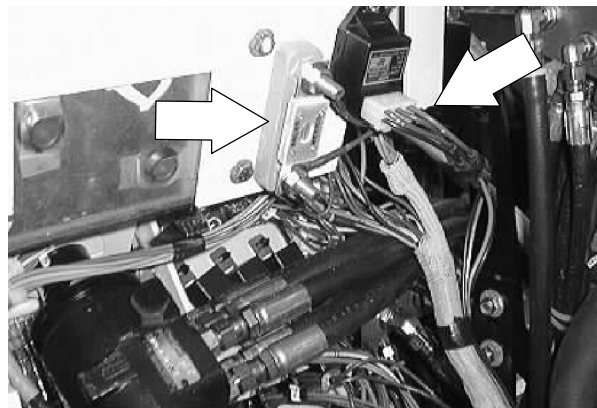

12. Reinstall the accessory pump and pivot bracket onto the motor mount. Tighten the hex screw to 37 - 48 Nm (26 - 34 ft lb).

*NOTE: Make sure the sleeve is in place.*

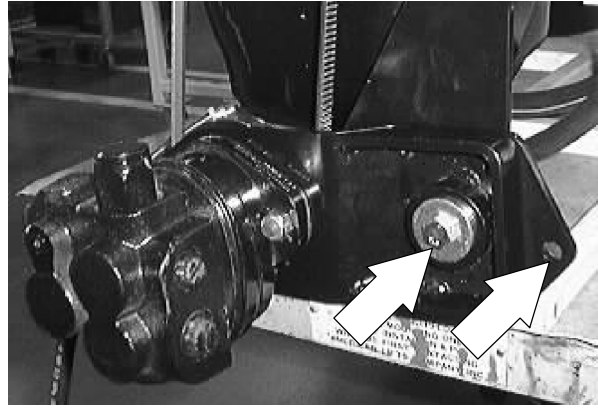

13. Position the accessory pump V-belt onto the engine sheave.

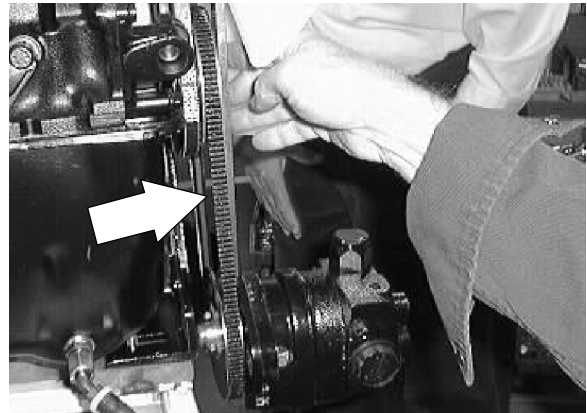

14. The accessory pump belt adjustment is made by turning the bolt on top of the tension spring. The tension spring is located at the front of the engine compartment, near the accessory pump belt sheave. The accessory pump belt is at the proper tension when the tension spring is compressed to 3.81 cm  $\pm$  0.0076 mm (1.5 in  $\pm$  0.030 in).

*NOTE: When adjusting the accessory pump belt tension, measure only the spring and not the washers at either end.*

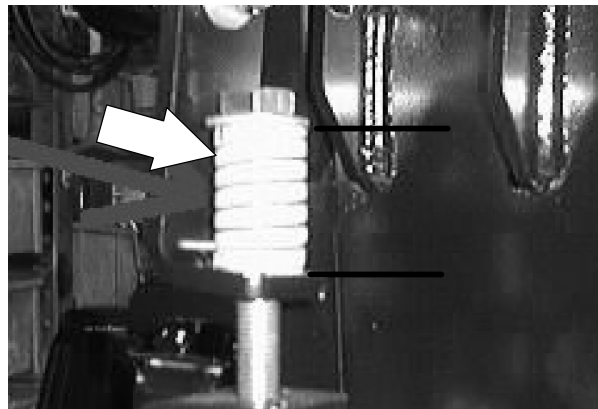

15. Position the radiator back in the machine. Align the two bottom studs on the radiator assembly with the isolators in the mount bracket. Reinstall the two 0.375 nyloc nuts and washers. Lightly hand tighten.

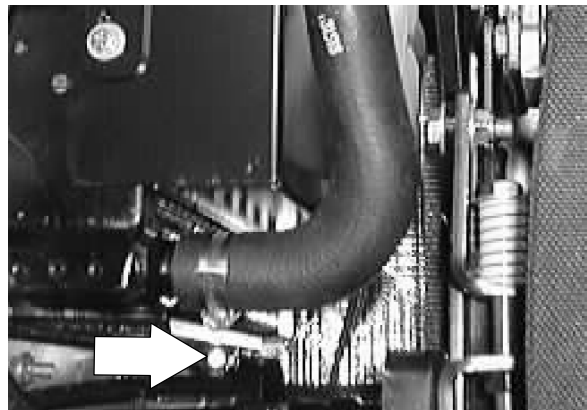

16. Reinstall the hex screw and fender washer holding the top of the radiator to the radiator support. Tighten to 6 - 9 Nm (7 - 10 ft lb). Go back and tighten the two hex screws on the bottom of the mount bracket. Tighten to 37 - 48 Nm (26 - 34 ft lb).

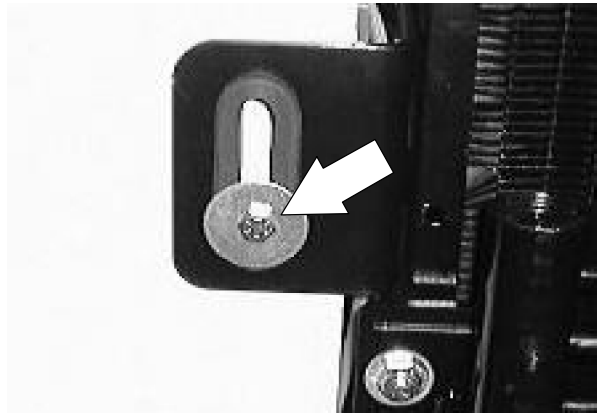

17. Reinstall the radiator hoses to engine and fill the radiator with coolant.

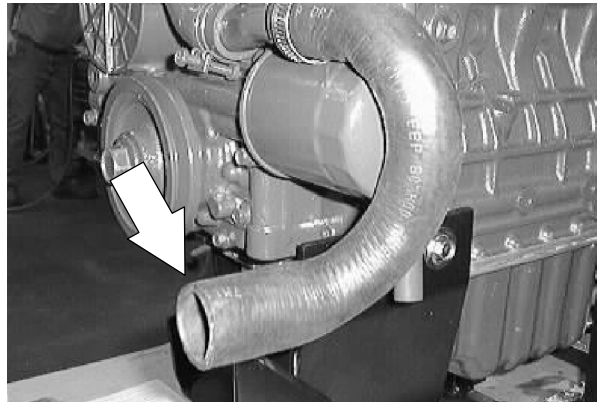

18. Reconnect the two hydraulic hoses to the hydraulic oil cooler on the front of the radiator.

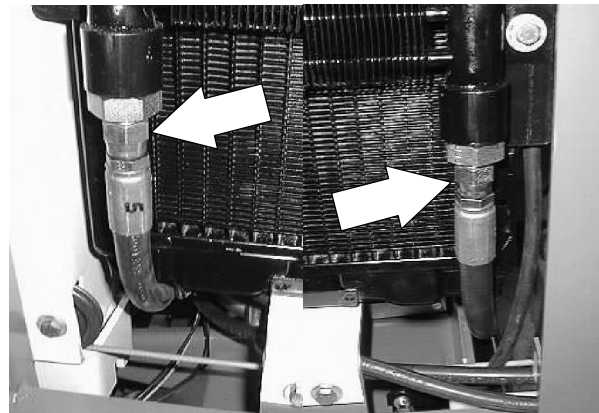

19. Reinstall the radiator grill guard.

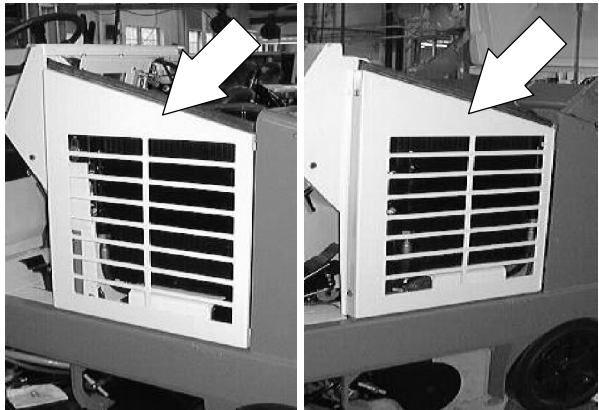

20. Reinstall the air cleaner mount bracket and air cleaner assembly on the rear of the bellhousing. Use the two M10 hex screws. Tighten to 37 - 48 Nm (26 - 34 ft lb).

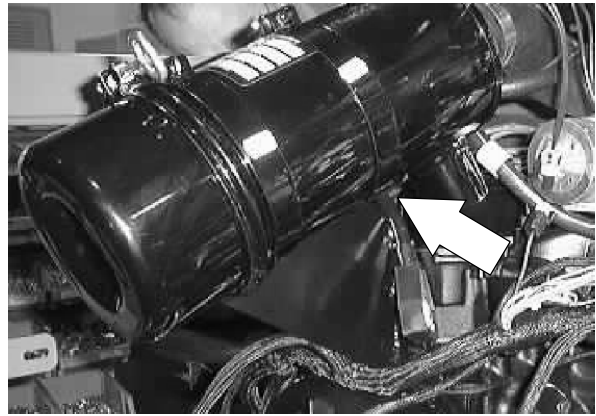

21. Reinstall the battery tray and battery.

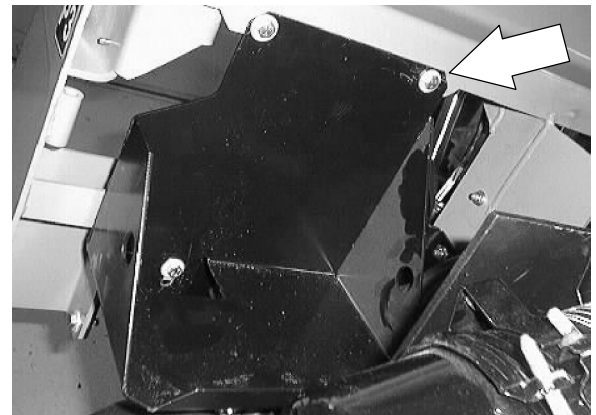

22. Reconnect the battery cables to the battery.

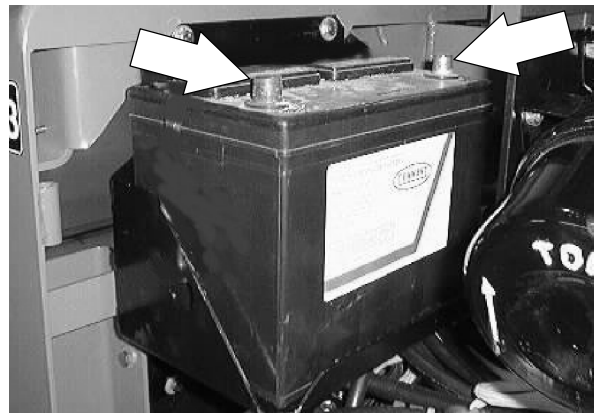

23. Jack up the rear of the machine.

**FOR SAFETY: Block machine tires before jacking machine up. Jack machine up at designated locations only. Block machine up with jack stands.**



24. Start the engine and check for any leaks and proper operation.

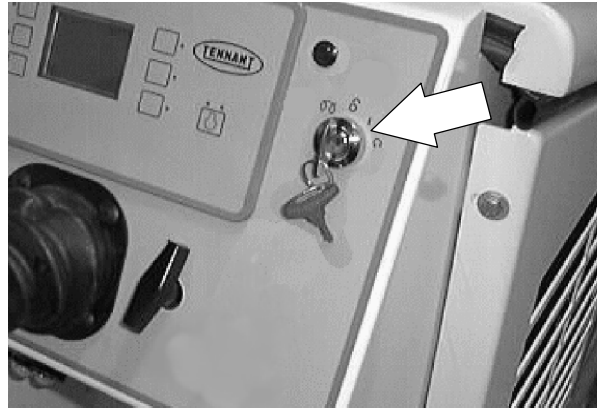

25. Reinstall the engine cover and side door.



26. Reinstall the front rubber firewall.

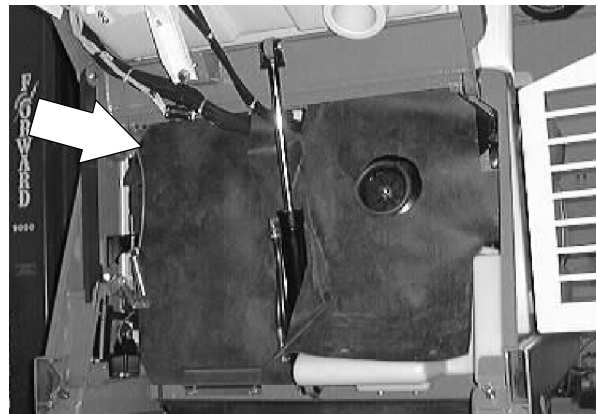







**TENNANT COMPANY**  
 Technical Publications #15  
 701 North Lilac Drive  
 P.O. Box 1452  
 Minneapolis, MN 55440-9947

POSTAGE WILL BE PAID BY ADDRESSEE

**BUSINESS REPLY MAIL**  
 FIRST CLASS MAIL PERMIT NO. 94 MINNEAPOLIS, MN



NO POSTAGE  
 NECESSARY  
 IF MAILED  
 IN THE  
 UNITED STATES

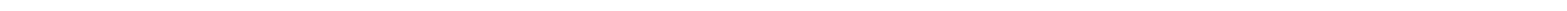

Fold along dotted lines

Tape here









**TENNANT COMPANY**  
 Technical Publications #15  
 701 North Lilac Drive  
 P.O. Box 1452  
 Minneapolis, MN 55440-9947

POSTAGE WILL BE PAID BY ADDRESSEE

**BUSINESS REPLY MAIL**  
 FIRST CLASS MAIL PERMIT NO. 94 MINNEAPOLIS, MN



NO POSTAGE  
 NECESSARY  
 IF MAILED  
 IN THE  
 UNITED STATES

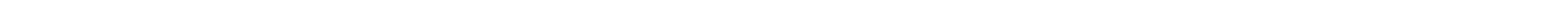
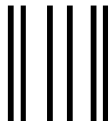

Fold along dotted lines

Tape here

