

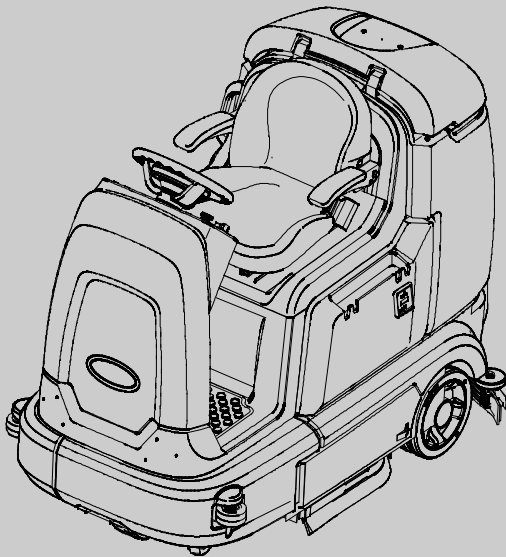

T12

(Battery)

Rider Scrubber Service Information Manual



The Safe Scrubbing Alternative®
TennantTrue® Parts
IRIS™ a Tennant Technology



North America / International



To view, print or download
the latest parts or operator's
manual, visit:
www.tennantco.com/manuals

9009917
Rev. 00 (12-2012)



INTRODUCTION



This manual provides necessary service and maintenance instructions.



Read this manual completely and understand the machine before servicing it.

This machine will provide excellent service. However, the best results will be obtained at minimum costs if:

- The machine is operated with reasonable care.
- The machine is maintained regularly - per the machine maintenance instructions provided.
- The machine is maintained with manufacturer supplied or equivalent parts.

 	<p>PROTECT THE ENVIRONMENT</p> <p>Please dispose of packaging materials, old machine components and fluids in an environmentally safe way according to local waste disposal regulations.</p> <p>Always remember to recycle.</p>	<p>MACHINE DATA</p> <p>Please fill out at time of installation for future reference.</p> <p>Model No. - _____</p> <p>Serial No. - _____</p> <p>Installation Date - _____</p>
--	--	---

INTENDED USE

The T12 is an industrial/commercial rider machine designed to wet scrub both rough and smooth hard surfaces (concrete, tile, stone, synthetic, etc). Typical applications include schools, hospitals / health care facilities, office buildings, and retail centers. Do not use this machine on soil, grass, artificial turf, or carpeted surfaces. This machine is intended for indoor use only. This machine is not intended for use on public roadways.

Tennant Company

PO Box 1452

Minneapolis, MN 55440

Phone: (800) 553-8033 or (763) 513-2850

www.tennantco.com

Touch-N-Go, 1-STEP, Grip-N-Go, Dura-Track, SmartRelease, Duramer, are US registered and unregistered trademarks of Tennant Company.

Flow-Rite is a registered trademark of Flow-Rite Controls

Specifications and parts are subject to change without notice.

Original Instructions, copyright © 2013 TENNANT Company, Printed in U.S.A.

Contents	Page
SAFETY PRECAUTIONS	1-1
GENERAL INFORMATION	2-1
COMPONENT LOCATOR	2-2
ELECTRICAL SCHEMATIC, MASTER	2-4
ELECTRICAL SCHEMATIC SYMBOLS	2-9
OPERATIONAL MATRIX	2-10
SPECIFICATIONS	2-12
FASTENER TORQUE	2-12
MACHINE DIMENSIONS	2-13
GENERAL MACHINE DIMENSIONS/ CAPACITIES	2-14
GENERAL MACHINE PERFORMANCE ...	2-14
POWER TYPE	2-15
TIRES	2-15
EC-H2O SYSTEM (OPTION)	2-15
ELECTRICAL COMPONENTS	2-16
MAINTENANCE	
MAINTENANCE CHART	3-2
LUBRICATION	3-4
BATTERIES	3-5
CHARGING THE BATTERIES (OFF-BOARD CHARGER)	3-6
CHARGING THE BATTERIES (ON-BOARD CHARGER)	3-7
ON-BOARD CHARGER ERROR CODES ...	3-8
ON-BOARD CHARGER SETTINGS	3-9
CHANGING THE ON-BOARD BATTERY CHARGER FUSE	3-10
FLOW-RITE™ BATTERY WATERING SYSTEM	3-11
CIRCUIT BREAKERS	3-13
ELECTRIC MOTORS	3-14
SCRUB BRUSHES	3-15
DISK BRUSHES AND PADS	3-15
REPLACING DISK BRUSHES (OR PAD DRIVERS)	3-15
REPLACING DISK SCRUB PADS	3-16
CYLINDRICAL BRUSHES	3-17
REPLACING CYLINDRICAL BRUSHES	3-17
CHECKING CYLINDRICAL SCRUB BRUSH PATTERN	3-18
ADJUSTING CYLINDRICAL BRUSH TAPER	3-21
ADJUSTING CYLINDRICAL BRUSH PATTERN WIDTH	3-22
SIDE BRUSH (OPTION)	3-23
REPLACING THE SIDE BRUSH	3-23
SQUEEGEE BLADES	3-24
REPLACING OR ROTATING THE	

Contents	Page
REAR SQUEEGEE BLADES	3-24
LEVELING THE REAR SQUEEGEE	3-27
ADJUSTING THE REAR SQUEEGEE BLADE DEFLECTION	3-28
REPLACING OR ROTATING THE SIDE SQUEEGEE BLADES	3-29
REPLACING OR ROTATING THE SIDE BRUSH SQUEEGEE BLADES (OPTION)	3-30
SKIRTS AND SEALS	3-31
BELTS	3-31
TIRES	3-31
PUSHING, TOWING, AND TRANSPORTING THE MACHINE	3-33
MACHINE JACKING	3-35
ec-H2O MODULE FLUSH PROCEDURE	3-36
STORAGE INFORMATION	3-38
FREEZE PROTECTION	3-38
PREPARING THE MACHINE FOR OPERATION AFTER STORAGE	3-40
PRIMING THE EC-H2O SYSTEM	3-42
TROUBLESHOOTING	
ONBOARD DIAGNOSTICS	4-2
SELF-TEST MODE	4-2
CONFIGURATION MODE	4-4
LCD WARNINGS	4-6
LCD FAULTS	4-7
PROPEL DIAGNOSTIC MODE	4-9
CURTIS 1232 CONTROLLER DIAGNOSTICS	4-11
DIAGNOSTIC LED OPERATION	4-11
DIAGNOSTIC CODES	4-12
INPUT DISPLAY MODE	4-20
MANUAL MODE	4-22
CAN (CONTROLLER AREA NETWORK) DIAGNOSTIC MODE	4-24
FIRMWARE UPDATE MODE	4-25
BATTERY CHARGER, STANDARD	4-26
OPERATION	4-26
CONFIGURATION	4-26
FAULTS	4-26
BATTERY CHARGER, ONBOARD OPT. ...	4-27
OPERATION	4-27
CONFIGURATION	4-27
FAULTS	4-27
SUBSYSTEM TROUBLESHOOTING	4-28
BACK-UP ALARM/LIGHT	4-28
BATTERY CHARGING	4-30
ONBOARD	4-30
OFF BOARD	4-32
PARKING BRAKE, ELECTROMAGNETIC ..	4-34
LIGHTING	4-36

CONTENTS

Contents	Page
MAIN SCRUB BRUSHES	4-38
POWER-UP	4-40
PROPEL	4-42
REAR SQUEEGEE LIFT	4-44
SCRUB HEAD LIFT	4-46
SIDE BRUSH	4-48
SIDE BRUSH LIFT	4-50
SOLUTION CONTROL, CONVENTIONAL	4-54
MAIN BRUSH	4-54
SIDE BRUSH	4-56
SOLUTION CONTROL, ECH2O	4-58
SPRAY NOZZLE	4-60
VACUUM FAN	4-62
SERVICE	
SERVICE PROCEDURES	5-2
REAR SQUEEGEE LIFT ACTUATOR	5-2
REMOVAL	5-2
INSTALLATION	5-3
SIDE BRUSH LIFT ACTUATOR	5-4
REMOVAL	5-4
INSTALLATION	5-4
ADJUSTING SIDE BRUSH	
SPRING TUBE ASSEMBLY	5-5
SIDE BRUSH MOTOR	5-6
REMOVAL	5-6
INSTALLATION	5-7
CARBON BRUSHES	5-7
MAIN BRUSH LIFT ACTUATOR	5-8
REMOVAL	5-8
INSTALLATION	5-8
MAIN SCRUB HEAD	5-9
REMOVAL	5-9
INSTALLATION	5-10
MAIN SCRUB BRUSH MOTOR	
(CYLINDRICAL)	5-11
REMOVAL	5-11
INSTALLATION	5-12
CARBON BRUSHES	5-12
INSTRUMENT PANEL	5-13
REMOVAL	5-13
INSTALLATION	5-13
LOGIC BOARD REPLACEMENT	5-14
REMOVAL	5-14
INSTALLATION	5-15
STEERING WHEEL TIMING	5-16
WHEEL DRIVE ASSEMBLY	5-17
REMOVAL	5-17
INSTALLATION	5-18
TIRE REPLACEMENT	5-19

Contents	Page
VACUUM FAN ASSEMBLY	5-20
REMOVAL	5-20
INSTALLATION	5-21
COMPONENT TESTING	5-22
TANK LEVEL SENSORS	5-22
PARKING BRAKE, ELECTROMAGNETIC ..	5-24
PROPEL MOTOR (AND ENCODER)	5-27
PROPEL MOTOR CABLES	5-29
THROTTLE/BRAKE SENSOR	5-31
SIDE BRUSH LIFT ACTUATOR	5-33
MAIN BRUSH LIFT ACTUATOR	5-34
COMPONENT TESTING (CONTINUED)	
REAR SQGE LIFT ACTUATOR	5-35
VACUUM FAN	5-36
MAIN SCRUB BRUSH MOTORS	5-37
SIDE BRUSH MOTOR	5-38
EC-H2O PUMP	5-39
EC-H2O PRESSURE SWITCH	5-40

SAFETY PRECAUTIONS

IMPORTANT SAFETY INSTRUCTIONS - SAVE THESE INSTRUCTIONS

The following precautions are used throughout this manual as indicated in their description:

 **WARNING: To warn of hazards or unsafe practices that could result in severe personal injury or death.**

FOR SAFETY: To identify actions that must be followed for safe operation of equipment.

The following information signals potentially dangerous conditions to the operator. Know when these conditions can exist. Locate all safety devices on the machine. Report machine damage or faulty operation immediately.

 **WARNING: Batteries emit hydrogen gas. Explosion or fire can result. Keep sparks and open flame away. Keep covers open when charging.**

 **WARNING: Flammable materials can cause an explosion or fire. Do not use flammable materials in tank(s).**

 **WARNING: Flammable materials or reactive metals can cause an explosion or fire. Do not pick up.**

 **WARNING: Electrical Hazard**

- Disconnect Battery Cables and Charger Plug Before Servicing Machine.
- Do Not Charge Batteries with Damaged Power Supply Cord. Do Not Modify Plug.

If the charger supply cord is damaged or broken, it must be replaced by the manufacturer or its service agent or a similarly qualified person in order to avoid a hazard.

FOR SAFETY:

1. Do not operate machine:
 - Unless trained and authorized.
 - Unless operator manual is read and understood.
 - Under the influence of alcohol or drugs
 - While using a cell phone or other types of electronic devices
 - Unless mentally and physically capable of following machine instructions.
 - With brake disabled.
 - If it is not in proper operating condition.
 - In areas where flammable vapors/liquids or combustible dusts are present.
 - In areas that are too dark to safely see the controls or operate the machine unless operating / headlights are turned on.
 - In areas with possible falling objects unless equipped with overhead guard.
2. Before starting machine:
 - Check machine for fluid leaks.
 - Keep sparks and open flame away from refueling area.
 - Make sure all safety devices are in place and operate properly.
 - Check brakes and steering for proper operation.
 - Adjust seat and fasten seat belt (if equipped).
3. When using machine:
 - Use only as described in this manual.
 - Use brakes to stop machine.
 - Go slowly on inclines and slippery surfaces.
 - Reduce speed when turning.
 - Keep all parts of body inside operator station while machine is moving.
 - Use care when reversing machine.
 - Never allow children to play on or around machine.
 - Do not carry passengers on machine.
 - Always follow safety and traffic rules.
 - Report machine damage or faulty operation immediately.
 - Follow mixing, handling and disposal instructions on chemical containers.
 - Follow safety guidelines concerning wet floors.

SAFETY PRECAUTIONS

SAFETY PRECAUTIONS

4. Before leaving or servicing machine:
 - Stop on level surface.
 - Turn off machine and remove key.
5. When servicing machine:
 - All work must be done with sufficient lighting and visibility.
 - Avoid moving parts. Do not wear loose clothing, jewelry and secure long hair.
 - Block machine tires before jacking machine up.
 - Jack machine up at designated locations only. Support machine with jack stands.
 - Use hoist or jack that will support the weight of the machine.
 - Do not push or tow the machine on inclines with the brake disabled.
 - Do not power spray or hose off machine near electrical components.
 - Disconnect battery connections before working on machine.
 - Avoid contact with battery acid.
 - All repairs must be performed by a trained service mechanic.
 - Do not modify the machine from its original design.
 - Use Tennant supplied or approved replacement parts.
 - Wear personal protective equipment as needed and where recommended in this manual.
6. When loading/unloading machine onto/off truck or trailer.
 - Drain tanks before loading machine.
 - Lower scrub head and squeegee before tying down machine.
 - Turn off machine and remove key.
 - Use ramp, truck or trailer that will support the weight of the machine and operator.
 - Use winch. Do not push the machine onto/off the truck or trailer unless the load height is 380 mm (15 in) or less from the ground.
 - Block machine tires.
 - Tie machine down to truck or trailer.



For Safety: wear hearing protection.



For Safety: wear protective gloves.



For Safety: wear eye protection.



For Safety: wear protective dust mask.

SAFETY PRECAUTIONS

The safety labels appear on the machine in the locations indicated. Replace damaged labels.

WARNING LABEL - Flammable materials or reactive metals can cause explosion or fire. Do not pick up.



Located on electrical panel.

WARNING LABEL - Flammable materials can cause explosion or fire. Do not use flammable materials in tank

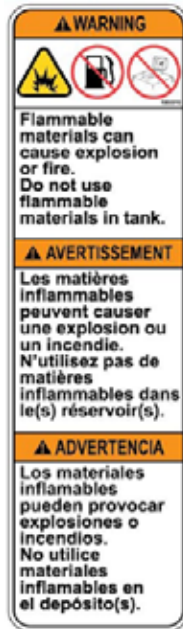

Located on recovery tank, above solution tank cap.

WARNING LABEL - Batteries emit hydrogen gas. Explosion or fire can result. Keep sparks and open flame away. Keep covers open when charging



Located inside battery compartment.

FOR SAFETY LABEL - Read manual before operating machine.



Located on electrical panel.

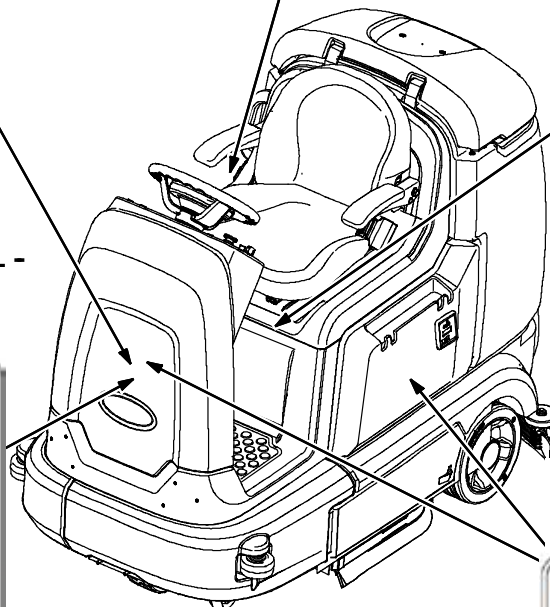

FOR SAFETY LABEL - Authorized Service Mechanic Only.



Located on circuit board cover and electrical panel.

SAFETY PRECAUTIONS

SECTION 2

Contents	Page
GENERAL INFORMATION	2-1
COMPONENT LOCATOR.....	2-2
ELECTRICAL SCHEMATIC, MASTER	2-4
ELECTRICAL SCHEMATIC SYMBOLS	2-9
OPERATIONAL MATRIX.....	2-10
SPECIFICATIONS.....	2-12
FASTENER TORQUE	2-12
MACHINE DIMENSIONS.....	2-13
GENERAL MACHINE DIMENSIONS/ CAPACITIES	2-14
GENERAL MACHINE PERFORMANCE ...	2-14
POWER TYPE	2-15
TIRES	2-15
EC-H2O SYSTEM (OPTION).....	2-15
ELECTRICAL COMPONENTS.....	2-16

GENERAL INFORMATION

COMPONENT LOCATOR

Components	
A	ec-H2O System Components*
B	IRIS™ Inline 2 Amp Fuse Holder*
C	ec-H2O, Side Brush, and Spray Nozzle Pumps*
D	Batteries
E	SV-3 Side Brush Water Valve*
F	Wheel Drive Assembly (Motor, Encoder, Temp Sender)
G	Seat Switch
H	Circuit Breakers (1-8)
I	Warning Light/ Backup Alarm*
J	Solution Tank
K	Vacuum Fan Housing
L	Rear Squeegee Lift Actuator Level Switch, Solution Tank
M	SV-2 Main Water Valve
N	Side Brush Motor*
O	Throttle/Brake Sensor
P	Circuit Breakers (9-16)
P ₁	Module, Side Scrub
Q	Module, Curtis 1232
R	Recovery Tank

* Optional Equipment



COMPONENT LOCATOR, continued

Components	
S	Module, Main Scrub
T	Module, Interface
U	Module, IRIS™ Telemetry
V	Main Scrub Head Lift Actuator
W	Module, Water Pickup Diodes 1, 2, and 3
X	Onboard Battery Charger
Y	M2 Relay, Circuit Breaker 17 (Inside Warning Light/BU Alarm)
Z	Level Switch, Recovery Tank

* Optional Equipment

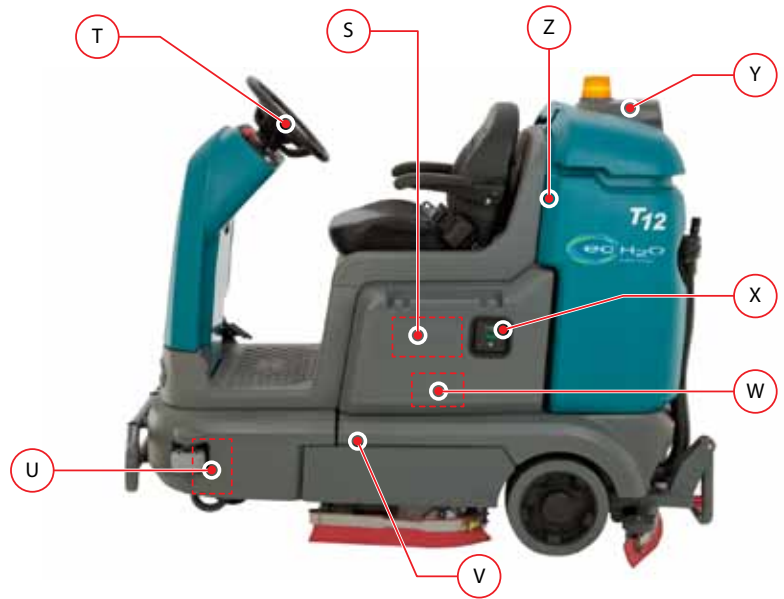

ELECTRICAL SCHEMATIC (2 of 6)

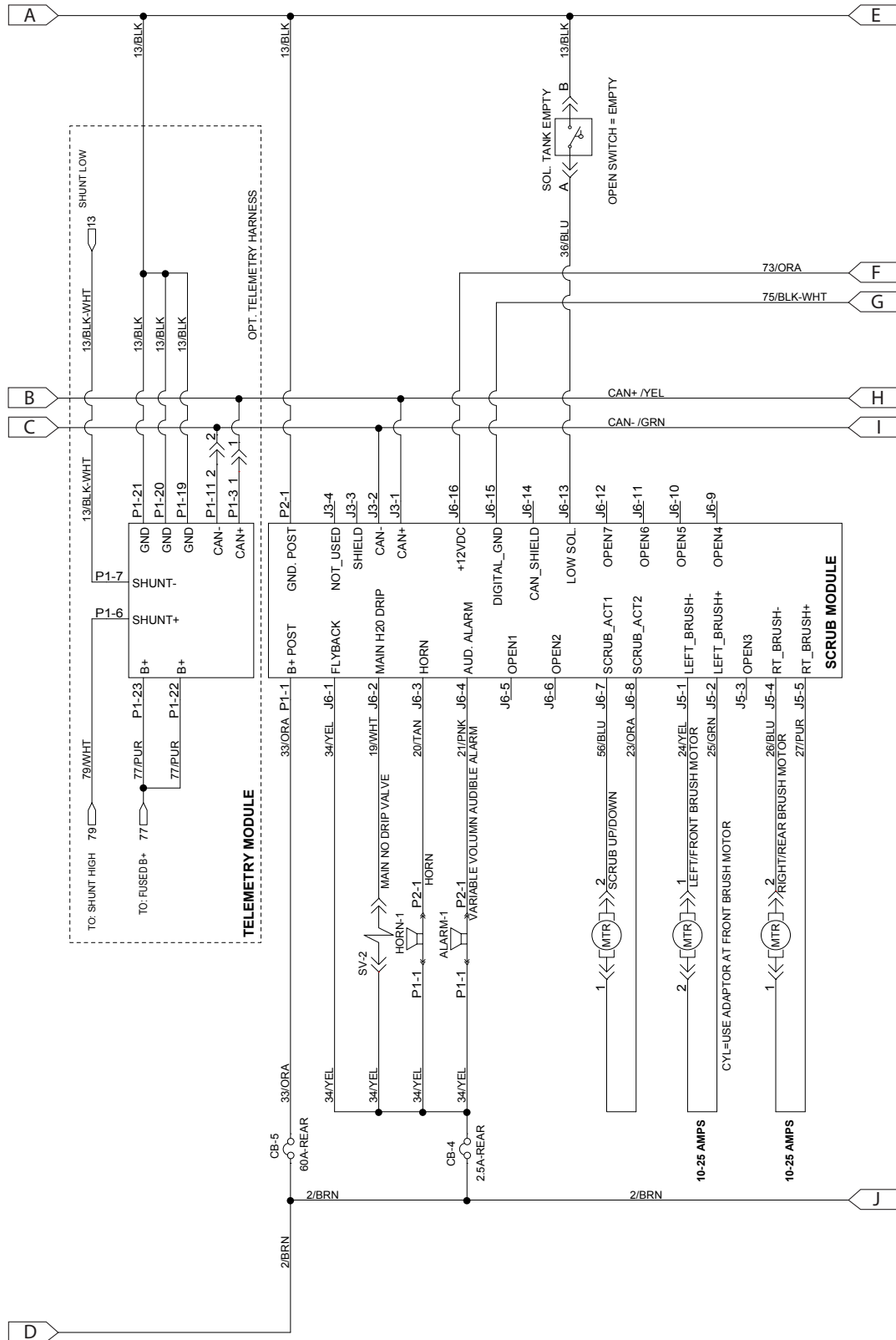

GENERAL INFORMATION

ELECTRICAL SCHEMATIC (3 of 6)

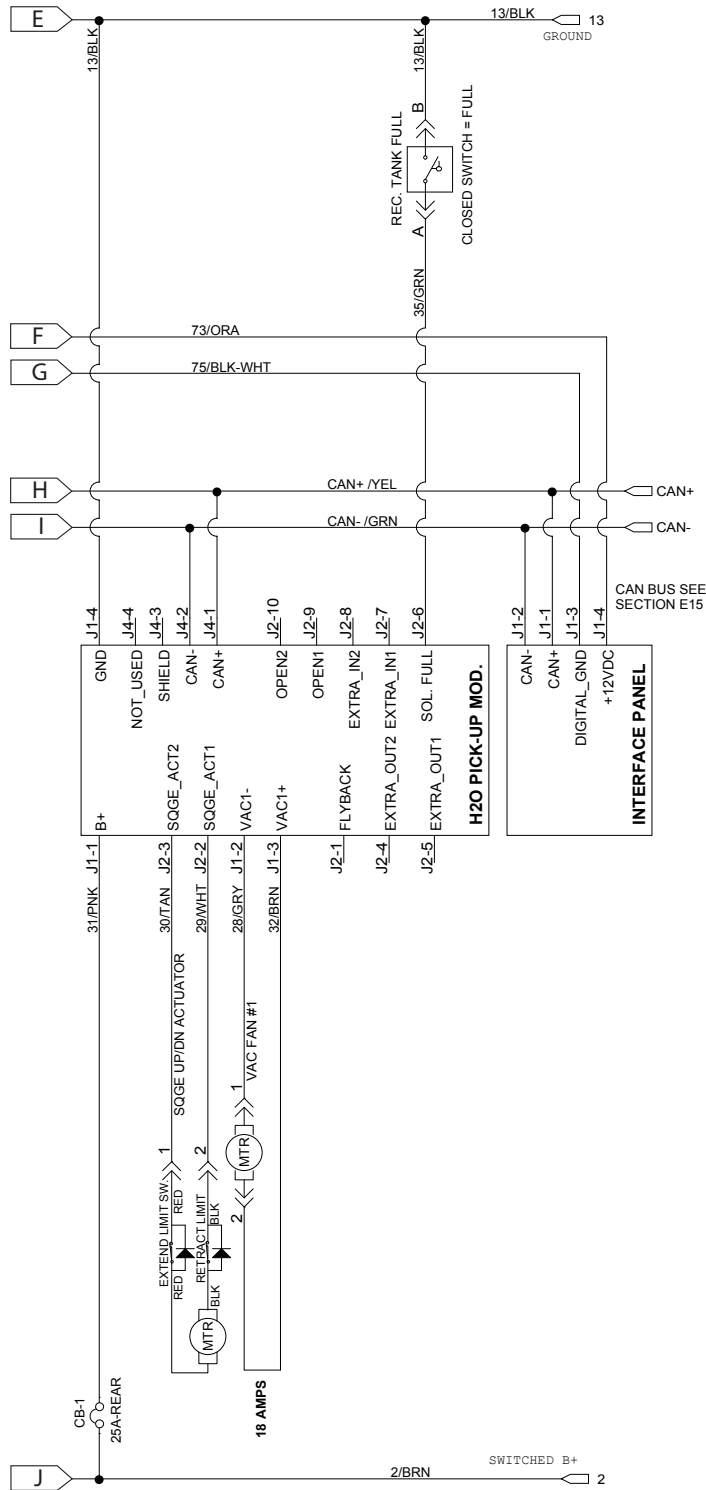

ELECTRICAL SCHEMATIC (4 of 6)

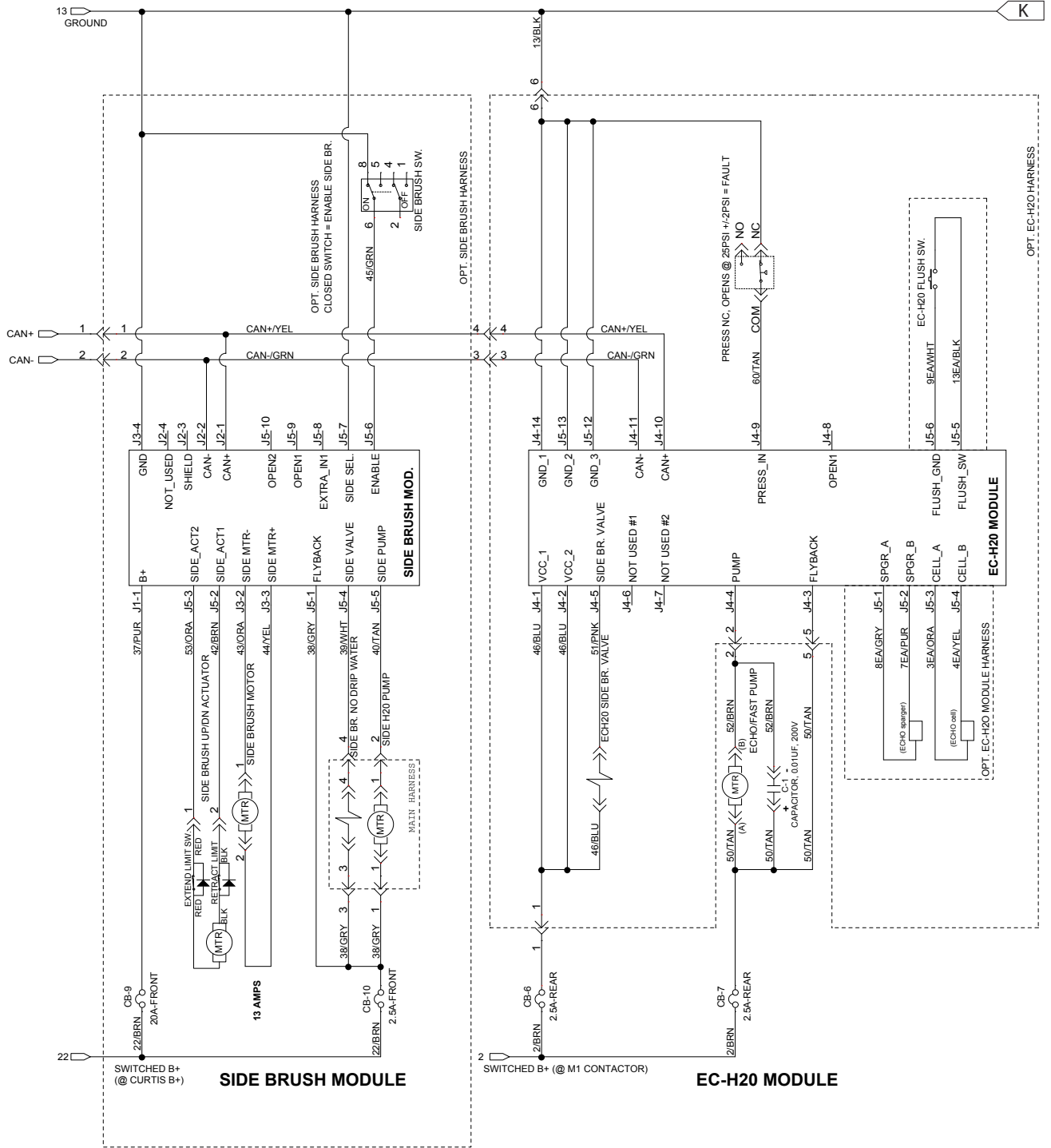

GENERAL INFORMATION

ELECTRICAL SCHEMATIC (5 of 6)

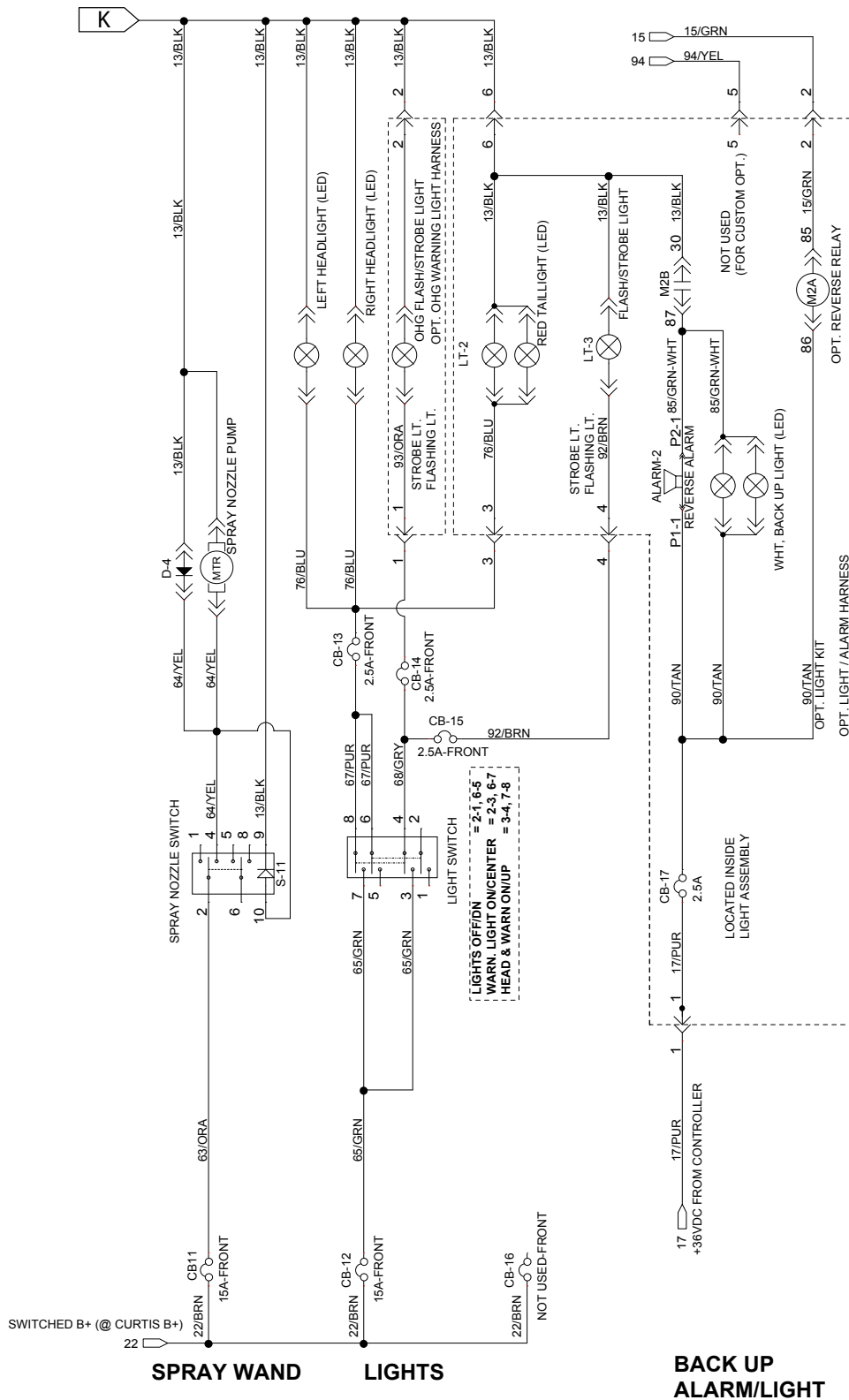

ELECTRICAL SCHEMATIC SYMBOLS

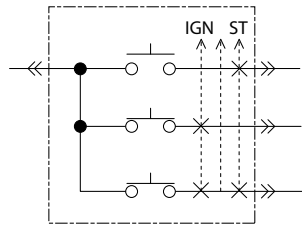

Key Switch

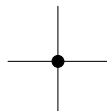

Connected

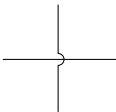

Not Connected

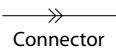

Connector



Energized

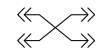

Adaptor Harness

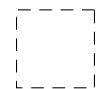

Notes

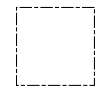

Assembly



AC Plug

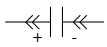

Capacitor



Battery

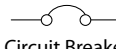

Circuit Breaker

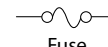

Fuse

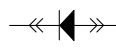

Diode



Single Continuation Tab



Double Continuation Tab



Relay Coil

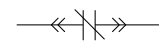

N.C. Relay Contacts

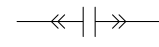

N.O. Relay Contacts



Horn or Alarm



Light

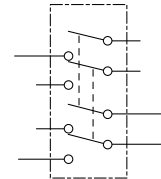

DPDT Switch

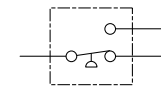

Pressure Switch



Motor

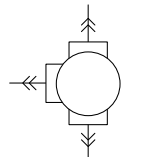

3 Phase AC Induction Motor

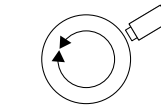

Motor Encoder



Sensor (Variable Resistor)

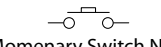

Momentary Switch N.O.

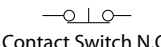

Contact Switch N.C.

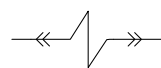

Solenoid Valve

GENERAL INFORMATION

T12 OPERATIONAL MATRIX

FUNCTION	ENABLED	DISABLED
Vacuum Fan, Scrubbing	<ul style="list-style-type: none"> • 1-STEP Scrub ON • Squeegee/Vacuum ON 	<ul style="list-style-type: none"> • 1-STEP Scrub OFF • Squeegee/Vacuum OFF • Recovery Tank Full • Very Low Battery Voltage • Load Current Fault
Rear Squeegee Down	<ul style="list-style-type: none"> • 1-STEP Scrub ON • Squeegee/Vacuum ON 	<ul style="list-style-type: none"> • 1-STEP Scrub OFF • Squeegee/Vacuum OFF • Reverse Propel • Recovery Tank Full • Very Low Battery Voltage • Load Current Fault
Rear Squeegee Up	<ul style="list-style-type: none"> • 1-STEP Scrub OFF • Squeegee/Vacuum OFF • Reverse Propel • Recovery Tank Full • Very Low Battery Voltage • Load Current Fault 	<ul style="list-style-type: none"> • 1-STEP Scrub ON • Squeegee/Vacuum ON
Main Scrub Brushes	<ul style="list-style-type: none"> • 1-STEP Scrub ON • Fwd/Rev Throttle Command 	<ul style="list-style-type: none"> • 1-STEP Scrub OFF • Neutral - Ready State • Recovery Tank Full • Solution Tank Empty • Very Low Battery Voltage • Load Current Fault
Scrub Head Down	<ul style="list-style-type: none"> • 1-STEP Scrub ON • Fwd/Rev Throttle Command 	<ul style="list-style-type: none"> • 1-STEP Scrub OFF • Neutral - Ready State • Recovery Tank Full • Solution Tank Empty • Very Low Battery Voltage • Load Current Fault
Scrub Head Up	<ul style="list-style-type: none"> • 1-STEP Scrub OFF • Neutral - Ready State • Recovery Tank Full • Solution Tank Empty • Very Low Battery Voltage • Load Current Fault 	<ul style="list-style-type: none"> • 1-STEP Scrub ON • Fwd/Rev Throttle Command
Side Brush Extend/Down	<ul style="list-style-type: none"> • 1-STEP Scrub ON • Side Brush Switch ON 	<ul style="list-style-type: none"> • 1-STEP Scrub OFF • Side Brush Switch OFF • Recovery Tank Full • Solution Tank Empty • Very Low Battery Voltage • Load Current Fault

MOM001

T12 OPERATIONAL MATRIX, continued

FUNCTION	ENABLED	DISABLED
Side Brush Retract/Up	<ul style="list-style-type: none"> • 1-STEP Scrub OFF • Side Brush Switch OFF • Recovery Tank Full • Solution Tank Empty • Very Low Battery Voltage • Load Current Fault 	<ul style="list-style-type: none"> • 1-STEP Scrub ON • Side Brush Switch ON
Side Brush	<ul style="list-style-type: none"> • 1-STEP Scrub ON • Side Brush Switch ON • Fwd/Rev Throttle Command 	<ul style="list-style-type: none"> • 1-STEP Scrub OFF • Side Brush Switch OFF • Neutral - Ready State • Recovery Tank Full • Solution Tank Empty • Very Low Battery Voltage • Load Current Fault
Solution Control (Conventional)	<ul style="list-style-type: none"> • 1-STEP Scrub ON • Solution Control ON • Fwd/Rev Throttle Command 	<ul style="list-style-type: none"> • 1-STEP Scrub OFF • Solution Control OFF • Neutral - Ready State • Recovery Tank Full • Solution Tank Empty • Very Low Battery Voltage • Load Current Fault
Solution Control (ecH2O)	<ul style="list-style-type: none"> • 1-STEP Scrub ON • Solution Control ON • ecH2O Button ON • Fwd/Rev Throttle Command 	<ul style="list-style-type: none"> • 1-STEP Scrub OFF • Solution Control OFF • ecH2O Button OFF • Neutral - Ready State • Recovery Tank Full • Solution Tank Empty • Very Low Battery Voltage • ecH2O System Fault • Load Current Fault
Propel	<ul style="list-style-type: none"> • Seat Switch Closed • Fwd/Rev Throttle Command • Fwd/Rev Switch Input 	<ul style="list-style-type: none"> • Seat Switch Open • Neutral - Ready State • Brake Command • Curtis 1232 Fault
Electromagnetic Parking Brake	<ul style="list-style-type: none"> • Key OFF • Emergency Stop Switch Open (Down) • Neutral (1-2 Second Delay) • Seat Switch Open • Curtis 1232 Fault 	<ul style="list-style-type: none"> • Key ON • Emergency Stop Switch Closed (Up) • Fwd/Rev Throttle Command • Seat Switch Closed
Back-Up Alarm/Lights	<ul style="list-style-type: none"> • Reverse Switch Input • Reverse Throttle Command 	<ul style="list-style-type: none"> • Forward Switch Input • Neutral - Ready State • Curtis 1232 Fault

MOM002

GENERAL INFORMATION

FASTENER TORQUE

SAE (STANDARD)

Thread Size	SAE Grade 1	SAE Grade 2 Carriage Bolts	Thread Cutting Thread Rolling	SAE Grade 5 Socket & Stainless Steel	SAE Grade 8	Headless Socket Set Screws	Square Head Set Screws	
4 (.112)	(5) - (6.5)					(4) - (6)		Inch Pounds
5 (.125)	(6) - (8)					(9) - (11)		
6 (.138)	(7) - (9)		(20) - (24)			(9) - (11)		
8 (.164)	(12) - (16)		(40) - (47)			(17) - (23)		
10 (.190)	(20) - (26)		(50) - (60)			(31) - (41)		
1/4 (.250)	4 - 5	5 - 6	7 - 10	7 - 10	10 - 13	6 - 8	17 - 19	Foot Pounds
5/16 (.312)	7 - 9	9 - 12	15 - 20	15 - 20	20 - 26	13 - 15	32 - 38	
3/8 (.375)	13 - 17	16 - 21		27 - 35	36 - 47	22 - 26	65 - 75	
7/16 (.438)	20 - 26	26 - 34		43 - 56	53 - 76	33 - 39	106 - 124	
1/2 (.500)	27 - 35	39 - 51		65 - 85	89 - 116	48 - 56	162 - 188	
5/8 (.625)		80 - 104		130 - 170	171 - 265		228 - 383	
3/4 (.750)		129 - 168		215 - 280	313 - 407		592 - 688	
1 (1.000)		258 - 335		500 - 650	757 - 984		1281 - 1489	

METRIC

Thread Size	4.8/5.6	8.8 Stainless Steel	10.9	12.9	Set Screws
M3	43 - 56 Ncm	99 - 128 Ncm	139 - 180 Ncm	166 - 215 Ncm	61 - 79 Ncm
M4	99 - 128 Ncm	223 - 290 Ncm	316 - 410 Ncm	381 - 495 Ncm	219 - 285 Ncm
M5	193 - 250 Ncm	443 - 575 Ncm	624 - 810 Ncm	747 - 970 Ncm	427 - 554 Ncm
M6	3.3 - 4.3 Nm	7.6 - 9.9 Nm	10.8 - 14 Nm	12.7 - 16.5 Nm	7.5 - 9.8 Nm
M8	8.1 - 10.5 Nm	18.5 - 24 Nm	26.2 - 34 Nm	31 - 40 Nm	18.3 - 23.7 Nm
M10	16 - 21 Nm	37 - 48 Nm	52 - 67 Nm	63 - 81 Nm	
M12	28 - 36 Nm	64 - 83 Nm	90 - 117 Nm	108 - 140 Nm	
M14	45 - 58 Nm	102 - 132 Nm	142 - 185 Nm	169 - 220 Nm	
M16	68 - 88 Nm	154 - 200 Nm	219 - 285 Nm	262 - 340 Nm	
M20	132 - 171 Nm	300 - 390 Nm	424 - 550 Nm	508 - 660 Nm	
M22	177 - 230 Nm	409 - 530 Nm	574 - 745 Nm	686 - 890 Nm	
M24	227 - 295 Nm	520 - 675 Nm	732 - 950 Nm	879 - 1140 Nm	

MACHINE DIMENSIONS

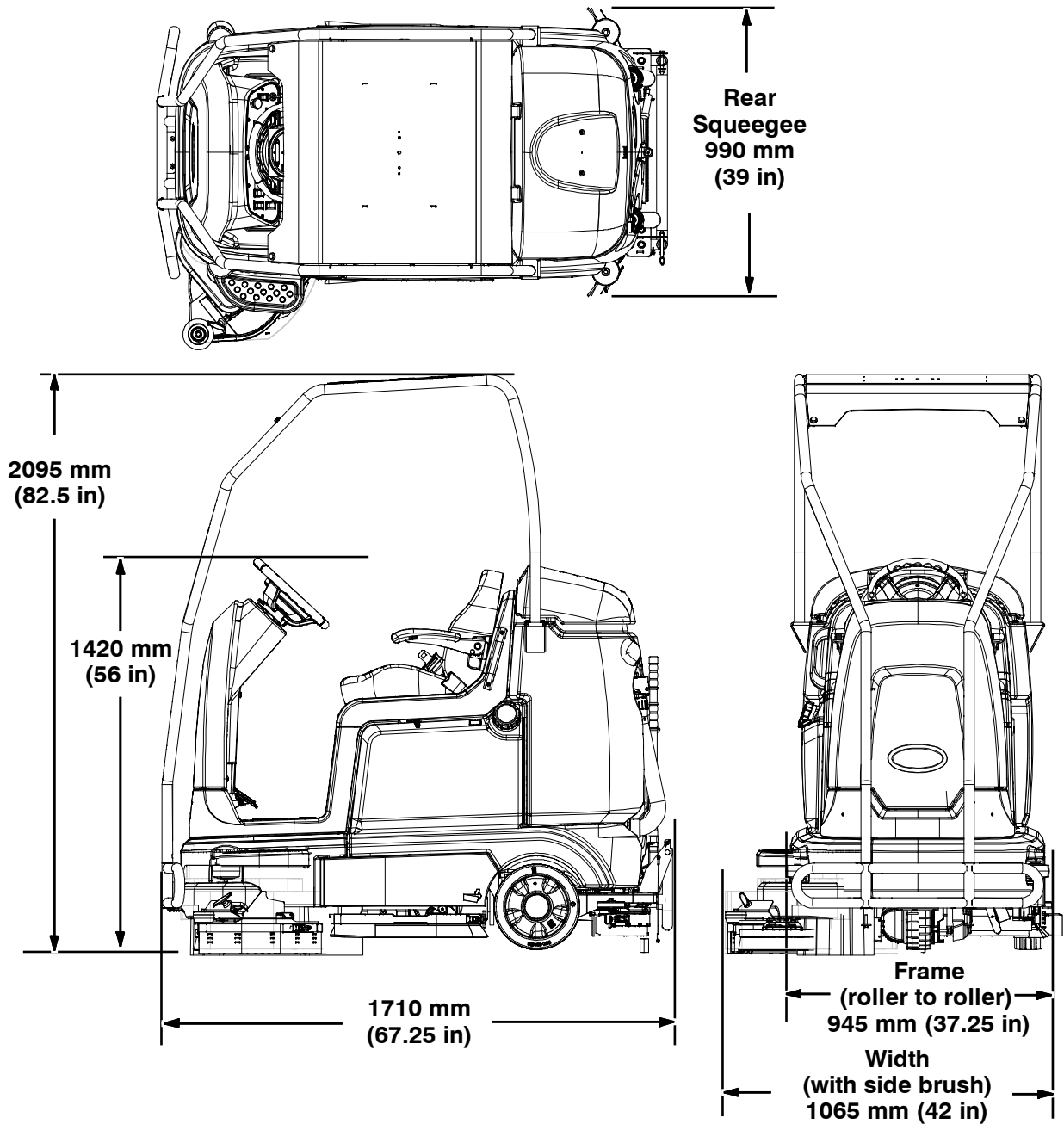

GENERAL INFORMATION

SPECIFICATIONS

GENERAL MACHINE DIMENSIONS/CAPACITIES

Item	Dimension/Capacity
Length	1710 mm (67.25 in)
Width (less squeegee)	945 mm (37.25 in)
Width (with squeegee)	990 mm (39 in)
Width (with side brush)	1065 mm (42 in)
Height	1420 mm (56 in)
Height with overhead guard	2095 mm (82.5 in)
Disk brush diameter for side brush (option)	330 mm (13 in)
Disk brush diameter	405 mm (16 in)
Cylindrical brush diameter	180 mm (7 in)
Cylindrical brush length	780 mm (30.7 in)
Scrubbing path width	810 mm (32 in)
Scrubbing path width (with side brush)	1040 mm (41 in)
Solution tank capacity	132 L (35 gallons)
Recovery tank capacity	166 L (44 gallons)
Demisting Chamber	34 L (9 gallons)
Weight (Empty)	468 Kg (1030 lbs)
Weight (with standard 240 AH batteries)	664 Kg (1460 lbs)
GVWR	1000 Kg (2200 lbs)

Values determined as per EN 60335-2-72	Measure - Cylindrical scrub head	Measure- Disk scrub head
Sound pressure level L_{pA}	63 dB(A)	62 dB(A)
Sound uncertainty K_{pA}	3.0 dB(A)	3.0 dB(A)
Sound power level L_{WA} + Uncertainty K_{WA}	-	-
Vibration - Hand-arm	-	-
Vibration - Whole body	-	-
Vibration uncertainty K	-	-

GENERAL MACHINE PERFORMANCE

Item	Measure
Aisle turnaround width	1854 mm (73 in)
Travel Speed (Forward)	8 Km (5 mph)
Travel Speed while scrubbing (Forward)	6.1 Km (3.8 mph)
Travel Speed (Reverse)	4 Km (2.5 mph)
Maximum rated climb and descent angle for transport - Empty	20%
Maximum rated climb angle for scrubbing	7%
Maximum rated climb and descent angle at gross weight (GVWR)	14.1%
Maximum ambient temperature for machine operation	43° C (110° F)
Minimum temperature for operating machine scrubbing functions	0° C (32° F)

SPECIFICATIONS

GENERAL MACHINE PERFORMANCE

Item	Measure
Runtime (economy mode)	240 AH, Up to 2.5 hours 360 AH, Up to 4.5 hours
Ground clearance (transport)	65 mm (2.5 in)
Vacuum fan speed	14500 RPM
Vacuum fan water lift	1650 mm (65 in)
Disk main brush speed	325 RPM
Disk main brush down pressure	Up to 114 kg (250 lb)
Cylindrical main brush speed	600 RPM
Cylindrical main brush down pressure	Up to 91 kg (200 lb)

POWER TYPE

Type	Quantity	Volts	Ah Rating	Weight
Batteries (Max. battery dimensions: 177.8 mm (7 in) W x 299.7 mm (11.8 in) L x 380 mm (15 in) H)	6	36	240 @ 20 hr rate	30 kg (67 lb)
	6	36	360 @ 20 hr rate	44 kg (97 lb)

Type	Use	Voltage	kW (hp)
Electric Motors	Scrub brush (disk)	36 VDC	0.75 (1.00)
	Scrub brush (cylindrical)	36 VDC	0.75 (1.00)
	Vacuum Fan	36 VDC	0.6 (0.8)
	Propelling	36 VAC	0.9 (1.2)

Type	VDC	Amperage	Hz	Phase	VAC
Chargers (Smart)	36	21	45-65	1	85-265
Chargers (On-board)	36	20	50-60	1	85-130
Chargers (On-board CE)	36	20	50-60	1	230/240

TIRES

Location	Type	Size
Front (1)	Solid	90 mm wide x 250 mm OD (3.5 in wide x 10 in OD)
Rear (2)	Solid	102 mm wide x 300 mm OD (4 in wide x 12 in OD)

ec-H2O SYSTEM (OPTION)

Item	Measure
Solution pump	36 Volt DC, 5A, 5.13 LPM (1.36 GPM) open flow,
Solution flow rate (machines without optional side brush)	1.9 LPM (0.5 GPM) maximum
Solution flow rate (machines with optional side brush)	1.9 LPM (0.5 GPM) - (To main scrub head)
	0.95 LPM (0.25 GPM) - (To side brush)

GENERAL INFORMATION

SPECIFICATIONS

ELECTRICAL COMPONENTS *(For Reference Only)*

Component	Measure
Contactator Coil, M1	126 Ω +/- 5%
Contactator Coil, M2	0.810 k Ω +/- 5%
Actuator, Scrub head lift	1 - 3 Amps continuous
Actuator, Side brush lift	1 - 3 Amps continuous, Internal limit switches
Actuator, Rear squeegee lift	2 - 4 Amps continuous, Internal limit switches
Motor, Vacuum Fan(s)	14 - 20 Amps continuous (16 Amps average)
Motor, Propelling (5.0 mph transport speed)	15 - 25 Amps continuous (20 amps average), 40-60 Amps Peak
Motors, Main cylindrical brush	
Down pressure #1	10 - 11 Amps/Motor (default 10 Amps)
Down pressure #2	11 - 16 Amps/Motor (default 14.5 Amps)
Down pressure #3	11 - 22 Amps/Motor (default 19 Amps)
Motors, Main disk brush	
Down pressure #1	11 Amps/Motor (Fixed)
Down pressure #2	11 - 16 Amps/Motor (default 16 Amps)
Down pressure #3	11 - 22 Amps/Motor (default 21 Amps)
Motor, Side Brush	5 - 8 Amps
Pump, ec-H ₂ O	4 - 6 Amps
Pump, Spray Nozzle	2 - 3 Amps
Pump, Side Brush	0.5 - 2 Amps
Valve, ec-H ₂ O Side Brush	129 Ω +/- 5%
Valve, Conventional Side Brush	108 Ω +/- 10%
Valve, Conventional Main Brush	108 Ω +/- 10%

SECTION 3

Contents	Page
MAINTENANCE	
MAINTENANCE CHART.....	3-2
LUBRICATION.....	3-4
BATTERIES.....	3-5
CHARGING THE BATTERIES (OFF-BOARD CHARGER)	3-6
CHARGING THE BATTERIES (ON-BOARD CHARGER)	3-7
ON-BOARD CHARGER ERROR CODES ...	3-8
ON-BOARD CHARGER SETTINGS.....	3-9
CHANGING THE ON-BOARD BATTERY CHARGER FUSE.....	3-10
FLOW-RITE™ BATTERY WATERING SYSTEM	3-11
CIRCUIT BREAKERS	3-13
ELECTRIC MOTORS	3-14
SCRUB BRUSHES.....	3-15
DISK BRUSHES AND PADS	3-15
REPLACING DISK BRUSHES (OR PAD DRIVERS).....	3-15
REPLACING DISK SCRUB PADS	3-16
CYLINDRICAL BRUSHES.....	3-17
REPLACING CYLINDRICAL BRUSHES.....	3-17
CHECKING CYLINDRICAL SCRUB BRUSH PATTERN.....	3-18
ADJUSTING CYLINDRICAL BRUSH TAPER	3-21
ADJUSTING CYLINDRICAL BRUSH PATTERN WIDTH.....	3-22
SIDE BRUSH (OPTION)	3-23
REPLACING THE SIDE BRUSH.....	3-23
SQUEEGEE BLADES.....	3-24
REPLACING OR ROTATING THE REAR SQUEEGEE BLADES	3-24
LEVELING THE REAR SQUEEGEE.....	3-27
ADJUSTING THE REAR SQUEEGEE BLADE DEFLECTION	3-28
REPLACING OR ROTATING THE SIDE SQUEEGEE BLADES	3-29
REPLACING OR ROTATING THE SIDE BRUSH SQUEEGEE BLADES (OPTION)	3-30
SKIRTS AND SEALS.....	3-31
BELTS	3-31
TIRES	3-31
PUSHING, TOWING, AND TRANSPORTING THE MACHINE	3-33
MACHINE JACKING	3-35

Contents	Page
ec-H2O MODULE FLUSH PROCEDURE.....	3-36
STORAGE INFORMATION.....	3-38
FREEZE PROTECTION	3-38
PREPARING THE MACHINE FOR OPERATION AFTER STORAGE	3-40
PRIMING THE EC-H2O SYSTEM.....	3-42

MAINTENANCE

MAINTENANCE

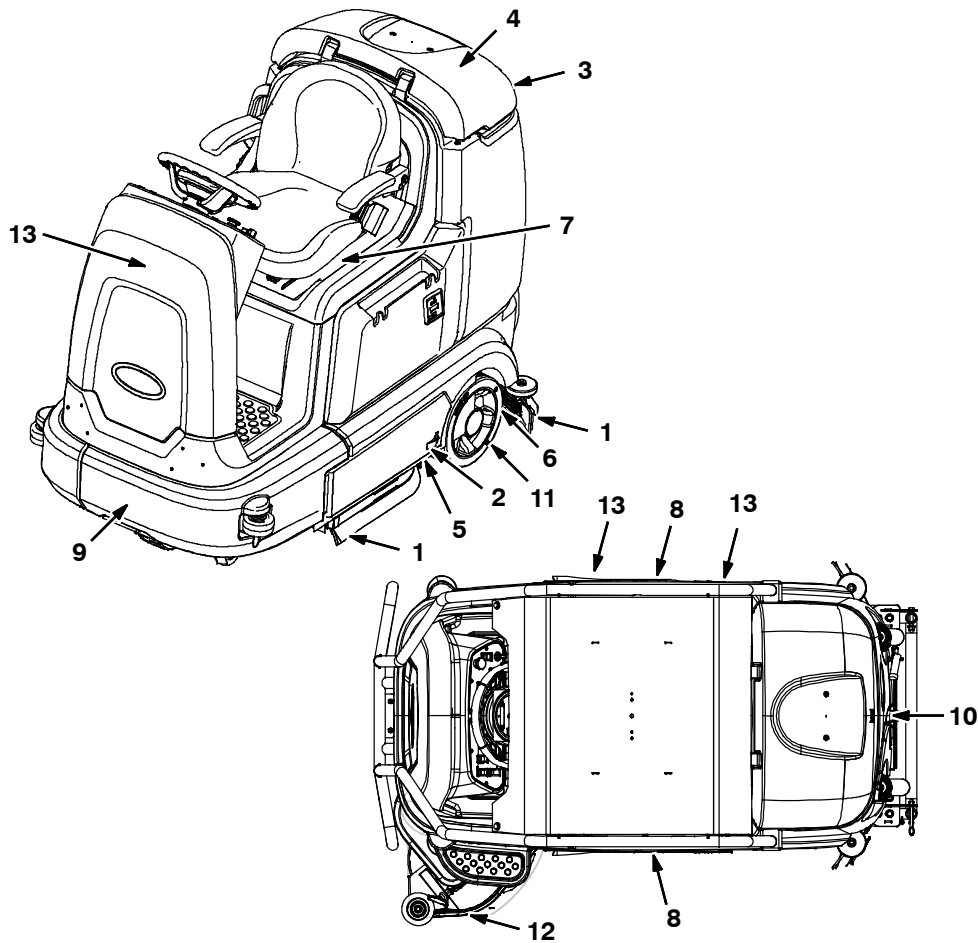

356389 356290

MAINTENANCE CHART

The table below indicates the *Person Responsible* for each procedure.

O = Operator.
T = Trained Personnel.

Interval	Person Resp.	Key	Description	Procedure	Lubricant/ Fluid	No. of Service Points
Daily	O	1	Side and rear squeegees	Check for damage and wear	-	4
	O	2	Main brushes	Check for damage, wear, and debris	-	2
	O	3	Recovery tank	Clean tank and check cover seal	-	1
	O	4	Vacuum fan inlet filter	Clean	-	1
	O	5	Cylindrical brushes only: Debris tray	Clean	-	1
	O	12	Side brush (Option)	Check for damage, wear, debris	-	1
	O	12	Side brush squeegee (Option)	Check for damage and wear	-	1

Interval	Person Resp.	Key	Description	Procedure	Lubricant/ Fluid	No. of Service Points
Weekly	T	7	Battery cells	Check electrolyte level	DW	12
50 Hours	T	6	Squeegee caster wheel pivot points	Lubricate	SPL	2
	T	1	Side and rear squeegees	Check deflection and leveling	-	4
	O	2	Main brushes (cylindrical)	Rotate brushes from front to rear	-	2
	T	13	Scrub head skirts (disk)	Check skirts for damage and wear	-	2
100 Hours	T	7	Battery watering system (option)	Check hoses and connections for damage and wear	-	Multiple
200 Hours	T	7	Battery terminals and cables	Check and clean	-	12
	T	8	Cylindrical brush drive belts	Check for damage and wear	-	2
	T	13	Steering chain (T12XP Only)	Lubricate, check tension, and check for damage and wear.	GL	1
	T	9	Steering gear chain	Lubricate, check tension, and check for damage and wear.	GL	1
500 Hours	T	10	Vacuum fan motor(s)	Check motor brushes	-	1 (2)
	O	11	Tires	Check for damage and wear	-	3
1000 Hours	T	8	Main brush motors	Check motor brushes (Check every 100 hours after initial 1000 hour check)	-	2 (4)
	T	12	Side brush motor	Check motor brushes (Check every 100 hours after initial 1000 hour check)	-	1

LUBRICANT/FLUID

DW Distilled water.

SPL . . . Special lubricant, Lubriplate EMB grease (Tennant part number 01433-1)

GL SAE 90 weight gear lubricant

NOTE: More frequent maintenance intervals may be required in extremely dusty conditions.

MAINTENANCE

LUBRICATION

FOR SAFETY: Before leaving or servicing machine, stop on level surface, turn off machine, and remove key.

STEERING CHAIN (T12XP ONLY)

The steering chain is located on the steering column directly under the control panel. Check for damage or wear and lubricate the steering chain after every 200 hours.

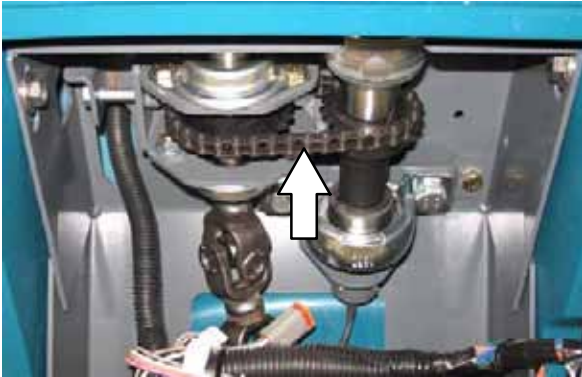

STEERING GEAR CHAIN

The steering gear chain is located directly above the front tire. Check for damage or wear and lubricate the steering gear chain after every 200 hours.



REAR SQUEEGEE CASTERS

Lubricate the rear squeegee caster pivot point on each squeegee caster after every 50 hours.



BATTERIES

The lifetime of the batteries is limited to the number of charges the batteries receive. To get the most life from the batteries, only recharge the batteries when the battery discharge indicator is down to the last bar. It's also important to maintain the proper electrolyte levels during the life of the battery.

CHECKING THE ELECTROLYTE LEVEL

NOTE: *Do Not* check the electrolyte level if the machine is equipped with the battery watering system. Proceed to **HYDROLINK BATTERY WATERING SYSTEM (OPTION)**.

Check the battery electrolyte level weekly for machines equipped with wet/lead acid batteries.

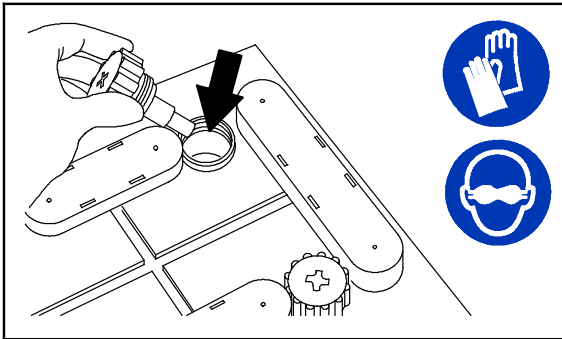

08247

FOR SAFETY: When servicing machine, avoid contact with battery acid.

The level should be slightly above the battery plates as shown before charging. Add distilled water if low. **DO NOT OVERFILL.** The electrolyte will expand and may overflow when charging.

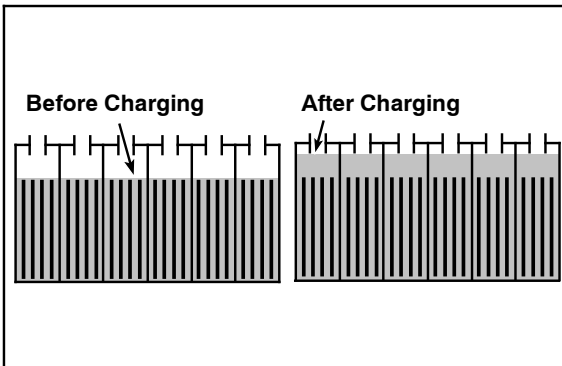

NOTE: Make sure the battery caps are in place while charging.

CHECKING CONNECTIONS / CLEANING

After every 200 hours of use check for loose battery connections and clean the surface of the batteries, including terminals and cable clamps, with a strong solution of baking soda and water. Replace any worn or damaged wires. Do not remove battery caps when cleaning batteries.



Objects made of metal can potentially short circuit the batteries. Keep all metallic objects off the batteries.

MEASURING THE SPECIFIC GRAVITY

Measuring the specific gravity, using a hydrometer, is a way to determine the charge level and condition of the batteries. If one or more of the battery cells test lower than the other battery cells (0.050 or more), the cell is damaged, shorted, or is about to fail.

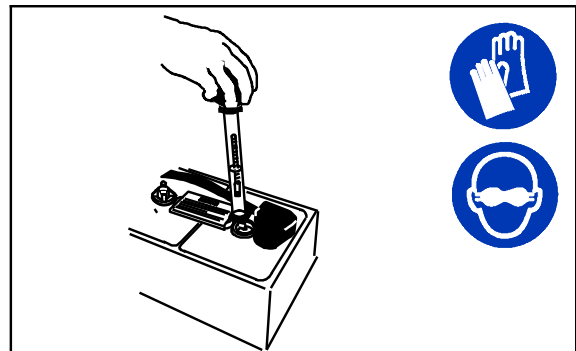

04380

FOR SAFETY: When maintaining or servicing machine, avoid contact with battery acid.

NOTE: Do not take readings immediately after adding distilled water. If the water and acid are not thoroughly mixed, the readings may not be accurate. Check the hydrometer readings against the following chart to determine the remaining battery charge level:

MAINTENANCE

SPECIFIC GRAVITY at 27° C (80° F)	BATTERY CHARGE
1.277	100% Charged
1.238	75% Charged
1.195	50% Charged
1.148	25% Charged
1.100	Discharged

NOTE: If the readings are taken when the battery electrolyte is any temperature other than shown, the reading must be temperature corrected. Add or subtract to the specific gravity reading 0.004, 4 points, for each 6° C (10° F) above or below 25° C (77° F).

CHARGING THE BATTERIES (OFF-BOARD CHARGER)

IMPORTANT: Before charging, make sure that the charger setting is properly set for the battery type.

1. Drive the machine to a flat, dry surface in a well-ventilated area.
2. Stop the machine and turn off the machine power.

FOR SAFETY: Before leaving or servicing machine, stop on level surface, turn off machine, and remove key.

3. Lift the operator seat open and engage the seat support.

NOTE: Make sure the batteries have the proper electrolyte level before charging. See CHECKING THE ELECTROLYTE LEVEL.

4. Plug the charger AC power supply cord into a properly grounded outlet.

5. Plug the charger connector into the remote battery charge connector.

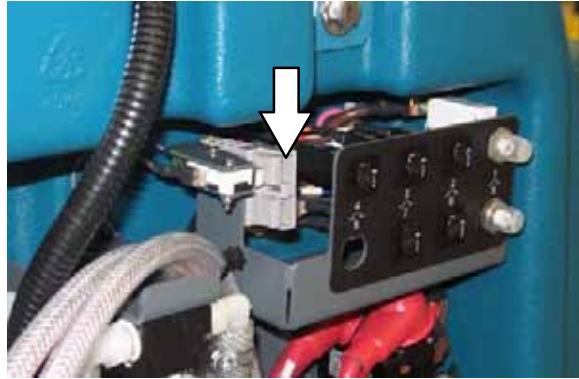

WARNING: Batteries emit hydrogen gas. Explosion or fire can result. Keep sparks and open flame away. Keep covers open when charging.

NOTE: If the charger "FAULT CODE" lights flash when the batteries are plugged into the charger, refer to the charger manufacturer manual for fault code definitions.

6. The Tennant charger will start automatically. When the batteries are fully charged, the Tennant charger will automatically turn off.
7. After the charger has turned off, unplug the charger connector from the remote battery charge connector.

ATTENTION: Do not disconnect the charger DC cord from the machine receptacle when the charger is operating. Arcing may result. If the charger must be interrupted during charging, disconnect the AC power supply cord first.

8. Close the operator seat.

CHARGING THE BATTERIES (ON-BOARD CHARGER)

IMPORTANT: Before charging, make sure that the charger setting is properly set for the battery type. See *ON-BOARD CHARGER SETTINGS*.

1. Drive the machine to a flat, dry surface in a well-ventilated area.
2. Stop the machine and turn off the machine power.

FOR SAFETY: Before leaving or servicing machine, stop on level surface, turn off machine, and remove key.

3. Lift the operator seat open and engage the seat support.

NOTE: Make sure the batteries have the proper electrolyte level before charging. See *CHECKING THE ELECTROLYTE LEVEL*.

4. Plug the on-board battery charger cord into a properly grounded wall outlet.



WARNING: Batteries emit hydrogen gas. Explosion or fire can result. Keep sparks and open flame away. Keep covers open when charging.

NOTE: The machine will not operate when charging.

5. The on-board charger will start charging the batteries. Once the charging cycle begins, the indicator lights will progress from red, yellow to green. When the green indicator light stays on, the charging cycle is done.



If the charger detects a problem, the charger will display an error code (See *ON-BOARD BATTERY CHARGER ERROR CODES*).

6. Unplug the on-board battery charger cord from the wall outlet and neatly stow the cord inside the battery compartment.



7. Close the operator seat.

MAINTENANCE

ON-BOARD BATTERY CHARGER ERROR CODES

Display Code	Fault	Solution
bat	Loose or damaged battery cable.	Check battery cable connection.
	Battery exceeded maximum voltage level.	No action necessary.
E01	Exceeded maximum battery voltage allowed. Interrupts charging cycle.	No action necessary.
E02	Safety thermostat exceeded maximum internal temperature. Interrupts charging cycle.	Ensure the charger vents are not obstructed. Clear obstructions.
E03	Exceeded maximum time for charging phase, leaving the batteries undercharged due to a sulfated or faulty battery. Interrupts charging cycle.	Repeat the charging cycle. If the error code E03 reappears check battery or replace it.
SCt	Safety timer exceeded maximum charging time. Interrupts charging cycle.	Replace battery.
Srt	Possible internal short circuit.	Contact a Tennant service representative.

ON-BOARD CHARGER SETTINGS

If the machine is equipped with the on-board charger, the charger settings are properly set at the factory. If different batteries are put in the machine, the settings must be changed to match the new battery type before charging. Failure to properly set the charger will result in battery damage.

Refer to the battery label for the battery type. Contact the battery manufacturer if battery is not labeled.

To verify the setting of the charger, connect the charger cord into an electrical outlet. The charger will display a sequence of the following codes (three-digits + the code) when the cord is connected:

- A = Charging current
- U = Battery Voltage
- h = Charging time
- C = Charging ampere-hours [Ah]
- E = Energy used [Kwh]
- "GEL" or "Acd" = Battery type for which the charger is currently set. Before charging make sure battery type matches the display: GEL=Sealed, Acd=WET (lead acid).

Press the arrow button to review the codes. Refer to the battery type code to determine the charger battery type setting.



To change the setting, unplug the charger and peel up the corner of the display label to access the switches. The charger cord must be unplugged when resetting.



Adjust the switches to the correct setting for the batteries.

Lead Acid 240Ah:

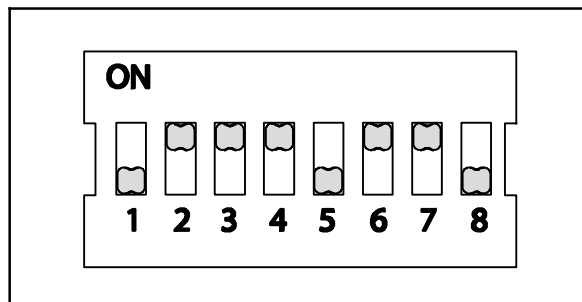

Lead Acid 360Ah:

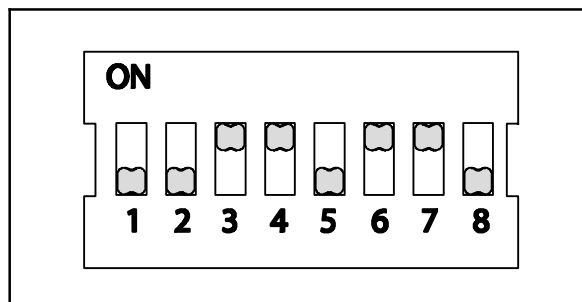

Gel:

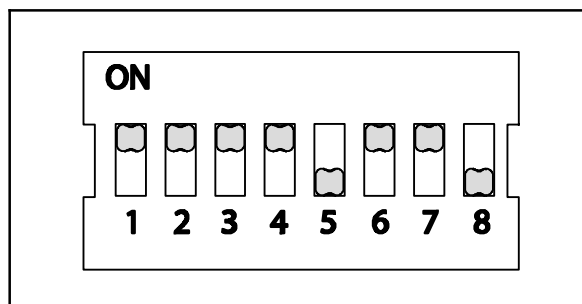

MAINTENANCE

CHANGING THE ON-BOARD BATTERY CHARGER FUSE

FOR SAFETY: Before leaving or servicing machine, stop on level surface, turn off machine, and remove key.

A 15 Amp fuse protects the on-board charger. Follow the instructions below to replace a blown fuse. Never substitute a higher Amp rated fuse than specified.

1. Lift the operator seat open and engage the seat support.
2. Unplug the charger AC power supply cord from the wall outlet.

WARNING: Electrical Hazard. Unplug charger before servicing machine.

3. Disconnect the battery cables from the batteries.

FOR SAFETY: When servicing machine, disconnect battery connection before working on machine.

4. Remove the hardware holding the side panel to the machine and remove the side panel from the machine.



5. Remove the hardware holding the on-board battery charger onto the machine



6. Carefully pull the on-board charger out to access the fuse.
7. Remove the fuse cap and replace the fuse.



8. Reinstall the on-board battery charger and side panel onto the machine.

FLOW-RITE™ BATTERY WATERING SYSTEM (OPTION)

The optional Flow-Rite battery watering system provides a safe and easy way to maintain the proper electrolyte levels in the batteries.

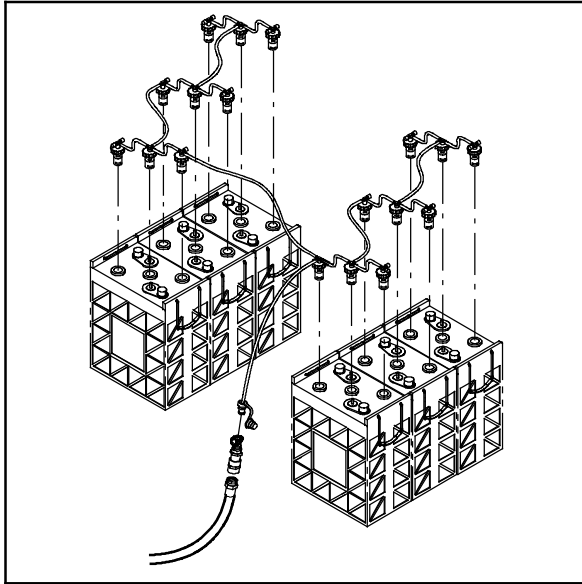

Check for the battery watering system hoses and connections for damage or wear after every 100 hours.

FOR SAFETY: Before leaving or servicing machine, stop on level surface, turn off machine, and remove key.

1. Lift the operator seat open and engage the seat support.
2. Fully charge batteries prior to using the battery watering system. Do not add water to batteries before charging, the electrolyte level will expand and may overflow when charging. See *CHARGING THE BATTERIES (OFF-BOARD CHARGER)* or *CHARGING THE BATTERIES (ON-BOARD CHARGER)*.

3. Connect the water supply hose to the fill regulator.

NOTE: Water quality is important to maintain the life of the battery. Always use water that meets battery manufacturer requirements.



NOTE: The water supply to the battery water system must always be 7.57 LPM (2 GPM) or more. Use the purger to confirm the water supply pressure. Refer to Flow-Rite Operator Manual for additional information.



4. Remove the dust cover from the battery fill tube and connect the fill regulator.



MAINTENANCE

5. Turn on the water supply. The red balls inside the flow indicator will spin. The red balls stop spinning when the batteries are full.

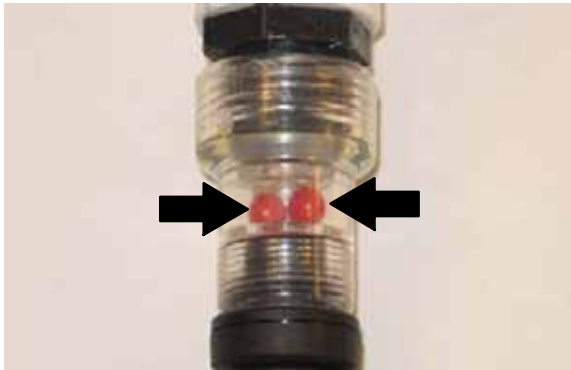

6. Disconnect the battery fill tube from the fill regulator.
7. Turn off the water supply.
8. After adding water, replace the dust cap on the battery fill hose and return the fill regulator to the storage location for future use.

CIRCUIT BREAKERS

Circuit breakers are resettable electrical circuit protection devices designed to stop the flow of current in the event of a circuit overload. Once a circuit breaker is tripped, reset it manually by pressing the reset button after the breaker has cooled down.

Circuit breakers 1 through 8 are located behind the operator seat.

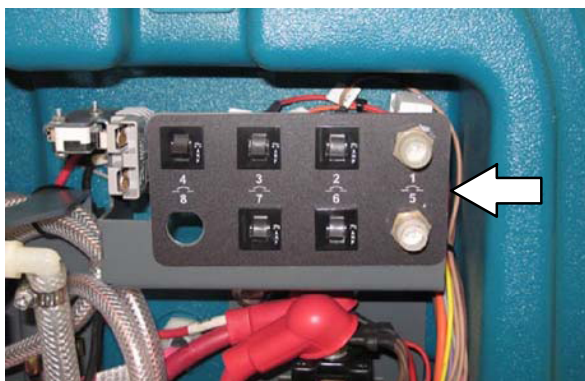

Circuit breakers 9 through 16 are located behind the steering shroud access panel.

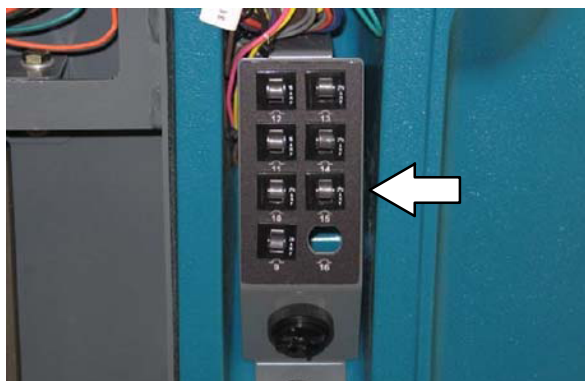

Circuit breaker 17 is located inside the optional light assembly mounted on top of the recovery tank.

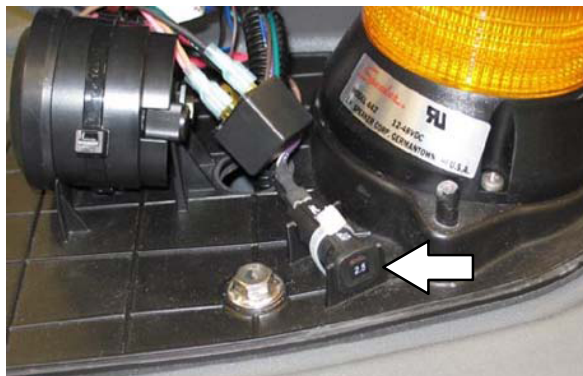

If the overload that caused the circuit breaker to trip is still present, the circuit breaker will continue to stop current flow until the problem is corrected.

The chart below shows the circuit breakers and the electrical components they protect.

Circuit Breaker	Rating	Circuit Protected
CB1	80 A	Propel system
CB2	2 A	Telemetry system
CB3	2.5 A	Key switch - Start
CB4	2.5 A	Scrub system
CB5	60 A	Scrub module
CB6	2.5 A	<i>ec-H2O</i> module (Option)
CB7	2.5 A	<i>ec-H2O</i> pump (Option)
CB8	2.5 A	Not used
CB9	20 A	Side brush module (Option)
CB10	2.5 A	Side brush system (Option)
CB11	15 A	Spray nozzle pump (Option)
CB12	15 A	Lights (Option)
CB13	2.5 A	Headlight / Tail lights (Option)
CB14	2.5 A	Overhead guard warning light (Option)
CB15	2.5 A	Warning lights (Option)
CB16	N/A	Not used
CB17	2.5A	Reverse alarm light (Option)

MAINTENANCE

ELECTRIC MOTORS

Inspect the carbon brushes on the vacuum fan motor after every 500 hours of operation. Inspect the carbon brushes on the main brush motors and side brush motor after the first 1000 hours of operation and every 100 hours after the initial check. Refer to the table below for carbon brush replacement intervals.

Carbon Brush Replacement	Hours
Main Brush Motors	1000*
Side Brush Motor (Option)	1000*
Vacuum Motor	500

**Replace carbon brushes every 100 hours after the initial 1000 hour change.*

SCRUB BRUSHES

The machine can be equipped with either *disk* or *cylindrical* scrub brushes. Check scrub brushes daily for wire or string tangled around the brush or brush drive hub. Also check brushes or pads for damage and wear.

DISK BRUSHES AND PADS

Replace the brushes or pads when they no longer clean effectively.

Cleaning pads must be placed on pad drivers before they are ready to use. The cleaning pad is held in place with a center disk. Both sides of the pad can be used for scrubbing. Turn the pad over to use the other side.

Cleaning pads need to be cleaned immediately after use with soap and water. Do not wash the pads with a pressure washer. Hang pads, or lay pads flat to dry.

NOTE: Always replace brushes and pads in sets. Otherwise one brush or pad will be more aggressive than the other.

REPLACING DISK BRUSHES OR PAD DRIVERS

1. Raise the scrub head.
2. Turn off the machine.

FOR SAFETY: Before leaving or servicing machine, stop on level surface, turn off machine, and remove key.

3. Open the main brush access door and side squeegee support door.



4. Turn the brush until the spring handles are visible.



5. Squeeze the spring handles and let the brush drop to the floor.
6. Push the new brush under the scrub head, align the brush drive socket with the brush drive hub, and lift the brush up onto the brush drive hub.
7. Ensure the brush is securely mounted on the brush drive hub.
8. Close and secure the squeegee support door and close the main brush access door.
9. Repeat procedure for the other brush.

MAINTENANCE

REPLACING DISK SCRUB PADS

1. Remove the pad driver from the machine.
2. Squeeze the spring clip together and remove the center disk from the pad driver.



3. Remove the scrub pad from the pad driver.



4. Flip or replace the scrub pad. Center the scrub pad on the pad driver and reinstall the center disk to secure the pad in place on the pad driver.
5. Reinstall the pad driver onto the machine.

CYLINDRICAL BRUSHES

Rotate the brushes from front-to-rear after every 50 hours of operation.

Replace the brushes when they no longer clean effectively.

NOTE: Replace worn brushes in pairs. Scrubbing with brushes of unequal bristle length will result in diminished scrubbing performance.

REPLACING CYLINDRICAL SCRUB BRUSHES

FOR SAFETY: Before leaving or servicing machine, stop on level surface, turn off machine, and remove key.

1. Open the main brush access door and side squeegee support door.



2. Remove the idler plate from the scrub head.



3. Remove the brush from the scrub head



4. Position the brush with the *double row end towards the scrub head opening*. Guide the new brush onto the drive hub.
5. If rotating the brushes, always rotate the front with the back so that they wear evenly. They may be rotated end for end as well.

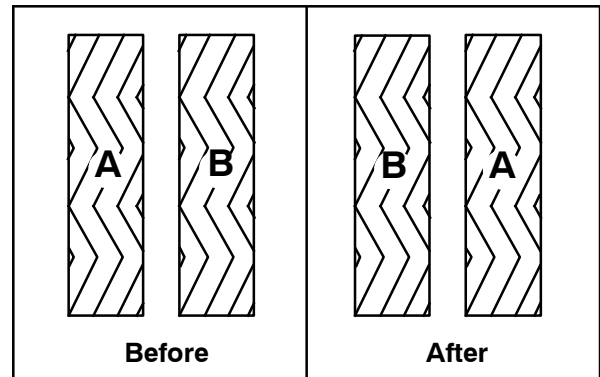

6. Reinstall the idler plate onto the scrub head.
7. Close and secure the squeegee support door and close the main brush access door.
8. Repeat for the brush on the other side of the scrub head.

MAINTENANCE

CHECKING CYLINDRICAL SCRUB BRUSH PATTERN

FOR SAFETY: Before leaving or servicing machine, stop on level surface and turn off machine.

1. Apply chalk, or a similar marking material, to a smooth and level section of floor.

NOTE: If chalk or other material is not available, allow the brush to spin on the floor for two minutes. A polish mark will remain on the floor.

2. Park the machine several feet behind the chalked area and shut off the machine.
3. Press and hold the *configuration mode button* while turning the key to the on position. Continue holding the *configuration mode button* until CONFIG MODE appears on the LCD display. Release the *configuration mode button*.



4. Press the *Brush pressure button* to enter the machine configuration modes.

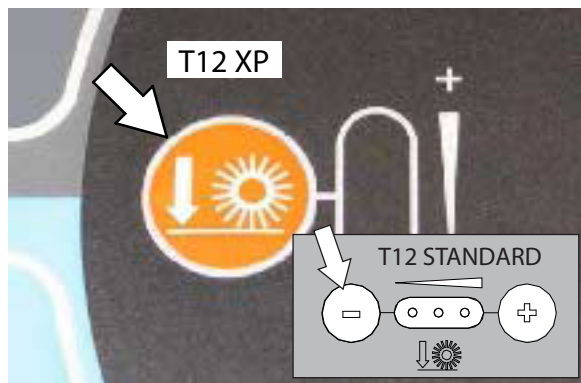

C1: Disk/Cyl Cyl should appear in the LCD display.



5. Press the *Contrast control button* once to scroll to **C16: Dwn Pres Tst Disabled** (Down Pressure Test Disabled).



6. Press the *Brush pressure button* to enter the down pressure test selection mode.

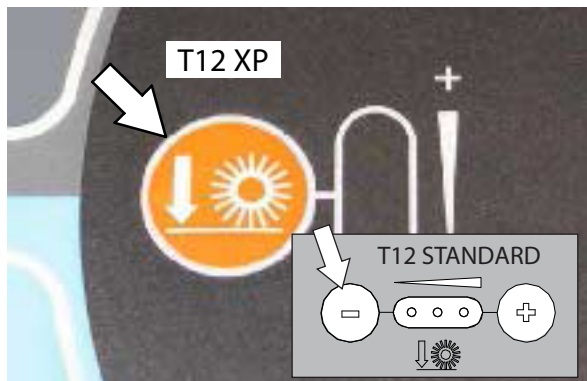

8. Press the *Brush pressure button* to enable the brush pressure test.

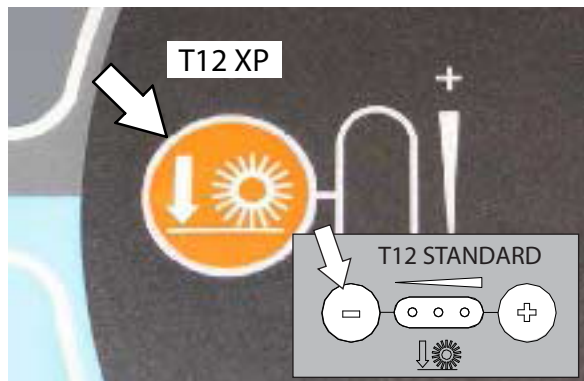

C16: Dwn Pres Tst <Disabled (Down Pressure Test Disabled) should appear on the LCD display. The < symbol must appear in front of **Disabled** .



C16: Dwn Pres Tst Enabled should appear on the LCD display. The < symbol should no longer appear in front of **Enabled**



7. Press the *Contrast control button* once to select **C16:Dwn Pres Tst <Enabled** (Down Pressure Test Enabled). The < symbol must appear in front of **Enabled**.



9. Turn the key to the off position to save the Down Pressure Test Enabled mode and then turn the key back to the on position to continue with the procedure.

Note: Do Not turn off the machine second time after the Down Pressure Test Enabled mode has been saved. The entire procedure to get the machine into the Down Pressure Test Mode will need to be repeated if the machine is turned off a second time.

MAINTENANCE

10. Press the *1-STEP* button and then immediately press one of the *Solution on/off* buttons to shut off the solution supply and prevent the brushes from getting wet.

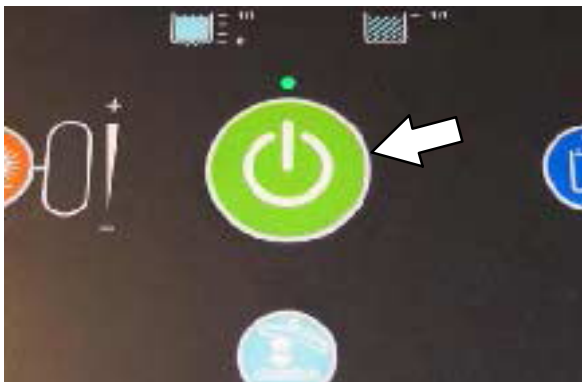

11. Observe the solution flow indicator lights. None of the indicator lights should be illuminated.



12. Press the *1-STEP* button to raise the scrub head.

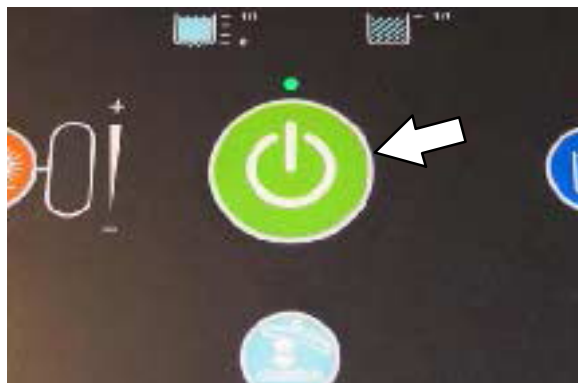

13. Position the machine over the chalked area.

14. Press the *1-STEP* button to lower the scrub head and allow the brushes to operate for 15 to 20 seconds. Keep the scrub head in one spot in the chalked area.

NOTE: If necessary, press the Brush pressure button to set the brush pressure to the medium setting.



15. Press the *1-STEP* button to raise the scrub head and drive the machine away from the chalked area.

16. Observe the brush patterns. If the brush pattern is the same width across the entire length of each brush and both brushes are the same width, no adjustment is necessary.

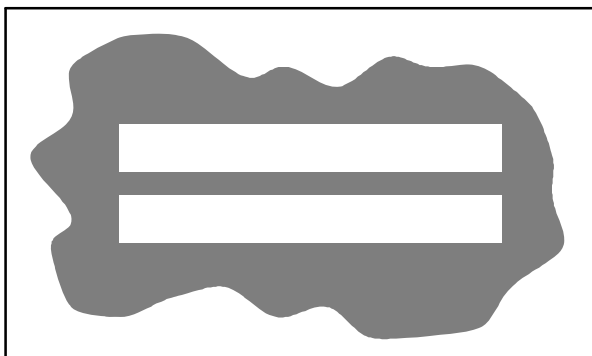

10355

17. If the brush patterns are tapered, see *ADJUSTING THE CYLINDRICAL BRUSH TAPER* section of this manual.

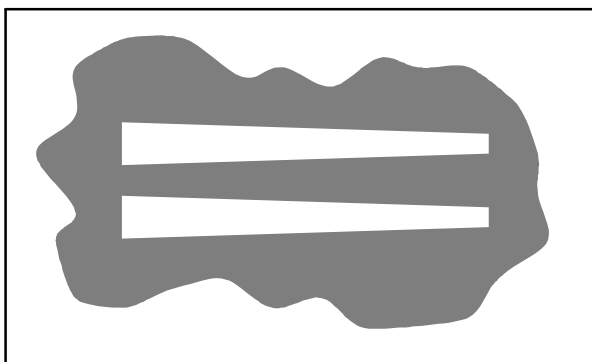

10652

18. The brush patterns should be 25 to 38 mm (1 to 1.5 in) wide with the brushes in the lowered position and both patterns should be the same width. If the width of the brushes is not the same, see *ADJUSTING THE CYLINDRICAL BRUSH WIDTH* section of this manual.

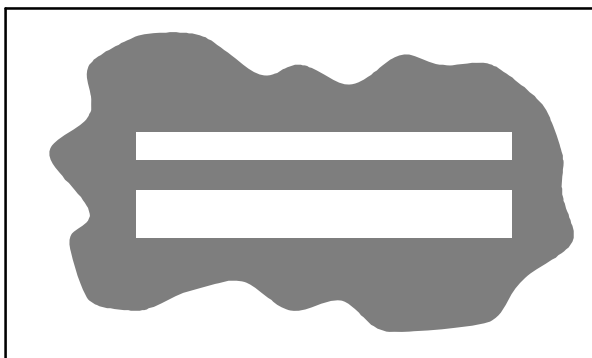

ADJUSTING CYLINDRICAL BRUSH TAPER

FOR SAFETY: Before leaving or servicing machine, stop on level surface and turn off machine.

1. Open the side squeegee support door.



2. Remove the idler door and loosen the idler shaft. The shaft is a concentric cam.



3. Raise or lower the end of the brush using the shaft adjustment as necessary to straighten the brush pattern.
4. Retighten the mounting screw on the idler door.
5. Close the side squeegee support door.
6. Recheck the pattern. Readjust if necessary.
7. Repeat procedure for the other brush located on other side of the scrub head.

MAINTENANCE

ADJUSTING CYLINDRICAL BRUSH PATTERN WIDTH

FOR SAFETY: Before leaving or servicing machine, stop on level surface and turn off machine.

1. Start the machine, completely lower the scrub head, and turn off the machine.
2. Open the side squeegee support door.
3. Loosen the bolt securing the adjustment bracket located on the front of the scrub head frame.



4. Rotate the adjustment bracket to adjust the cylindrical brush pattern width.

NOTE: The adjustment bracket rotates a concentric cam, which changes the height of the scrub head.

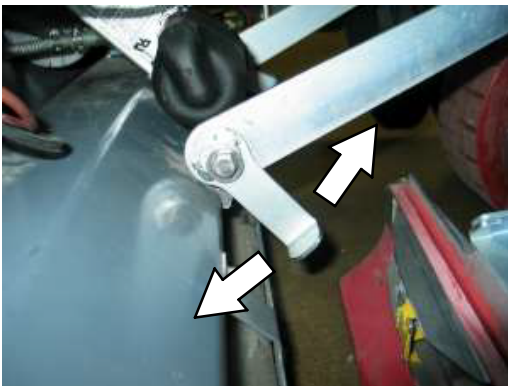

5. Retighten the lock bolt located against the bracket.
6. Recheck the pattern. Readjust if necessary.

SIDE BRUSH (OPTION)

FOR SAFETY: Before leaving or servicing machine, stop on level surface, turn off machine, and remove key.

Check the side brush daily for wear or damage. Remove any tangled string or wire from the side brush or side brush drive hub.

REPLACING THE SIDE BRUSH

Replace the brush when it no longer cleans effectively.

1. Loosen the side brush squeegee assembly handle and remove the squeegee assembly from the machine.



2. Squeeze the spring handles and let the side brush drop to the floor.



3. Remove the side brush from under the side brush assembly.



4. Place the new side brush underneath the side brush assembly and lift the side brush up onto the side brush hub until the brush locks onto the hub.
5. Reinstall the side brush squeegee assembly onto the side brush assembly.

MAINTENANCE

SQUEEGEE BLADES

Check the squeegee blades for damage and wear daily. When the blades become worn, rotate the blades end-for-end or top-to-bottom to a new wiping edge. Replace blades when all edges are worn.

Check the deflection of the squeegee blades daily or when scrubbing a different type of surface. Check the leveling of the rear squeegee every 50 hours of operation.

REPLACING (OR ROTATING) THE REAR SQUEEGEE BLADES

1. Lower the scrub head.

FOR SAFETY: Before leaving or servicing machine, stop on level surface, turn off machine, and remove key.

2. Disconnect the vacuum hose from the rear squeegee assembly.



3. Loosen both squeegee mounting handles.

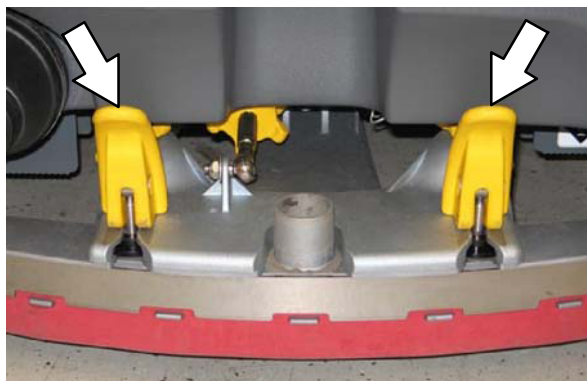

4. Pull the rear squeegee assembly from the machine.



5. Loosen the retainer latch and remove the retainer from the squeegee assembly.



6. Remove the squeegee from the squeegee assembly.



7. Slide both retainers out away from the squeegee assembly.



8. Remove the inner frame from the outer frame.



9. Remove the squeegee from the outer frame.



10. Install the rotated or new squeegee blade into the outer frame. Be sure the squeegee is completely slid down onto each tab on the outer frame.

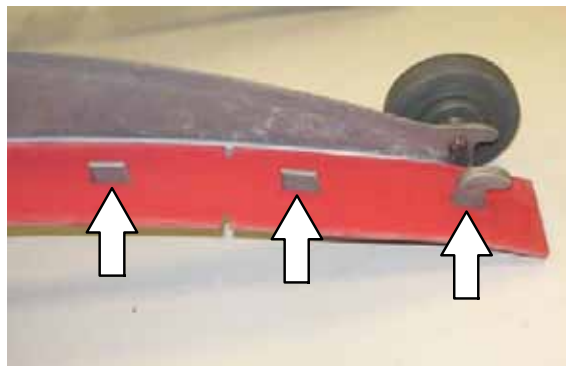

MAINTENANCE

11. Install the inner frame over the squeegee and onto the outer frame. Be sure the inner frame is tight against the top of the outer frame.

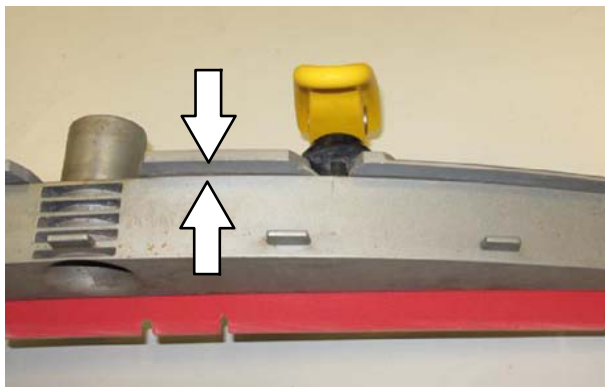

12. Slide both retainers into the squeegee assembly.



13. Place the rotated or new squeegee blade onto the inner frame. Be sure the squeegee is securely attached on each tab on the inner frame.



14. Insert the hinge end of the retainer into the hooks in the inner frame.

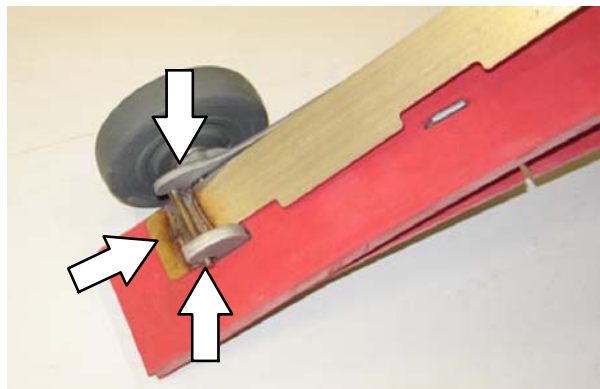

15. Install the retainer along the rest of the squeegee assembly and fasten the latch onto the other end of the squeegee assembly.

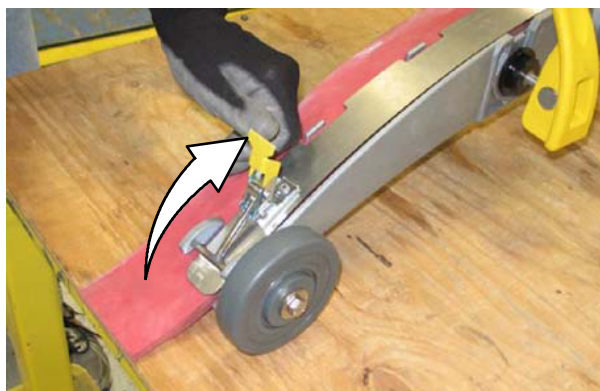

LEVELING THE REAR SQUEEGEE

Leveling the squeegee ensures the entire length of the squeegee blade is in even contact with the surface being scrubbed. Perform this adjustment on an even and level floor.

1. Lower the squeegee and drive the machine several meters (feet) forward and slowly bring the machine to a stop.

FOR SAFETY: Before leaving or servicing machine, stop on level surface, turn off machine, and remove key.

2. Check the squeegee deflection over the full length of the squeegee blade.
3. If the deflection is not the same over the full length of the blade, use the tilt adjust knob to make adjustments.

DO NOT disconnect the vacuum hose from the squeegee frame when leveling squeegee.

4. To adjust the squeegee leveling, loosen the tilt lock knob.



5. Turn the squeegee tilt adjust knob counter-clockwise to decrease the deflection at the ends of the squeegee blade.

Turn the squeegee tilt adjust knob clockwise to increase the deflection at the ends of the squeegee blade.



6. Tighten the tilt lock knob.
7. Drive the machine forward with the squeegee down to recheck the squeegee blade deflection if adjustments were made.
8. Readjust the squeegee blade deflection if necessary.

MAINTENANCE

ADJUSTING THE REAR SQUEEGEE BLADE DEFLECTION

Deflection is the amount of curl the overall squeegee blade has when the machine moves forward. The best deflection is when the squeegee wipes the floor dry with a minimal amount of deflection.

NOTE: Make sure the squeegee is level before adjusting the deflection. See LEVELING THE REAR SQUEEGEE.

1. Lower the squeegee and drive the machine several meters (feet) forward and slowly bring the machine to a stop.

FOR SAFETY: Before leaving or servicing machine, stop on level surface, turn off machine, and remove key.

2. Look at the amount of deflection or “curl” of the squeegee blade. The correct amount of deflection is 12 mm (0.50 in) for scrubbing smooth floors and 15 mm (0.62 in) for rough floors.

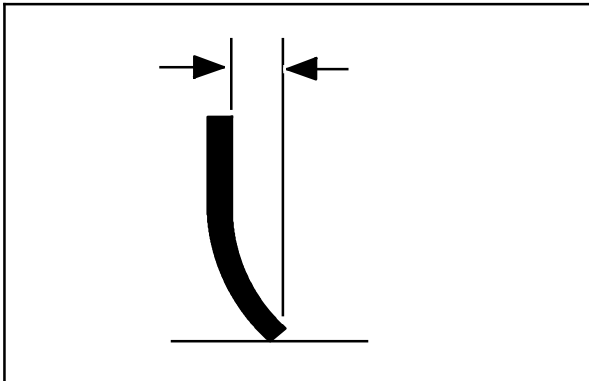

3. To adjust the overall squeegee blade deflection, loosen the lock knob.

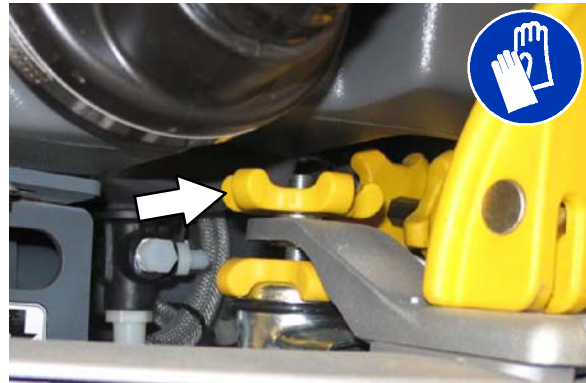

4. Turn the adjustment knobs counterclockwise to increase deflection or clockwise to decrease deflection.

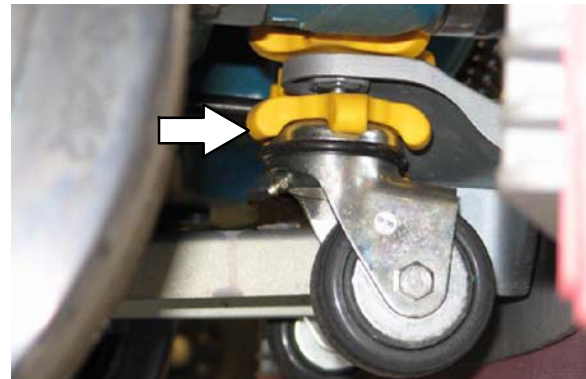

5. Retighten the lock knob.
6. Drive the machine forward again to recheck the squeegee blade deflection.
7. Readjust the squeegee blade deflection if necessary.

REPLACING OR ROTATING THE SIDE SQUEEGEE BLADES

1. If necessary, raise the scrub head.

FOR SAFETY: Before leaving or servicing machine, stop on level surface, turn off machine, and remove key.

2. Open the main brush access door and side squeegee support door.



3. Unhook the retaining band latch from the side squeegee assembly.



4. Remove the retaining band from the side squeegee assembly.



5. Remove the squeegee blade from the side squeegee assembly.



6. Install the rotated or new rear squeegee blade onto the side squeegee assembly.

7. Hook the retaining band onto the retaining band retainer tab on the side squeegee assembly.



8. Fasten the retaining band latch onto the side squeegee assembly.



9. Close and secure the squeegee support door and close the main brush access door.

10. Repeat for the side squeegee on the other side of the scrub head.

MAINTENANCE

REPLACING OR ROTATING THE SIDE BRUSH SQUEEGEE BLADES (OPTION)

FOR SAFETY: Before leaving or servicing machine, stop on level surface, turn off machine, and remove key.

Check the side brush squeegee blade for damage and wear daily. Replace or rotate the blade if the leading edge is torn or worn half-way through the thickness of the blade.

1. Loosen the side brush squeegee assembly handle and remove the squeegee assembly from the machine.



2. Loosen the retaining band latch.



3. Remove the retaining band, squeegee blades, and spacer from the squeegee frame.



NOTE: Observe which squeegee slots were installed on the squeegee frame before removing the squeegee.



NOTE: The squeegee blade(s) have two sets of slots for adjusting the squeegee blade deflection. Install / reinstall squeegees so the deflection is approximately 12 mm (0.50 in) for smooth floors and 15 mm (0.62 in) for rough floors.

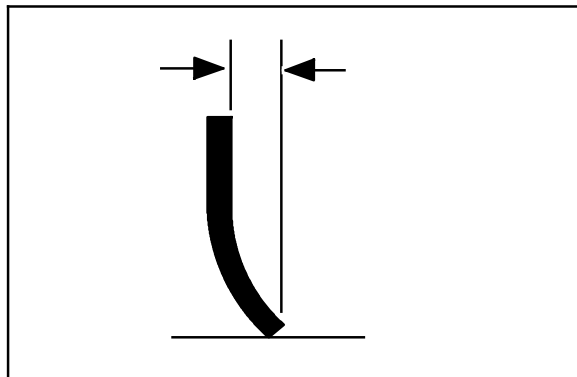

4. Install the rotated / new squeegee blades, spacer, and retaining band onto the side brush assembly.



5. Fasten the side brush retaining band latch.



6. Reinstall the side brush squeegee assembly onto the side brush assembly.

MAINTENANCE

SKIRTS AND SEALS

FOR SAFETY: Before leaving or servicing machine, stop on level surface, turn off machine, and remove key.

RECOVERY TANK SEAL

Check the recovery tank cover seal for damage and wear daily.

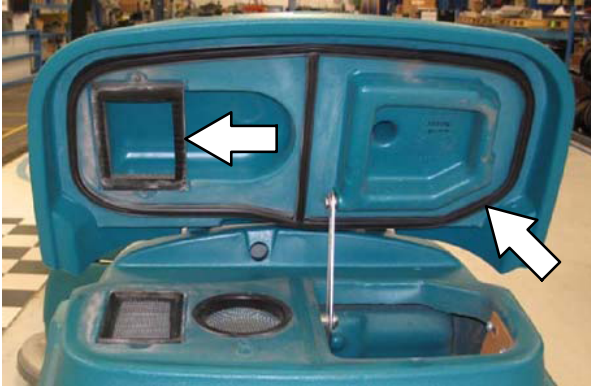

SCRUB HEAD SKIRTS (DISK SCRUB HEADS ONLY)

Check the scrub head skirts for damage and wear after every 50 hours of operation.

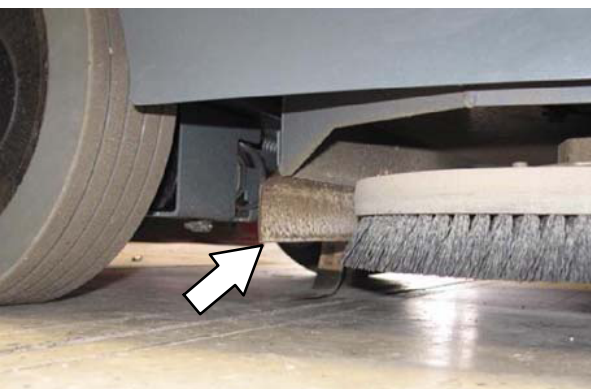
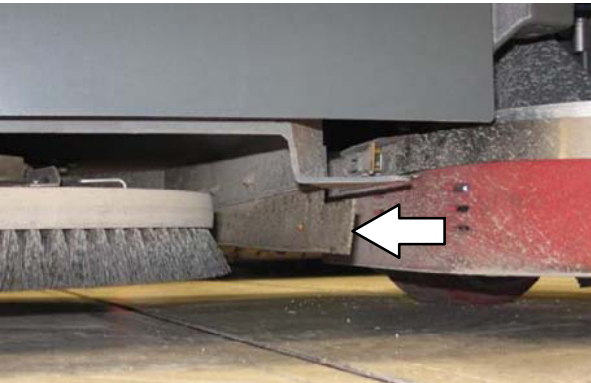

BELTS

CYLINDRICAL BRUSH DRIVE BELTS

FOR SAFETY: Before leaving or servicing machine, stop on level surface, turn off machine, and remove key.

The brush drive belts are located on the cylindrical brush scrub head. Check the belts for damage and wear after every 200 hours of operation.

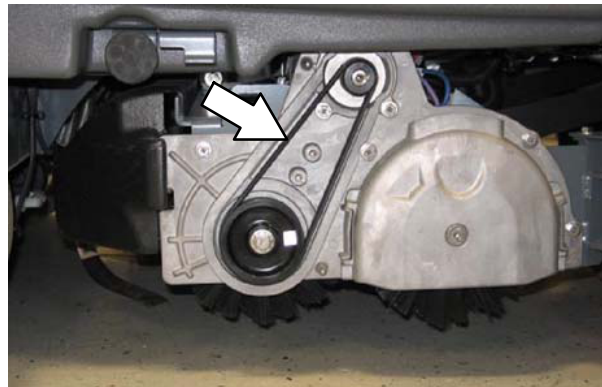

TIRES

FOR SAFETY: Before leaving or servicing machine, stop on level surface, turn off machine, and remove key.

The machine has three solid rubber tires: one in front, and two in the rear of the machine. Check tires for damage and wear after every 500 hours of operation.

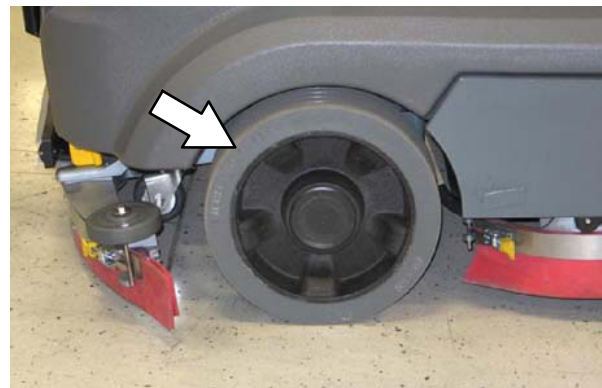

PUSHING, TOWING, AND TRANSPORTING THE MACHINE

PUSHING OR TOWING THE MACHINE

If the machine becomes disabled, it can be pushed or towed from the front or rear.

The parking brake must be disabled before towing or pushing the machine. To disable the brake, insert the tip of a small screw driver between the electronic brake lever and the hub. The machine can move freely when the parking brake is disabled.



Only push or tow the machine for a *very short distance* and do not exceed 3.2 kp/h (2 mph). It is NOT intended to be pushed or towed for a long distance or at a high speed.

ATTENTION! Do not push or tow machine for a long distance or damage may occur to the propelling system.

Immediately after pushing the machine, remove the screw driver from between the electronic brake lever and the hub. NEVER operate the machine with the parking brake disabled.

FOR SAFETY: Do not operate machine with brake disabled.

TRANSPORTING THE MACHINE

1. Raise the squeegee, scrub head, and brushes.

FOR SAFETY: When loading/unloading machine onto/off truck or trailer, drain tanks before loading machine.

2. Position the machine at the loading edge of the truck or trailer.

3. If the loading surface is not horizontal or is higher than 380 mm (15 in) from the ground, use a winch to load machine.

If the loading surface is horizontal AND is 380 mm (15 in) or less from the ground, the machine may be driven onto the truck or trailer.

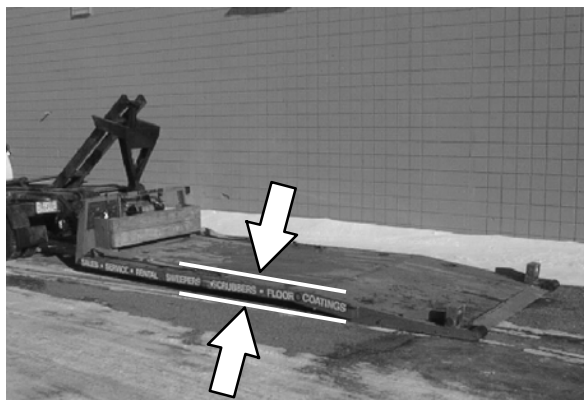

FOR SAFETY: When loading machine onto truck or trailer, use winch. Do not drive the machine onto the truck or trailer unless the loading surface is horizontal AND is 380 mm (15 in) or less from the ground.

4. To winch the machine onto the truck or trailer, attach the winching chains to the stabilizer legs.



5. Position the machine as close to the front of the trailer or truck as possible. If the machine starts to veer off the center line of the truck or trailer, stop and turn the steering wheel to center the machine.

MAINTENANCE

6. Place a block behind each wheel to prevent the machine from rolling.
7. Lower the scrub head and turn off machine.

FOR SAFETY: When loading/unloading machine onto/off truck or trailer, lower scrub head and squeegee before tying down machine.

8. Connect the tie-down straps to the right and left stabilizer bars in front of the machine and the holes in the rear jacking brackets at the rear of the machine.

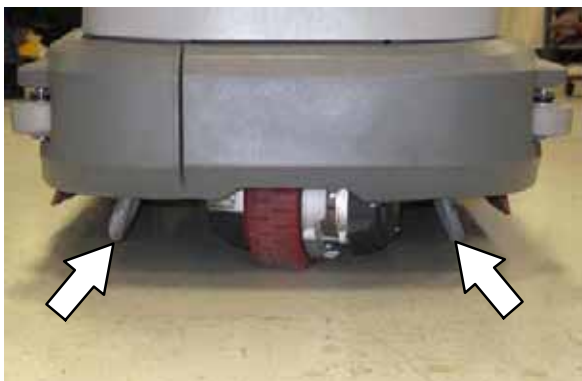

9. If the loading surface is not horizontal or is higher than 380 mm (15 in) from the ground, use a winch to unload machine.

If the loading surface is horizontal AND is 380 mm (15 in) or less from the ground, the machine may be driven off the truck or trailer.

FOR SAFETY: When unloading machine off truck or trailer, use winch. Do not drive the machine off the truck or trailer unless the loading surface is horizontal AND 380 mm (15 in) or less from the ground.

MACHINE JACKING

FOR SAFETY: Before leaving or servicing machine, stop on level surface, turn off machine, and remove key.

Empty the recovery and solution tanks before jacking the machine.

Jacking point location at the front of all machines.

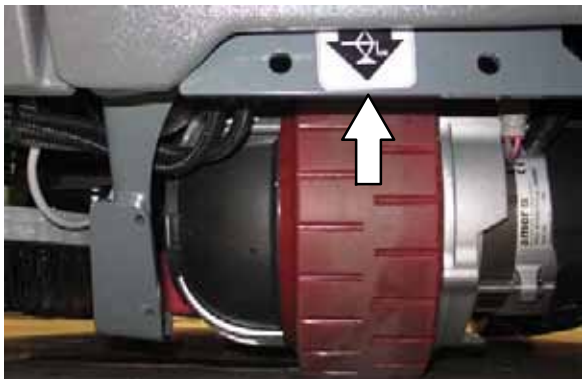

Jacking point location at the rear of machines not equipped with the optional rear squeegee protector.



Jacking point location at the rear of machines equipped with the optional rear squeegee protector.



FOR SAFETY: When servicing machine, block machine tires before jacking machine up. Use a hoist or jack that will support the weight of the machine. Jack machine up at designated locations only. Support machine with jack stands.

MAINTENANCE

***ec-H2O* MODULE FLUSH PROCEDURE**

This procedure is only required when an alarm sounds and the *ec-H2O* system indicator light begins to blink.

FOR SAFETY: Before leaving or servicing machine, stop on level surface and turn off machine.

1. Lift the operator seat open and engage the seat support.
2. Remove the drain hose from the *ec-H2O* compartment.



3. Press the connector button to disconnect the outlet hose from the *ec-H2O* manifold.



4. Connect the drain hose to the *ec-H2O* manifold hose disconnected from the *ec-H2O* manifold in the previous step.



5. Place the drain hose into a empty container.



6. Pour 2 gallons (7.6 liters) of white or rice vinegar into the solution tank.

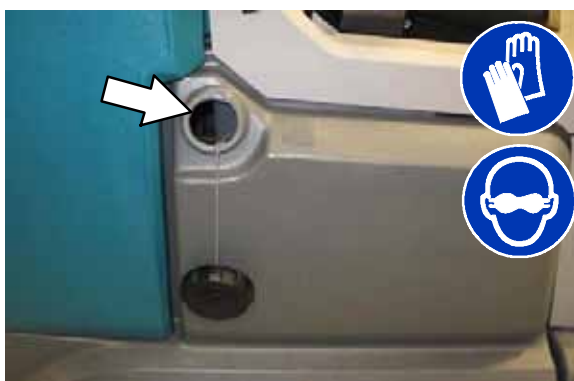

7. Start the machine.
8. Press and release the *ec-H2O* module flush switch to start the flush cycle.



NOTE: The module will automatically shut off when the flush cycle is complete (approximately 7 minutes). The module must run the full 7-minute cycle in order to reset the system indicator light and alarm.

9. Pour 2 gallons (7.6 liters) of cool clean water into the solution tank.
10. Press and release the flush switch to rinse any remaining vinegar from the module. After 1-2 minutes, press the flush switch to turn off the module.
11. Disconnect the drain hose from the *ec-H2O* manifold hose.
12. Reconnect the outlet hose to the the scrub head to the *ec-H2O* manifold.
13. Place the drain hose back into the *ec-H2O* compartment.
14. Close the operator seat.

MAINTENANCE

STORAGE INFORMATION

The following steps should be taken when storing the machine for extended periods of time.

1. Charge the batteries before storing machine to prolong the life of the batteries.
2. Thoroughly drain and rinse the solution and recovery tanks.
3. Store the machine in a dry area with the squeegee and scrub head in the up position.

ATTENTION: Do not expose machine to rain, store indoors.

4. Open the recovery tank cover to promote air circulation.
5. If storing machine in freezing temperatures, proceed to **FREEZE PROTECTION**.

NOTE: To prevent potential machine damage store machine in a rodent and insect free environment.

FREEZE PROTECTION

FOR SAFETY: Before leaving or servicing machine, stop on level surface and turn off machine.

1. Completely drain the solution tank and recovery tank.
2. Pour 7.6 L (2 gal) of Propylene Glycol Based / Recreational Vehicle (RV) antifreeze into the solution tank.



3. Turn on the machine.

4. Press the *1-Step button*.



T12

T12XP

5. Repeatedly press the *Solution increase button (+)* until the solution flow is at the highest setting.

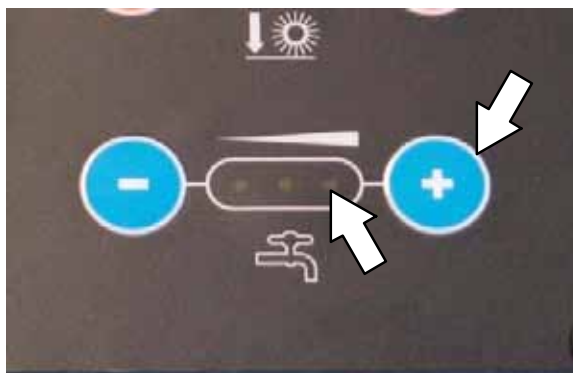

T12



T12XP

6. **Machines with *ec-H2O* option only:** Press the *scrub mode button* to place machine into the *ec-H2O* mode. The *ec-H2O* indicator light will illuminate.



T12

T12XP

7. **Machines with *side brush* option only:** Press the *side brush switch* to activate the side brush.



T12



T12XP

8. Drive the machine to circulate the RV antifreeze completely through all the systems and clear out any remaining water.

9. **Machines with *side brush* option only:** Press the *side brush switch* to turn off the side brush.

10. Stop the machine.

11. **Machines with *spray nozzle* option only:** Operate the wand for a few seconds to protect the pump.

12. Press the *1-STEP button* to turn off the system.

13. Turn off the machine.

14. The remaining RV antifreeze does not need to be drained from the solution or recovery tank.

MAINTENANCE

PREPARING THE MACHINE FOR OPERATION AFTER STORAGE

All Propylene Glycol Based / Recreational Vehicle (RV) Antifreeze must be completely cleaned from the scrubbing system before the machine can be used for scrubbing.

FOR SAFETY: Before leaving or servicing machine, stop on level surface and turn off machine.

1. Completely drain all Propylene Glycol Based / Recreational Vehicle (RV) antifreeze from the solution tank.
2. Rinse out the solution tank. Refer to *DRAINING AND CLEANING THE SOLUTION TANK* in the *OPERATION* section for instructions how to clean the solution tank.
3. Pour 11.4 L (3 gal) of cool clean water into the solution tank.



4. Start the machine
5. Press the *1-STEP* button.



T12

T12XP

6. Repeatedly press the *Solution increase* button (+) until the solution flow is at the highest setting.

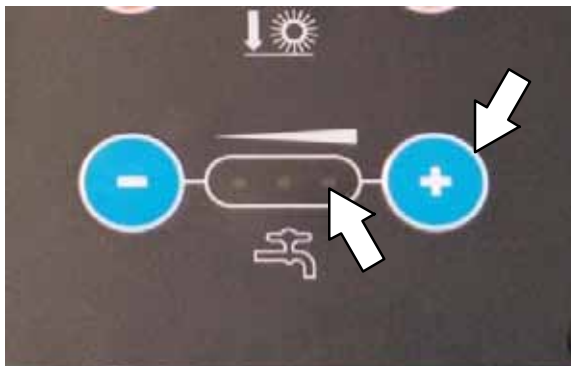

T12



T12XP

7. **Machines with *ec-H2O* option only:** Press the *scrub mode* button to place machine into the *ec-H2O* mode. The indicator light will illuminate.



T12

T12XP

NOTE: The *ec-H2O* systems on machines equipped with *ec-H2O* must be primed before the machine is ready for operation. See *PRIMING THE ec-H2O SYSTEM* for additional instructions.

8. **Machines with side brush option only:**
Press the *side brush switch* to activate the side brush.

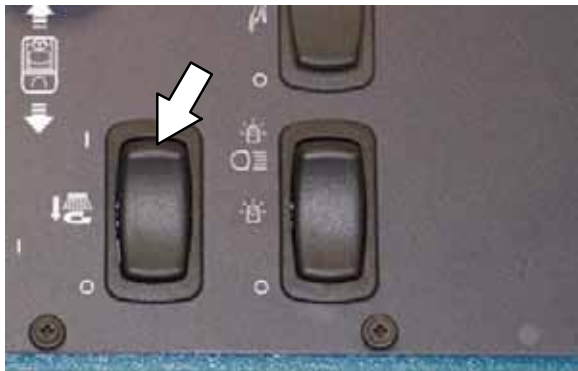

T12

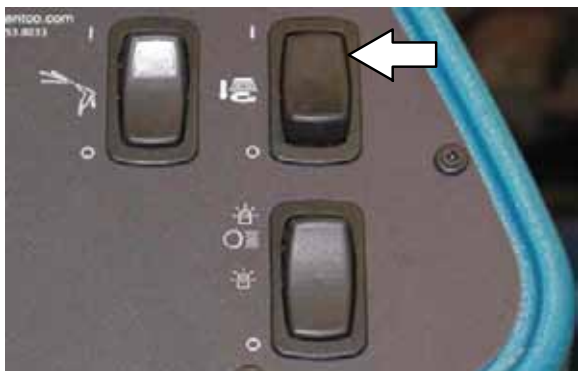

T12XP

9. Drive the machine to circulate the clean water completely through the system and clear out the RV antifreeze.
10. **Machines with side brush option only:**
Press the *side brush switch* to turn off the side brush.
11. Stop the machine.
12. **Machines with spray nozzle option only:**
Operate the wand for a few seconds to clean the RV antifreeze from the pump.
13. Press the *1-STEP button* to turn off the system.
14. Turn off the machine.
15. The remaining water does not need to be drained from the solution tank.

MAINTENANCE

PRIMING THE *ec-H2O* SYSTEM

Prime the *ec-H2O* system if the machine has been stored for a long period with no water in the solution tank / *ec-H2O* system.

FOR SAFETY: Before leaving or servicing machine, stop on level surface and turn off machine.

1. Fill the solution tank with clean cool water. See *FILLING THE SOLUTION TANK* section of this manual.



2. Lift the operator seat open and engage the seat support.
3. Remove the drain hose from the *ec-H2O* compartment.



4. Disconnect the outlet hose to the scrub head from the *ec-H2O* manifold.

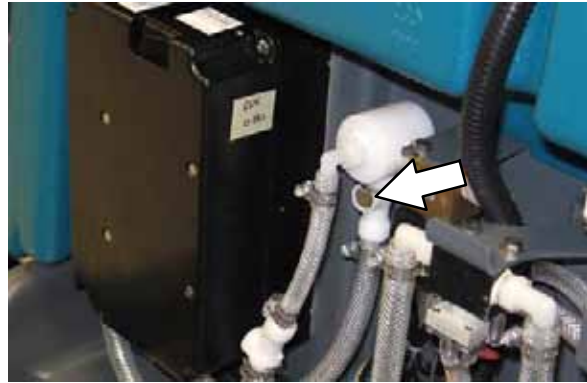

5. Place the drain hose into an empty container.
6. Connect the drain hose to the *ec-H2O* manifold hose disconnected from the outlet hose in the previous step.



7. Place the *ec-H2O* system outlet hose into an empty container.



8. Start the machine.

9. Press and release the *ec-H2O* module flush switch. Allow the system to drain water into the container for 2 minutes.

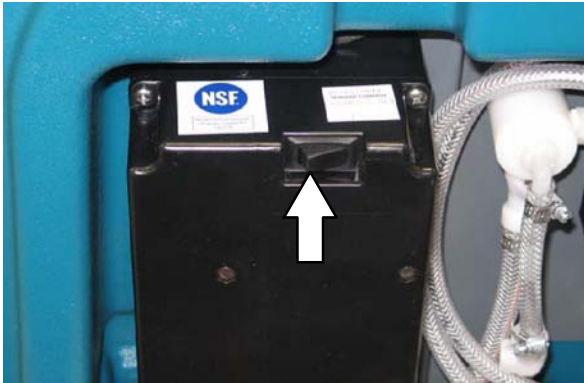

10. Press the *ec-H2O* module flush switch to shut off the system.
11. Disconnect the drain hose from the *ec-H2O* manifold hose.
12. Reconnect the outlet hose to the scrub head to *ec-H2O* manifold hose.
13. Place the drain hose back into the *ec-H2O* compartment.
14. Close the operator seat cover.

SECTION 4

Contents	Page
TROUBLESHOOTING	
ONBOARD DIAGNOSTICS	4-2
SELF-TEST MODE	4-2
CONFIGURATION MODE	4-4
LCD WARNINGS.....	4-6
LCD FAULTS.....	4-7
PROPEL DIAGNOSTIC MODE.....	4-9
CURTIS 1232 CONTROLLER	
DIAGNOSTICS	4-11
DIAGNOSTIC LED OPERATION.....	4-11
DIAGNOSTIC CODES.....	4-12
INPUT DISPLAY MODE	4-20
MANUAL MODE	4-22
CAN (CONTROLLER AREA NETWORK)	
DIAGNOSTIC MODE.....	4-24
FIRMWARE UPDATE MODE.....	4-25
BATTERY CHARGER, STANDARD.....	4-26
OPERATION.....	4-26
CONFIGURATION	4-26
FAULTS	4-26
BATTERY CHARGER, ONBOARD OPT....	4-27
OPERATION	4-27
CONFIGURATION.....	4-27
FAULTS.....	4-27
SUBSYSTEM TROUBLESHOOTING	4-28
BACK-UP ALARM/LIGHT	4-28
BATTERY CHARGING.....	4-30
ONBOARD.....	4-30
OFF BOARD.....	4-32
PARKING BRAKE, ELECTROMAGNETIC..	4-34
LIGHTING.....	4-36
MAIN SCRUB BRUSHES	4-38
POWER-UP	4-40
PROPEL.....	4-42
REAR SQUEEGEE LIFT	4-44
SCRUB HEAD LIFT	4-46
SIDE BRUSH	4-48
SIDE BRUSH LIFT.....	4-50
SOLUTION CONTROL, CONVENTIONAL	4-54
MAIN BRUSH	4-54
SIDE BRUSH	4-56
SOLUTION CONTROL, ECH2O.....	4-58
SPRAY NOZZLE	4-60
VACUUM FAN.....	4-62

TROUBLESHOOTING

SELF TEST MODE

Self Test Mode is an onboard diagnostic utility that tests for open or shorted output circuits. Once completed, open and/or shorted output pins are displayed on the LCD (liquid crystal display).

1. Key switch Off. Press and hold the configuration mode button.

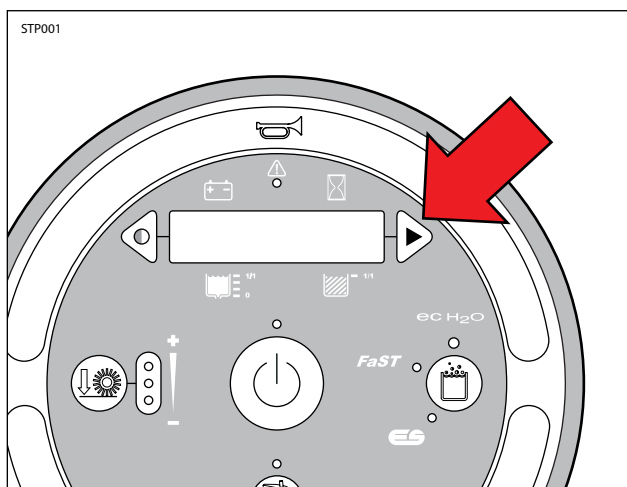

2. Key switch On. Release the configuration mode button when "CONFIG MODE" appears on the LCD.

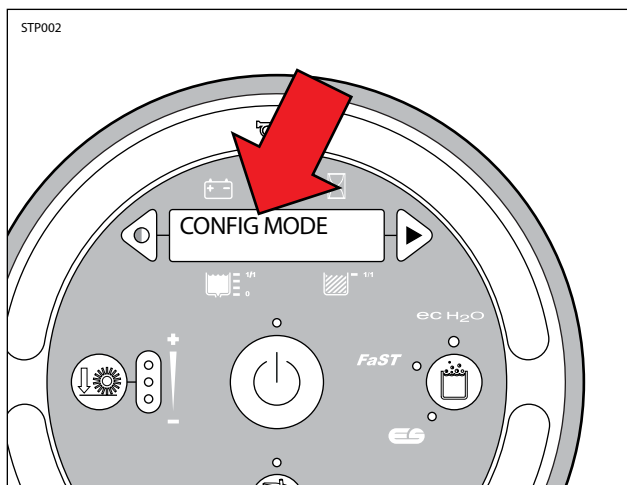

3. Press and release the configuration mode button to scroll through a list of utilities until "SELF TEST" appears on the LCD.

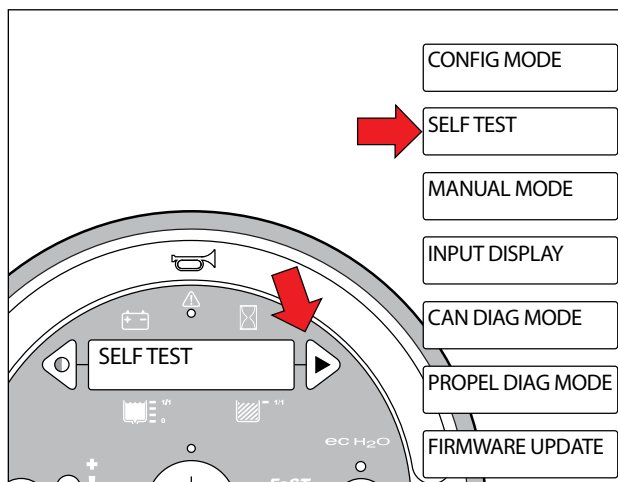

4. Press and release the brush pressure button to activate the self test. "SELF-TEST STARTING" will appear on the LCD.

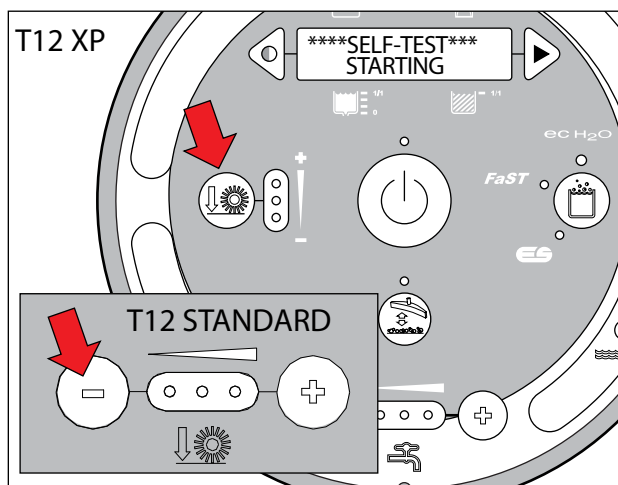

5. The controller sequentially tests each output circuit as shown below.

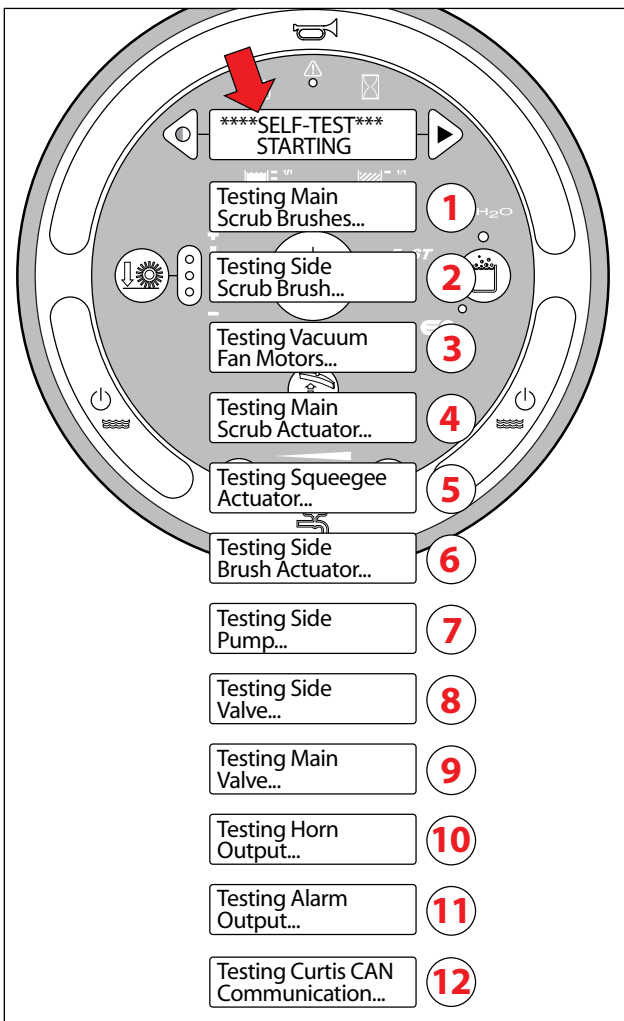

6. The self test results are displayed in "JX-X,X" format. JX = Connector, "-X,X" = Control board output pins as shown on the electrical schematic.

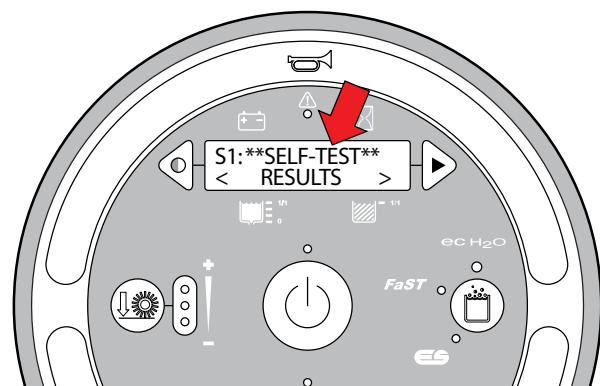

T12 Self Test Codes

CODE	LCD MESSAGE	CODE	LCD MESSAGE
S1	S1:Self Test "Done" or "<Results>"	S19	S19:Side Brush J3-2,3/Short
S2	S2:Front/Left Br J5-1,2/Open	S20	S20:Side Act J5-2,3/Open
S3	S3:Front/Left Br J5-1,2/Short	S21	S21:Side Act J5-2,3/Short
S4	S4:Rear/Right Br J5-4,5/Open	S22	S22:Side Pump J5-5/Open
S5	S5:Rear/Right Br J5-4,5/Short	S23	S23:Side Pump J5-5/Short
S6	S6:Main Act J6-7,8/Open	S24	S24:Side Valve J5-4/Open
S7	S7:Main Act J6-7,8/Short	S25	S25:Side Valve J5-4/Short
S8	S8:Main Valve J6-2/Open	S34	S34:Ec-H2O Pump J4-4/Open
S9	S9:Main Valve J6-2/Short	S35	S35:Ec-H2O Pump J4-4/Short
S10	S10:Horn J6-3/Open	S36	S36:Ec-H2O Side Br. J4-5/Open
S11	S11:Horn J6-3/Short	S37	S37:Ec-H2O Side Br. J4-5/Short
S12	S12:Alarm J6-4/Open	S38	S38:Curtis CAN/J6-13,14 No Comm
S13	S13:Alarm J6-4/Short	S50	S50:Scrub Module/Offline
S14	S14:Vac Fan J3-2,3/Open	S51	S51:Pickup Module/Offline
S15	S15:Vac Fan J3-2,3/Short	S52	S52:ECH2O Module/Offline
S16	S16:Sqge Act. J5-2,3/Open	S53	S53:Side Module/Offline
S17	S17:Sqge Act. J5-2,3/Short		
S18	S18:Side Brush J3-2,3/Open		

TROUBLESHOOTING

CONFIGURATION MODE

Configuration Mode is an onboard diagnostic utility that configures controller software to operate optional equipment and to electronically adjust certain output functions.

1. Key switch Off. Press and hold the configuration mode button.

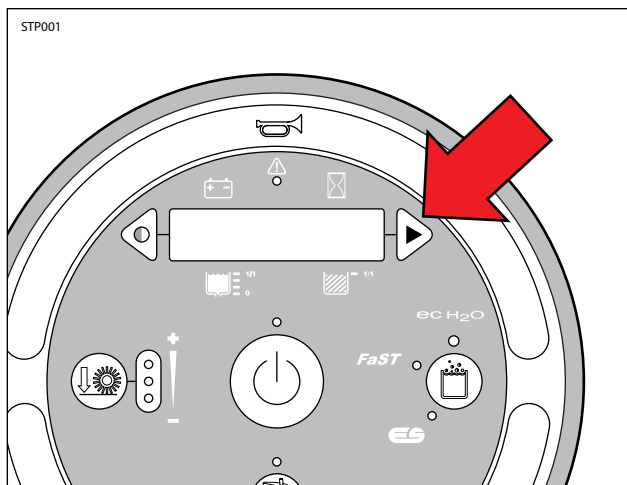

2. Key switch On. Release the configuration mode button when "CONFIG MODE" appears on the LCD.

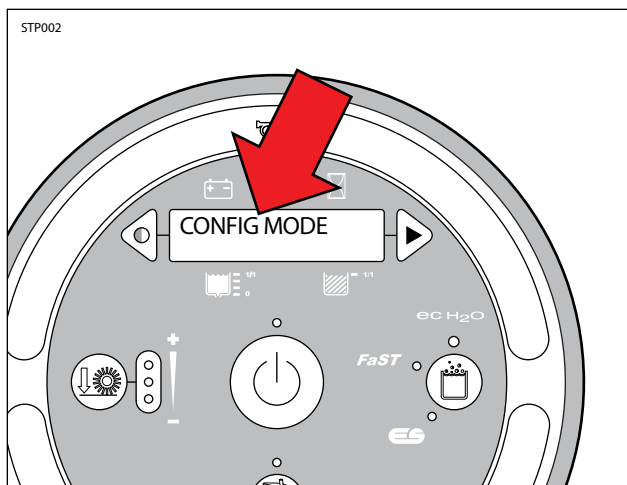

3. Press and release the brush pressure button to enter Configuration Mode. "C1:Disk/Cyl" will appear on the LCD.

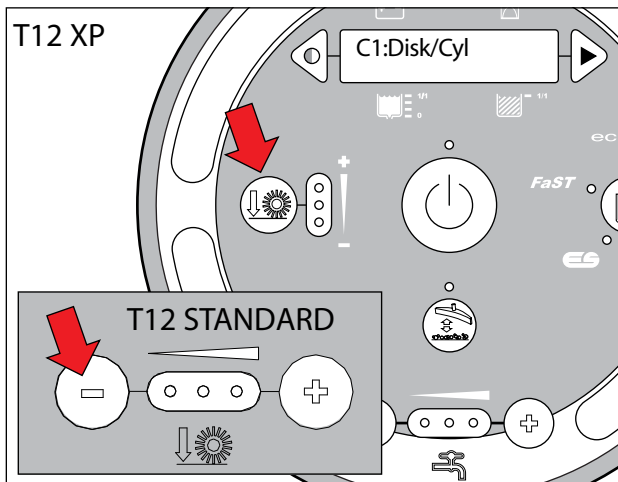

4. Press and release the configuration mode button to scroll through a list of utilities as shown below.

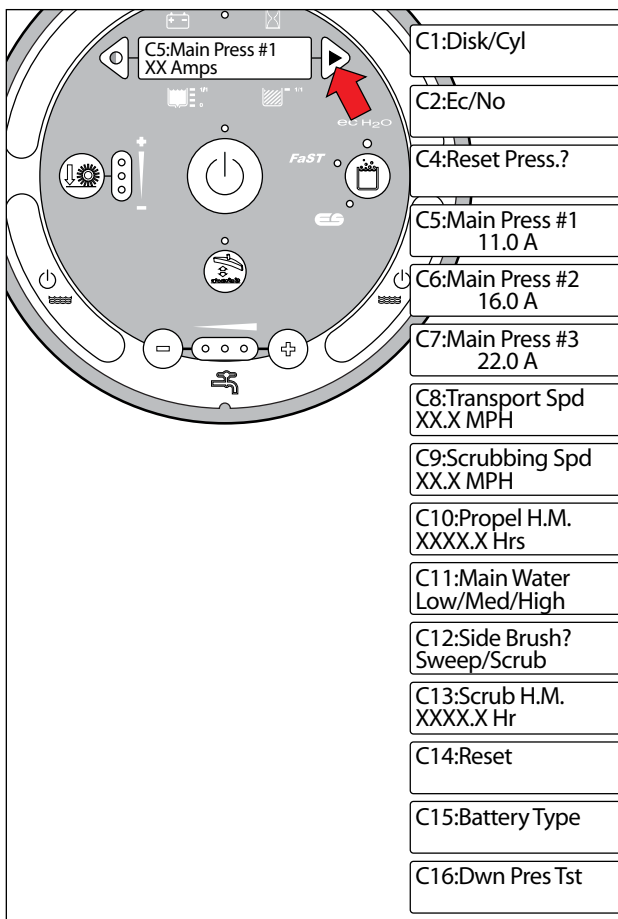

5. Use the table below for further description of each Configuration Mode utility.

LCD TEXT	DESCRIPTION
C1:Disk/Cyl	Configure scrub head type
C2:Ec/No	Configure ec-H2O or none
C4:Reset Press.? [*]	Restore down pressure settings
C5:Main Press #1 ^{**}	Set max down pressure #1 (11 Amps-Fixed)
C6:Main Press #2 ^{**}	Set max down pressure #2 (11-16 Amps, Default 16 Amps)
C7:Main Press #3 ^{**}	Set max down pressure #3 (11-22 Amps, Default 22 Amps)
C8:Transport Spd XX.X MPH	Adjust maximum forward transport mode speed
C9:Scrubbing Spd XX.X MPH	Adjust maximum forward scrub mode speed
C10:Propel H.M. XXXX.X Hrs	Display/edit propel hour meter. Password protected
C11:Main Water	Select water flow range: (Low, Medium, High)
C12:Side Brush?	Configure side brush option
C13:Scrub H.M. XXXX.X Hr	Display/edit scrub hour meter. Password protected
C14:Reset	Restore factory default values.
C15:Battery Type	Configure battery type for acid or AGM
C16:Dwn Pres Tst ^{***}	Initiate brush pattern testing (Disable/Enable)

^{*} C4:Reset Press.? mode. Press the brush pressure button after "No" changes to "Yes" following step 7. This completes the reset process.

^{**} C5, C6, and C7 Main Press (Main Brush Pressure) adjustments set the maximum brush motor amp draw for each down pressure setting; 1 LED, 2 LEDs, or 3 LEDs. C5 (#1) down pressure is not adjustable.

^{***} C16 Dwn Pres Tst (Down Pressure Test) pertains to checking the cylindrical scrub brush pattern. See CHECKING CYLINDRICAL SCRUB BRUSH PATTERN in the MAINTENANCE section of this manual.

6. Press and release the brush pressure button to enable the change. A "<" symbol will appear on the bottom line of the LCD indicating the configuration utility is now enabled.

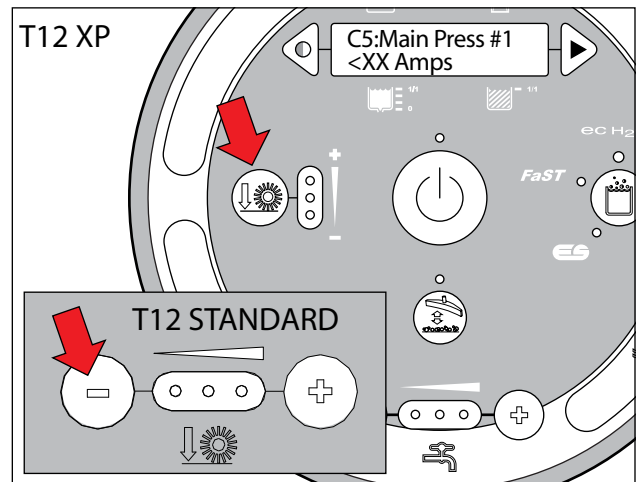

7. Press and release the contrast or configuration mode buttons to change settings. Turn key Off to save selection.

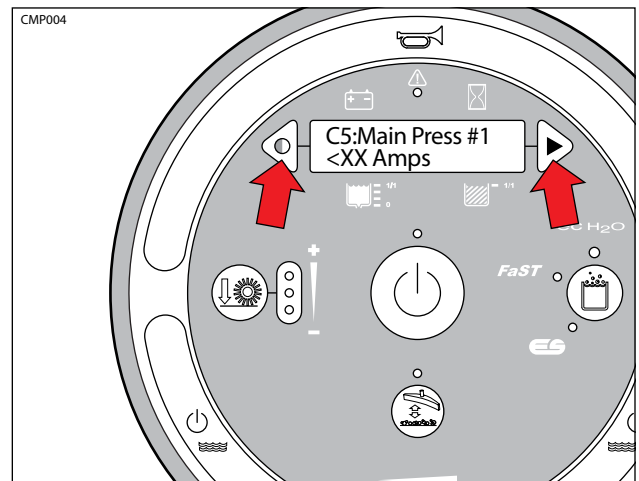

TROUBLESHOOTING

T12 LCD Warning Messages

WARNING CODE	WARNING MESSAGE	WARNING DESCRIPTION	SET/CLEAR
W1	W1:Batt Low	Low Battery	<i>SET:</i> Battery discharge threshold of 30-32 Volts at KSI terminal or 32-33 Volts at batteries. <i>CLEAR:</i> Charge batteries to BDI reset threshold of 37 Volts at KSI terminal or 38 Volts at batteries
W2	W2:Sqge Stall	Rear Squeegee Actuator Stalled	<i>SET:</i> Rear squeegee actuator stall condition. <i>CLEAR:</i> Correct warning condition.
W3	W3:Side Stall	Side Brush Actuator Stalled	<i>SET:</i> Side brush actuator stall condition. <i>CLEAR:</i> Correct warning condition.
W4	W4:Unavailable	No Optional Solution Enabled	<i>SET:</i> Operator selects a solution technology that is not configured on the machine. <i>CLEAR:</i> Release button.
W5	W5:No Side Brush	No Side Brush Enabled	<i>SET:</i> Operator selects the side brush when the side brush is not enabled in configuration mode. <i>CLEAR:</i> Release button.
W6	W6: Ec Offline	Ec-H2O Module Offline	<i>SET:</i> Ec-H2O technology is configured and there is no CAN connectivity to the ec-H2O module. <i>CLEAR:</i> Correct warning condition.
W7	W7:Not Active	Inactive Button	<i>SET:</i> Operator selects a button and the related function is inactive. <i>CLEAR:</i> Correct warning condition.
W8	W8:No Vac Amps	Vacuum Fan Motor, No Current	<i>SET:</i> Controller senses no current to the vacuum fan circuit when the output is turned ON. <i>CLEAR:</i> Correct open circuit condition.
W9	W9:Open R/R Brush	Open Right/Rear Brush Motor	<i>SET:</i> Controller senses no current to the Right (Disk) or Rear (Cyl) motor circuit when the output is turned ON. <i>CLEAR:</i> Correct open circuit condition.
W10	W10:Open L/F Brush	Open Left/Front Brush Motor	<i>SET:</i> Controller senses no current to the Left (Disk) or Front (Cyl) motor circuit when the output is turned ON. <i>CLEAR:</i> Correct open circuit condition.
W11	W11:Open SD Brush	Open Side Brush Motor	<i>SET:</i> Controller senses no current to the side brush motor circuit when the output is turned ON. <i>CLEAR:</i> Correct open circuit condition.
W12	W12:Solution Off	Solution Water is Off	<i>SET:</i> Solution is OFF during scrub mode for 15 seconds. <i>CLEAR:</i> Correct warning condition.
W13	W13: Side Offline	Side Module Offline	<i>SET:</i> Side brush is configured and there is no CAN connectivity to the side brush module. <i>CLEAR:</i> Correct warning condition.

MM001

Terms:

KSI = Key Switch Interlock

BDI = Battery Discharge Indicator

T12 LCD Fault Messages

FAULT CODE	FAULT MESSAGE	FAULT DESCRIPTION	SET/CLEAR
F1	F1:Rcv Tank Full	Recovery Tank Full	<i>SET:</i> Recovery tank full for 5 seconds. <i>CLEAR:</i> Recovery tank not full for 5 seconds.
F2	F2:SolTank Empty	Solution Tank Empty	<i>SET:</i> Solution tank empty for 60 seconds <i>CLEAR:</i> Cycle key switch.
F3	F3:Vac#Flt#	Over Current Vacuum Fan # (1 or 2) Motors, Fault Type (1, 2, 3).	<i>SET:</i> Fault #1 = Over Current for 15 Seconds; Fault #2 = Current Exceeds 25A for 30 Seconds; Fault #3 = Current Exceeds 35A for 2 Seconds. <i>CLEAR:</i> Cycle key switch.
F4	F4:Batt Very Low	Very Low Battery Voltage	<i>SET:</i> Battery discharge threshold of 30.2 Volts at KSI terminal of PMC or 31.6 Volts at battery. <i>CLEAR:</i> Charge batteries to BDI reset threshold of 37 Volts at KSI terminal of PMC or 38.3 Volts at batteries.
F5	F5:Propel Error	Propel Controller CAN-bus Connectivity Error	<i>SET:</i> Curtis 1232 PMC to T12 logic board CAN-bus connectivity problem or Curtis 1232 PMC power supply problem. <i>CLEAR:</i> See "Curtis 1232 Controller Diagnostics."
F6	F6:Left Br Flt#	Left Brush Over Current, Fault #	<i>SET:</i> Fault #1 = Current Exceeds 30A for 30 Seconds; Fault #2 = Current Exceeds 40A for 5 Seconds; Fault #3 = Over Current for 10 Seconds. <i>CLEAR:</i> Cycle key switch.
F6	F6:Frnt Br Flt#	Front Brush Over Current, Fault #	<i>SET:</i> Fault #1 = Current Exceeds 30A for 30 Seconds; Fault #2 = Current Exceeds 40A for 5 Seconds; Fault #3 = Over Current for 10 Seconds. <i>CLEAR:</i> Cycle key switch.

Terms:

KSI = Key Switch Interlock

PMC = Propel Motor Control

TROUBLESHOOTING

T12 LCD Fault Messages, continued

FAULT CODE	FAULT MESSAGE	FAULT DESCRIPTION	SET/CLEAR
F7	F7:Right Br Flt#	Right Brush Over Current, Fault #	SET: Fault #1 = Current Exceeds 30A for 30 Seconds; Fault #2 = Current Exceeds 40A for 5 Seconds; Fault #3 = Over Current for 10 Seconds. CLEAR: Cycle key switch.
F7	F7:Rear Br Flt#	Rear Brush Over Current, Fault #	SET: Fault #1 = Current Exceeds 30A for 30 Seconds; Fault #2 = Current Exceeds 40A for 5 Seconds; Fault #3 = Over Current for 10 Seconds. CLEAR: Cycle key switch.
F8	F8:Hi B3 Current	Over Current for Side Brush Motor	SET: Fault #1 = Current Exceeds 30A for 30 Seconds; Fault #2 = Current Exceeds 40A for 5 Seconds; Fault #3 = Over Current for 10 Seconds. CLEAR: Cycle key switch.
F9	F9:Pickup Error	Pickup module CAN Fault	SET: CAN connectivity to pickup module failed. CLEAR: Correct fault condition and cycle key switch.
F10	F10:Scrub Error	Scrub module CAN Fault	SET: CAN connectivity to scrub module failed. CLEAR: Correct fault condition and cycle key switch.
F11	F11:Act Timeout	Main Head Actuator Timed Out Fault.	SET: Unable to achieve target brush motor current after 60 seconds of actuator adjustments. CLEAR: Correct fault condition and cycle key switch or 1-STEP scrub.
F12	F12:Check Brushes	Check Main Brushes Error Fault (Down Shift)	SET: Controller failed to achieve minimum target brush motor current after down shifting to the lowest down pressure setting. CLEAR: Correct fault condition and cycle key switch.
F13	F13:Brush Motor Flt	Brush Motor Fault	SET: Head lift actuator stalled while trying to reduce down pressure. CLEAR: Cycle key switch or 1-STEP scrub.
F14	F14:EcH2O Error	Ec-H2O Module CAN Fault	SET: CAN connectivity to ec-H2O module failed. CLEAR: Correct fault condition and cycle key switch.

FMM002

Terms:
KSI = Key Switch Interlock

PROPEL DIAGNOSTIC MODE

Propel Diagnostic Mode (Propel Input Mode) is an on-board diagnostic utility that displays Curtis 1232 control inputs on the instrument panel LCD (Liquid Crystal Display). The input data is transmitted to the T12 controller through a CAN-bus (Controller Area Network).

1. Key switch Off. Press and hold the configuration mode button.

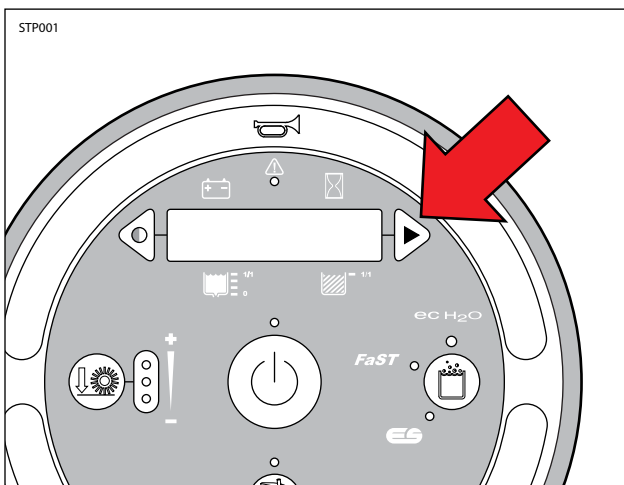

2. Key switch On. Release the configuration mode button when "CONFIG MODE" appears on the LCD.

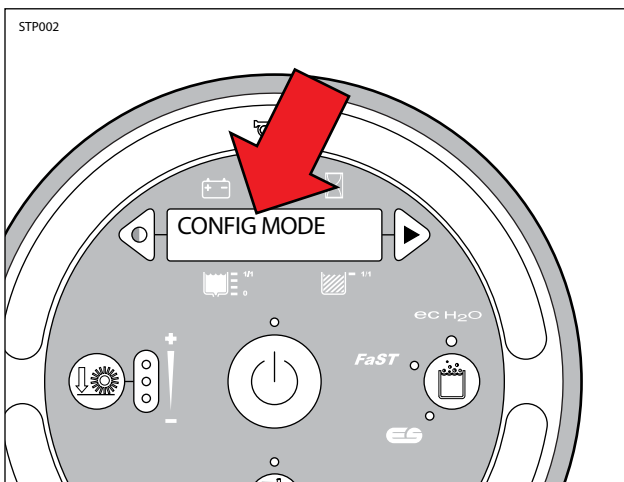

3. Press and release the configuration mode button to scroll through a list of utilities until "PROPEL DIAG MODE" appears on the LCD.

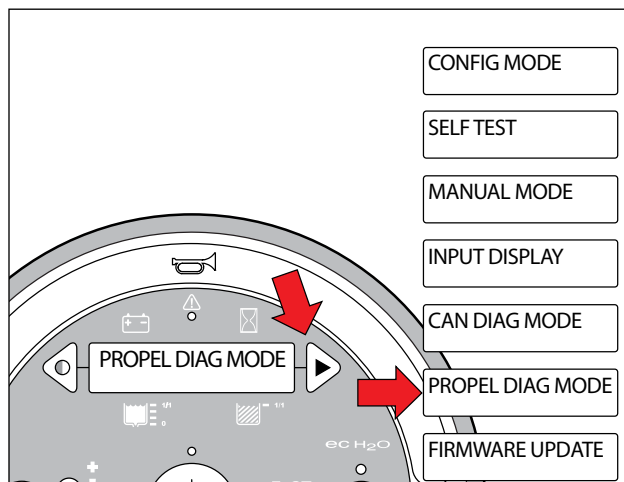

4. Press and release the brush pressure button to enter Propel Diagnostic Mode. "P1:Curtis Online..." will appear on the LCD.

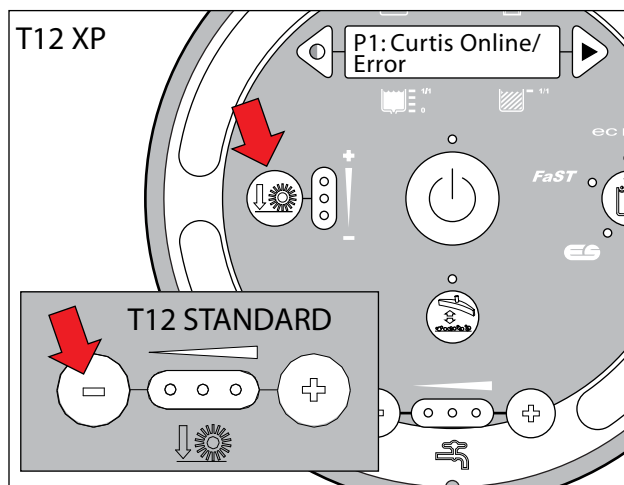

TROUBLESHOOTING

5. Press and release the configuration mode button to scroll through a list of Curtis 1232 controller inputs.

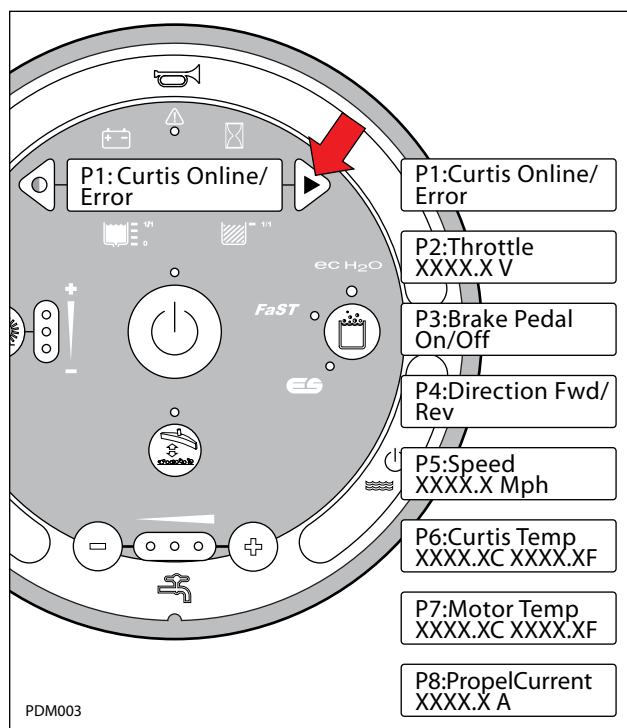

6. The table below describes how each input operates.

T12 Propel Diagnostic Mode		
CODE	LCD MESSAGE	DESCRIPTION
P1	P1:Curtis Online/Error	Curtis/T12 controllers CAN-bus connection status
P2	P2:Throttle XXXX.X v	Displays foot throttle commanded voltage (0-5V).
P3	P3:Brake Pedal On/Off	Displays brake pedal command (On/Off).
P4	P4:Direction Fwd/Rev	Displays directional switch input (Fwd/Rev).
P5	P5:Speed XXXX.X Mph	Displays propel speed from motor encoder located in drive assembly.
P6	P6:Curtis Temp XXXX.XC XXXX.XF	Displays Curtis 1232 controller temperature
P7	P7:Motor Temp XXXX.XC XXXX.XF	Displays drive motor temperature. Thermistor located in drive assembly.
P8	P8:PropelCurrent XXXX.X A	Displays propel motor current.

PDM004

Curtis 1232 Controller Diagnostic LED Operation

PMCO02

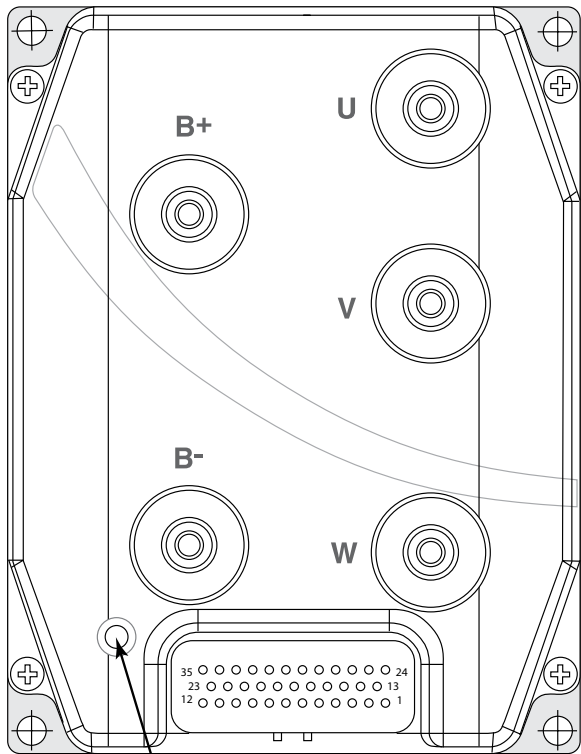

Status LED

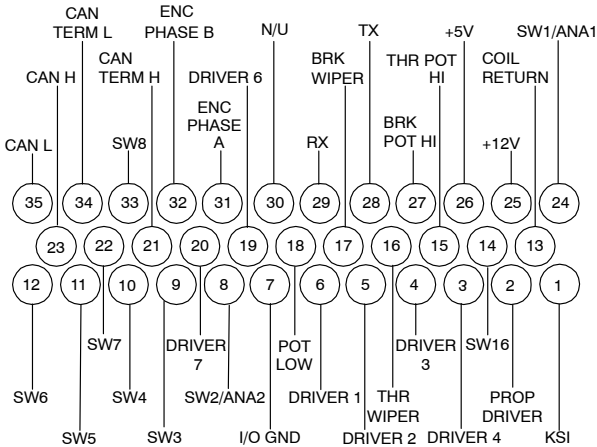

Types of LED Display

Display	Status
LED off	Controller is not powered on, has a dead battery, or is severely damaged.
Yellow LED flashing	Controller is operating normally.
Yellow LED on solid	Controller is in Flash program mode.
Red LED on solid	Watchdog failure. Cycle KSI to restart.
Red LED and yellow LED flashing alternately	Controller has detected a fault. 2-digit code* flashed by yellow LED identifies the specific fault; one or two flashes by red LED indicate whether first or second code digit will follow.

*The red LED flashes once to indicate that the first digit of the code will follow; the yellow LED then flashes the appropriate number of times for the first digit. The red LED flashes twice to indicate that the second digit of the code will follow; the yellow LED flashes the appropriate number of times for the second digit.

Example: Battery Undervoltage (Code 23)



TROUBLESHOOTING

Curtis 1232 Controller Diagnostic Codes, continued

TROUBLESHOOTING CHART			
CODE	FAULT CONDITION EFFECT OF FAULT	POSSIBLE CAUSE	SET/CLEAR CONDITIONS
12	Controller Overcurrent <i>ShutdownMotor;</i> <i>ShutdownMainContactor;</i> <i>ShutdownEMBrake;</i> <i>ShutdownThrottle;</i> <i>FullBrake;</i> <i>ShutdownPump.</i>	<ol style="list-style-type: none"> External short of phase U, V, or W motor connections. Motor parameters are mis-tuned. Controller defective. 	<p><i>Set:</i> Phase current exceeded the current measurement limit.</p> <p><i>Clear:</i> Cycle KSI.</p>
13	Current Sensor Fault <i>ShutdownMotor;</i> <i>ShutdownMainContactor;</i> <i>ShutdownEMBrake;</i> <i>ShutdownThrottle;</i> <i>FullBrake;</i> <i>ShutdownPump.</i>	<ol style="list-style-type: none"> Leakage to vehicle frame from phase U, V, or W (short in motor stator). Controller defective. 	<p><i>Set:</i> Controller current sensors have invalid offset reading.</p> <p><i>Clear:</i> Cycle KSI.</p>
14	Precharge Failed <i>ShutdownMotor;</i> <i>ShutdownMainContactor;</i> <i>ShutdownEMBrake;</i> <i>ShutdownThrottle;</i> <i>FullBrake;</i> <i>ShutdownPump.</i>	<ol style="list-style-type: none"> External load on capacitor bank (B+ connection terminal) that prevents the capacitor bank from charging. See Monitor menu » Battery: Capacitor Voltage. 	<p><i>Set:</i> Precharge failed to charge the capacitor bank to the KSI voltage.</p> <p><i>Clear:</i> Cycle interlock input or use VCL function.</p>
15	Controller Severe Undertemp <i>ShutdownMotor;</i> <i>ShutdownMainContactor;</i> <i>ShutdownEMBrake;</i> <i>ShutdownThrottle;</i> <i>FullBrake;</i> <i>ShutdownPump.</i>	<ol style="list-style-type: none"> See Monitor menu » Controller: Temperature. Controller is operating in an extreme environment. 	<p><i>Set:</i> Heatsink temperature below -40°C.</p> <p><i>Clear:</i> Bring heatsink temperature above -40°C, and cycle interlock or KSI.</p>
16	Controller Severe Overtemp <i>ShutdownMotor;</i> <i>ShutdownMainContactor;</i> <i>ShutdownEMBrake;</i> <i>ShutdownThrottle;</i> <i>FullBrake;</i> <i>ShutdownPump.</i>	<ol style="list-style-type: none"> See Monitor menu » Controller: Temperature. Controller is operating in an extreme environment. Excessive load on vehicle. Improper mounting of controller. 	<p><i>Set:</i> Heatsink temperature above +95°C.</p> <p><i>Clear:</i> Bring heatsink temperature below +95°C, and cycle interlock or KSI.</p>
17	Severe Undervoltage <i>Reduced drive torque.</i>	<ol style="list-style-type: none"> Battery Menu parameters are misadjusted. Non-controller system drain on battery. Battery resistance too high. Battery disconnected while driving. See Monitor menu » Battery: Capacitor Voltage. Blown B+ fuse or main contactor did not close. 	<p><i>Set:</i> Capacitor bank voltage dropped below the severe undervoltage limit with FET bridge enabled.</p> <p><i>Clear:</i> Bring capacitor voltage above severe undervoltage limit.</p>

PMC003

Terms:

KSI = Key Switch Interlock

FET = Field-Effect Transistor

Curtis 1232 Controller Diagnostic Codes, continued

TROUBLESHOOTING CHART, continued			
CODE	FAULT CONDITION <i>EFFECT OF FAULT</i>	POSSIBLE CAUSE	SET/CLEAR CONDITIONS
18	Severe Overvoltage <i>ShutdownMotor; ShutdownMainContactor; ShutdownEMBrake; ShutdownThrottle; FullBrake; ShutdownPump.</i>	<ol style="list-style-type: none"> 1. See Monitor menu » Battery: Capacitor Voltage. 2. Battery menu parameters are misadjusted. 3. Battery resistance too high for given regen current. 4. Battery disconnected while regen braking. 	<p><i>Set:</i> Capacitor bank voltage exceeded the Severe Overvoltage limit with FET bridge enabled.</p> <p><i>Clear:</i> Bring capacitor voltage below Severe Overvoltage limit, and then cycle KSI.</p>
22	Controller Overtemp Cutback <i>Reduced drive and brake torque.</i>	<ol style="list-style-type: none"> 1. See Monitor menu » Controller: Temperature. 2. Controller is performance-limited at this temperature. 3. Controller is operating in an extreme environment. 4. Excessive load on vehicle. 5. Improper mounting of controller. 	<p><i>Set:</i> Heatsink temperature exceeded 85°C.</p> <p><i>Clear:</i> Bring heatsink temperature below 85°C.</p>
23	Undervoltage Cutback <i>Reduced drive torque.</i>	<ol style="list-style-type: none"> 1. Normal operation. Fault shows that the batteries need recharging. Controller is performance limited at this voltage. 2. Battery parameters are misadjusted. 3. Non-controller system drain on battery. 4. Battery resistance too high. 5. Battery disconnected while driving. 6. See Monitor menu » Battery: Capacitor Voltage. 7. Blown B+ fuse or main contactor did not close. 	<p><i>Set:</i> Capacitor bank voltage dropped below the Undervoltage limit with the FET bridge enabled.</p> <p><i>Clear:</i> Bring capacitor voltage above the Undervoltage limit.</p>
24	Overvoltage Cutback <i>Reduced brake torque.</i>	<ol style="list-style-type: none"> 1. Normal operation. Fault shows that regen braking currents elevated the battery voltage during regen braking. Controller is performance limited at this voltage. 2. Battery parameters are misadjusted. 3. Battery resistance too high for given regen current. 4. Battery disconnected while regen braking. 5. See Monitor menu » Battery: Capacitor Voltage. 	<p><i>Set:</i> Capacitor bank voltage exceeded the Overvoltage limit with the FET bridge enabled.</p> <p><i>Clear:</i> Bring capacitor voltage below the Overvoltage limit.</p>
25	+5V Supply Failure <i>None, unless a fault action is programmed in VCL.</i>	<ol style="list-style-type: none"> 1. External load impedance on the +5V supply (pin 26) is too low. 2. See Monitor menu » outputs: 5 Volts and Ext Supply Current. 	<p><i>Set:</i> +5V supply (pin 26) outside the +5V +/-10% range.</p> <p><i>Clear:</i> Bring voltage within range.</p>
26	Digital Out 6 Overcurrent <i>Digital Output 6 driver will not turn on.</i>	<ol style="list-style-type: none"> 1. External load impedance on Digital Output 6 driver (pin 19) is too low. 	<p><i>Set:</i> Digital Output 6 (pin 19) current exceeded 15 mA.</p> <p><i>Clear:</i> Remedy the overcurrent cause and use the VCL function <i>Set_DigOut()</i> to turn the driver on again.</p>

VC004

Terms:
KSI = Key Switch Interlock
FET = Field-Effect Transistor

TROUBLESHOOTING

Curtis 1232 Controller Diagnostic Codes, continued

TROUBLESHOOTING CHART, continued			
CODE	FAULT CONDITION EFFECT OF FAULT	POSSIBLE CAUSE	SET/CLEAR CONDITIONS
27	Digital Out 7 Overcurrent <i>Digital Output 7 driver will not turn on.</i>	1. External load impedance on Digital Output 7 driver (pin 20) is too low.	<i>Set:</i> Digital Output 7 (pin 20) current exceeded 15 mA. <i>Clear:</i> Remedy the overcurrent cause and use the VCL function Set_DigOut() to turn the driver on again.
28	Motor Temp Hot Cutback <i>Reduced drive torque.</i>	1. Motor temperature is at or above the programmed Temperature Hot setting, and the requested current is being cut back. 2. Motor Temperature Control Menu parameters are mis-tuned. 3. See Monitor menu » Motor: Temperature and » Inputs: Analog2. 4. If the application doesn't use a motor thermistor, Temp Compensation and Temp Cutback should be programmed Off.	<i>Set:</i> Motor temperature is at or above the Temperature Hot parameter setting. <i>Clear:</i> Bring the motor temperature within range.
29	Motor Temp Sensor Fault <i>MaxSpeed reduced (LOS, Limited Operating Strategy), and motor temperature cutback disabled.</i>	1. Motor thermistor is not connected properly. 2. If the application does not use a thermistor, Temp Compensation and Temp Cutback should be programmed Off. 3. See Monitor menu » Motor: Temperature and » Inputs: Analog2.	<i>Set:</i> Motor thermistor input (pin 8) is at the voltage rail (0 or 10V). <i>Clear:</i> Bring the motor thermistor input voltage within range.
31	Coil1 Driver Open/Short <i>ShutdownDriver1.</i>	1. Open or short on driver load. 2. Dirty connector pins. 3. Bad crimps or faulty wiring.	<i>Set:</i> Driver 1 (pin 6) is either open or shorted. <i>Clear:</i> Correct open or short, and cycle driver.
32	EMBrake Open/Short <i>ShutdownEMBrake; ShutdownThrottle; FullBrake.</i>	1. Open or short on driver load. 2. Dirty connector pins. 3. Bad crimps or faulty wiring.	<i>Set:</i> Electromagnetic brake driver (pin 5) is either open or shorted. <i>Clear:</i> Correct open or short, and cycle driver.
33	Coil3 Driver Open/Short <i>ShutdownDriver3.</i>	1. Open or short on driver load. 2. Dirty connector pins. 3. Bad crimps or faulty wiring.	<i>Set:</i> Driver 3 (pin 4) is either open or shorted. <i>Clear:</i> Correct open or short, and cycle driver.
34	Coil4 Driver Open/Short <i>ShutdownDriver4.</i>	1. Open or short on driver load. 2. Dirty connector pins. 3. Bad crimps or faulty wiring.	<i>Set:</i> Driver 4 (pin3) is either open or shorted. <i>Clear:</i> Correct open or short, and cycle driver.

Terms:

KSI = Key Switch Interlock

FET = Field-Effect Transistor

VCL = Vehicle Control Language

Curtis 1232 Controller Diagnostic Codes, continued

TROUBLESHOOTING CHART, continued			
CODE	FAULT CONDITION <i>EFFECT OF FAULT</i>	POSSIBLE CAUSE	SET/CLEAR CONDITIONS
35	PD Open/Short <i>ShutdownPD.</i>	<ol style="list-style-type: none"> 1. Open or short on driver load. 2. Dirty connector pins. 3. Bad crimps or faulty wiring. 	<p><i>Set:</i> Proportional driver (pin 2) is either open or shorted.</p> <p><i>Clear:</i> Correct open or short, and cycle driver.</p>
36	Encoder Fault <i>ShutdownEMBrake.</i>	<ol style="list-style-type: none"> 1. Motor encoder failure. 2. Bad crimps or faulty wiring. 3. See Monitor menu » Motor: Motor RPM. 	<p><i>Set:</i> Motor encoder phase failure detected.</p> <p><i>Clear:</i> Cycle KSI.</p>
37	Motor Open <i>ShutdownMotor;</i> <i>ShutdownMainContactor;</i> <i>ShutdownEMBrake;</i> <i>ShutdownThrottle;</i> <i>FullBrake;</i> <i>ShutdownPump.</i>	<ol style="list-style-type: none"> 1. Motor phase is open. 2. Bad crimps or faulty wiring. 	<p><i>Set:</i> Motor phase U, V, or W detected open.</p> <p><i>Clear:</i> Cycle KSI.</p>
38	Main Contactor Welded <i>ShutdownMotor;</i> <i>ShutdownMainContactor;</i> <i>ShutdownEMBrake;</i> <i>ShutdownThrottle;</i> <i>FullBrake;</i> <i>ShutdownPump.</i>	<ol style="list-style-type: none"> 1. Main contactor tips are welded closed. 2. Motor phase U or V is disconnected or open. 3. An alternate voltage path (such as an external precharge resistor) is providing a current to the capacitor bank (B+ connection terminal). 	<p><i>Set:</i> Just prior to the main contactor closing, the capacitor bank voltage (B+ connection terminal) was loaded for a short time and the voltage did not discharge.</p> <p><i>Clear:</i> Cycle KSI</p>
39	Main Contactor Did Not Close <i>ShutdownMotor;</i> <i>ShutdownMainContactor;</i> <i>ShutdownEMBrake;</i> <i>ShutdownThrottle;</i> <i>FullBrake;</i> <i>ShutdownPump.</i>	<ol style="list-style-type: none"> 1. Main contactor did not close. 2. Main contactor tips are oxidized, burned, or not making good contact. 3. External load on capacitor bank (B+ connection terminal) that prevents capacitor bank from charging. 4. Blown B+ fuse. 	<p><i>Set:</i> With the main contactor commanded closed, the capacitor bank voltage (B+ connection terminal) did not charge to B+.</p> <p><i>Clear:</i> Cycle KSI.</p>
41	Throttle Wiper High <i>ShutdownThrottle.</i>	<ol style="list-style-type: none"> 1. See Monitor menu » Inputs: Throttle Pot. 2. Throttle pot wiper voltage too high. 	<p><i>Set:</i> Throttle pot wiper (pin 16) voltage is higher than the high fault threshold (can be changed with the VCL function Setup_Pot_Faults())</p> <p><i>Clear:</i> Bring throttle pot wiper voltage below the fault threshold.</p>
42	Throttle Wiper Low <i>ShutdownThrottle.</i>	<ol style="list-style-type: none"> 1. See Monitor menu » Inputs: Throttle Pot. 2. Throttle pot wiper voltage too low. 	<p><i>Set:</i> Throttle pot wiper (pin 16) voltage is lower than the low fault threshold (can be changed with the VCL function Setup_Pot_Faults()).</p> <p><i>Clear:</i> Bring throttle pot wiper voltage above the fault threshold.</p>
43	Pot2 Wiper High <i>FullBrake.</i>	<ol style="list-style-type: none"> 1. See Monitor menu » Inputs: Pot2 Raw. 2. Pot2 wiper voltage too high. 	<p><i>Set:</i> Pot2 wiper (pin 17) voltage is higher than the high fault threshold (can be changed with the VCL function Setup_Pot_Faults()).</p> <p><i>Clear:</i> Bring Pot2 wiper voltage below the fault threshold.</p>

PMCO06

Terms:
 KSI = Key Switch Interlock
 FET = Field-Effect Transistor
 VCL = Vehicle Control Language

TROUBLESHOOTING

Curtis 1232 Controller Diagnostic Codes, continued

TROUBLESHOOTING CHART, continued			
CODE	FAULT CONDITION EFFECT OF FAULT	POSSIBLE CAUSE	SET/CLEAR CONDITIONS
44	Pot2 Wiper Low <i>FullBrake.</i>	<ol style="list-style-type: none"> 1. See Monitor menu » Inputs: Pot2 Raw. 2. Pot2 wiper voltage too low. 	<p><i>Set:</i> Pot2 wiper (pin 17) voltage is lower than the low fault threshold (can be changed with the VCL function Setup_Pot_Faults()).</p> <p><i>Clear:</i> Bring Pot2 wiper voltage above the fault threshold.</p>
45	Pot Low Overcurrent <i>ShutdownThrottle;</i> <i>FullBrake.</i>	<ol style="list-style-type: none"> 1. See Monitor menu » Outputs: Pot Low. 2. Combined pot resistance connected to pot low is too low. 	<p><i>Set:</i> Pot low (pin 18) current exceeds 10 mA.</p> <p><i>Clear:</i> Clear pot low overcurrent condition and cycle KSI.</p>
46	EEPROM Failure <i>ShutdownMotor;</i> <i>ShutdownMainContactor;</i> <i>ShutdownEMBrake;</i> <i>ShutdownThrottle;</i> <i>ShutdownInterlock;</i> <i>ShutdownDriver1;</i> <i>ShutdownDriver2;</i> <i>ShutdownDriver3;</i> <i>ShutdownDriver4;</i> <i>ShutdownPD;</i> <i>FullBrake;</i> <i>ShutdownPump.</i>	<ol style="list-style-type: none"> 1. Failure to write to EEPROM memory. This can be caused by EEPROM memory writes initiated by VCL, by the CAN bus, by adjusting parameters with the programmer, or by loading new software into the controller. 	<p><i>Set:</i> Controller operating system tried to write to EEPROM memory and failed.</p> <p><i>Clear:</i> Download the correct software (OS) and matching parameter default settings into the controller and cycle KSI.</p>
47	HPD/Sequencing Fault <i>ShutdownThrottle.</i>	<ol style="list-style-type: none"> 1. KSI, interlock, direction, and throttle inputs applied in incorrect sequence. 2. Faulty wiring, crimps, or switches at KSI, interlock, direction, or throttle inputs. 3. See Monitor menu » Inputs. 	<p><i>Set:</i> HPD (High Pedal Disable) or sequencing fault caused by incorrect sequence of KSI, interlock, direction and throttle inputs.</p> <p><i>Clear:</i> Reapply inputs in correct sequence.</p>
49	Parameter Change Fault <i>ShutdownMotor;</i> <i>ShutdownMainContactor;</i> <i>ShutdownEMBrake;</i> <i>ShutdownThrottle;</i> <i>FullBrake;</i> <i>ShutdownPump.</i>	<ol style="list-style-type: none"> 1. This is a safety fault caused by a change in certain parameter settings so that the vehicle will not operate until KSI is cycled. For example, if a user changes the Throttle Type this fault will appear and require cycling KSI before the vehicle can operate. 	<p><i>Set:</i> Adjustment of a parameter setting that requires cycling of KSI.</p> <p><i>Clear:</i> Cycle KSI</p>
51	Throttle SRO Fault <i>ShutdownThrottle/brake.</i> <i>Shutdown Motor.</i>	<ol style="list-style-type: none"> 1. Both throttle and brake inputs are active at the same time. 2. Faulty throttle and/or brake inputs. 	<p><i>Set:</i> Throttle and brake inputs applied at the same time.</p> <p><i>Clear:</i> Release throttle and brake pedals.</p>
52	HPD Fault <i>ShutdownThrottle/brake.</i> <i>Shutdown Motor.</i>	<ol style="list-style-type: none"> 1. Throttle is pressed before key switch is turned on. 2. Throttle is pressed before operator presses the seat switch. 	<p><i>Set:</i> Throttle is pressed before key switch is turned on or throttle is pressed before operator sits on the seat switch.</p> <p><i>Clear:</i> Release throttle and properly sequence key switch, seat switch and then throttle.</p>

Terms:

KSI = Key Switch Interlock

FET = Field-Effect Transistor

VCL = Vehicle Control Language

PMC007

Curtis 1232 Controller Diagnostic Codes, continued

TROUBLESHOOTING CHART, continued			
CODE	FAULT CONDITION <i>EFFECT OF FAULT</i>	POSSIBLE CAUSE	SET/CLEAR CONDITIONS
68	VCL Run Time Error <i>ShutdownMotor; ShutdownMainContactor; ShutdownEMBrake; ShutdownThrottle; ShutdownInterlock; ShutdownDriver1; ShutdownDriver2; ShutdownDriver3; ShutdownDriver4; ShutdownPD; FullBrake; ShutdownPump.</i>	<ol style="list-style-type: none"> 1. VCL code encountered a runtime VCL error. 2. See Monitor menu » Controller: VCL Error Module and VCL Error. This error can then be compared to the runtime VCL module ID and error code definitions found in the specific OS system information file. 	<p><i>Set:</i> Runtime VCL code error condition.</p> <p><i>Clear:</i> Edit VCL application software to fix this error condition; flash the new compiled software and matching parameter defaults; cycle KSI.</p>
69	External Supply Out of Range <i>None, unless a fault action is programmed in VCL.</i>	<ol style="list-style-type: none"> 1. External load on the 5V and 12V supplies draws either too much or too little current. 2. Fault Checking Menu parameters Ext Supply Max and Ext Supply Min are mis-tuned. 3. See Monitor menu » Outputs: Ext Supply Current. 	<p><i>Set:</i> The external supply current (combined current used by the 5V supply [pin 26] and 12V supply [pin 25]) is either greater than the lower current threshold. The two thresholds are defined by the External Supply Max and External Supply Min parameter settings.</p> <p><i>Clear:</i> Bring the external supply current within range.</p>
71	OS General <i>ShutdownMotor; ShutdownMainContactor; ShutdownEMBrake; ShutdownThrottle; ShutdownInterlock; ShutdownDriver1; ShutdownDriver2; ShutdownDriver3; ShutdownDriver4; ShutdownPD; FullBrake; ShutdownPump.</i>	<ol style="list-style-type: none"> 1. Internal controller fault. 	<p><i>Set:</i> Internal controller fault detected.</p> <p><i>Clear:</i> Cycle KSI</p>
72	PDO Timeout <i>ShutdownInterlock; CAN NMT State set to Pre-operational.</i>	<ol style="list-style-type: none"> 1. Time between CAN PDO messages received exceeded the PDO Timeout Period. 	<p><i>Set:</i> Time between CAN PDO messages received exceeded the PDO Timeout Period.</p> <p><i>Clear:</i> Cycle KSI.</p>
73	Stall Detected <i>ShutdownEMBrake.</i>	<ol style="list-style-type: none"> 1. Stalled motor. 2. Motor encoder failure. 3. Bad crimps or faulty wiring. 4. Problems with power supply for the motor encoder. 5. See Monitor menu » Motor: Motor RPM. 	<p><i>Set:</i> No motor encoder movement detected.</p> <p><i>Clear:</i> Either cycle KSI, or detect valid motor encoder signals while operating in LOS mode and return Throttle Command = 0 and Motor RPM= 0</p>

Terms:
 KSI = Key Switch Interlock
 FET = Field-Effect Transistor
 VCL = Vehicle Control Language
 CAN = Controller Area Network

PMC008

TROUBLESHOOTING

Curtis 1232 Controller Diagnostic Codes, continued

TROUBLESHOOTING CHART, continued			
CODE	FAULT CONDITION EFFECT OF FAULT	POSSIBLE CAUSE	SET/CLEAR CONDITIONS
87	Motor Characterization Fault <i>ShutdownMotor;</i> <i>ShutdownMainContactor;</i> <i>ShutdownEMBrake;</i> <i>ShutdownThrottle;</i> <i>FullBrake;</i> <i>ShutdownPump.</i>	1. Motor characterization failed during characterization process. See Monitor menu » Controller: Motor Characterization Error for cause: 0=none 1=encoder signal seen, but step size not determined; set Encoder Step Size manually 2=motor temp sensor fault 3=motor temp hot cutback fault 4= controller overtemp cutback fault 5=controller undertemp cutback fault 6=undervoltage cutback fault 7=severe overvoltage fault 8=encoder signal not seen, or one or both channels missing 9=motor parameters out of characterization range.	<i>Set:</i> Motor characterization failed during the motor characterization process. <i>Clear:</i> Correct fault; cycle KSI.
89	Motor Type Fault <i>ShutdownMotor;</i> <i>ShutdownMainContactor;</i> <i>ShutdownEMBrake;</i> <i>ShutdownThrottle;</i> <i>FullBrake;</i> <i>ShutdownPump.</i>	1. The Motor_Type parameter value is out of range.	<i>Set:</i> Motor_Type parameter is set to an illegal value. <i>Clear:</i> Set Motor_Type to correct value and cycle KSI.
91	VCL/OS Mismatch <i>ShutdownMotor;</i> <i>ShutdownMainContactor;</i> <i>ShutdownEMBrake;</i> <i>ShutdownThrottle;</i> <i>ShutdownInterlock;</i> <i>ShutdownDriver1;</i> <i>ShutdownDriver2;</i> <i>ShutdownDriver3;</i> <i>ShutdownDriver4;</i> <i>ShutdownPD;</i> <i>FullBrake;</i> <i>ShutdownPump.</i>	1. The VCL software in the controller does not match the OS software in the controller.	<i>Set:</i> VCL and OS software do not match; when KSI cycles, a check is made to verify that they match and a fault is issued when they do not. <i>Clear:</i> Download the correct VCL and OS software into the controller.
92	EM Brake Failed to Set <i>ShutdownEMBrake;</i> <i>ShutdownThrottle.</i>	1. Vehicle movement sensed after the EM Brake has been commanded to set. 2. EM Brake will not hold the motor from rotating.	<i>Set:</i> After the EM Brake was commanded to set and time has elapsed to allow the brake to fully engage, vehicle movement has been sensed. <i>Clear:</i> Activate the throttle.
93	Encoder LOS (Limited Operating Strategy) <i>Enter LOS control mode.</i>	1. Limited Operating Strategy (LOS) control mode has been activated, as a result of either an Encoder Fault (Code 36) or a Stall Detect Fault (Code 73). 2. Motor encoder failure. 3. Bad crimps or faulty wiring. 4. Vehicle is stalled.	<i>Set:</i> Encoder Fault (Code 36) or Stall Detect Fault (Code 73) was activated, and Brake or Interlock has been applied to activate LOS control mode, allowing limited motor control. <i>Clear:</i> Cycle KSI, or if LOS mode was activated by the Stall Fault, clear by ensuring encoder senses proper operation, Motor RPM = 0, and Throttle Command = 0.

PMC009

Terms:

KSI = Key Switch Interlock
FET = Field-Effect Transistor

VCL = Vehicle Control Language

Curtis 1232 Controller Diagnostic Codes, continued

TROUBLESHOOTING CHART, continued			
CODE	FAULT CONDITION <i>EFFECT OF FAULT</i>	POSSIBLE CAUSE	SET/CLEAR CONDITIONS
94	Emer Rev Timeout <i>ShutdownEMBrake;</i> <i>ShutdownThrottle.</i>	<ol style="list-style-type: none"> 1. Emergency Reverse was activated and concluded because the EMR Timeout timer has expired. 2. The emergency reverse input is stuck On. 	<p><i>Set:</i> Emergency Reverse was activated and ran until the EMR Timeout timer expired.</p> <p><i>Clear:</i> Turn the emergency reverse input Off.</p>
98	Illegal Model Number <i>ShutdownMotor;</i> <i>ShutdownMainContactor;</i> <i>ShutdownEMBrake;</i> <i>ShutdownThrottle;</i> <i>FullBrake;</i> <i>ShutdownPump.</i>	<ol style="list-style-type: none"> 1. Model_Number variable contains illegal value (not 1234, 1236, 1238, or 1298). 2. Software and hardware do not match. 3. Controller defective. 	<p><i>Set:</i> Illegal Model_Number variable; when KSI cycles a check is made to confirm a legal Model_Number, and a fault is issued if one is not found.</p> <p><i>Clear:</i> Download appropriate software for your controller model.</p>

Terms:

KSI = Key Switch Interlock
 FET = Field-Effect Transistor
 EMR = Emergency Reverse

TROUBLESHOOTING

INPUT DISPLAY MODE

Input Display Mode is an onboard diagnostic utility that displays controller input conditions. Input Display Mode displays LCD text messages for hard-wired switch, sensor, and touch panel button inputs.

1. Key switch Off. Press and hold the configuration mode button.

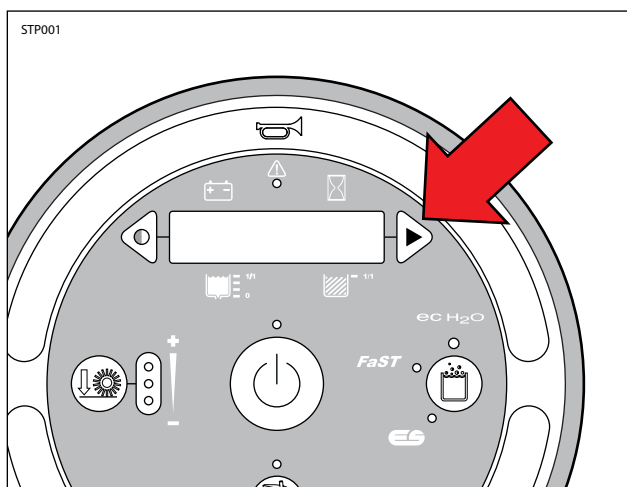

2. Key switch On. Release the configuration mode button when "CONFIG MODE" appears on the LCD.

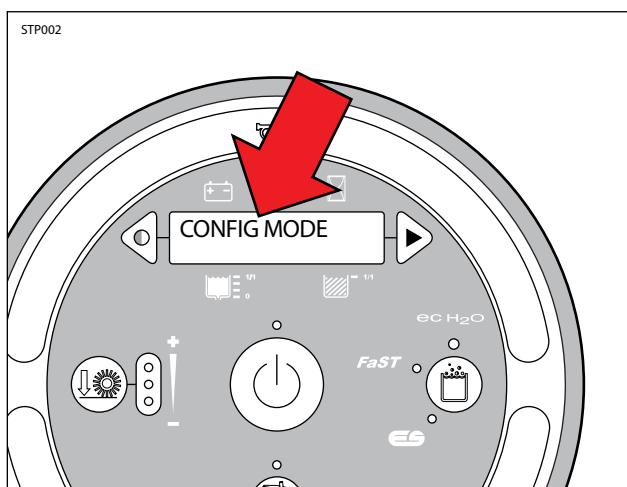

3. Press and release the configuration mode button to scroll through a list of utilities until "INPUT DISPLAY" appears on the LCD.

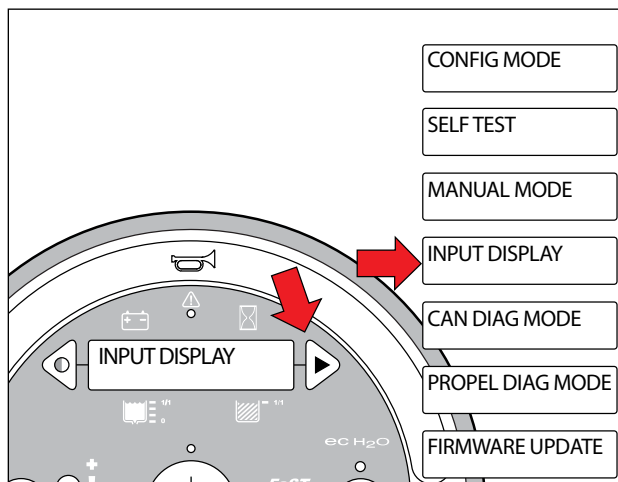

4. Press and release the brush pressure button to enter Input Display Mode. "I1:Solution Tank, Full Closed" will appear on the LCD.

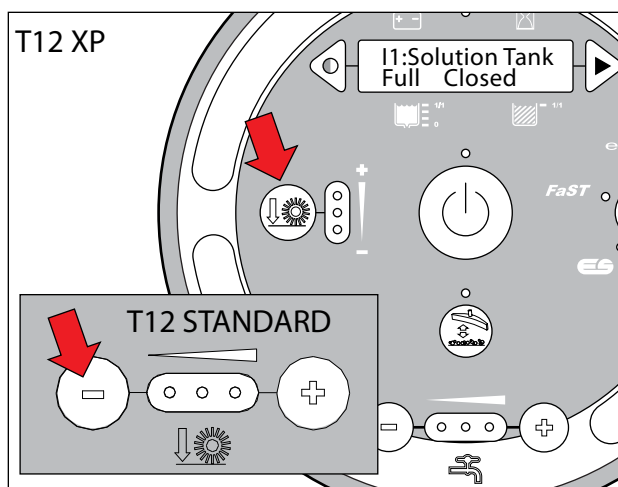

- 5. Press and release the configuration mode button to scroll through a list of hard-wired switch and sensor inputs.

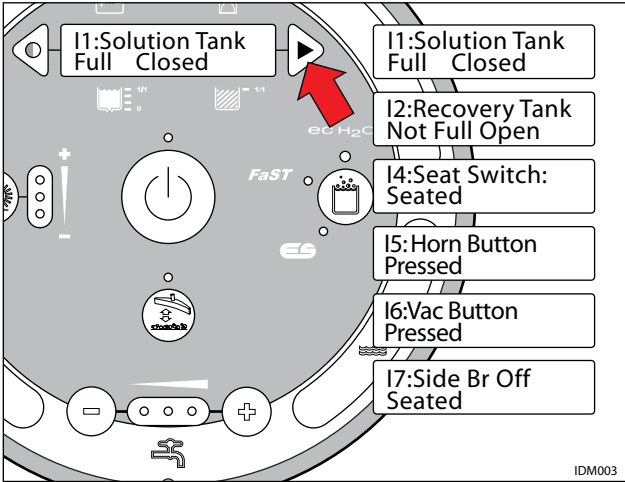

- 6. Press any other touch panel button to display a corresponding LCD text message. The message confirms that the control board received the input.

T12 XP

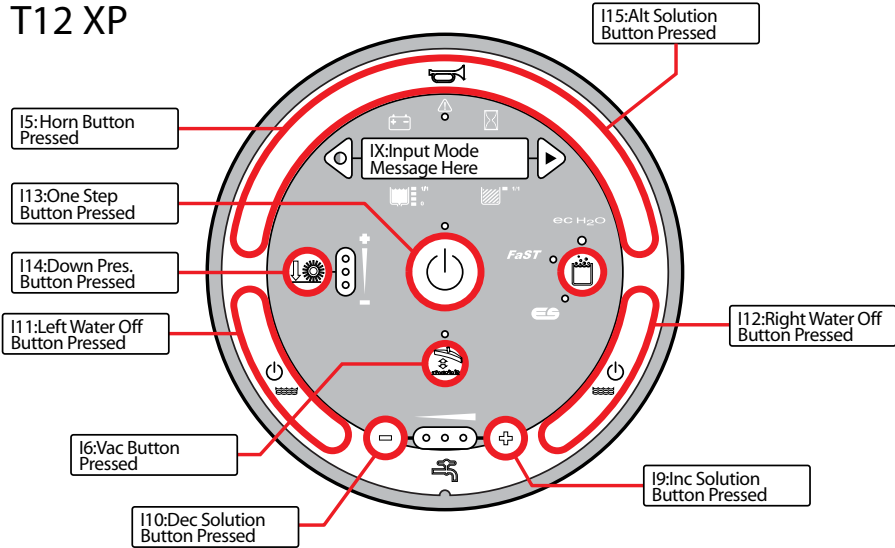

T12 STANDARD

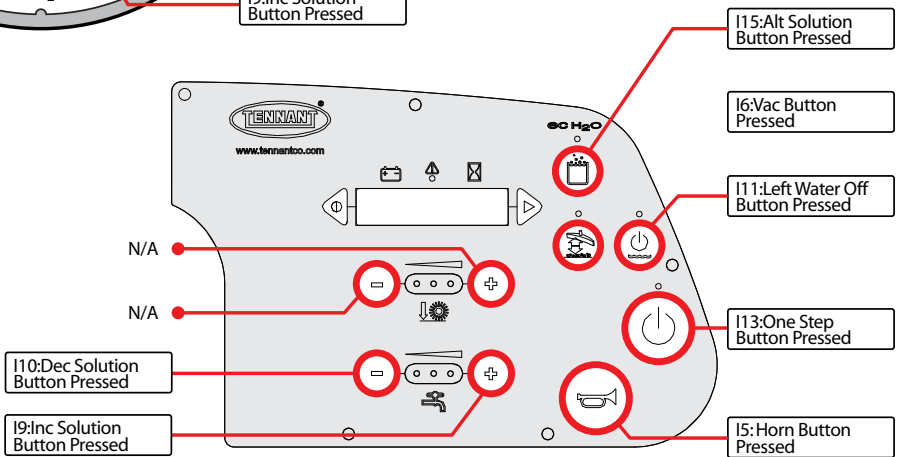

TROUBLESHOOTING

MANUAL MODE

Manual Mode is an onboard diagnostic utility that manually activates machine functions and displays output current in "XX.X Amps" format. This mode bypasses interlocking inputs and should be used for diagnostic purposes only.

1. Key switch Off. Press and hold the configuration mode button.

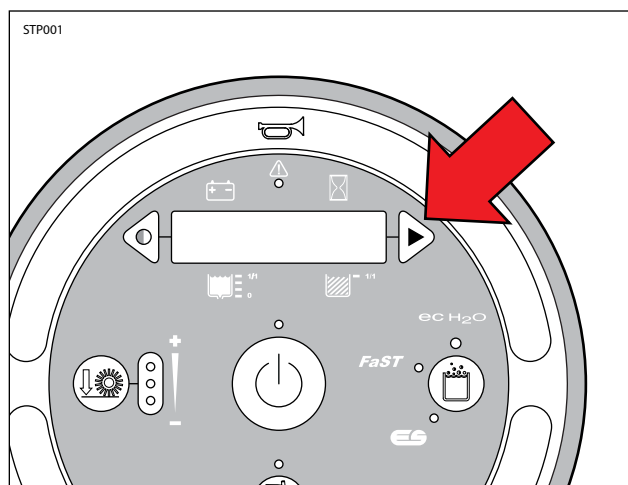

2. Key switch On. Release the configuration mode button when "CONFIG MODE" appears on the LCD.

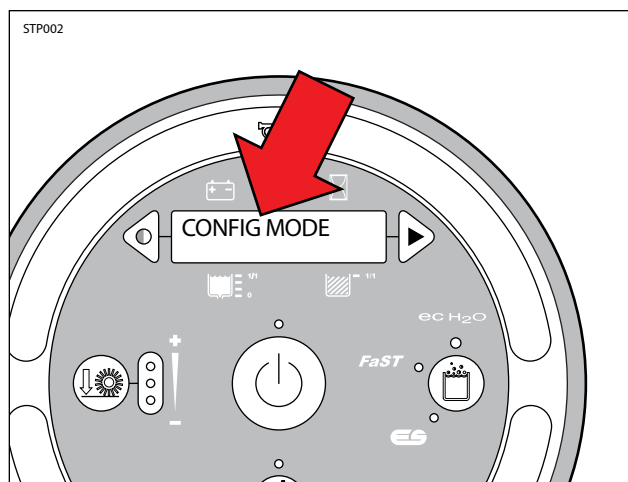

3. Press and release the configuration mode button to scroll through a list of utilities until "MANUAL MODE" appears on the LCD.

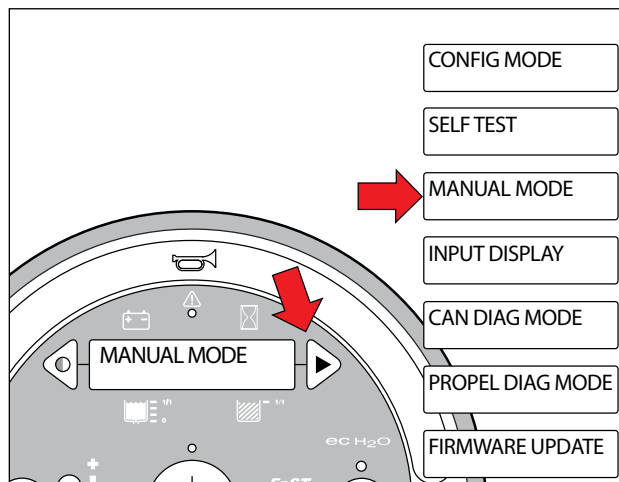

4. Press and release the brush pressure button to enter Manual Mode. "M01: Left Brush, 00% XX.XA" will appear on the LCD.

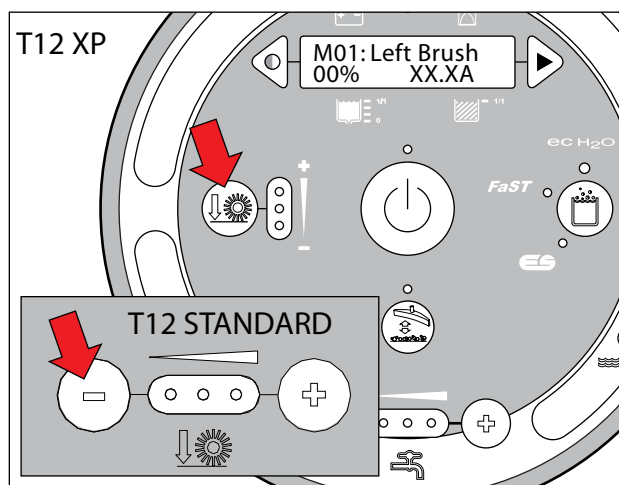

- Press and release the configuration mode button to scroll through a list of output functions. Press the brush down pressure button to activate the function displayed on the LCD (except functions in Step 6).

NOTE: "XX.XA" format indicates that the actual amperage value will vary. See the "Specifications" section of this manual for approximate amp draw values.

NOTE: "R" or "E" in the lower left corner of the LCD indicates Retracted or Extended actuator position.

NOTE: "XX%" refers to the duty cycle of the circuit load when activated.

NOTE: "OK" indicates that the displayed function is not open or shorted.

- The output functions listed below have specific operating instructions. Follow the instructions listed in the table below.

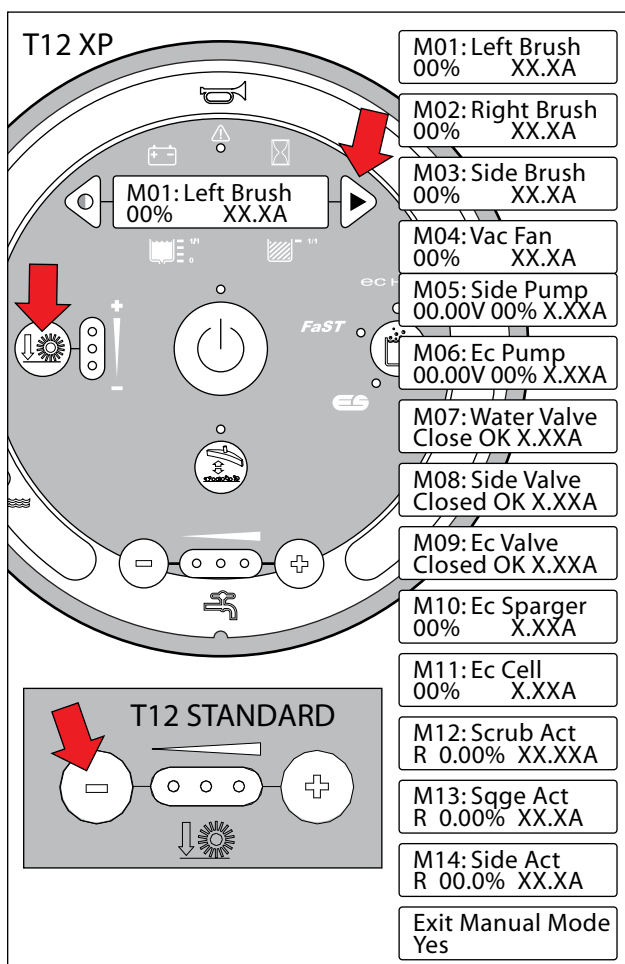

T12 Manual Mode Operation	
FUNCTION	OPERATION
Scrub Head Lift Actuator <i>(When M12... is displayed on LCD)</i>	Water Flow (-) = Completely Down Water Flow (+) = Completely Up LH Water Button = Momentary Down RH Water Button* = Momentary Up
Rear Squeegee Lift Actuator <i>(When M13... is displayed on LCD)</i>	Water Flow(-) Button = Down Water Flow(+) Button = Up
Side Brush Lift Actuator <i>(When M14...is displayed on LCD)</i>	Water Flow(-) Button = Down Water Flow(+) Button = Up
Side Valve <i>(When side pump M05... is On)</i>	Water Flow (+) and (-) Buttons Adjust Flow (Low, Med, High) No LEDs illuminated turns valve Off
Ec Valve <i>(When Ec Pump M06... is On)</i>	Water Flow (+) and (-) Buttons Adjust Flow (Low, Med, High) No LEDs illuminated turns valve Off
Water Valve-Main <i>When M01..., M02..., or M07... is displayed on the LCD)</i>	Water Flow (+) and (-) Buttons Adjust Flow (Low, Med, High) No LEDs illuminated turns main valve Off

* XP models only. Standard models have a single water button used for momentary downward actuator control. Use Water Flow (+) button to raise scrub head.

TROUBLESHOOTING

CAN DIAGNOSTIC MODE

CAN (Controller Area Network) Diagnostic Mode is an on-board diagnostic utility that displays connectivity status and a software revision date for each module.

1. Key switch Off. Press and hold the configuration mode button.

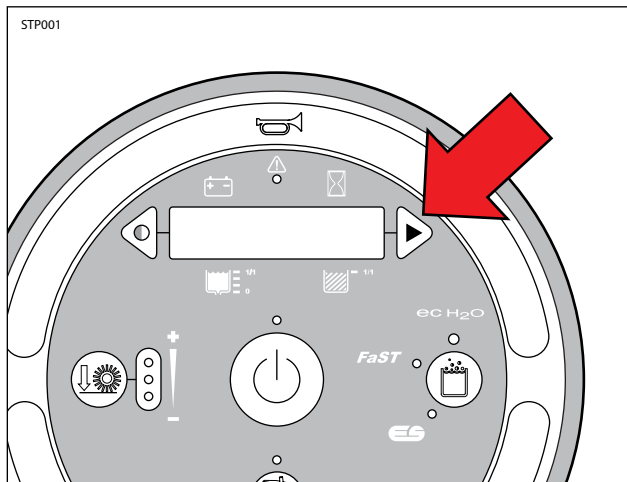

2. Key switch On. Release the configuration mode button when "CONFIG MODE" appears on the LCD.

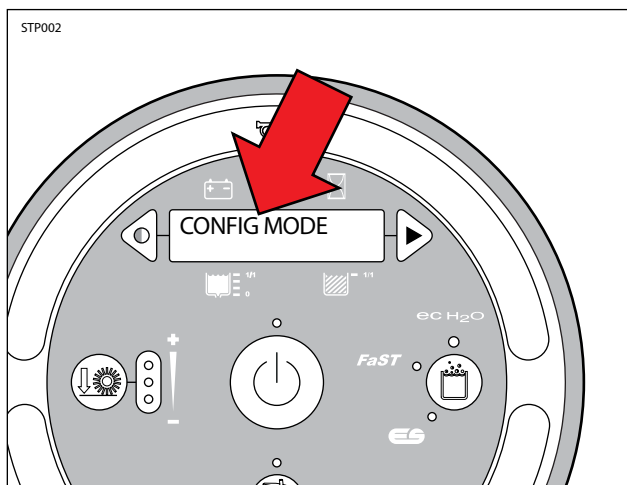

3. Press and release the configuration mode button to scroll through a list of utilities until "MANUAL MODE" appears on the LCD.

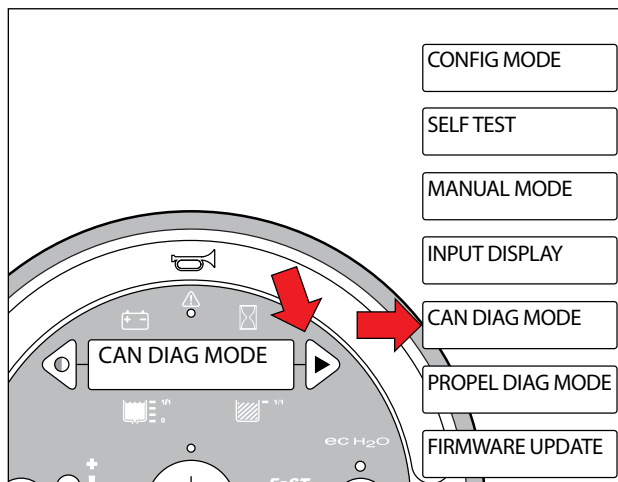

4. Press and release the brush pressure button to enter CAN Diagnostic Mode. "CD1: Scrub" will appear on the LCD.

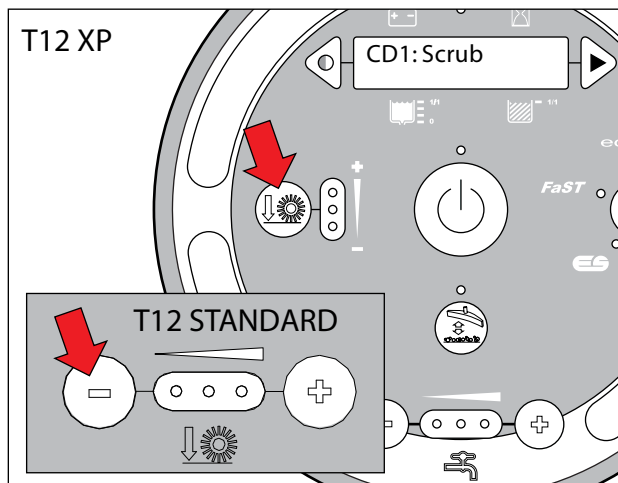

- Press and release the configuration mode button to scroll through a list of CAN modules. Press the brush down pressure button to select a specific module.

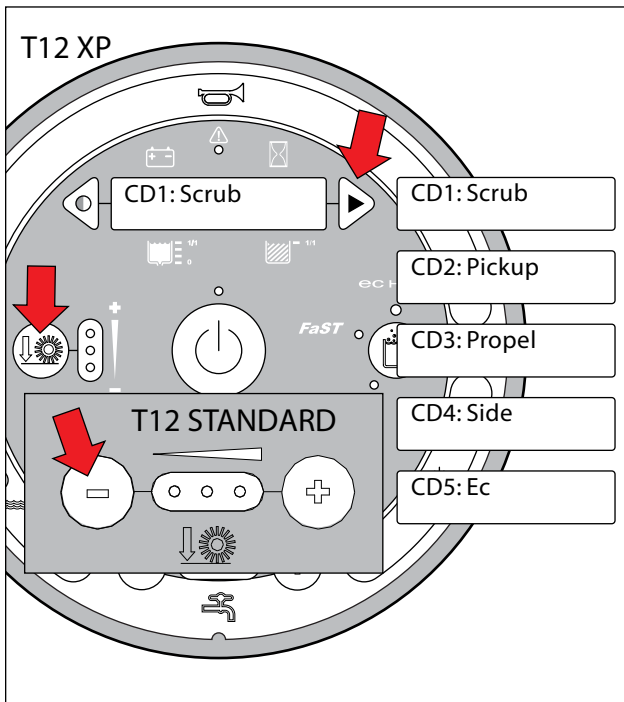

FIRMWARE UPDATE MODE

Firmware Update Mode is an onboard diagnostic utility that allows for software updates via an SD card. This mode should only be used by Tennant Service Personnel following an update kit IB (Instruction Bulletin).

- Press and release the configuration mode button to scroll through a list of CAN module information.

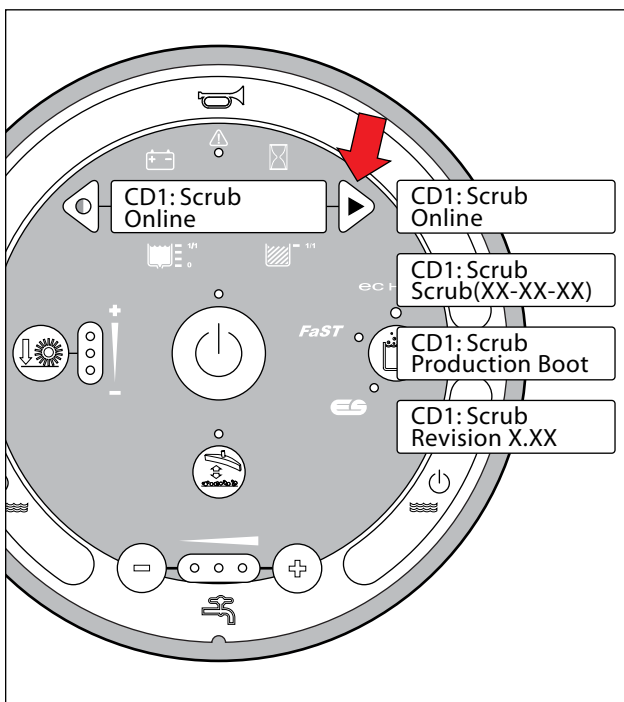

TROUBLESHOOTING

Battery Charger, Standard and Export

OPERATION

The standard battery charger utilizes a single-LED display. The LED flashes green during the charging cycle and changes to solid green when the charging cycle is complete.

This charger is programmable for standard lead-acid, heavy duty lead-acid batteries. The setting is displayed using the blink on/off method each time the battery charger is connected to an AC power supply and the charger is disconnected from the batteries.

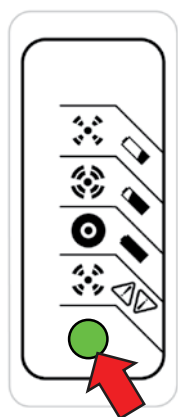

DQC001

	Green		Solid: Charge Complete
			Flashing: Charging
	Amber		Flashing: Reduced Power Mode. Low AC Voltage or Hi Charger Temp
	Red		Flashing: Charger Error See Faults Below

CONFIGURATION

DISPLAYING CURRENT CHARGER SETTING

1. Key Off. Disconnect battery charger from AC power supply and the batteries. Wait 30 seconds before proceeding to step 2 to allow for capacitor discharge.
2. Connect charger to AC supply and observe the LED display. It will blink on/off to indicate the current battery charger setting for 11 seconds.

ALGORITHM #	BATTERY TYPE
3	Lead-Acid, 240 Ah* (Trojan T105)
7	Lead-Acid, 360 Ah* (Trojan J305)
12	GEL, 240 Ah* (Exide DF06240)
28	GEL, 180 Ah* (Deka 8GGC2)
43	AGM, 300 Ah* (Discover EVL16A, EVGC6A)

* @ 20 hour rate

CHANGING CHARGER SETTING

1. Key Off. Disconnect battery charger from AC power supply and the batteries. Wait 30 seconds before proceeding to step 2 to allow for capacitor discharge.
2. Connect charger to AC supply and observe the LED display. It will blink on/off to indicate the current battery charger setting for 11 seconds.
3. Connect the battery charger to the batteries for 2 seconds and then disconnect from the batteries, during the 11 second window, to advance to the next highest setting.

NOTE: The 11 second window expands to 30 seconds after the first change has been made.

NOTE: There are 10 total algorithms. The advancement sequence increases each time and then loops back to #1.

4. Wait 45 seconds after a change has been made to save the new charger setting.

FAULTS

A flashing red LED indicates a charger error. Count the number of flashes separated by a long pause and then use the table below to identify a possible cause.

RED FLASHES	POSSIBLE CAUSE
1	Battery High Voltage
2	Battery Low Voltage
3	Charge timeout. Batteries failed to reach required voltage. Charger output was reduced due to high temperatures.
4	Check battery. Battery could not be trickle charged up to minimum voltage.
5	Over-Temperature: Charger shut down due to high internal temperature.
6	Charger internal fault. Disconnect for 15 seconds and reset charger.

Battery Charger, Onboard (Option)

OPERATION

The onboard battery charger utilizes a 4 character digital display, 3 control indicator LEDs and a scroll button. The red control indicator illuminates at the beginning of the charging cycle. The yellow control indicator illuminates when the final phase of the charging cycle begins and the green control indicator illuminates when the charging cycle is complete.

Each time the battery charger is connected to an AC power supply, the charger displays; "SPE," the software revision date, battery voltage, charging current, charging curve number, and finally the words "GEL" (Gel) or "Acd" (Lead-Acid) depending on how the charger is configured from the factory.

Pressing the scroll button during the charge cycle will change the display mode between; A (charging current), U (battery voltage), h (charging time), C (charging amp-hours), and E (energy used KWh).

CONFIGURATION, LEAD ACID/GEL

1. Key Off. Disconnect battery charger from AC power supply and the batteries.
2. Carefully remove the charger display cover decal to access the programmable dip switches.
3. Use the table below to set the dip switches for Lead-Acid or Gel batteries.

NOTE: The dip switches below are shown in the default 240AH Lead-Acid position.

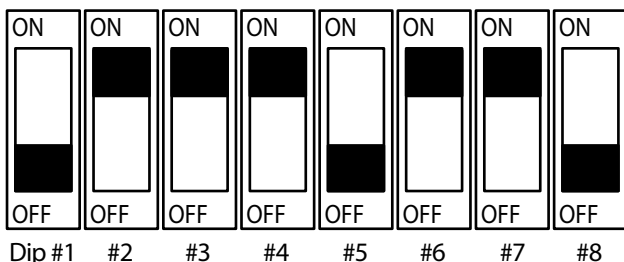

OBC005

TYPE	#1	#2	#3	#4	#5	#6	#7	#8
GEL	ON	ON	ON	ON	OFF	ON	ON	OFF
240 Ah*	OFF	ON	ON	ON	OFF	ON	ON	OFF
360 Ah*	OFF	OFF	ON	ON	OFF	ON	ON	OFF

* @ 20 hour rate

FAULTS

Fault messages automatically display when a fault exists. Use the table below to identify possible causes.

FAULT	POSSIBLE CAUSE
"bat"	Poor or no battery connection or reversed polarity
"E01"	Maximum battery voltage exceeded.
"E02"	Maximum battery temperature exceeded.
"E03"	Maximum charging time exceeded.
"Sct"	The total safety timer has interrupted charging.
"Srt"	Internal charger short circuit possible.

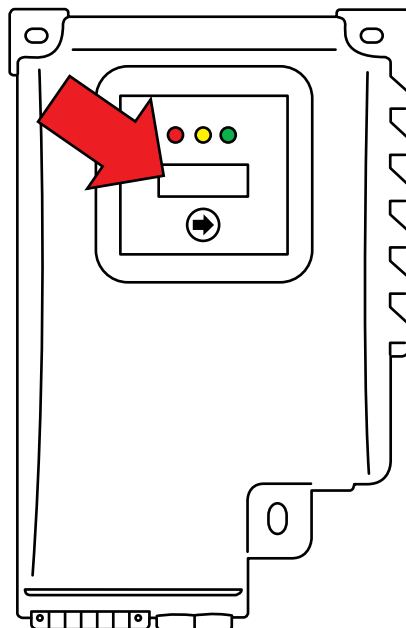

OBC003

TROUBLESHOOTING

Back-Up Alarm/Light ON

Note: Key Switch ON

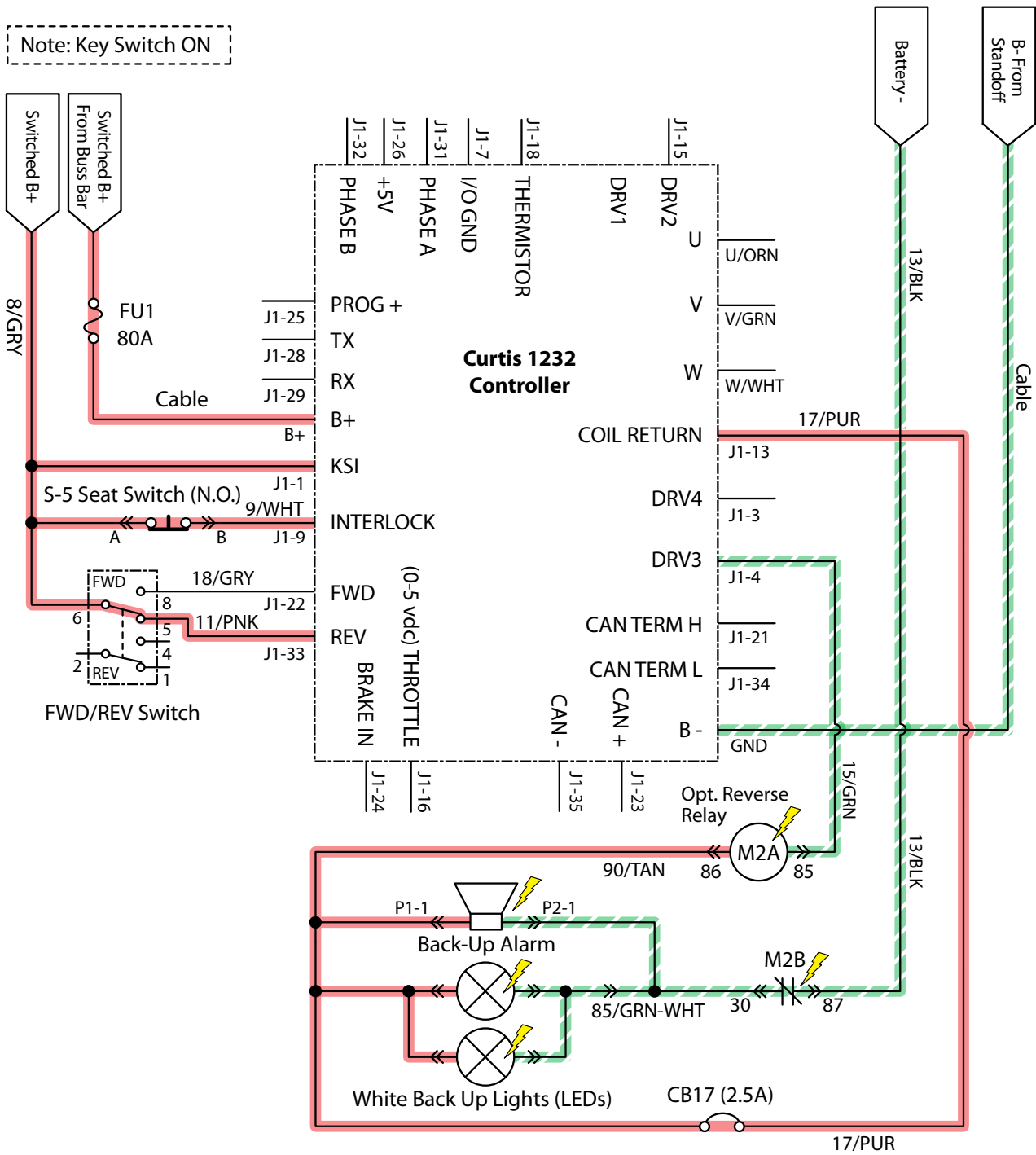

- Battery Positive +
- Battery Negative -

Operational Matrix:

	Enabled	Disabled
Back-Up Alarm/Lights	<ul style="list-style-type: none"> • Rev Switch Input • Rev Throttle Command 	<ul style="list-style-type: none"> • Fwd Switch Input • Neutral - Ready State • Curtis 1232 Fault

PMCO11

Back-Up Alarm/Light Failed to Turn ON

STEP	ACTION	VALUE(S)	YES	NO
1	<ul style="list-style-type: none"> • Key On • Enable back-up alarm/lights • Is there a pertinent LCD warning or fault message displayed? 		See "LCD Warnings" or "LCD Faults" Sections	Go to Step #2
2	<ul style="list-style-type: none"> • Key On • Enable back-up alarm/lights • See "Curtis 1232 Controller Diagnostics" • Is there a pertinent Curtis 12342 fault displayed? 		Correct Fault Condition	Go to Step #3
3	<ul style="list-style-type: none"> • Key Off • See "Propel Diagnostic Mode" section of this manual • Check the "P4:Direction Fwd/Rev" input from the directional switch • Check the "P2:Throttle" (0-5 vdc) input from the directional pedal • Are the P2 and P4 inputs operating properly? 		Go to Step # 4	Correct Faulty Input Condition
4	<ul style="list-style-type: none"> • Key Off • Remove M2 relay from connector (see component locator) • Connect an Ohmmeter between relay terminals 30 and 87 (should test open or "O.L.") • Apply battery voltage to relay terminals 86 (+) and 85 (-) using fuse-protected jumper leads • Does the relay "click" and do the N.O. (normally open) terminals 30 and 87 close? 		Go to Step #5	Replace Relay
5	<ul style="list-style-type: none"> • Key Off • Disconnect back-up alarm/light from main harness • Apply battery voltage to back-up alarm/light using fuse-protected jumper leads • Does the back-up alarm/light turn On? 		Go to Step #6	Replace Back-Up Alarm/Light
6	<ul style="list-style-type: none"> • Key On • Reconnect back-up alarm/light to main harness • Enable back-up alarm/light • Backprobe using a voltmeter between 15/GRN and 17/PUR at the Curtis 1232 controller connection • Is there battery voltage applied? 		Repair or Replace Wire Harness	Replace Curtis 1232 Controller

Terms:

LCD = Liquid Crystal Display

Backprobe = To insert voltmeter probe(s) into the back of a connector to contact a terminal(s) while the circuit operates or should be operating.

VDC = DC Voltage

TROUBLESHOOTING

Onboard Battery Charging ON

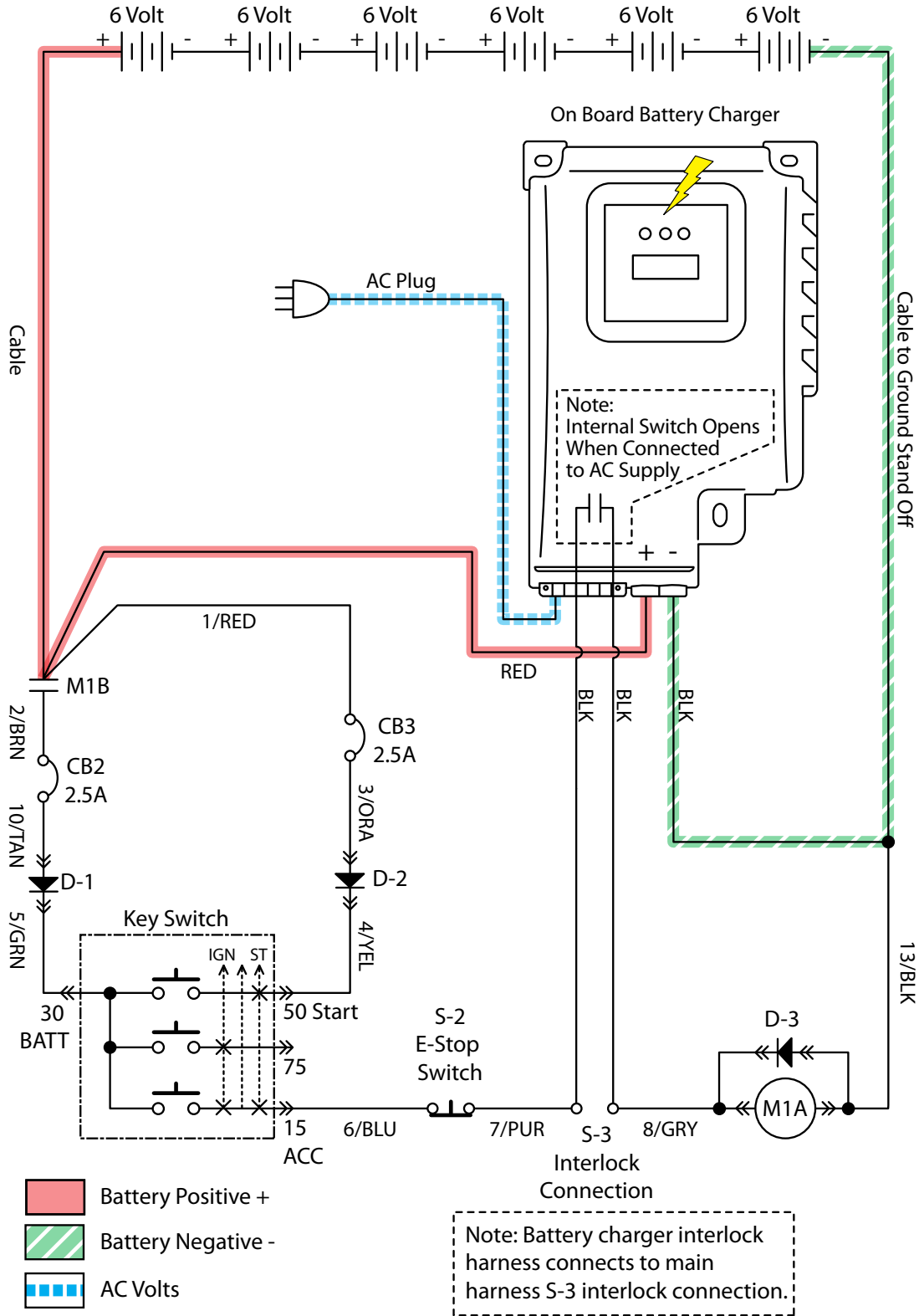

OBC001

Batteries Failed to Charge

STEP	ACTION	VALUE(S)	YES	NO
1	<ul style="list-style-type: none"> Key Off Is there a pertinent fault displayed on the onboard charger (bat, E01, E02, E03, SCt, or Srt)? 		See "Onboard Battery Charger Faults" Section of This Manual	Go to Step #2
2	<ul style="list-style-type: none"> Key Off Check AC power supply Is the rated AC supply voltage present? 		Go to Step #3	Check AC Supply Circuit Protection
3	<ul style="list-style-type: none"> Key Off Disconnect batteries Unplug charger from AC supply Check fuse located on bottom side of charger Is the fuse blown? 		Replace Fuse and Test Charger Operation	Go to Step #4
4	<ul style="list-style-type: none"> Key Off Inspect battery and charger cables for damage, corrosion, contamination or terminal problems Do any of the above conditions exist? 		Repair or Replace Battery and/or Charger Cables	Go to Step #5
5	<ul style="list-style-type: none"> Skip this step for sealed, AGM, or gel batteries Key Off Disconnect batteries Check water level of all battery cells Are the lead plates submerged? 		Go to Step #6	Add Distilled Water Until Lead Plates are Covered.
6	<ul style="list-style-type: none"> Key Off Load test all batteries (AGM, Gel, Lead-Acid) -or- Test specific gravity of each cell using a hydrometer or refractometer (Lead-Acid) Do the batteries pass a load test or are all battery cells within 0.050 (50 points) specific gravity of each other? 		Replace Battery Charger	Replace Battery or Batteries

Terms:

AC = Alternating Current

AGM = Absorbed Glass Mat

Specific Gravity = Relative density of a substance compared to water (1.000 specific gravity)

TROUBLESHOOTING

Off Board Battery Charging ON

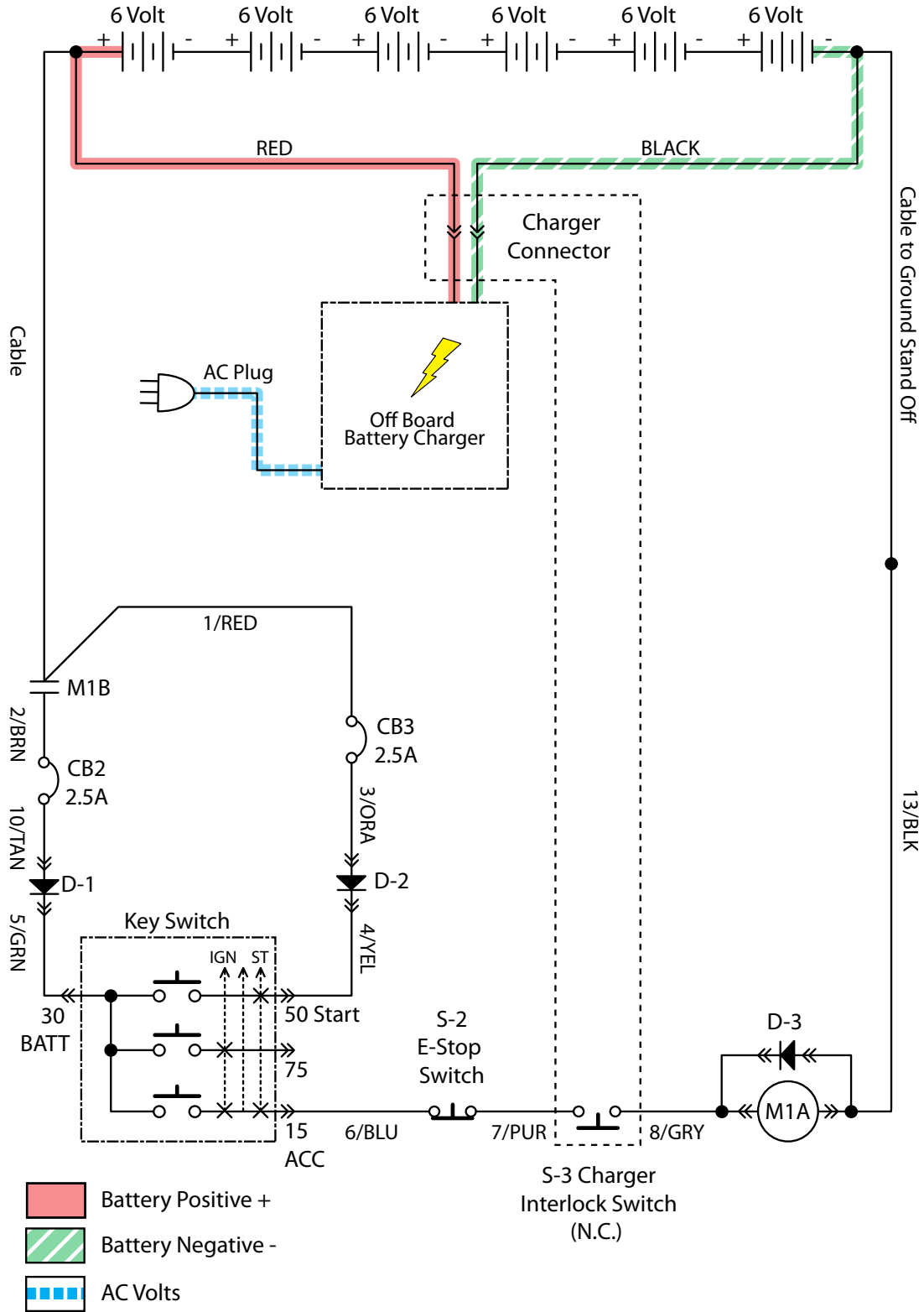

OBC002

Batteries Failed to Charge

STEP	ACTION	VALUE(S)	YES	NO
1	<ul style="list-style-type: none"> • Key Off • Check AC power supply • Is the rated AC supply voltage present? 		Go to Step #2	Check AC Supply Circuit Protection
2	<ul style="list-style-type: none"> • Key Off • Disconnect batteries • Unplug charger from AC supply • Check charger fuse or circuit breaker (if equipped) • Is a fuse blown or circuit breaker tripped? 		Replace Fuse or Reset Circuit Breaker and Test Charger Operation	Go to Step #3
3	<ul style="list-style-type: none"> • Key Off • Inspect battery and charger cables for damage, corrosion, contamination or terminal problems • Do any of the above conditions exist? 		Repair or Replace Battery and/or Charger Cables	Go to Step #4
4	<ul style="list-style-type: none"> • Skip this step for sealed, AGM, or gel batteries • Key Off • Disconnect batteries • Check water level of all battery cells • Are the lead plates submerged? 		Go to Step #5	Add Distilled Water Until Lead Plates are Covered.
5	<ul style="list-style-type: none"> • Key Off • Load test all batteries (AGM, Gel, Lead-Acid) • -or- • Test specific gravity of each cell using a hydrometer or refractometer ((Lead-Acid) • Do the batteries pass a load test or are all battery cells within 0.050 (50 points) specific gravity of each other? 		Replace Battery Charger	Replace Battery or Batteries

Terms:

AC = Alternating Current

AGM = Absorbed Glass Mat

Specific Gravity = Relative density of a substance compared to water (water = 1.000 specific gravity)

Parking Brake, Electromagnetic (Released)

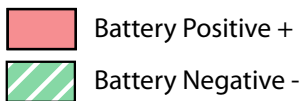
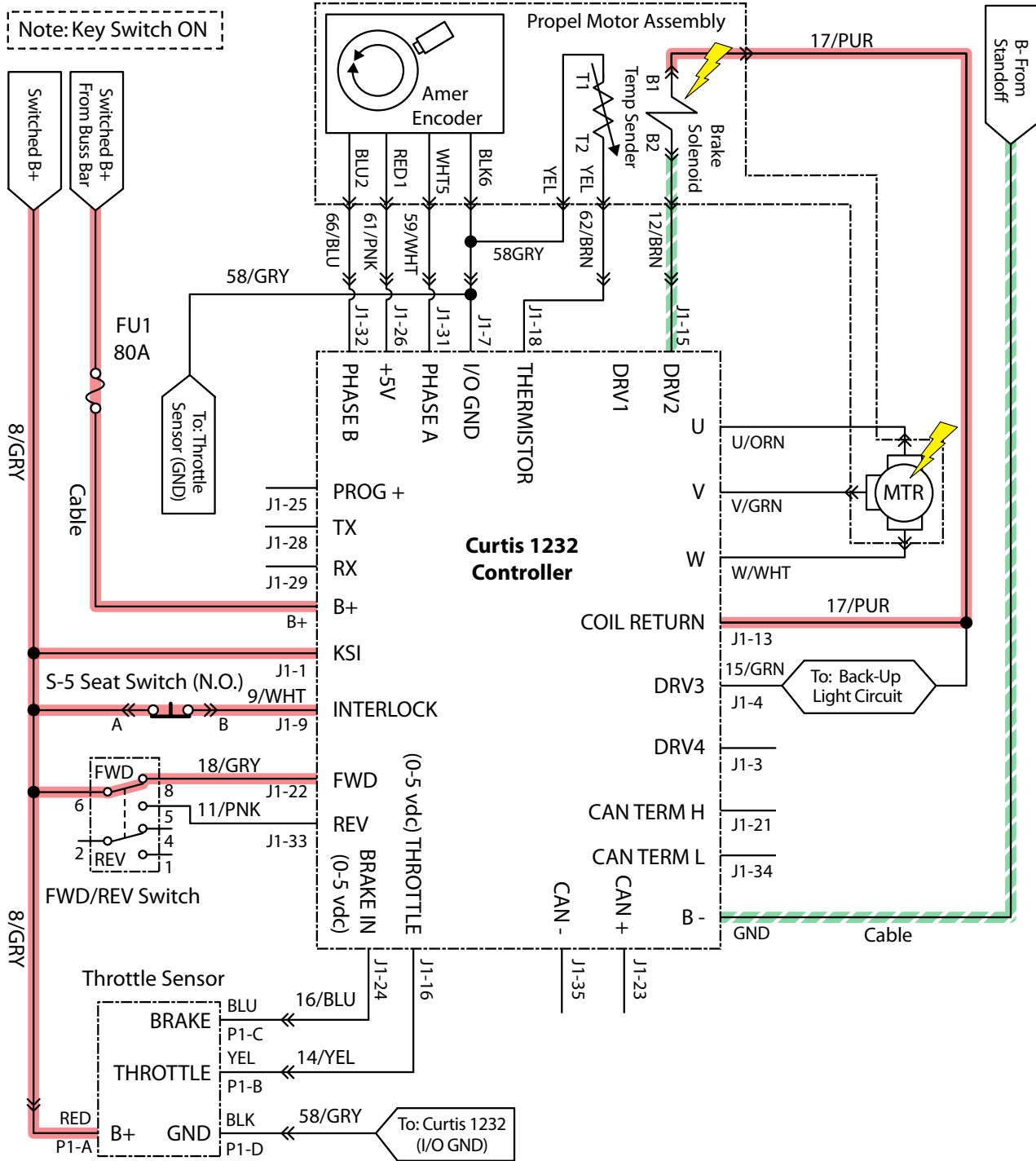

Operational Matrix:

	Enabled (Applied)	Disabled (Released)
Electro-Magnetic Brake	• Key Off	• Key ON
	• E-Stop Switch Open (Up)	• E-Stop Switch Closed (Down)
	• Neutral (1-2 Second Delay)	• Throttle Command
	• Seat Switch Open	• Seat Switch Closed
	• Curtis 1232 Fault	

PMC012

Parking Brake Failed to Release/Apply

STEP	ACTION	VALUE(S)	YES	NO
1	<ul style="list-style-type: none"> • Key On • Is there a pertinent LCD warning or fault message displayed? 		See "LCD Warnings" or "LCD Faults" Sections	Go to Step #2
2	<ul style="list-style-type: none"> • Key On • See "Curtis 1232 Controller Diagnostics" section • Is there a pertinent Curtis 1232 fault displayed? 		Correct Fault Condition	Go to Step #3
3	<ul style="list-style-type: none"> • Key Off • See "Propel Diagnostic Mode" • Is P1:Curtis Online? • Does P2:Throttle input voltage (0-5 vdc) change proportionally with throttle pedal movement? • Does P3:Brake pedal input turn On/Off with brake pedal activation? • Does P4:Direction input correspond with Fwd/Rev rocker switch position? • Does P5:Speed input from drive assembly encoder (speed, direction, position sensor) read "0000.0 Mph?" • Does P8:Propel motor current read "0000.0 Amps?" • Is the answer "Yes" to all of the above? 		Go to Step #4	Correct Faulty Input Condition
4	<ul style="list-style-type: none"> • Key Off • See TESTING PARKING BRAKE, ELECTROMAGNETIC in the SERVICE section of this manual • Does the brake pass the testing? 	See TESTING PARKING BRAKE, ELECTROMAGNETIC	Go to Step #5	Repair or Replace Parking Brake Assembly
5	<ul style="list-style-type: none"> • Reconnect parking brake assembly to propel harness • Key On • Disable(Release) brake • Test voltage applied to the parking brake as shown on the electrical schematic • Are the electrical circuits operating as shown on the electrical schematic? 		Go Back to Step #1	Identify Voltage Drop Location and Repair or Replace Necessary Components

Terms:

LCD = Liquid Crystal Display

TROUBLESHOOTING

Lighting ON

Note: Key Switch ON

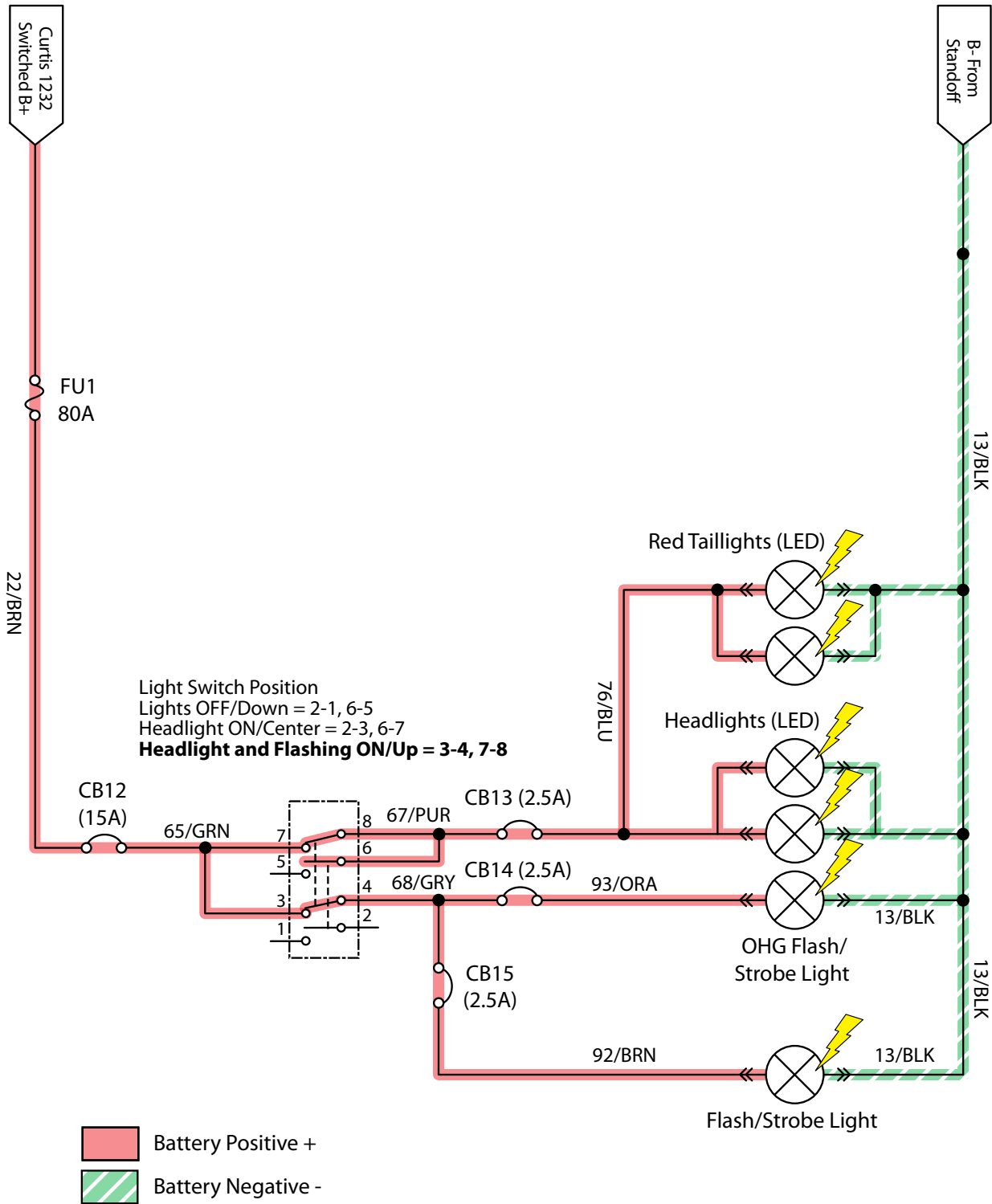

ELC001

Lighting Failed to Turn ON

STEP	ACTION	VALUE(S)	YES	NO
1	<ul style="list-style-type: none"> • Key On • Light switch On • Firmly press circuit breaker #12 to reset • Is circuit breaker #12 tripped? 		Reset and Test Lighting Operation	Go to Step #2
2	<ul style="list-style-type: none"> • Key On • Light switch On • Firmly press circuit breaker #13 (Option) to reset • Is circuit breaker #13 tripped? 		Reset and Test Lighting Operation	Go to Step #3
3	<ul style="list-style-type: none"> • Key On • Light switch On • Firmly press circuit breaker #14 (Option) to reset • Is circuit breaker #14 tripped? 		Reset and Test Lighting Operation	Go to Step #4
4	<ul style="list-style-type: none"> • Key On • Light switch On • Firmly press circuit breaker #15 (Option) to reset • Is circuit breaker #15 tripped? 		Reset and Test Lighting Operation	Go to Step #5
5	<ul style="list-style-type: none"> • Key On • Light switch On • Test voltage applied to the lighting subsystem as shown on the electrical schematic • Are the electrical circuits operating as shown on the electrical schematic? 		Go Back to Step #1	Identify Voltage Drop Location and Repair or Replace Necessary Components

TROUBLESHOOTING

Main Scrub Brushes ON

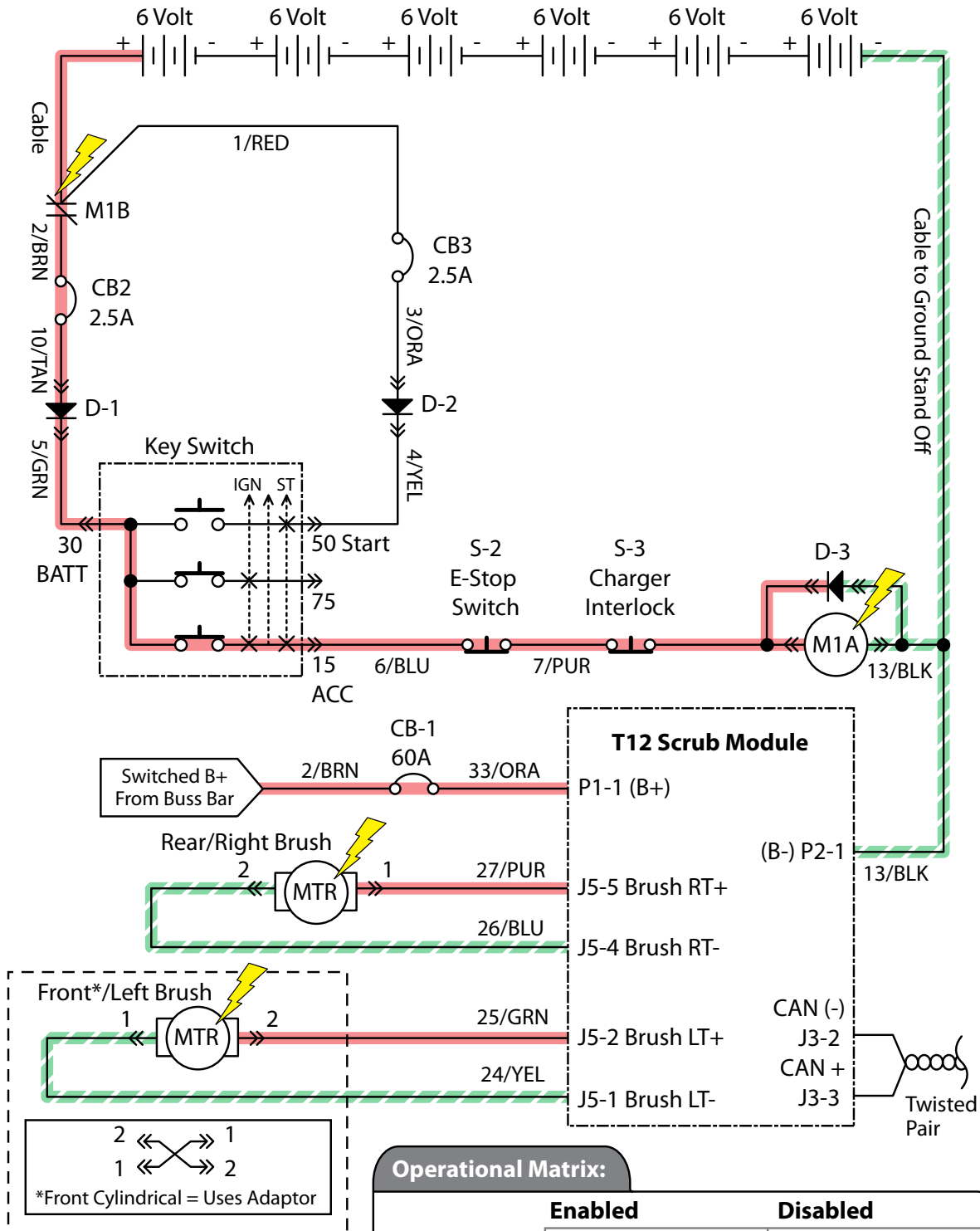

MSC001

Main Scrub Brushes Failed to Turn ON

STEP	ACTION	VALUE(S)	YES	NO
1	<ul style="list-style-type: none"> • Key On • Enable main scrub brushes subsystem • Is there a pertinent LCD warning or fault message displayed? 		See "LCD Warnings" or "LCD Faults" Sections	Go to Step #2
2	<ul style="list-style-type: none"> • Key Off • See "Manual Mode" section of this manual • Activate the main scrub brushes in manual mode • Do the scrub brushes turn On? 		Go to Step #6	Go to Step #3
3	<ul style="list-style-type: none"> • Key Off • See "Self-Test Mode" • Does the Self-Test display output circuits J5-5, J5-4, J5-2, or J5-1 as open or shorted? 		Correct Open or Short Circuit Condition	Go to Step #4
4	<ul style="list-style-type: none"> • Proceed to Step #5 for disk scrub head models • Key Off • Remove cylindrical brushes from scrub head • Check for worn out brushes (see maintenance section) • Check brushes for entangled debris • Check brush idler plugs and bearings for excessive wear, damage, seizure, etc. • Check main brush drive belts for excessive wear, damage, etc • Do any of the above conditions exist? 		Repair or Replace Necessary Cylindrical Scrub Head Components	Go to Step #5
5	<ul style="list-style-type: none"> • Key Off • See TESTING MAIN SCRUB BRUSH MOTORS in the SERVICE section of this manual • Do the scrub brush motors pass the testing? 	See TESTING MAIN SCRUB BRUSH MOTORS	Go to Step #6	Repair or Replace Main Scrub Brush Motors
6	<ul style="list-style-type: none"> • Key Off • Reconnect main scrub brush motors to main harness • Key On • Enable main scrub brush motors • Test voltage applied to the main scrub brush motor subsystem as shown on the electrical schematic • Are the electrical circuits operating as shown on the electrical schematic? 		Go Back to Step #1	Identify Voltage Drop Location and Repair or Replace Necessary Components

Terms:

LCD = Liquid Crystal Display

J5-5 = T12 Scrub Module Connector #5, Pin #5

J5-4 = T12 Scrub Module Connector #5, Pin #4

J5-2 = T12 Scrub Module Connector #5, Pin #2

J5-1 = T12 Scrub Module Connector #5, Pin #1

TROUBLESHOOTING

Power-Up ON

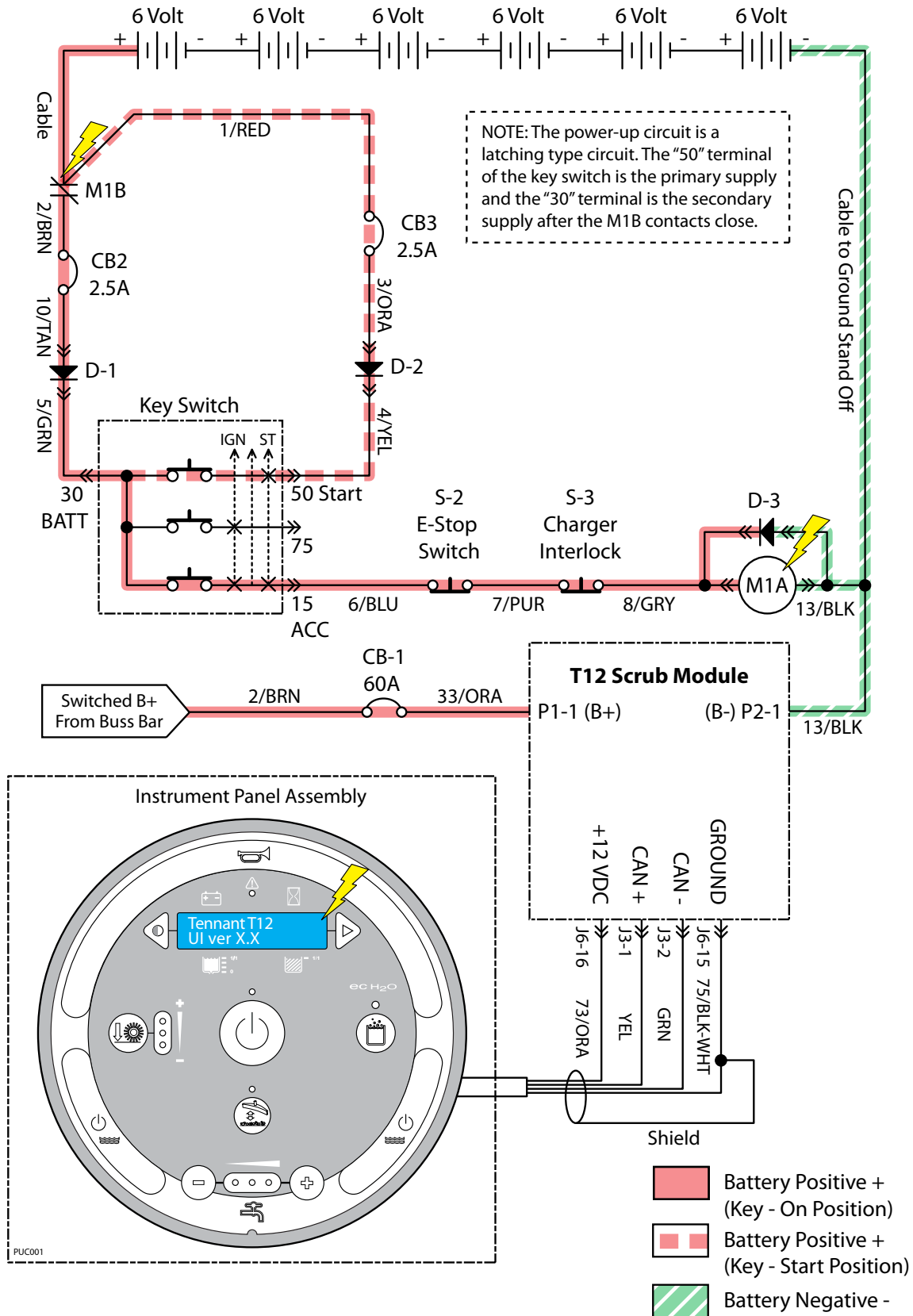

Machine Failed to Power Up

STEP	ACTION	VALUE(S)	YES	NO
1	<ul style="list-style-type: none"> • Key in Start Position • Test the total battery voltage using a voltmeter • Is the total battery voltage greater than 30 VDC? 		Go to Step #2	Recharge Batteries and Test Power-Up Circuit Operation
2	<ul style="list-style-type: none"> • Key Off • Firmly press circuit breaker #2 to reset • Is circuit breaker #2 tripped? 		Reset and Test Power-Up Circuit Operation	Go to Step #3
3	<ul style="list-style-type: none"> • Key Off • Firmly press circuit breaker #3 to reset • Is circuit breaker #3 tripped? 		Reset and Test Power-Up Circuit Operation	Go to Step #4
4	<ul style="list-style-type: none"> • Key Off • Firmly press circuit breaker #1 to reset • Is circuit breaker #1 tripped? 		Reset and Test Power-Up Circuit Operation	Go to Step #5
5	<ul style="list-style-type: none"> • Cycle key switch from Start to On Position • Test voltage applied to the power-up subsystem as shown on the electrical schematic • Are the electrical circuits operating as shown on the electrical schematic? 		Go Back to Step #1	Identify Voltage Drop Location and Repair or Replace Necessary Components

Terms:

VDC = DC Voltage

TROUBLESHOOTING

Propel Subsystem, Forward

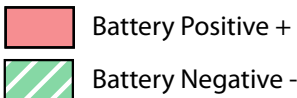
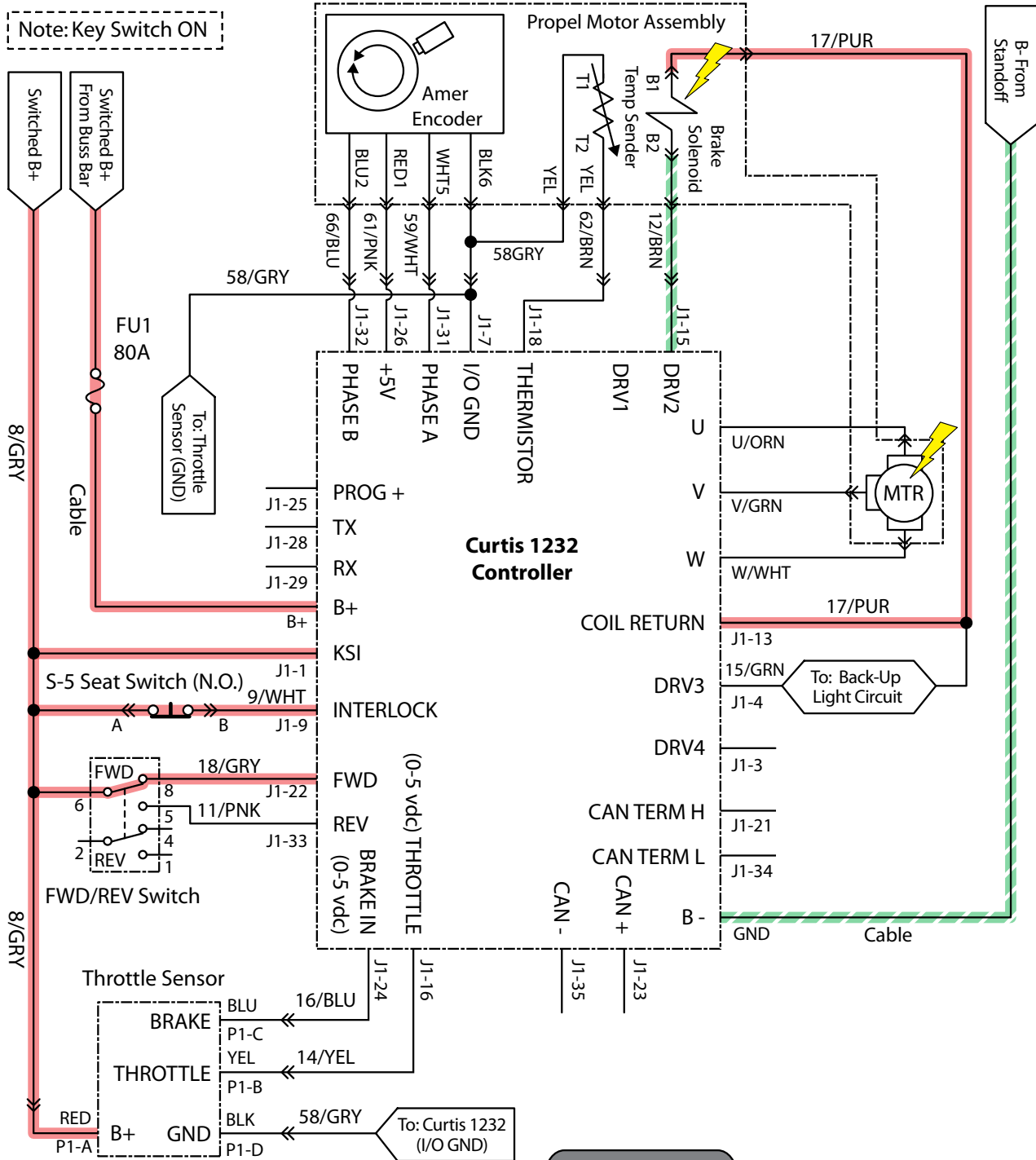

Operational Matrix:		
	Enabled	Disabled
Propel	<ul style="list-style-type: none"> • Seat Switch Closed • Foot Throttle Command • Fwd/Rev Switch Input 	<ul style="list-style-type: none"> • Seat Switch Open • Neutral-Ready State • Brake Command • Curtis 1232 Fault

PMCD14

Machine Failed to Propel

STEP	ACTION	VALUE(S)	YES	NO
1	<ul style="list-style-type: none"> • Key On • See "Curtis 1232 Controller Diagnostics" section of this manual • Does a Curtis 1232 controller fault condition exist? 		Correct Fault Condition	Go to Step #2
2	<ul style="list-style-type: none"> • Key Off • See "Propel Diagnostic Mode" • Is P1:Curtis Online? • Does P2: Throttle input voltage (0-5 vdc) change proportionally with throttle pedal movement? • Does P3 :Brake pedal input turn On/Off with brake pedal activation? • Does P4: Direction input correspond with Fwd/Rev rocker switch position? • Does P5:Speed input from drive assembly encoder (speed, direction, position sensor) read "0000.0 Mph?" • Does P8:Propel motor current read "0000.0 Amps?" • Is the answer "Yes" to all of the above? 		Go to Step #3	Correct Faulty Input Condition
3	<ul style="list-style-type: none"> • Key Off • Place machine on jackstands so drive wheel is lifted off the floor • Enable forward propel • Test voltage applied to the propel subsystem as shown on the electrical schematic • Are the electrical circuits operating as shown on the electrical schematic? 		Go Back to Step #1	Identify Voltage Drop Location and Repair or Replace Necessary Components

Terms:

LCD = Liquid Crystal Display

VDC = Direct Current Voltage

TROUBLESHOOTING

Rear Squeegee Down, OFF

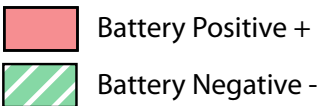
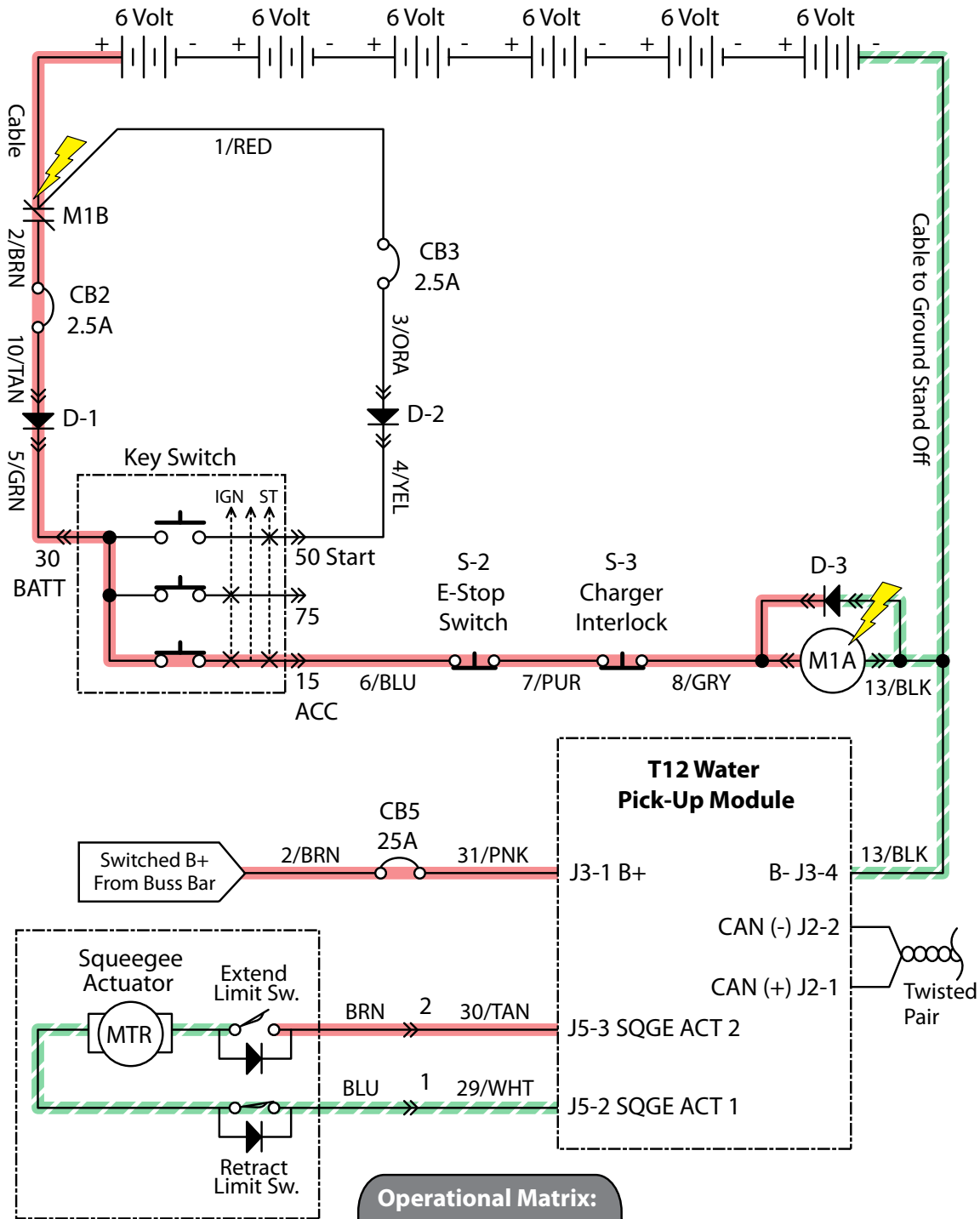

Operational Matrix:		
	Enabled	Disabled
Squeegee Down	<ul style="list-style-type: none"> • 1-STEP Scrub ON • Squeegee/Vac ON 	<ul style="list-style-type: none"> • 1-STEP Scrub OFF • Squeegee/Vac OFF • Reverse Propel • Recovery Tank Full • Very Low Batt Voltage • Load Current Fault

RSL001

Rear Squeegee Failed to Raise/Lower

STEP	ACTION	VALUE(S)	YES	NO
1	<ul style="list-style-type: none"> • Key On • Enable rear squeegee down • Is there a pertinent LCD warning or fault message displayed? 		See "LCD Warnings" or "LCD Faults" Sections	Go to Step #2
2	<ul style="list-style-type: none"> • Key Off • See "Manual Mode" section of this manual • Activate the rear squeegee in manual mode • Does the rear squeegee raise/lower? 		Go to Step #5	Go to Step #3
3	<ul style="list-style-type: none"> • Key Off • See "Self-Test Mode" • Does the Self-Test display output circuits J5-3 and J5-2 as open or shorted? 		Correct Open or Short Circuit Condition	Go to Step #4
4	<ul style="list-style-type: none"> • Key Off • See TESTING REAR SQUEEGEE LIFT ACTUATOR in the SERVICE section of this manual • Does the rear squeegee lift actuator pass the testing? 	See TESTING REAR SQUEEGEE LIFT ACTUATOR in the SERVICE section of this manual.	Go to Step #5	Replace Rear Squeegee Lift Actuator
5	<ul style="list-style-type: none"> • Key Off • Reconnect rear squeegee lift actuator to main wire harness • Test voltage applied to rear squeegee lift subsystem as shown on the electrical schematic • Are the electrical circuits operating as shown on the electrical schematic? 		Go Back to Step #1	Identify Voltage Drop Location and Repair or Replace Necessary Components

Terms:

LCD = Liquid Crystal Display

J5-3 = Water PU Module Connector #5, Pin #3

J5-2 = Water PU Module Connector #5, Pin #2

TROUBLESHOOTING

Scrub Head Lift

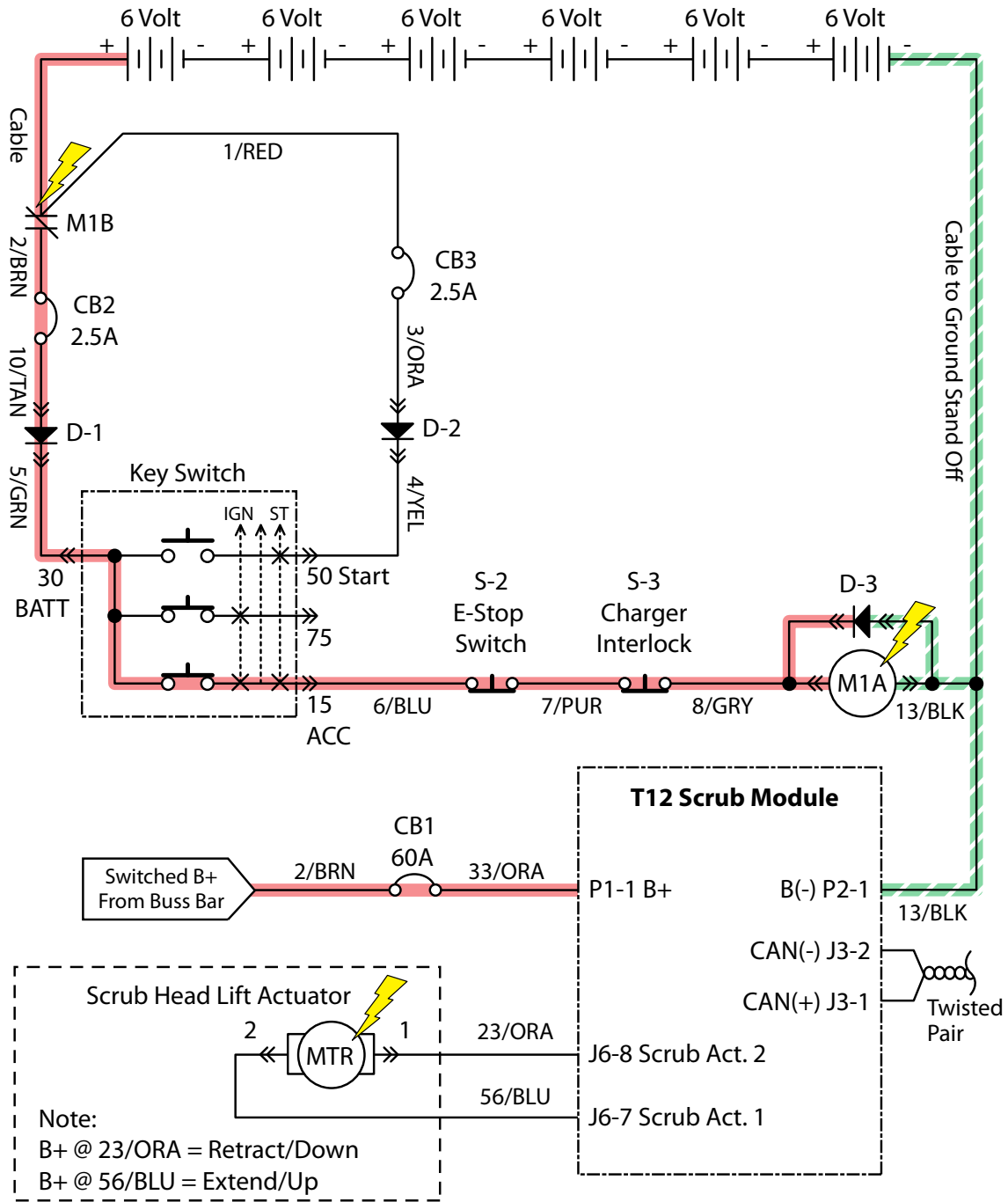

Operational Matrix:

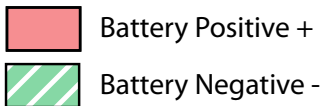

	Enabled	Disabled
Scrub Head Down	<ul style="list-style-type: none"> 1-STEP Scrub ON Fwd/Rev Propel 	<ul style="list-style-type: none"> 1-STEP Scrub OFF Neutral-Ready State Recovery Tank Full Solution Tank Empty Very Low Batt Voltage Load Current Fault

MSL001

Scrub Head Failed to Raise/Lower

STEP	ACTION	VALUE(S)	YES	NO
1	<ul style="list-style-type: none"> • Key On • Enable scrub head down • Is there a pertinent LCD warning or fault message displayed? 		See "LCD Warnings" or "LCD Faults" Sections	Go to Step #2
2	<ul style="list-style-type: none"> • Key Off • See "Manual Mode" section of this manual • Activate the scrub head in manual mode • Does the scrub head raise/lower? 		Go to Step #5	Go to Step #3
3	<ul style="list-style-type: none"> • Key Off • See "Self-Test Mode" • Does the Self-Test display output circuits J6-8 and J6-7 as open or shorted? 		Correct Open or Short Circuit Condition	Go to Step #4
4	<ul style="list-style-type: none"> • Key Off • See TESTING MAIN BRUSH LIFT ACTUATOR in the SERVICE section of this manual • Does the scrub head lift actuator pass the testing? 	See TESTING MAIN BRUSH LIFT ACTUATOR	Go to Step #5	Replace Scrub Head Lift Actuator
5	<ul style="list-style-type: none"> • Key Off • Reconnect scrub head lift actuator to main wire harness • Test voltage applied to scrub head lift subsystem as shown on the electrical schematic • Are the electrical circuits operating as shown on the electrical schematic? 		Go Back to Step #1	Identify Voltage Drop Location and Repair or Replace Necessary Components

Terms:

LCD = Liquid Crystal Display

J6-8 = Scrub Module Connector #6, Pin #8

J6-7 = Scrub Module Connector #6, Pin #7

TROUBLESHOOTING

Side Brush ON (Option)

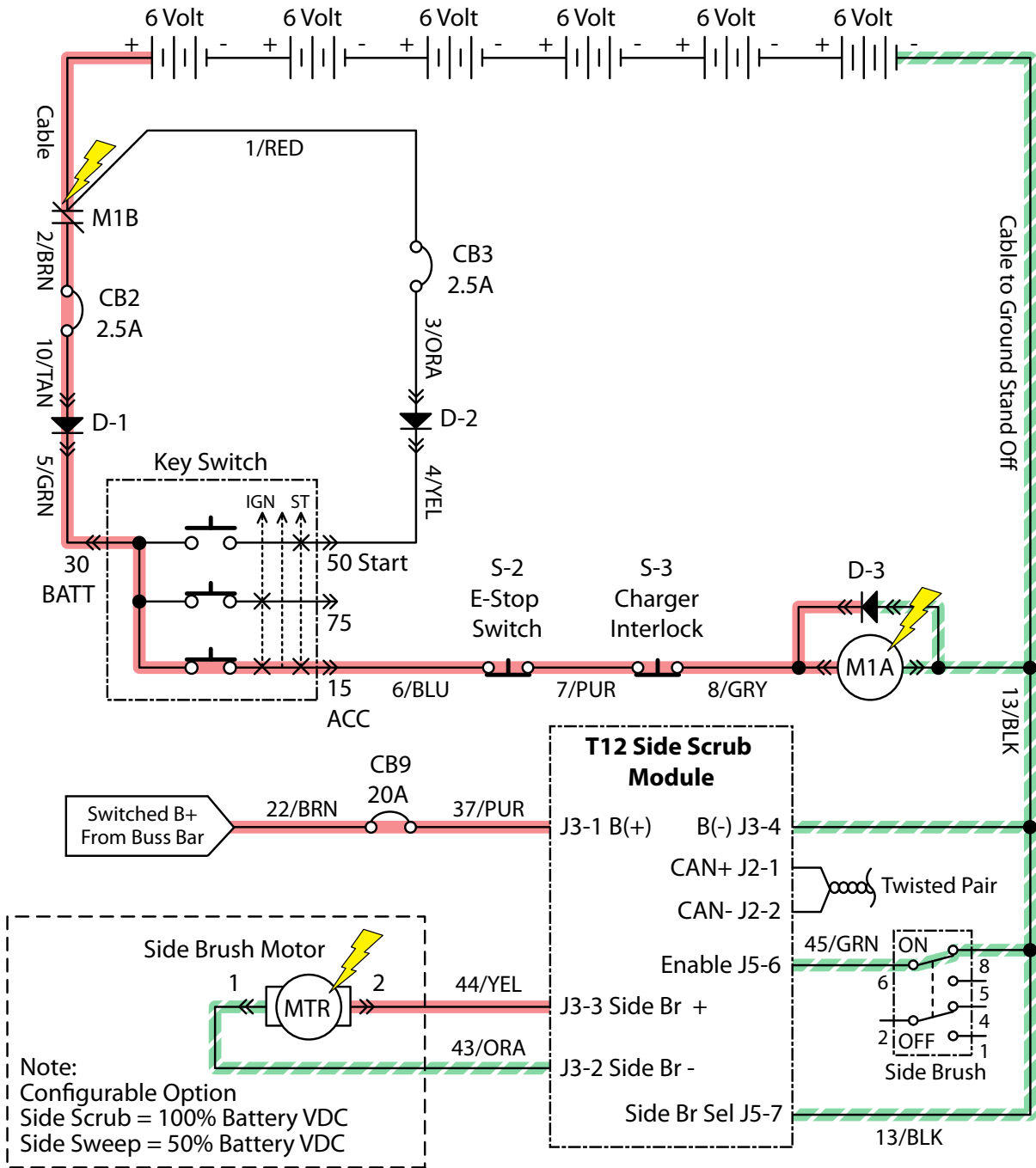

Note:
Configurable Option
Side Scrub = 100% Battery VDC
Side Sweep = 50% Battery VDC

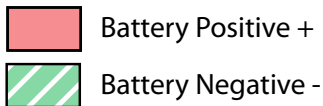

Operational Matrix:

	Enabled	Disabled
Side Brush	<ul style="list-style-type: none"> • 1-STEP Scrub ON • Side Brush Switch ON • Fwd/Rev Propel 	<ul style="list-style-type: none"> • 1-STEP Scrub OFF • Side Brush Switch OFF • Recovery Tank Full • Solution Tank Empty • Very Low Batt Voltage • Load Current Fault • Neutral (Ready State)

SBC001

Side Brush Failed to Turn ON (Option)

STEP	ACTION	VALUE(S)	YES	NO
1	<ul style="list-style-type: none"> Key On Enable side brush Is there a pertinent LCD warning or fault message displayed? 		See "LCD Warnings" or "LCD Faults" Sections	Go to Step #2
2	<ul style="list-style-type: none"> Key Off See "Manual Mode" section of this manual Activate the side brush in manual mode Do the side brush turn On? 		Go to Step #6	Go to Step #3
3	<ul style="list-style-type: none"> Key Off See "Self-Test Mode" Does the Self-Test display output circuits J3-3 and J3-2 as open or shorted? 		Correct Open or Short Circuit Condition	Go to Step #4
4	<ul style="list-style-type: none"> Key Off See "Input Display Mode" Does I7: Side Br On/Off input correspond with side brush rocker switch position? 		Go to Step #5	Correct Faulty Input Condition
5	<ul style="list-style-type: none"> Key Off See TESTING SIDE BRUSH MOTOR in the SERVICE section of this manual Does the side brush motor pass the testing? 	See TESTING SIDE BRUSH MOTOR	Go to Step #6	Replace Side Brush Motor
6	<ul style="list-style-type: none"> Key Off Reconnect side brush motor to main wire harness Test voltage applied to side brush subsystem as shown on the electrical schematic Are the electrical circuits operating as shown on the electrical schematic? 		Go Back to Step #1	Identify Voltage Drop Location and Repair or Replace Necessary Components

Terms:

LCD = Liquid Crystal Display

J3-2 = Side Scrub Module Connector #3, Pin #2

J3-3 = Side Scrub Module Connector #3, Pin #3

TROUBLESHOOTING

Side Brush Extend/Down, OFF (Option)

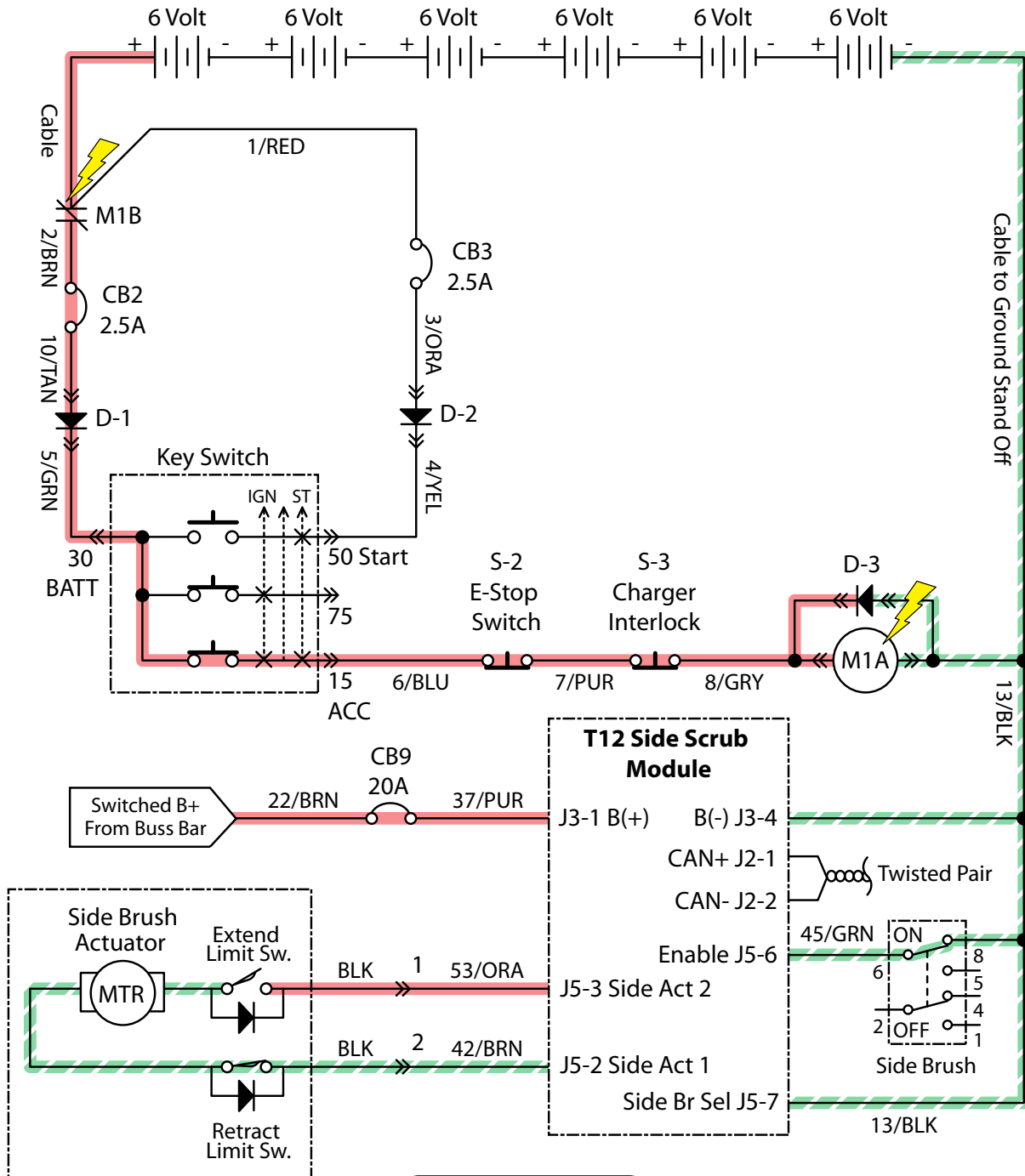

Operational Matrix:

	Enabled	Disabled
Side Brush Extend/Down	<ul style="list-style-type: none"> • 1-STEP Scrub ON • Side Brush Switch ON 	<ul style="list-style-type: none"> • 1-STEP Scrub OFF • Side Brush Switch OFF • Recovery Tank Full • Solution Tank Empty • Very Low Batt Voltage • Load Current Fault

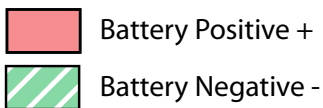

SBC002

Side Brush Failed to Extend/Lower (Option)

STEP	ACTION	VALUE(S)	YES	NO
1	<ul style="list-style-type: none"> • Key On • Enable side brush extend/down • Is there a pertinent LCD warning or fault message displayed? 		See "LCD Warnings" or "LCD Faults" Sections	Go to Step #2
2	<ul style="list-style-type: none"> • Key Off • See "Manual Mode" section of this manual • Extend/Lower the side brush in manual mode • Does the side brush extend/lower? 		Go to Step #6	Go to Step #3
3	<ul style="list-style-type: none"> • Key Off • See "Self-Test Mode" • Does the Self-Test display output circuits J5-3 and J5-2 as open or shorted? 		Correct Open or Short Circuit Condition	Go to Step #4
4	<ul style="list-style-type: none"> • Key Off • See "Input Display Mode" • Does I7: Side Br On/Off input correspond with side brush rocker switch position? 		Go to Step #5	Correct Faulty Input Condition
5	<ul style="list-style-type: none"> • Key Off • See TESTING SIDE BRUSH LIFT ACTUATOR in the SERVICE section of this manual • Does the side brush lift actuator pass the testing? 	See TESTING SIDE BRUSH LIFT ACTUATOR	Go to Step #6	Replace Side Brush Lift Actuator
6	<ul style="list-style-type: none"> • Key Off • Reconnect side brush lift actuator to main wire harness • Key On • Side brush extend/down enabled • Test voltage applied to side brush lift subsystem as shown on the electrical schematic • Are the electrical circuits operating as shown on the electrical schematic? 		Go Back to Step #1	Identify Voltage Drop Location and Repair or Replace Necessary Components

Terms:

LCD = Liquid Crystal Display

J5-2 = Side Scrub Module Connector #5, Pin #2

J5-3 = Side Scrub Module Connector #5, Pin #3

TROUBLESHOOTING

Side Brush Retract/Up, OFF (Option)

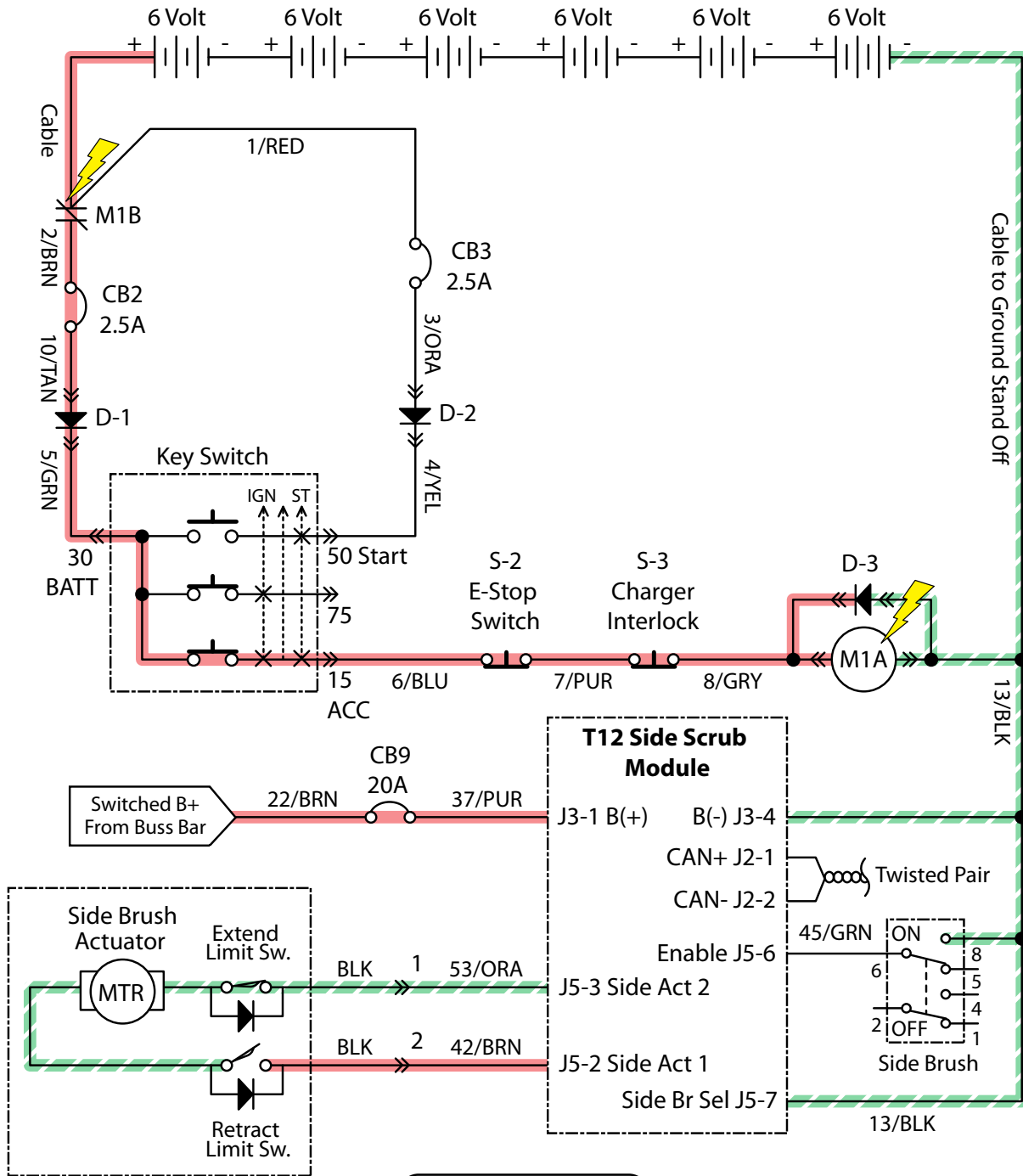

Operational Matrix:

Side Brush Retract/Up

Enabled

- 1-STEP Scrub OFF
- Side Brush Switch OFF
- Recovery Tank Full
- Solution Tank Empty
- Very Low Batt Voltage
- Load Current Fault

Disabled

- 1-STEP Scrub ON
- Side Brush Switch ON

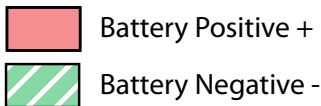

SBC003

Side Brush Failed to Retract/Raise (Option)

STEP	ACTION	VALUE(S)	YES	NO
1	<ul style="list-style-type: none"> Key On Enable side brush retract/up Is there a pertinent LCD warning or fault message displayed? 		See "LCD Warnings" or "LCD Faults" Sections	Go to Step #2
2	<ul style="list-style-type: none"> Key Off See "Self-Test Mode" Does the Self-Test display output circuits J5-3 and J5-2 as open or shorted? 		Correct Open or Short Circuit Condition	Go to Step #3
3	<ul style="list-style-type: none"> Key Off See "Input Display Mode" Does I7: Side Br On/Off input correspond with side brush rocker switch position? 		Go to Step #4	Correct Faulty Input Condition
4	<ul style="list-style-type: none"> Key Off See TESTING SIDE BRUSH LIFT ACTUATOR in the SERVICE section of this manual Does the side brush lift actuator pass the testing? 	See TESTING SIDE BRUSH LIFT ACTUATOR	Go to Step #5	Replace Side Brush Lift Actuator
5	<ul style="list-style-type: none"> Key On Side brush switch Off Test voltage applied to side brush lift subsystem as shown on the electrical schematic Are the electrical circuits operating as shown on the electrical schematic? 		Go Back to Step #1	Identify Voltage Drop Location and Repair or Replace Necessary Components

Terms:

LCD = Liquid Crystal Display

J5-2 = Side Scrub Module Connector #5, Pin #2

J5-3 = Side Scrub Module Connector #5, Pin #3

TROUBLESHOOTING

Solution Control ON - Main Brush (Conventional)

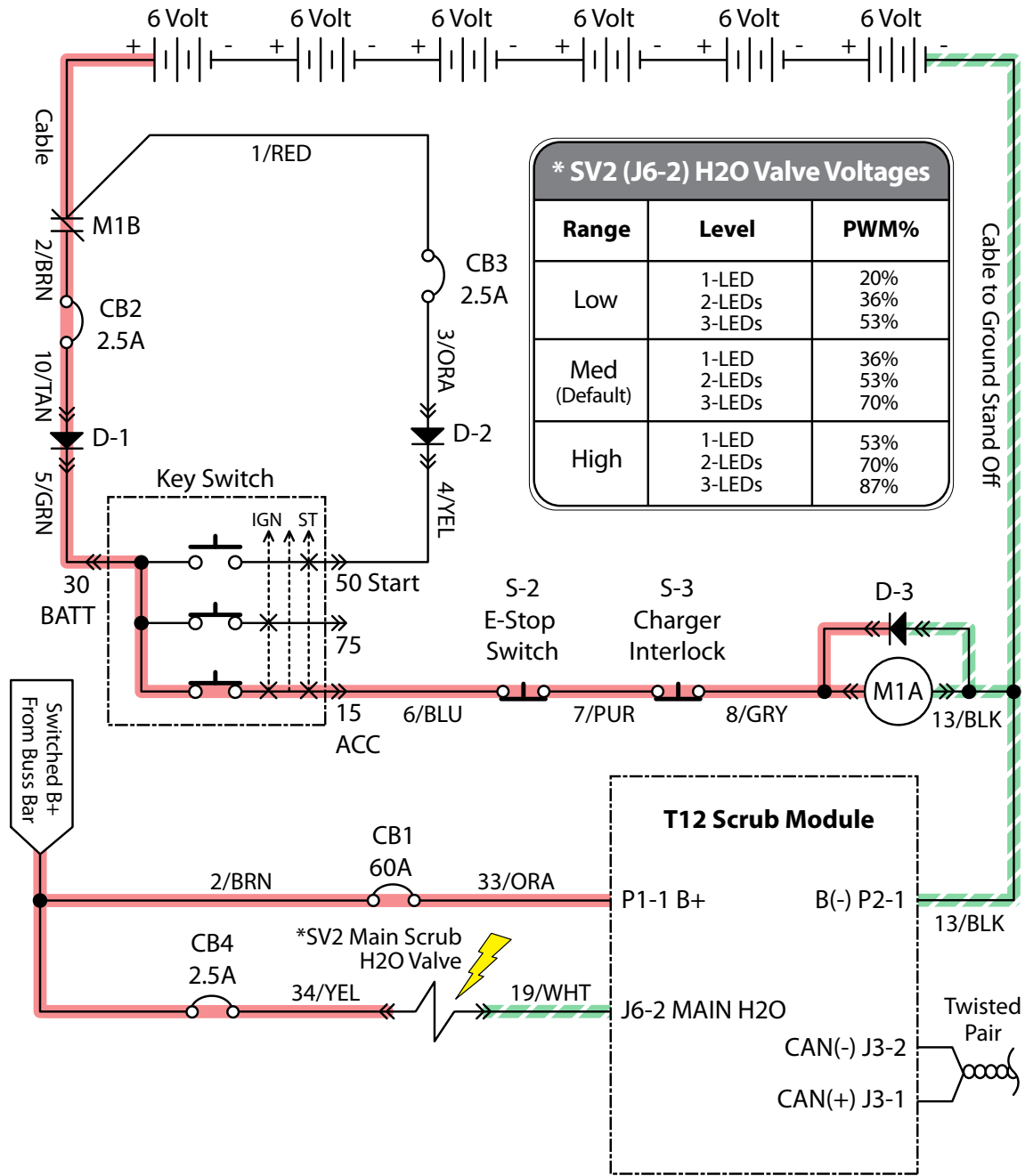

Operational Matrix:

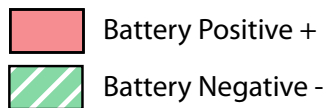

	Enabled	Disabled
Solution Control - Main (Conventional)	<ul style="list-style-type: none"> • 1-STEP Scrub ON • Solution Control ON • Fwd/Rev Propel 	<ul style="list-style-type: none"> • 1-STEP Scrub OFF • Solution Control OFF • Neutral-Ready State • Recovery Tank Full • Solution Tank Empty • Very Low Batt Voltage • Load Current Fault

CSC002

Solution Control Failed to Turn ON - Main Brush (Conventional)

STEP	ACTION	VALUE(S)	YES	NO
1	<ul style="list-style-type: none"> • Key On • Enable solution control (conventional) • Is there a pertinent LCD warning or fault message displayed? 		See "LCD Warnings" or "LCD Faults" Sections	Go to Step #2
2	<ul style="list-style-type: none"> • Key Off • See "Manual Mode" section of this manual • Activate solution control in manual mode • Does the machine dispense water to the floor? 		Go to Step #7	Go to Step #3
3	<ul style="list-style-type: none"> • Key Off • See "Self-Test Mode" • Does the Self-Test display output circuit J6-2 as open or shorted? 		Correct Open or Short Circuit Condition	Go to Step #4
4	<ul style="list-style-type: none"> • Key Off • Firmly press circuit breaker #4 to reset • Is circuit breaker #4 tripped? 		Reset and Test Solution Control Operation	Go to Step #5
5	<ul style="list-style-type: none"> • Key Off • Disconnect SV2 from main wire harness • Apply battery voltage to SV2 using fuse-protected jumper leads • Does the main brush dispense solution? 		Go to Step #6	Repair or Replace SV2
6	<ul style="list-style-type: none"> • Key Off • Reconnect SV2 to main wire harness • Key On • Enable solution control (conventional) • Test voltage applied to solution control subsystem as shown on the electrical schematic • Are the electrical circuits operating as shown on the electrical schematic? 		Go Back to Step #1	Identify Voltage Drop Location and Repair or Replace Necessary Components

Terms:

LCD = Liquid Crystal Display

J6-2 = Scrub Module Connector #6, Pin #2

SV2 = Solenoid Valve #2 (Main Brush)

TROUBLESHOOTING

Solution Control ON - Side Brush (Conventional)

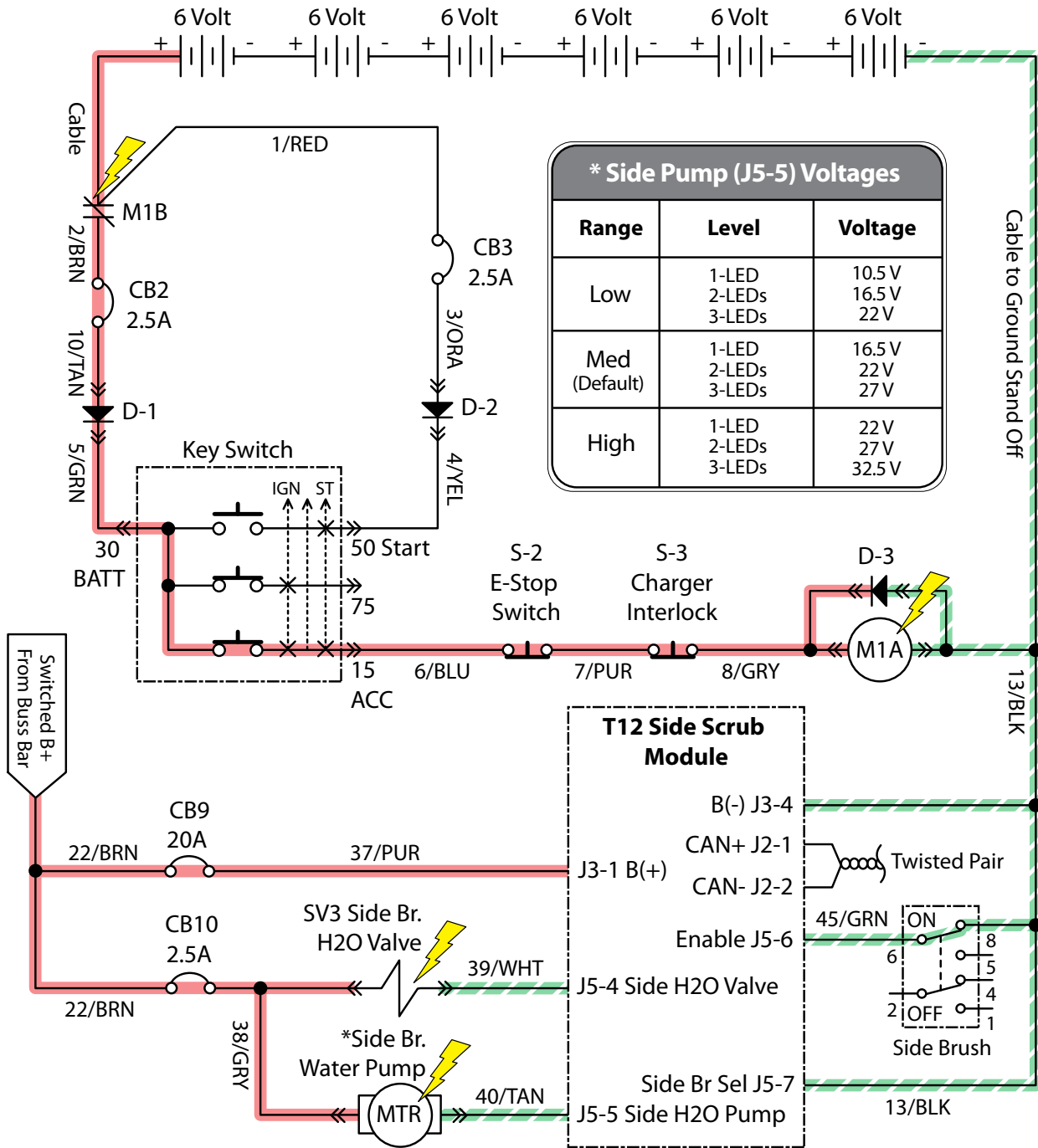

Operational Matrix:

	Enabled	Disabled
Solution Control-Side (Conventional)	<ul style="list-style-type: none"> • 1-STEP Scrub ON • Side Brush Switch ON • Fwd/Rev Propel 	<ul style="list-style-type: none"> • 1-STEP Scrub OFF • Side Brush Switch OFF • Recovery Tank Full • Solution Tank Empty • Very Low Batt Voltage • Load Current Fault • Neutral (Ready State)

SBC004

Solution Control Failed to Turn ON - Side Brush (Conventional)

STEP	ACTION	VALUE(S)	YES	NO
1	<ul style="list-style-type: none"> • Key On • Enable side brush solution control (conventional) • Is there a pertinent LCD warning or fault message displayed? 		See "LCD Warnings" or "LCD Faults" Sections	Go to Step #2
2	<ul style="list-style-type: none"> • Key Off • See "Manual Mode" section of this manual • Activate solution control in manual mode • Does the machine dispense water to the side brush? 		Go to Step #7	Go to Step #3
3	<ul style="list-style-type: none"> • Key Off • See "Self-Test Mode" • Does the Self-Test display output circuits J5-4 or J5-5 as open or shorted? 		Correct Open or Short Circuit Condition	Go to Step #4
4	<ul style="list-style-type: none"> • Key Off • Firmly press circuit breaker #9 to reset • Is circuit breaker #9 tripped? 		Reset and Test Solution Control Operation	Go to Step #5
5	<ul style="list-style-type: none"> • Key Off • Firmly press circuit breaker #10 to reset • Is circuit breaker #10 tripped? 		Reset and Test Solution Control Operation	Go to Step #6
6	<ul style="list-style-type: none"> • Key Off • Disconnect SV3 and side brush water pump from main wire harness • Apply battery voltage to SV3 and side brush water pump using fuse-protected jumper leads • Does the side brush dispense solution? 		Go to Step #7	Repair or Replace SV3 or Side Brush Water Pump
7	<ul style="list-style-type: none"> • Key Off • Reconnect SV3 and side brush water pump to main wire harness • Key On • Enable side brush solution control (conventional) • Test voltage applied to the side brush solution control subsystem as shown on the electrical schematic • Are the electrical circuits operating as shown on the electrical schematic? 		Go Back to Step #1	Identify Voltage Drop Location and Repair or Replace Necessary Components

Terms:

LCD = Liquid Crystal Display

J5-4 = Side Scrub Module Connector #5, Pin #4

J5-5 = Side Scrub Module Connector #5, Pin #5

SV3 = Solenoid Valve #3 (Side Brush)

TROUBLESHOOTING

Solution Control ON (ec-H2O)

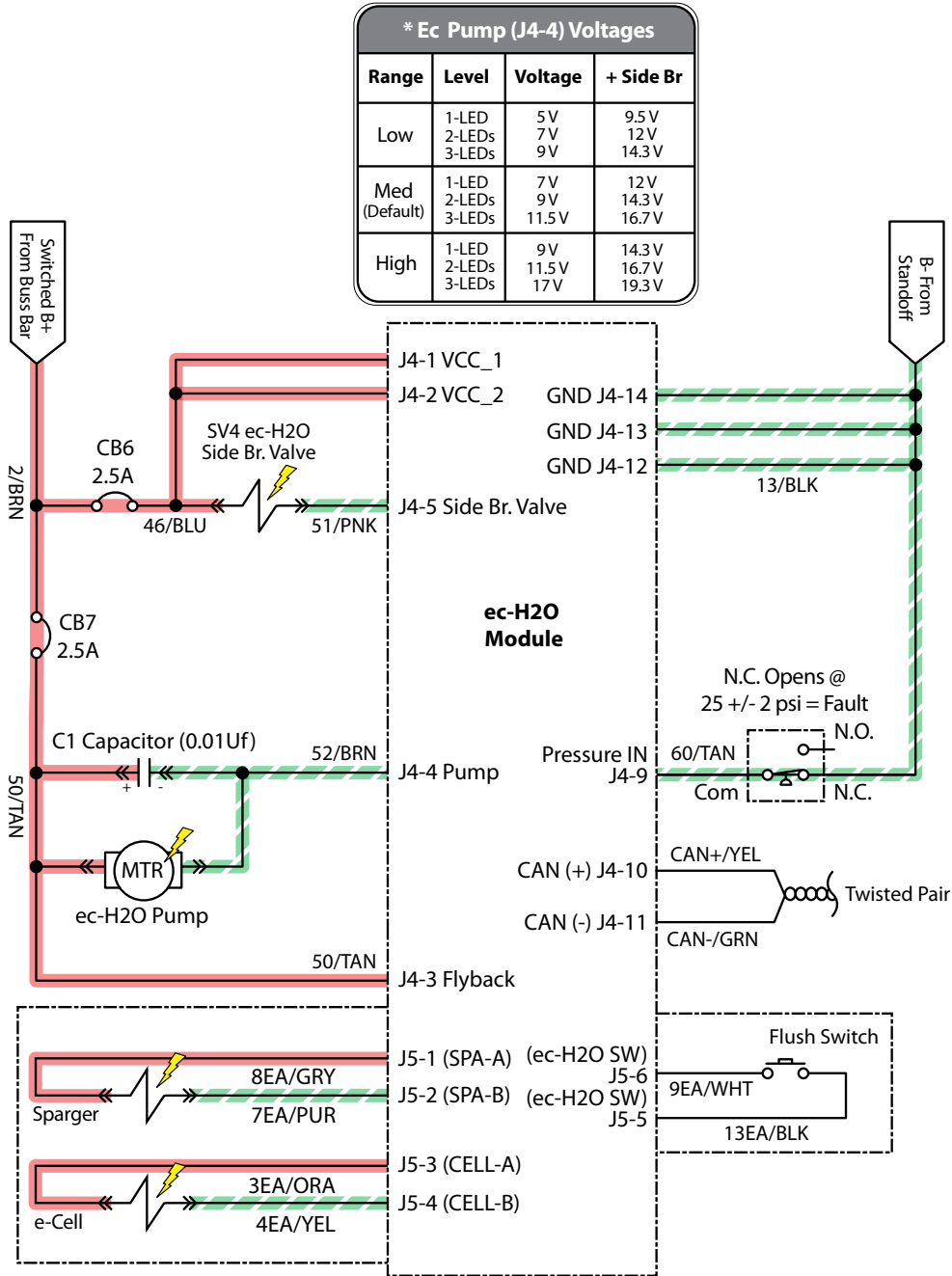

ECC001

Solution Control Failed to Turn ON (*ec-H2O*)

STEP	ACTION	VALUE(S)	YES	NO
1	<ul style="list-style-type: none"> Key On Enable solution control (<i>ec-H2O</i>) Is there a pertinent LCD warning or fault message displayed? 		See "LCD Warnings" or "LCD Faults" Sections	Go to Step #2
2	<ul style="list-style-type: none"> Key Off Firmly press circuit breakers #6 and #7 to reset Is a circuit breaker tripped? 		Reset and Test <i>ec-H2O</i> Solution Control Operation	Go to Step #3
3	<ul style="list-style-type: none"> Key Off Enable solution control (<i>ec-H2O</i>) Is the <i>ec-H2O</i> LED flashing RED, indicating a system restriction or low water conductivity*? 		See " <i>ec-H2O</i> Module Flush Procedure" Section. Then Proceed to Step #4	Go to Step #5
4	<ul style="list-style-type: none"> Key Off See "<i>ec-H2O</i> Module Flush Procedure" section of this manual Did the flush procedure fix the problem? 		System OK	See "Testing <i>ec-H2O</i> Pressure Switch"
5	<ul style="list-style-type: none"> Key Off See "Manual Mode" section of this manual Activate solution control (<i>ec-H2O</i>) in manual mode Does solution control (<i>ec-H2O</i>) turn On? 		Go to Step #8	Go to Step #6
6	<ul style="list-style-type: none"> Key Off See "Self-Test Mode" Does the Self-Test display output circuits J4-4, J4-5, J5-1, or J5-2, J5-3, or J5-4 as open or shorted? 	See "Self-Test Mode"	Correct Open or Short Circuit Condition	Go to Step #7
7	<ul style="list-style-type: none"> Key Off Disconnect <i>ec-H2O</i> water pump from wire harness Apply battery voltage to <i>ec-H2O</i> water pump using fuse-protected jumper leads Does the <i>ec-H2O</i> water pump dispense water? 		Go to Step #8	Repair or Replace <i>ec-H2O</i> Water Pump
8	<ul style="list-style-type: none"> Key Off Reconnect <i>ec-H2O</i> water pump to wire harness Key On Enable solution control (<i>ec-H2O</i>) Test voltage applied to solution control (<i>ec-H2O</i>) system as shown on the electrical schematic Are the electrical circuits operating as shown on the electrical schematic? 		Go to Step #9	Identify Voltage Drop Location and Repair or Replace Necessary Components
9	<ul style="list-style-type: none"> Key On Enable solution control (<i>ec-H2O</i>) Is the <i>ec-H2O</i> LED solid RED, indicating an overcurrent condition on a system component? 		Replace <i>ec-H2O</i> Module	Go Back to Step #1

*NOTE: Add 1/2 tablespoon of salt for every 10 gallons of water in the solution tank to increase water conductivity.

Terms:

LCD = Liquid Crystal Display

LED = Light Emitting Diode

J4-4 = *ec-H2O* Module Connector #4, Pin #4

J4-5 = *ec-H2O* Module Connector #4, Pin #5

J5-1 = *ec-H2O* Module Connector #5, Pin #1

J5-2 = *ec-H2O* Module Connector #5, Pin #2

J5-3 = *ec-H2O* Module Connector #5, Pin #3

J5-4 = *ec-H2O* Module Connector #5, Pin #4

TROUBLESHOOTING

Spray Nozzle ON (Option)

Note: Key Switch ON

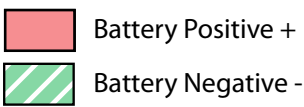
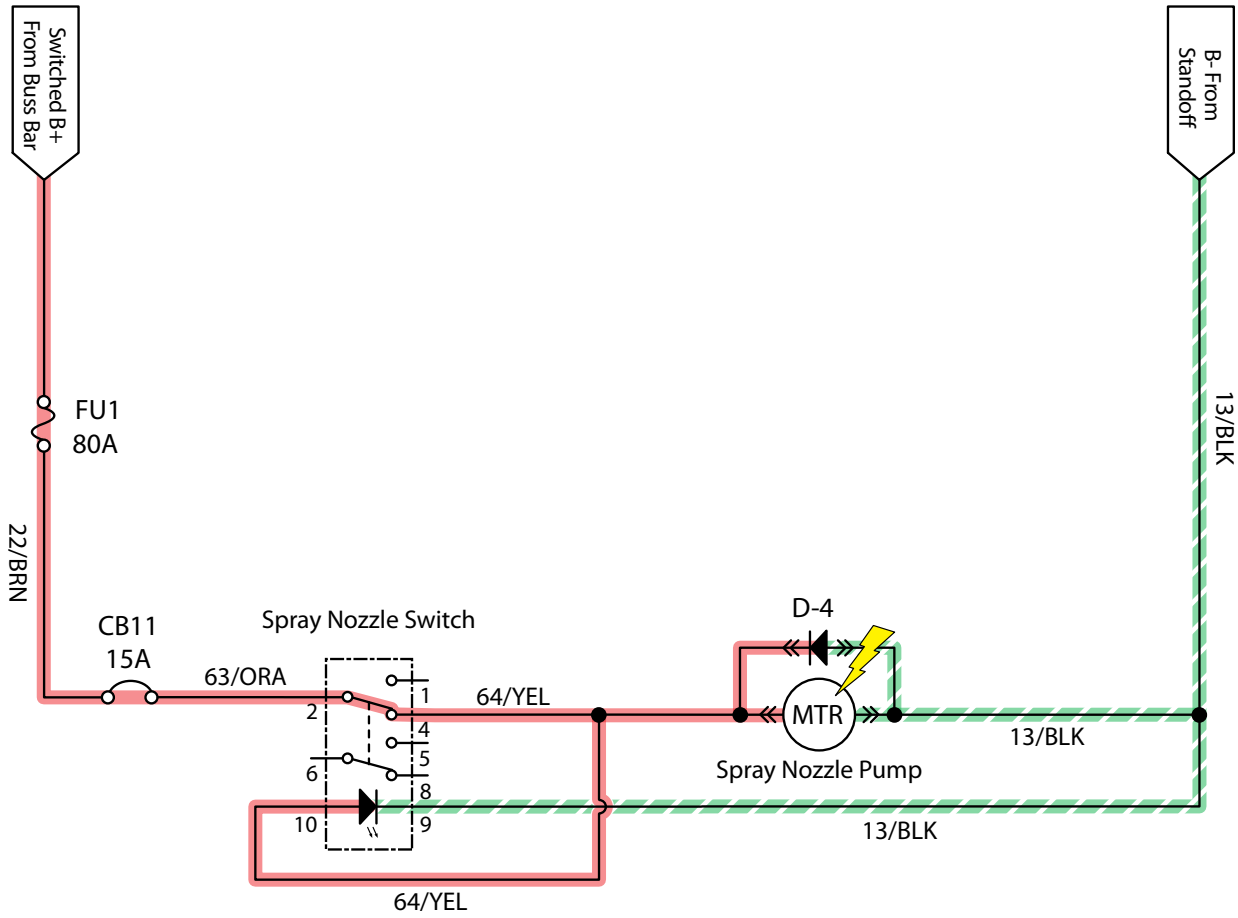

SNC001

Spray Nozzle Failed to Turn ON (Option)

STEP	ACTION	VALUE(S)	YES	NO
1	<ul style="list-style-type: none"> • Key On • Enable spray nozzle subsystem • Is there a pertinent LCD warning or fault message displayed? 		See "LCD Warnings" or "LCD Faults" Sections	Go to Step #2
2	<ul style="list-style-type: none"> • Key Off • Firmly press circuit breaker #11 to reset • Is circuit breaker #11 tripped? 		Reset and Test Spray Nozzle Operation	Go to Step #3
3	<ul style="list-style-type: none"> • Key Off • Disconnect spray nozzle water pump from wire harness • Apply battery voltage to spray nozzle water pump using fuse-protected jumper leads • Does the spray nozzle water pump dispense water? 		Go to Step #4	Repair or Replace Spray Nozzle Water Pump
4	<ul style="list-style-type: none"> • Key Off • Reconnect spray nozzle water pump to wire harness • Key On • Turn spray nozzle switch On • Test voltage applied to spray nozzle subsystem as shown on the electrical schematic • Are the electrical circuits operating as shown on the electrical schematic? 		Go Back to Step #1	Identify Voltage Drop Location and Repair or Replace Necessary Components

TROUBLESHOOTING

Vacuum Fan ON

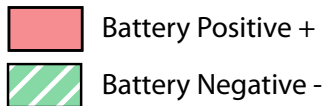
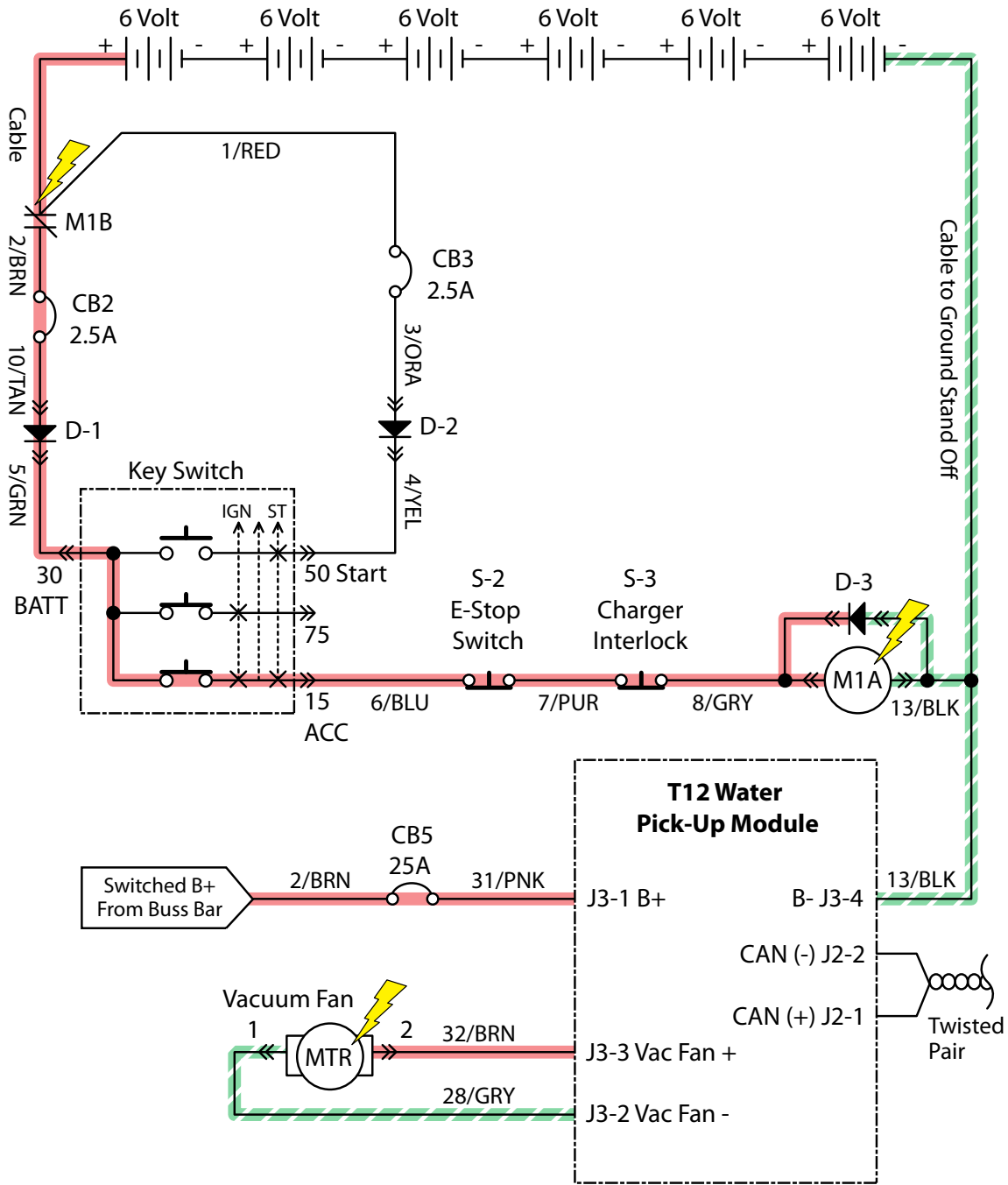

Operational Matrix:		
	Enabled	Disabled
Vacuum Fan	<ul style="list-style-type: none"> • 1-STEP Scrub ON • Squeegee/Vac ON 	<ul style="list-style-type: none"> • 1-STEP Scrub OFF • Squeegee/Vac OFF • Recovery Tank Full • Very Low Batt Voltage • Load Current Fault

VFC002

Vacuum Fan Failed to Turn ON

STEP	ACTION	VALUE(S)	YES	NO
1	<ul style="list-style-type: none"> • Key On • Enable scrubbing vacuum fan(s) • Is there a pertinent LCD warning or fault message displayed? 		See "LCD Warnings" or "LCD Faults" Sections	Go to Step #2
2	<ul style="list-style-type: none"> • Key Off • See "Manual Mode" section of this manual • Activate vacuum fan(s) in manual mode • Does the vacuum fan(s) turn On? 		Go to Step #5	Go to Step #3
3	<ul style="list-style-type: none"> • Key Off • See "Self-Test Mode" • Does the Self-Test display output circuits J3-3, or J3-2 as open or shorted? 		Correct Open or Short Circuit Condition	Go to Step #4
4	<ul style="list-style-type: none"> • Key Off • See TESTING VACUUM FAN (SCRUBBING) in the SERVICE section of this manual • Do the vacuum fan motor pass the testing? 	See TESTING VACUUM FAN (SCRUBBING)	Go to Step #5	Repair or Replace Vacuum Fan Motor
5	<ul style="list-style-type: none"> • Key Off • Reconnect vacuum fan motor to main wire harness • Key On • Enable scrubbing vacuum fan subsystem • Test voltage applied to the scrubbing vacuum fan subsystem as shown on the electrical schematic • Are the electrical circuits operating as shown on the electrical schematic? 		Go Back to Step #1	Identify Voltage Drop Location and Repair or Replace Necessary Components

Terms:

LCD = Liquid Crystal Display

J3-3 = Water PU Module Connector #3, Pin #3

J3-2 = Water PU Module Connector #3, Pin #2

SECTION 5

Contents	Page	Contents	Page
SERVICE		COMPONENT TESTING (CONTINUED)	
SERVICE PROCEDURES.....	5-2	REAR SQGE LIFT ACTUATOR.....	5-35
REAR SQUEEGEE LIFT ACTUATOR	5-2	VACUUM FAN.....	5-36
REMOVAL.....	5-2	MAIN SCRUB BRUSH MOTORS	5-37
INSTALLATION	5-3	SIDE BRUSH MOTOR	5-38
SIDE BRUSH LIFT ACTUATOR.....	5-4	EC-H2O PUMP	5-39
REMOVAL.....	5-4	EC-H2O PRESSURE SWITCH	5-40
INSTALLATION	5-4		
ADJUSTING SIDE BRUSH			
SPRING TUBE ASSEMBLY.....	5-5		
SIDE BRUSH MOTOR	5-6		
REMOVAL.....	5-6		
INSTALLATION	5-7		
CARBON BRUSHES.....	5-7		
MAIN BRUSH LIFT ACTUATOR.....	5-8		
REMOVAL.....	5-8		
INSTALLATION	5-8		
MAIN SCRUB HEAD	5-9		
REMOVAL.....	5-9		
INSTALLATION	5-10		
MAIN SCRUB BRUSH MOTOR			
(CYLINDRICAL)	5-11		
REMOVAL	5-11		
INSTALLATION.....	5-12		
CARBON BRUSHES	5-12		
INSTRUMENT PANEL.....	5-13		
REMOVAL.....	5-13		
INSTALLATION	5-13		
LOGIC BOARD REPLACEMENT.....	5-14		
REMOVAL.....	5-14		
INSTALLATION	5-15		
STEERING WHEEL TIMING.....	5-16		
WHEEL DRIVE ASSEMBLY	5-17		
REMOVAL.....	5-17		
INSTALLATION	5-18		
TIRE REPLACEMENT.....	5-19		
VACUUM FAN ASSEMBLY	5-20		
REMOVAL	5-20		
INSTALLATION	5-21		
COMPONENT TESTING.....	5-22		
TANK LEVEL SENSORS	5-22		
PARKING BRAKE, ELECTROMAGNETIC ..	5-24		
PROPEL MOTOR (AND ENCODER).....	5-27		
PROPEL MOTOR CABLES.....	5-29		
THROTTLE/BRAKE SENSOR	5-31		
SIDE BRUSH LIFT ACTUATOR.....	5-33		
MAIN BRUSH LIFT ACTUATOR.....	5-34		

SERVICE

REAR SQUEEGEE LIFT ACTUATOR

REMOVING REAR SQUEEGEE LIFT ACTUATOR

FOR SAFETY: Before leaving or servicing machine, stop on level surface, turn off machine and remove key.

1. Drain solution and recovery tanks.
2. Remove rear squeegee and set aside.



3. Chock front drive tire and place rear wheels on blocks.

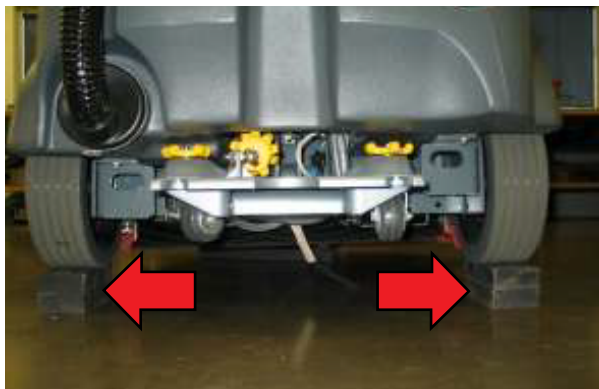

4. Proceed to next step if actuator failed in lowered position. Carefully support rear squeegee mounting bracket using a floor jack. Do not apply excessive force.



5. Remove forward lift actuator cotter and clevis pins and set hardware aside. Cut zip tie and disconnect lift actuator from wire harness.

NOTE: Cylindrical Scrub Head Only: Remove debris tray from rear of scrub head to allow for additional clearance.



6. Lower floor jack supporting rear squeegee and remove floor jack.
7. Remove squeegee adjustment rod mounting hardware (2) and set rod and hardware aside.

NOTE: Remove caster wheels to further lower the lift mechanism and allow for additional clearance.

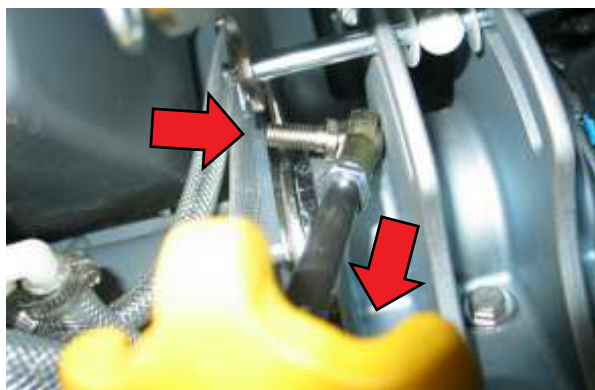

8. Allow lift mechanism to pivot downward to release some of the spring tension and provide clearance for clevis pin removal. Slide the clevis pin out and set spring and hardware aside.



9. Remove lift actuator cotter and clevis pins. Note hardware orientation for re-assembly.

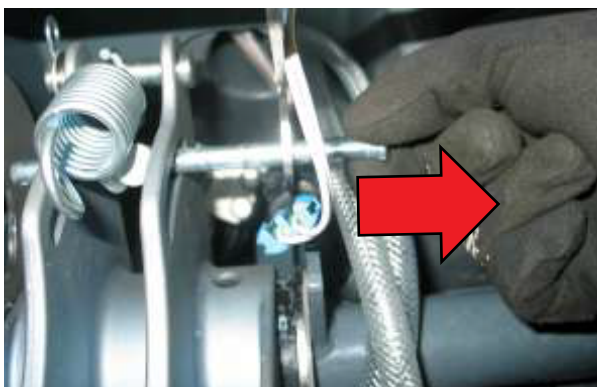

10. Remove lift actuator from space behind scrub head.



INSTALLING REAR SQUEEGEE LIFT ACTUATOR

1. Connect new lift actuator to wire harness.
2. Key On, Squeegee/Vacuum On and wait for actuator to extend completely and then turn key Off.



3. Remainder of installation is reverse of removal.

NOTE: Use a pry bar to stretch the coil spring while inserting the clevis pin through the lift mechanism.

SERVICE

SIDE BRUSH LIFT ACTUATOR

REMOVING SIDE BRUSH LIFT ACTUATOR

FOR SAFETY: Before leaving or servicing machine, stop on level surface, turn off machine and remove key.

NOTE: The side brush lift mechanism is under spring tension when in the raised/retracted position.

1. Proceed to step 2 if the actuator failed in the extended/ lowered position. It is difficult to access the side brush lift mechanism if the actuator fails in the raised (Retracted) position. Use a pry bar to release the rod-end from the ball stud as shown below. Replace the rod-end assembly after this is done.

NOTE: Using a pry bar to separate the ball stud from the rod end will damage the rod end assembly. The rod end must be replaced if this is done.

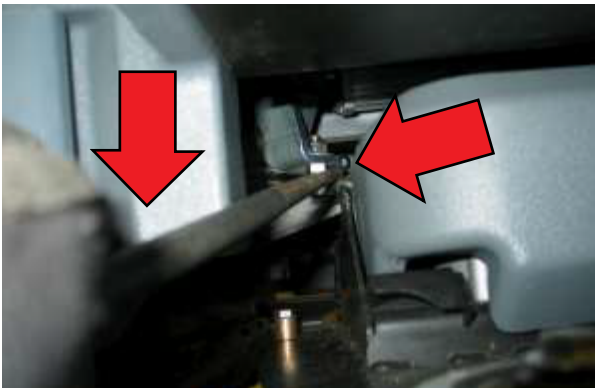

2. Remove actuator pivot bracket mounting bolt (1).



3. Remove actuator mounting clevis (2) and cotter (2) pins.

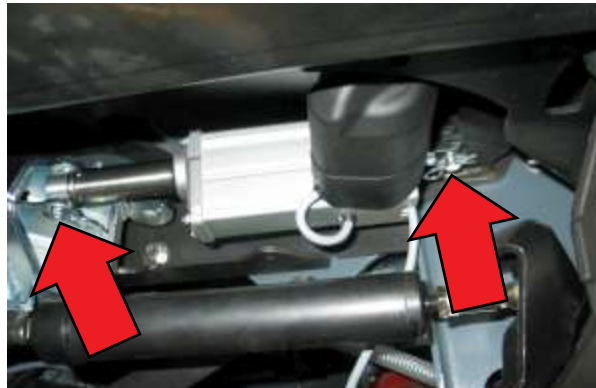

4. Cut zip tie securing actuator connector to wire harness and disconnect actuator from wire harness.
5. Remove lift actuator.



INSTALLING SIDE BRUSH LIFT ACTUATOR

FOR SAFETY: Before leaving or servicing machine, stop on level surface, turn off machine and remove key.

NOTE: The side brush spring tube assembly must be adjusted following the installation of the lift actuator or machine damage will occur.

1. Installation is the reverse of removal.

TIP: Remove the RH headlight assembly to access the pin insertion cutout of the main frame. Use a needle nose pliers to drop the clevis pin in from above.

ADJUSTING SIDE BRUSH SPRING TUBE ASSEMBLY

FOR SAFETY: Before leaving or servicing machine, stop on level surface, turn off machine and remove key.

NOTE: Jack the front of the machine to allow improved access to the side brush spring tube assembly.

1. Key On. Allow the side brush to lift/retract completely and then turn the key off.



2. Inspect the adjustment gap between the side brush cover and the inside mounting bolt as shown below. The gap should be approximately 0.25in (6.4mm) while applying 2 lbs(9 N) of downward force on the cover. *This is necessary because light spring tension on the lift mechanism may close the gap.*

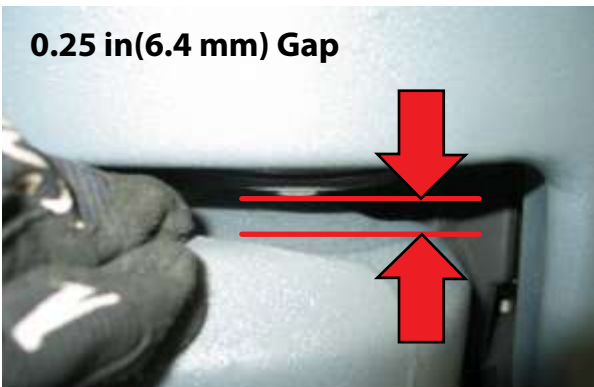

NOTE: Failure to adjust this gap properly could result in actuator failure.

3. Key On, 1-STEP scrub On, side brush switch On. Allow the side brush to lower completely and then turn the key off.



4. Loosen forward jam nut on side brush spring tube assembly.



5. Turn the spring tube assembly CW to shorten the tube, thereby opening the adjustment gap in Step 2. Turn the spring tube assembly CCW to lengthen the tube, thereby closing the adjustment gap in Step 2. Cycle the side brush up down to check the gap.

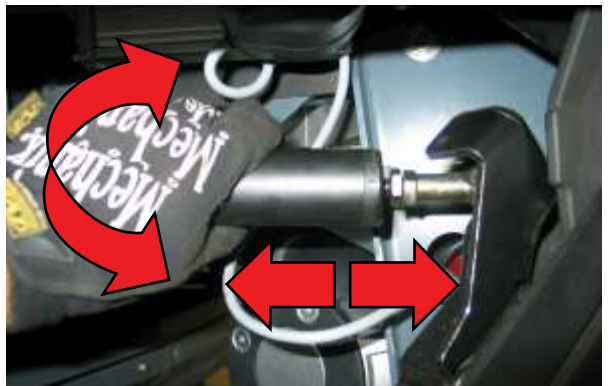

6. Tighten the jam nut.

SERVICE

SIDE BRUSH MOTOR

REMOVING SIDE BRUSH MOTOR

FOR SAFETY: Before leaving or servicing machine, stop on level surface.

1. Jack front of machine and support using jack stands or support blocks.
2. Remove side brush and side brush squeegee assembly and set aside.
3. Remove side brush hub mounting bolt (1) and hub and set aside.



4. Remove motor mounting hardware (4) and set aside.



5. Key On, 1-STEP Scrub On, side brush On and allow side brush motor to lower completely. Turn Key Off.
6. Remove side brush cover mounting hardware (2) and set aside.



7. Cut zip tie securing solution hose and wire harness to side brush cover and set cover aside.
8. Disconnect side brush motor from wire harness and remove side brush motor.



INSTALLING SIDE BRUSH MOTOR

1. Installation is the reverse of removal. .

NOTE: Apply anti-seize to side brush motor shaft and motor/hub mounting hardware.

**REPLACING CARBON BRUSHES**

1. Remove carbon brush caps (4).



2. Remove carbon brushes (4).



SERVICE

MAIN BRUSH LIFT ACTUATOR

REMOVING MAIN BRUSH LIFT ACTUATOR

FOR SAFETY: Before leaving or servicing machine, stop on level surface, turn off machine and remove key.

1. Key Off. Disconnect batteries.
2. Jack front of machine and support using jack stands or support blocks.



3. Remove scrub brushes.
4. Support scrub head using support blocks.
5. Remove actuator lower mounting pin from scrub head.

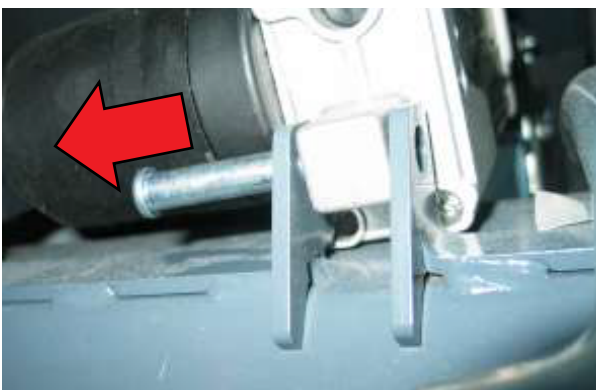

6. Carefully remove scrub head support blocks and lower scrub head to the floor.

7. Cut zip tie securing actuator wire harness and disconnect actuator from wire harness.
8. Remove actuator upper mounting pin from lift mechanism.



9. Remove lift actuator.



INSTALLING MAIN BRUSH LIFT ACTUATOR

1. Key Off. Disconnect batteries.
2. Installation is the reverse of removal.

NOTE: This actuator does not require an installation adjustment. Turn the actuator tube manually to align the mounting holes and insert clevis and cotter pins.

MAIN SCRUB HEAD

REMOVING MAIN SCRUB HEAD

FOR SAFETY: Before leaving or servicing machine, stop on level surface, turn off machine and remove key.

1. Drain solution tank and turn key Off.
2. Remove scrub brushes and debris tray (cylindrical only).
3. Lift front of machine as shown below. Be sure to use wheel chocks and jack stands or support blocks.



4. Enter Manual Mode and lower scrub head completely (See Manual Mode in the Troubleshooting section of this manual). Turn key Off immediately when head touches the floor.



5. Remove lift actuator cotter and clevis pins from scrub head frame and set hardware aside.

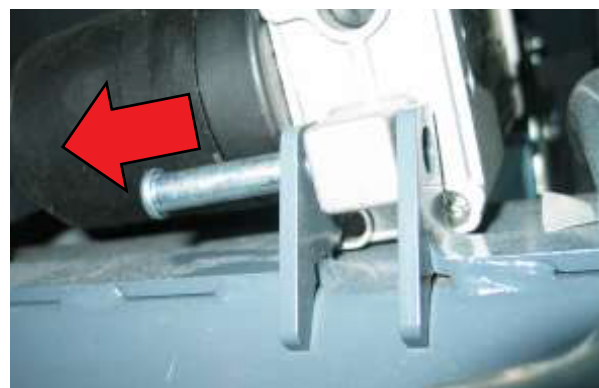

6. Remove front scrub head linkage bolts (2) and set hardware aside.



7. Remove rear scrub head linkage bolts (2) and set hardware aside.



SERVICE

8. Remove upper lift actuator cotter and clevis pins.
Disconnect lift actuator from wire harness. Remove lift actuator and set aside.



9. Disconnect water hoses from scrub head.
10. Disconnect water valve and brush motors from wire harness.
11. Remove the scrub head assembly.

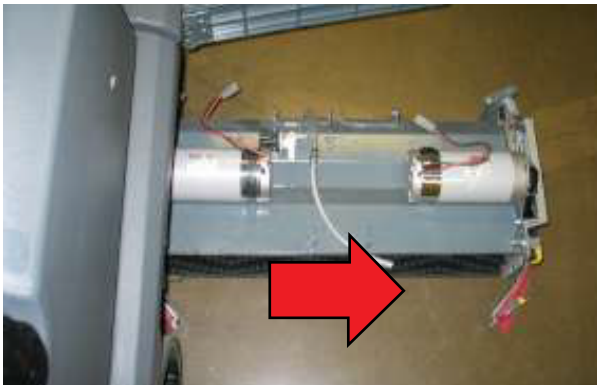

INSTALLING MAIN SCRUB HEAD

1. Installation is the reverse of removal.

MAIN SCRUB BRUSH MOTOR (CYLINDRICAL)

REMOVING MAIN BRUSH MOTOR

FOR SAFETY: Before leaving or servicing machine, stop on level surface, turn off machine and remove key.

FOR SAFETY: When servicing machine, jack machine up at designated locations only. Block machine up with jack stands.

1. Jack front of machine and support using jack stands or support blocks.



2. Remove scrub brushes.
3. Enter Manual Mode and lower scrub head completely (See Manual Mode in the Troubleshooting section of this manual). Turn key Off immediately when head touches the floor.



4. Remove belt cover bolts (2) and set cover and hardware aside.



4. Remove belt by turning pulleys and applying outward pressure on the belt.

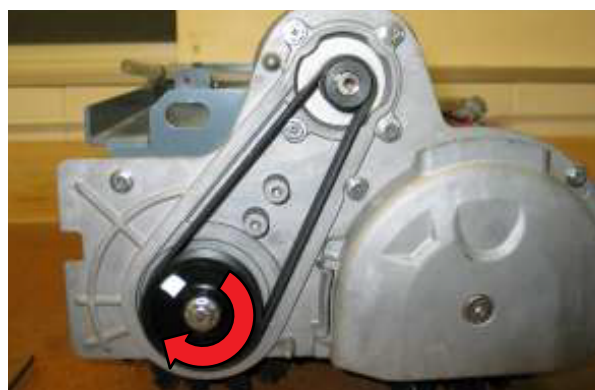

5. Loosen set screws (2) securing the drive pulley onto the motor shaft and remove belt drive pulley.
6. Remove motor mounting hardware (4) and set aside.



SERVICE

7. Disconnect motor from wire harness and remove motor.



INSTALLING MAIN BRUSH MOTOR

1. Installation is reverse of removal.

REPLACING CARBON BRUSHES

1. Release the motor band clamp and set aside.



2. Remove carbon brush mounting screws (4) and set aside.



3. Release spring tabs using a small screwdriver.



4. Remove carbon brushes.



5. Installation is the reverse of removal.

INSTRUMENT PANEL

REMOVING INSTRUMENT PANEL

FOR SAFETY: When servicing machine, disconnect battery connections before working on machine.

1. Key Off. Disconnect battery.
2. Remove front access panel.



3. Cut zip tie securing instrument panel wire harness connections.
4. Disconnect instrument panel connector.



5. Loosen set screws (2) securing instrument panel mounting tube.



6. Remove instrument panel assembly.



INSTALLING INSTRUMENT PANEL

1. Installation is the reverse of removal.
2. See CONFIGURATION MODE in the troubleshooting section of this manual to configure the new instrument panel.

SERVICE

LOGIC BOARD REPLACEMENT

REMOVING LOGIC BOARD

FOR SAFETY: When servicing machine, disconnect battery connections before working on machine.

1. Key Off. Disconnect batteries.
2. Lift seat.
3. Remove side access panel mounting bolt (1).



4. Remove side access panel and set aside.



5. Remove circuit board cover mounting hardware (6).



6. Attach a wrist static strap tool to a bare metal frame surface.



7. Disconnect logic board connectors and cables.



NOTE: Always use two wrenches when securing the power supply terminals or damage to the circuit board will occur. Also, make sure the power supply terminals are secured on the new board before installation. The torque specification is 52 in-lbs (6 Nm).

8. Remove logic board mounting screws (2).

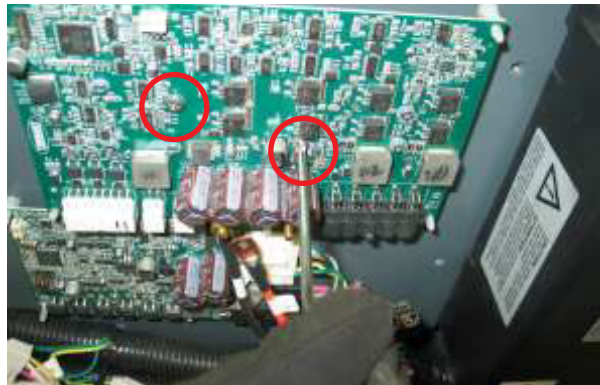

9. Carefully squeeze the plastic standoffs and remove the logic board.

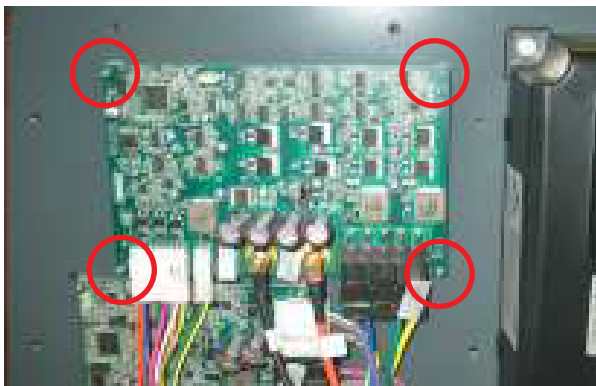

INSTALLING LOGIC BOARD

FOR SAFETY: When servicing machine, disconnect battery connections before working on machine.

1. Attach a wrist static strap tool to a bare metal frame surface.



2. Remainder of installation is the reverse of removal.

NOTE: Always use two wrenches when securing the power supply terminals or damage to the circuit board will occur. Also, make sure the power supply terminals are secured on the new board before installation. The torque specification 52 in-lbs (6 Nm).

SERVICE

STEERING WHEEL TIMING

FOR SAFETY: Before leaving or servicing machine, stop on level surface, turn off machine and remove key.

1. Key Off. Disconnect batteries.
2. Remove front access panel.



3. Loosen steering shaft hardware.



4. Lift steering u-joint off splined shaft.

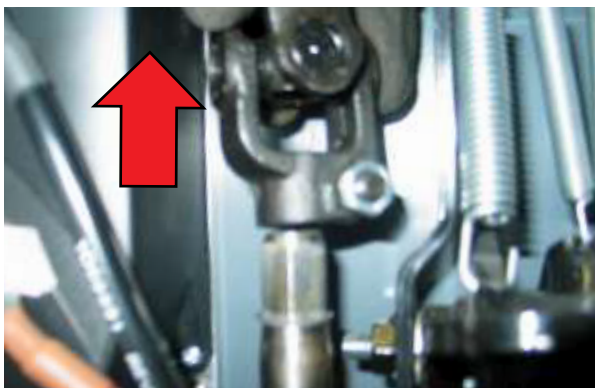

5. Align the front drive tire with the centerline of the machine.

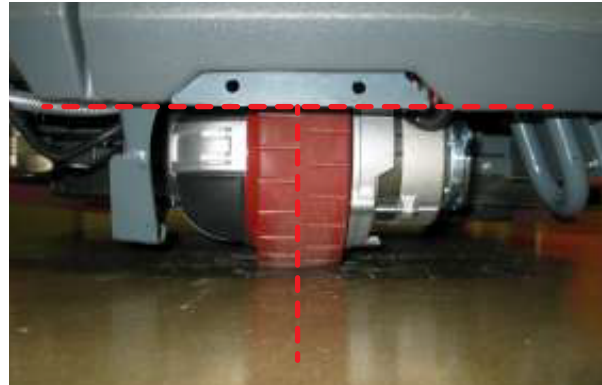

6. Orientate the steering wheel as shown below.



7. Carefully reinstall the steering u-joint onto the splined steering shaft without changing the orientation of the steering wheel or drive assembly.

NOTE: Check for rotational interference between the hardware and the adjacent pedal assembly. If necessary, raise the steering u-joint enough to clear the pedal assembly.



WHEEL DRIVE ASSEMBLY

REMOVING WHEEL DRIVE ASSEMBLY

FOR SAFETY: Before leaving or servicing machine, stop on level surface, turn off machine and remove key.

FOR SAFETY: When servicing machine, jack machine up at designated locations only. Block machine up with jack stands.

FOR SAFETY: When servicing machine, disconnect battery connection before working on machine.

1. Key Off. Disconnect batteries.
2. Jack front of machine and support using jack stands or support blocks and chock rear tires.



3. Remove steering plate mounting hardware (4).

NOTE: Drive assembly will not release. The steering plate is secured to the main frame with (3) additional fasteners from the top (see Step 5).

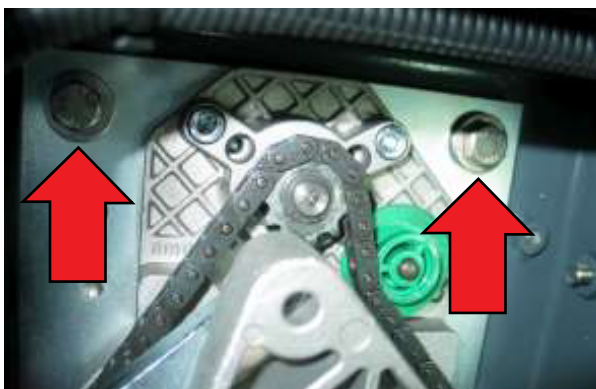

4. Jack front of machine and remove jack stands or support blocks so wheel drive assembly is supported by the floor.



5. Remove front access panel and remove steering plate mounting hardware (3).

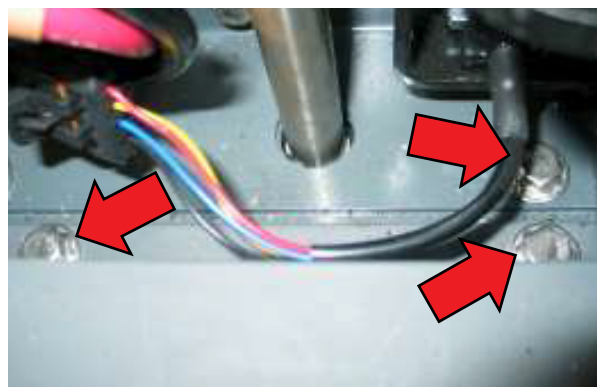

6. Loosen steering u-joint hardware and lift u-joint off splined steering shaft.

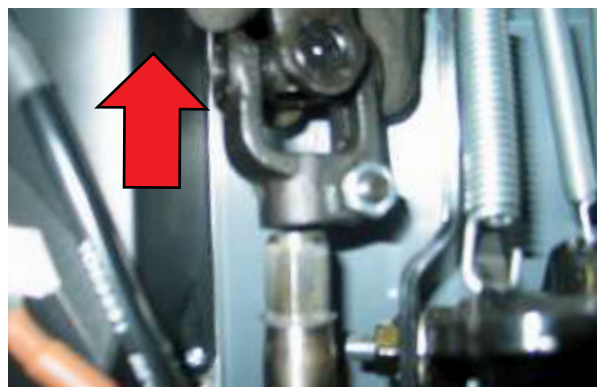

SERVICE

7. Carefully jack front of machine until the drive wheel assembly can be removed from the side of the machine.



8. Remove propel cable clamp mounting hardware (2).



9. Remove terminal cover and disconnect cables from drive assembly.



INSTALLING WHEEL DRIVE ASSEMBLY

FOR SAFETY: Before leaving or servicing machine, stop on level surface, turn off machine and remove key.

FOR SAFETY: When servicing machine, jack machine up at designated locations only. Block machine up with jack stands.

FOR SAFETY: When servicing machine, disconnect battery connection before working on machine.

1. Installation is the reverse of removal.
2. See STEERING WHEEL TIMING in the SERVICE section of this manual.

REPLACING THE DRIVE TIRE

1. Remove (4) flat head screws.

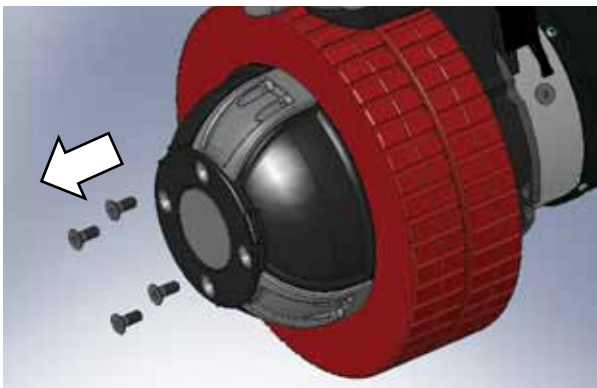

2. Use (4) M10-1.5 x 70 (Class 12.9) socket head bolts to mechanically press off the tire. Tighten the bolts evenly in a diagonal pattern. REMOVE THE BOLTS AFTER THIS STEP IS COMPLETE.



3. Remove (6) socket head screws.

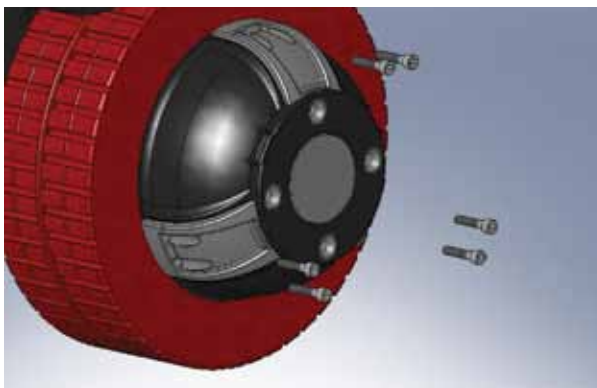

4. Remove aluminum hub and plastic cover.

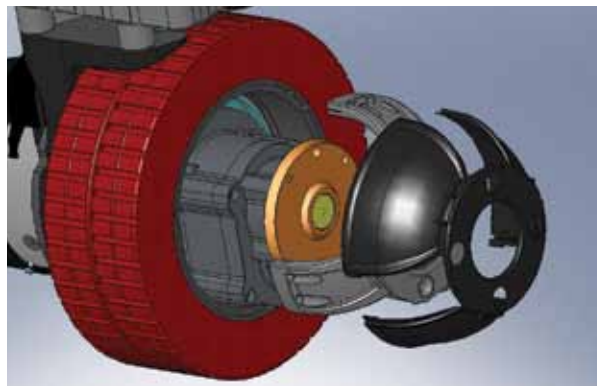

5. Replace the drive tire.

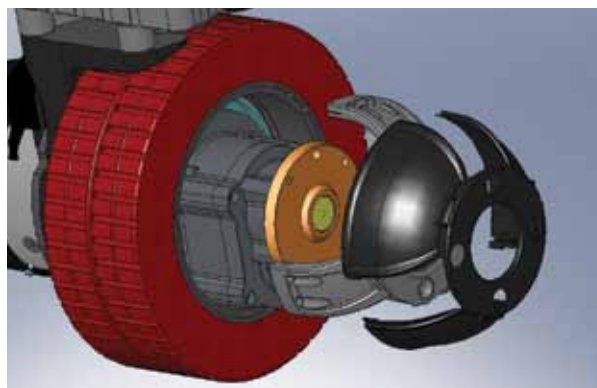

6. Installation is the reverse of removal. Use a plastic mallet to reassemble the wheel drive assembly. Torque M6 hardware to 15Nm (11 ft-lbs) and M8 hardware to 22 Nm (16 ft-lbs).

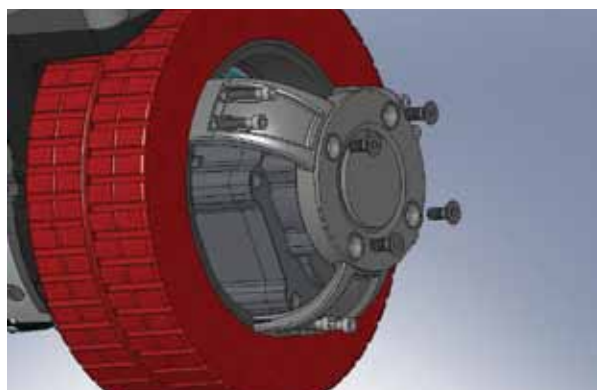

SERVICE

VACUUM FAN ASSEMBLY

REMOVING VACUUM FAN ASSEMBLY

FOR SAFETY: Before leaving or servicing machine, stop on level surface, turn off machine and remove key.

1. Key Off.
2. Disconnect hose from rear squeegee and move spray nozzle away from the vacuum fan access cover.



3. Remove hardware (1) and vacuum fan access cover and set aside.



4. Remove sound insulation and set aside.

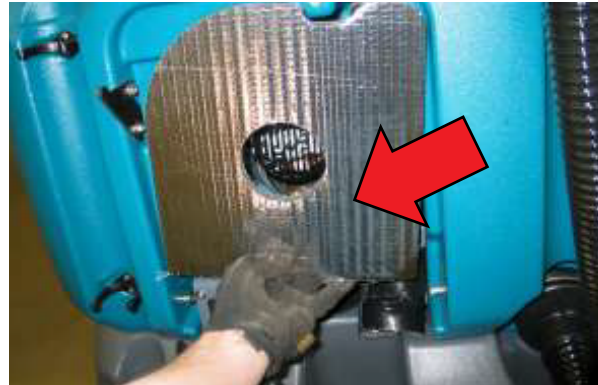

5. Cut zip tie and disconnect vacuum fan from wire harness.



6. Remove vacuum fan mounting hardware (5).



7. Carefully pry on the vacuum fan mounting flange to break the silicone seal. Remove the vacuum fan assembly and set aside.



8. Remove any residual silicone from the tank mounting surface in preparation for the replacement vacuum fan assembly.



9. Draw a line across the vacuum fan assembly and the mounting flange as an orientation indicator for re-assembly.



10. Loosen the clamp and remove mounting flange from vacuum fan assembly.



INSTALLING VACUUM FAN ASSEMBLY

NOTE: The worm-drive clamp must be orientated on the mounting flange to fit into a tank recess during reassembly.

1. Secure mounting flange to new vacuum fan assembly and apply 1/4" bead of silicone as shown below.



2. Remainder of installation is reverse of removal.

SERVICE

TESTING TANK LEVEL SENSORS

FOR SAFETY: Before leaving or servicing machine, stop on level surface.

1. Test the resistance of the recovery tank level sensor using an ohmmeter as shown below. The tank level switch should test as "O.L." or open.

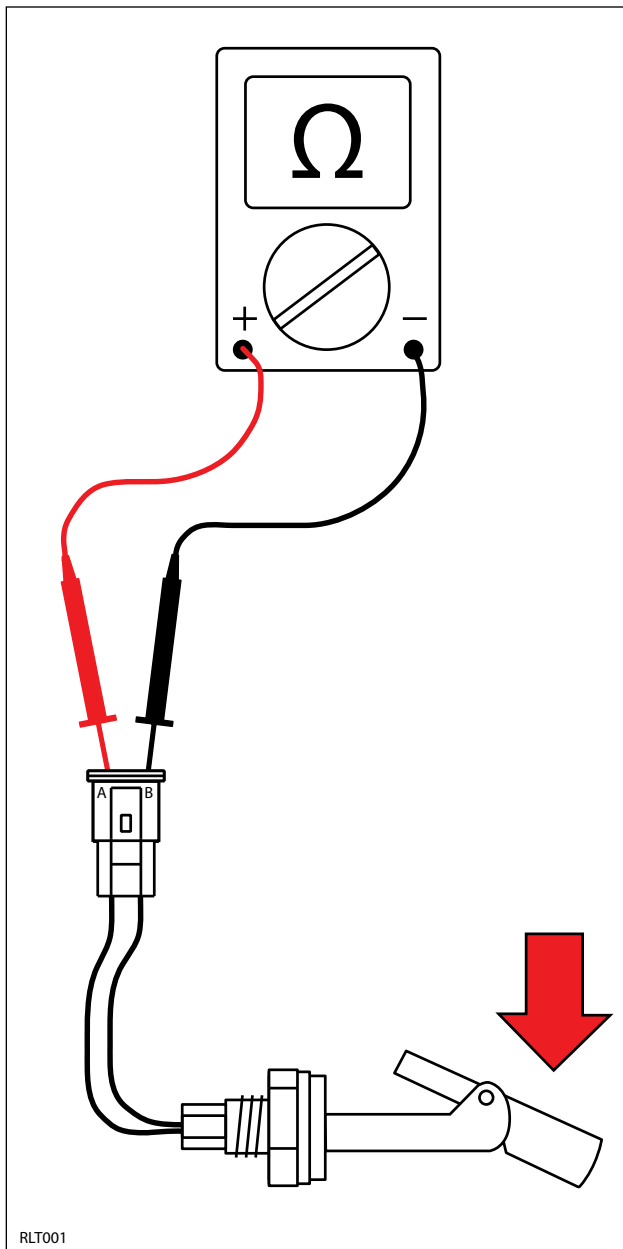

2. Test the resistance of the recovery tank level sensor using an ohmmeter as shown below. The tank level switch should test at 0-1 ohms or closed.

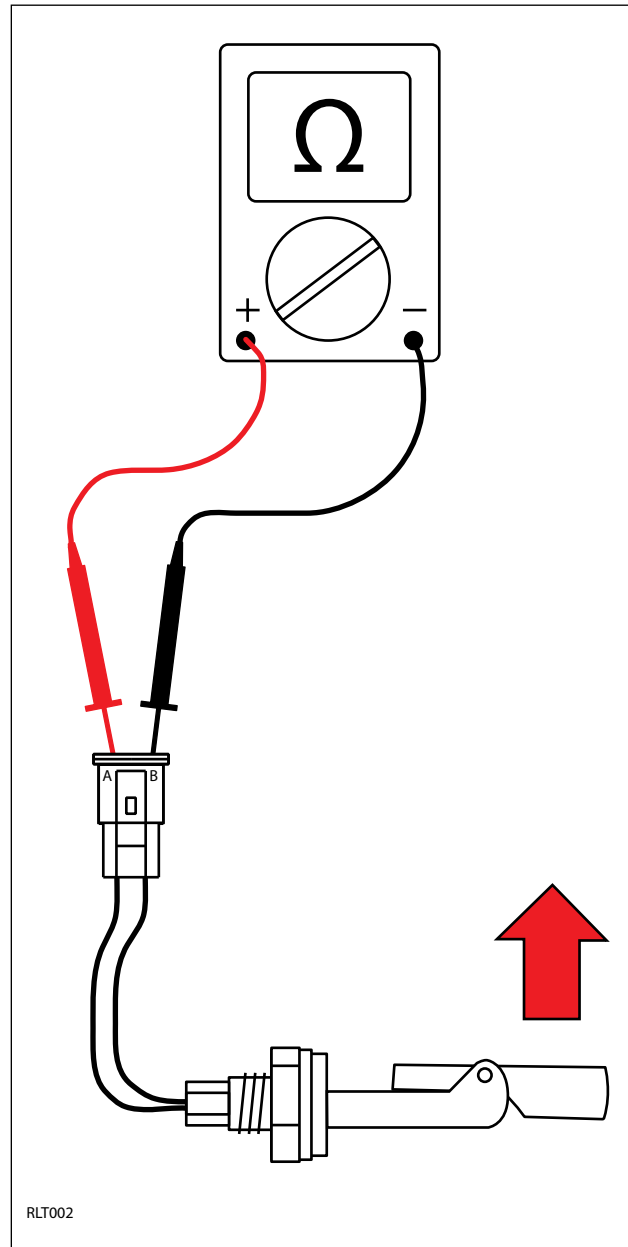

- The solution and recovery tank full sensor conditions are also viewable in Input Display Mode. See “Input Display Mode” in the TROUBLESHOOTING section of this manual.

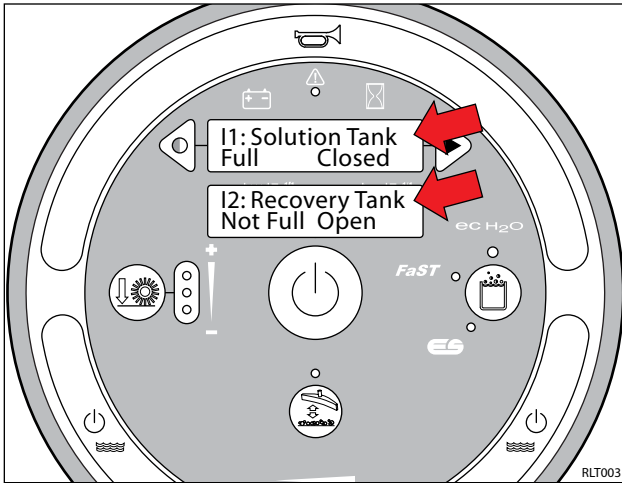

SERVICE

TESTING PARKING BRAKE, ELECTROMAGNETIC

FOR SAFETY: Before leaving or servicing machine, stop on level surface, turn off machine and remove key.

FOR SAFETY: When servicing machine, disconnect battery connection before working on machine.

1. Key Off. Remove brake cover mounting screws and set cover and hardware aside.

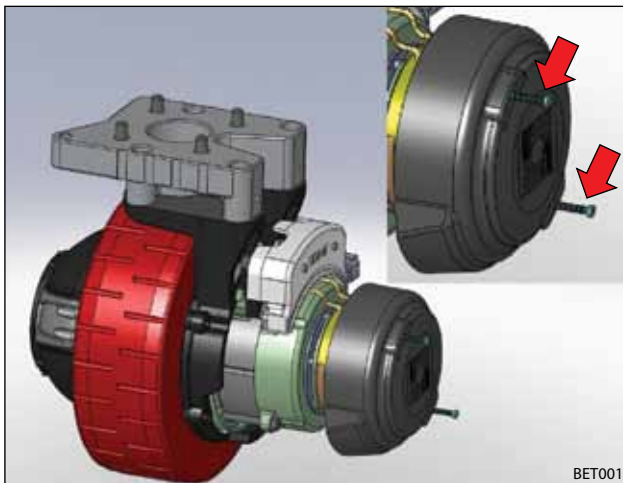

2. Key Off. Remove brake assembly mounting screws and set aside. Leave brake assembly on the splined shaft.

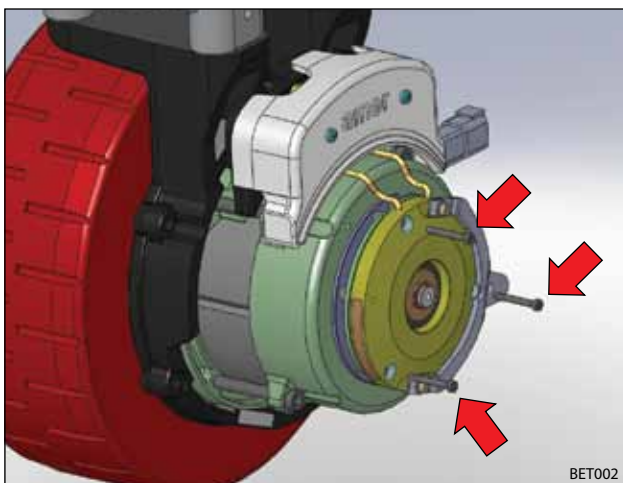

3. Key Off. The brake applies when the key switch is turned off. Attempt to manually rotate the brake assembly on the splined shaft as shown below. The brake assembly SHOULD NOT rotate freely on the splined shaft when the wheel is in a fixed position.

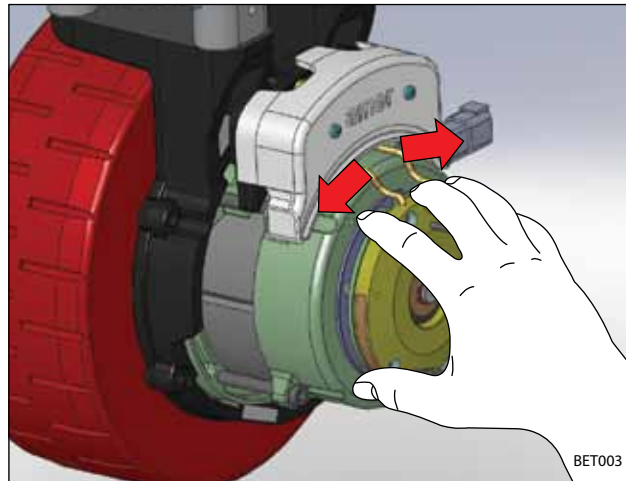

4. Disconnect brake wires and slide the brake assembly off the splined shaft

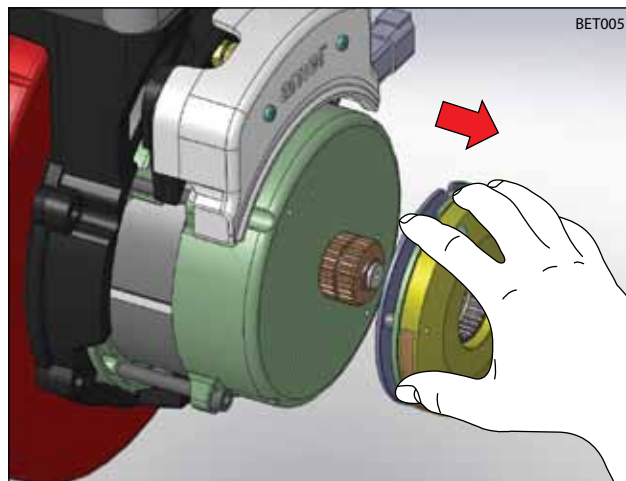

- Remove three flat head screws to disassemble the brake assembly.

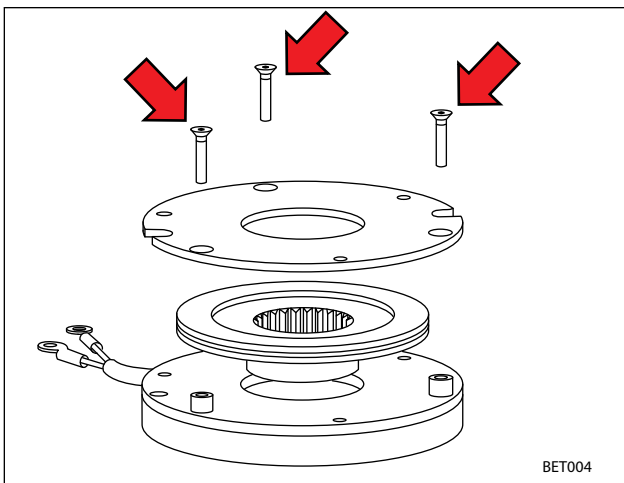

- Reassemble the brake assembly and slide it back onto the splined shaft.

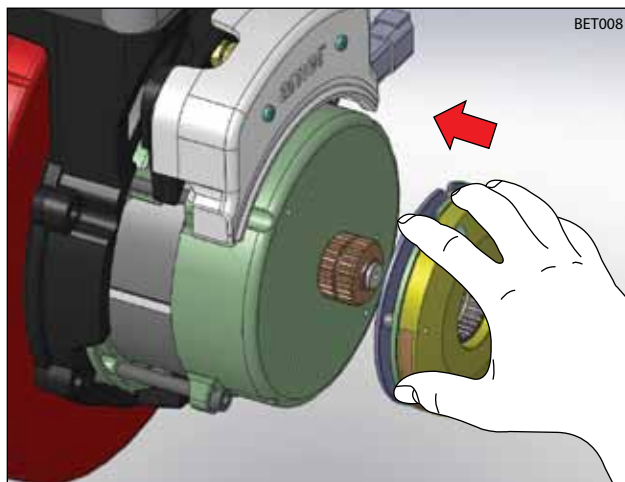

- Measure the thickness of the brake rotor using a vernier caliper. Replace the rotor if it is less than 4.4mm (0.17in) thickness.

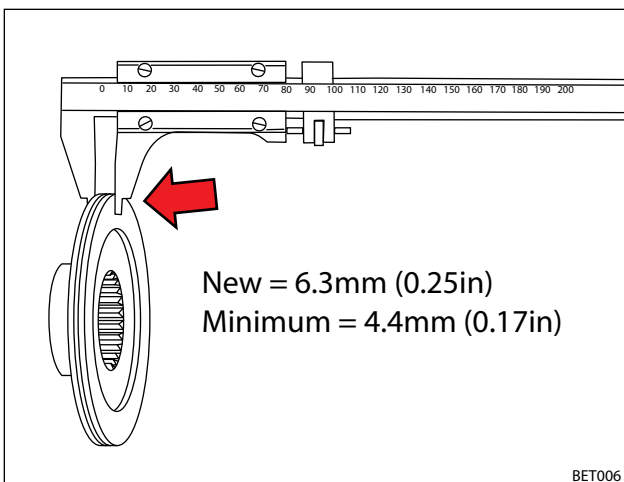

- Remove connection box cover screws and set cover aside.

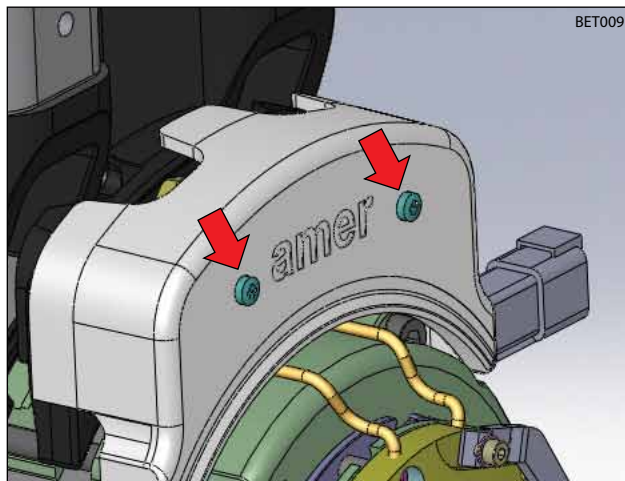

SERVICE

9. Remove brake wires from the B1 and B2 terminals in the connection box.

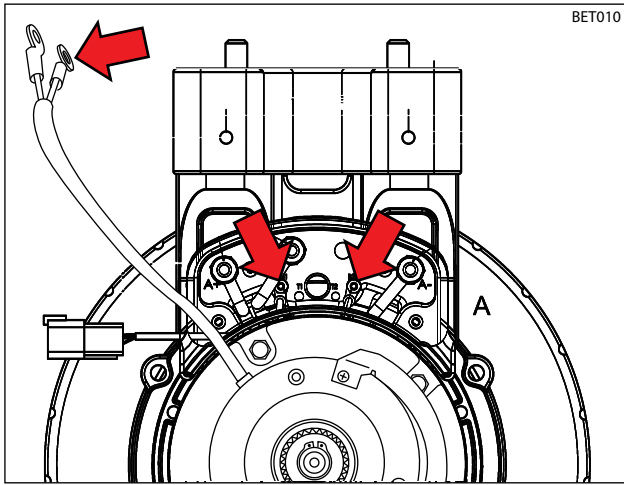

10. Test the resistance of the brake coil using an ohmmeter as shown below. The resistance should be approximately 50-60 Ohms.

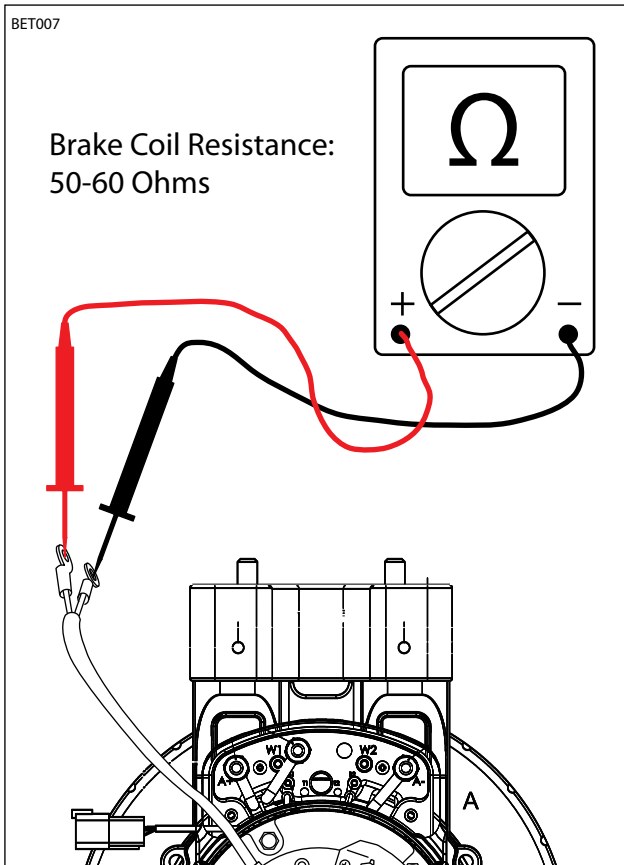

11. Apply battery voltage to the brake assembly using fuse-protected jumper leads as shown below. The brake energizes to release. Attempt to manually rotate the brake assembly while battery voltage is applied. Replace the brake assembly if it DOES NOT rotate freely on the splined shaft.

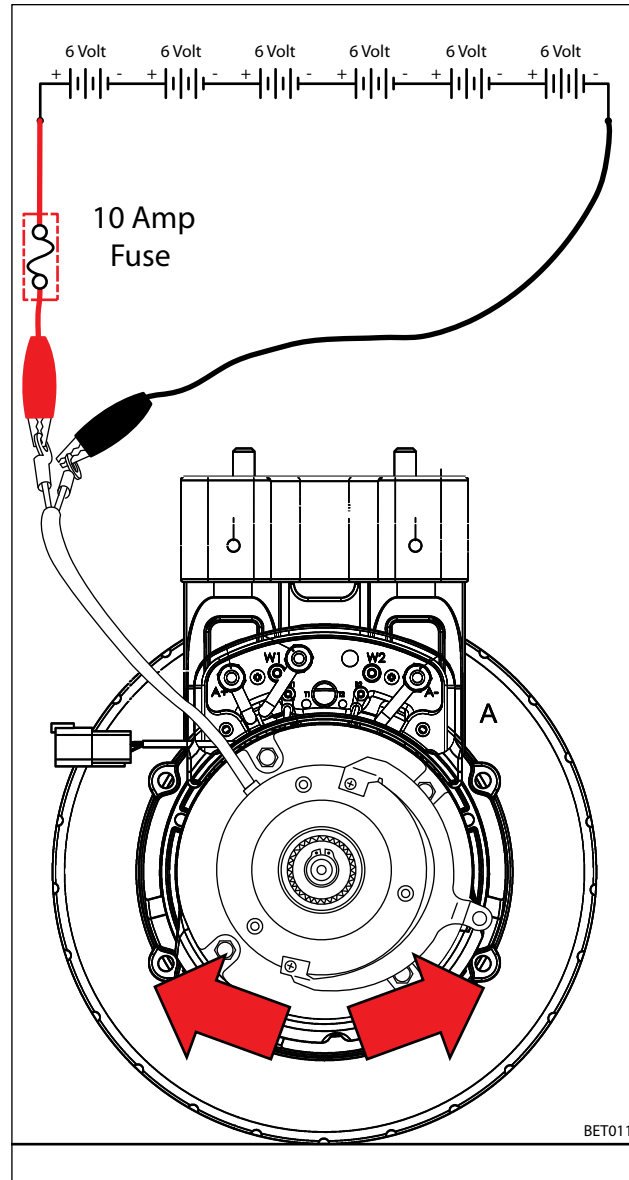

12. Clean and inspect the brake assembly as required.

TESTING PROPEL MOTOR

FOR SAFETY: Before leaving or servicing machine, stop on level surface, turn off machine and remove key.

FOR SAFETY: When servicing machine, disconnect battery connection before working on machine.

1. Key Off. Remove terminal box cover screws and set cover aside.

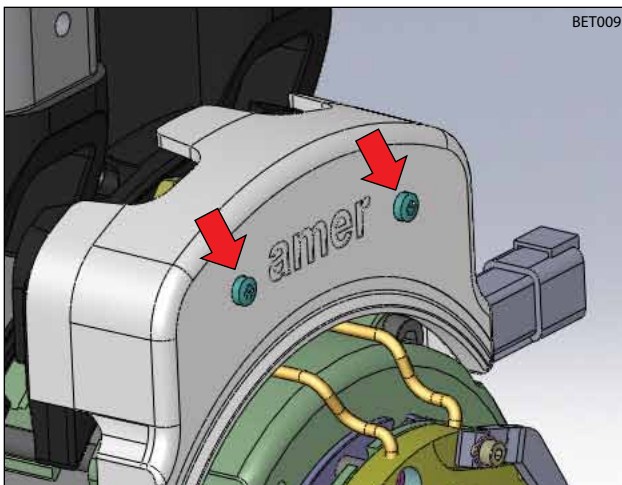

2. Disconnect U, V, and W cables from W1, A-, and A+ terminals (respectively).

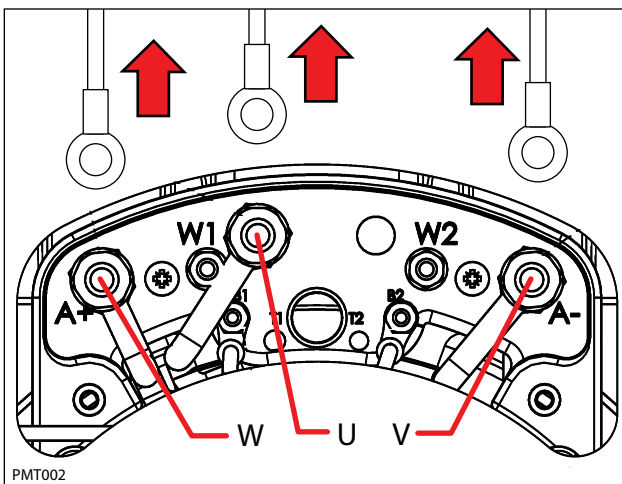

3. Test the resistance of all three motor windings using an ohmmeter as shown below. The resistances of each winding should be within 5% of each other. An open or shorted winding indicates a faulty motor.

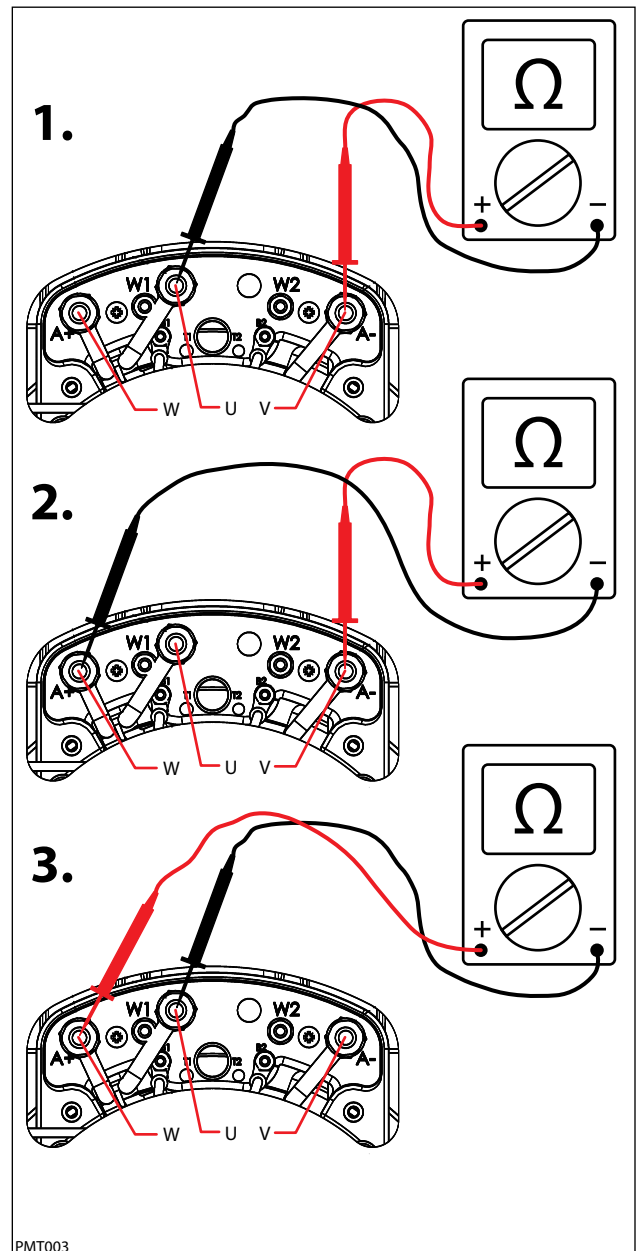

SERVICE

4. Test the resistance between all three motor terminals and the motor case as shown below. The ohmmeter should read "O.L." or open. A shorted winding indicates a faulty motor.

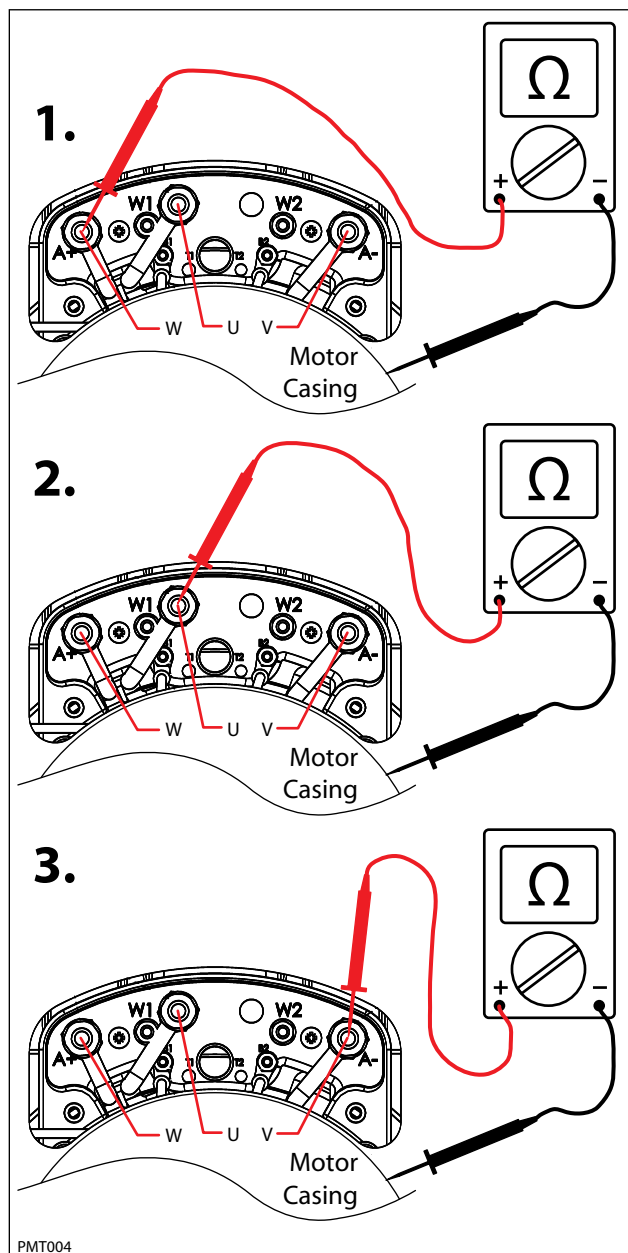

5. The motor encoder and temperature sender are non-serviceable components of the drive motor. The motor encoder senses rotor position, speed, and direction. The encoder is integrated into an internal roller bearing assembly. See "Curtis 1232 LED Faults" in the TROUBLESHOOTING section for encoder related faults.

The temperature sender senses the propel motor temperature. Test the resistance of the temperature sender using an ohmmeter and then compare the values to the chart below. Replace the motor assembly if the resistance values are out of the specified range.

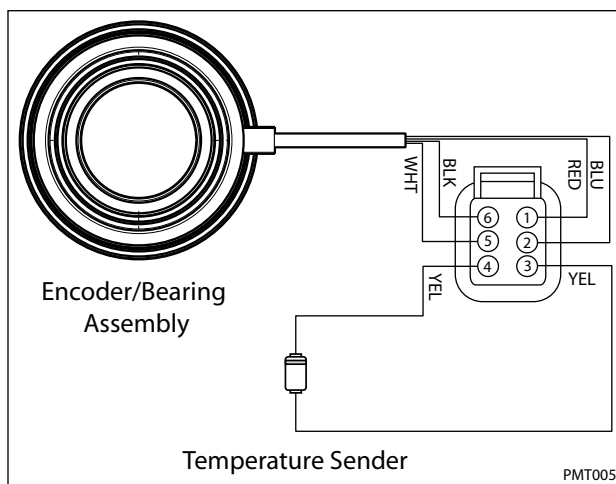

TEMPERATURE		RESISTANCE (Ω)		
($^{\circ}$ C)	($^{\circ}$ F)	MIN.	TYP.	MAX
-30	-22	362	381	368
0	32	464	486	507
25	77	565	588	611
30	86	587	610	633
50	122	679	704	728
70	158	781	806	831
80	176	835	860	885
100	212	950	975	1000
110	230	1007	1036	1064

TESTING PROPEL MOTOR CABLES

FOR SAFETY: Before leaving or servicing machine, stop on level surface, turn off machine and remove key.

FOR SAFETY: When servicing machine, disconnect battery connection before working on machine.

1. Key Off. Disconnect batteries. Remove terminal box cover screws and set cover aside.

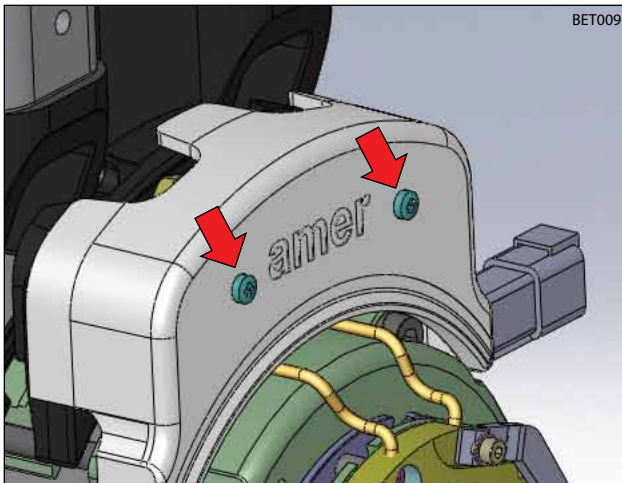

2. Disconnect U, V, and W cables from W1, A-, and A+ terminals (respectively).

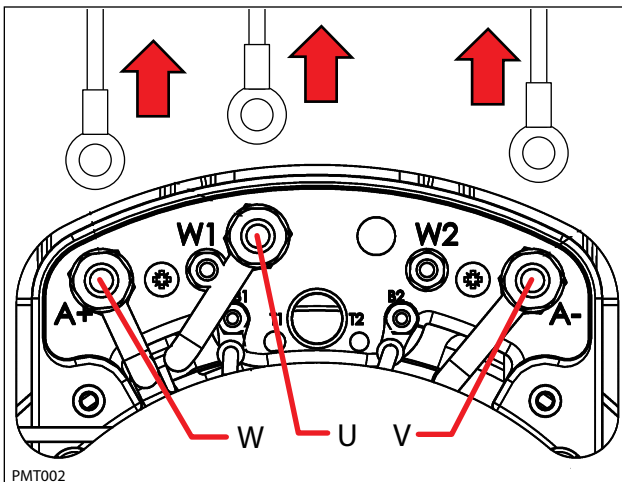

3. Disconnect U, V, and W cables from Curtis 1232 controller as shown below.

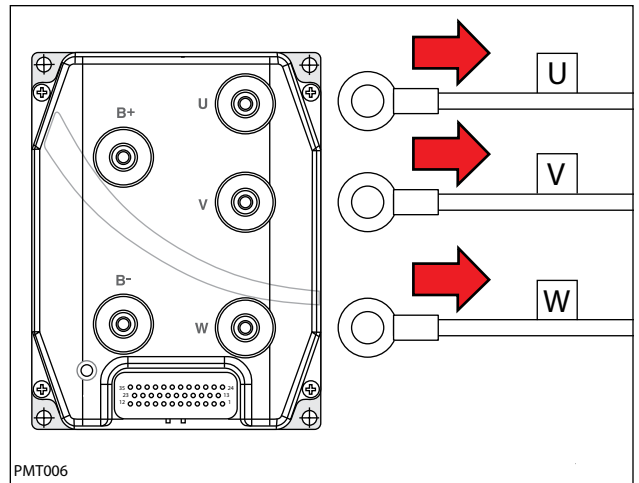

4. Reconnect battery connection and test each cable using an Ohmmeter for a short to battery + as shown below. Each cable should test as "O.L." or open to battery +. Replace shorted cable(s).

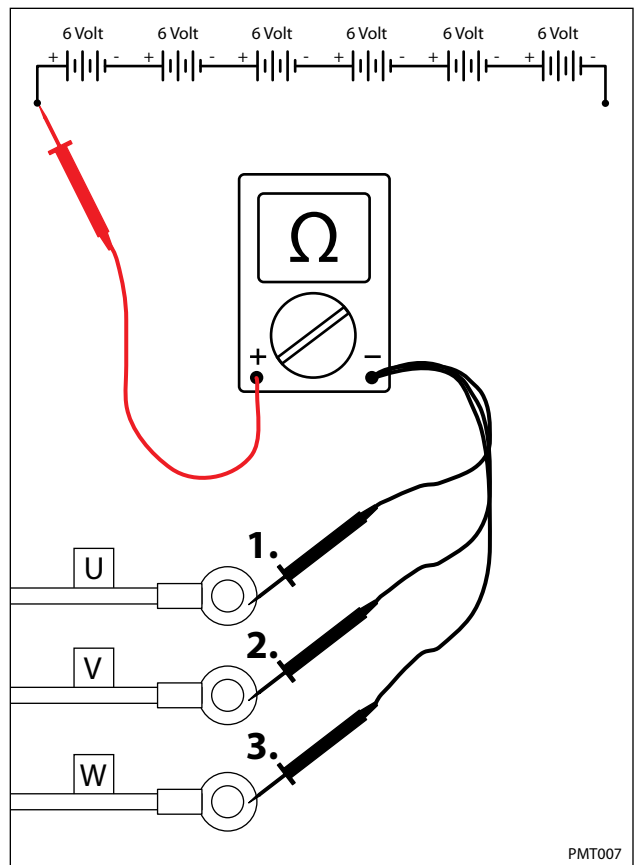

SERVICE

5. Test each cable using an ohmmeter for a short to battery - as shown below. Each cable should test as "O.L." or open to battery -. Replace shorted cable(s).

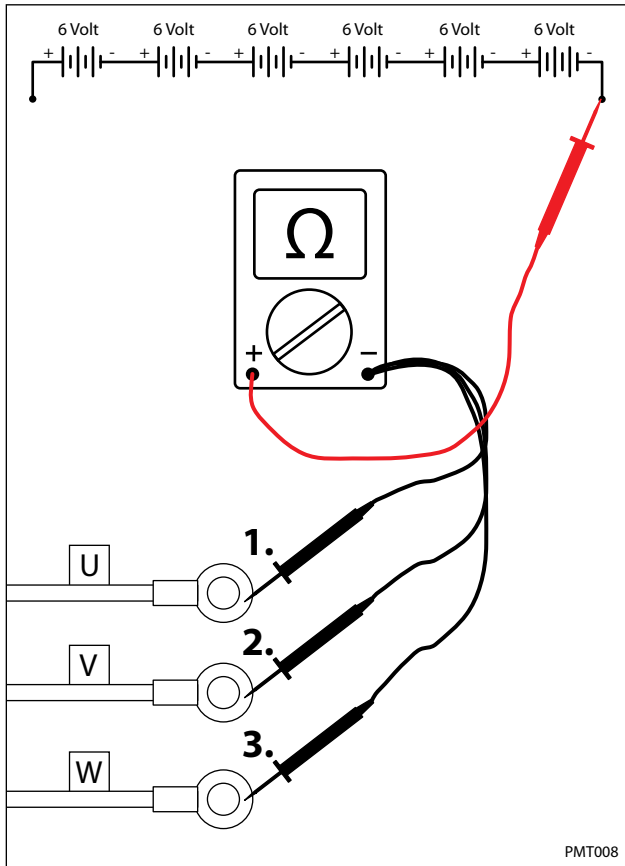

6. Test each cable using an ohmmeter for a short to chassis as shown below. Each cable should test as "O.L." or open to chassis. Replace shorted cable(s).

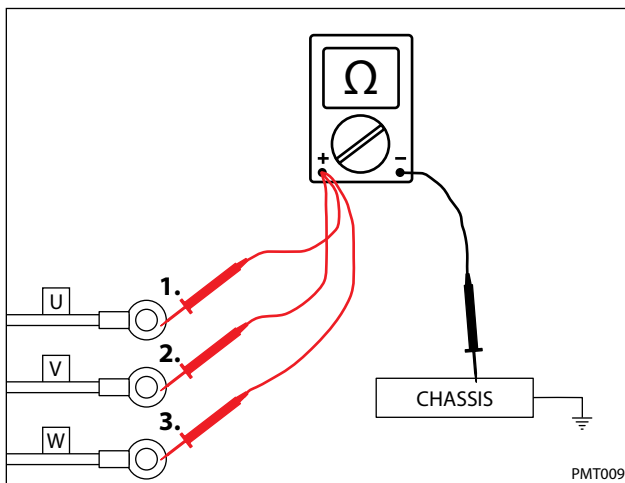

7. Test each cable using an ohmmeter for end-to-end continuity. Each cable should test between 0-1 ohm resistance. Replace open cable(s).

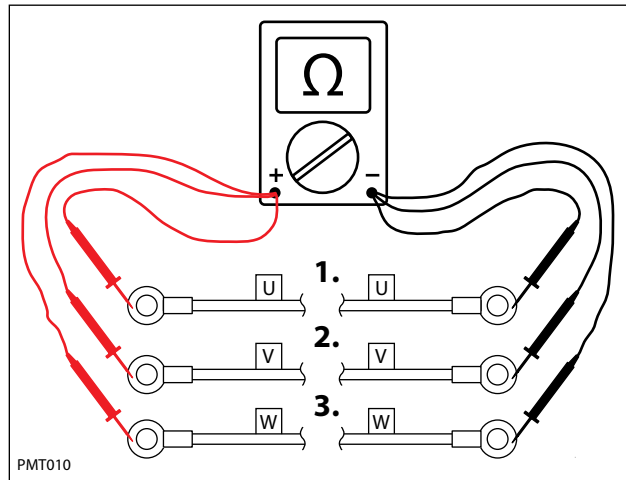

8. "Tug test" each cable (motor end) to determine if a cable is broken inside the insulation. Do not exceed 10 lbs (45 N) of force as cable damage may occur. Replace broken cables.

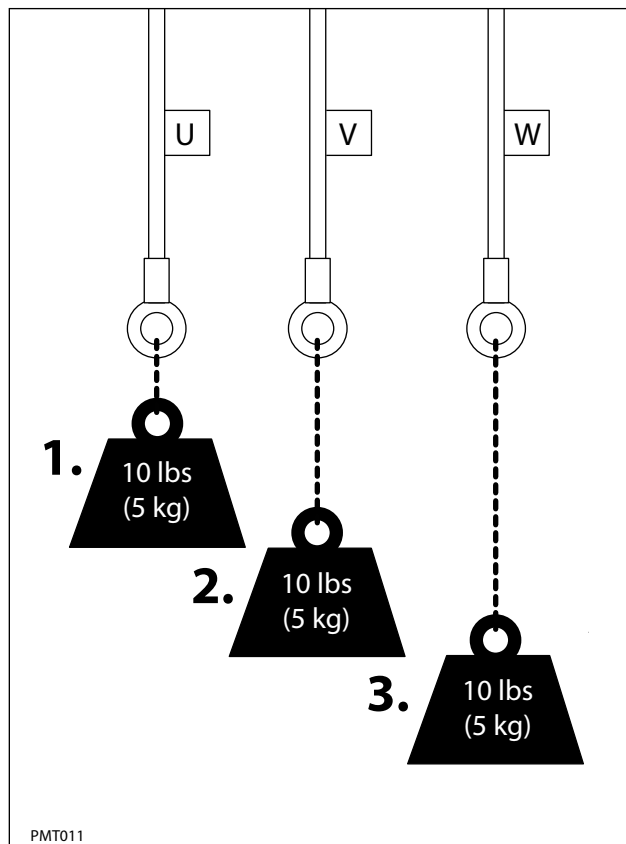

TESTING THROTTLE/BRAKE SENSOR

FOR SAFETY: Before leaving or servicing machine, stop on level surface.

FOR SAFETY: When servicing machine, jack machine up at designated locations only. Block machine up with jack stands.

FOR SAFETY: When servicing machine, avoid moving parts. Do not wear loose jackets, shirts, or sleeves when working on machine .

1. Jack machine up so front drive wheel is not touching the floor. Block machine up with jack stands.
2. The throttle and brake hall effect sensor is a component of the pedal subassembly.

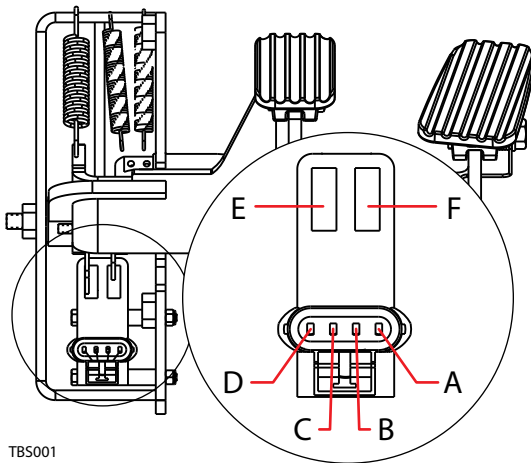

TBS001

PIN/CAVITY	NOTES	COLOR
A	POWER (BATTERY +)	RED
B	FORWARD OUTPUT (0-5Vdc)	YELLOW
C	BRAKE (0-5Vdc)	BLUE
D	GROUND (BATTERY -)	BLACK
E	GATE A	N/A
F	GATE B	N/A

3. Key On. Backprobe the power supply to the throttle/ brake sensor terminals A and D using a voltmeter as shown below. The voltmeter should display battery voltage.

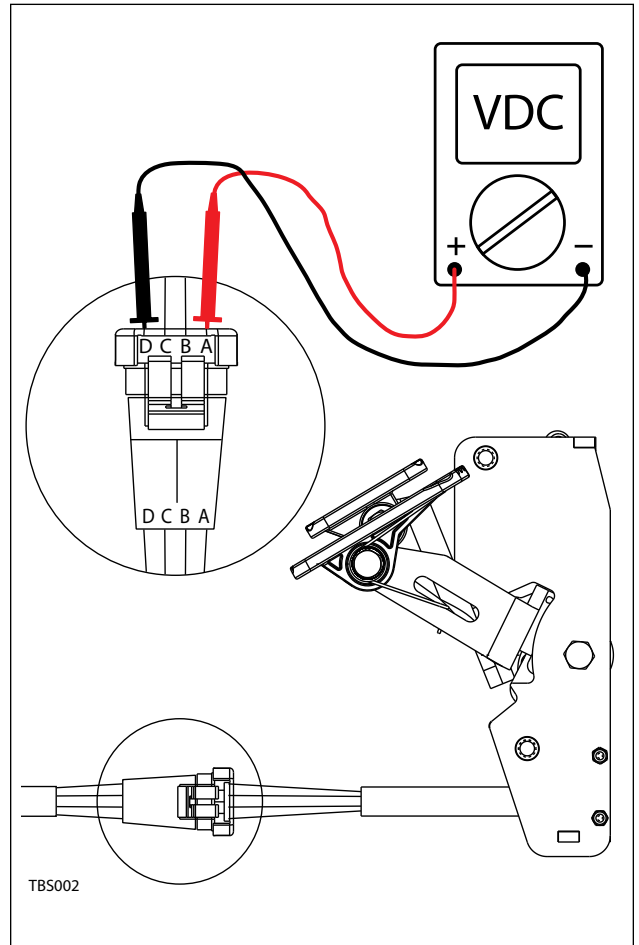

TBS002

SERVICE

4. Key On. Backprobe the throttle sensor output terminals B and D using a voltmeter as shown below. The voltmeter should display 0-5 volts proportional to 0-100% propel pedal movement.

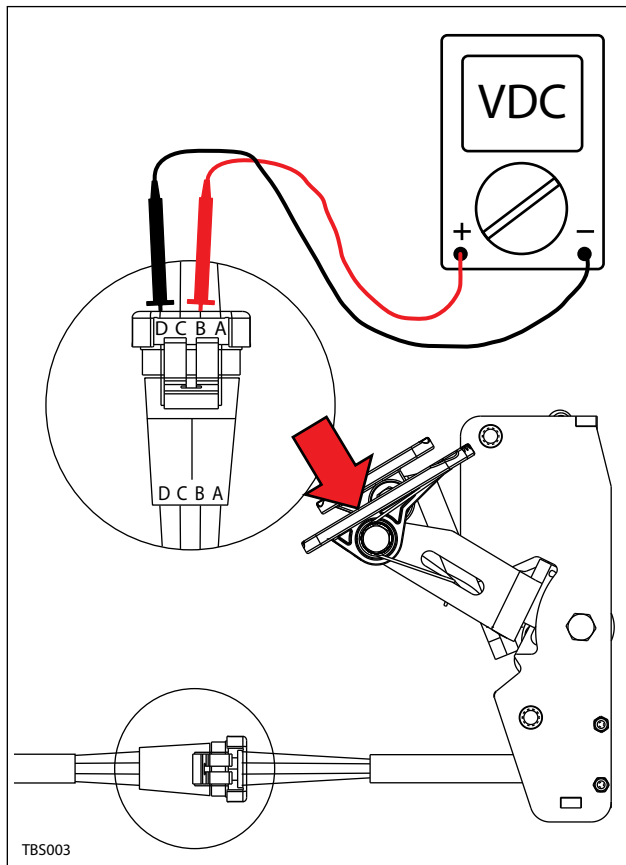

6. Key On. Backprobe the brake sensor terminals C and D using a voltmeter as shown below. The voltmeter should display 5 volts when the brake pedal is activated.

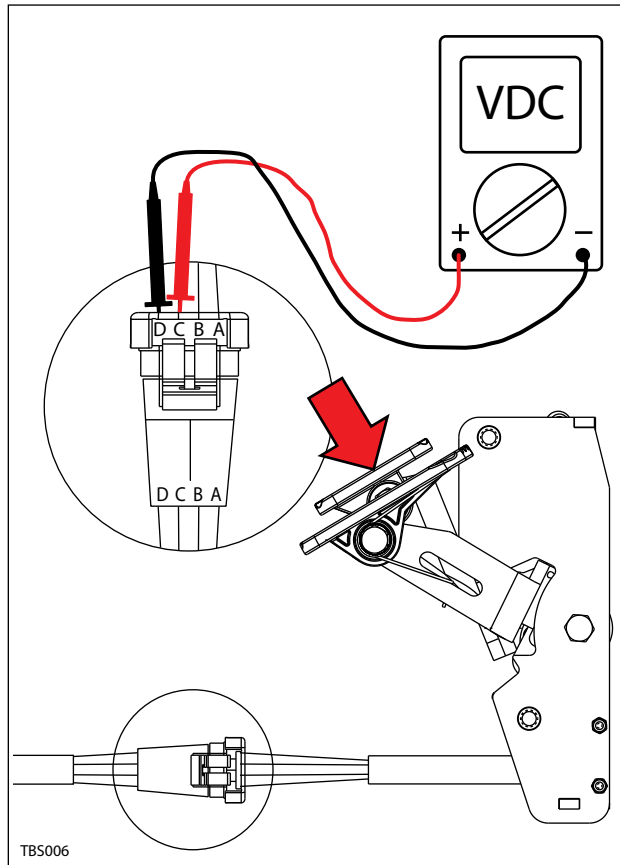

5. See "Propel Diagnostic Mode" in the TROUBLE SHOOTING section. The voltage in step 3 should match the LCD displayed voltage in Propel Diagnostic Mode.

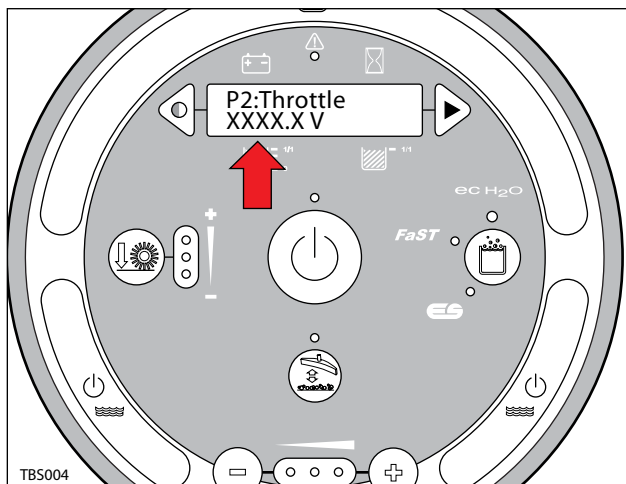

7. See "Propel Diagnostic Mode" in the TROUBLE SHOOTING section. The change in voltage in step 5 should correspond to a brake pedal "On" or "Off" LCD message.

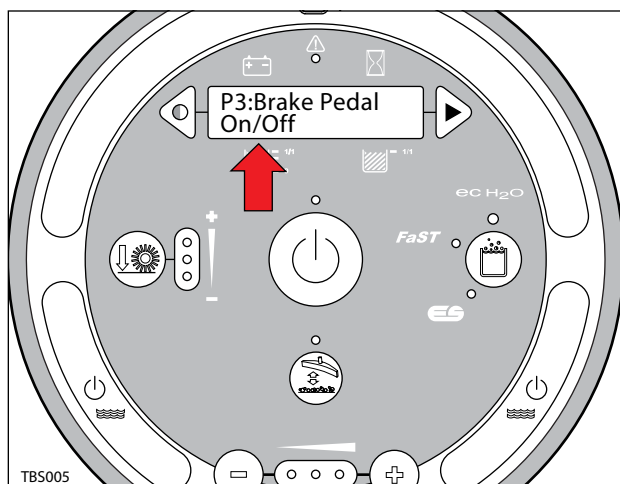

TESTING SIDE BRUSH LIFT ACTUATOR

FOR SAFETY: Before leaving or servicing machine, stop on level surface, turn off machine and remove key.

FOR SAFETY: When servicing machine, disconnect battery connection before working on machine.

FOR SAFETY: When servicing machine, avoid moving parts. Do not wear loose jackets, shirts, or sleeves when working on machine .

1. Key Off. Disconnect the side brush lift actuator from the wire harness.

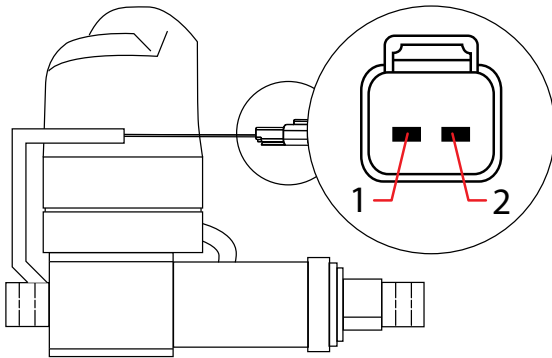

RSLA001

PIN ASSIGNMENT	
2	BLACK
1	BLACK

2. Apply battery voltage to the lift actuator using fuse-protected jumper leads as shown below. Be sure to connect battery + to terminal 1 and battery - to terminal 2. The actuator should retract completely. Replace the actuator if it fails to retract.

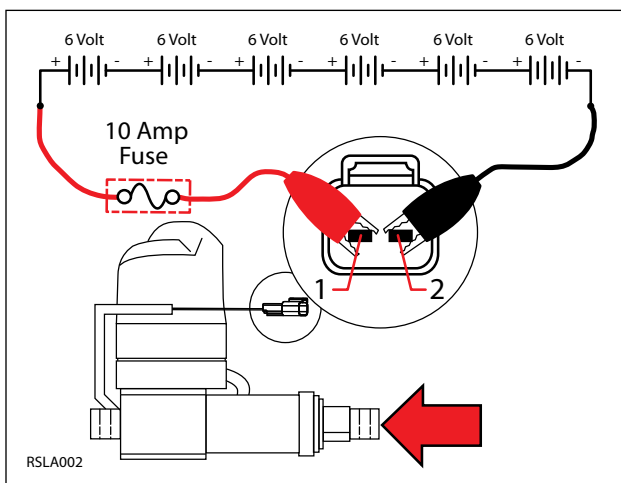

RSLA002

3. Reverse polarity and apply battery voltage to the lift actuator using fuse-protected jumper leads as shown below. Connect battery - to terminal 1 and battery + to terminal 2. The actuator should extend completely. Replace the actuator if it fails to extend.

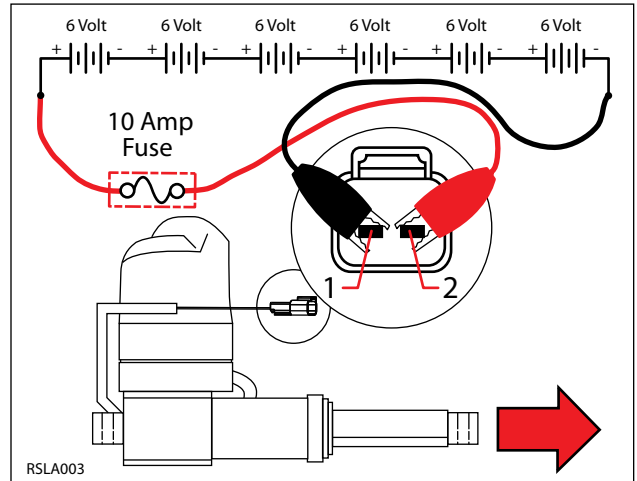

RSLA003

SERVICE

TESTING MAIN BRUSH LIFT ACTUATOR

FOR SAFETY: Before leaving or servicing machine, stop on level surface, turn off machine and remove key.

FOR SAFETY: When servicing machine, disconnect battery connection before working on machine.

FOR SAFETY: When servicing machine, avoid moving parts. Do not wear loose jackets, shirts, or sleeves when working on machine.

1. Key Off. Disconnect the main brush lift actuator from the wire harness.

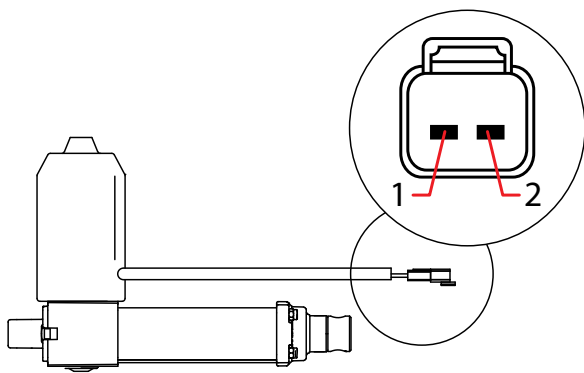

MAC1 A001

PIN ASSIGNMENT	
2	RED
1	BLACK

2. Apply battery voltage to the lift actuator using fuse-protected jumper leads as shown below. Be sure to connect battery + to terminal 1 and battery - to terminal 2. The actuator should retract completely. Replace the actuator if it fails to retract.

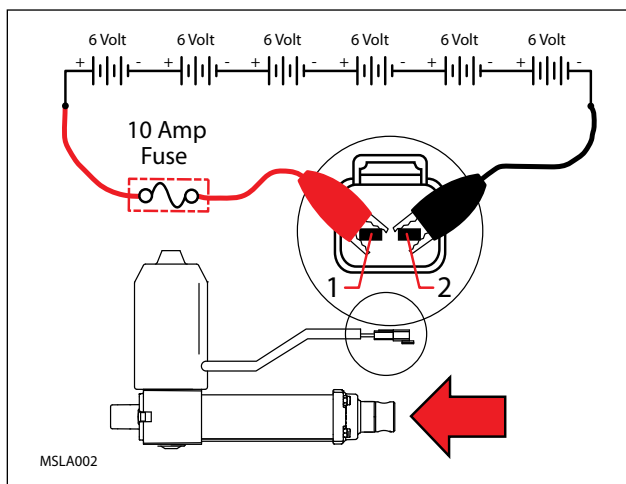

MSLA002

3. Reverse polarity and apply battery voltage to the lift actuator using fuse-protected jumper leads as shown below. Connect battery - to terminal 1 and battery + to terminal 2. The actuator should extend completely. Replace the actuator if it fails to extend.

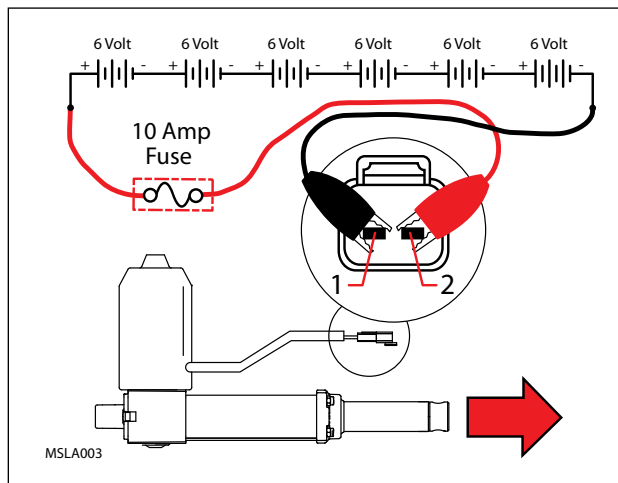

MSLA003

TESTING REAR SQUEEGEE LIFT ACTUATOR

FOR SAFETY: Before leaving or servicing machine, stop on level surface, turn off machine and remove key.

FOR SAFETY: When servicing machine, disconnect battery connection before working on machine.

FOR SAFETY: When servicing machine, avoid moving parts. Do not wear loose jackets, shirts, or sleeves when working on machine.

1. Key Off. Disconnect the rear squeegee lift actuator from the wire harness.

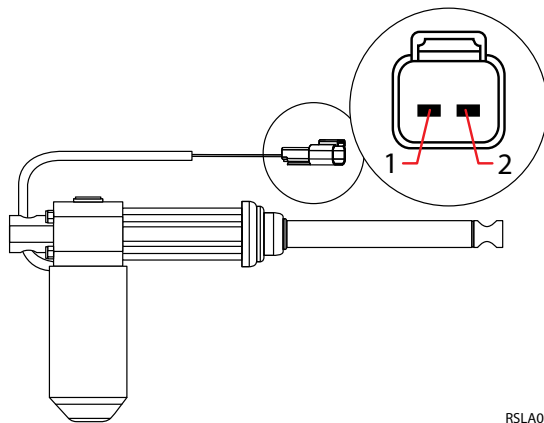

RSLA005

PIN ASSIGNMENT	
2	BLUE
1	BROWN

2. Apply battery voltage to the lift actuator using fuse-protected jumper leads as shown below. Be sure to connect battery + to terminal 1 and battery - to terminal 2. The actuator should retract completely. Replace the actuator if it fails to retract.

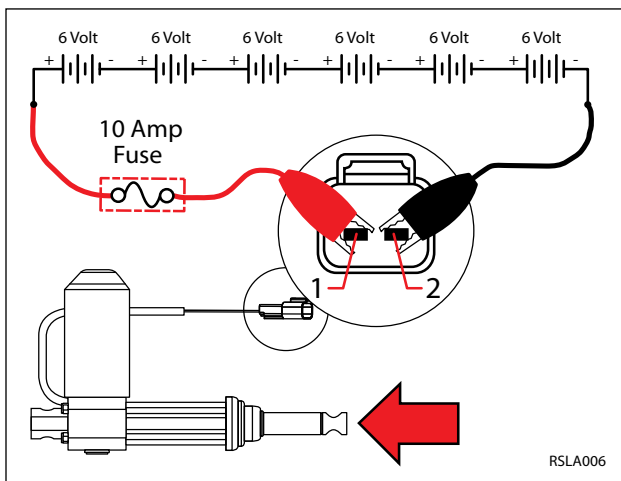

RSLA006

3. Reverse polarity and apply battery voltage to the lift actuator using fuse-protected jumper leads as shown below. Connect battery - to terminal 1 and battery + to terminal 2. The actuator should extend completely. Replace the actuator if it fails to extend.

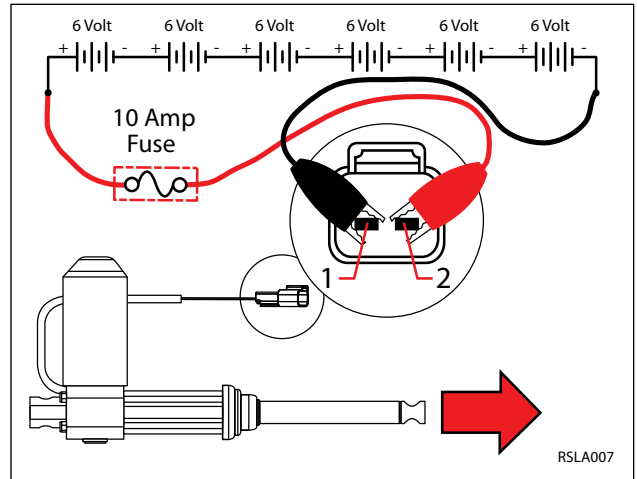

RSLA007

SERVICE

TESTING VACUUM FAN

FOR SAFETY: Before leaving or servicing machine, stop on level surface, turn off machine and remove key.

FOR SAFETY: When servicing machine, disconnect battery connection before working on machine.

1. Key Off. Disconnect vacuum fan from wire harness.

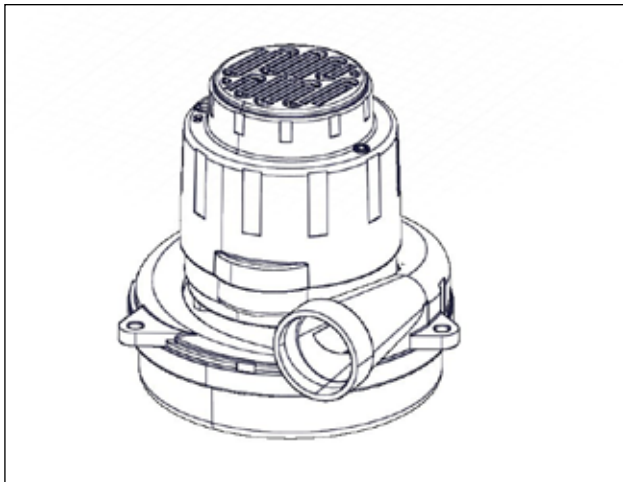

2. Key Off. Inspect carbon brushes. Replace carbon brushes if they are shorter than 10mm (0.375 in).



3. Apply battery voltage to the vacuum fan(s) using fuse-protected jumper leads as shown below. The fan should turn On. Replace the vacuum fan if it fails to turn On.

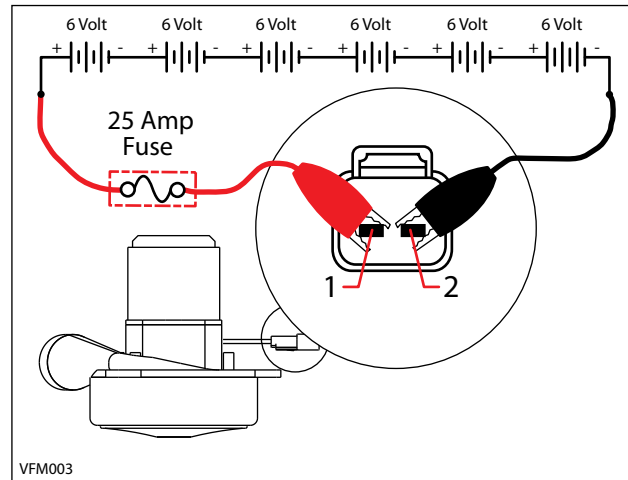

4. Reconnect vacuum fan(s) to wire harness. See "Manual Mode" in the TROUBLESHOOTING section. Activate the vacuum fan in Manual Mode. The amperage displayed should be approximately 14-20 Amps (avg. 16 Amps)

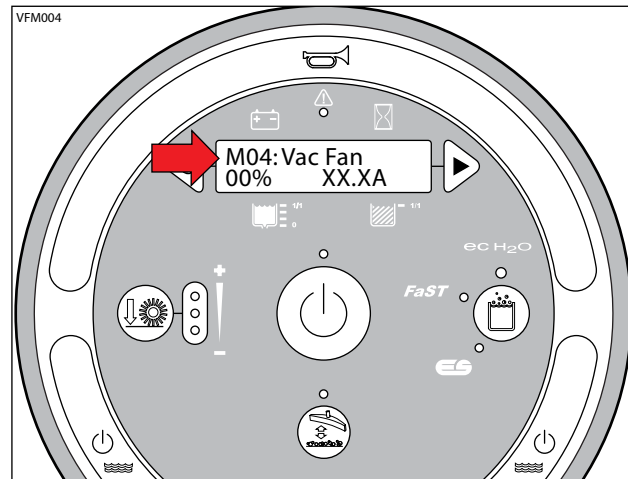

TESTING MAIN SCRUB BRUSH MOTOR(S)

FOR SAFETY: Before leaving or servicing machine, stop on level surface, turn off machine and remove key.

FOR SAFETY: When servicing machine, disconnect battery connection before working on machine.

1. Key Off. Disconnect the main brush motor from the wire harness.

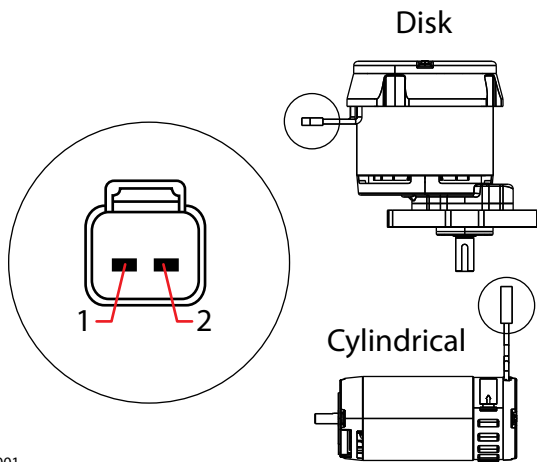

MBM001

PIN ASSIGNMENT	
2	BLACK
1	RED

2. Inspect carbon brushes. Replace carbon brushes if they are shorter than; Disk = 11mm (0.43 in), Cylindrical = 10mm (0.39 in).

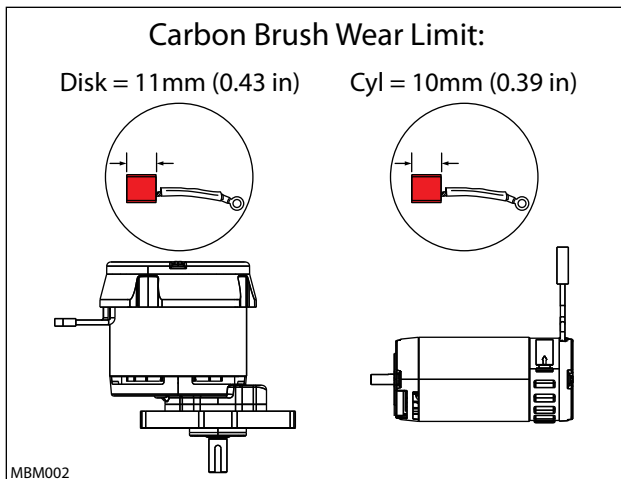

MBM002

3. Apply battery voltage to the main brush motor(s) using fuse-protected jumper leads as shown below. The brush motor should turn On. Replace the brush motor if it fails to turn On.

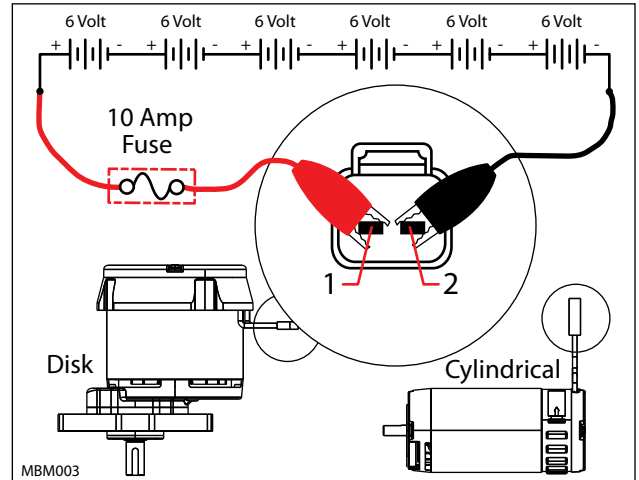

MBM003

SERVICE

TESTING SIDE BRUSH MOTOR

FOR SAFETY: Before leaving or servicing machine, stop on level surface, turn off machine and remove key.

FOR SAFETY: When servicing machine, disconnect battery connection before working on machine.

1. Key Off. Disconnect the side brush motor from the wire harness.

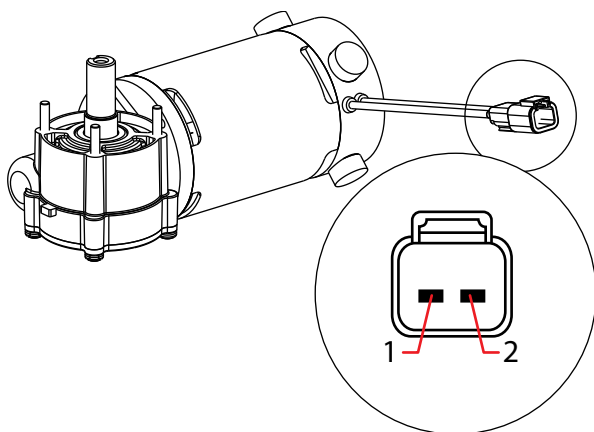

SBM001

PIN ASSIGNMENT	
2	BLACK
1	RED

2. Key Off. Inspect carbon brushes. Replace carbon brushes if they are shorter than 10mm (0.375 in).

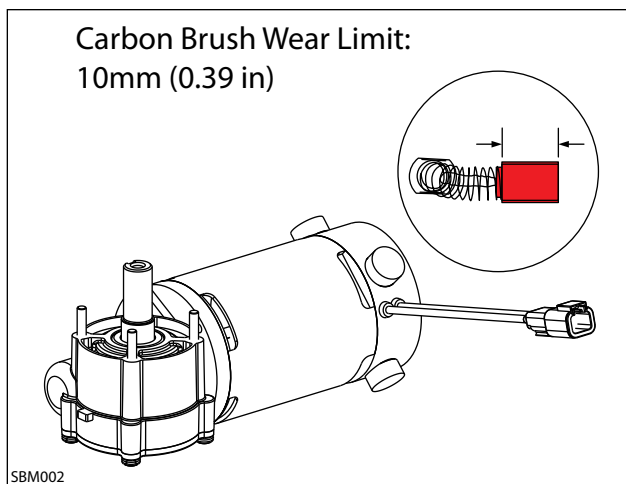

SBM002

3. Apply battery voltage to the side brush motor using fuse-protected jumper leads as shown below. The side brush motor should turn On. Replace the side brush motor if it fails to turn On.

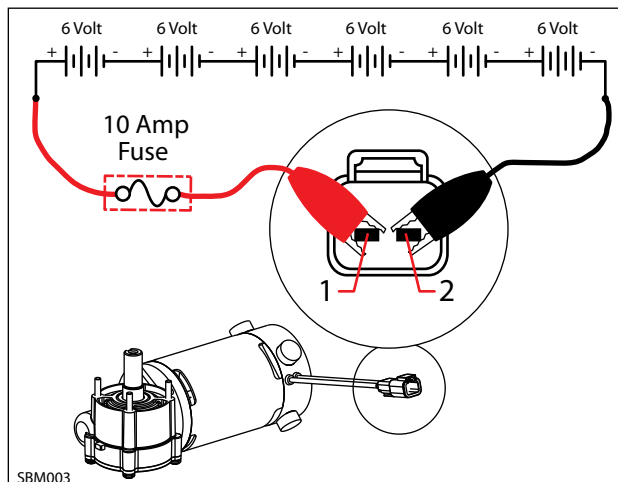

SBM003

TESTING ec-H2O PUMP

FOR SAFETY: Before leaving or servicing machine, stop on level surface.

1. Key Off. Disconnect ec-H2O pump outlet hose.

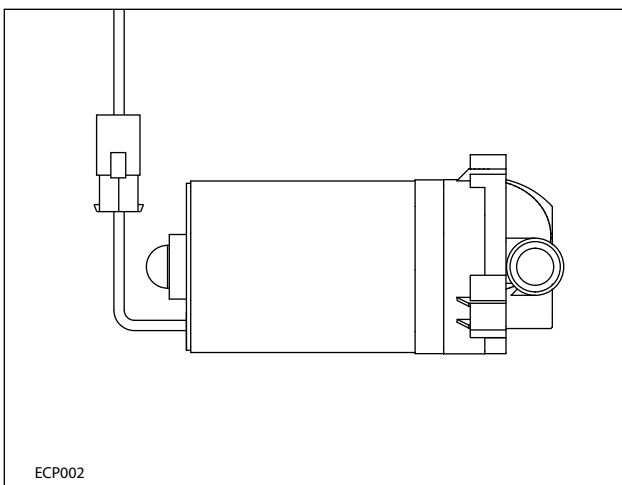

2. Fill the solution tank.
3. Connect a temporary outlet hose to the pump. The hose must be long enough to reach a 5 gallon bucket.

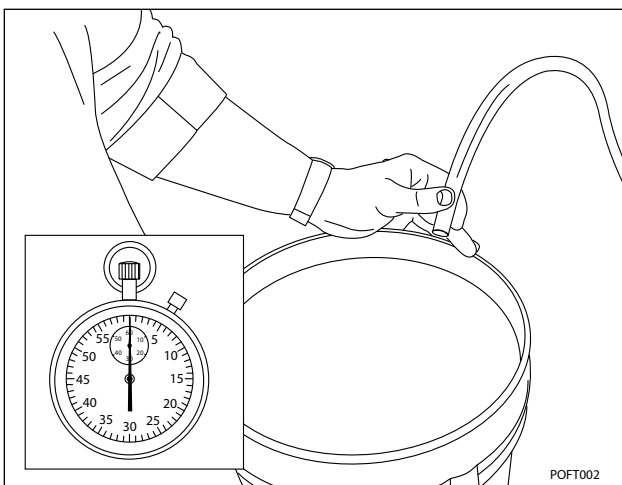

4. Enter Manual Mode and enable the ec-H2O system. See Manual Mode in the Troubleshooting section of this manual.

5. Use a stop watch to time how long it takes to fill a 5 gallon bucket. The open flow specification for the ec-H2O pump is 1.35 GPM. The pump should fill the 5 gallon bucket in approximately 3.5 - 4.0 minutes. Replace the pump if it takes longer than 4 minutes to fill and the pump has an adequate water supply.

NOTE: Open flow is different than system flow and should not be used for scrubbing mode water consumption calculations.

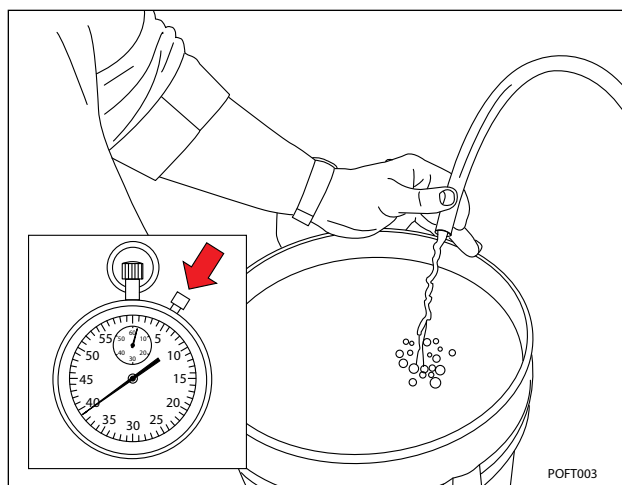

ADJUSTING ec-H2O FLOW RATE

See Configuration Mode in the Troubleshooting section of this manual.

SERVICE

TESTING ec-H2O PRESSURE SWITCH

FOR SAFETY: Before leaving or servicing machine, stop on level surface, turn off machine and remove key.

FOR SAFETY: When servicing machine, disconnect battery connection before working on machine.

1. Key Off. Disconnect the pressure switch from the wire harness and remove the switch from the machine.

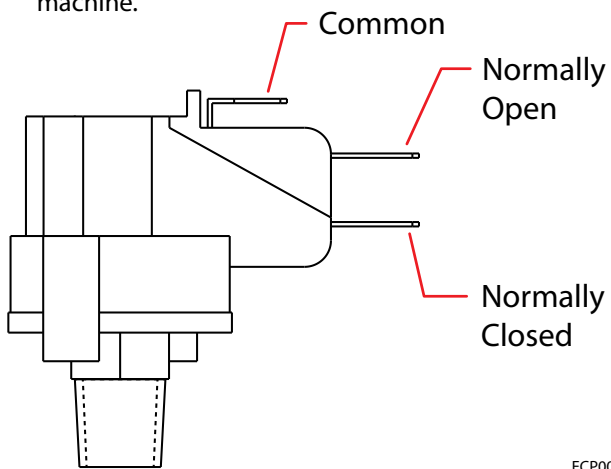

ECP001

2. Test the resistance of the switch using an ohmmeter between the common and normally closed terminals. There should be 0-1 ohms resistance. Replace the switch if the N.C. contacts are open.

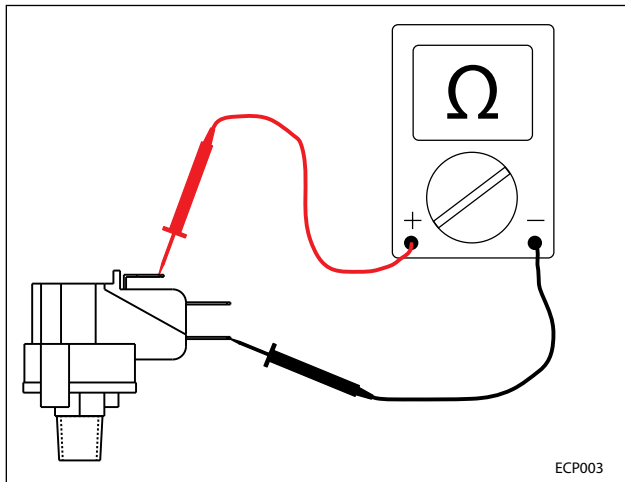

ECP003

3. Test the resistance of the switch using an ohmmeter between the common and normally open terminals. The switch should test as "O.L." or open. Replace the switch if the N.O. contacts are shorted.

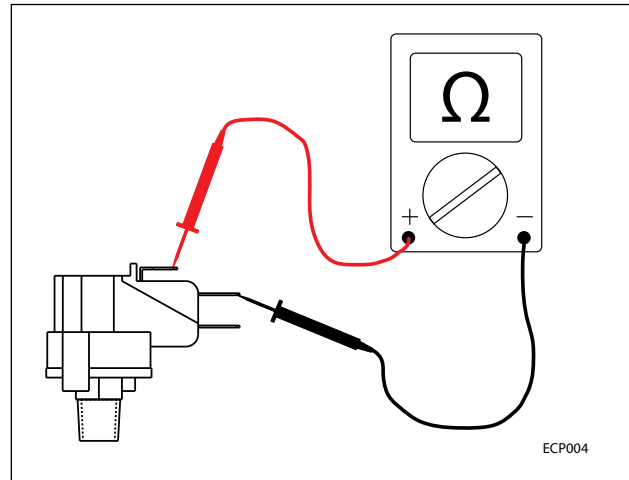

ECP004

4. Use a bicycle pump with pressure gauge to apply pressure to the switch as shown below. The normally open contacts should close at 25 +/- 2 psi (1.7 Bar), increasing pressure. Replace the switch if it does not open correctly.

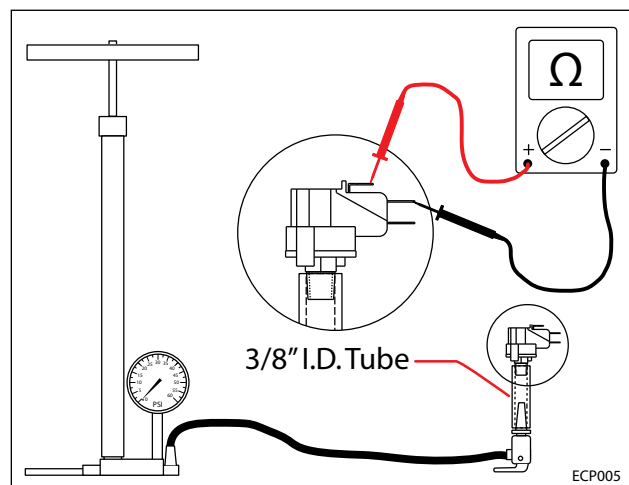

ECP005



TENNANT COMPANY
 Technical Publications #15
 701 North Liliac Drive
 P.O. Box 1452
 Minneapolis, MN 55440-9947

POSTAGE WILL BE PAID BY ADDRESSEE

BUSINESS REPLY MAIL
 FIRST CLASS MAIL PERMIT NO. 94 MINNEAPOLIS, MN

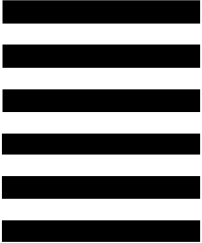

NO POSTAGE
 NECESSARY
 IF MAILED
 IN THE
 UNITED STATES

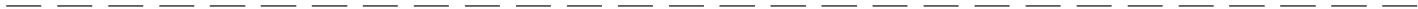

Fold along dotted lines
 Tape here



TENNANT COMPANY
 Technical Publications #15
 701 North Liliac Drive
 P.O. Box 1452
 Minneapolis, MN 55440-9947

POSTAGE WILL BE PAID BY ADDRESSEE

BUSINESS REPLY MAIL
 FIRST CLASS MAIL PERMIT NO. 94 MINNEAPOLIS, MN

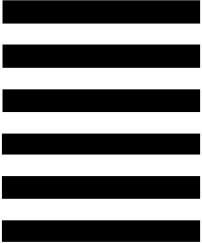

NO POSTAGE
 NECESSARY
 IF MAILED
 IN THE
 UNITED STATES

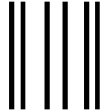

Fold along dotted lines
 Tape here

