

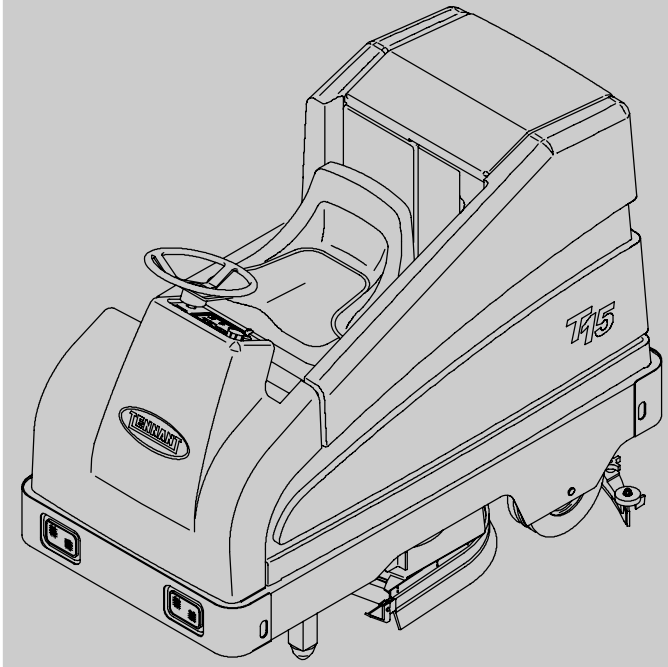

# T15



## Service Information Manual



***FaST***  
Foam Scrubbing Technology<sup>®</sup>  
The Safe Scrubbing Alternative<sup>®</sup>

**North America / International**

[www.tennantco.com](http://www.tennantco.com)

**331555**  
Rev. 00 (05-2007)



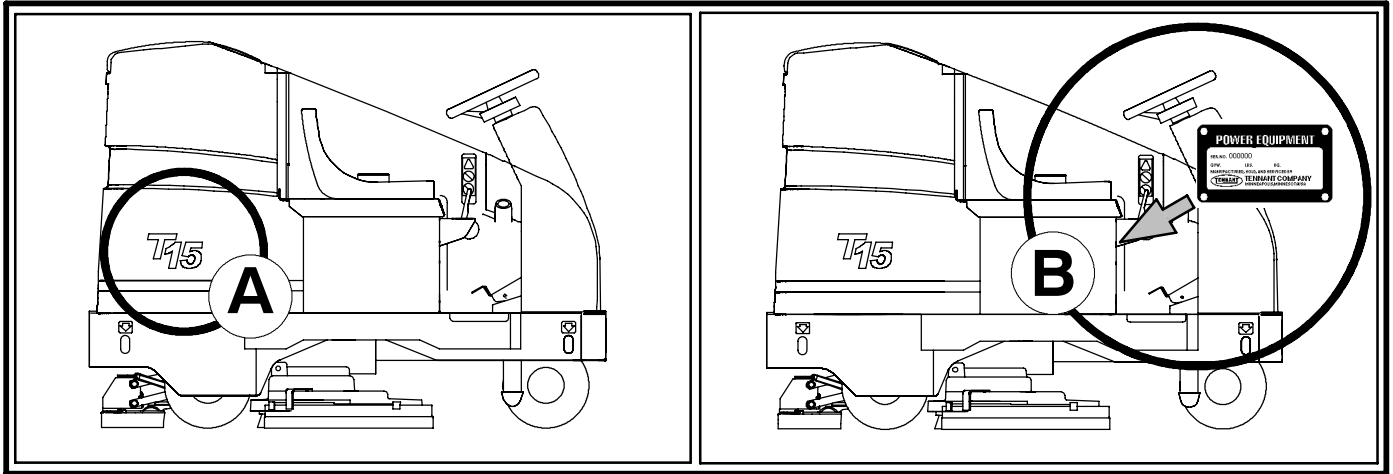

### FOR REPLACEMENT PARTS

Identify machine model and serial number.

1. **(A)** Identify the machine model.
2. **(B)** Identify the machine serial number from the data plate.

Refer to the TENNANT Parts Manual.

*NOTE: Only use TENNANT Company supplied or equivalent parts. Parts and supplies may be ordered online, by phone, by fax or by mail.*

### Tennant Company

PO Box 1452

Minneapolis, MN 55440

Phone: (800) 553-8033 or (763) 513-2850

[www.tennantco.com](http://www.tennantco.com)

Specifications and parts are subject to change without notice.

Copyright © 2007 TENNANT Company, Printed in U.S.A.

# T15 Service Information Manual

## Table of Contents

(Page 1 of 3)

	page
<b>SAFETY PRECAUTIONS</b> .....	vi
<b>GENERAL MACHINE INFORMATION</b>	
Component Locator.....	2 to 11
Touch Panel Detail.....	3
Switches & Circuit Breakers.....	4
Specifications.....	12 to 14
Dimensions & Capacities.....	12
Performance.....	12
Power Type.....	13
Tires.....	13
FaST System.....	13
Dimensional Drawings.....	14
Basic Troubleshooting.....	15 to 16
<b>MAINTENANCE &amp; REPAIR</b>	
Maintenance Checkpoints.....	18
Maintenance Chart.....	19
Lubrication.....	20
Steering Caster Pivot Bearing.....	20
Rear Squeegee Casters.....	20
Steering Gear Chain.....	20
Batteries.....	21 to 26
Charging Batteries.....	22
To Replace Batteries.....	25
Control Panel.....	27 to 28
To Access Control Panel.....	27
Instrument Panel.....	29 to 36
To Replace Touch Panel.....	29
To Replace Circuit Board.....	34
Circuit Breakers.....	37 to 42
Resettable Circuit Breakers.....	37
To Replace Circuit Breaker.....	38
Fuses.....	41
To Replace Fuse.....	41
Directional Control Pedal.....	43 to 46
To Replace Propel Motor Controller.....	44
To Replace Taillight Bulb.....	46
Scrub Head.....	47 to 65
Scrub Head Links.....	47
To Replace Scrub Head Links.....	48
To Remove Disc Scrub Head.....	49
To Install Disc Scrub Head.....	51
To Replace Disc Scrub Head Brush Motor.....	53
To Remove Cylindrical Scrub Head.....	57
To Install Cylindrical Scrub Head.....	59
To Replace Cylindrical Scrub Head Brush Motor.....	61
Cylindrical Brush Drive Belt.....	66 to 69
To Replace Brush Drive Belt.....	66
Disc Scrub Head Skirts.....	70 to 71
Scrub Head Floor Skirts.....	70
To Adjust Disc Scrub Head Skirts.....	70
To Replace Disc Scrub Head Skirts.....	71
Cylindrical Brush Head Debris Tray.....	72 to 75
To Remove Debris Tray.....	72
To Install Debris Tray.....	74
To Replace Debris Tray Skirt.....	75
Scrub Brushes.....	76 to 82
Disc Scrub Brushes.....	76
To Replace Disc Scrub Brushes.....	76
Cylindrical Scrub Brushes.....	78
To Replace Cylindrical Scrub Brushes.....	78
To Check and Adjust Cylindrical Brush Pattern.....	80
Scrub Head Lift Actuator.....	83 to 87
To Replace Scrub Head Lift Actuator.....	84

# T15 Service Information Manual

## Table of Contents

(Page 2 of 3)

MAINTENANCE & REPAIR (continued)	page
Solution System.....	88 to 104
Recovery Tank.....	88
To Remove Recovery Tank.....	89
To Install Recovery Tank.....	93
Solution Tank.....	96
To Remove Solution Tank.....	97
To Install Solution Tank.....	101
Manual Solution Valve.....	105 to 107
To Replace Solution Valve.....	105
Solution Solenoid Valve.....	108 to 110
To Replace Solution Solenoid Valve.....	108
FaST System.....	111
FaST Supply Hose Connector.....	111
FaST Solution Filter Screen.....	111
ES Pump.....	112 to 114
To Replace ES Pump.....	112
Squeegees.....	115 to 122
To Remove Rear Squeegee Assembly.....	115
To Install Rear Squeegee Assembly.....	117
To Level Rear Squeegee.....	118
To Adjust Rear Squeegee Blade Deflection.....	120
Rear Squeegee Casters.....	122
To Adjust Rear Squeegee Guide Roller.....	122
Rear Squeegee Blades.....	123 to 133
To Replace or Rotate Rear Squeegee (Rear) Blade.....	123
To Replace or Rotate Rear Squeegee (Front) Blade.....	125
Rear Squeegee Wheel Cams.....	128
Rear Squeegee Leveling Knob.....	128
To Replace Rear Squeegee Lift Cable.....	129
Side Squeegee Blades.....	132
To Replace Side Squeegee Blades.....	133
Squeegee Lift Actuator.....	134 to 137
To Replace Rear Squeegee Lift Actuator.....	135
Vacuum Fan.....	138 to 143
To Remove Vacuum Fan Assembly.....	138
To Install Vacuum Fan Assembly.....	140
To Replace Vacuum Fan.....	142
Pre-Sweep Brushes.....	144 to 149
Pre-Sweep Disk Brushes.....	144
Replacing the Disk Brushes.....	144
Pre-Sweep Cylindrical Brush.....	146
Checking and Adjusting Cylindrical Brush Pattern.....	146
Replacing the Pre-Sweep Cylindrical Brush.....	148
Pre-Sweep Skirts and Seals.....	150
Pre-Sweep Side Skirts.....	150
Pre-Sweep Recirculation Skirt.....	150
Pre-Sweep Rear Skirt.....	150
Pre-Sweep Brush Drive Belt.....	151
Static Drag Strap.....	152
Tires.....	152 to 178
Rear Tires and Wheels.....	153
To Remove Rear Tire.....	153
To Install Rear Tire.....	154
To Replace Rear Wheel Bearings.....	155
Front Tire and Wheel.....	157
Front Wheel Support Caster Bearing Assembly.....	157
To Remove Front Drive Assembly.....	157
To Install Front Drive Assembly.....	159
Propel Motor Service.....	160
General information.....	160
Terminal Connections.....	161
Electric Brake Disassembly.....	162
Brake Disk Replacement.....	166
Tire Replacement.....	167
Commutator Brush Replacement.....	171
To Replace Drive Assembly Caster Bearing and Thrust Washers.....	174
To Replace Drive Assembly Pivot Cone Bearing.....	177

# T15 Service Information Manual

## Table of Contents

(Page 3 of 3)

<b>MAINTENANCE &amp; REPAIR</b> (continued)	page
Steering.....	179 to 189
To Adjust Steering Chain.....	179
To Replace Steering Chain.....	180
To Replace Large Steering Sprocket.....	181
To Replace Small Steering Sprocket.....	182
To Replace Steering Housing Bearings.....	184
To Replace Steering U-joint.....	188
Seat.....	190 to 193
Operator Seat.....	190
To Remove Seat Assembly.....	190
To Install Seat Assembly.....	192
To Adjust Seat Position.....	193
Pushing, Towing, and Transporting the Machine.....	194 to 196
Pushing or Towing the Machine.....	194
Transporting the Machine.....	194
Machine Jacking.....	196
Storage Information.....	197
Freeze Protection.....	197
<b>ELECTRICAL</b>	
Electrical Schematics.....	200 to 202
Harness Drawings.....	203 to 210
Electrical Symbols & Terms.....	211
Key Switch.....	212
Key OFF Power Distribution.....	213
Key START Power Distribution.....	214
Key ON Power Distribution.....	215
Power Up Troubleshooting.....	216
Touch Panel Wiring.....	217
Touch Panel Troubleshooting.....	218
Scrub Brushes ON.....	219
Vacuum Fan(s) ON & Squeegee DOWN.....	220
Vacuum Fan(s) OFF & Squeegee UP.....	221
Vacuum Fan Troubleshooting.....	222
Squeegee Troubleshooting.....	224
Scrub Head DOWN & Conventional Solution Valve ON.....	226
Scrub Head UP.....	227
Forward Propel.....	228
Reverse Propel.....	229
Neutral (No Propel) with Brake Pedal Depressed.....	230
Propel Controller.....	231 to 233
Diagnostics and Troubleshooting.....	231
Operating Lights.....	234
Horn ON.....	234
Extended Scrub (ES) System ON.....	235
Power Wand ON.....	235
ES System Troubleshooting.....	236 to 237
ES Filter Flush Troubleshooting.....	238
Pre-Sweep System ON.....	239
Pre-Sweep Dust Control ON.....	240
FaST System ON.....	241
Battery Charger Troubleshooting.....	242 to 246
Machine Control Board Connectors.....	247
Propel Controller Connectors.....	248
Operating & Configuration Modes.....	249 to 260
Normal Mode.....	250
Self-Test Mode.....	252
Error Codes.....	253
Troubleshooting.....	254
Manual Mode.....	256
Enable/Disable Chart.....	257
Input Display Mode.....	258
Restricted Down Pressure Mode.....	259
Software Revision Date Display Mode.....	260

# T15 Safety Precautions

## SAFETY PRECAUTIONS

The following symbols are used throughout this manual as indicated in their description:



**WARNING:** To warn of hazards or unsafe practices that could result in severe personal injury or death.

**FOR SAFETY:** To identify actions that must be followed for safe operation of equipment.

This machine is designed solely for scrubbing dirt and dust in an indoor environment. Tennant does not recommend using this machine in any other environment.

The following information signals potentially dangerous conditions to the operator or equipment. Read this manual carefully. Know when these conditions can exist. Locate all safety devices on the machine. Then, take necessary steps to train machine operating personnel. Report machine damage or faulty operation immediately. Do not use the machine if it is not in proper operating condition.



**WARNING:** Batteries emit hydrogen gas. Explosion or fire can result. Keep sparks and open flame away. Keep covers open when charging.



**WARNING:** Flammable materials can cause an explosion or fire. Do not use flammable materials in tank(s).



**WARNING:** Flammable materials or reactive metals can cause an explosion or fire. Do not pickup.

### FOR SAFETY:

- 1. Do not operate machine:**
  - Unless trained and authorized.
  - Unless operation manual is read and understood.
  - With brake disabled.
  - In flammable or explosive areas unless designed for use in those areas.
- 2. Before starting machine:**
  - Make sure all safety devices are in place and operate properly.
  - Check brakes and steering for proper operation (if so equipped).

- 3. When using machine:**
  - Go slow on inclines and slippery surfaces.
  - Use care when backing machine.
  - Follow mixing and handling instructions on chemical containers.
- 4. Before leaving or servicing machine:**
  - Stop on level surface.
  - Turn off machine and remove key.
- 5. When servicing machine:**
  - Avoid moving parts. Do not wear loose jackets, shirts, or sleeves when working on machine.
  - Block machine tires before jacking machine up.
  - Jack machine up at designated locations only. Block machine up with jack stands.
  - Use hoist or jack that will support the weight of the machine.
  - Wear eye and ear protection when using pressurized air or water.
  - Disconnect battery connections before working on machine.
  - Avoid contact with battery acid.
  - Use Tennant supplied or equivalent replacement parts.
- 6. When loading/unloading machine onto/off truck or trailer.**
  - Turn off machine.
  - Use truck or trailer that will support the weight of the machine.
  - Use winch. Do not push the machine onto/off the truck or trailer unless the load height is 380 mm (15 in) or less from the ground.
  - Block machine tires.
  - Tie machine down to truck or trailer.



**T15**



# **GENERAL MACHINE INFORMATION**

# T15 Component Locator

(page 1 of 10)

G

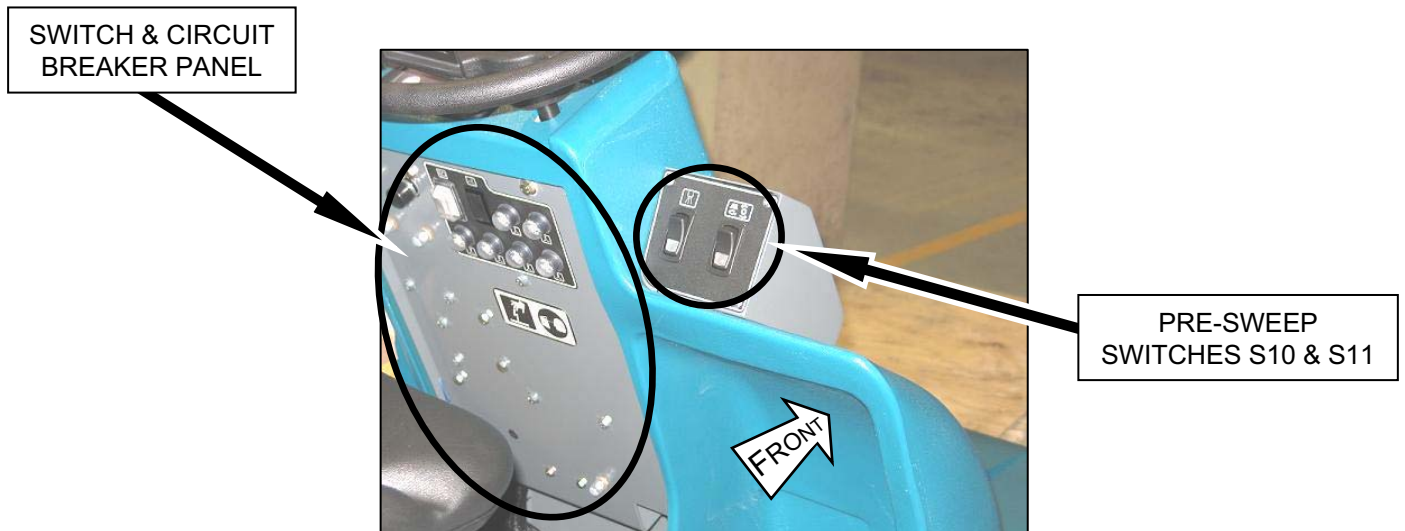
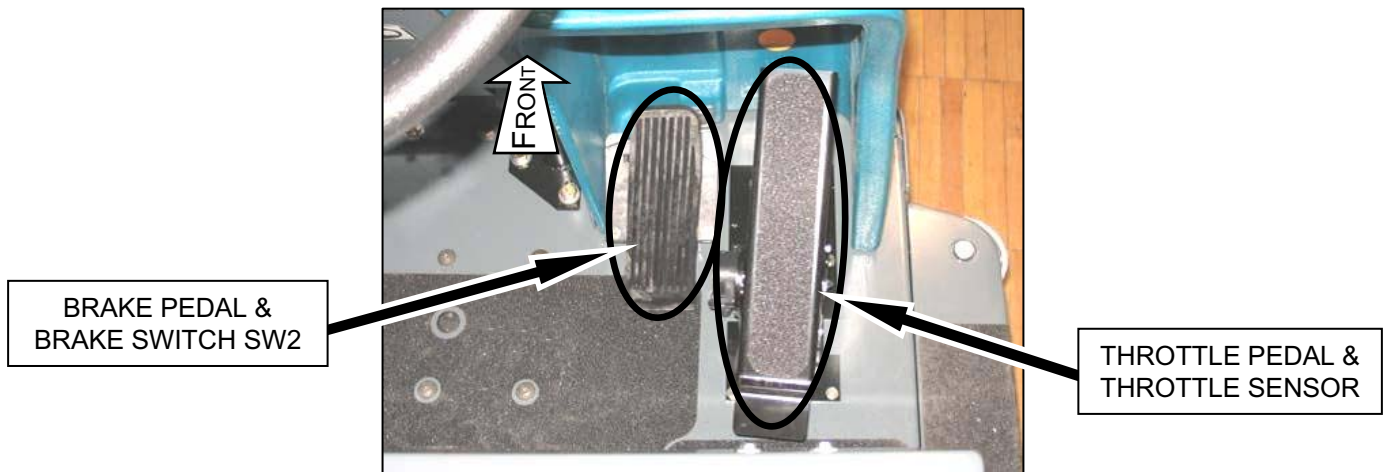



# T15 Component Locator

(page 2 of 10)

## Touch Panel Detail

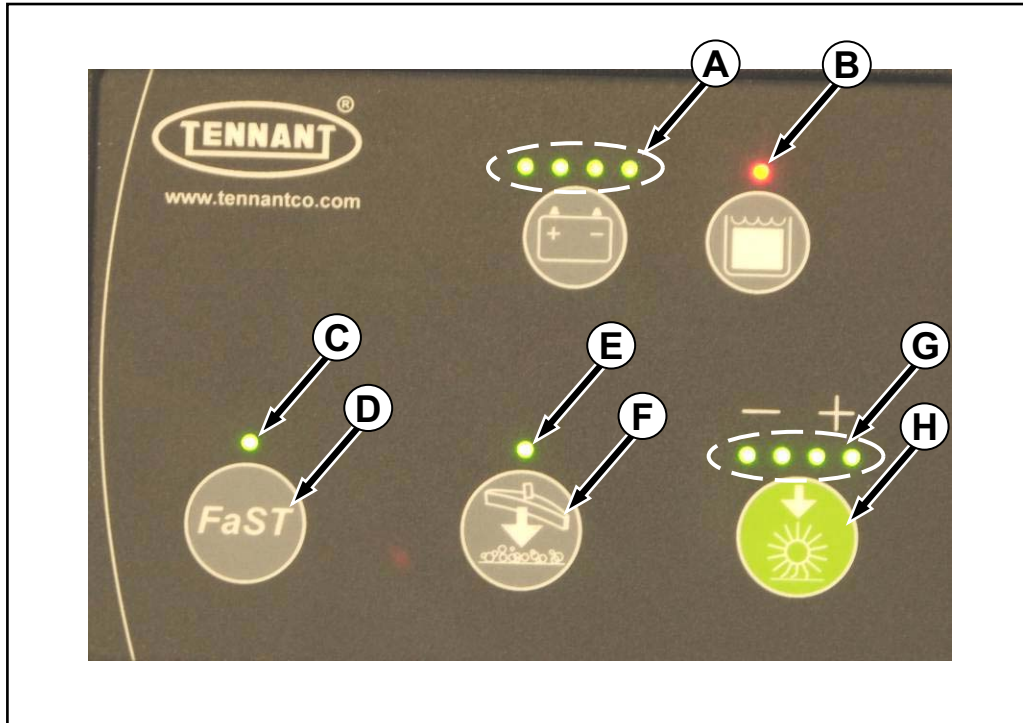

- A. Battery discharge indicator**
- B. Recovery tank full indicator**
- C. FaST/ES enabled indicator**
- D. FaST/ES ON/OFF button**
- E. Squeegee/Vacuum Fan indicator**
- F. Squeegee/Vacuum Fan ON/OFF button**
- G. Scrub Head Pressure indicator**
- H. Scrub System ON/OFF button**

# T15 Component Locator

(page 3 of 10)

## Switches & Circuit Breakers

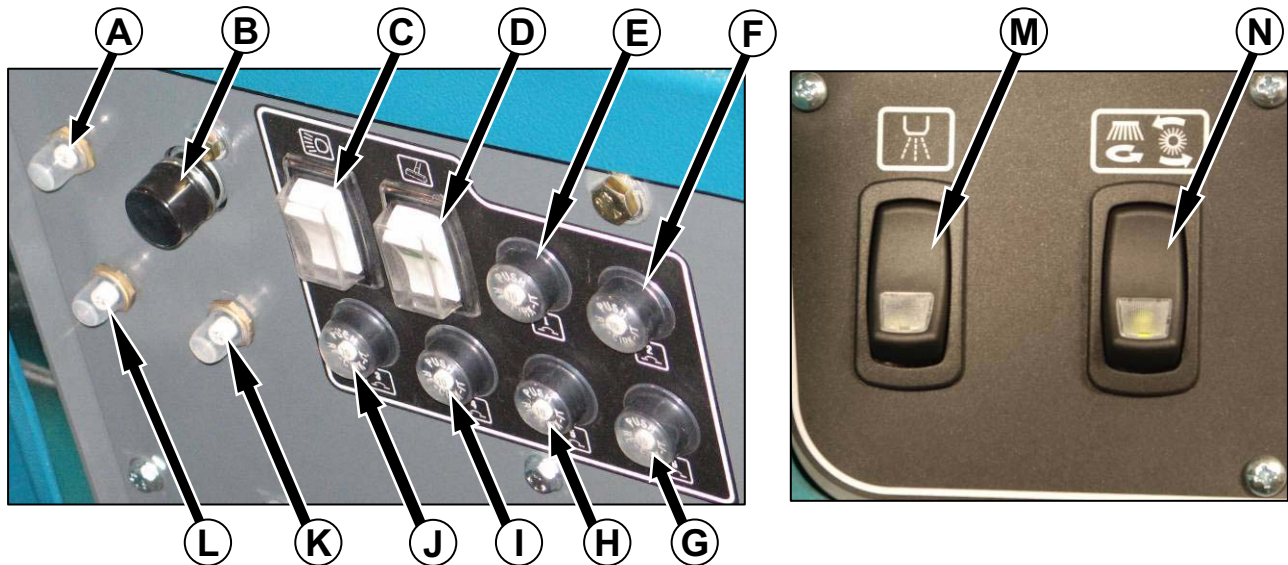

- A. **CB7 – 20 Amp Circuit Breaker – Single Vacuum Fan (or)  
40 Amp Circuit Breaker – Dual Vacuum Fans (option)**
- B. **S7 – Horn Button**
- C. **S8 – Operating Lights Switch**
- D. **S6 – Power Wand Switch (option)**
- E. **CB1 – 10 Amp Circuit Breaker – Machine Power**
- F. **CB2 – 10 Amp Circuit Breaker – Battery Discharge Indicator**
- G. **CB6 – 15 Amp Circuit Breaker – Machine Control Board & Touch Panel**
- H. **CB5 – 10 Amp Circuit Breaker – Horn**
- I. **CB4 – 10 Amp Circuit Breaker – Scrub Head Actuator, Back Up  
Alarm (option) and Power Wand (option)**
- J. **CB3 – 15 Amp Circuit Breaker – Operating Lights**
- K. **CB9 – 30 Amp Circuit Breaker – Left Disk Scrub Brush Motor (or)  
Rear Cylindrical Scrub Brush Motor**
- L. **CB8 – 30 Amp Circuit Breaker – Right Disk Scrub Brush Motor (or)  
Front Cylindrical Scrub Brush Motor**
- M. **S11 – Pre-Sweep Dust Control Switch (option)**
- N. **S10 – Pre-Sweep System ON/OFF Switch (option)**

# T15 Component Locator

(page 4 of 10)

## Switches & Circuit Breakers

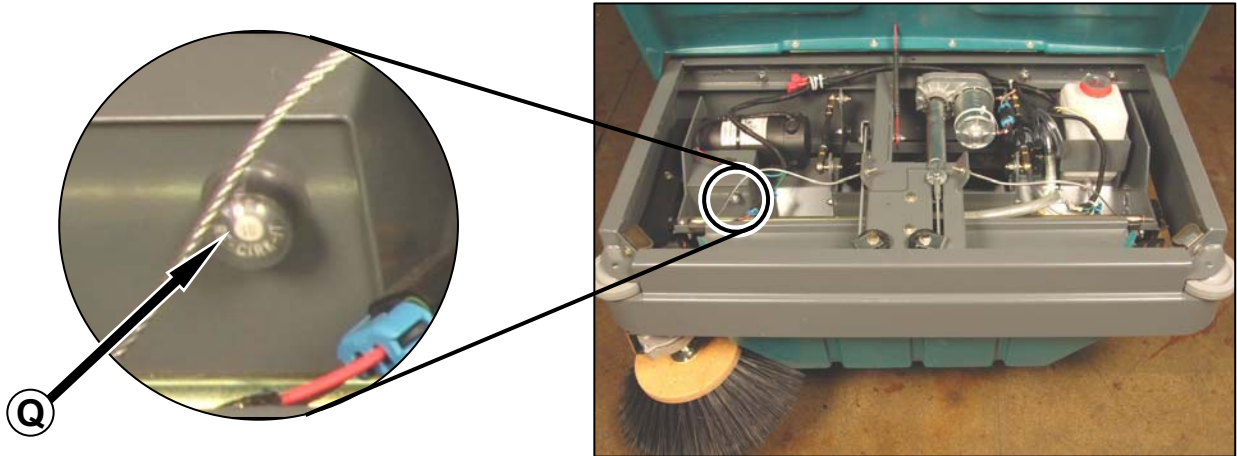
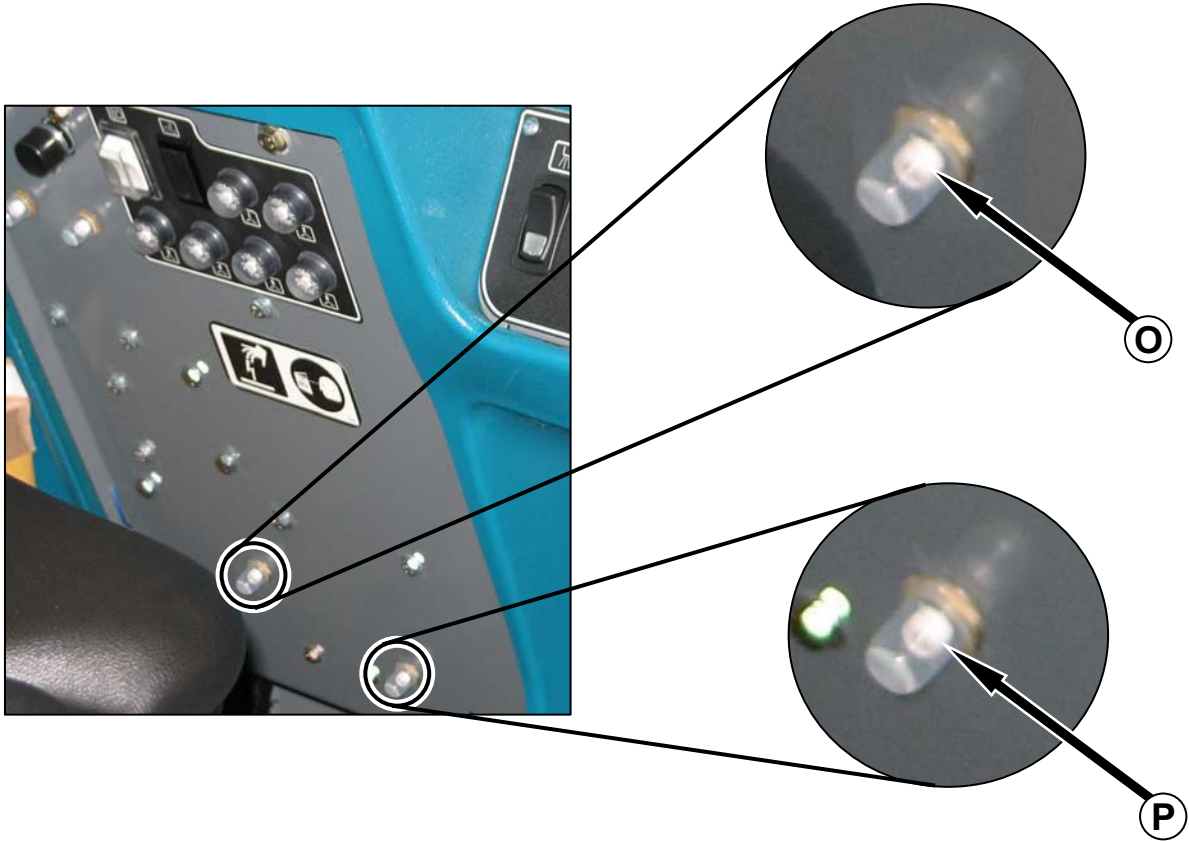

- O. CB11 – 10 Amp Circuit Breaker – FaST System**
- P. CB10 – 25 Amp Circuit Breaker – Pre-Sweep System (option)**
- Q. CB12 – 10 Amp Circuit Breaker – Pre-Sweep Side Brush(es) (option)**

# T15 Component Locator

(page 5 of 10)

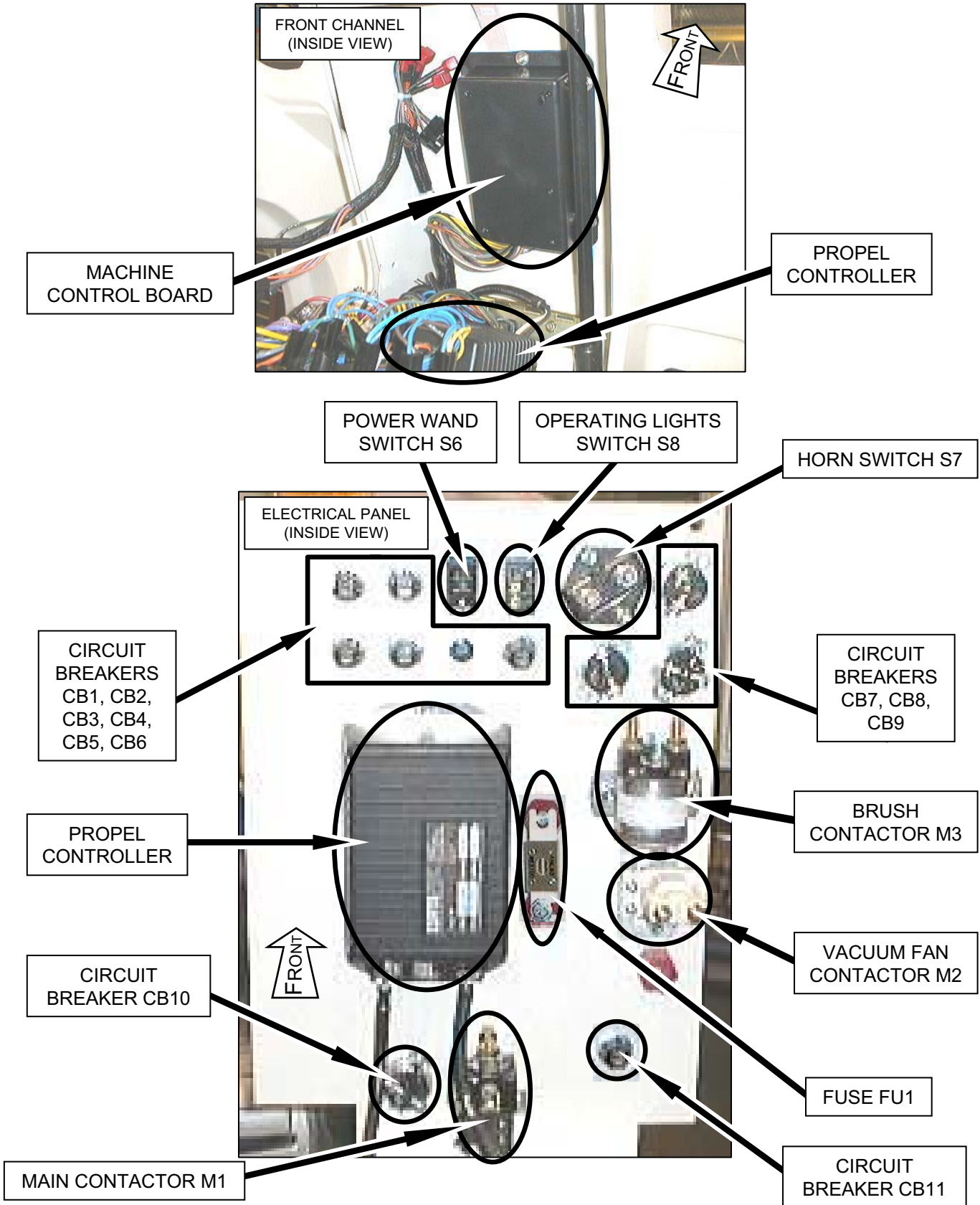

# T15 Component Locator

(page 6 of 10)

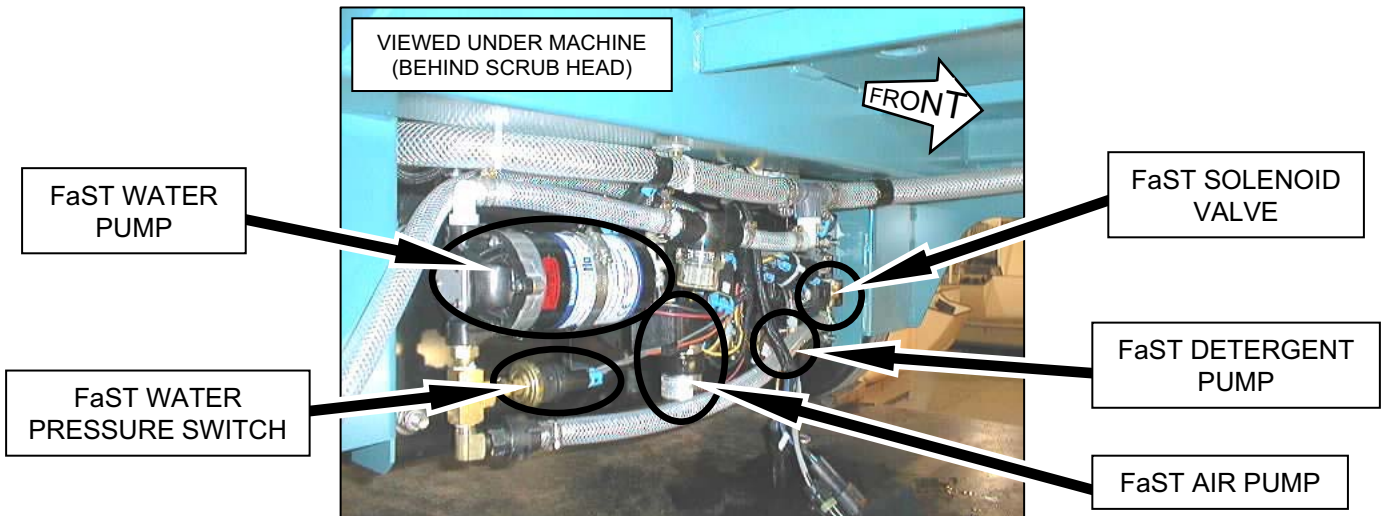
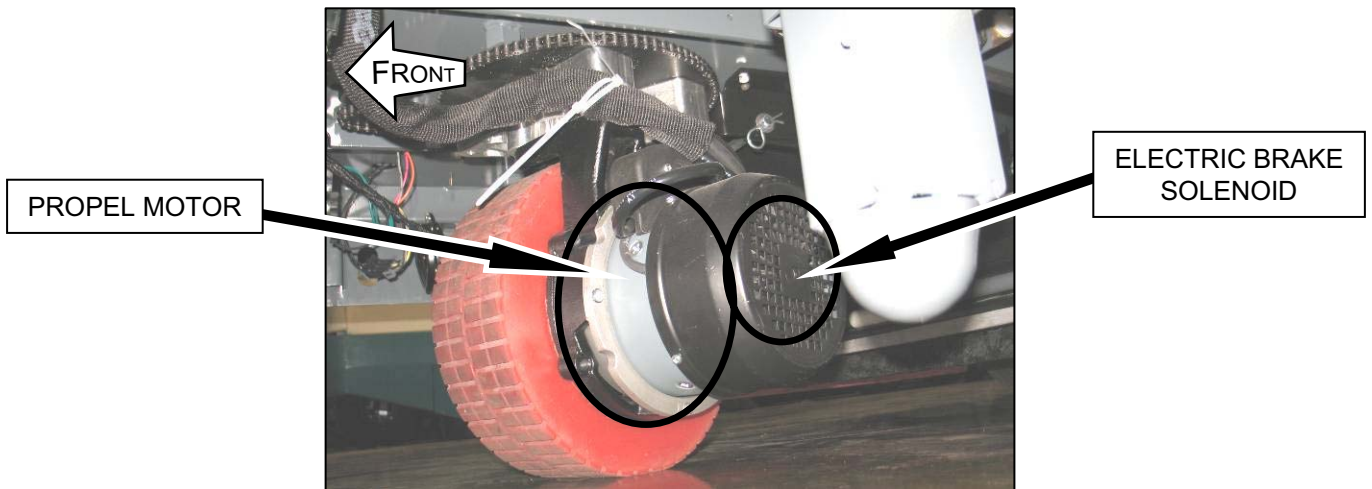
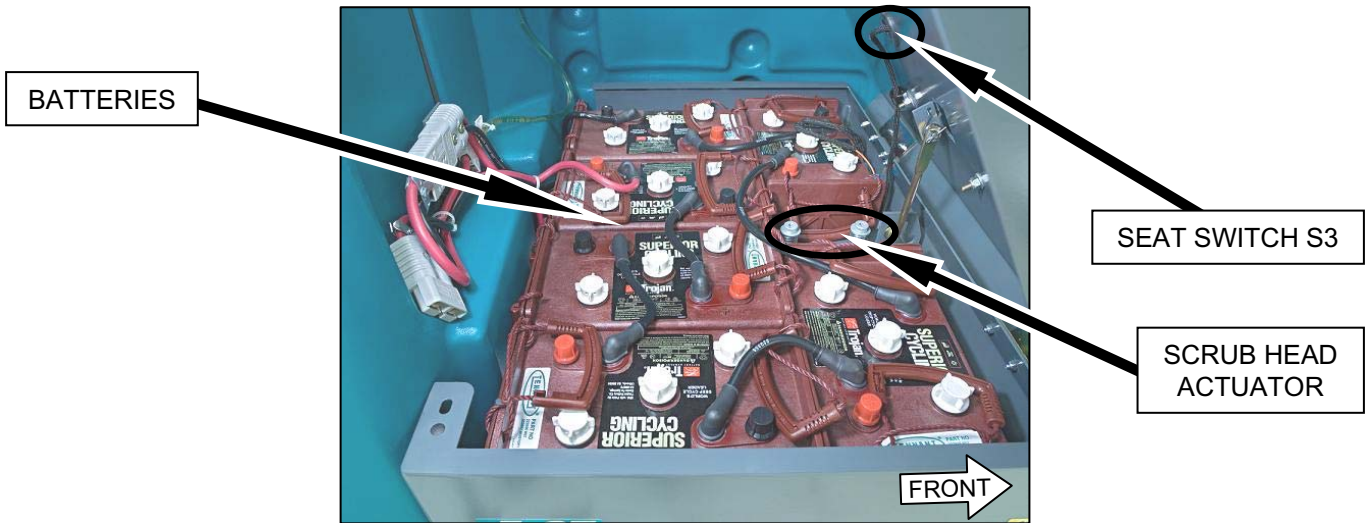

# T15 Component Locator

(page 7 of 10)

**G**

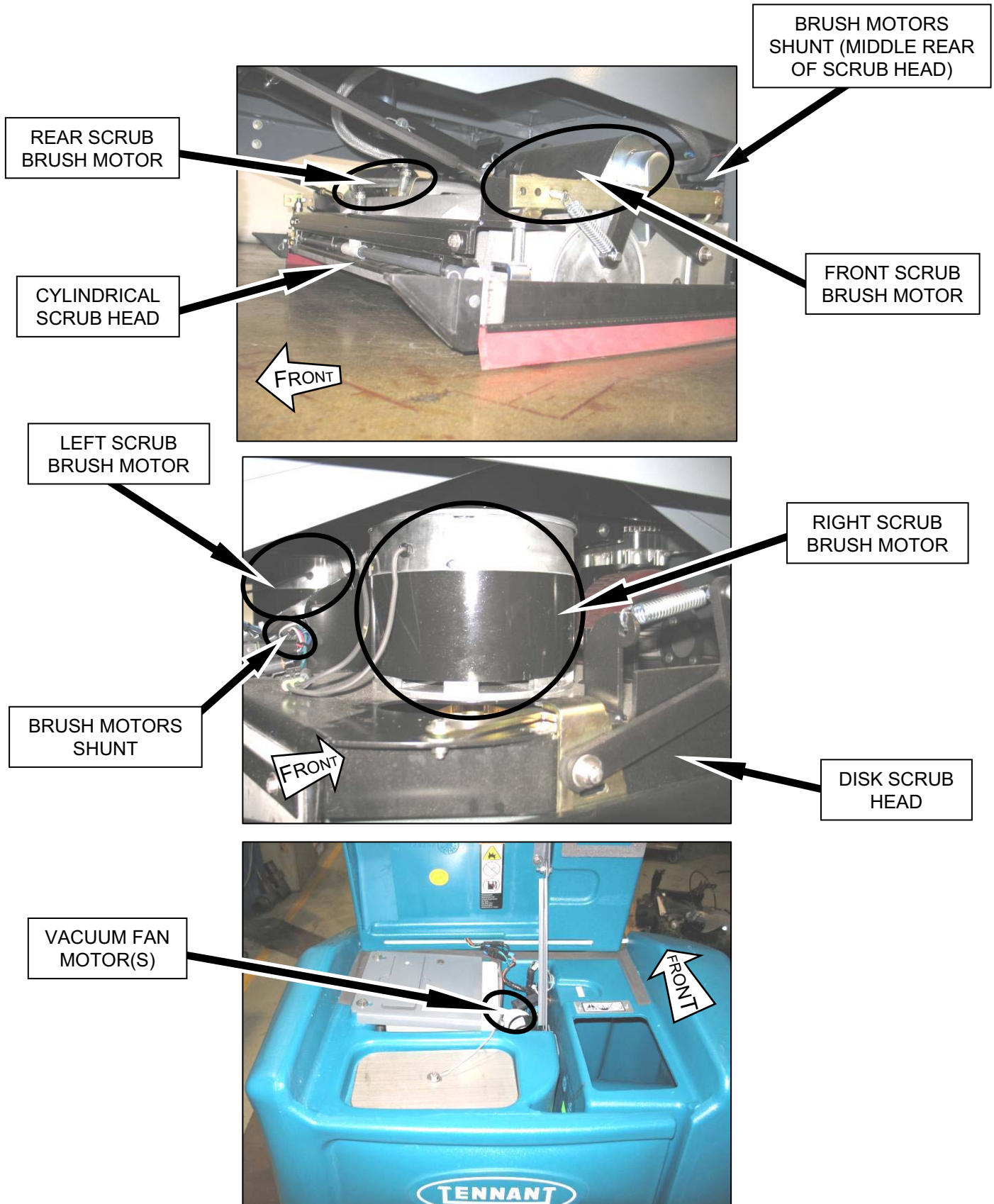

# T15 Component Locator

(page 8 of 10)



RECOVERY TANK FULL  
FLOAT SWITCH S4



SOLUTION TANK FULL  
FLOAT SWITCH S9

RECOVERY TANK HALF  
FULL FLOAT SWITCH S5

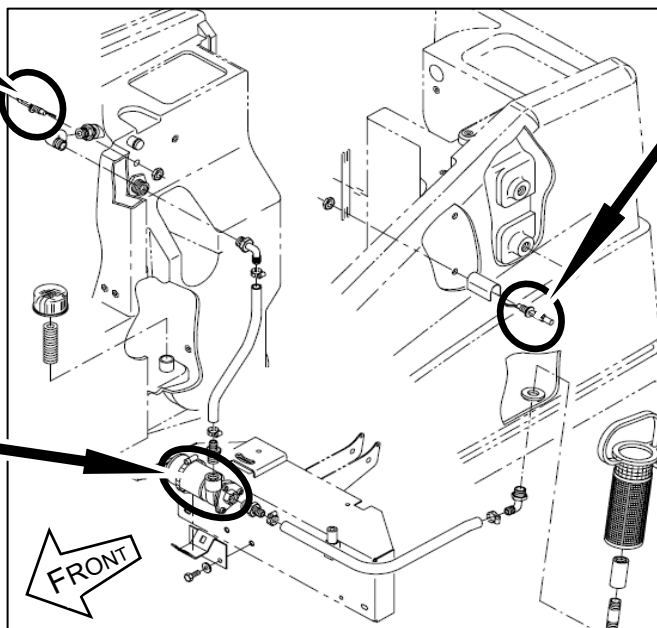

ES PUMP

# T15 Component Locator

(page 9 of 10)

G

CONVENTIONAL SOLUTION VALVE

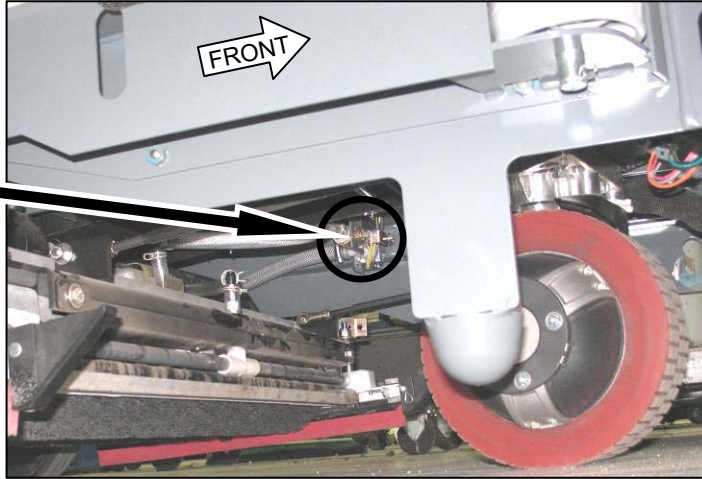

SQUEEGEE ACTUATOR

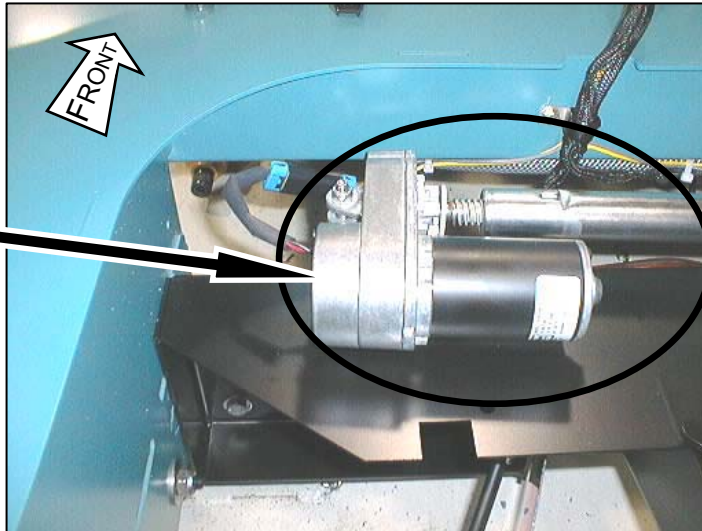

POWER WAND PUMP

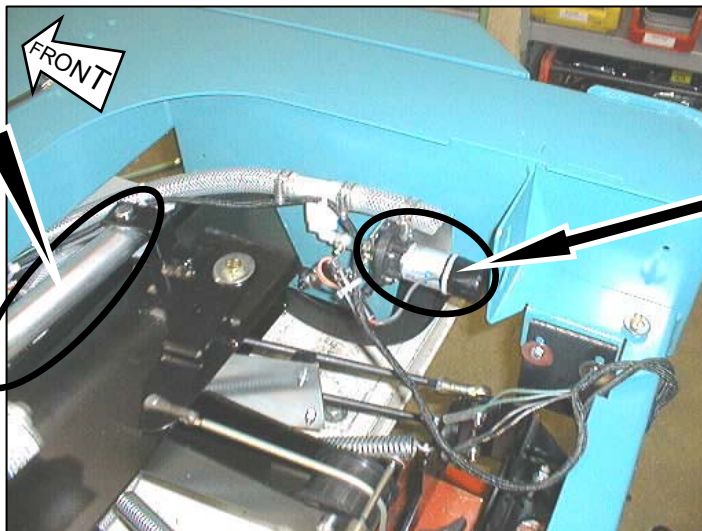



# T15 Component Locator

(page 10 of 10)

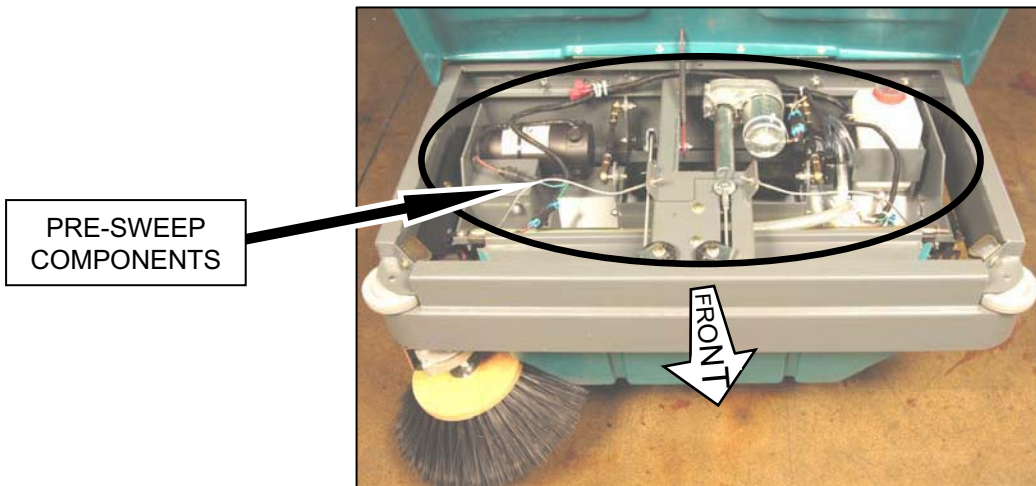
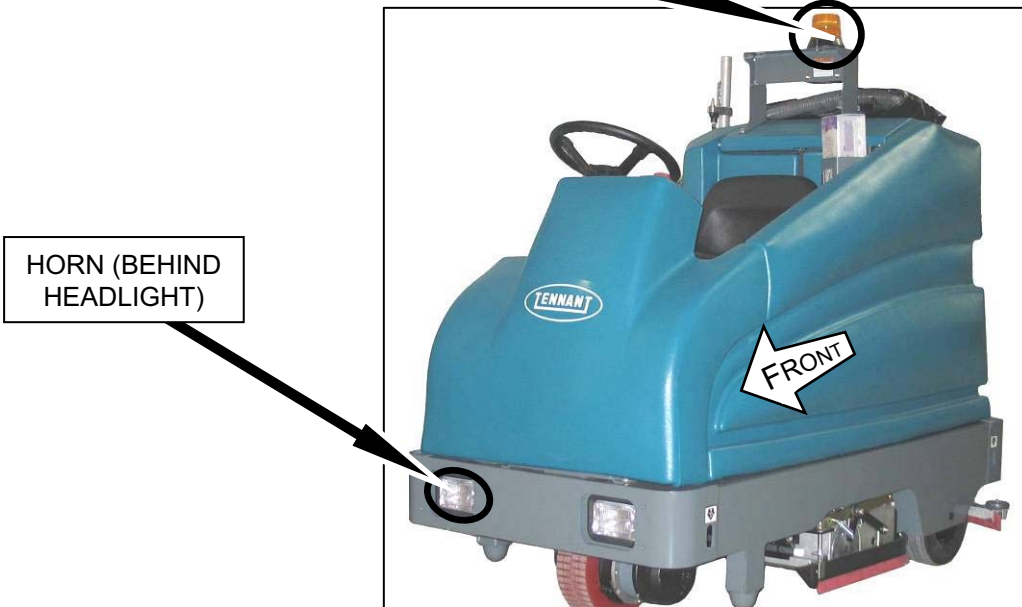
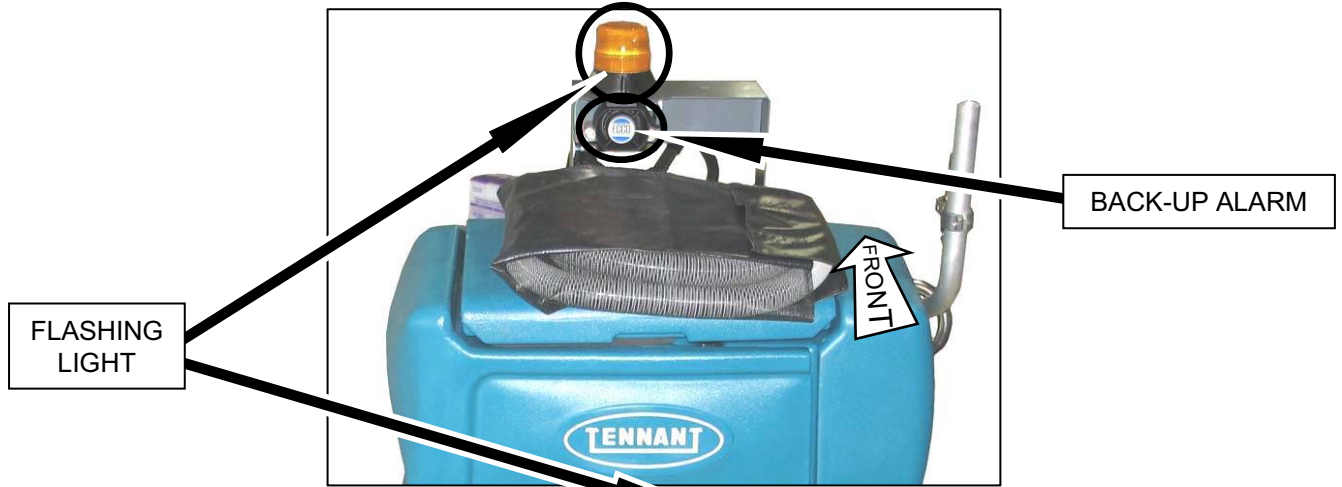

# T15 Specifications

(page 1 of 3)



## GENERAL MACHINE DIMENSIONS/CAPACITIES

Item	Dimension/capacity
Length	1830 mm (72 in)
Length (with Pre-Sweep)	2465 mm (97 in)
Width (less squeegee)	1025 mm (40.25 in)
Width (with squeegee)	1155 mm (45.5 in)
Height	1360 mm (53.5 in)
Height with overhead guard	2030 mm (80 in)
Disk brush diameter for side brush (option)	460 mm (18 in)
Disk brush diameter for Pre-Sweep (option)	380 mm (15 in)
Disk brush diameter for 700 mm (28 in) scrub head	355 mm (14 in)
Disk brush diameter for 900 mm (36 in) scrub head	460 mm (18 in)
Cylindrical sweep brush diameter for Pre-Sweep (option)	155 mm (6 in)
Cylindrical sweep brush length for Pre-Sweep (option)	810 mm (32 in)
Cylindrical scrub brush diameter	155 mm (6 in)
Cylindrical brush length for 700 mm (28 in) scrub head	700 mm (28 in)
Cylindrical brush length for 900 mm (36 in) scrub head	900 mm (36 in)
Squeegee width for 700 mm (28 in) scrub head	950 mm (37.5 in)
Squeegee width for 900 mm (36 in) scrub head	1155 mm (45.5 in)
Scrubbing path width for 700 mm (28 in) scrub head	710 mm (28 in)
Scrubbing path width for 900 mm (36 in) scrub head	915 mm (36 in)
Solution tank capacity	170 L (45 gallons)
Recovery tank capacity	210 L (55 gallons)
GVWR	1134 Kg (2500 lbs)

## GENERAL MACHINE PERFORMANCE

Item	Measure
Aisle turnaround width	2080 mm (82 in)
Aisle turnaround width (with Pre-Sweep)	2770 mm (109 in)
Travel Speed	9.6 Km (6 mph)
Maximum rated climb and descent angle for transport	8° @ gross weight
Maximum rated climb and descent angle for scrubbing	4°
Maximum rated climb and descent angle for trailering	11°

# T15 Specifications

(page 2 of 3)



## POWER TYPE

Type	Quantity	Volts	Ah Rating	Weight
Batteries	6	6	235 @ 20 hr rate	30 kg (67 lb)
	6	6	335 @ 20 hr rate	47 kg (104 lb)

Type	Use	VDC	kW (hp)
Electric Motors	Pre-Sweep brush (disk)	36	0.20 (0.25)
	Pre-Sweep brush (cyl)	36	0.45 (0.60)
	Scrub brush (disk)	36	0.55 (0.75)
	Scrub brush (cylindrical)	36	0.55 (0.75)
	Vacuum fan	36	0.6 (0.8)
	Propelling	36	1.1 (1.5)

Type	VDC	amp	Hz	Phase	VAC
Chargers (Smart)	36	21	45-65	1	85-265

## TIRES

Location	Type	Size
Front (1)	Solid	100 mm wide x 305 mm OD (4 in wide x 12 in OD)
Rear (2)	Solid	90 mm wide x 305 mm OD (3.5 in wide x 12 in OD)

## FaST SYSTEM

Item	Measure
Solution pump	36 Volt DC, 5A, 5.7 LPM (1.5 GPM) open flow, 45 psi bypass setting
Solution flow rate	1.1 LPM (0.30 GPM)
Detergent to water dilution ratio	1:1000
Detergent flow rate	1.14 CC/Minute (0.038 Ounces/Minute)

# T15 Specifications

(page 3 of 3)

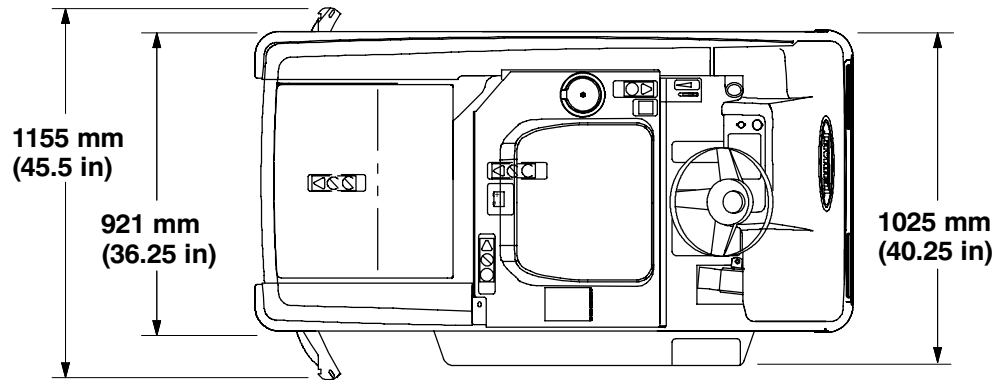

TOP VIEW

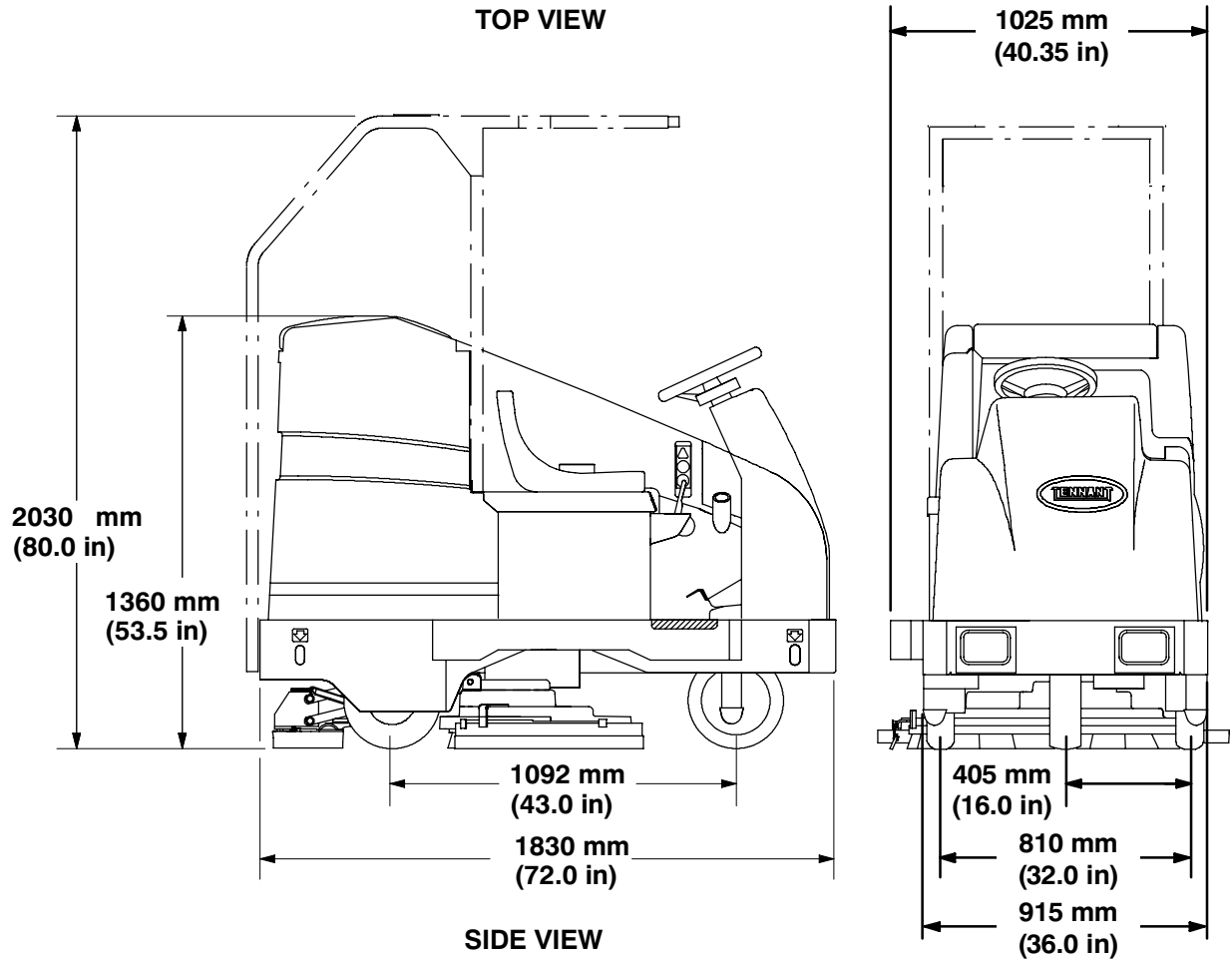

SIDE VIEW

FRONT VIEW

## MACHINE DIMENSIONS

350790

# T15 Basic Troubleshooting

(Page 1 of 2)



Problem	Cause	Remedy
Poor sweeping performance	Worn brush bristles	Replace brushes
	Sweeping brushes not adjusted	Adjust brushes
	Hopper full	Empty hopper
	Hopper skirts worn or damaged	Replace skirts
	Brush drive failure	Check with TENNANT representative for advice
Trailing water – poor or no water pickup	Worn squeegee blades	Rotate or replace squeegee blades
	Squeegee out of adjustment	Adjust squeegee
	Vacuum hose clogged	Flush vacuum hoses
	Vacuum fan inlet filter dirty	Clean inlet filter
	Debris caught on squeegee	Remove debris
	Vacuum hose to squeegee or recovery tank disconnected or damaged	Reconnect or replace vacuum hose
	Tank cover not completely closed	Check for obstructions
	Torn seals on recovery tank	Replace seals
Vacuum fan will not turn on	Recovery tank full	Drain recovery tank
	Foam filling recovery tank	Empty recovery tank
		Use less or change detergent
		Use a defoamer
Vacuum fan circuit breaker tripped	Reset circuit breaker	
Little or no solution flow to the floor	Solution tank empty	Fill solution tank
	Solution control rod broken or out of adjustment	Replace and/or adjust rod
	Solution flow turned off	Turn solution flow on
	Solution supply lines plugged	Flush solution supply lines
	Solution solenoid clogged or stuck	Clean or replace
	ES mode (option): ES switch off	Turn ES switch on
Poor scrubbing performance	Debris caught on scrub brushes	Remove debris
	Improper detergent or brush used	Check with TENNANT representative for advice
	Worn scrub brush(es)	Replace scrub brush(es)
	Scrub brush motor circuit breaker(s) tripped	Reset circuit breaker(s)
		Reduce scrub brush down pressure
		Uneven brush pressure, level scrub head
		Broken brush drive belts on cylindrical scrub head, replace belt
	Check with TENNANT representative for advice	
Low battery charge	Charge batteries until the charger automatically turns off	

# T15 Basic Troubleshooting

(Page 2 of 2)



Problem	Cause	Remedy
FaST System does not operate	FaST switch is turned off	Turn on the FaST switch.
	FaST circuit breaker tripped	Determine cause and reset the 15A circuit breaker button
	Clogged FaST PAK supply hose and/or connector	Soak connector and hose in warm water and clean
	FaST PAK carton is empty or not connected	Replace FaST PAK carton and/or connect supply hose
	FaST system is not primed	To prime, operate the FaST solution system for 5 to 10 minutes.
	Clogged flow control orifice/screen	Remove and clean orifice/screen
	Faulty pump	Contact Tennant representative
	Clogged filter screen	Drain solution tank, remove and clean filter screen
	Faulty detergent timer module	Contact Tennant representative



# T15

# MAINTENANCE & REPAIR Information



## BEFORE CONDUCTING TESTS:

- \* Read and Follow ALL Safety Warnings and Precautions as mentioned at the beginning of this manual
- \* Always use an ESD (Electrostatic Discharge) strap when working near the Control Board
- \* Be cautious when working near Control Board – Battery voltage is always present, even with Key OFF
- \* Always unhook Battery when removing or replacing components

## DURING TESTS:

- \* Call Technical Services if Diagnostic Time Exceeds One Hour With Unknown Cause or Course of Action

**NOTE:** Troubleshooting charts may be shown with optional equipment. The optional equipment may not be specified in these charts. Some machines may not be equipped with all components shown.

# T15 Maintenance & Repair

## Maintenance Checkpoints

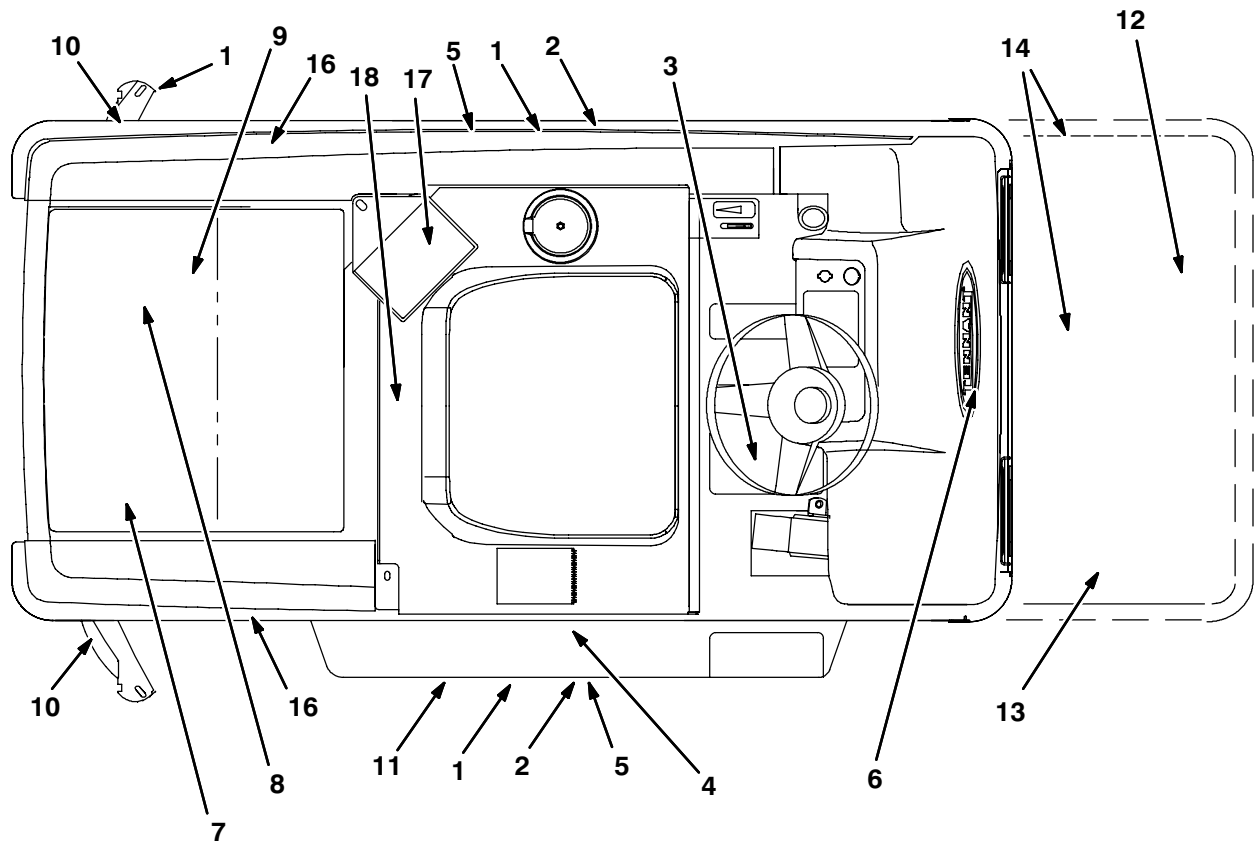

350790



# T15 Maintenance & Repair

## Maintenance Chart

Interval	Key	Description	Procedure	Lubricant/ Fluid	No. of Service Points
Daily	1	Side and rear squeegees	Check for damage and wear	-	3
	2	Scrub brushes	Check for damage, wear, debris	-	2
	8	Recovery tank	Clean tank	-	1
	8	Recovery tank, ES mode	Clean ES filter	-	1
	7	Solution tank, ES mode	Clean solution supply filter	-	1
	9	Vacuum fan inlet filter	Clean	-	1
	-	Machine	Check for leaks	-	3
	11	Cylindrical brushes only: debris trough	Clean	-	1
	12	Pre-Sweep brushes	Check for damage and wear	-	2
	12	Pre-Sweep debris hopper	Clean	-	1
	17	FaST PAK supply hose and connector	Clean and connect hose to storing plug when not in use	-	1
50 Hours	15	Pre-Sweep cylindrical brushes	Check taper	-	1
	5	Cylindrical scrub brushes	Check taper and rotate front to rear	-	2
	10	Squeegee caster wheels and pivot points	Lubricate	SPL	4
	4	Battery cells	Check electrolyte level	DW	3
	1	Side and rear squeegees	Check deflection and leveling	-	6
	14	Pre-Sweep skirts and seals	Check for damage and wear	-	4
	18	FaST/Solution filter screen	Clean	-	1
100 Hours	5	Cylindrical scrub brush drive belts	Check tension and wear	-	2
	13	Pre-Sweep brush drive belts	Check tension and wear	-	2
	3	Steering caster pivot bearing	Lubricate	SPL	1
200 Hours	4	Battery terminals and cables	■Check and clean	-	12
	6	Steering gear chain	Lubricate	GL	1
500 Hours	9	Vacuum fan motor(s)	Check motor brushes	-	1
		Steering gear chain	■Check deflection	-	1
1000 Hours	5	Brush drive motors	Check motor brushes	-	2 (4)
	6	Propelling motor	Check motor brushes	-	1
	16	Rear wheel nuts	■Torque wheel nuts	-	3

### LUBRICANT/FLUID

DW . . . . Distilled water

SPL . . . Special lubricant, Lubriplate EMB grease (TENNANT part no. 01433-1)

GL . . . . SAE 90 weight gear lubricant

*NOTE: Also check procedures indicated (■) after the first 50 hours of operation.*



# T15 Maintenance & Repair

---

## LUBRICATION

---

### STEERING CASTER PIVOT BEARING

The steering caster bearing is located on the floorplate. Lubricate with Lubriplate EMB grease (TENNANT part no. 01433-1) every 100 hours.

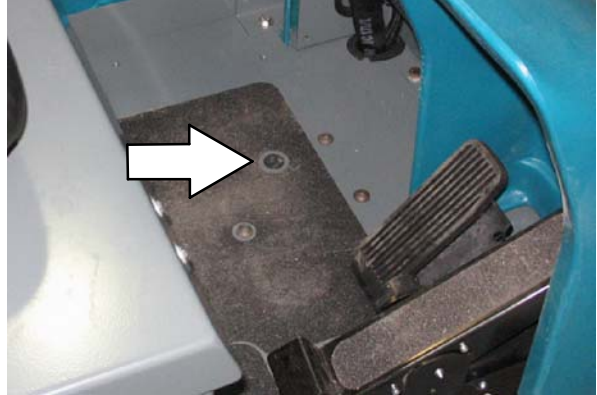

### REAR SQUEEGEE CASTERS

The rear squeegee casters are located on the back side of the rear squeegee. The rear squeegee casters each have two grease fittings. Lubricate the pivot point and caster bearing on each squeegee caster with Lubriplate EMB grease (TENNANT part no. 01433-1) every 50 hours.

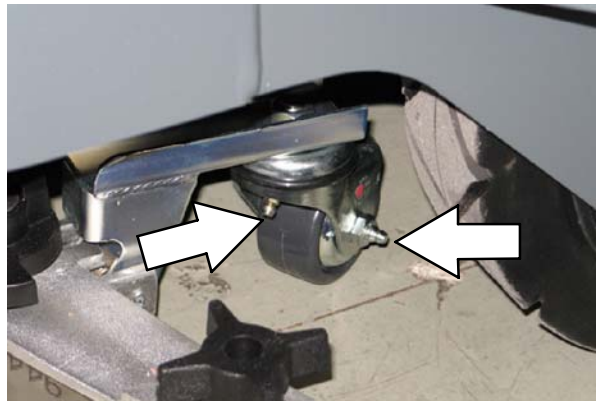

### STEERING GEAR CHAIN

The steering gear chain is located directly above the front tire.

Lubricate with SAE 90 weight gear lubricant every 200 hours of use.

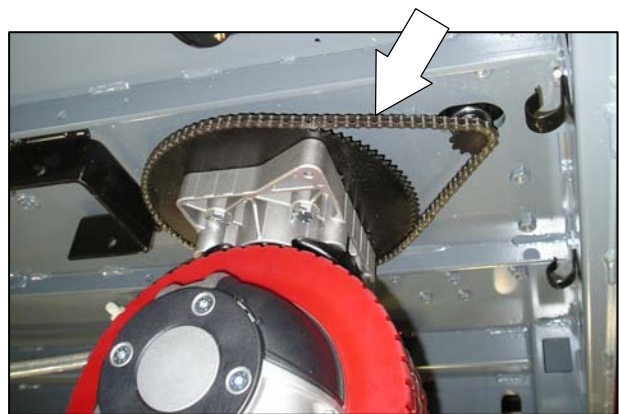

# T15 Maintenance & Repair

---

## BATTERIES

---

The batteries are designed to hold their power for long periods of time. The lifetime of the batteries is limited to number of charges the batteries receive. To get the most life from the batteries, recharge them immediately when the battery discharge indicator begins to blink.

After every 200 hours of use check for loose battery connections and clean the surface of the batteries, including terminals and cable clamps, using a strong solution of baking soda and water. Brush the solution sparingly over the battery tops. Do not allow any baking soda solution to enter the batteries. Use a wire brush to clean the terminal posts and the cable connectors. Wipe off all cleaning solution residue. After cleaning, apply a coating of clear battery post protectant to the terminals and the cable connectors. Keep the tops of the batteries clean and dry.

Objects made of metal can potentially short circuit the batteries. Keep all metallic objects off the batteries. Replace any worn or damaged wires.

Check the electrolyte level in each battery cell before and after charging, and after every 50 hours of operation. Do not charge the batteries unless the fluid is slightly above the battery plates. If needed, add just enough distilled water to cover the plates. Never add acid to the batteries. Do not overfill. Always keep the battery caps on, except when adding water or taking hydrometer readings.

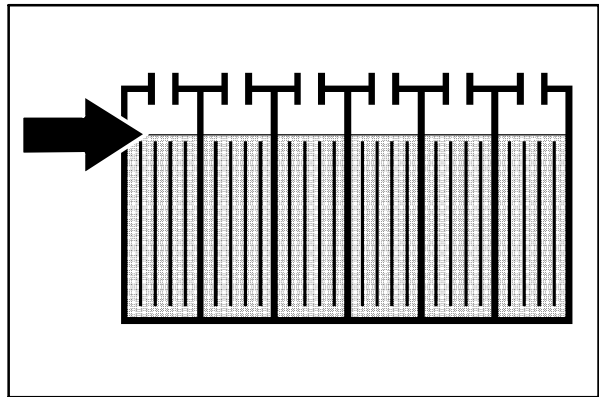

# T15 Maintenance & Repair

Using a hydrometer, measure the specific gravity to determine the charge level and condition of the batteries. If one or more of the battery cells test lower than the other battery cells (0.050 or more), the cell is damaged, shorted, or is near failure. Completely recharge the batteries, then retest them.

*NOTE: Do not take readings immediately after adding distilled water. If the water and acid are not thoroughly mixed, the readings may not be accurate. Check the hydrometer readings against the following chart to determine the remaining battery charge level:*

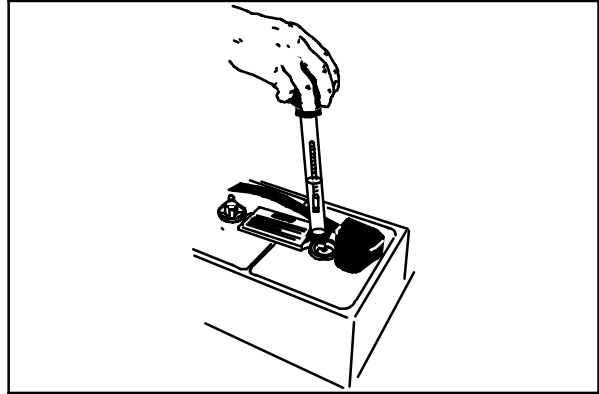

04380

SPECIFIC GRAVITY at 27° C (80° F)	BATTERY CHARGE
1.265	100% Charged
1.223	75% Charged
1.185	50% Charged
1.148	25% Charged
1.110	Discharged

*NOTE: If the readings are taken when the battery electrolyte is any temperature other than 27 C (80 F), the reading must be temperature corrected. Add or subtract to the specific gravity reading 0.004, 4 points, for each 6 C (10 F) above or below 27 C (80 F).*

## CHARGING THE BATTERIES

1. Drive the machine to a flat, dry surface.

*NOTE: Make sure the area is well ventilated.*

2. Turn the machine power off.

**FOR SAFETY: Before leaving or servicing machine, stop on level surface, turn off machine, and remove key.**

3. Lift the operator seat to access the batteries. The support arm automatically engages when the seat is lifted all the way up.

4. Check the water level in all battery cells.



# T15 Maintenance & Repair

If the level is low, add just enough distilled water to cover the plates. DO NOT OVERFILL. The batteries can overflow during charging due to expansion.

*NOTE: Make sure the battery caps are in place while charging.*

**FOR SAFETY: When maintaining or servicing machine, avoid contact with battery acid.**

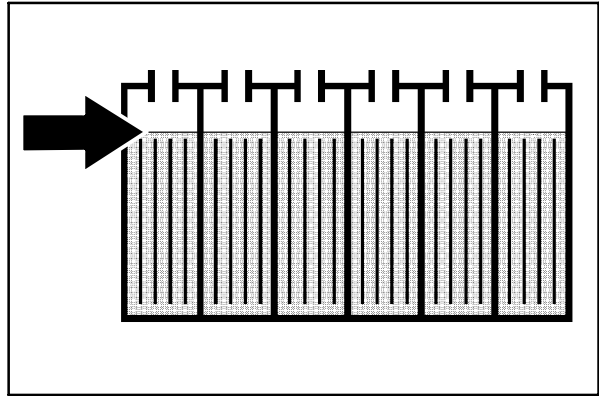

5. Unplug the machine connector from the batteries.



6. Plug the charger connector into the battery connector.

 **WARNING: Batteries emit hydrogen gas. Explosion or fire can result. Keep sparks and open flame away. Keep covers open when charging.**

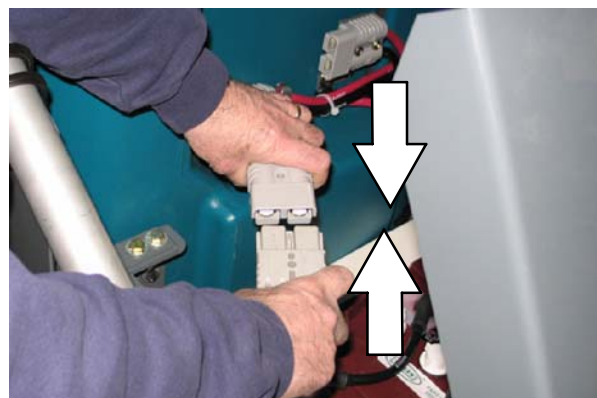

# T15 Maintenance & Repair

7. Plug the battery charger into the wall outlet.

*NOTE: Refer to the instructions provided by the charger manufacturer for more detailed information.*

8. The TENNANT charger will start automatically. When the batteries are fully charged, the TENNANT charger will automatically turn off.
9. After the charger has turned off, unplug the charger from the wall outlet.

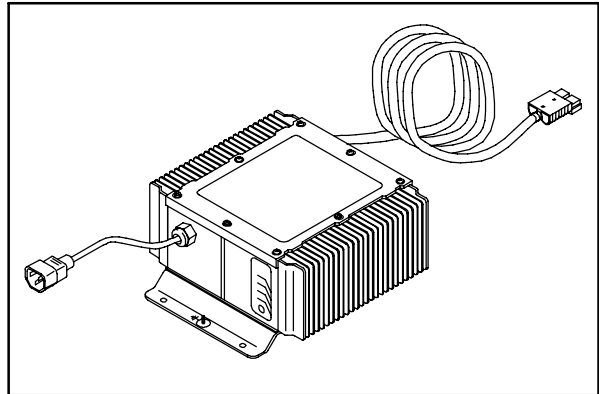

10. Unplug the charger connector from the battery connector on the machine.

**FOR SAFETY: When maintaining or servicing machine, avoid contact with battery acid.**

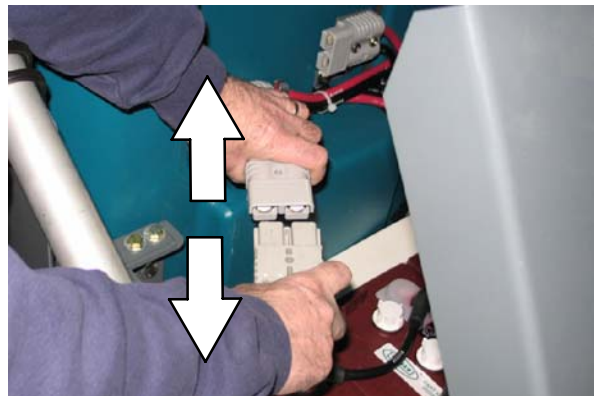

11. Connect the battery connector to the machine connector.
12. Check the electrolyte level in each battery cell after charging. If needed, add distilled water to raise the electrolyte level to about 12 mm (0.40 in) below the bottom of the sight tubes.
13. Lower the seat support by slightly raising it while pushing the support arm inward.



# T15 Maintenance & Repair

## TO REPLACE BATTERIES

1. Drive the machine to a flat, dry surface.

*NOTE: Make sure the area is well ventilated.*

2. Turn the machine power off.

**FOR SAFETY: Before Leaving Or Servicing Machine; Stop On Level Surface, turn key switch OFF.**

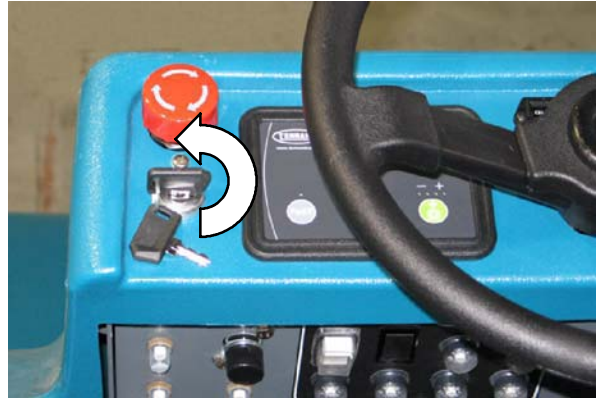

3. Lift the operator seat to access the batteries. The support arm automatically engages when the seat is lifted all the way up.



4. Un-plug the battery connector from in front of the solution tank.

**FOR SAFETY: Disconnect Battery Connections Before Working On machine.**

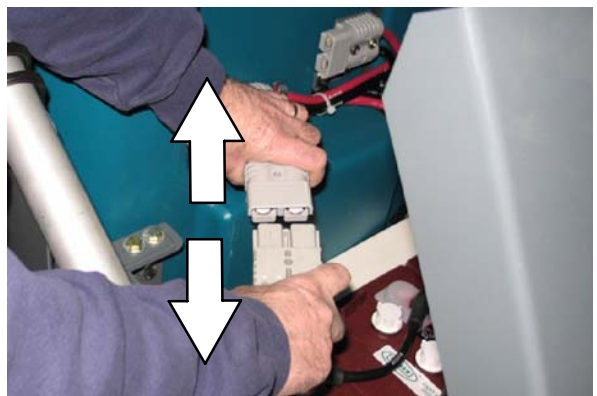

# T15 Maintenance & Repair

5. Pull the rubber battery cable boots back to access the cable end nuts.



6. Remove all of the battery cables.
7. Use the built-in straps to lift and remove each battery.
8. Use a solution of baking soda and water to clean the battery compartment area.

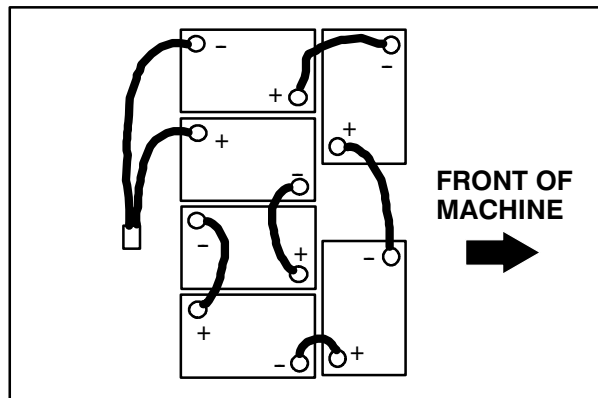

9. Install the new batteries in the same orientation as the old batteries.
10. Reconnect all of the battery cables.
11. Check the batteries and charge if necessary. See TO CHARGE BATTERIES instructions.

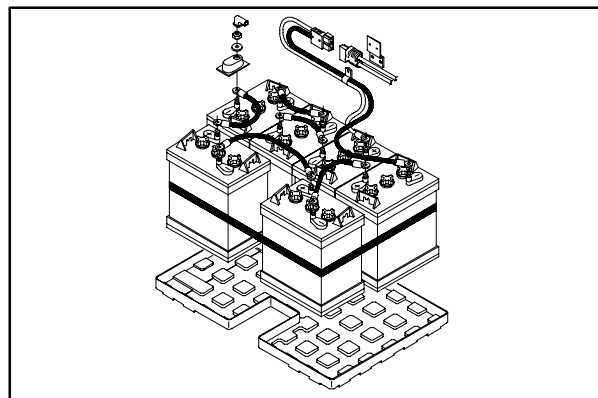

12. Reconnect the battery connector at the front of the solution tank.



13. Lower the seat support and operate the machine. Check for proper operation.





# T15 Maintenance & Repair

---

## CONTROL PANEL

---

The control panel houses the directional controller, relays, contactors, and fuses. These components can be accessed by pivoting the control panel mount plate down against the seat support.

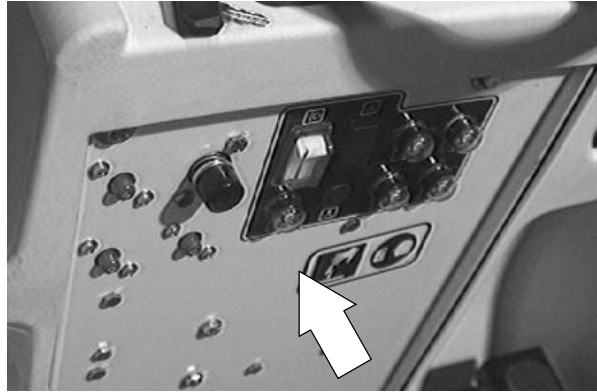

## TO ACCESS CONTROL PANEL

**FOR SAFETY: Before Leaving Or Servicing Machine; Stop On Level Surface, turn key switch OFF.**

1. Lift the operator seat to access the batteries. The support arm automatically engages when the seat is lifted all the way up.



2. Un-plug the battery connector from in front of the solution tank.

**FOR SAFETY: Disconnect Battery Connections Before Working On machine.**

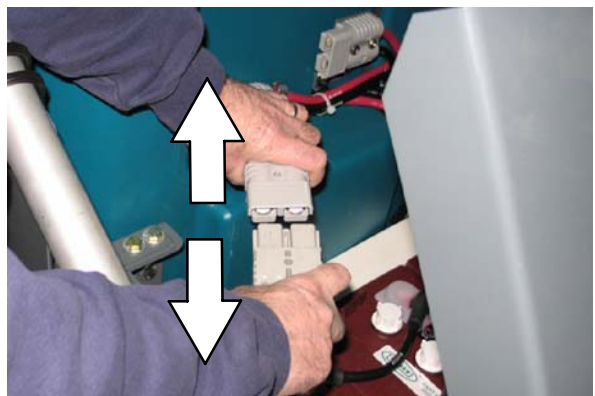

# T15 Maintenance & Repair

3. Lower the seat support.



4. Remove the two screws at the top of the control panel mount plate.

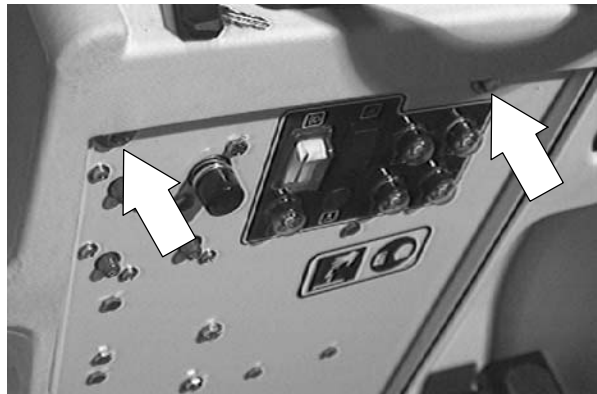

5. Pivot the mount plate down until it is resting against the seat support.

M

# T15 Maintenance & Repair

---

## INSTRUMENT PANEL

---

The instrument panel consists of a touch panel, circuit board, switches, and circuit breakers. The touch panel controls various machine functions. The indicator lights keep the operator informed on machine performance.



### TO REPLACE TOUCH PANEL

**FOR SAFETY: Before Leaving Or Servicing Machine; Stop On Level Surface, turn key switch OFF.**

1. Open the control panel. See TO ACCESS CONTROL PANEL instructions.

**FOR SAFETY: Disconnect Battery Connections Before Working On machine.**

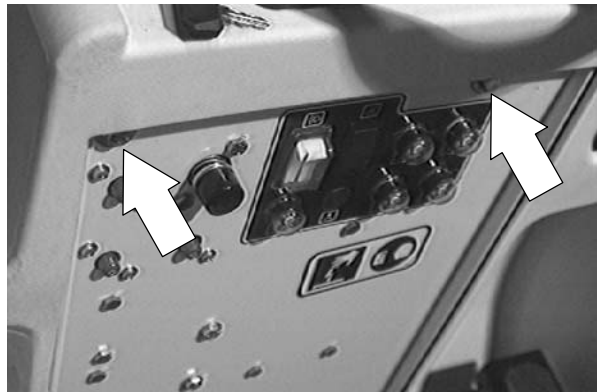

2. Locate the circuit board cover on the inside, front wall of the steering support, behind the control panel.

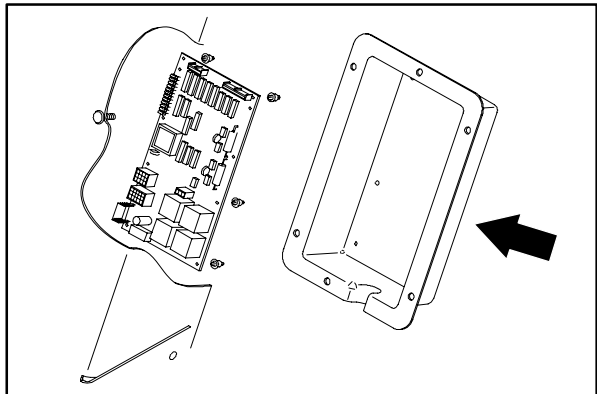

# T15 Maintenance & Repair

3. Remove the six nuts holding the circuit board cover onto the frame.

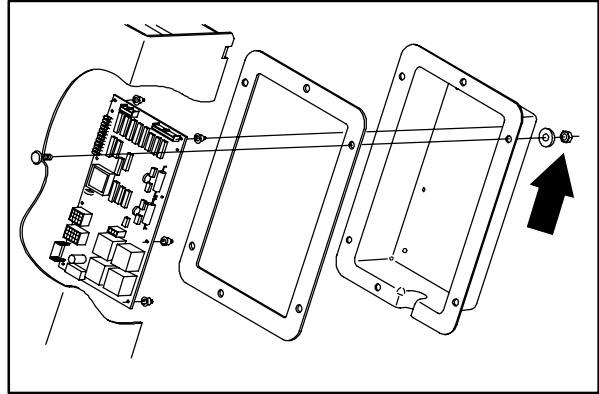

4. Pull the circuit board cover back to access the circuit board.

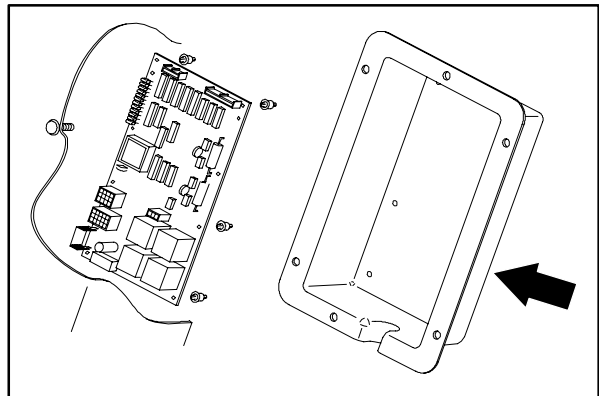

5. Un-plug the two ribbon cables from the circuit board.

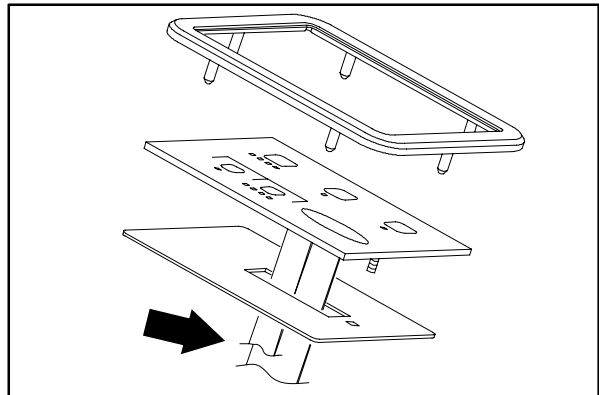

6. Locate the four touch panel lock clips on the under side of the dash panel. Remove the lock clips.

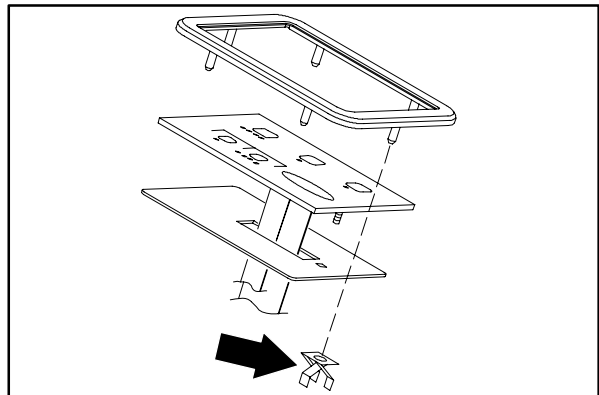

# T15 Maintenance & Repair

7. Pull the touch panel bezel up and remove from the machine.

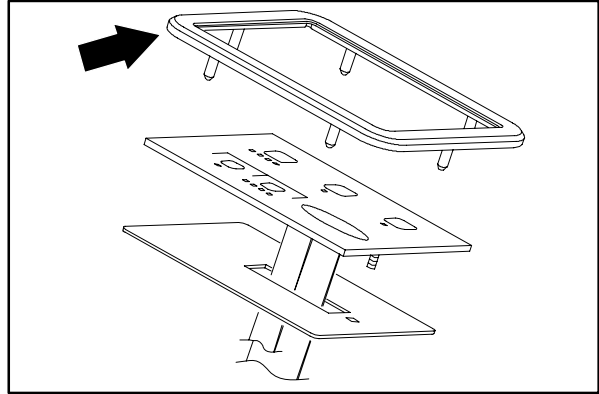

8. Remove the touch panel from the machine.

*NOTE: Be careful when removing the ribbon cables from the slot in the dash panel.*

9. Position the new touch panel on the machine. Route the ribbon cable through the slot in the dash panel.

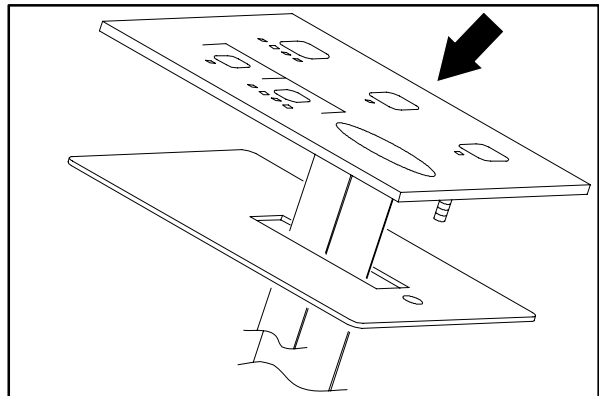

10. Place the touch panel bezel over the touch panel. Line up the posts on the bezel with the mount holes in the dash panel.



11. Install the four lock clips on the bezel posts.

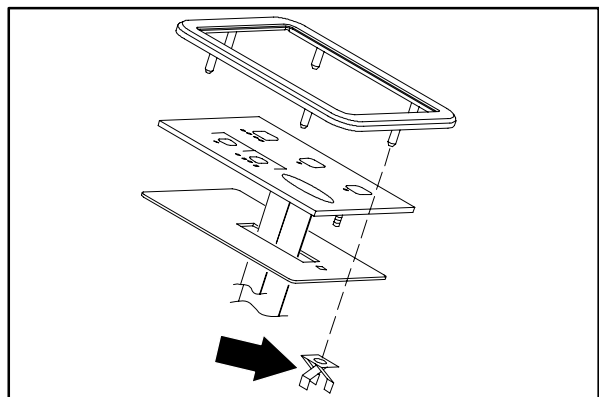

# T15 Maintenance & Repair

12. Connect the ribbon cables to the circuit board.

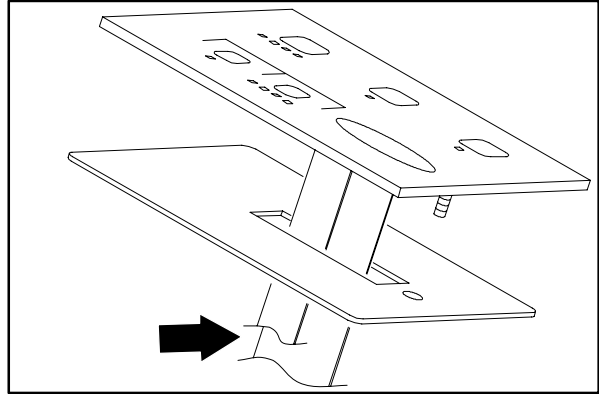

13. Position the circuit board cover back up to the inside, front wall of the steering support, behind the control panel.

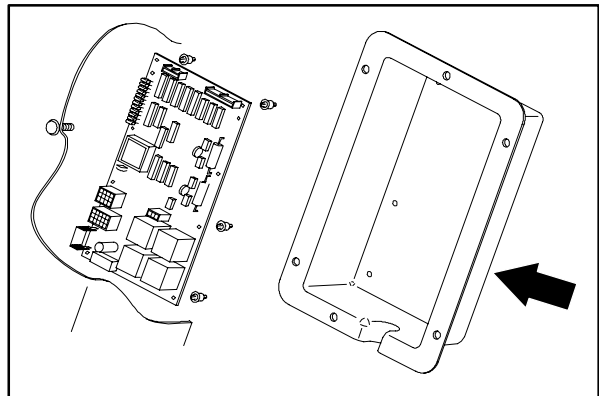

14. Reinstall the six nuts on the circuit breaker cover. Hand tighten lightly.

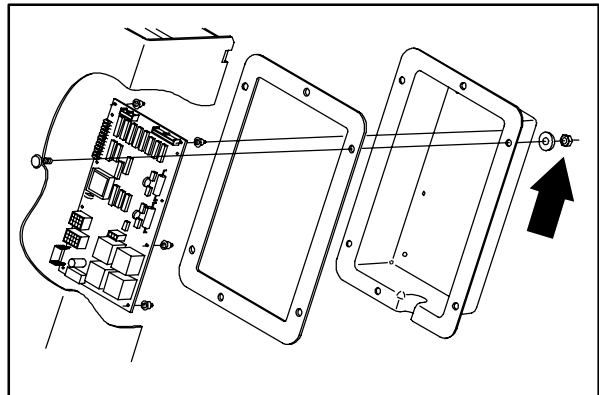

15. Pivot the control panel back in position. Reinstall the two screws and tighten to 18 - 24 Nm (15 - 20 ft lb).

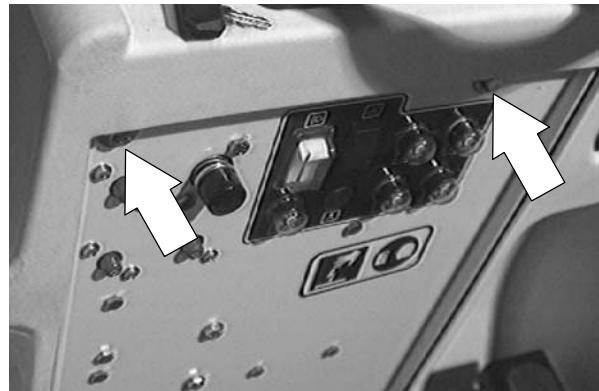

## T15 Maintenance & Repair

16. Lift the operator seat and reconnect the battery connector at the front of the solution tank.



17. Close the seat support. Start the machine and check for proper operation.



# T15 Maintenance & Repair

## TO REPLACE CIRCUIT BOARD

**FOR SAFETY: Before Leaving Or Servicing Machine; Stop On Level Surface, turn key switch OFF.**

1. Open the control panel. See TO ACCESS CONTROL PANEL instructions.

**FOR SAFETY: Disconnect Battery Connections Before Working On machine.**

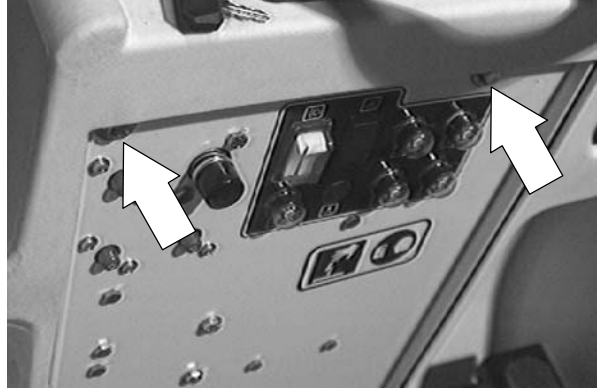

2. Locate the circuit board cover on the inside, front wall of the steering support, behind the control panel.

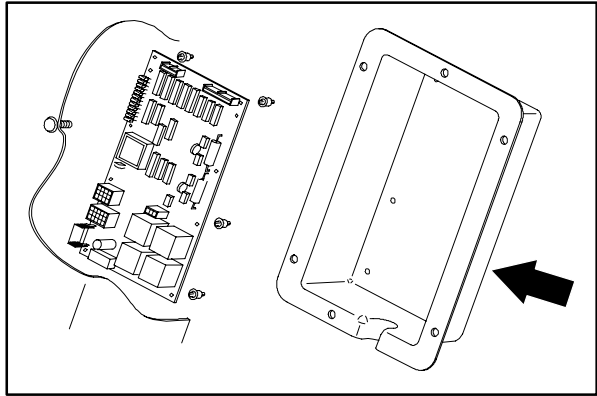

3. Remove the six nuts holding the circuit board cover on the frame.

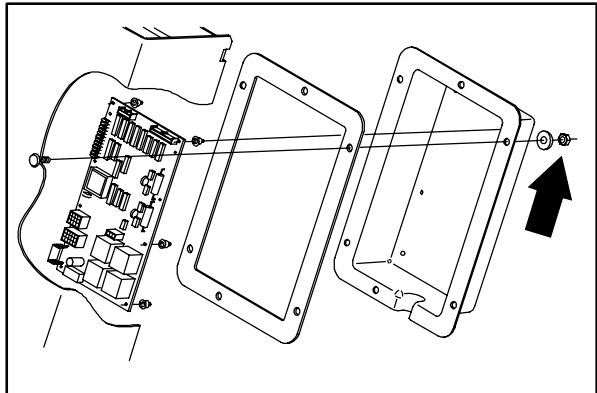



# T15 Maintenance & Repair

4. Pull the circuit board cover back to access the circuit board.

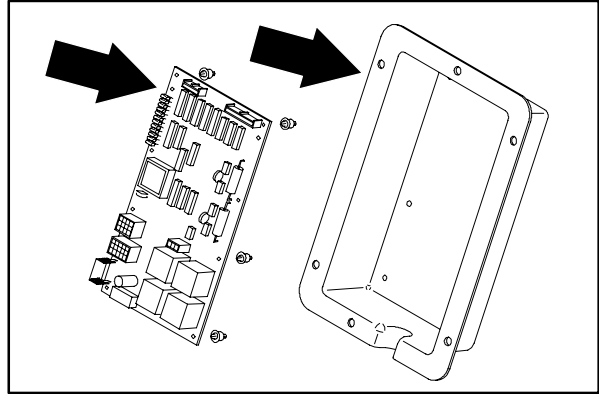

5. Un-plug the two ribbon cables from the circuit board.

6. Un-plug the three wire connectors from the circuit board.

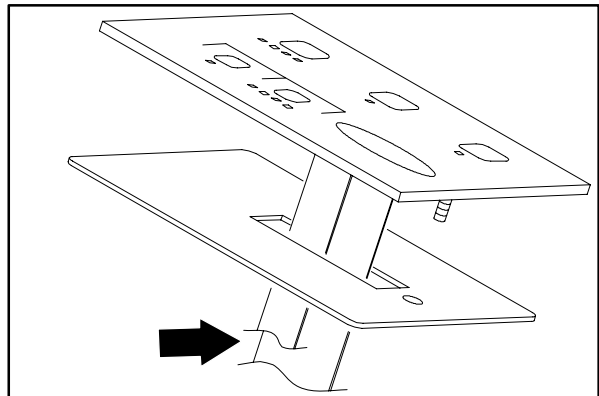

7. Pop the circuit board off the six plastic stand-offs. Remove the circuit board from the machine. Note the orientation of the circuit board.

8. Position the new circuit board on the six plastic stand-offs. Gently push the board down until the stand-off snaps in place.

9. Reconnect the three wire connectors and two ribbon cables to the new circuit board. See schematic in this section.

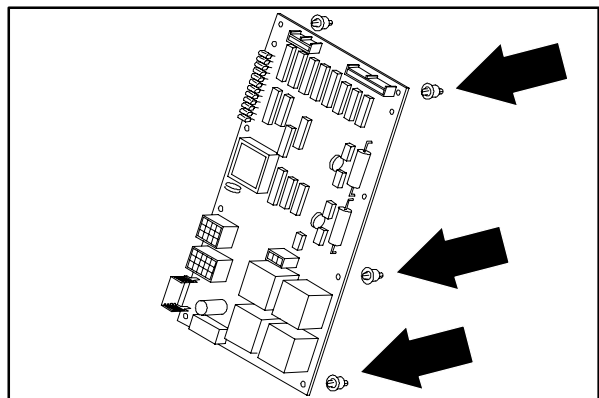

10. Position the circuit board cover back up to the inside, front wall of the steering support, behind the control panel.

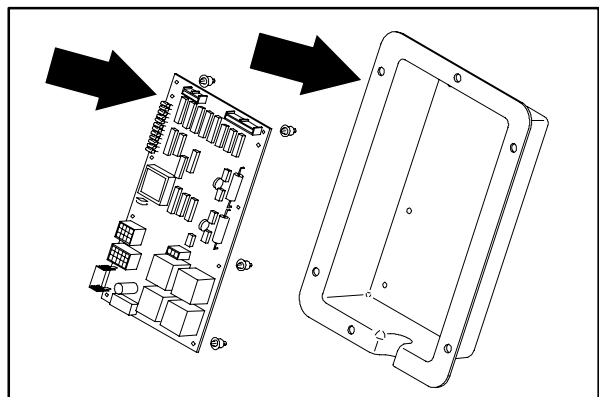

# T15 Maintenance & Repair

11. Reinstall the six nuts on the circuit board cover. Hand tighten lightly.

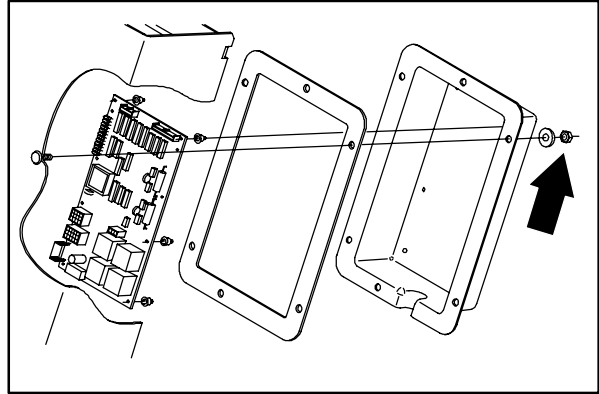

12. Pivot the control panel back in position. Reinstall the two screws and tighten to 18 - 24 Nm (15 - 20 ft lb).

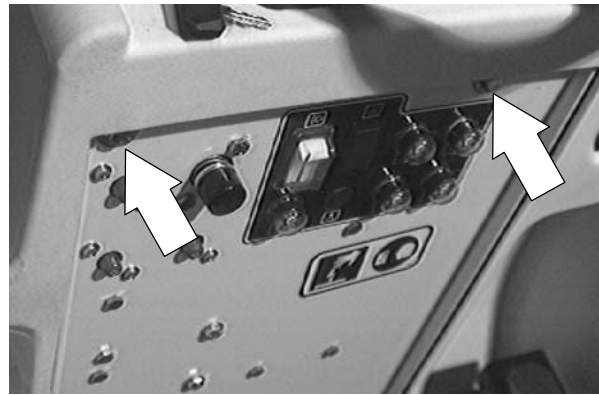

13. Lift the operator seat and reconnect the battery connector at the front of the solution tank.



14. Close the seat support. Start the machine and check for proper operation.



# T15 Maintenance & Repair

---

## CIRCUIT BREAKERS

---

### RESETABLE CIRCUIT BREAKERS

Circuit breakers are resettable electrical circuit protection devices designed to stop the flow of current in the event of a circuit overload. Once a circuit breaker is tripped, reset it manually by pressing the reset button after the breaker has cooled down.

If the overload that caused the circuit breaker to trip is still present, the circuit breaker will continue to stop current flow until the problem is corrected.

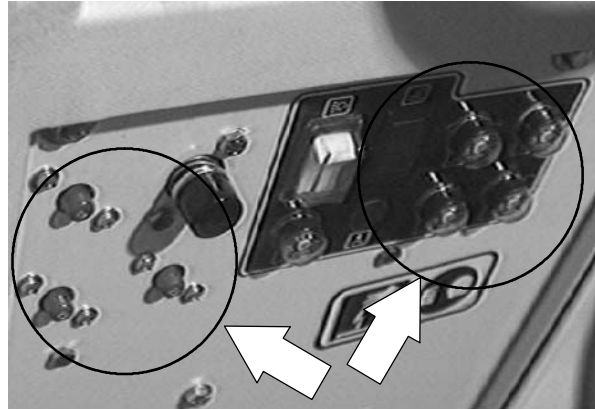

The circuit breakers are located on the operator console.

The chart below shows the circuit breakers and the electrical components they protect.

Circuit breaker	Rating	Circuit protected
CB1	10 A	Machine Power
CB2	10 A	Battery Discharge Indicator
CB3	15 A	Operating Lights
CB4	10 A	Sweep Head Actuator, Back-up Alarm, Power Wand
CB5	10 A	Horn
CB6	15 A	Machine Control Board, Touch Panel, Side Brush
CB7	20 A	Single Vacuum Fan
	40 A	Dual Vacuum Fans
CB8	25 A	Right (disk) or Front (cylindrical) Scrub Brush Motor
CB9	25 A	Left (disk) or Rear (cylindrical) Scrub Brush Motor
CB10	25 A	Pre-Sweep System
CB11	10 A	FaST System
CB12	10 A	Pre-Sweep Side Brush(es)

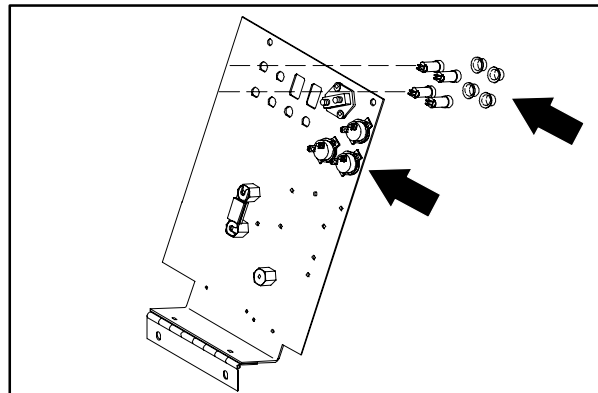

# T15 Maintenance & Repair

## TO REPLACE CIRCUIT BREAKER

**FOR SAFETY: Before Leaving Or Servicing Machine; Stop On Level Surface, turn key switch OFF.**

1. Open the control panel. See TO ACCESS CONTROL PANEL instructions.

**FOR SAFETY: Disconnect Battery Connections Before Working On machine.**

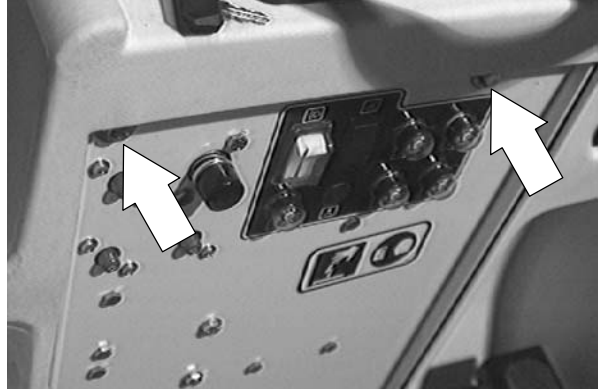

2. Locate the circuit breakers on the upper edge of the control panel.

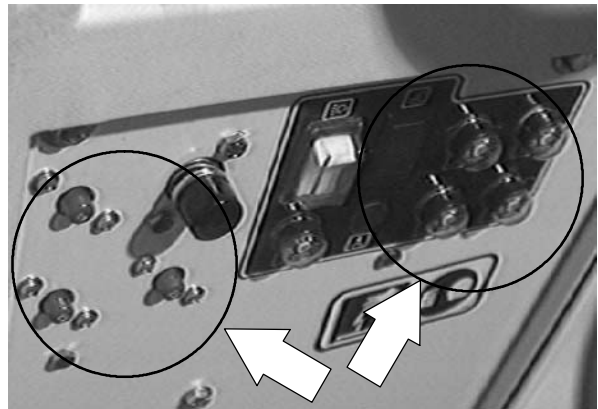

3. Locate the circuit breaker that needs changing.

4. Disconnect the wires from the back of circuit breaker.

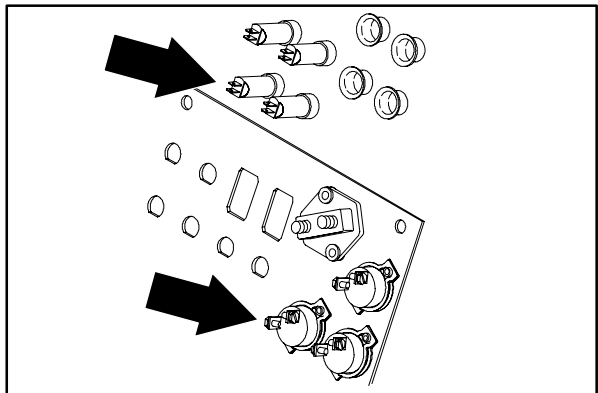

# T15 Maintenance & Repair

5. Remove the metal lock ring from the circuit breaker. The lock ring may have to be cut to remove, or, remove the two screws holding the CB to the panel.

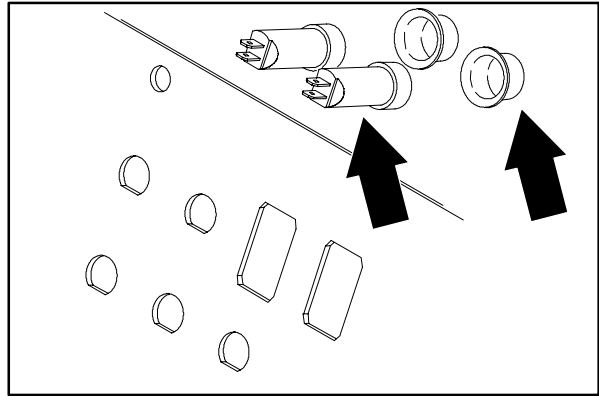

6. Push the circuit breaker out of the mount hole, or, remove the CB from the back of panel.

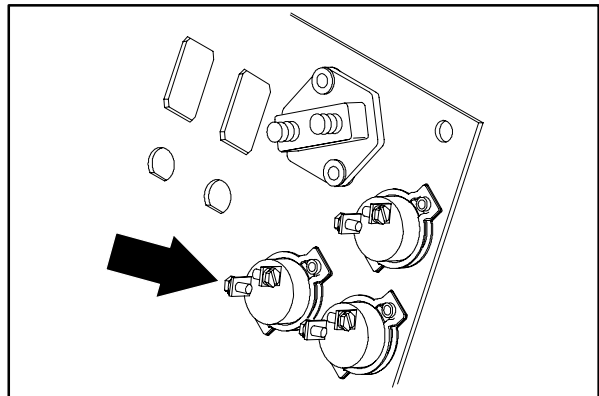

7. Remove the rubber boot from the old circuit breaker and install it on the new circuit breaker. (lower amp only)

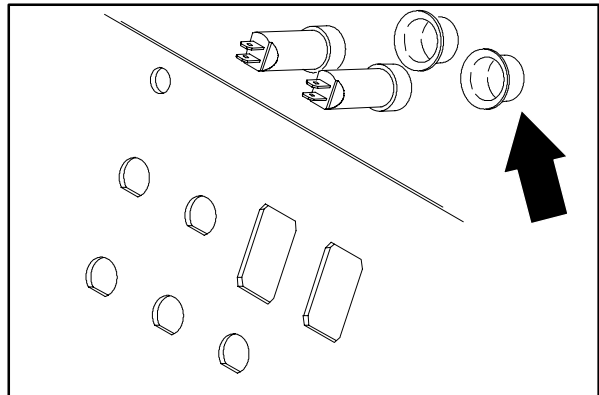

8. Position the new circuit breaker in the mount hole. Note that the circuit breaker and mount hole are "D" shaped. The circuit breaker can only be installed one way. (lower amp only)

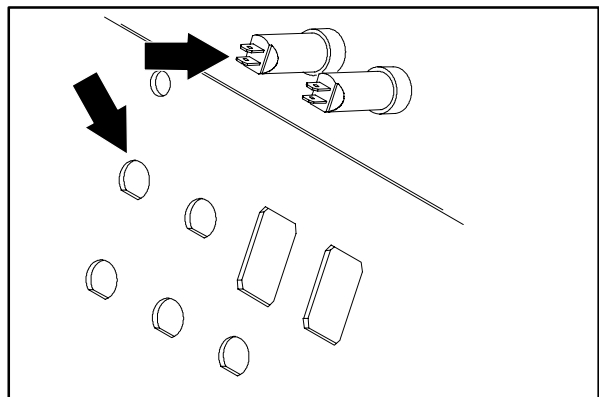

# T15 Maintenance & Repair

9. Install the new lock ring on the new circuit breaker, or, reinstall the two screws. Hand tighten.
10. Reconnect the wires to the back of the new circuit breaker. See the schematic in this section.

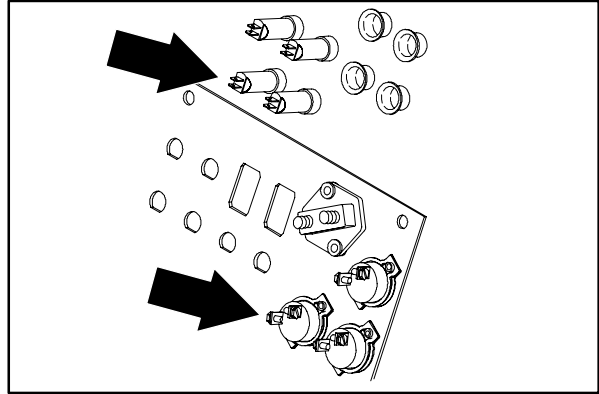

11. Pivot the control panel back in position. Reinstall the two screws and tighten to 18 - 24 Nm (15 - 20 ft lb).

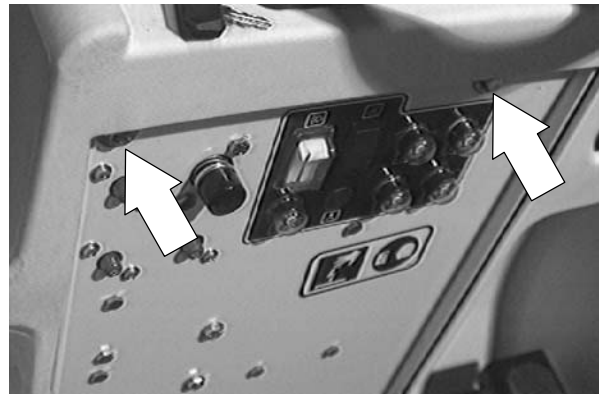

12. Lift the operator seat and reconnect the battery connector at the front of the solution tank.

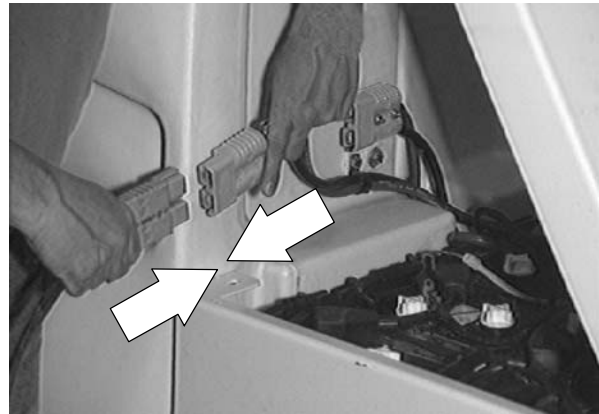

13. Close the seat support. Start the machine and check for proper operation.

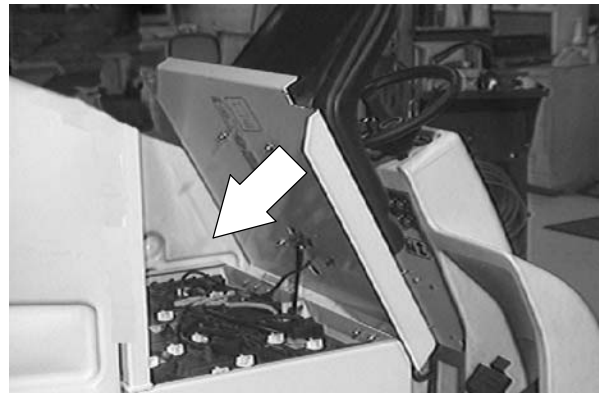

# T15 Maintenance & Repair

## FUSES

The fuse is a one-time protection device designed to stop the flow of current in the event of a circuit overload.

*NOTE: Always replace the fuse with a fuse of the same amperage.*

The fuse is located behind the operator console. Access the fuse by lowering the operator console.

Fuse	Rating	Circuit Protected
FU-1	80 A	Propelling

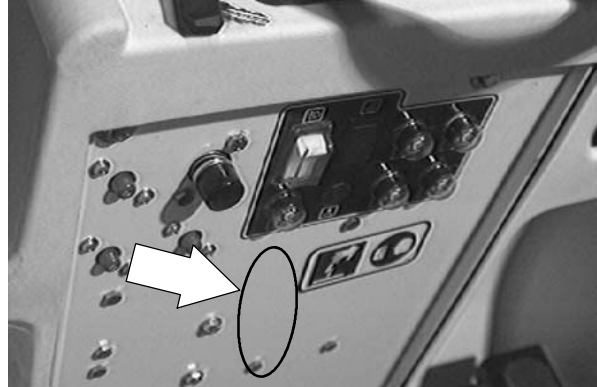

## TO REPLACE FUSE

**FOR SAFETY: Before Leaving Or Servicing Machine; Stop On Level Surface, turn key switch OFF.**

1. Open the control panel. See TO ACCESS CONTROL PANEL instructions.

**FOR SAFETY: Disconnect Battery Connections Before Working On machine.**

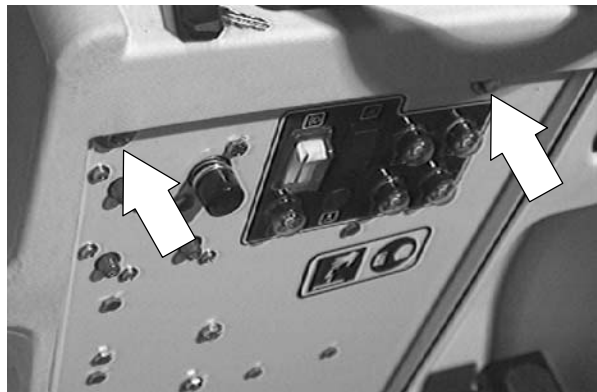

2. Locate the electrical fuse on the bottom, left side of the control panel.

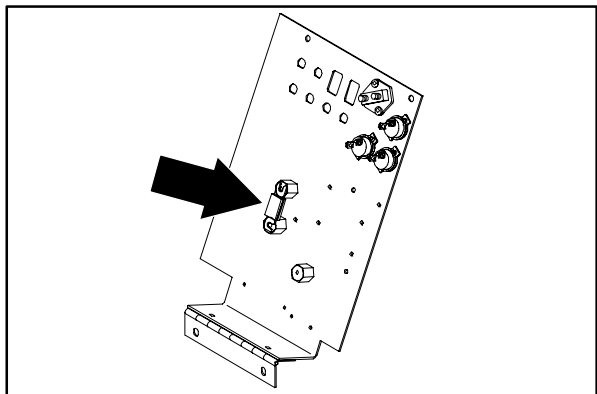

# T15 Maintenance & Repair

3. Loosen both bolts holding the two power cables to the top and bottom of the fuse and red stand-offs.

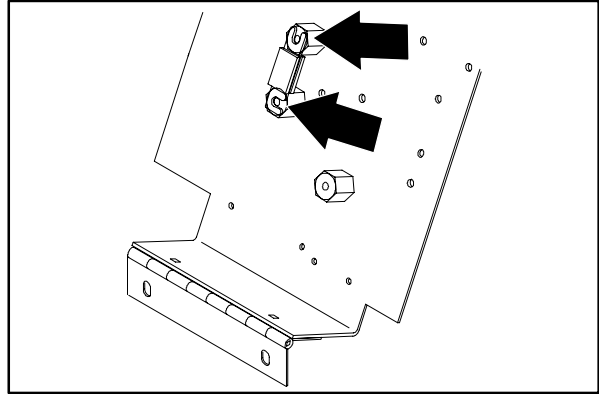

4. The fuse has slots on the top and bottom. Slide the fuse up and to the side and remove.

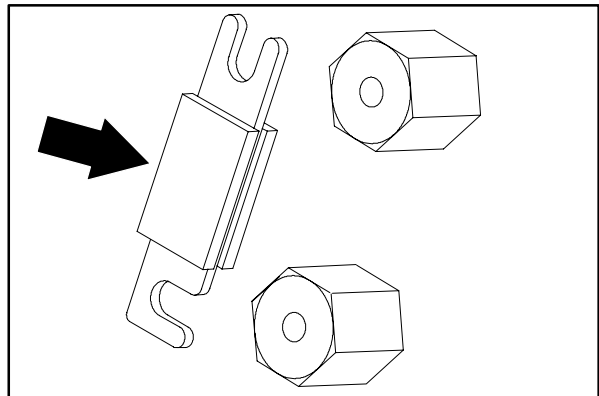

5. Position the new fuse on the two red stand-offs, under the two bolts and power cables. Hand tighten the hardware. See the schematic in this section.

6. Pivot the control panel back in position. Reinstall the two screws and tighten to 18 - 24 Nm (15 - 20 ft lb).

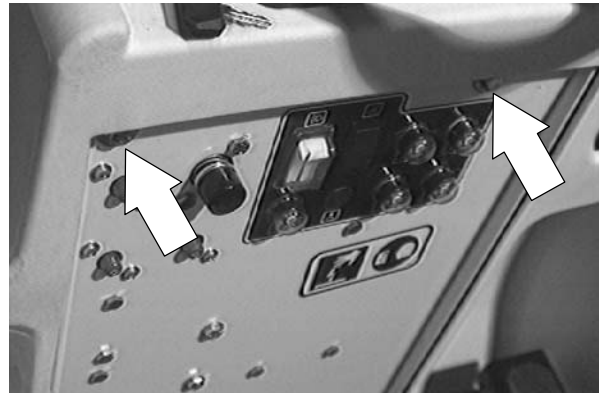

7. Lift the operator seat and reconnect the battery connector at the front of the solution tank.

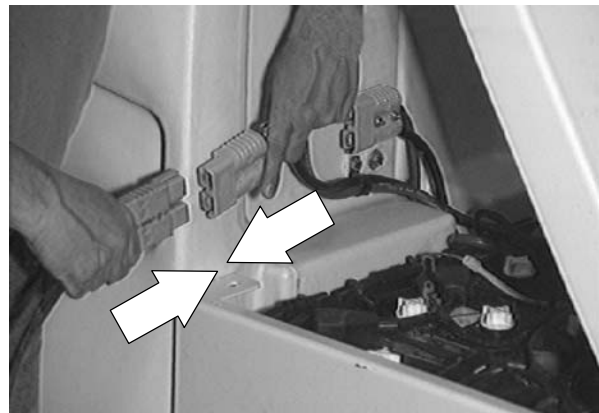

8. Start the machine and check for proper operation.





# T15 Maintenance & Repair

---

## DIRECTIONAL CONTROL PEDAL

---

The directional pedal controls the machine's direction of travel and propelling speed. The machine's speed is controlled by the amount of pressure placed on the pedal; the farther the pedal is pressed, the faster the machine will travel.

When the machine is moving forward and the directional pedal is reversed, the machine will coast for a short distance before changing direction. Use the brake pedal to stop the machine.

**Forward:** Press the top of the directional pedal with the upper part of your foot.

*NOTE: A machine power shut-off switch is located under the operator seat. If there is no weight on the operator seat, the machine WILL NOT propel in any direction.*

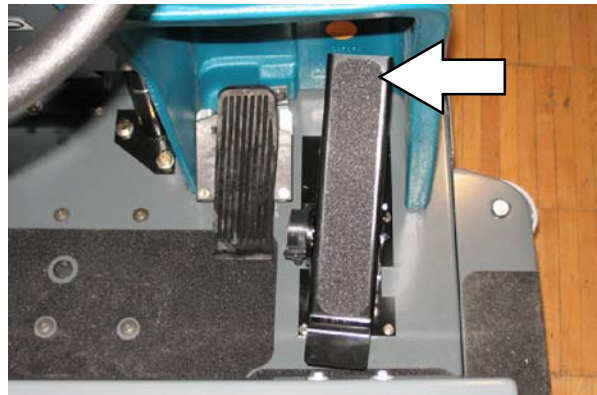

**Reverse:** Press the bottom of the directional pedal with the heel of your foot.

*NOTE: When the directional pedal is placed into the reverse position, the rear squeegee will automatically raise. After a short delay, the vacuum will stop.*

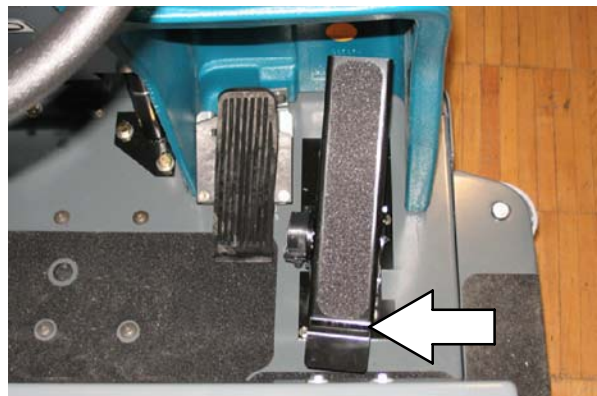

**Neutral:** The machine will automatically return to the Neutral position when you take your foot off of the directional pedal.

*NOTE: When the directional pedal returns to the neutral position the scrub head will stop. After a short delay, the scrub head will also raise.*

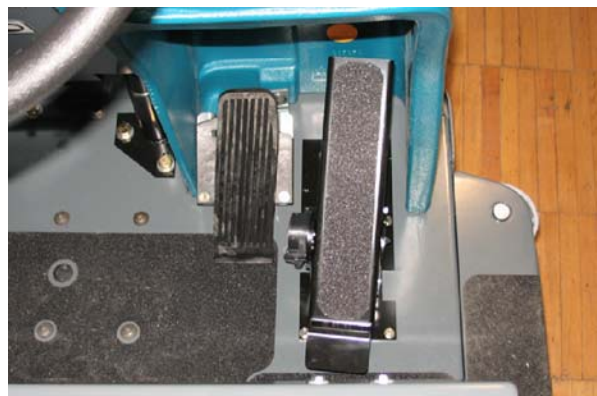

# T15 Maintenance & Repair

## TO REPLACE MOTOR CONTROLLER

**FOR SAFETY: Before Leaving Or Servicing Machine; Stop On Level Surface, turn key switch OFF.**

1. Open the control panel. See TO ACCESS CONTROL PANEL instructions.

**FOR SAFETY: Disconnect Battery Connections Before Working On machine.**

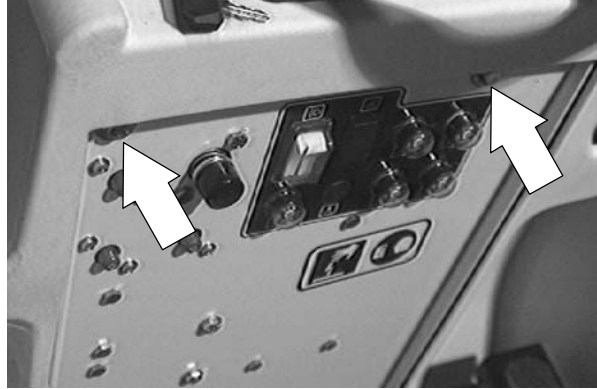

2. Locate the controller box in the center of the control panel.

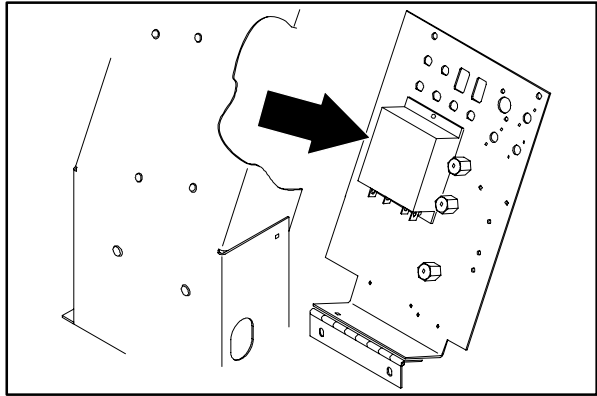

3. Disconnect the wires and power cables leading to the controller.

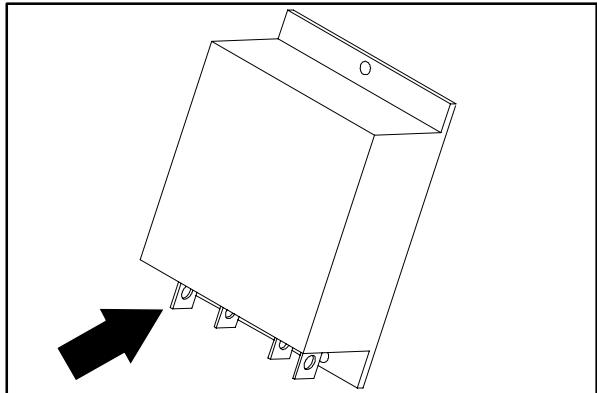

# T15 Maintenance & Repair

4. Remove the three screws and nuts holding the controller to the panel. Remove the controller from the machine.

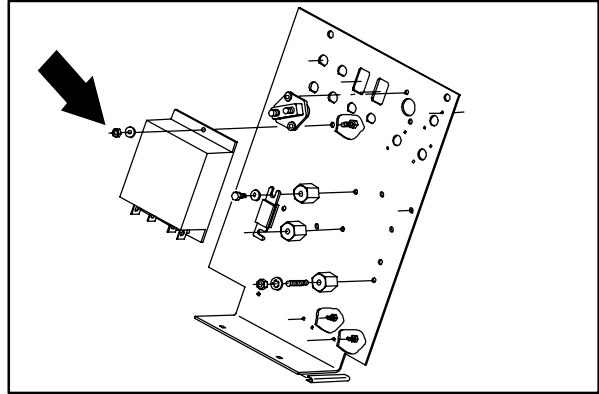

5. Position the new controller on the panel. Reinstall the screws and nuts. Hand tighten.

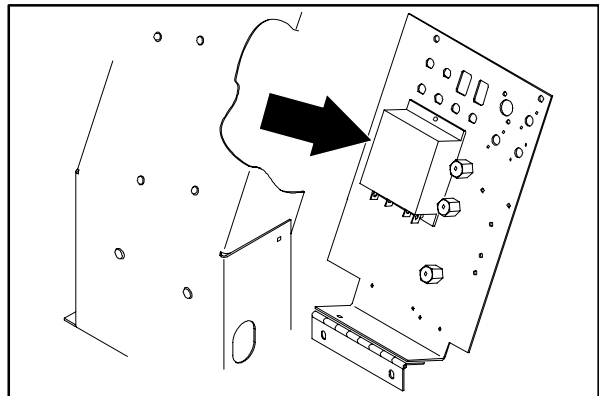

6. Reconnect the power cables and electrical wires to the controller. See the schematic in this section.

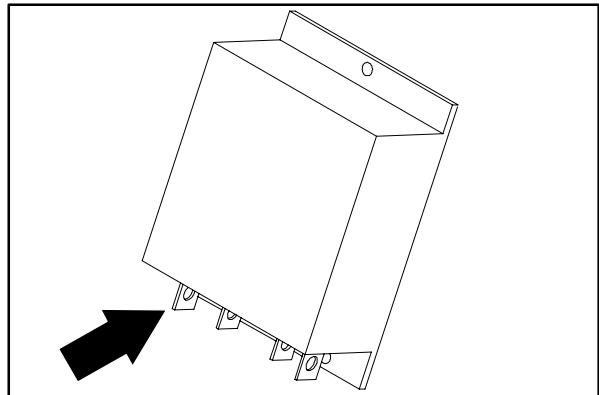

7. Pivot the control panel back in position. Reinstall the two screws and tighten to 18 - 24 Nm (15 - 20 ft lb).

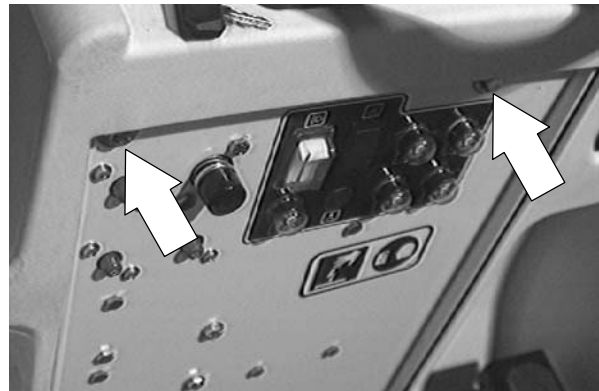

# T15 Maintenance & Repair

8. Lift the operator seat and reconnect the battery connector at the front of the solution tank.

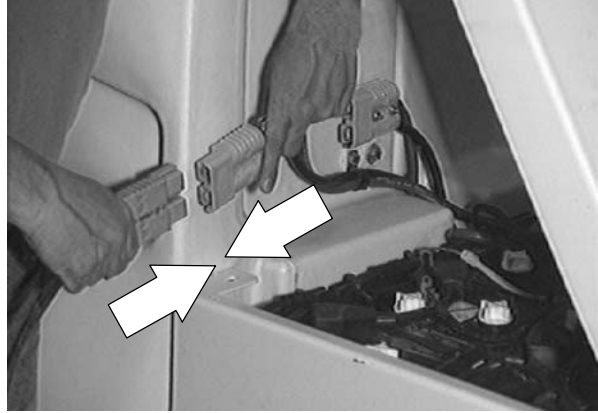

9. Start the machine and check for proper operation of the propelling.



---

## TO REPLACE TAILLIGHT BULB

---

1. Drain the tanks, then remove tank drain caps.
2. Loosen the bottom screws holding the drip tray.
3. Rotate the tray outward from the bottom. This allows access to the taillight assembly.

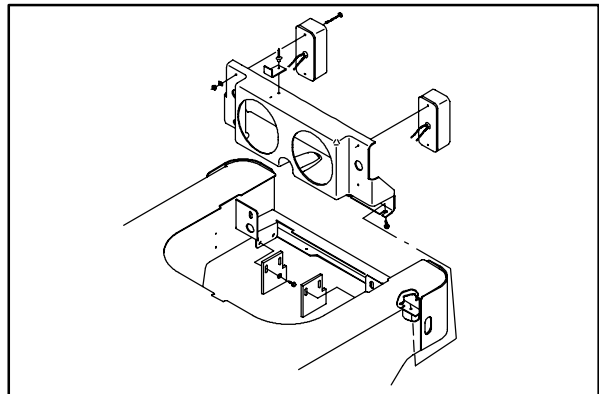

# T15 Maintenance & Repair

---

## SCRUB HEAD

---

The model T15 can be equipped with either a cylindrical or a disc style scrub head. The scrub head houses the scrub brushes and their drive mechanisms.

The scrub head adjustments are factory set and should not be changed unless scrub head parts are damaged or replaced.

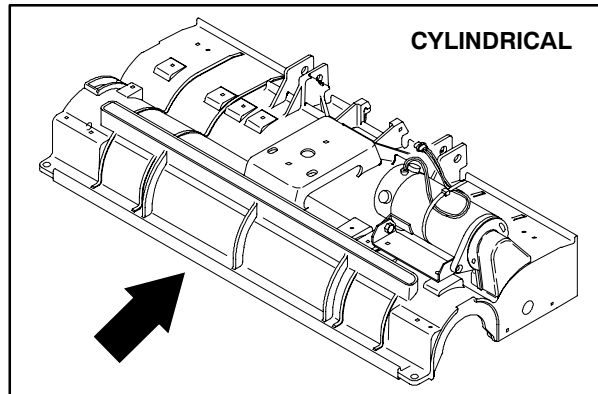

The scrub head also includes floor skirts to control water spray. These skirts can be adjusted and need to be replaced if worn or damaged.

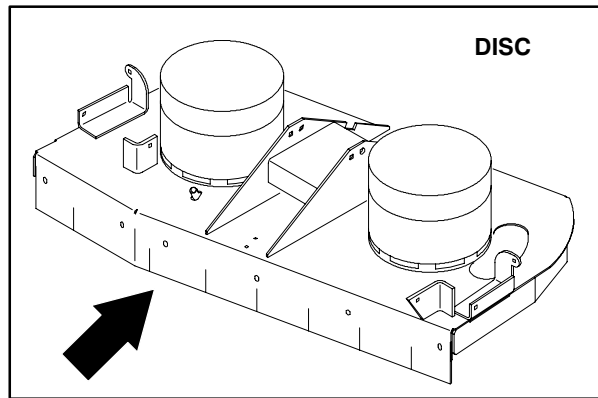

## SCRUB HEAD LINKS

The scrub head links attach the scrub head frame to the machine frame. The two scrub head links allow the scrub head to follow the contour of the floor. The links have a pivot point on each end and no regular lubrication.

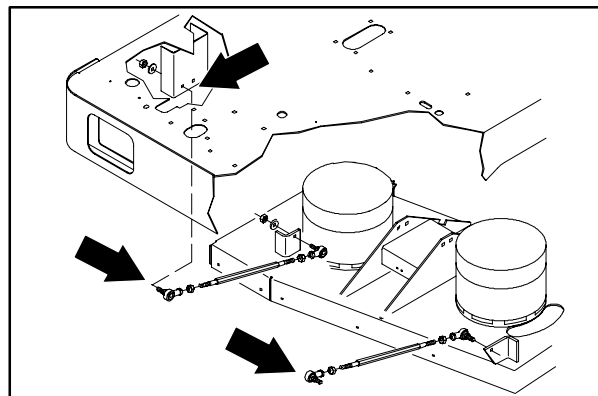

# T15 Maintenance & Repair

## TO REPLACE SCRUB HEAD LINKS

1. Start the machine and lower the scrub head to the floor. Shut off the key.

**FOR SAFETY: Before Leaving Or Servicing Machine; Stop On Level Surface, turn key switch OFF.**



2. Go under the machine on each side and remove the nyloc nut holding the scrub head links to the machine frame and scrub head frame. Remove the scrub head links from the machine.

*NOTE: The measurement for the new scrub head links should be **16 inches** from the center of the front ball joint to the center of the rear balljoint.*

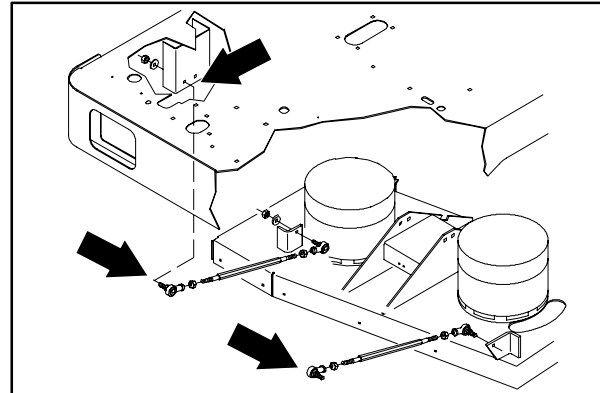

3. Install the new scrub head links on the machine with the ball joints facing the inside of the machine frame. Firmly tighten the four nyloc nuts.

*NOTE: Use the **front** frame hole for the **cylindrical** scrub head and the **rear** frame mount hole for the **disc** scrub head.*

4. Start the machine and raise the scrub head. Check the scrub head links for proper operation.

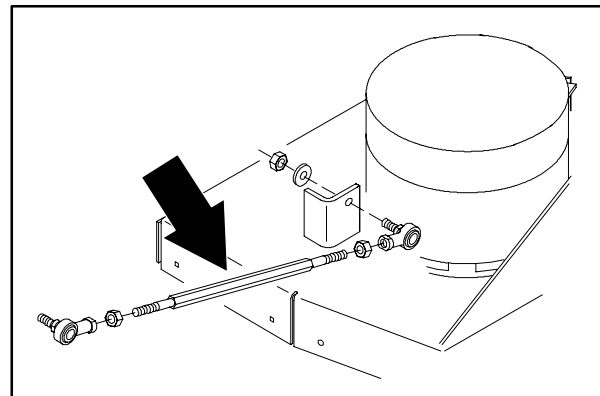

M

# T15 Maintenance & Repair

## TO REMOVE DISC SCRUB HEAD

1. Start the machine and lower the scrub head to the floor. Shut off the key.

**FOR SAFETY: Before Leaving Or Servicing Machine; Stop On Level Surface, turn key switch OFF.**



2. Disconnect the water line leading from the shut-off valve to the scrub head.

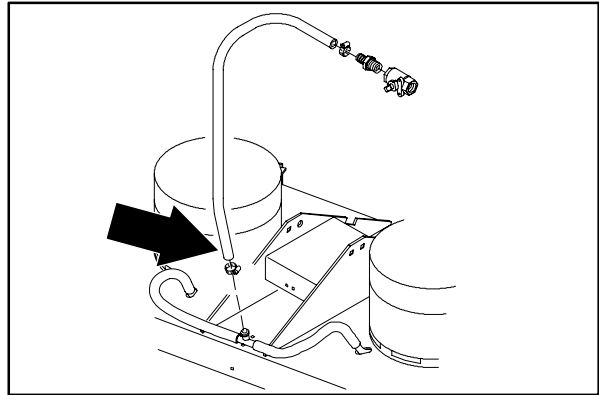

3. Disconnect the two scrub brush motors from the main electrical harness.

*NOTE: Mark the connectors for proper re-assembly.*

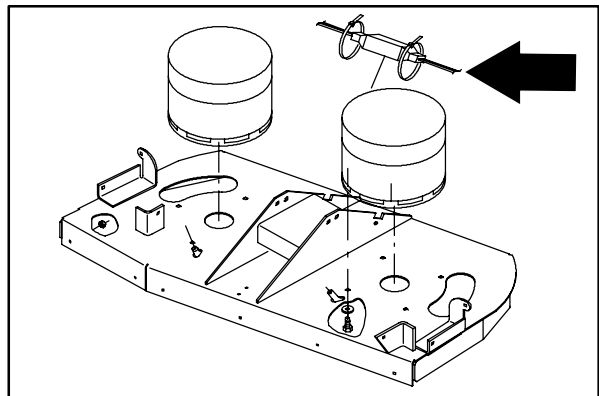

# T15 Maintenance & Repair

4. Remove the cotter pin and clevis pin from the scrub head lift mechanism where it attaches to the frame and actuator.

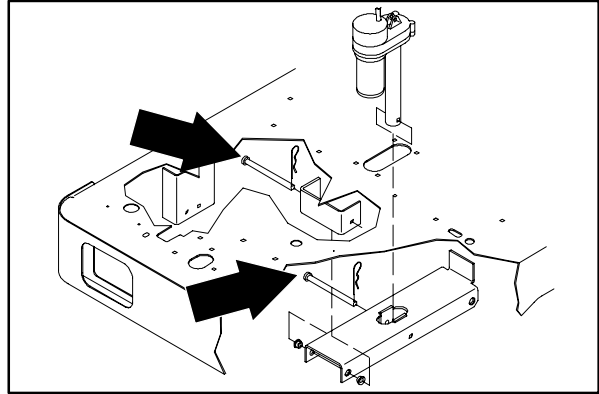

5. Remove the nyloc nut holding the ball joint to the mount bracket on the scrub head. Do this on both sides of the scrub head.
6. Jack up the front of the machine far enough to slide the scrub head out. Install jack stands under the machine frame.
7. The scrub head can now be pulled out from under the machine frame.

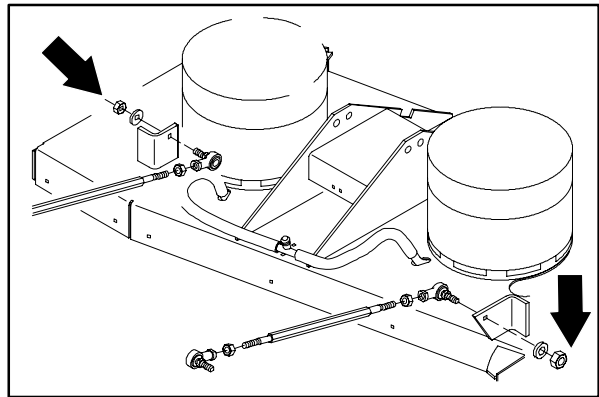



# T15 Maintenance & Repair

## TO INSTALL DISC SCRUB HEAD

**FOR SAFETY: Before Leaving Or Servicing Machine; Stop On Level Surface, turn key switch OFF.**

1. Slide the scrub head under the machine frame with the scrub head link mount holes facing the front.
2. Install the ball joint on the end of the scrub head link into the mount hole on the scrub head. The ball joint should be positioned so it is facing the inside of the machine frame. Do this on both sides of the machine.

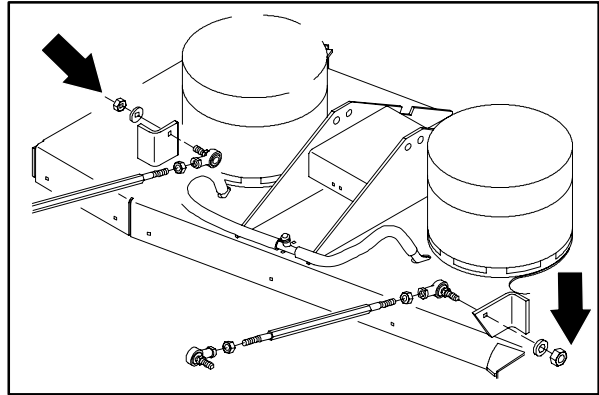

3. Position the scrub head as close as possible to the center. Remove the jack stands and lower the machine until the clevis pins can be reinstalled in the front of the scrub head lift bracket and the bottom of the lift actuator.

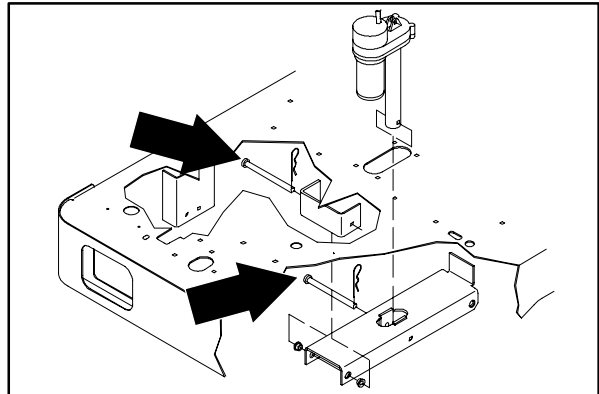

4. Reconnect the brush drive motors to the main electrical harness.

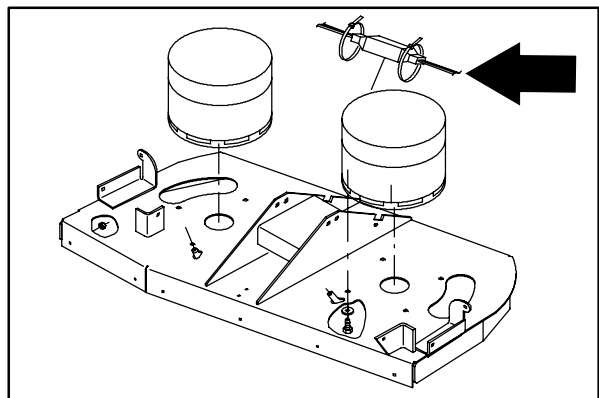

## T15 Maintenance & Repair

5. Reconnect the water line to the scrub head

6. Start the machine and raise the scrub head. Operate the machine and check the scrub head for proper operation. Check the scrub brushes for proper rotation.

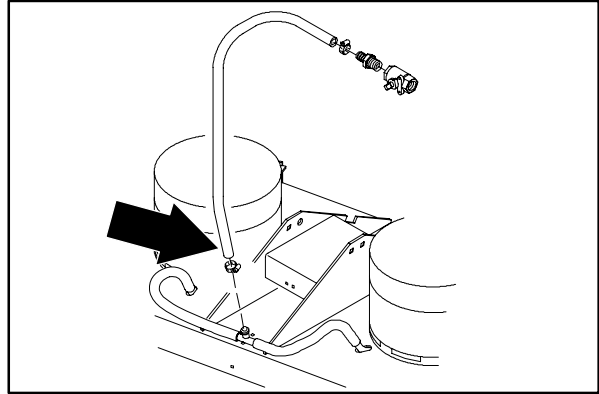

M

# T15 Maintenance & Repair

## TO REPLACE DISC SCRUB HEAD BRUSH MOTOR

**FOR SAFETY: Before Leaving Or Servicing Machine; Stop On Level Surface, turn key switch OFF.**

1. Remove the side squeegees. See TO REPLACE SIDE SQUEEGEE BLADES instructions in the SCRUBBING section.

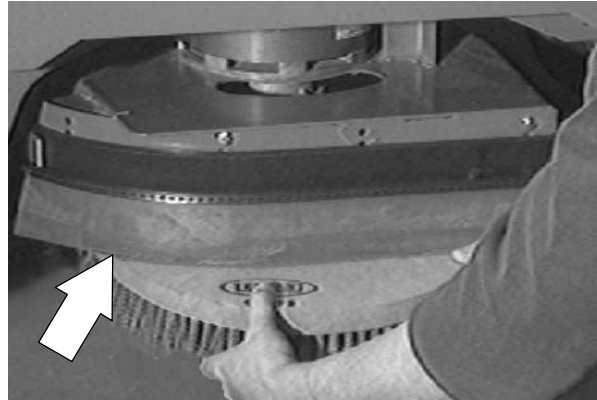

2. Remove the scrub brushes. See TO REPLACE DISC SCRUB BRUSHES instructions in the SCRUBBING section.

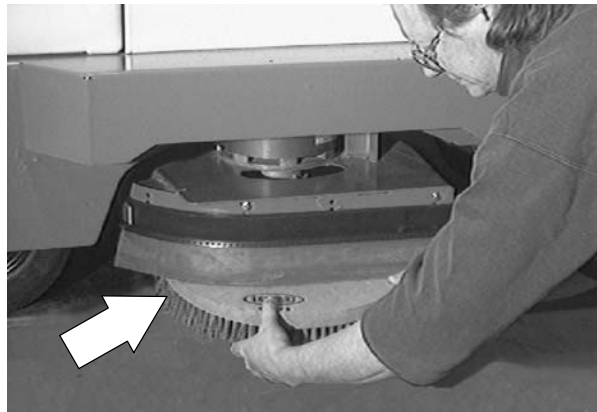

3. Go in under the scrub head and remove the screw and washer from the center of the brush drive plug.
4. Drop the drive plug down off the motor shaft. Make sure to retain the square key.

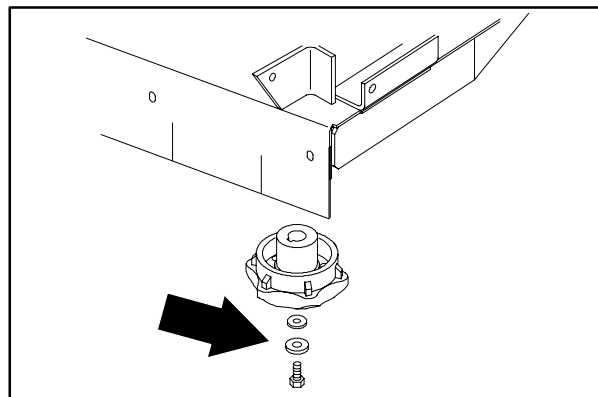

M

# T15 Maintenance & Repair

5. Remove the four screws holding the brush motor to the scrub head.

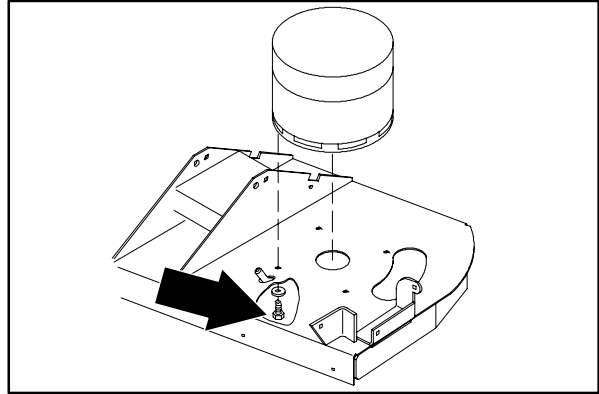

6. Start the machine and lower the scrub head. Shut off the key.



7. Go in on top of the scrub head and disconnect the scrub brush motor from the main harness. Note the orientation of wire to motor.

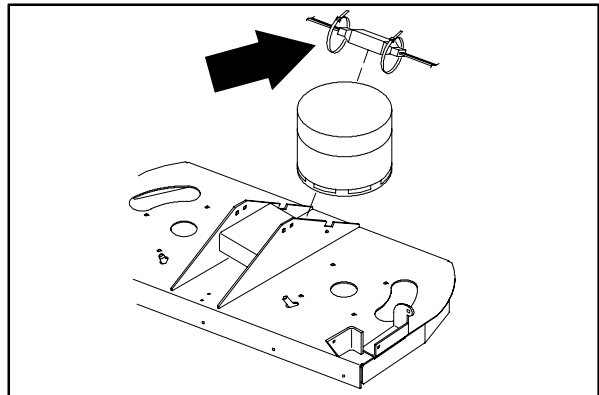

8. Lift the brush motor off the deck of the scrub head and remove it from the machine. Note the orientation of the brush motor power cable. The new motor must be orientated the same direction.

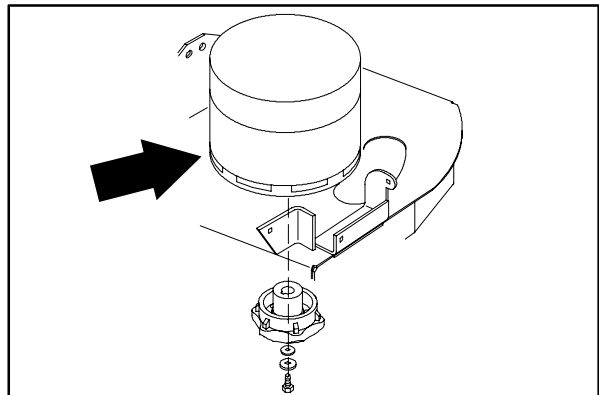

M

# T15 Maintenance & Repair

9. Position the new motor on the scrub head.

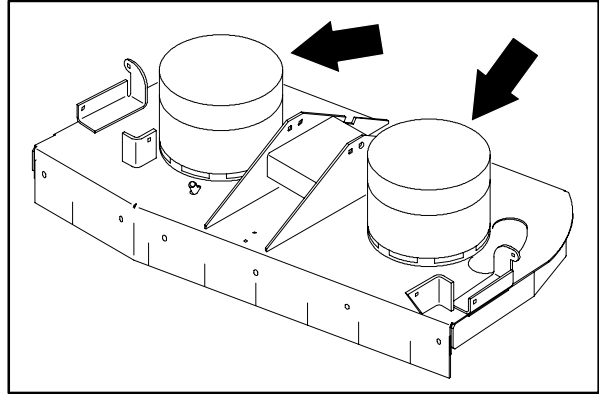

10. Reconnect the motor wires to the main electrical harness. See schematic in this section.

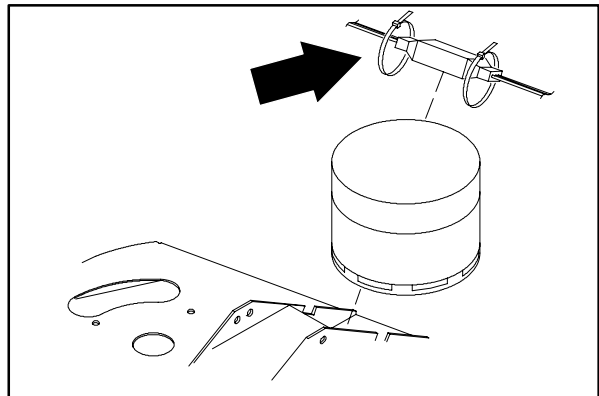

11. Start the machine and raise the scrub head. Shut off the key.



12. Rotate the brush motor until it is orientated properly and the mount holes line up with the holes in the deck of the scrub head. Install the four screws and tighten to 11 - 14 Nm (7 - 10 ft lb).

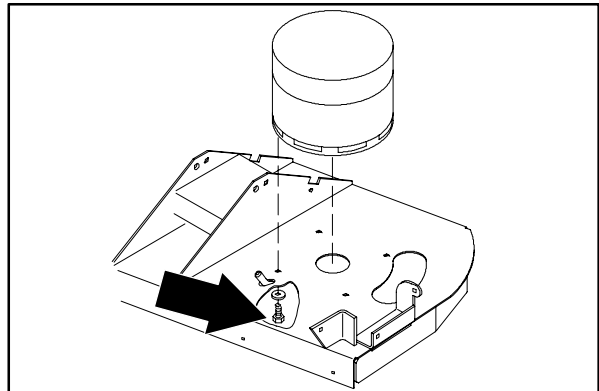

# T15 Maintenance & Repair

13. Install the square key and drive plug on the brush motor shaft. Install the screw and washer in the center of the drive plug. Tighten to 18 - 24 Nm (15 - 20 ft lb).

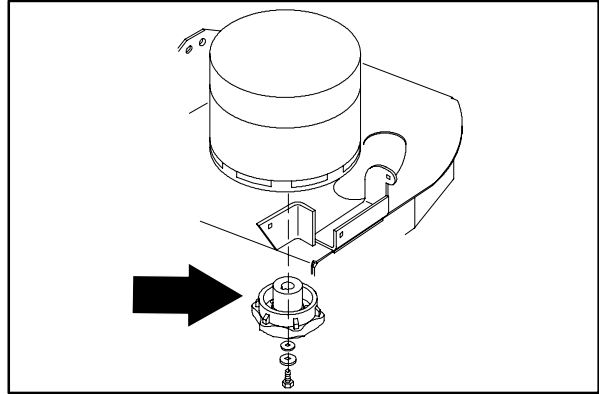

14. Reinstall the scrub brush. See TO REPLACE DISC SCRUB BRUSHES instructions in the SCRUBBING section.

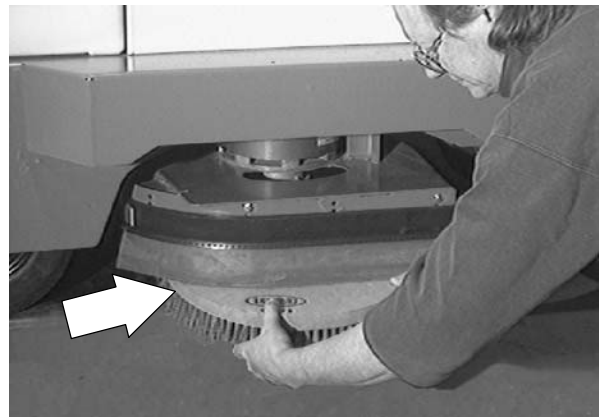

15. Reinstall the side squeegees. See TO REPLACE SIDE SQUEEGEE BLADES instructions in the SCRUBBING section.

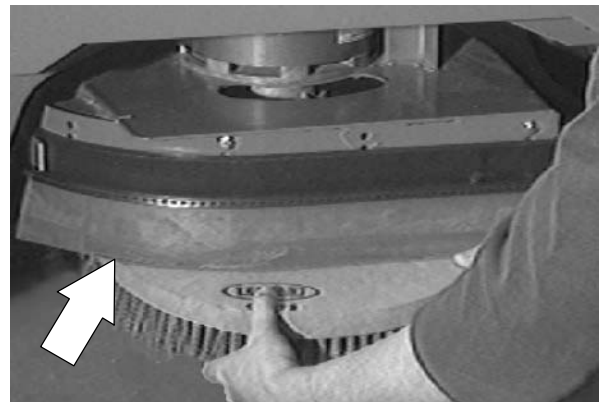

16. Start the machine and operate the scrubbing function. Check for proper operation and rotation of the new motor.

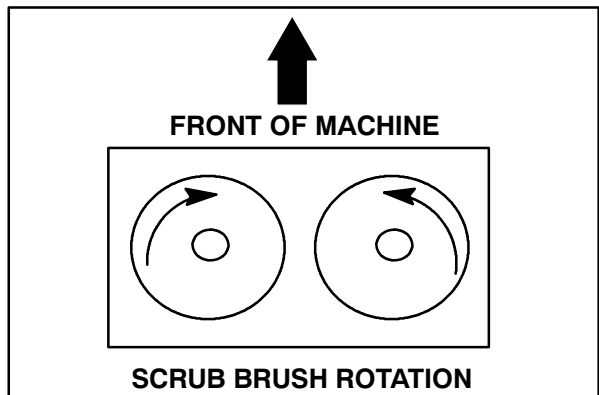

# T15 Maintenance & Repair

## TO REMOVE CYLINDRICAL SCRUB HEAD

1. Start the machine and lower the scrub head to the floor. Shut off the key.

**FOR SAFETY: Before Leaving Or Servicing Machine; Stop On Level Surface, turn key switch OFF.**



2. Disconnect the water line leading from the shut off valve to the scrub head.

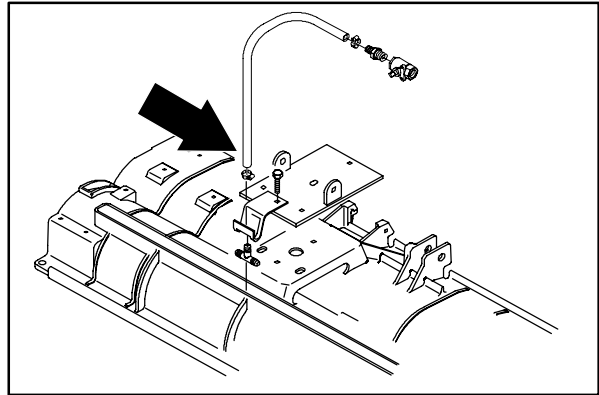

3. Disconnect the two scrub brush motors from the main electrical harness. Mark the connectors for proper re-assembly.

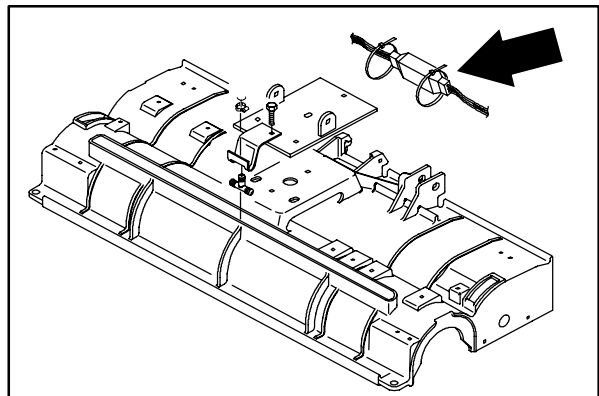

# T15 Maintenance & Repair

4. Remove the cotter pin and clevis pin from the scrub head lift mechanism where it attaches to the scrub head.

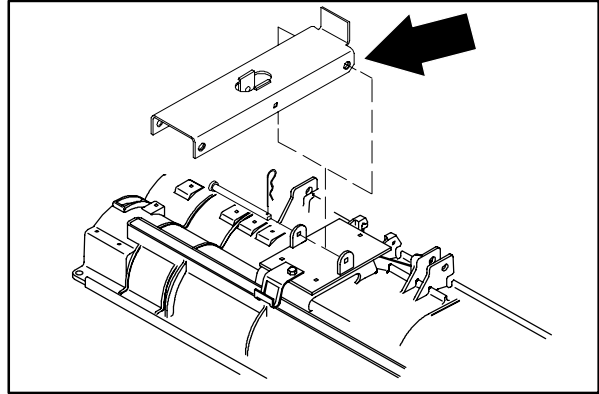

5. Remove the nyloc nut holding the ball joint to the mount bracket on the scrub head. Do this on both sides of the machine.

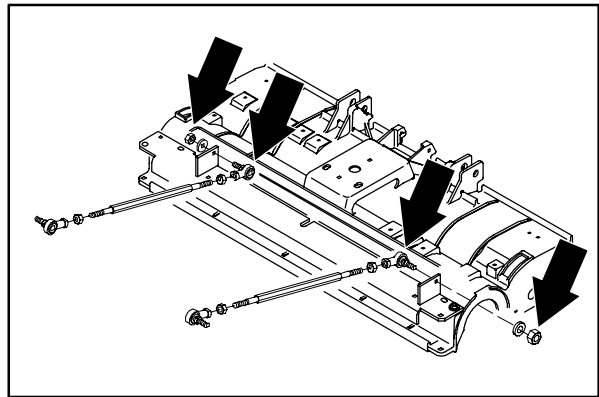

6. Turn on the machine and raise the scrub head lift actuator. Turn off the machine.

*NOTE: This will allow more clearance for the scrub head to slide out.*



7. The scrub head can now be pulled out from under the machine frame.





# T15 Maintenance & Repair

## TO INSTALL CYLINDRICAL SCRUB HEAD

**FOR SAFETY: Before Leaving Or Servicing Machine; Stop On Level Surface, turn key switch OFF.**

1. Slide the scrub head under the machine frame with the scrub head link mount holes facing the front.
2. Install the ball joint on the end of the scrub head link into the mount hole on the scrub head. The ball joint should be positioned so it is facing the inside of the machine frame. Do this on both sides of the machine.

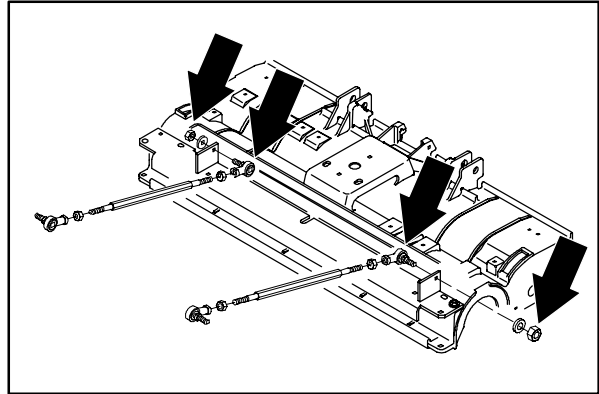

3. Position the scrub head as close as possible to the center. Turn on the machine and lower the scrub head lift actuator.

*NOTE: Do this in small increments until the mount hole in the scrub head lines up with the mount hole in the lift mechanism.*

4. Install the clevis pin and cotter pin.

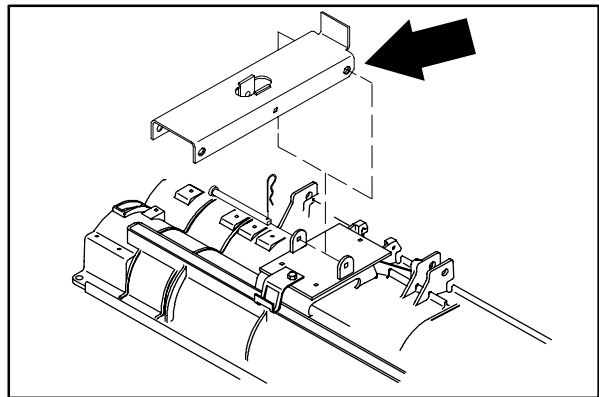

5. Reconnect the brush drive motors to the main electrical harness.

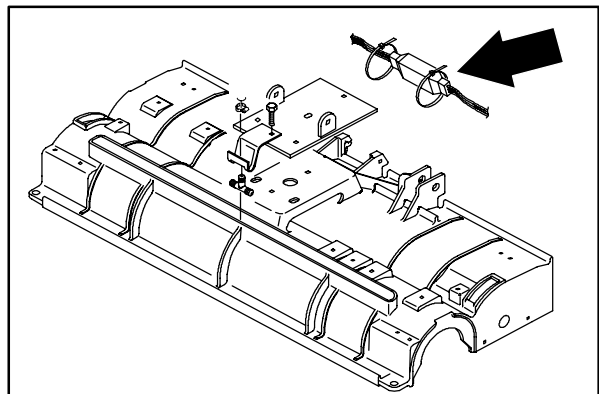

# T15 Maintenance & Repair

6. Reconnect the water line to the scrub head

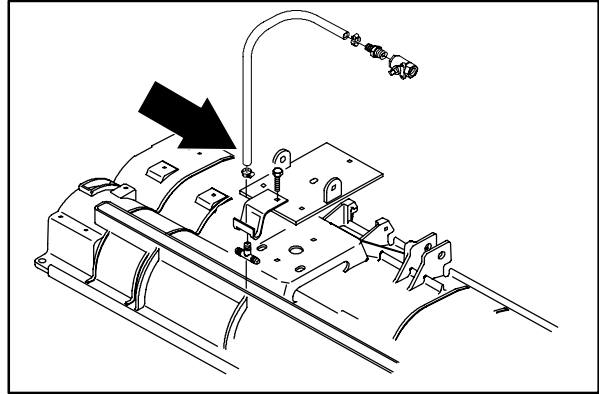

7. Start the machine and raise the scrub head. Operate the machine and check the scrub head for proper operation. Check the scrub brushes for pattern and proper rotation. See TO CHECK AND ADJUST CYLINDRICAL BRUSH PATTERN instructions.

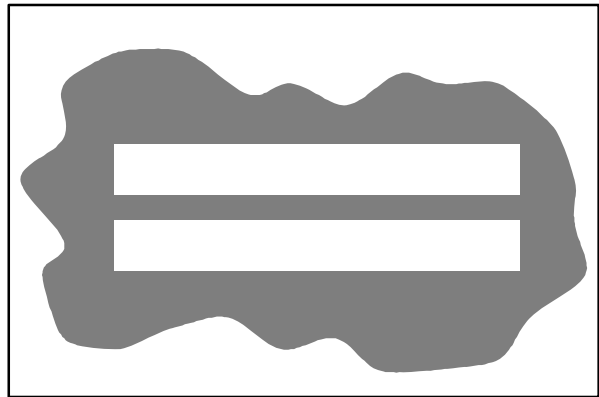

10355



# T15 Maintenance & Repair

## TO REPLACE CYLINDRICAL SCRUB HEAD BRUSH MOTOR

**FOR SAFETY: Before Leaving Or Servicing Machine; Stop On Level Surface, turn key switch OFF.**

1. Remove the side squeegees. See TO REPLACE SIDE SQUEEGEE BLADES instructions in the SCRUBBING section.

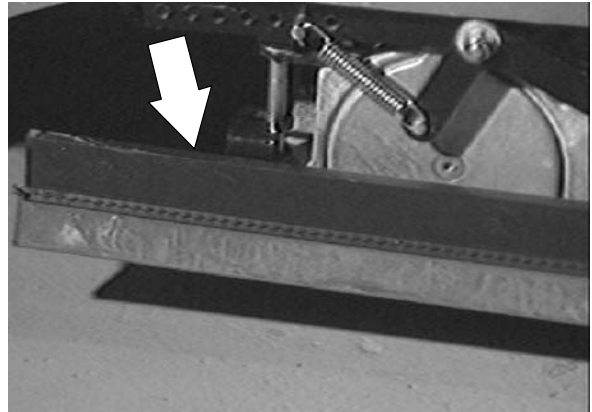

2. Remove the scrub brushes. See TO REPLACE DISC SCRUB BRUSHES instructions in the SCRUBBING section.

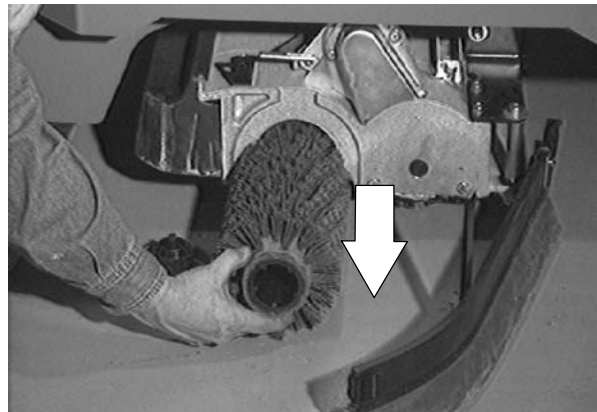

3. Start the machine and lower the scrub head. Shut off the key.



# T15 Maintenance & Repair

4. Go in on top of the scrub head and disconnect the scrub brush motor from the main harness. Note the orientation of wire to motor.

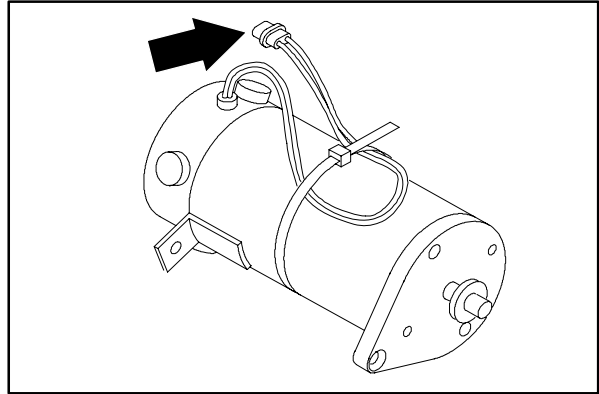

5. Loosen the front and rear pivot mount bolts on the brush motor.

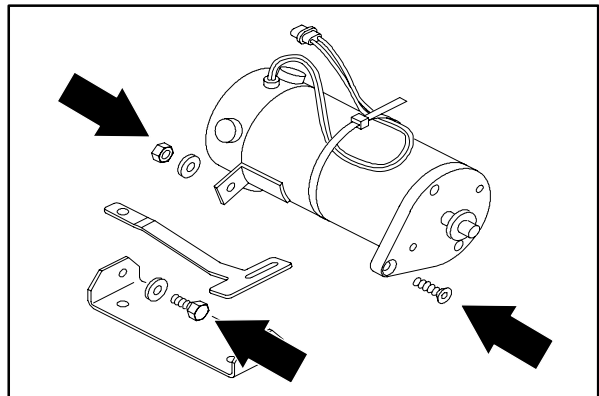

6. Remove the two screws holding the brush motor belt cover to the brush motor. Remove the belt cover from the scrub head.

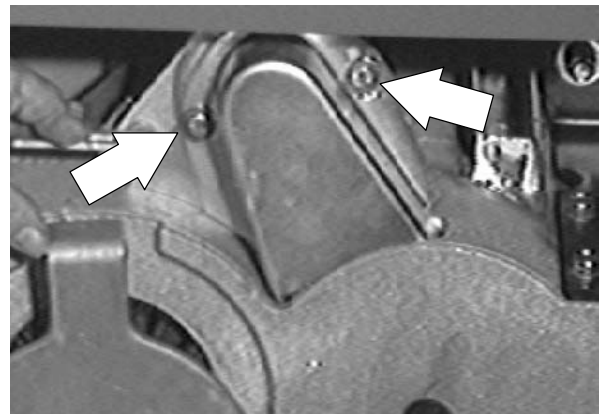

7. Loosen the jam nut on the belt tension bolt under the brush motor. Turn the tension bolt down far enough to slip the the belt off the cogged pulley.

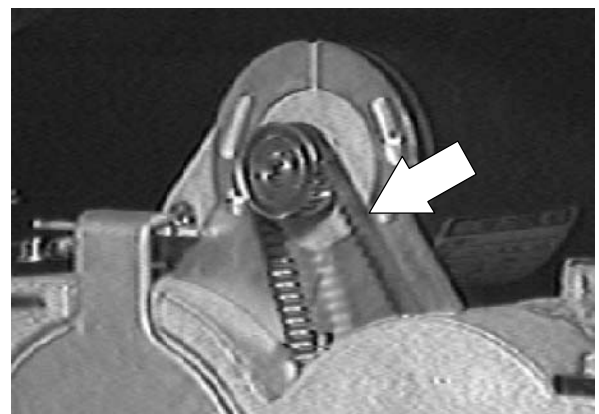

# T15 Maintenance & Repair

8. Remove the two screws holding the brush motor to the pivot bracket. Remove the brush motor from the machine.

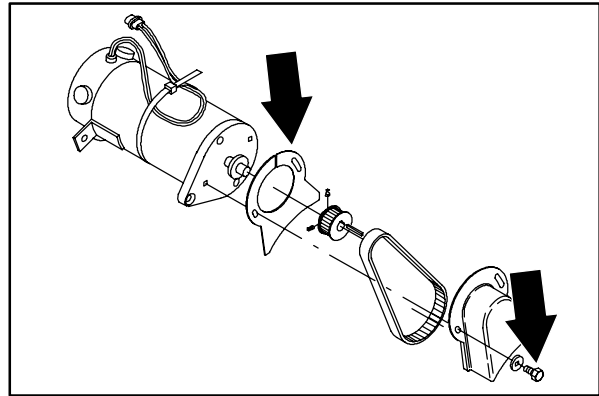

9. Loosen the set screws holding the cogged pulley to the brush motor shaft. Slide the pulley off the shaft.

*NOTE: Do not loose the square key.*

10. Install the cogged pulley and square key onto the shaft of the new brush motor.

*NOTE: Leave the set screws loose for now.*

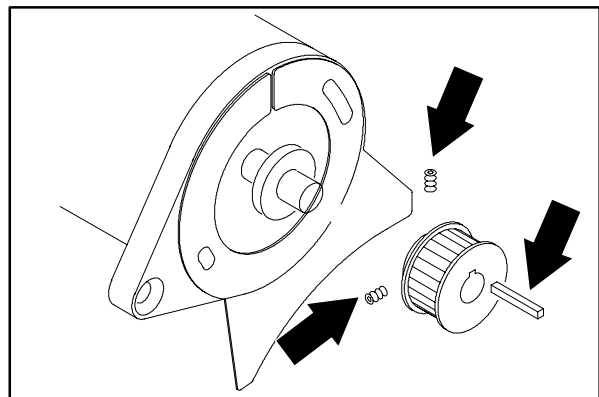

11. Position the new brush motor on the scrub head. Align the mounting holes on the motor with the holes in the pivot mount bracket. Install the two screws. Snug the hardware for now.

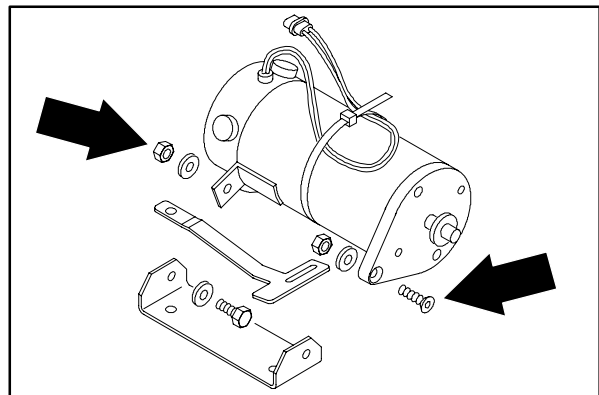

12. Slip the brush belt over the cogged pulley.

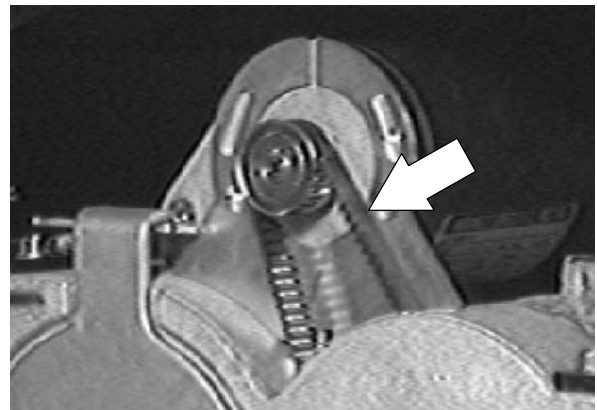

M

# T15 Maintenance & Repair

13. Align the top pulley with the bottom drive plug. Make sure the belt is in the center of the top pulley. Tighten the set screws tight.

*NOTE: Use loctite 242 blue on the threads.*

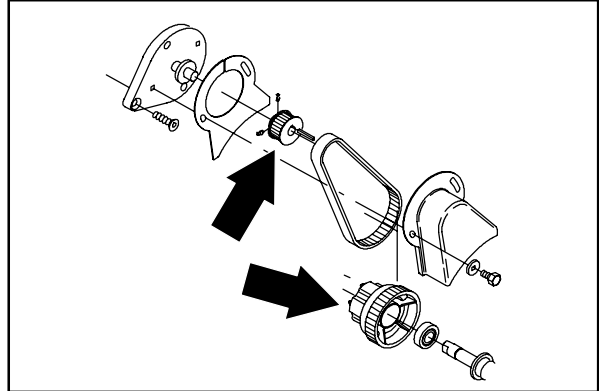

14. Use the hex screw under the brush motor to tension the belt. Apply 2.5-2.7 lbs. of force at the middle of the span that is opposite belt travel.

*NOTE: There should be 0.10 inch of deflection.*

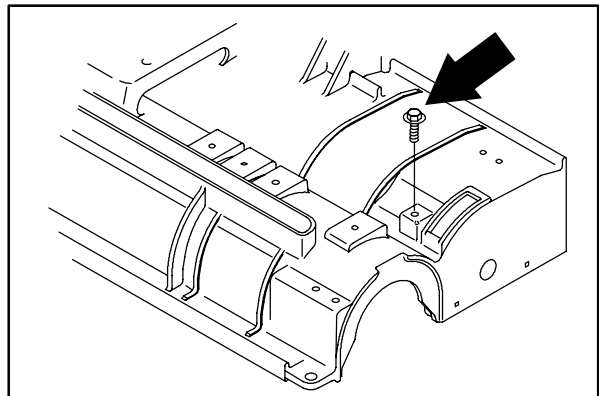

15. Tighten the two motor pivot screws to 18 - 24 Nm (15 - 20 ft lb). Re-check the belt tension.

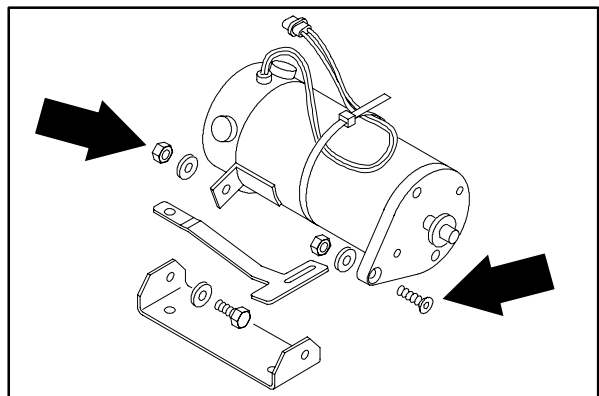

16. Reconnect the brush motor into the main harness.

*NOTE: See schematic in this section.*

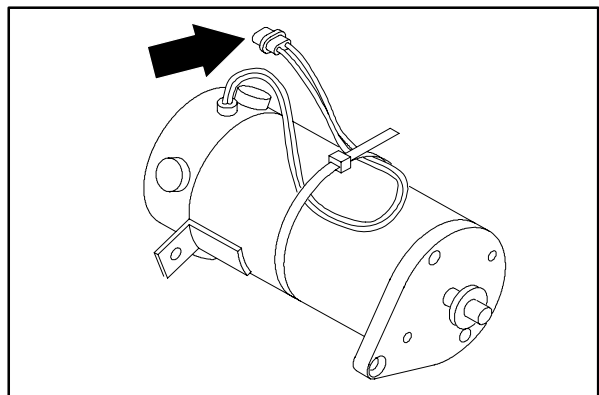

## T15 Maintenance & Repair

17. Reinstall the belt cover. Tighten the screws to 11 - 14 Nm (7 - 10 ft lb). Apply a small amount of RTV sealant on the flange of the belt cover to keep dust out of the cogs of the belt.

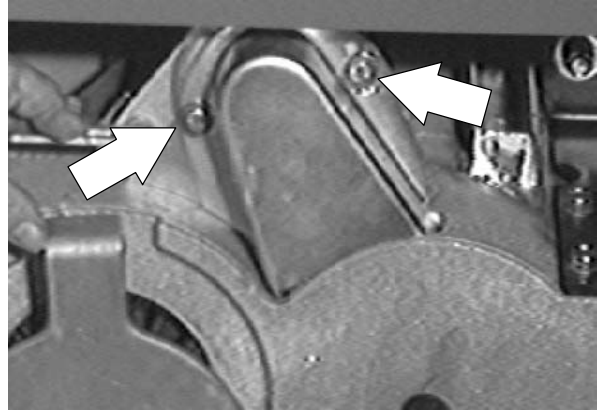

18. Reinstall the scrub brushes. See TO REPLACE CYLINDRICAL SCRUB BRUSHES instructions in the SCRUBBING section.

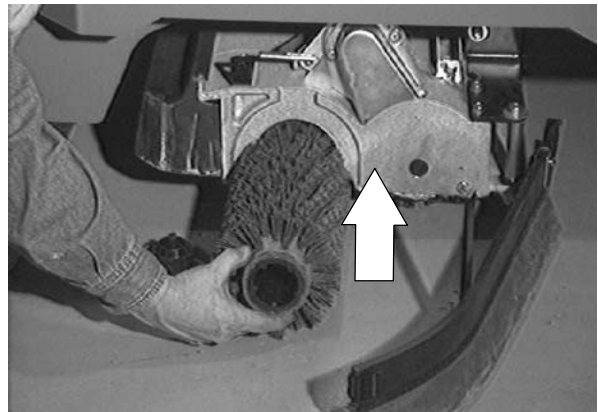

19. Operate the machine and check the scrub brush motor for proper operation.



# T15 Maintenance & Repair

---

## CYLINDRICAL BRUSH DRIVE BELT

---

The two brush drive belts are located on the cylindrical brush scrub head. The belts drive the cylindrical brushes. Proper belt tension is a 3 mm (0.1 in) deflection from a force of 1.1 to 1.2 kg (2.5 to 2.7 lb) at the belt midpoint.

Check and adjust the belt tension every 100 hours of operation.

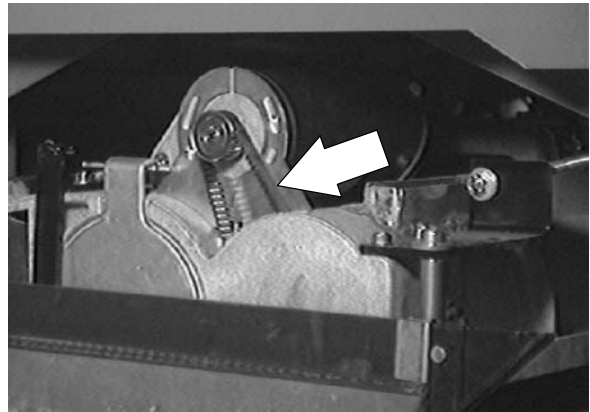

## TO REPLACE BRUSH DRIVE BELT

1. Start the machine and lower the scrub head near the floor. Shut off the key.

**FOR SAFETY: Before Leaving Or Servicing Machine; Stop On Level Surface, turn key switch OFF.**



2. Remove the scrub brushes. See TO REPLACE CYLINDRICAL SCRUB BRUSHES instructions.

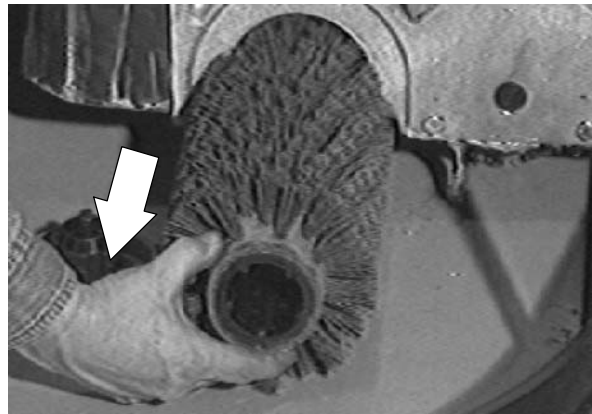



# T15 Maintenance & Repair

3. Remove the two screws holding the belt cover to the scrub brush motor. Remove the belt cover from the scrub head.

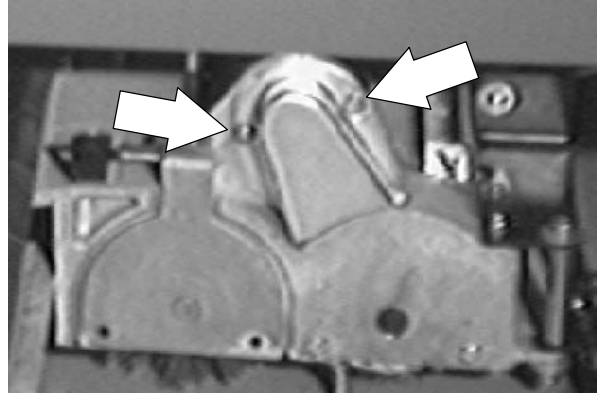

4. Loosen the two pivot bolts on the bottom of the brush motor.
5. Loosen the belt tension bolt under the brush motor. Turn the bolt down far enough to allow the belt to be slipped off the motor pulley. Push the drive belt down toward the lower brush drive plug.

*NOTE: Make sure the scrub head is slightly off the floor before attempting to remove the drive plug rubber seal.*

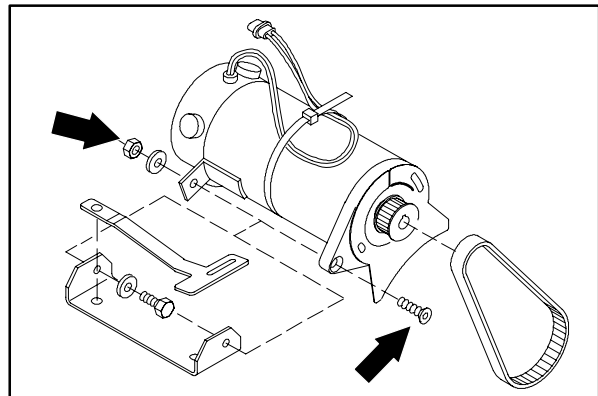

6. Cut the RTV sealant around the rubber seal. Use a needle nose pliers to remove it from the brush drive plug. Note the orientation of the seal. Remove the drive plug.

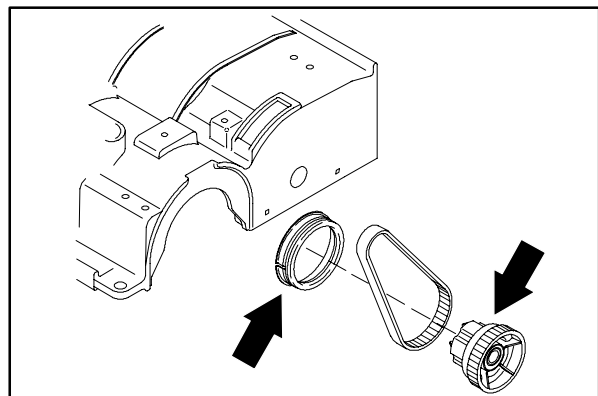

7. Remove the brush drive belt from the machine.

*NOTE: It is a tight fit for the belt in the area of the lower belt cover and bottom drive plug. Carefully work the belt past the lower cover--DO NOT remove the lower cover.*

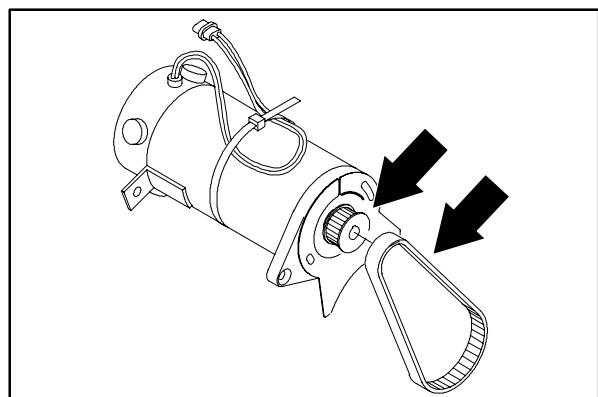

# T15 Maintenance & Repair

8. Slip the new drive belt into position. Push the rest of the drive belt up toward the motor belt pulley. Slip the drive belt over the motor belt pulley.

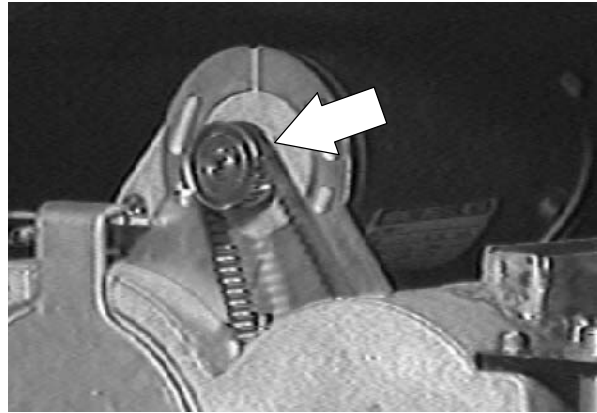

9. Reinstall the brush drive plug. Install the drive belt over the drive plug.
10. Reinstall the rubber seal on the drive plug. Note the orientation of the seal. Use RTV-Blue sealant all around the seal when installing.

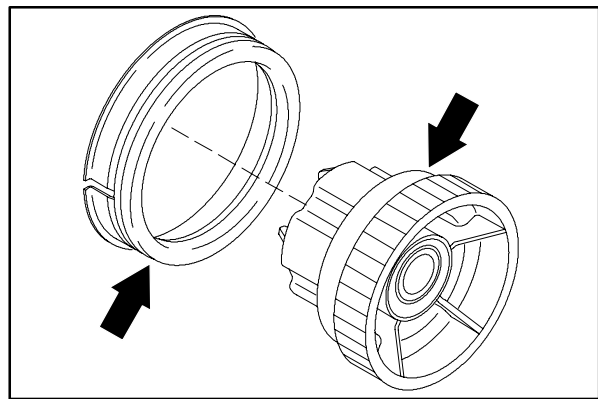

11. Use the tension bolt under the drive motor to tighten the drive belt. Apply 2.5 - 2.7 lbs of force to the drive belt in the middle of the span. The belt should deflect 0.10 inch.

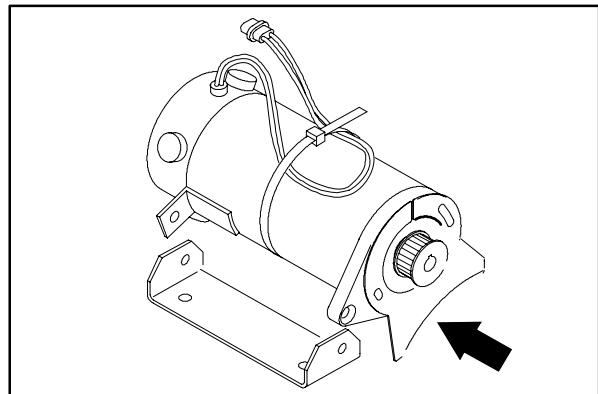

12. Tighten the drive motor pivot bolts to 18 - 24 Nm (15 - 20 ft lb). Re-check the belt tension.

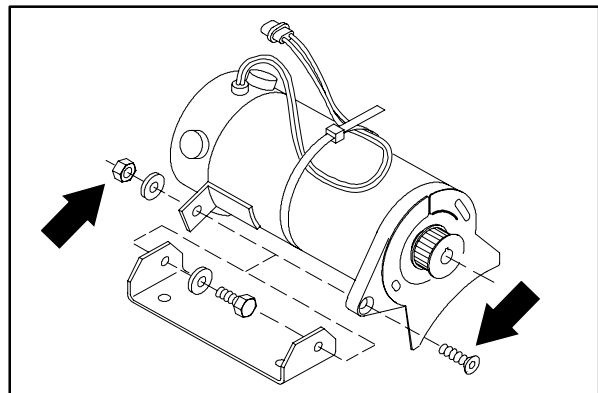

## T15 Maintenance & Repair

13. Reinstall the belt cover. Tighten the screws to 11 - 14 Nm (7 - 10 ft lb).

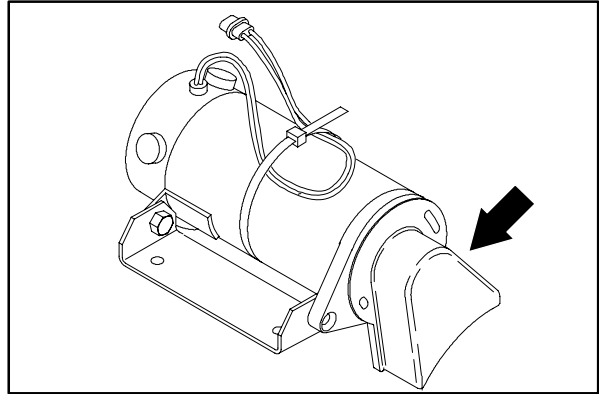

14. Reinstall the scrub brushes. See TO REPLACE CYLINDRICAL SCRUB BRUSHES instructions.

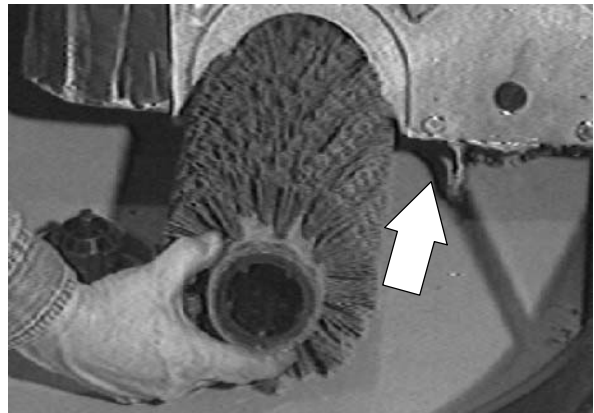

15. Operate the machine and check the scrub brushes for proper operation.



# T15 Maintenance & Repair

---

## DISC SCRUB HEAD SKIRTS

---

### SCRUB HEAD FLOOR SKIRTS

The scrub head floor skirts control water spray from the brushes. The skirts are located in front and rear of the scrub head. Check these skirts for wear and damage after every 50 hours of operation.

The skirts should clear the floor by 0 to 0.25 in. (0 to 6mm) when the scrub head is down. Check the floor skirt adjustment after every 50 hours of operation.

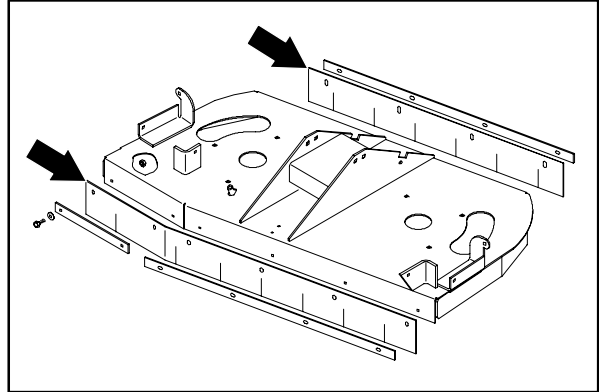

### TO ADJUST DISC SCRUB HEAD SKIRTS

1. Start the machine and lower the scrub head to the floor. Shut off the key.

**FOR SAFETY: Before Leaving Or Servicing Machine; Stop On Level Surface, turn key switch OFF.**



2. Loosen the screws holding the retainer and skirt to the scrub head frame.
3. Position the up or down as needed to achieve 1/8 to 1/4 inch clearance from the bottom of the skirt to the floor.
4. Re-tighten the retainer screws. Operate the machine and check the scrub head skirts for proper water spray control.

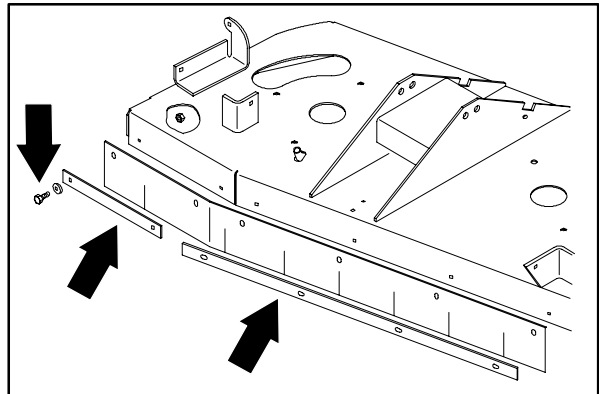

# T15 Maintenance & Repair

## TO REPLACE DISC SCRUB HEAD SKIRTS

1. Start the machine and lower the scrub head to the floor. Shut off the key.

**FOR SAFETY: Before Leaving Or Servicing Machine; Stop On Level Surface, turn key switch OFF.**



2. Remove the screws holding the retainer and skirt to the scrub head frame. Remove and discard the skirt.
3. Position the new skirt and existing retainer on the scrub head. Adjust the skirt and tighten the retainer screws. See TO ADJUST DISC SCRUB HEAD SKIRTS instructions.
4. Operate the machine and check the scrub head skirts for proper water spray control.

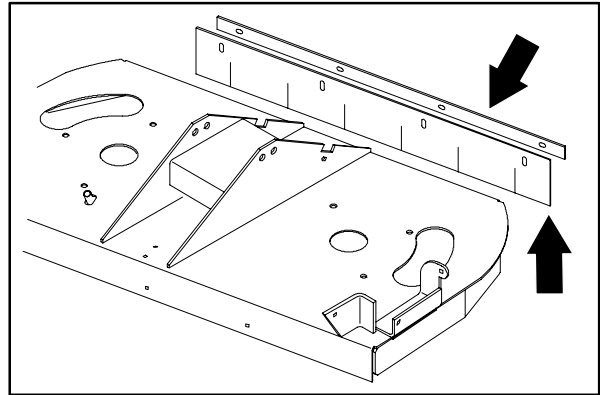

# T15 Maintenance & Repair

---

## CYLINDRICAL BRUSH HEAD DEBRIS TRAY

---

The cylindrical style scrub head is equipped with a rear mounted debris tray. Small debris is picked up by the two cylindrical scrub brushes and deposited in the debris tray located behind the rear scrub brush. The debris tray can be easily removed and emptied.



### TO REMOVE DEBRIS TRAY

1. Start the machine and touch the scrub button. Shut off the key when the scrub head is near the floor.

*NOTE: Do not touch the directional pedal.*

**FOR SAFETY: Before Leaving Or Servicing Machine; Stop On Level Surface, turn key switch OFF.**



2. Go to the right side of the machine. Locate the scrub head side squeegee. Pull the hair pin out of the squeegee lock pin.
3. Pivot the side squeegee out, away from the scrub head.

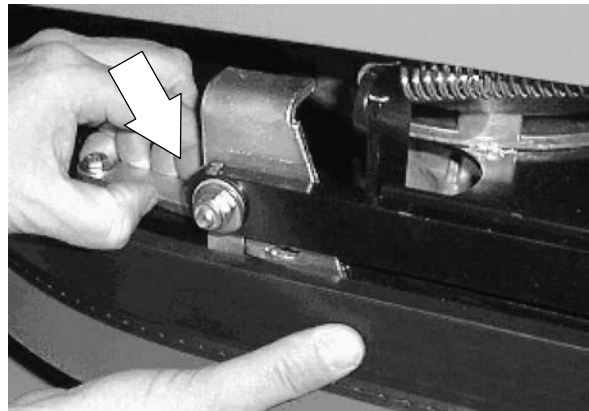

## T15 Maintenance & Repair

4. Grasp the plastic debris tray and pivot the bottom up, away from the back of the scrub head. Pivot the debris tray far enough to allow the rubber skirt to clear the scrub head.

5. Pull the debris tray straight out to the right until it is free of the scrub head lip. Empty the debris tray.

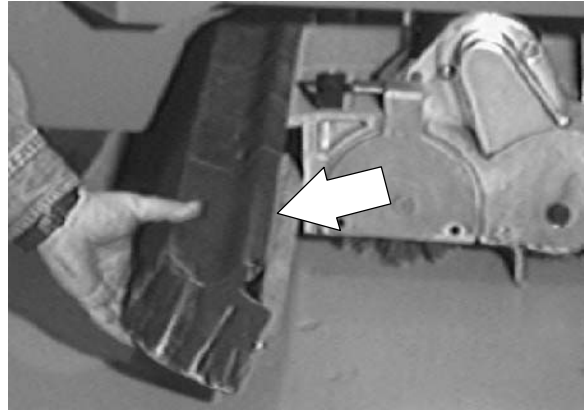

# T15 Maintenance & Repair

## TO INSTALL DEBRIS TRAY

1. Lower the scrub head to the floor.

**FOR SAFETY: Before Leaving Or Servicing Machine; Stop On Level Surface, turn key switch OFF.**



2. Position the debris tray, opening facing forward, on the lip on the back of the scrub head. Push the debris tray in until it stops.

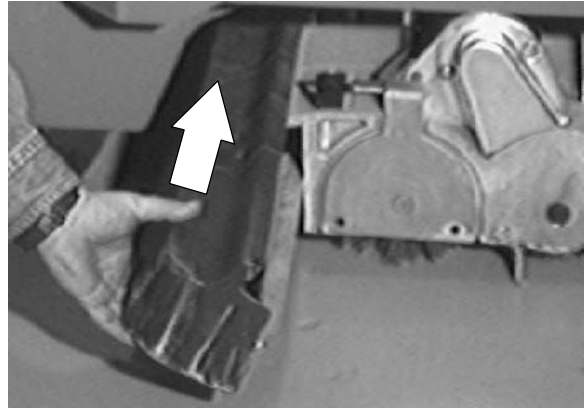

3. Swing the right hand side squeegee back to the side of the scrub head. Make sure the lock pin is positioned in the mount hole. Reinstall the hair pin.

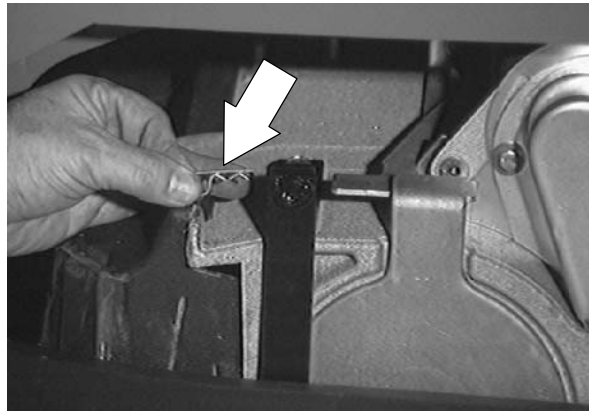

4. Start the machine and raise the scrub head.

M



# T15 Maintenance & Repair

## TO REPLACE DEBRIS TRAY SKIRT

1. Remove the debris tray. See TO REMOVE DEBRIS TRAY instructions.

**FOR SAFETY: Before Leaving Or Servicing Machine; Stop On Level Surface, turn key switch OFF.**

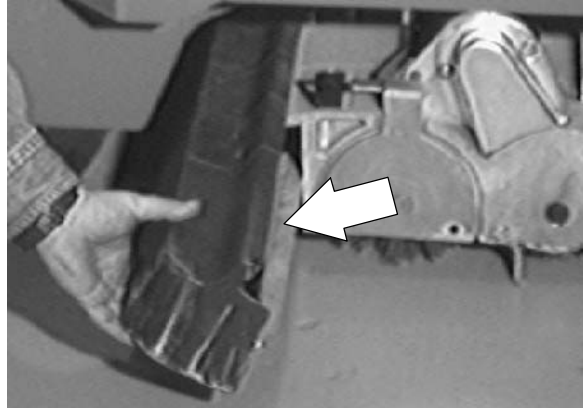

2. Remove the six screws, washers, and nuts holding the debris tray skirt and retainer to the top lip of the tray. Remove the retainer and skirt. Discard the skirt.
3. Position the new debris tray skirt and existing retainer on the top lip of the tray.
4. Reinstall the hardware and hand tighten lightly.

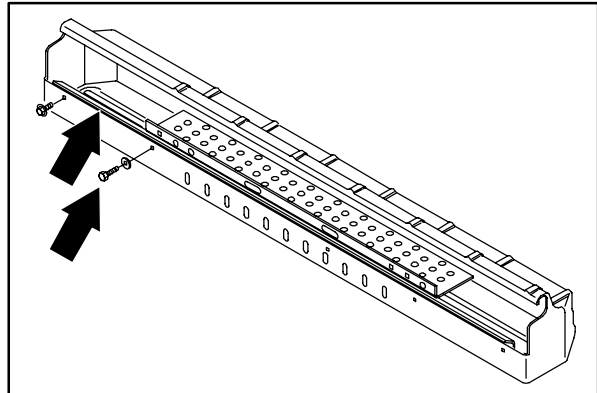

5. Reinstall the debris tray in the machine. See TO INSTALL DEBRIS TRAY instructions.

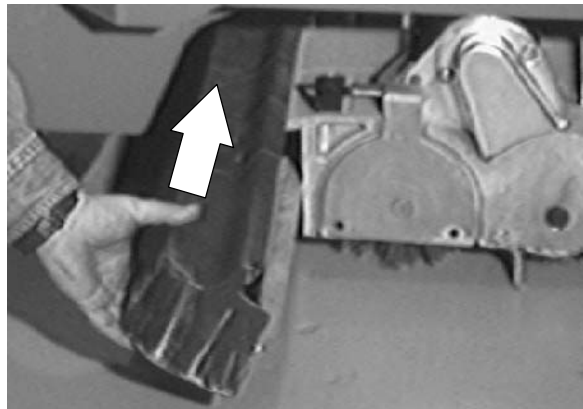

# T15 Maintenance & Repair

---

## SCRUB BRUSHES

---

The machine can be equipped with either *disk* or *cylindrical* scrub brushes. Check scrub brushes daily for wire or string tangled around the brush or brush drive hub. Also check for brush damage and wear.

### DISC SCRUB BRUSHES

The disk brushes should be replaced if a large number of bristles are missing or if bristle length is less than 10 mm (0.38 in).

*NOTE: Replace worn brushes in pairs. Scrubbing with brushes of unequal bristle length will result in diminished scrubbing performance.*

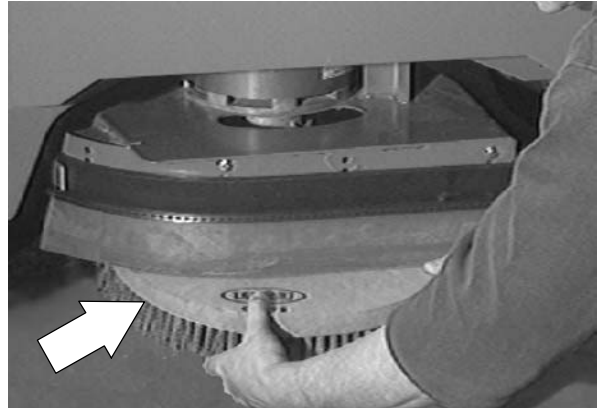

### TO REPLACE DISC SCRUB BRUSHES

1. Raise the scrub head.
2. Turn the machine power off.

**FOR SAFETY: Before Leaving Or Servicing Machine; Stop On Level Surface, turn key switch OFF.**



3. Turn the brush until you can see the brush spring clip.
4. Press the brush spring clip together with your thumb and index finger. The brush will drop off of the brush drive hub. Pull the brush out from under the scrub head.

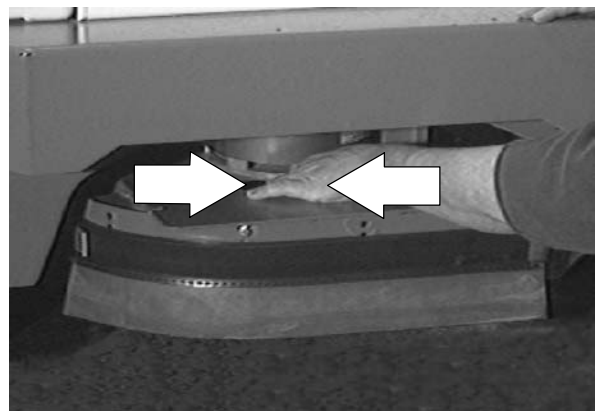

# T15 Maintenance & Repair

5. Place the new scrub brush on the floor in front of the scrub head. Push the brush under the scrub head.
6. Line up the brush drive socket with the drive plug.

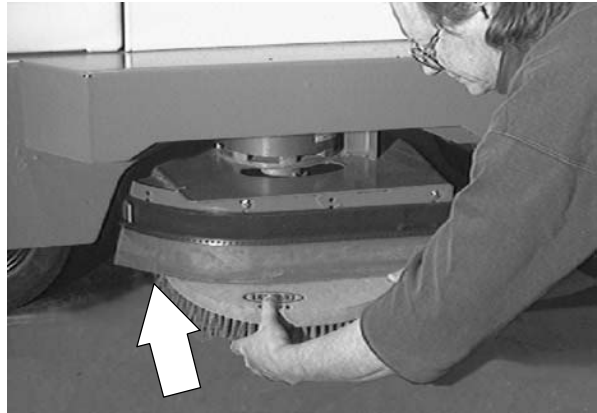

7. While pressing the brush spring clip together with your thumb and index finger, lift the scrub brush onto the drive plug.
8. Check to make sure the brush is securely mounted on the brush drive hub.
9. Repeat for the other brush.

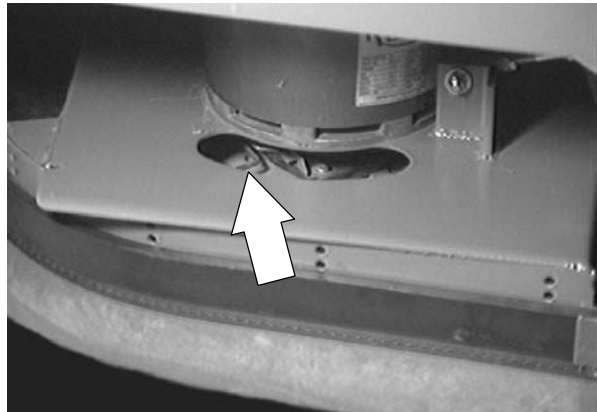

# T15 Maintenance & Repair

## CYLINDRICAL SCRUB BRUSHES

Check the brush taper and rotate the brushes from front-to-rear every 50 hours of machine operation for maximum brush life and best scrubbing performance.

The cylindrical brushes should be replaced if large amounts of bristles are missing, or if the remaining bristle length is less than 10 mm (0.38 in).

*NOTE: Replace worn brushes in pairs. Scrubbing with brushes of unequal bristle length will result in diminished scrubbing performance.*

*NOTE: Fill the solution tank before checking or adjusting the brush pattern.*

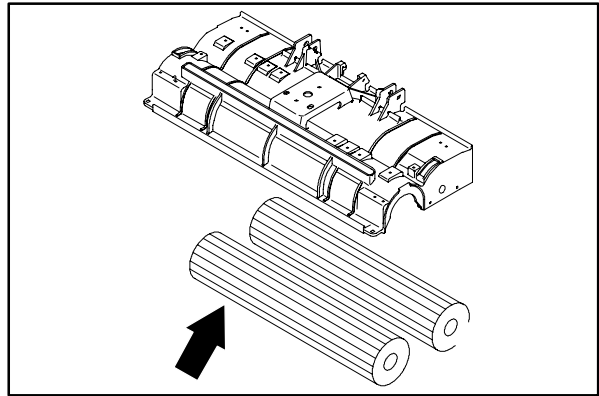

## TO REPLACE CYLINDRICAL SCRUB BRUSHES

1. Press the scrubbing switch. When the scrub head is approximately 25 mm (1 in) from the floor, turn the machine power off.

**FOR SAFETY: Before Leaving Or Servicing Machine; Stop On Level Surface, turn key switch OFF.**

2. Remove the cotter pin that holds the side squeegee in place. Swing the squeegee away from the scrub head.

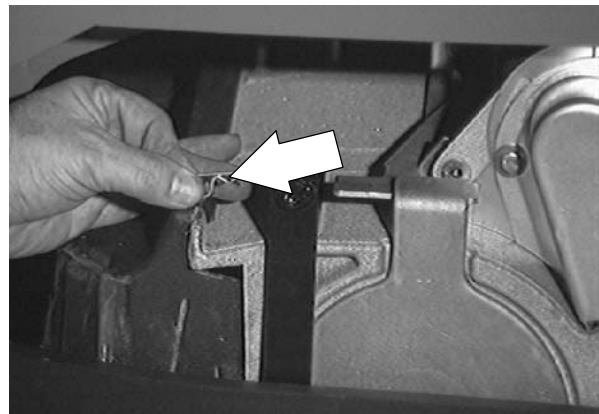

3. Push downward on the mounting spring and idler door until the top of the door releases from the scrub head. Pull the bottom of the door outward, then pull the idler door and idler plug off of the brush.

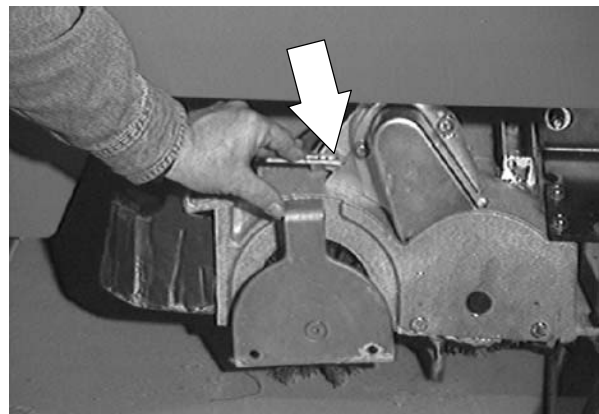

# T15 Maintenance & Repair

4. Pull the old brush out of the scrub head.

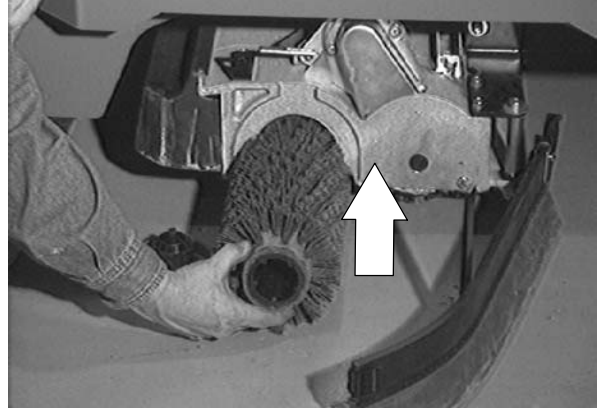

5. Position the brush with the *double row end towards you*. Guide the new brush onto the drive hub.

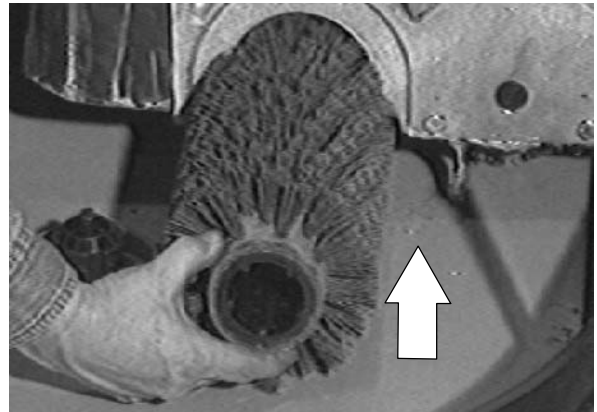

6. Insert the Idler plug (on the inside of the idler door), into the brush.

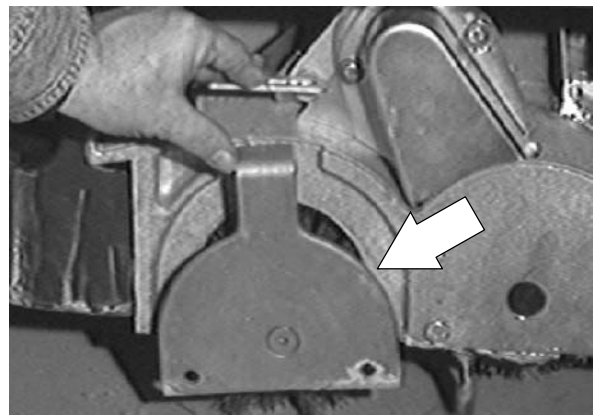

7. Push down on the door to catch the door in the scrub head, then pull up on the door to latch it into the spring.

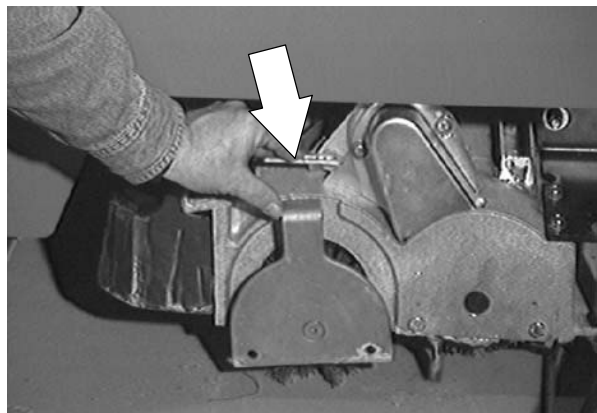

8. Repeat for the other brush on the other side of the scrub head.

**NOTE:** Each side of the scrub head is stamped with a letter. The idler door of that side of the scrub head is stamped with the same letter. Make sure the letter on the door matches the letter on the scrub head when replacing the doors.



# T15 Maintenance & Repair

## TO CHECK AND ADJUST CYLINDRICAL BRUSH PATTERN

1. Apply chalk (or another material that will not easily blow away), to a smooth, level section of the floor.
2. Lower the scrub head in the chalked area. Allow the machine to scrub in the same place for 15 to 20 seconds.

*NOTE: If chalk or other material is not available, allow the brushes to spin on the floor for two minutes. A polish mark will remain on the floor.*



3. Raise the scrub head and move the machine away from the chalked area. Turn the machine power off.

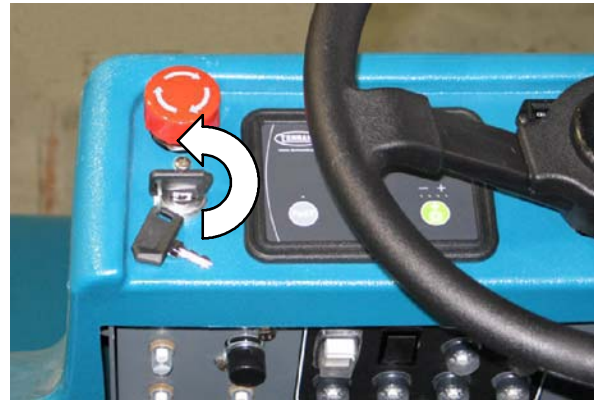

4. Observe the shape of the brush patterns. If the brush patterns have parallel sides, the brushes do not need adjustment.

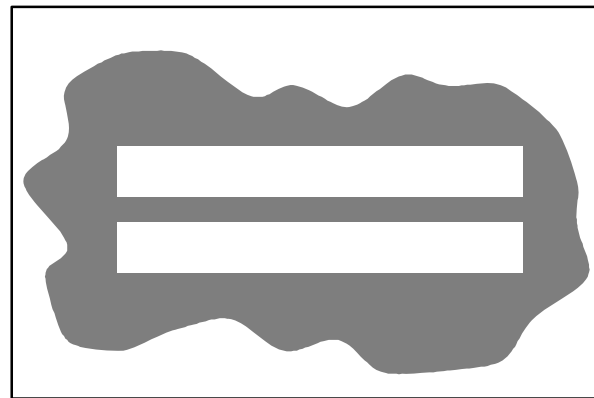

10355

# T15 Maintenance & Repair

If one, or both of the brush patterns are tapered, the brushes need adjustment to straighten the brush pattern.

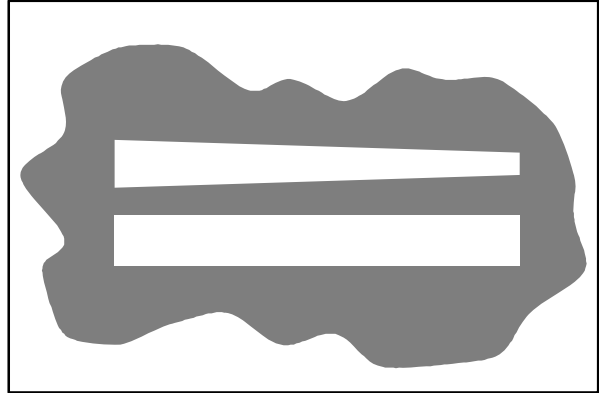

1. To adjust brush taper, push downward on the mounting spring and idler door until the top of the door releases from the scrub head. Pull the bottom of the door outward, then pull the idler door and idler plug off of the brush.

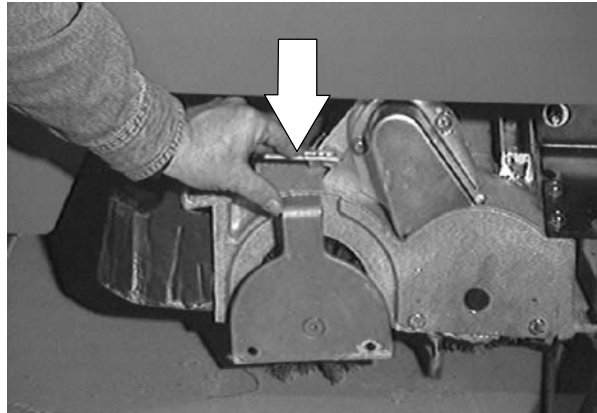

2. While holding the flat end of the idler shaft with a wrench, loosen the mounting screw on the outside of the idler door.



# T15 Maintenance & Repair

3. Turn the idler shaft to raise or lower the end of the brush as needed to straighten the brush pattern. Tighten the mounting screw.
4. Check the brush patterns again and readjust as necessary until both patterns are the same.

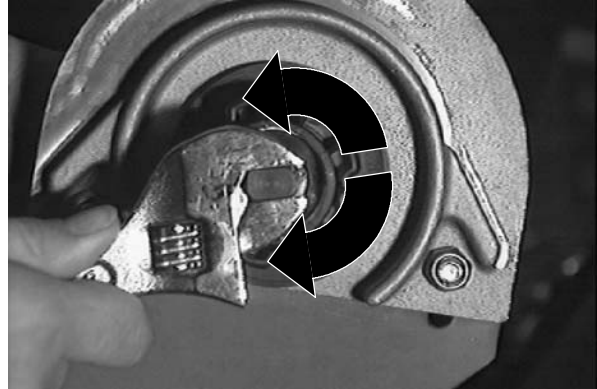

5. If one brush pattern is wider than the other, the scrub head needs to be leveled.

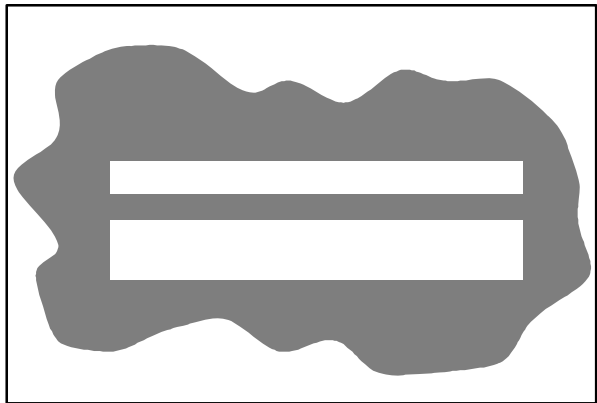

Level the scrub head by turning the scrub head links. Both scrub head links should be adjusted equally.

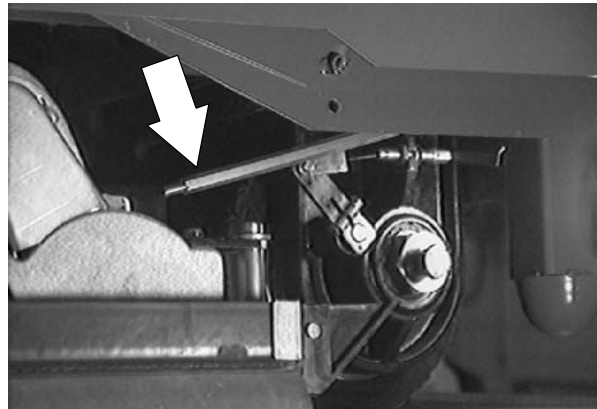

Check the brush patterns again and readjust as necessary until both patterns are the same.





# T15 Maintenance & Repair

---

## SCRUB HEAD LIFT ACTUATOR

---

The lift actuator is an electric device that, with a push of a switch, raises and lowers the scrub head.

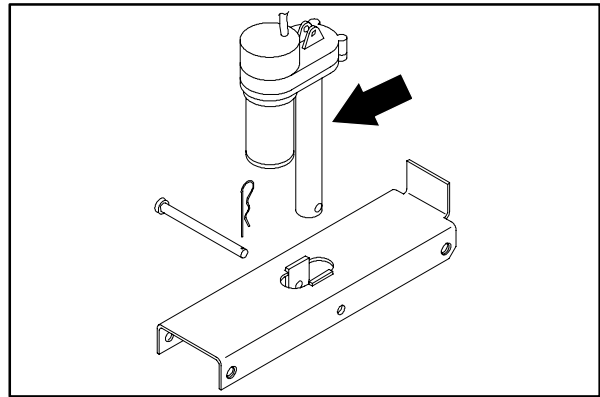

# T15 Maintenance & Repair

## TO REPLACE SCRUB HEAD LIFT ACTUATOR

1. Start the machine and lower the scrub head to the floor. Shut off the machine.

**FOR SAFETY: Before Leaving Or Servicing Machine; Stop On Level Surface, turn key switch OFF.**



2. Go in on top of the scrub head and remove the cotter pin and clevis pin from the bottom of the scrub head lift actuator tube.

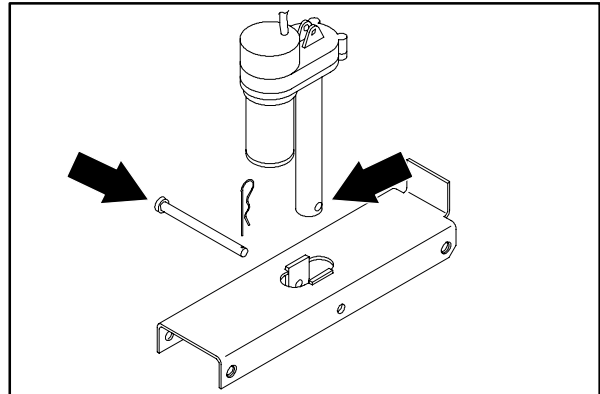

3. Go into the operators compartment and locate the two screws holding the lift actuator mount bracket to the front of the seat support. Remove the two screws.

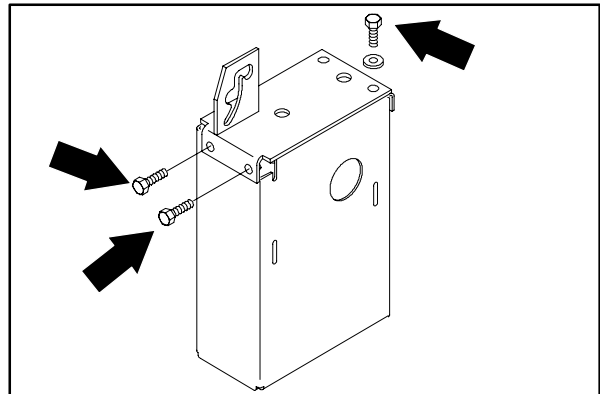

4. Raise the seat support and unplug the battery connector.

**FOR SAFETY: Disconnect Battery Connections Before Working On machine.**

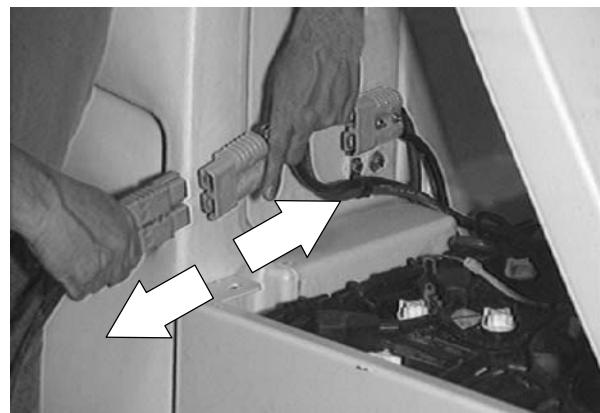

M

# T15 Maintenance & Repair

5. Tie the seat up. Remove the screw holding the seat prop rod to the bottom of the seat support. Remove the prop rod from the lock slot.

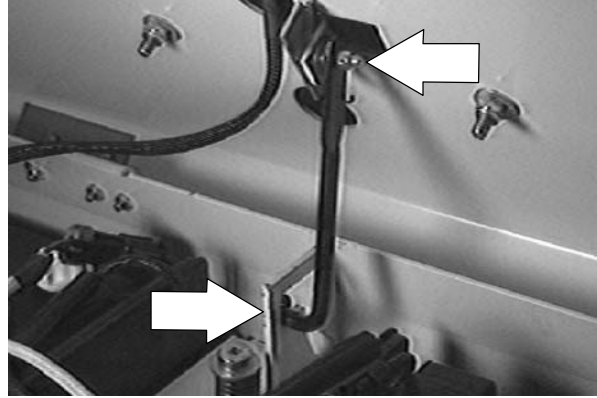

6. Locate the lift actuator spring mount bracket. Remove the two screws holding the mount bracket to the actuator mount assembly.

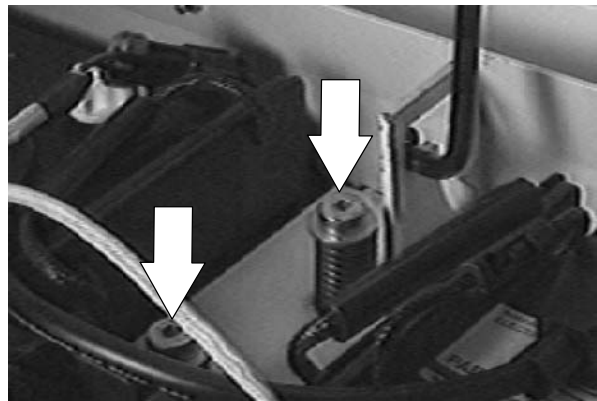

7. Lift the actuator and spring mount bracket out of the assembly and remove from the machine.

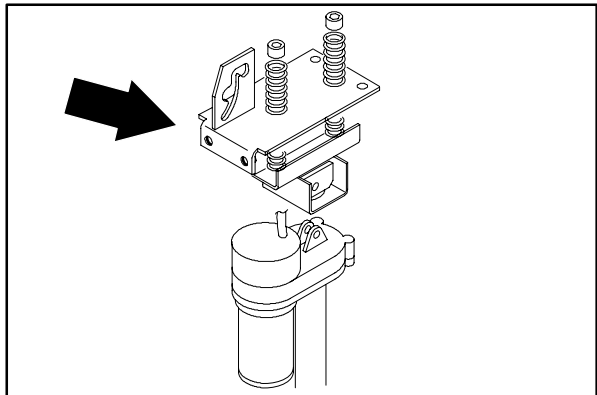

8. Remove the cotter pin and clevis pin holding the actuator to the bottom of the spring mount bracket. Remove the actuator. Note the orientation of the actuator on the bracket.

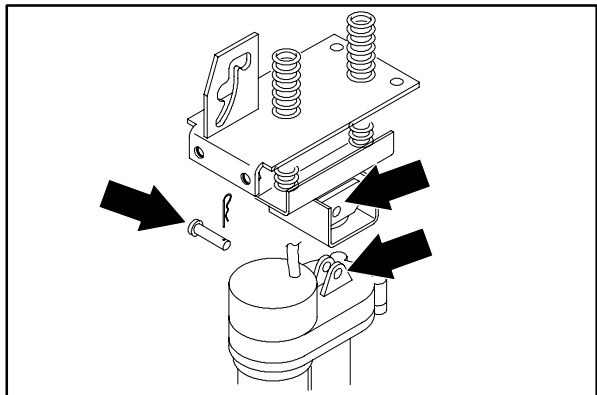

# T15 Maintenance & Repair

9. Position the new actuator on the spring mount bracket. Install the clevis and cotter pins.

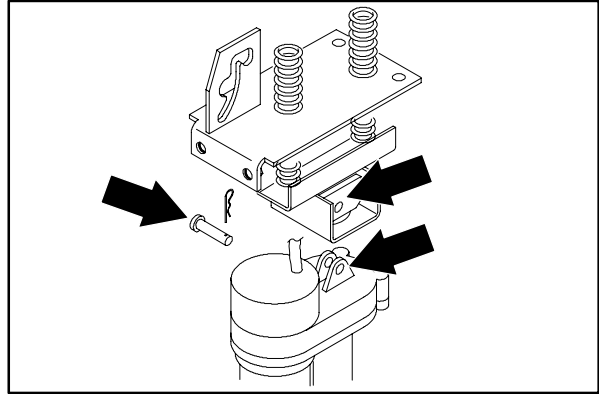

10. Position the new actuator and spring mount bracket in the machine. Slide the assembly down into the mount bracket. Route the wires and plug in the connector. Make sure the wires are located in the slot on the of the actuator bracket before installing the spring mount bracket.

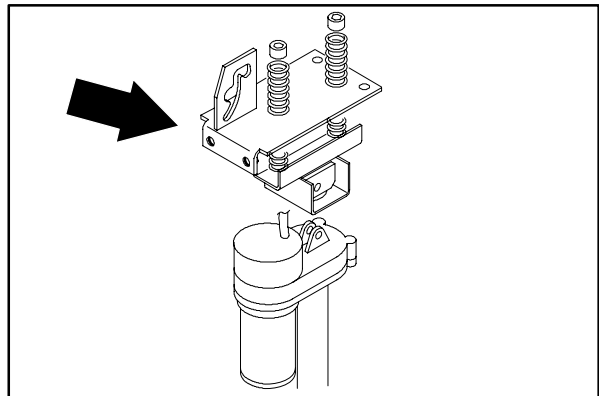

11. Reinstall the two screws in the spring mount bracket. Leave loose for now.

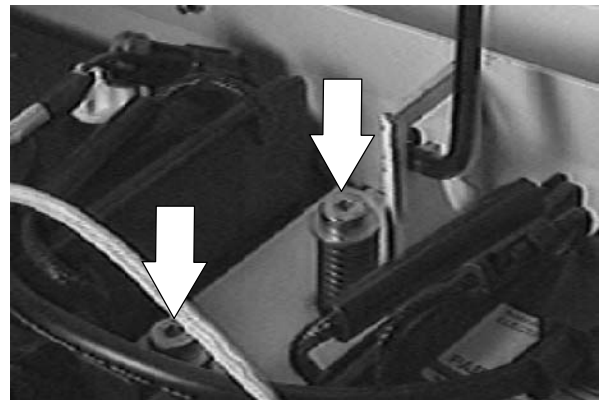

12. Go around to the front of the seat support and install the two screws that hold the front of the spring mount bracket to the seat support. Tighten all four screws to 18 - 24 Nm (15 - 20 ft lb).

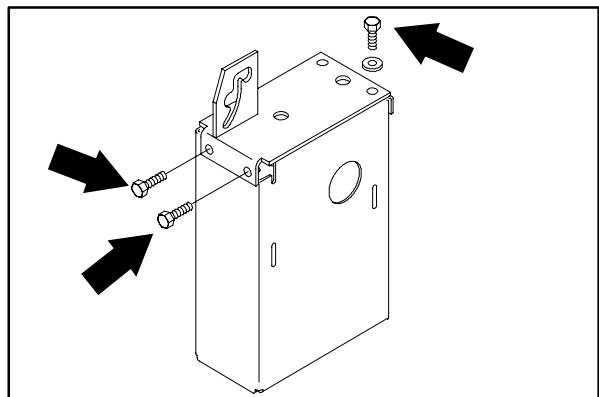

# T15 Maintenance & Repair

13. Reinstall the prop rod in the bracket and on the bottom of the seat support. Snug the screws and nut so the rod can still pivot.

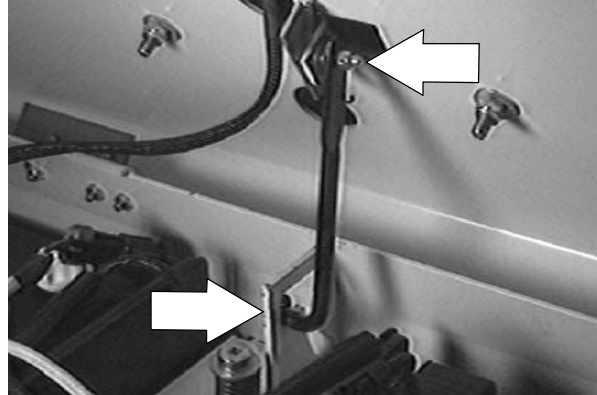

14. Go in on top of the scrub head and install the clevis and cotter pin in the bottom of the scrub head lift actuator tube and scrub head lift bracket.

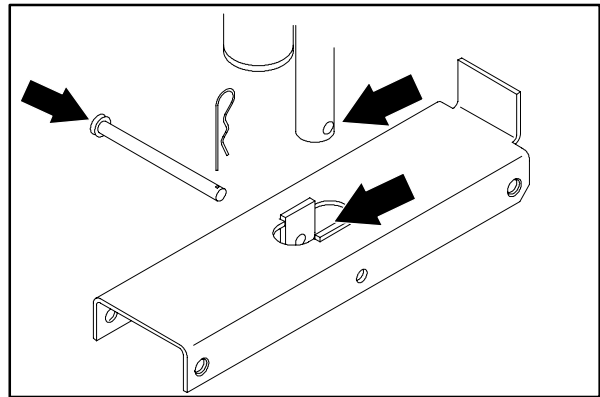

15. Raise the seat support and plug in the battery connector. Lower the seat assembly.

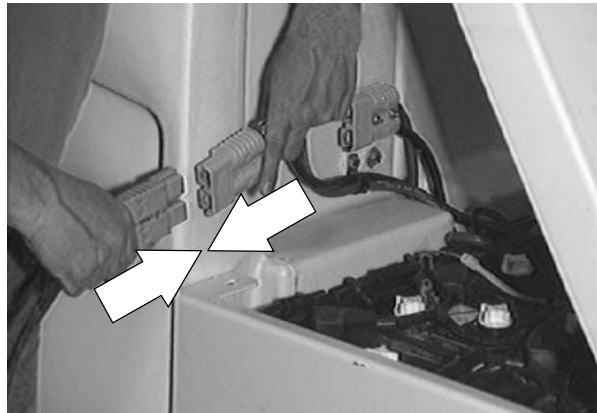

16. Operate the machine and check the scrub head lift actuator for proper operation.



# T15 Maintenance & Repair

---

## SOLUTION SYSTEM

---

### RECOVERY TANK

The recovery tank holds recovered solution. Clean and drain the recovery tank after each use. The outside of the tank can be cleaned with vinyl cleaner.

ES mode: Flush out the recovery tank with clean water. Rinse the filter and the sensor floats near the top of the tank.

**NOTE: *DO NOT* use steam to clean the tanks. Excessive heat can damage the tanks and components.**



Thoroughly rinse the sensor floats inside the recovery tank after each use.



# T15 Maintenance & Repair

## TO REMOVE RECOVERY TANK

**FOR SAFETY: Before Leaving Or Servicing Machine; Stop On Level Surface, turn key switch OFF.**

1. In order to remove the recovery tank, the solution tank hardware must be loosened or removed first. See TO REMOVE SOLUTION TANK instructions.
2. Tilt the seat support until the prop rod is engaged.
3. If the machine is equipped with an overhead guard--it must be removed.



4. Make sure the recovery tank is drained and the tank clean out caps removed.

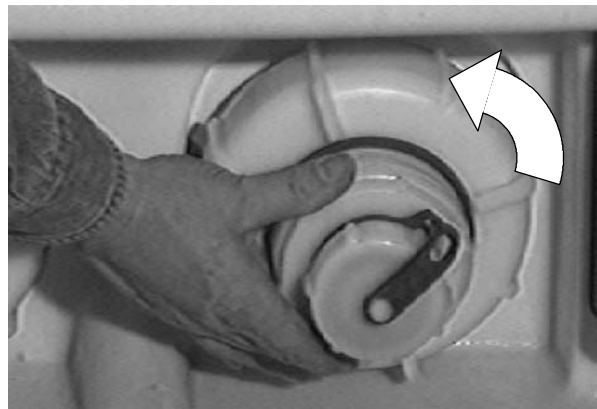

5. Remove the four hex screws holding the plastic, rear drain splash tray. Let it drop down for access to the recovery tank hardware.

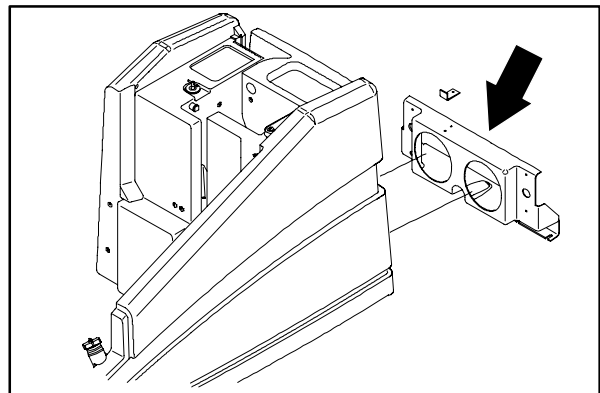

# T15 Maintenance & Repair

6. Remove the screw on the left side of the solution tank drain cap.

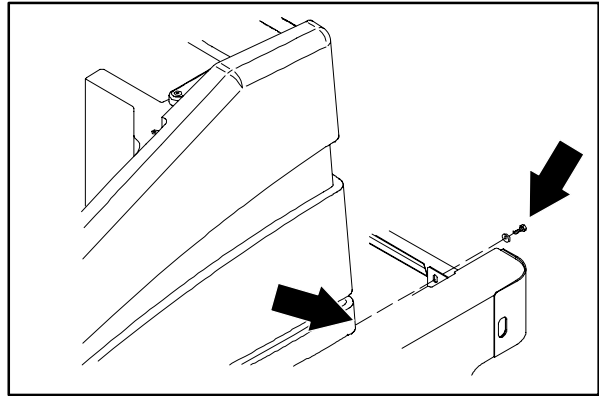

7. Open the tank cover. Remove the hardware holding the top of the prop arm to the tank cover.

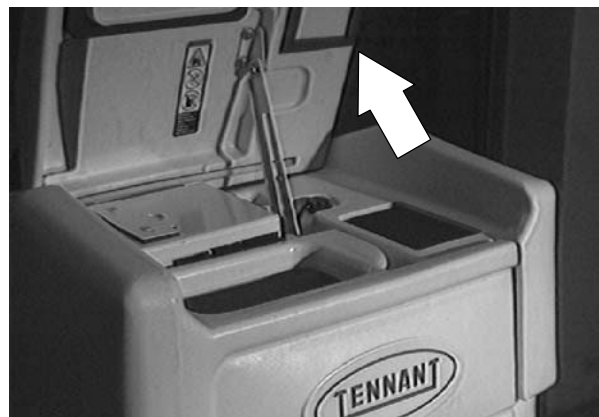

8. Pull the vacuum hose out of the hole in the recovery tank.

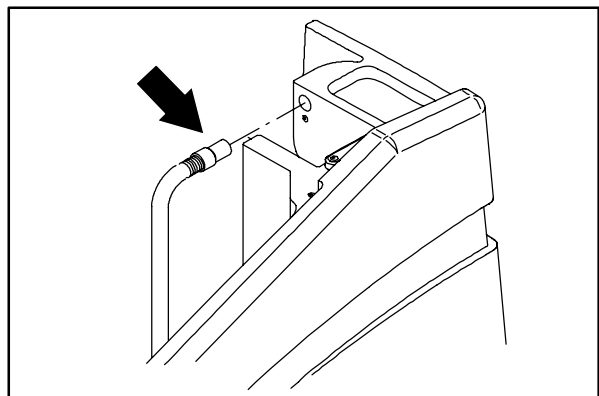

9. Remove the plastic tank cover hinge rod. Remove the tank cover from the machine.

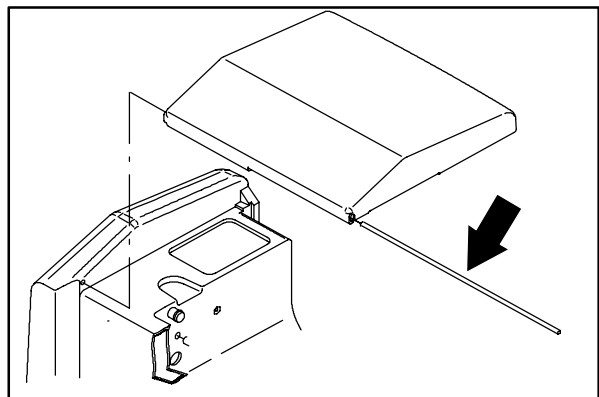



# T15 Maintenance & Repair

10. Remove the two screws holding the vacuum fan to the top of the recovery tank. Pull the vacuum fan up and disconnect the electrical plug. Remove the vacuum fan from the machine.

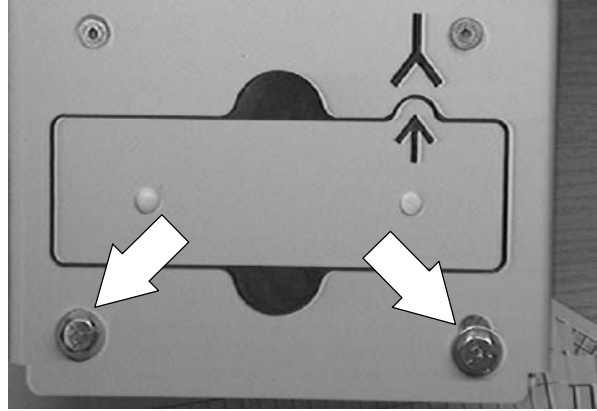

11. Remove the hardware holding the air flush valve and bracket to the recovery tank.

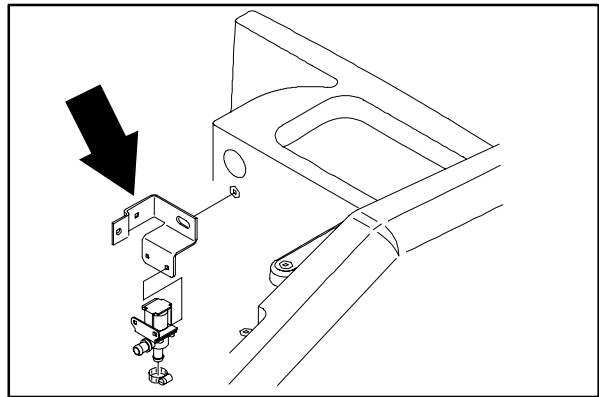

12. Go in the operators compartment and remove the screw from the left, front corner of the recovery tank.

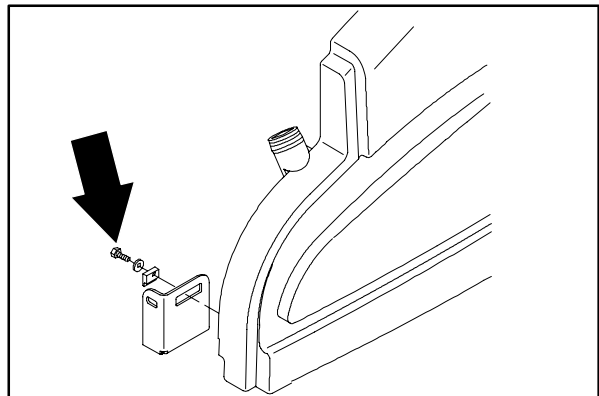

13. Pull the recovery tank up far enough to access the ES™ hose on the inside wall. Remove the hose from the recovery tank.

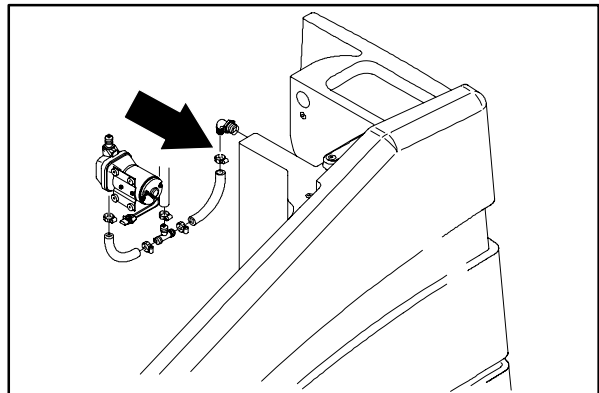

# T15 Maintenance & Repair

14. Disconnect the float switch electrical plug from the main harness.

*NOTE: Make sure to note the orientation of the electrical harness before removing the solution tank. It is very important to position the harness in the same location when installing a new tank.*

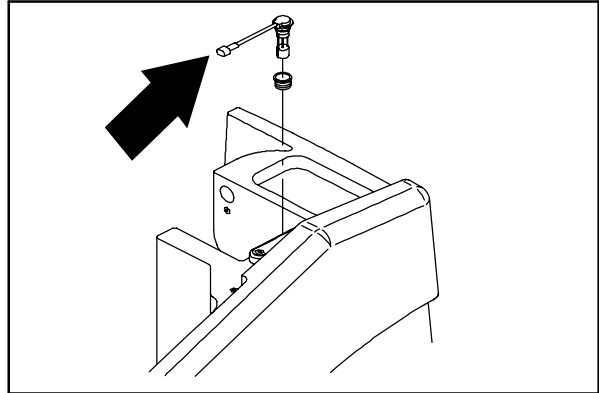

15. The recovery tank can now be removed from the machine.

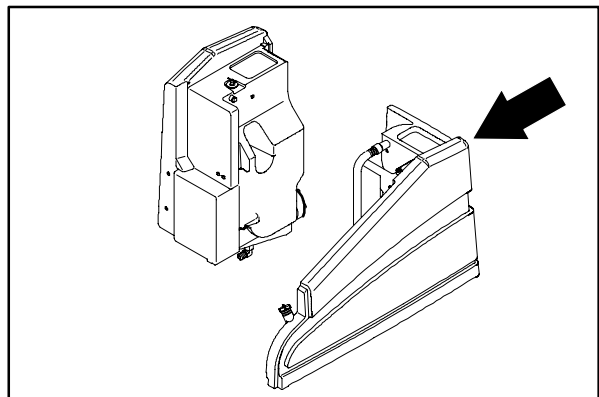

# T15 Maintenance & Repair

## TO INSTALL RECOVERY TANK

**FOR SAFETY: Before Leaving Or Servicing Machine; Stop On Level Surface, turn key switch OFF.**

1. Position the recovery tank on the left side edge of the machine frame.

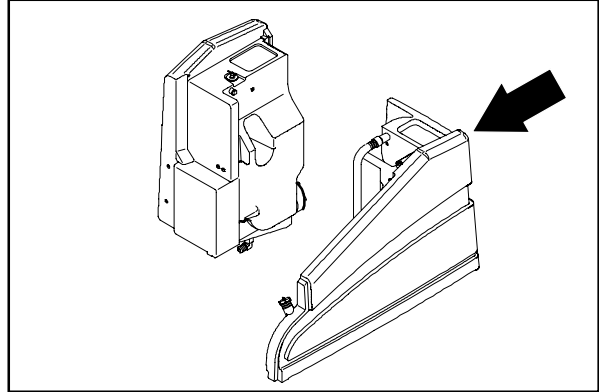

2. Connect the hose coming from the ES™ pump to the nipple on the side of the recovery tank. Tighten the worm drive clamp.

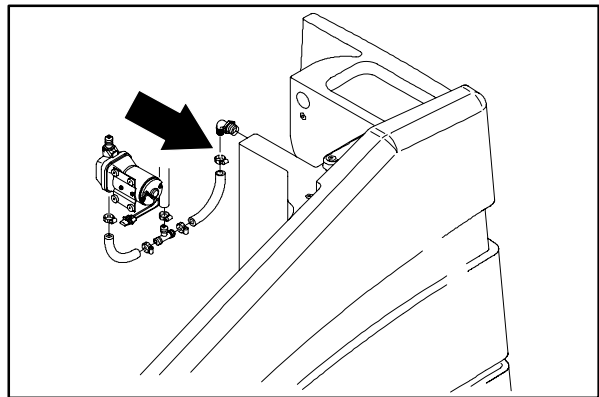

3. Drop the recovery tank down in place. Be careful to route the electrical harness properly.

4. Move the tank around until the front and back mount holes in are lined up with the holes in the frame.

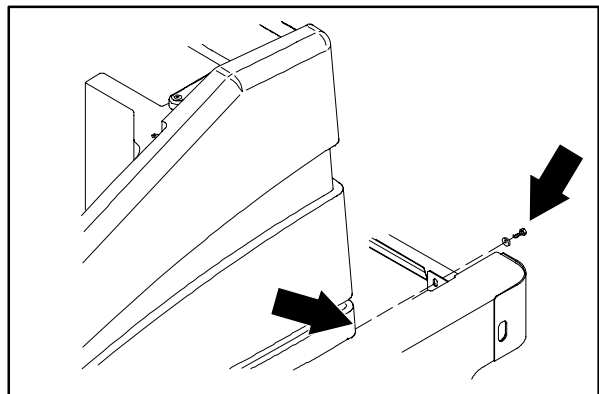

5. Install the hex screw in the area to the left of the tank drain cap. Leave loose for now.

# T15 Maintenance & Repair

6. Install the screw holding the left front of the recovery tank to the frame in the area of the operators compartment. Leave loose for now.

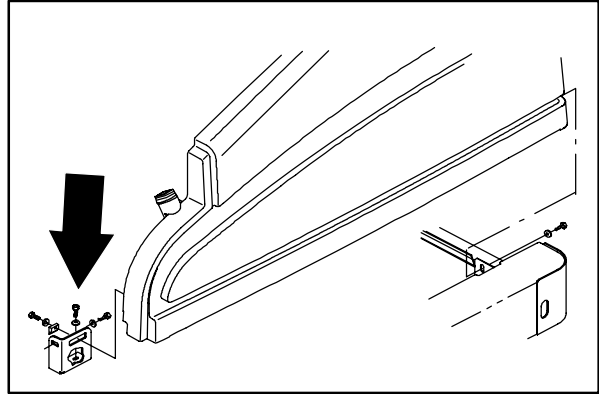

7. Install the air flush valve mount bracket on the front of the recovery tank. Tighten all three screws to 18 - 24 Nm (15 - 20 ft lb).

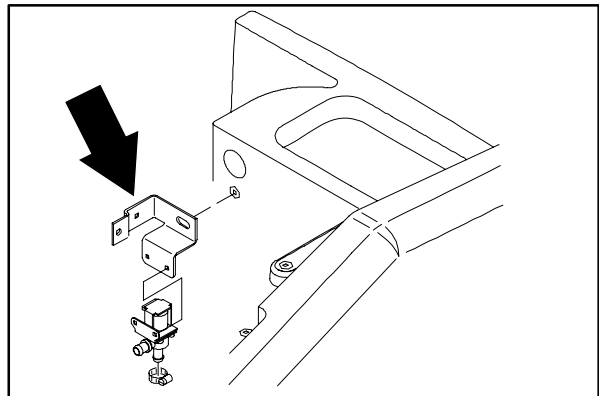

8. Reinstall the vacuum fan on the recovery tank. Reconnect the vacuum fan to the main electrical harness. Tighten the hardware to 18 - 24 Nm (15 - 20 ft lb).

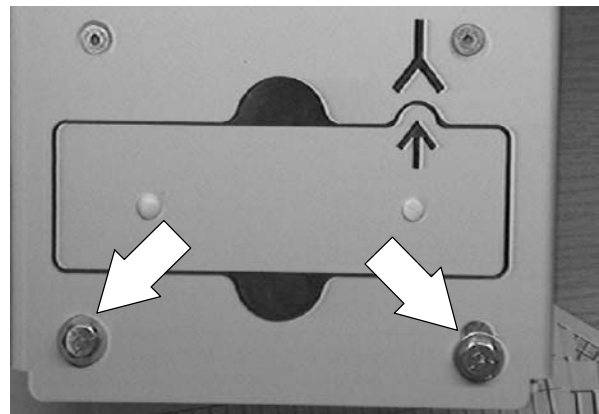

9. Reinstall the tank cover and plastic hinge rod.

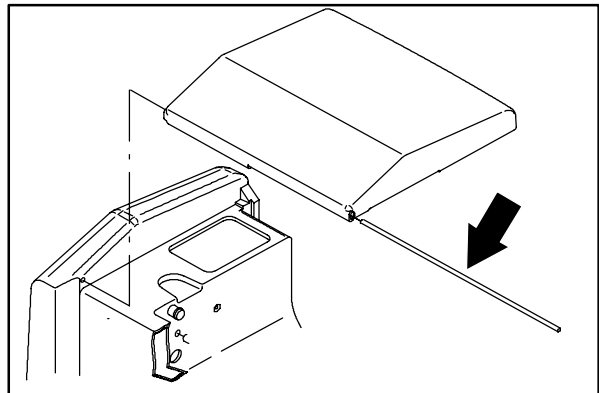

# T15 Maintenance & Repair

10. Reconnect the top of the prop arm to the tank cover.



11. Reinstall the plastic, rear drain splash tray over the tank drains. Tighten the four screws.

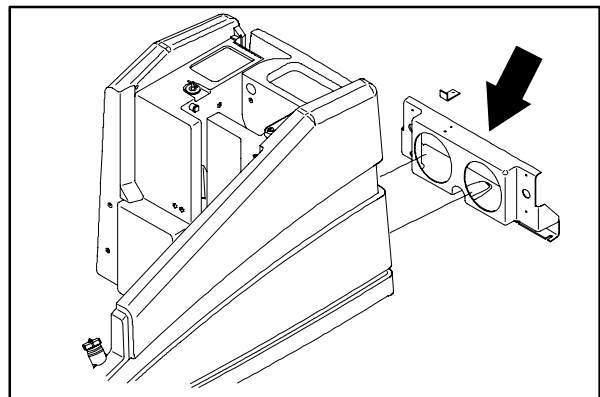

12. Reinstall the tank drain hose and caps.

13. Reinstall the overhead guard if it was removed earlier.

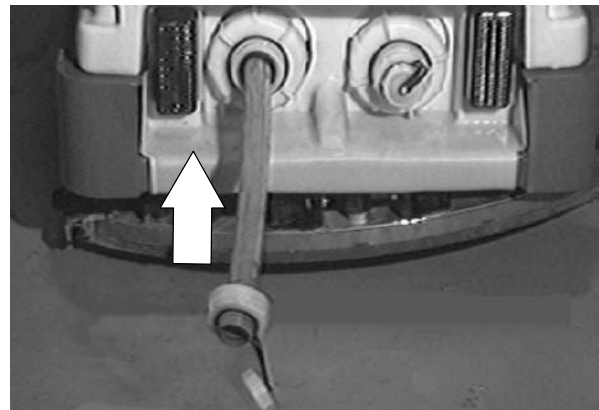

14. Operate the machine and check the recovery tank for any leaks and for proper operation of the float switch.



# T15 Maintenance & Repair

## SOLUTION TANK

The solution tank holds the cleaning solution.

If deposits form on the bottom of the tank, rinse the tank and with a strong blast of warm water.

ES option: The solution tank should be drained and cleaned daily. Rinse the sensor float near the top of the solution tank off with a hose after each use.

The solution tank contains one standard solution filter. If the filter becomes dirty, the solution flow will be reduced. Check and clean this filter regularly.

**NOTE:** ***DO NOT** use steam to clean the tanks. Excessive heat can damage the tanks and components.*



# T15 Maintenance & Repair

## TO REMOVE SOLUTION TANK

**FOR SAFETY: Before Leaving Or Servicing Machine; Stop On Level Surface, turn key switch OFF.**

1. In order to remove the solution tank, the recovery tank must be removed first. See TO REMOVE RECOVERY TANK instructions.
2. Remove the seat assembly. See TO REMOVE SEAT ASSEMBLY instructions in CHASSIS section.



3. Disconnect the battery plug from the batteries. Remove the two screws holding the battery connector bracket to the front of the solution tank.

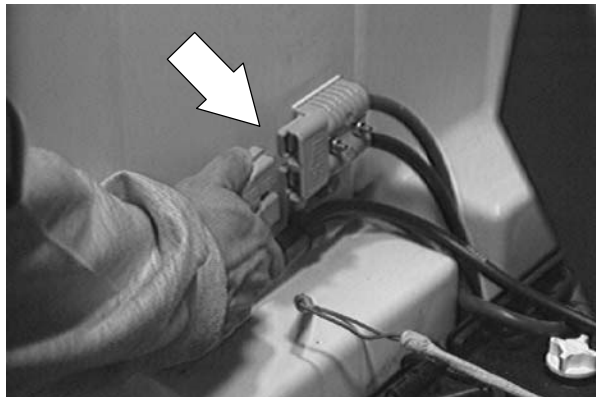

4. Remove the battery nearest the right, rear corner of the battery compartment.

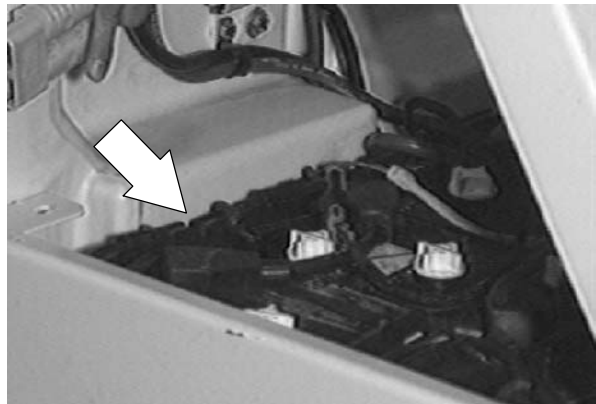

# T15 Maintenance & Repair

5. Remove the two screws holding the front of the solution tank to the seat support.
6. If the machine is equipped with an overhead guard--it must be removed.

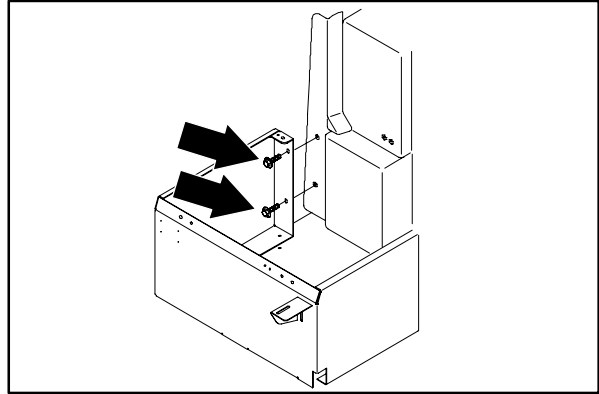

7. Make sure the solution tank is drained and the tank clean out caps removed.

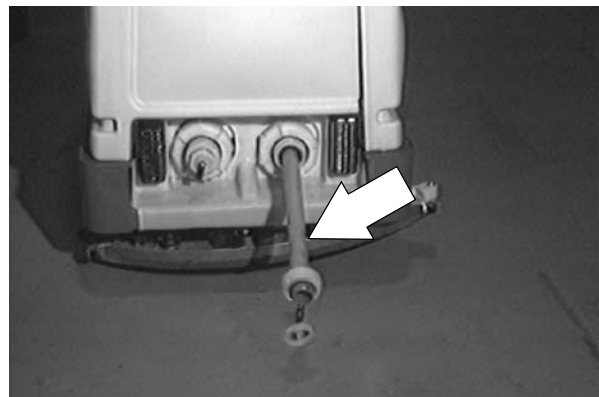

8. Remove the four hex screws holding the plastic, rear drain splash tray. Let it drop down for access to the solution tank hardware.

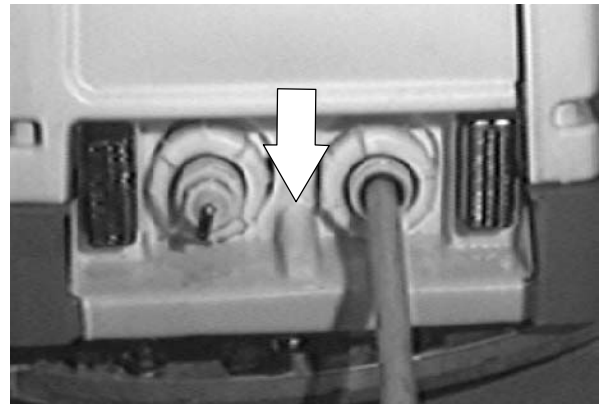

9. Remove the screw on the right side of the solution tank drain cap.

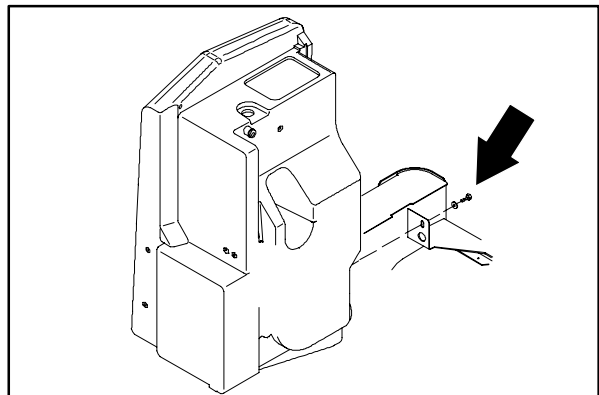



# T15 Maintenance & Repair

10. Open the tank cover. Remove the hardware holding the top of the prop arm to the tank cover.
11. Remove the plastic tank cover hinge rod. Remove the tank cover from the machine.

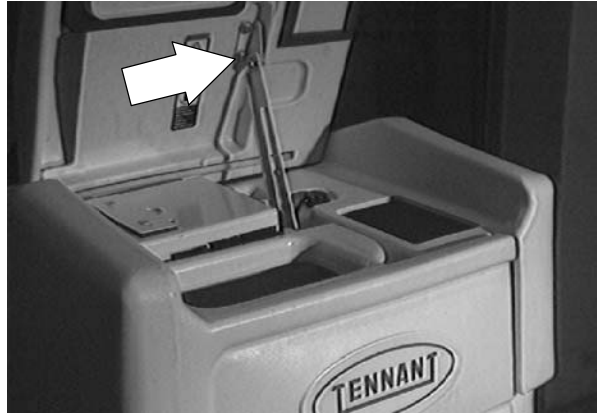

12. Remove the hardware holding the air flush valve and bracket to the solution tank.

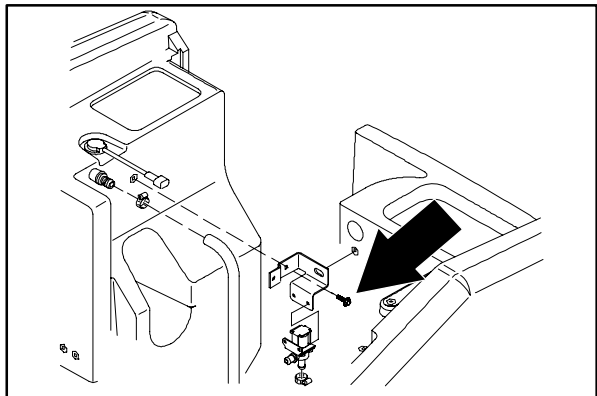

13. Disconnect the clear water hose from the top, front corner of the solution tank.

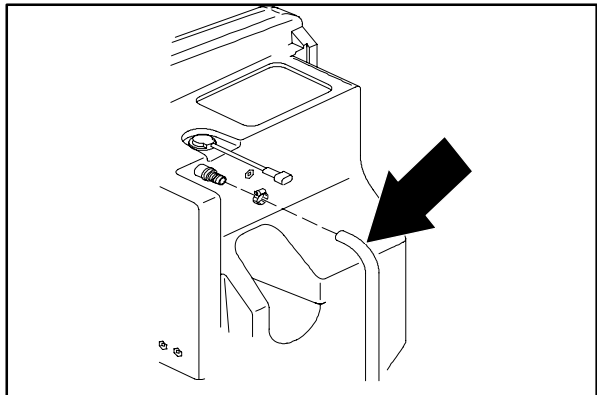

14. Disconnect the float switch electrical plug from the main harness.

**NOTE:** Make sure to note the orientation of the electrical harness before removing the solution tank. It is very important to position the harness in the same location when installing a new tank.

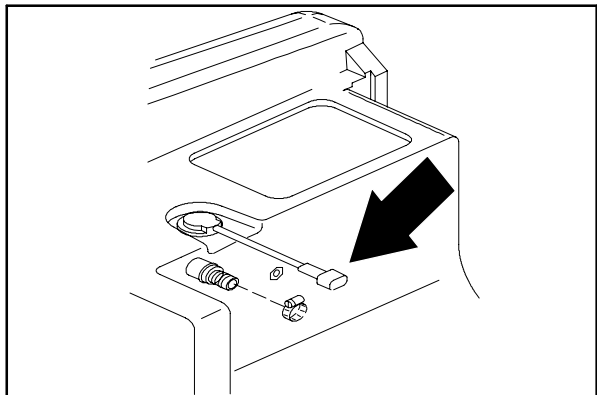

## T15 Maintenance & Repair

15. Lift the solution tank up far enough to access the clamp on the hose running from the bottom of the solution tank to the water valve. Loosen this clamp and remove the hose from the solution tank.

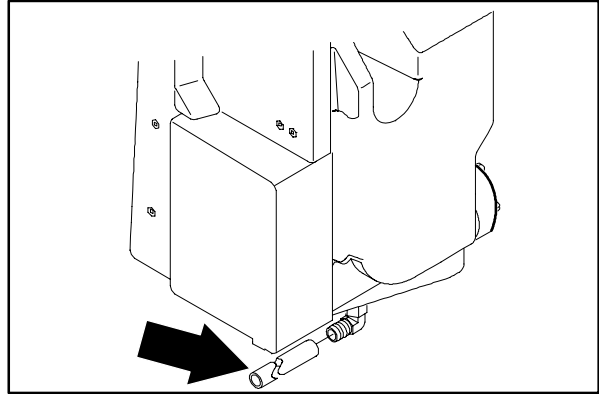

16. The solution tank can now be removed from the machine.



# T15 Maintenance & Repair

## TO INSTALL SOLUTION TANK

**FOR SAFETY: Before Leaving Or Servicing Machine; Stop On Level Surface, turn key switch OFF.**

1. Position the solution tank on the right side edge of the machine frame.

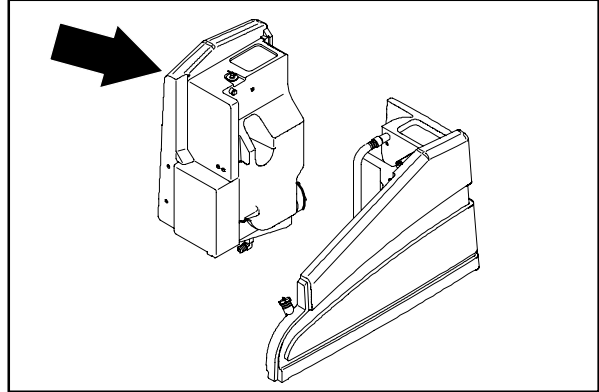

2. Connect the hose coming from the water valve to the nipple on the bottom of the solution tank. Tighten the worm drive clamp.
3. Drop the solution tank down in place. Be careful to route the electrical harness properly.
4. Move the tank around until all the mount holes in the tank are lined up with the holes in the frame.

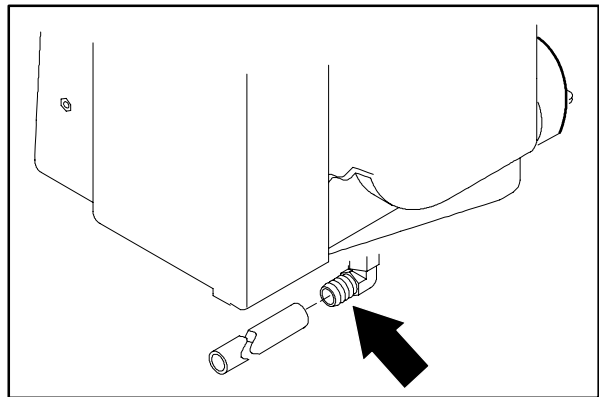

5. Install the hex screw in the area to the right of the tank drain cap. Leave loose for now.

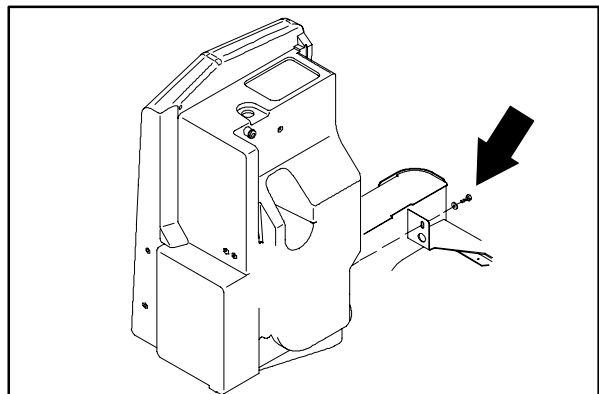

# T15 Maintenance & Repair

6. Install the two screws holding the front of the solution tank to the seat support. Leave loose for now.

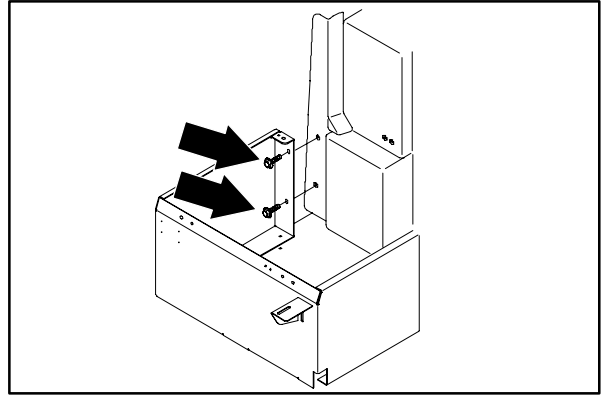

7. Install the air flush valve mount bracket on the side of the solution tank. Tighten all four screws to 18 - 24 Nm (15 - 20 ft lb).

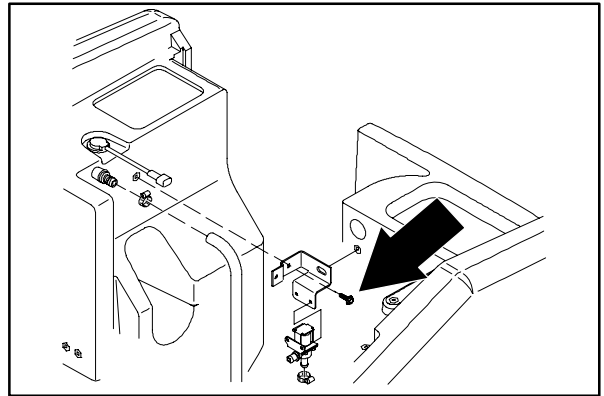

8. Connect the water hose to the top, front nipple on the solution tank. Tighten the worm drive clamp.

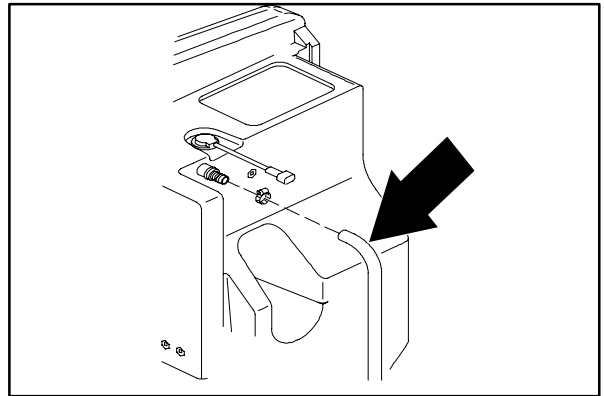

9. Connect the float switch to the main harness.

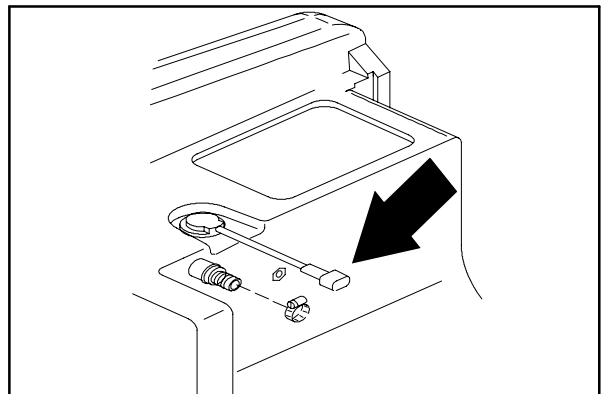

# T15 Maintenance & Repair

10. Reinstall the tank cover and plastic hinge rod.

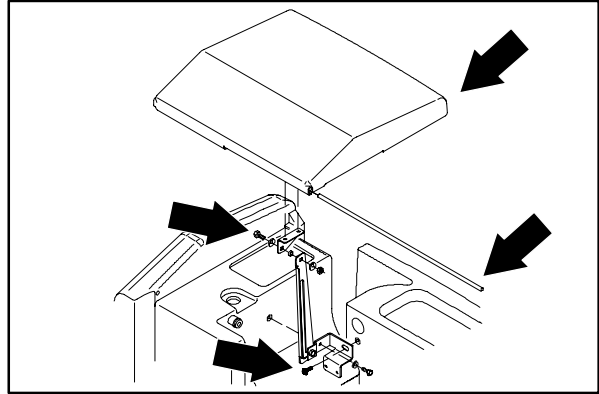

11. Reconnect the top of the prop arm to the tank cover.

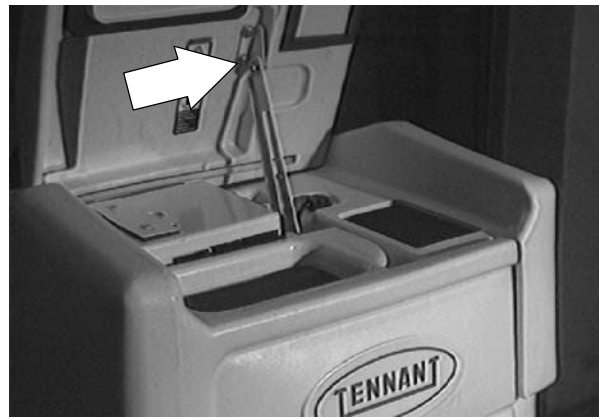

12. Reinstall the plastic, rear drain splash tray over the tank drains. Tighten the four screws.

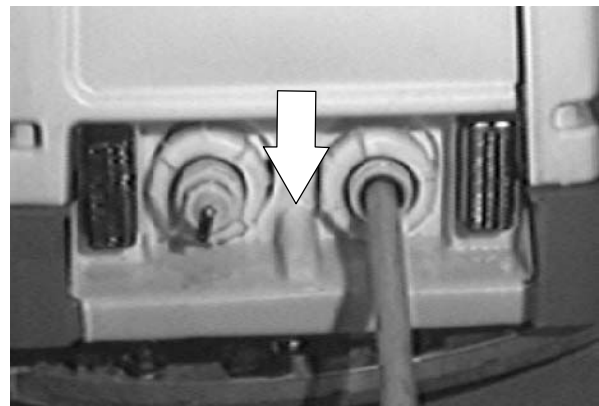

13. Reinstall the tank drain hose and caps.

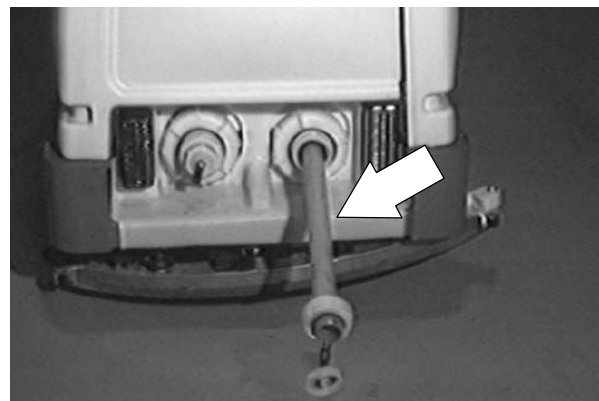

## T15 Maintenance & Repair

14. Reinstall the battery in the right, rear corner of the battery compartment.

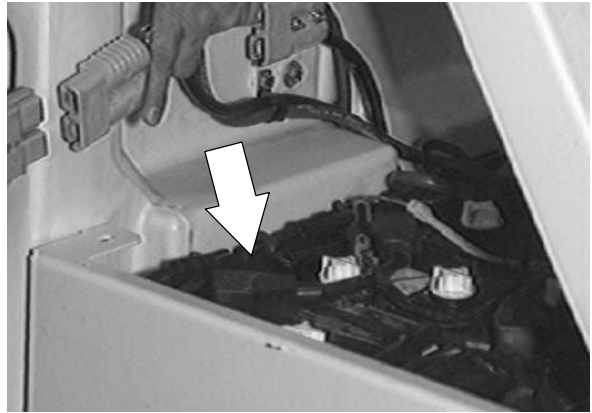

15. Reinstall the battery connector mount bracket on the front of the solution tank. Tighten the two screws to 18 - 24 Nm (15 - 20 ft lb).

16. Reinstall the overhead guard if it was removed earlier.

17. Operate the machine and check the solution tank for any leaks and for proper operation of the float switch.

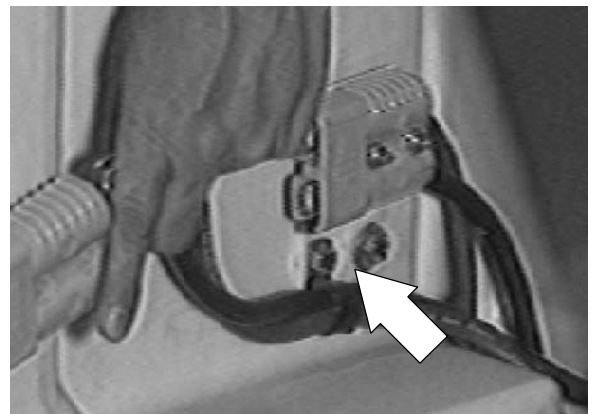

M

# T15 Maintenance & Repair

---

## MANUAL SOLUTION VALVE

---

The manual solution valve is located under the floor plate on the left side of the machine. This valve controls the amount of water being sent to the scrub brushes. The control lever is located in the operators compartment, next to the operators left leg.

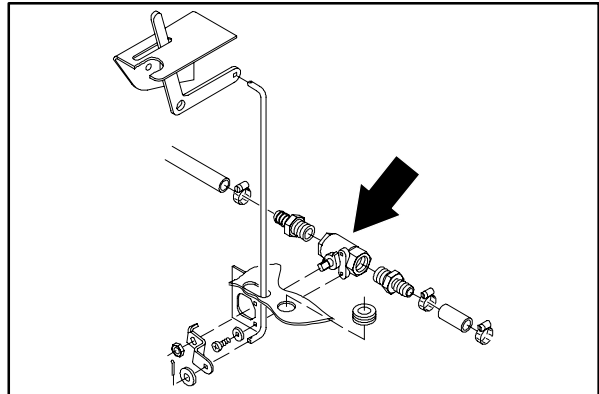

## TO REPLACE SOLUTION VALVE

1. Drain the solution tank.

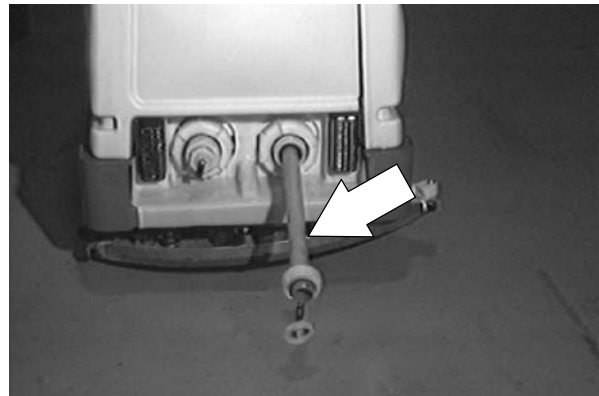

2. Lower the scrub head to the floor.

**FOR SAFETY: Before Leaving Or Servicing Machine; Stop On Level Surface, turn key switch OFF.**



# T15 Maintenance & Repair

3. Go under the machine on the left side.
4. Locate the manual solution valve above the scrub head.

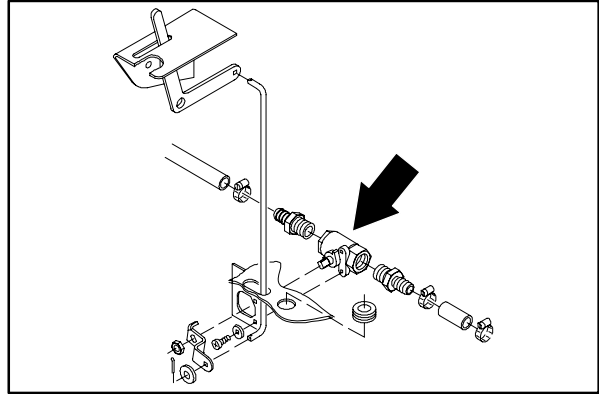

5. Remove the cotter pin from the control lever rod where it attaches to the valve. Pop the rod out of the mount hole.

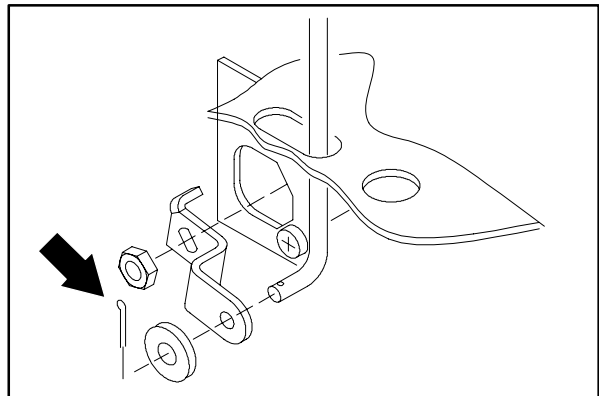

6. Loosen the worm drive clamps holding the two solution hoses to the valve fittings. Pull the hoses off the fittings.

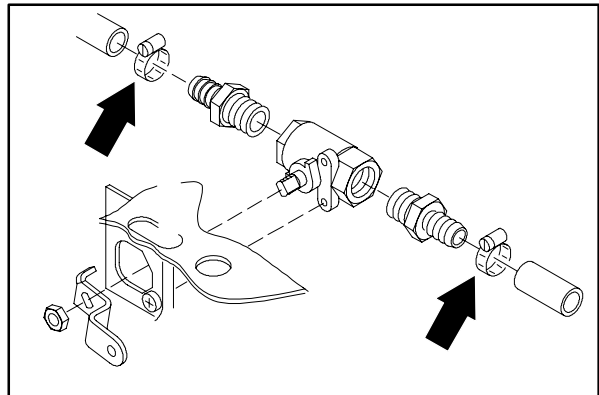

7. Remove the two screws holding the valve to the machine frame. Remove the manual valve from the machine.

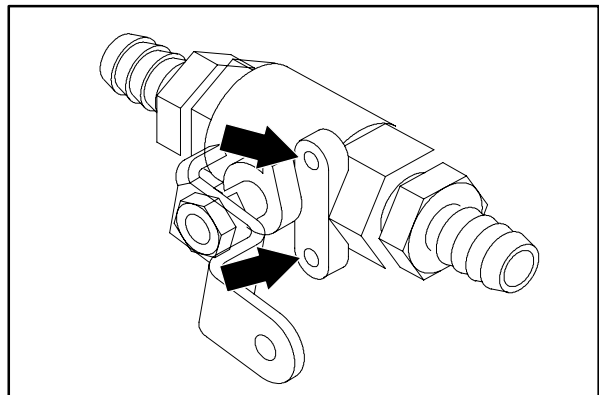



# T15 Maintenance & Repair

8. Remove the fittings from the old valve and install in the new valve in the same orientation.

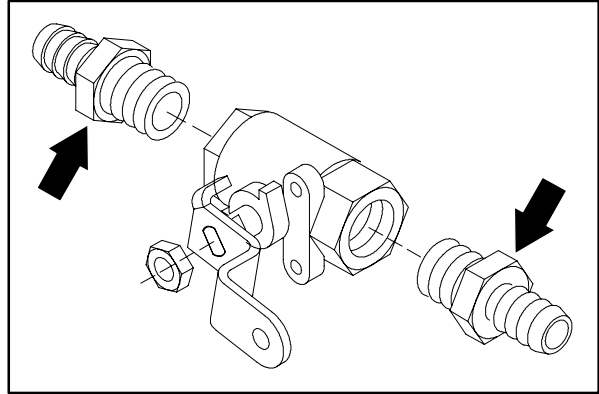

9. Remove the lever from the old valve and install it on the new valve in the same orientation.

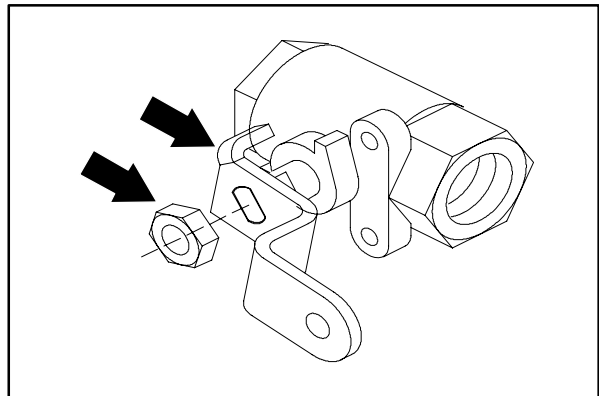

10. Install the new valve on the machine. Hand tighten the screws.

11. Reconnect the two solution hoses. Hand tighten the worm drive clamps.

12. Place the control lever rod in the mount hole and install the cotter pin.

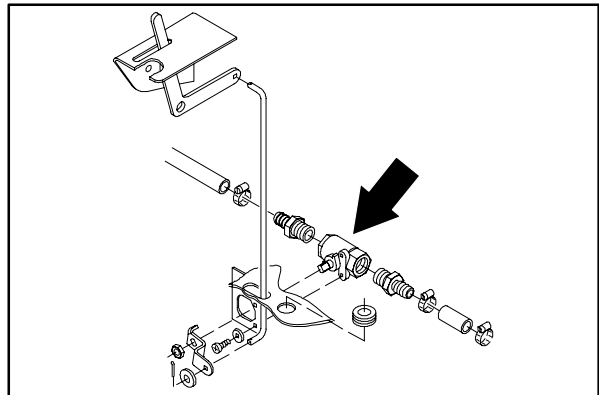

13. Operate the machine and check the water valve for proper operation.

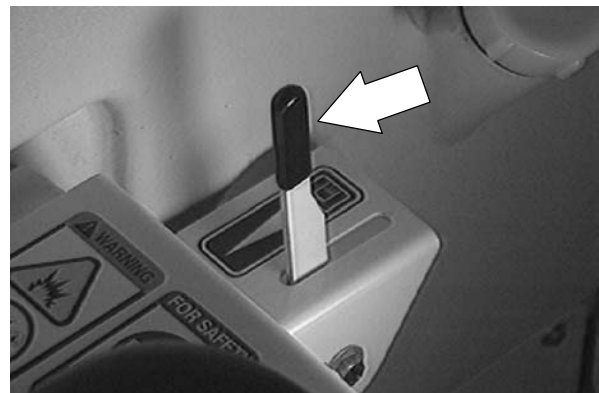

# T15 Maintenance & Repair

---

## SOLUTION SOLENOID VALVE

---

The solution solenoid valve is used to start and stop the flow of water to the scrub head when the machine is either propelling forward or in neutral. This valve is used along with the manual valve, which controls the amount of water that flows to the scrub head.

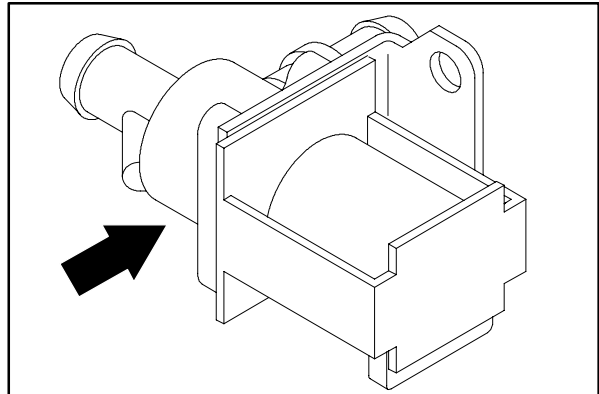

## TO REPLACE SOLUTION SOLENOID VALVE

1. Drain the solution and recovery tanks.

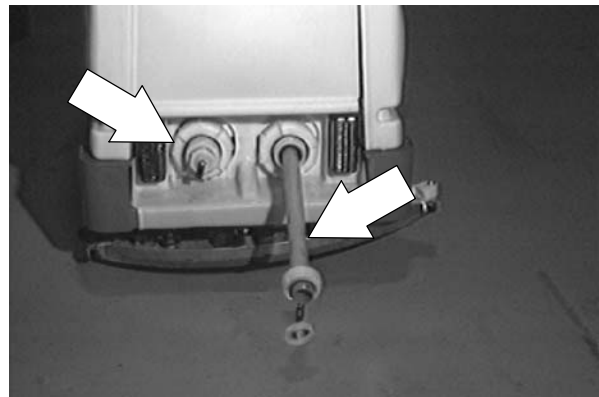

2. Start the machine and lower the scrub head.  
Turn off the key.

**FOR SAFETY: Before Leaving Or Servicing Machine; Stop On Level Surface, turn key switch OFF.**



# T15 Maintenance & Repair

3. Go under the machine on the left side, in front of the rear tire.



4. Locate the solution solenoid valve in the area of the manual valve.

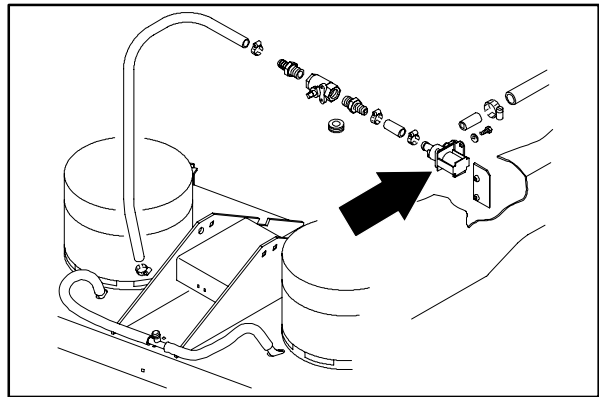

5. Mark and disconnect the wires leading to the solenoid valve.

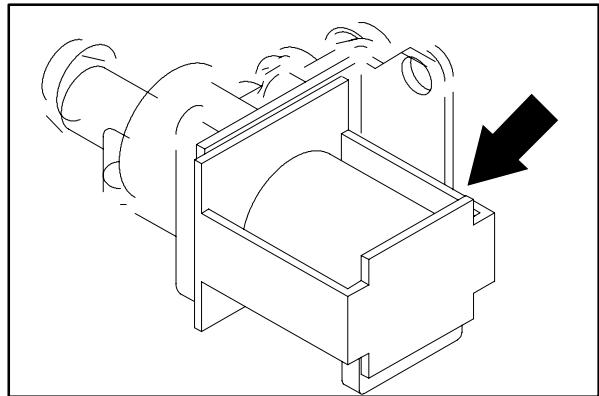

6. Loosen the two worm drive clamps holding the water hoses to the valve. Mark the hoses and pull them off the fittings.

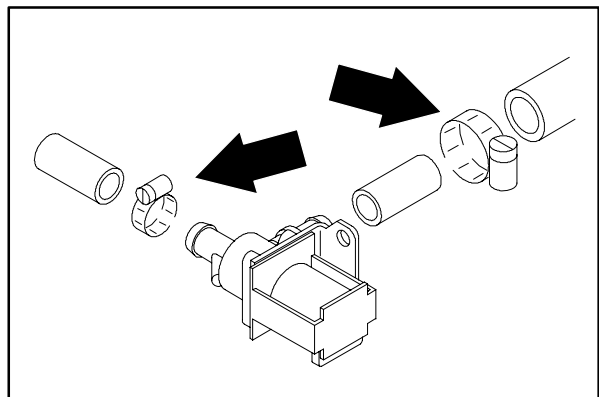

# T15 Maintenance & Repair

7. Remove the two screws holding the valve to the machine frame. Remove the valve from the machine.

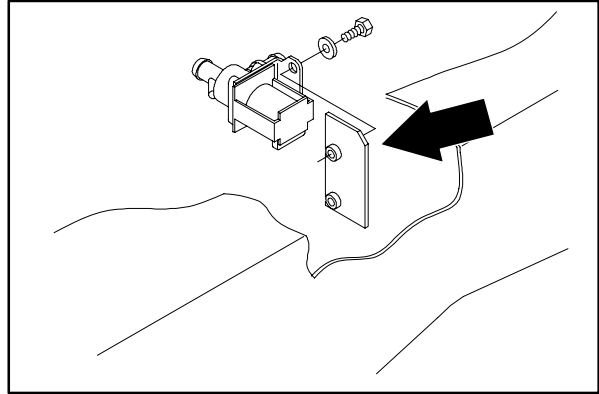

8. Position the new solenoid valve in the machine. Reinstall the hardware and lightly hand tighten.

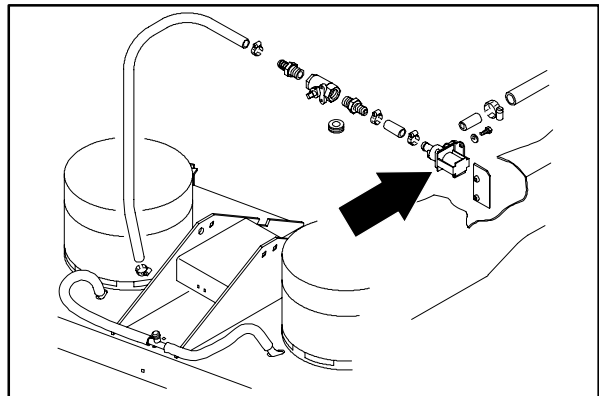

9. Re-connect the two water hoses to the new valve. Hand tighten the two worm drive clamps.

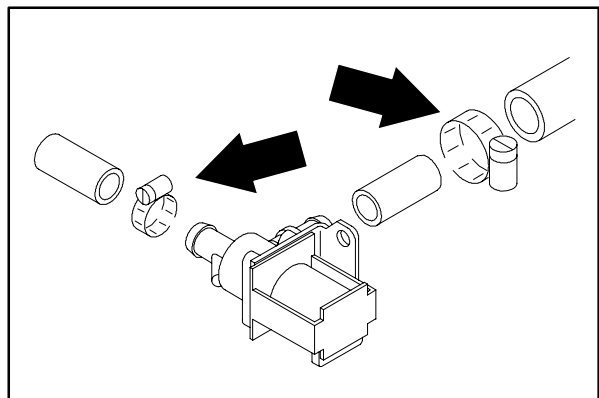

10. Re-connect the wires to the new solenoid valve. See schematic in the section.
11. Start the machine and operate. Check the new valve for proper operation.



# T15 Maintenance & Repair

---

## FaST SYSTEM

---

### FaST SUPPLY HOSE CONNECTOR

The FaST supply hose connector is located below the FaST PAK holder. Soak the connector in warm water if detergent buildup is visible. When a FaST PAK carton is not installed, store the supply hose connector on the storing plug to prevent the hose from clogging.

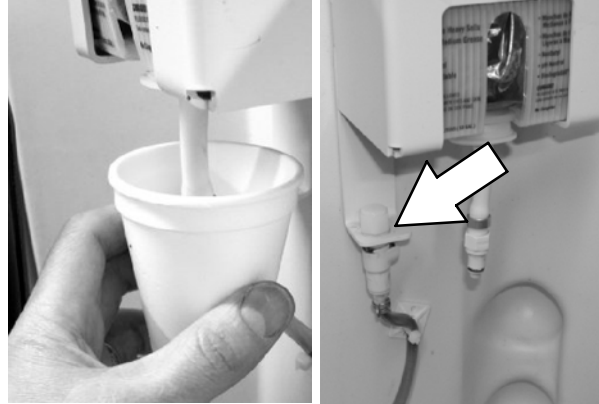

### FaST / SOLUTION FILTER SCREEN

The FaST / solution filter screen is located under the machine. It filters the water from the solution tank as it flows into the FaST system.

Remove the filter screen bowl and clean the filter screen after every 50 hours of FaST scrubbing. Empty the solution tank before removing the filter.

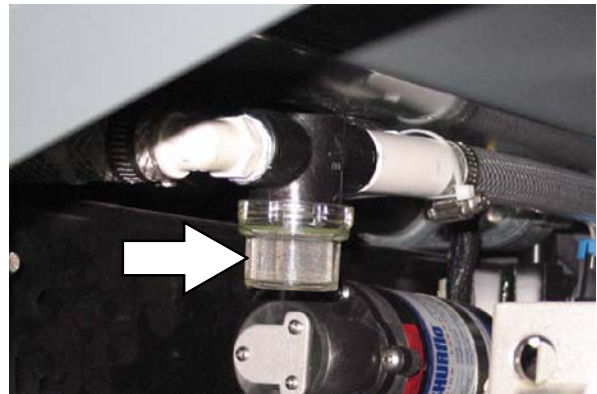

# T15 Maintenance & Repair

---

## ES™ PUMP

---

### TO REPLACE ES™ PUMP

**FOR SAFETY: Before Leaving Or Servicing Machine; Stop On Level Surface, turn key switch OFF.**

1. Make sure the solution and recovery tanks are empty.

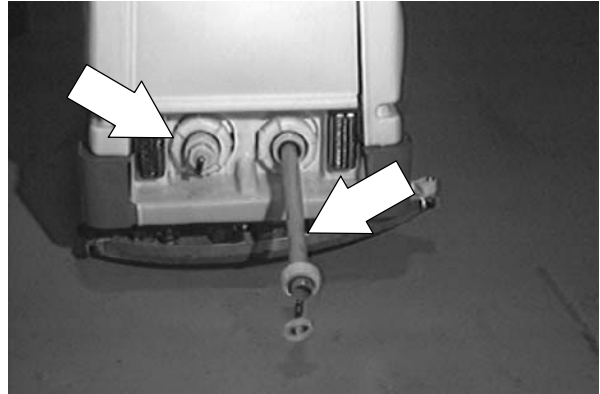

2. Remove the vacuum fan assembly. See TO REMOVE VACUUM FAN ASSEMBLY instructions.

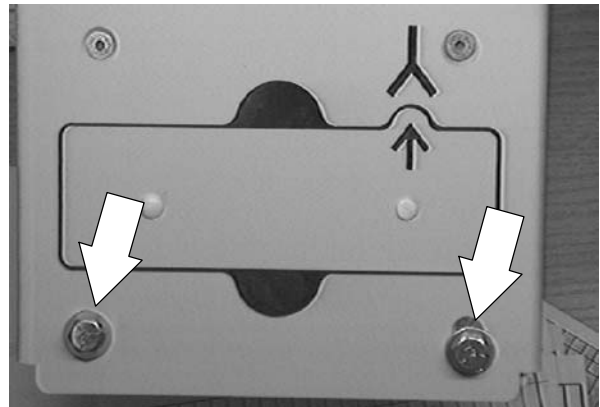

3. Locate the ES™ pump under the solution/recovery tanks, behind the rear squeegee mount frame.

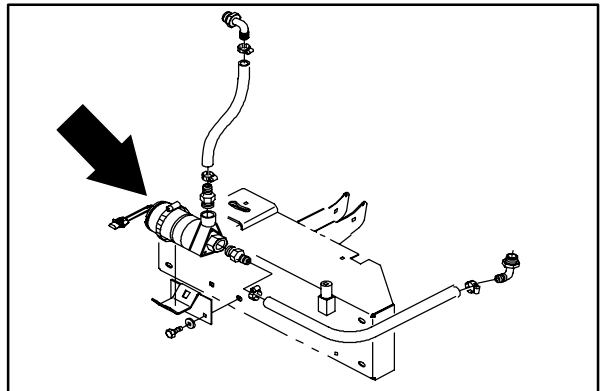

# T15 Maintenance & Repair

4. Disconnect the ES™ pump from the main electrical harness.

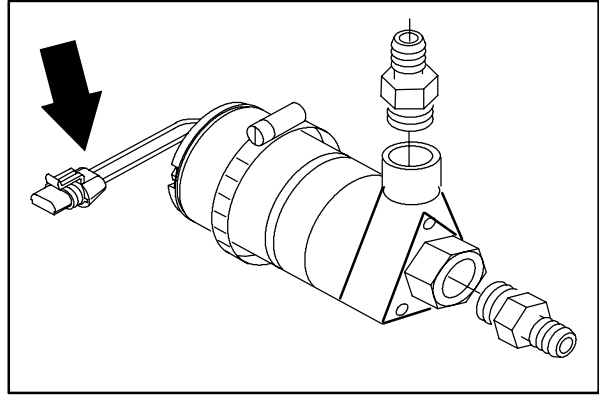

5. Loosen the worm drive clamps holding the solution hoses to the ES™ pump. Pull the hoses off the pump fittings.

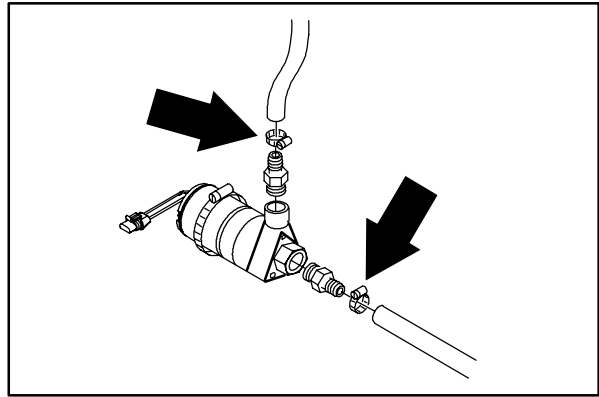

6. Loosen the large worm drive clamp holding the pump to the bracket.

7. Pull the ES™ pump assembly out of the machine.

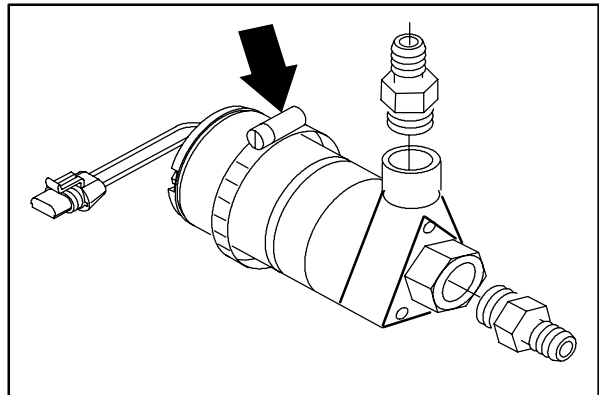

8. Remove the plastic fittings from the old pump and install in the new pump in the same orientation.

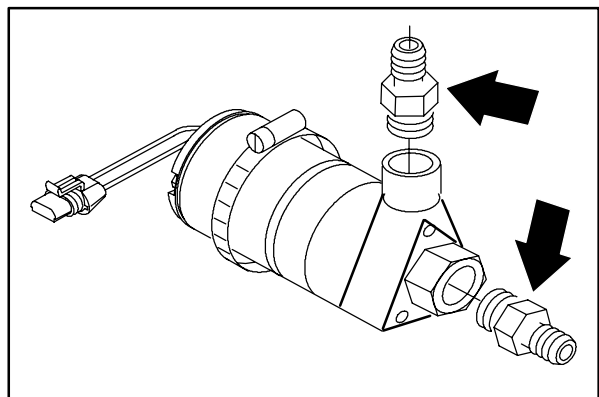

# T15 Maintenance & Repair

9. Install the new ES™ pump on the mount bracket. Reinstall the large worm drive clamp and hand tighten tight.

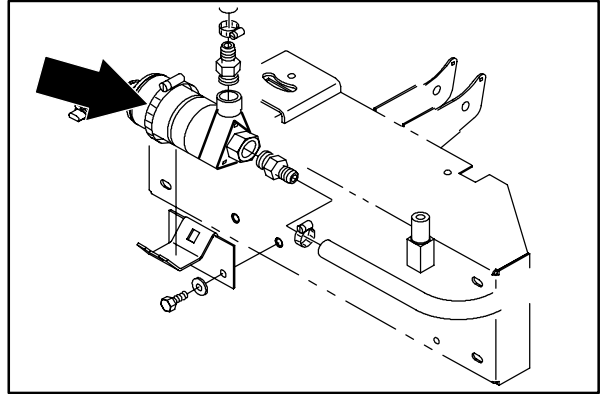

10. Place both solution hoses onto the pump fittings. Hand tighten the worm drive clamps.

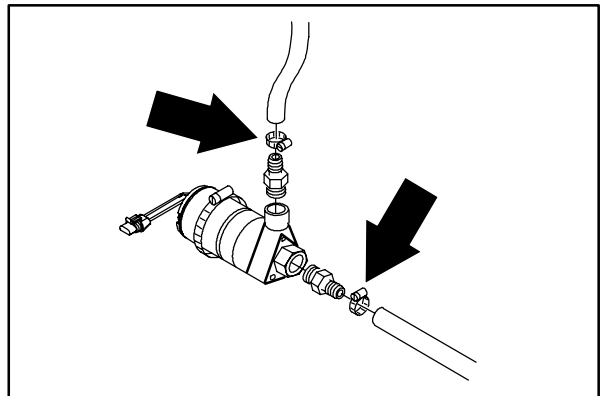

11. Reconnect the pump to the main electrical harness. See schematic in this section.

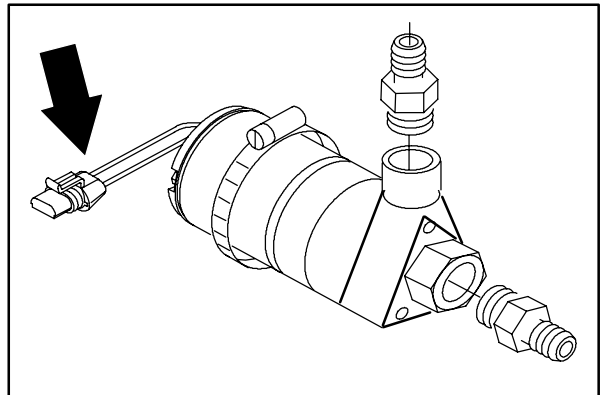

12. Reinstall the vacuum fan assembly. See TO INSTALL VACUUM FAN ASSEMBLY instructions.

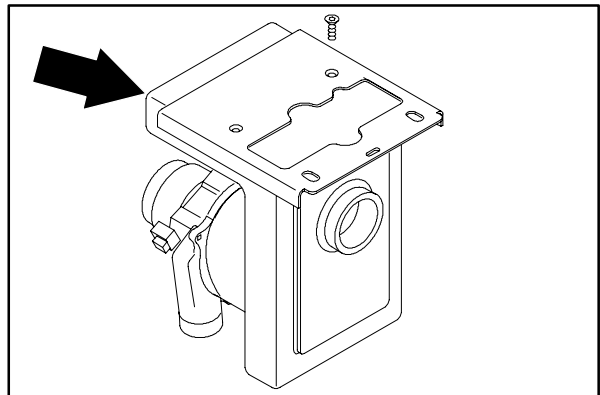

13. Operate the machine and check the ES™ pump for proper operation.





# T15 Maintenance & Repair

---

## SQUEEGEES

---

The rear squeegee assembly channels water into the vacuum fan suction. The front blade channels the water, and the rear blade wipes the floor.

Check the squeegee blades for damage and wear daily. Rotate or replace either of the squeegee blades if the leading edge is torn or worn half-way through the thickness of the blade.

The squeegee can be adjusted for leveling and deflection. The deflection and leveling of the squeegee blades should be checked daily, or when scrubbing a different type of floor.

The squeegee assembly can be removed from the squeegee pivot to prevent damage during transport of the machine.

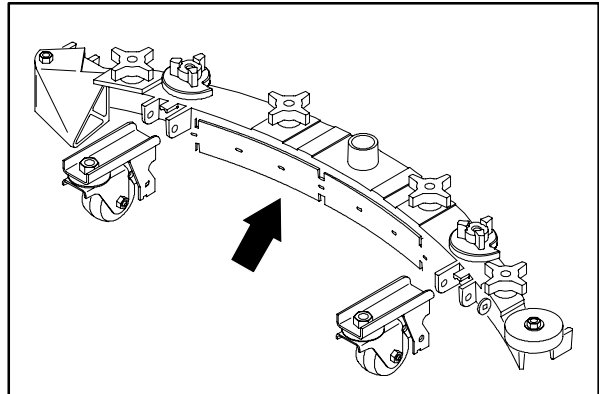

### TO REMOVE REAR SQUEEGEE ASSEMBLY

1. Lower the squeegee to approximately 25 mm (1 in.) from the floor.



2. Turn the machine power off and set the parking brake.

**FOR SAFETY: Before Leaving Or Servicing Machine; Stop On Level Surface, turn key switch OFF.**

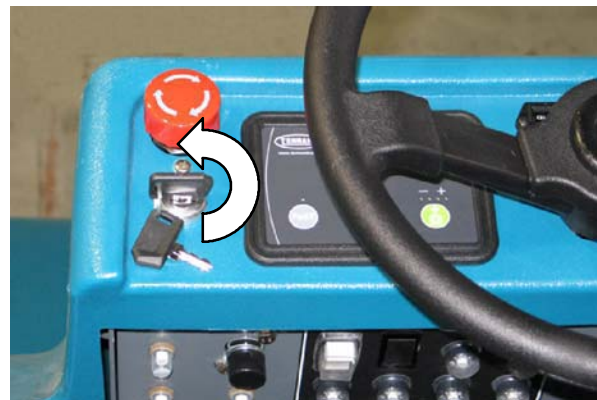

## T15 Maintenance & Repair

3. Remove the squeegee suction hose from the squeegee.

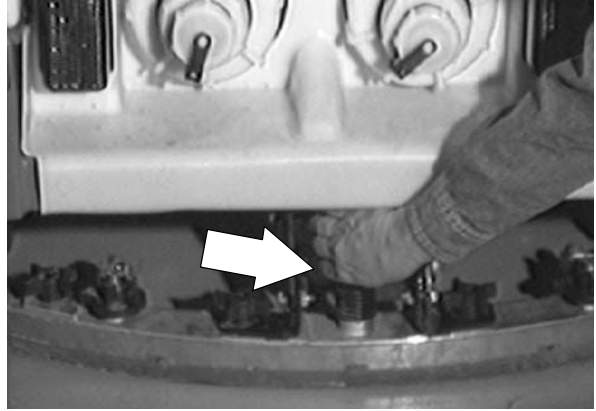

4. Remove both squeegee mounting knobs.

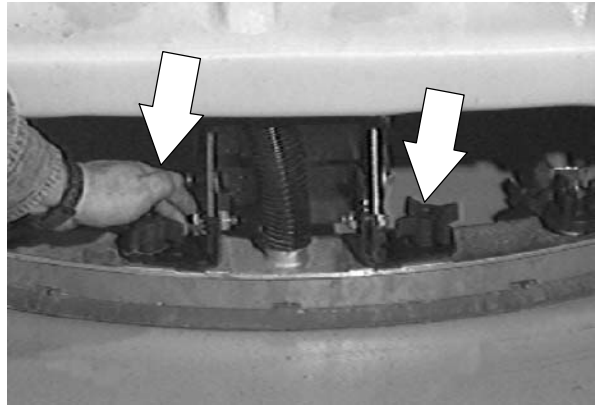

5. Pull the squeegee off the machine.

M

# T15 Maintenance & Repair

## TO INSTALL REAR SQUEEGEE ASSEMBLY

1. Make sure the squeegee pivot is lowered.

**FOR SAFETY: Before Leaving Or Servicing Machine; Stop On Level Surface, turn key switch OFF.**

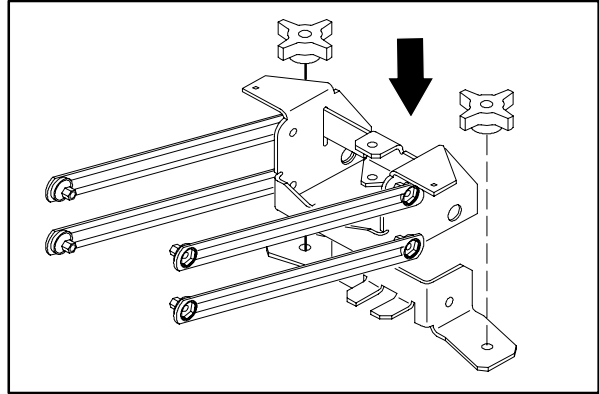

2. Place the squeegee under the squeegee pivot.
3. Push the squeegee frame onto the squeegee pivot.

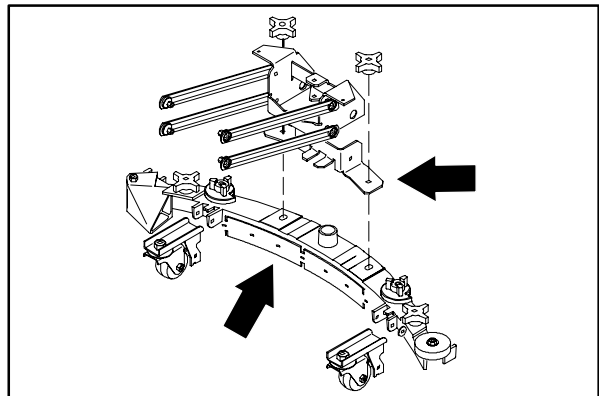

4. Tighten the mounting knobs.

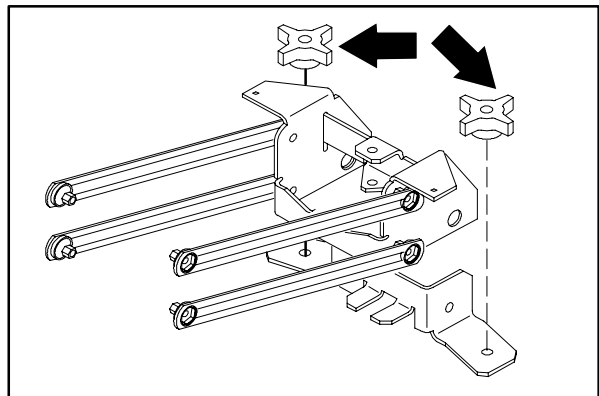

5. Push the squeegee suction hose onto the squeegee fitting.

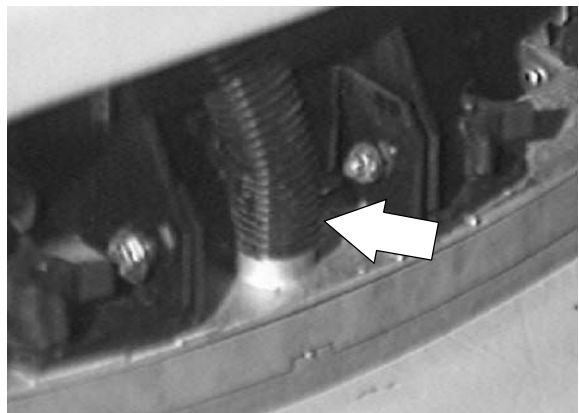

# T15 Maintenance & Repair

## TO LEVEL REAR SQUEEGEE

Leveling of the squeegee assures even contact for the length of the squeegee blade with the surface being scrubbed. Make sure this adjustment is done on an even, level floor.

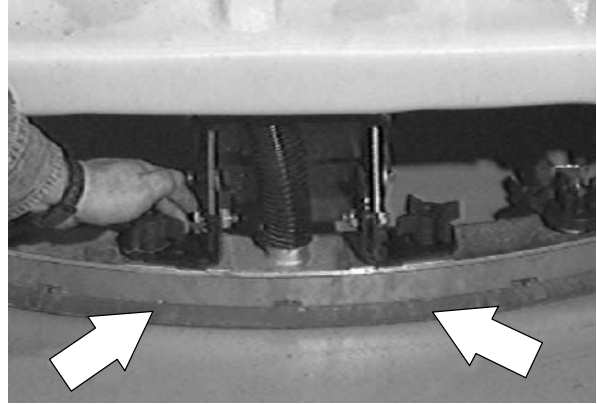

1. Turn the machine power on.

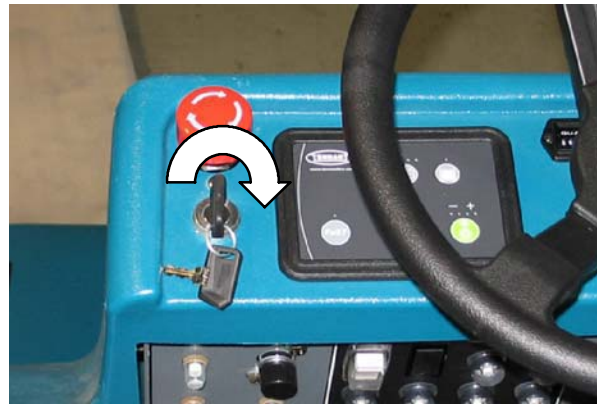

2. Lower the squeegee.



3. Drive the machine forward a few feet, then turn key switch OFF.

**FOR SAFETY: Before Leaving Or Servicing Machine; Stop On Level Surface, turn key switch OFF.**



# T15 Maintenance & Repair

4. Look at the deflection of the squeegee over the full length of the squeegee blade.

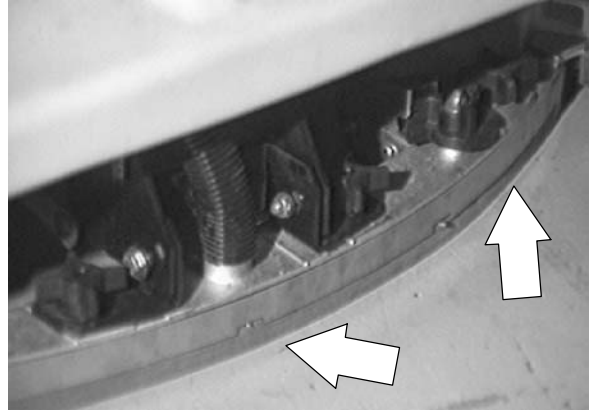

5. If the deflection is not the same over the full length of the blade, turn the squeegee leveling knob to make adjustments.

The squeegee leveling knob is located directly behind the squeegee suction hose. **DO NOT** disconnect the suction hose from the squeegee frame when leveling squeegee.

-Turn the squeegee leveling knob **counter-clockwise to increase** the deflection at the ends of the squeegee.

-Turn the squeegee leveling knob **clockwise to decrease the deflection** at the ends of the squeegee blade.

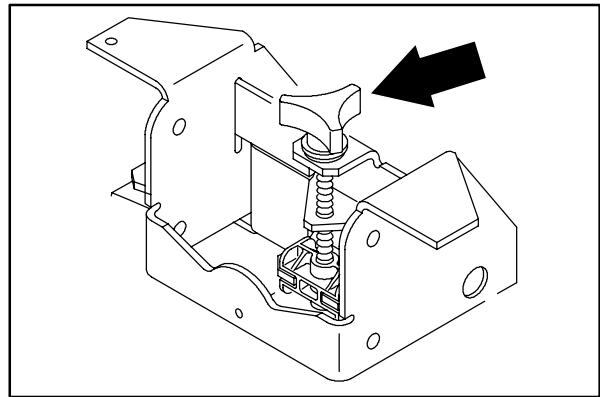

6. Drive the machine forward with the squeegee down to check the squeegee blade deflection.

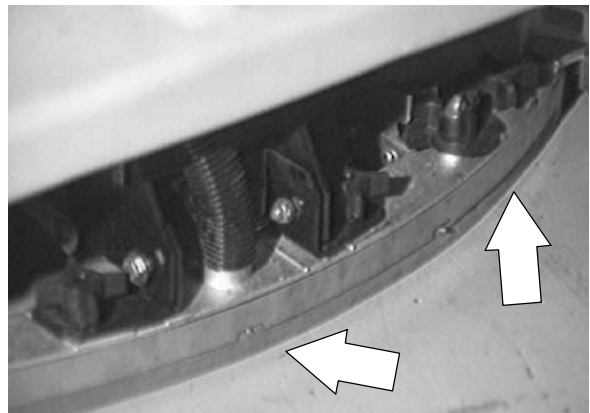

7. Readjust the squeegee blade deflection if necessary.



# T15 Maintenance & Repair

## TO ADJUST REAR SQUEEGEE BLADE DEFLECTION

Deflection is the amount of curl the squeegee blade has when the machine moves forward while the squeegee lowered to the floor. The best deflection is when the squeegee wipes the floor just dry with a minimum amount of deflection.

1. Turn the machine power on.

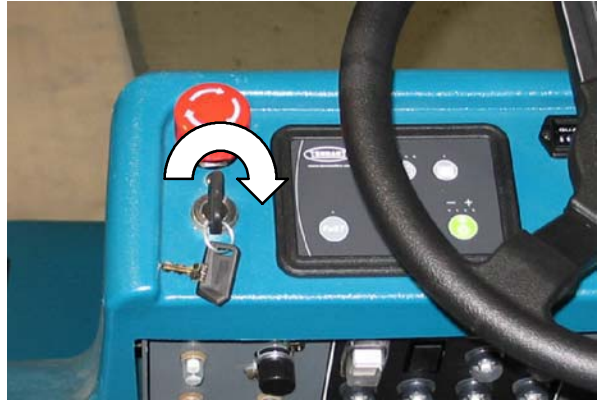

2. Lower the squeegee.



3. Drive the machine forward, and look at the deflection of the squeegee blade. The correct amount of deflection is 12 mm (0.50 in) for scrubbing smooth floors and 15 mm (0.62 in) for rough floors.

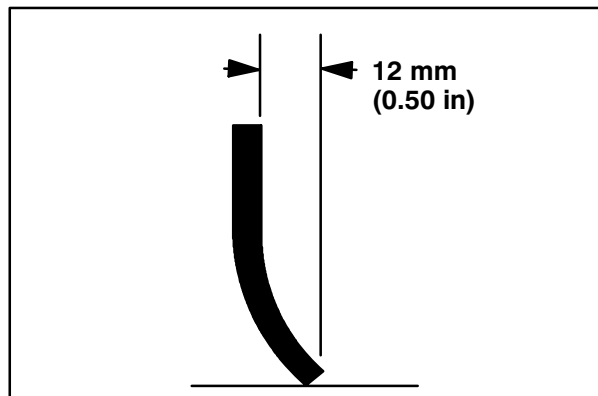

03719

# T15 Maintenance & Repair

4. Turn the machine power off.

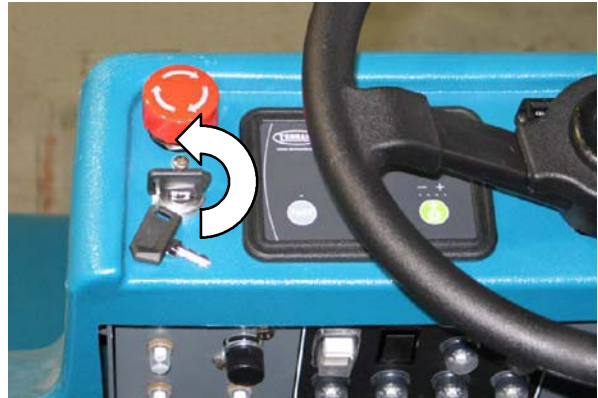

5. To adjust the amount of deflection, turn the squeegee deflection cams clockwise to decrease the blade deflection.

*NOTE: Turn the squeegee deflection cams counter-clockwise to increase blade deflection.*

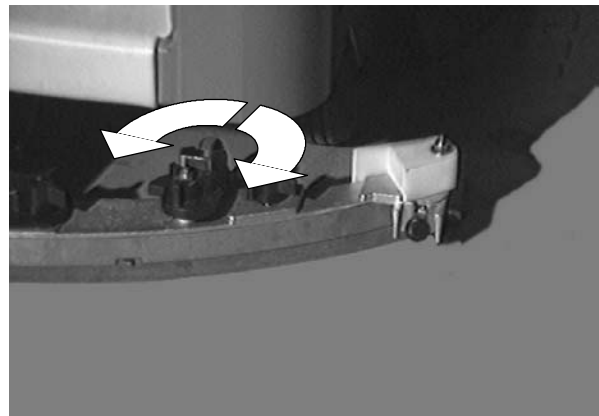

6. Drive the machine forward again to check the squeegee blade deflection.

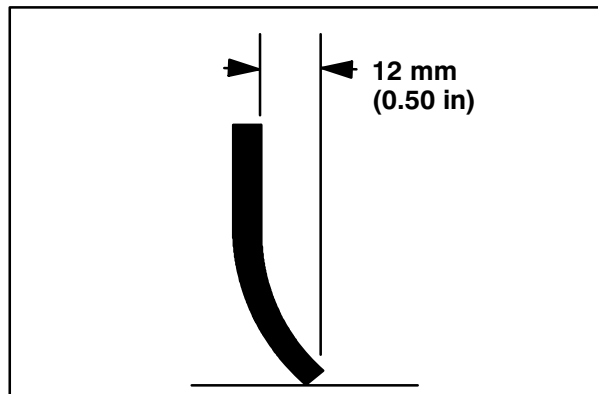

7. Readjust the squeegee blade deflection if necessary.

03719



# T15 Maintenance & Repair

## REAR SQUEEGEE CASTERS

The rear squeegee casters each have two grease fittings. Lubricate the pivot point and caster bearing on each squeegee caster with Lubriplate EMB grease (TENNANT part no. 01433-1) every 50 hours.

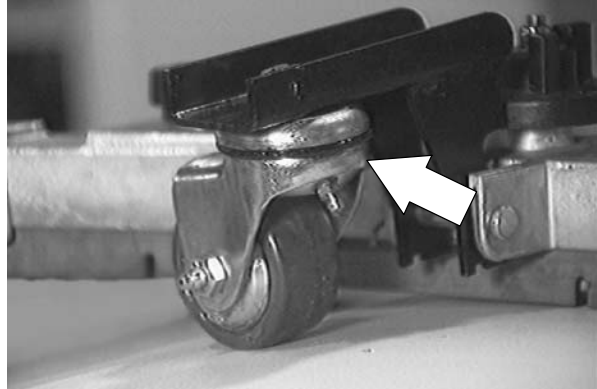

## TO ADJUST REAR SQUEEGEE GUIDE ROLLER

On the left end of the squeegee is a guide roller that guides the squeegee blade end along a wall. Loosen the nut at the top of the guide roller and move the roller in or out to adjust how close the end of the squeegee blade is to the wall. The squeegee blade end should be further away from the wall when the floor curves up into the wall.

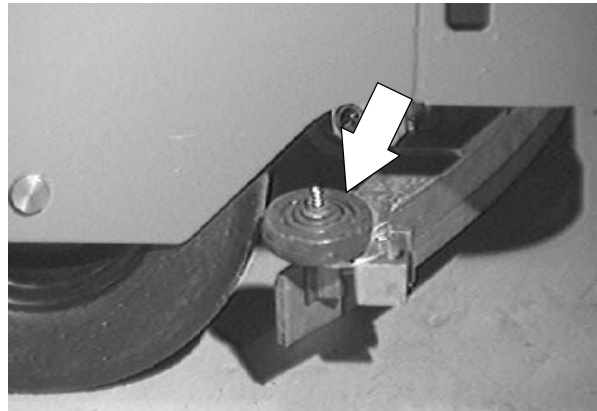



# T15 Maintenance & Repair

---

## REAR SQUEEGEE BLADES

---

The rear squeegee has two squeegee blades, the front and rear. Each blade has four wiping edges. To use them all, start with one wiping edge. To use the next wiping edge, rotate the blade end-for-end. To use the next wiping edge, rotate the top edges down, bottom edges up. To use the last edge, rotate the blade end-for-end. Rotate squeegee blades when they become worn half-way through the thickness of the blade.

Replace damaged squeegee blades.

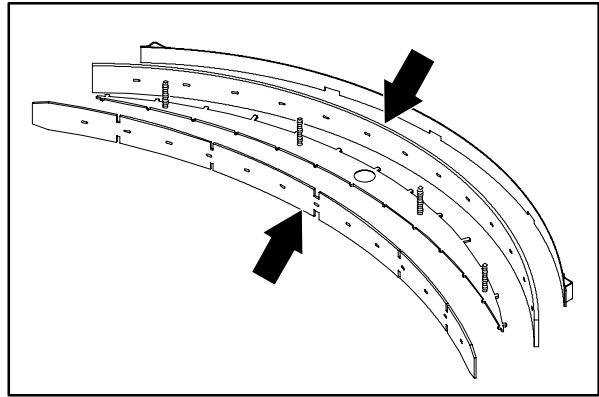

## TO REPLACE OR ROTATE REAR SQUEEGEE (REAR) BLADE

1. Make sure the squeegee is raised off the floor.



2. Turn the machine power off.

**FOR SAFETY: Before Leaving Or Servicing Machine; Stop On Level Surface, turn key switch OFF.**

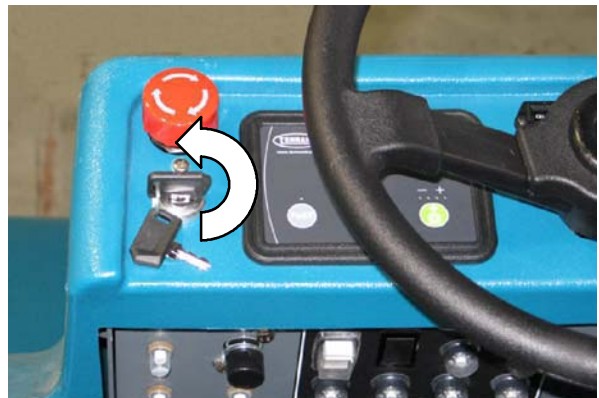

# T15 Maintenance & Repair

3. Loosen the two retainer knobs, one at each end of the squeegee.

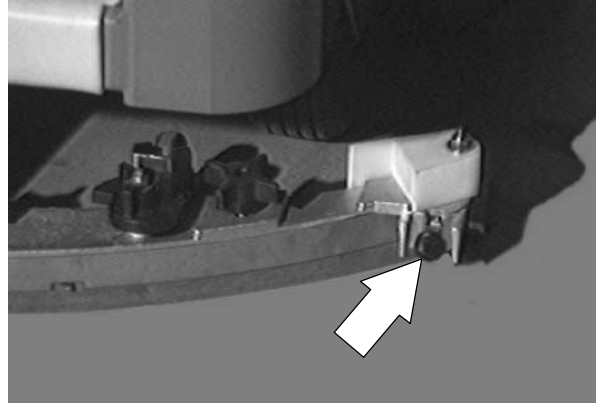

4. Pull off the rear retaining band.

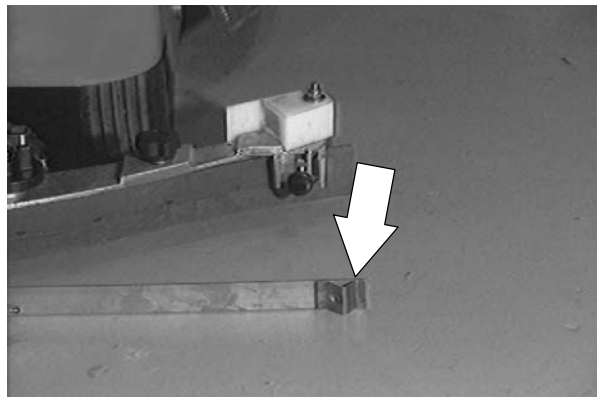

5. Pull off the rear squeegee blade.

6. Insert the rotated or new squeegee blade and then insert the retainer band.

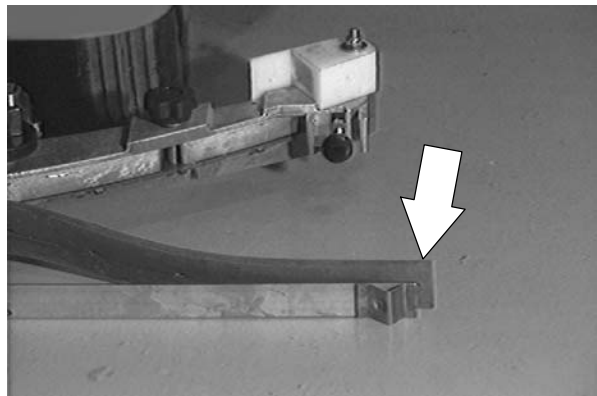

7. Tighten the two retainer knobs until the ends of the front and rear squeegee blades touch. Do not over-tighten.

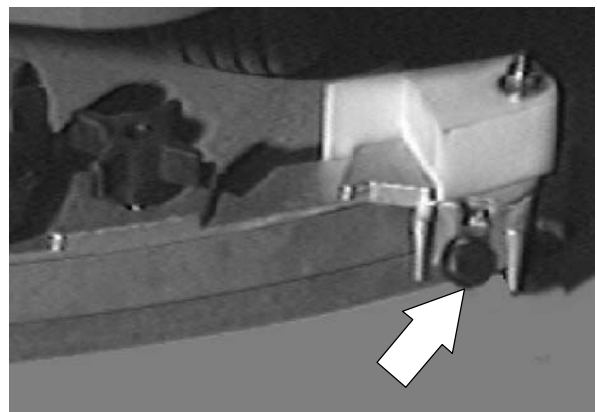

M

# T15 Maintenance & Repair

## TO REPLACE OR ROTATE REAR SQUEEGEE (FRONT) BLADE

1. Make sure the squeegee is raised off the floor.



2. Turn the machine power off.

**FOR SAFETY: Before Leaving Or Servicing Machine; Stop On Level Surface, turn key switch OFF.**

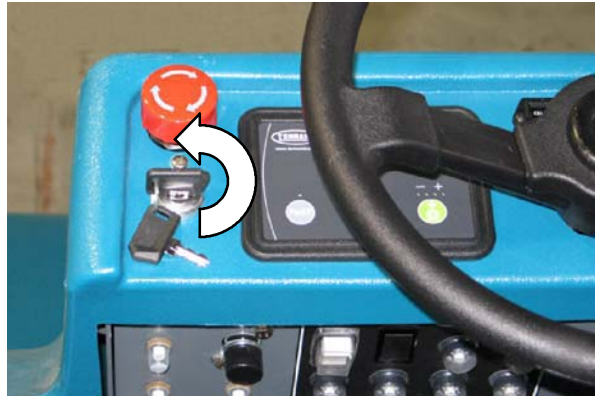

3. Remove the squeegee from the machine. See TO REMOVE SQUEEGEE ASSEMBLY instructions.

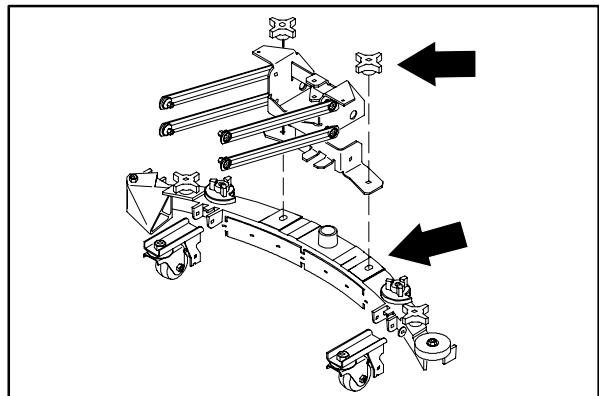

4. Remove the rear squeegee blade and retainer. See TO REPLACE OR ROTATE REAR SQUEEGEE (REAR) BLADE.

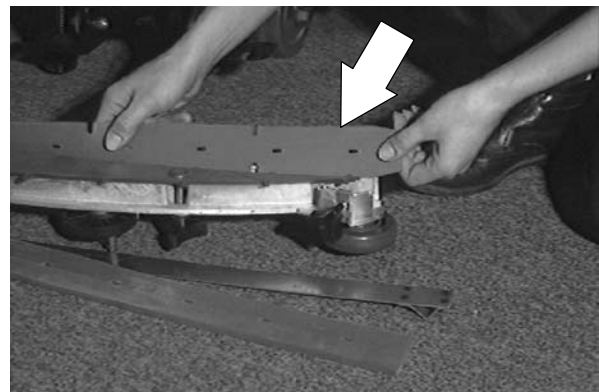

# T15 Maintenance & Repair

5. Loosen the two remaining knobs on top of the squeegee assembly.

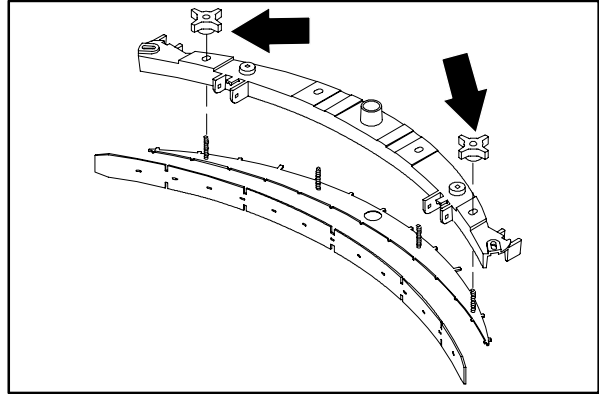

6. Pull the retainer plate back and pull out the front squeegee blade of the squeegee frame.

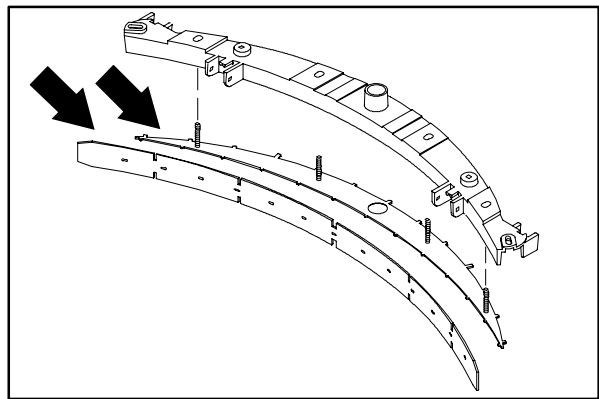

7. Insert the rotated or new squeegee blade in the squeegee frame, lining up the slots in the blade with the tabs on the retainer plate.

8. Push the retainer plate forward. Tighten the two outside knobs on top of the squeegee assembly.

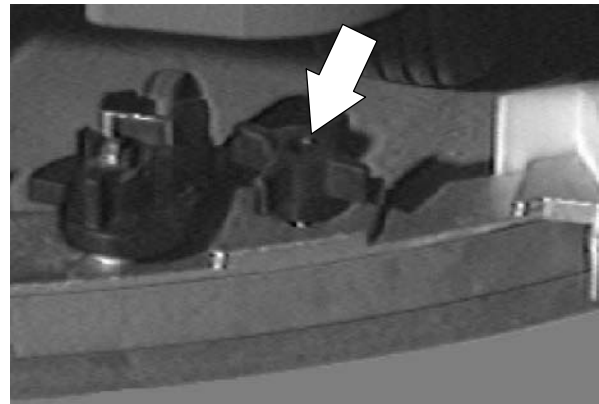

9. Insert the rear squeegee blade and retainer. Tighten the two rear blade retainer knobs until the ends of the front and rear squeegee blades touch. Do not over-tighten.



# T15 Maintenance & Repair

10. Install the squeegee assembly on the squeegee pivot. See TO INSTALL SQUEEGEE ASSEMBLY instructions.

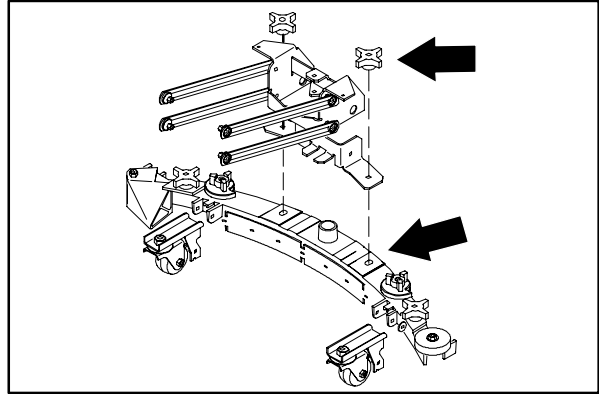

11. Adjust the squeegee blade leveling and deflection as stated in TO LEVEL SQUEEGEE and ADJUST SQUEEGEE BLADE DEFLECTION instructions.

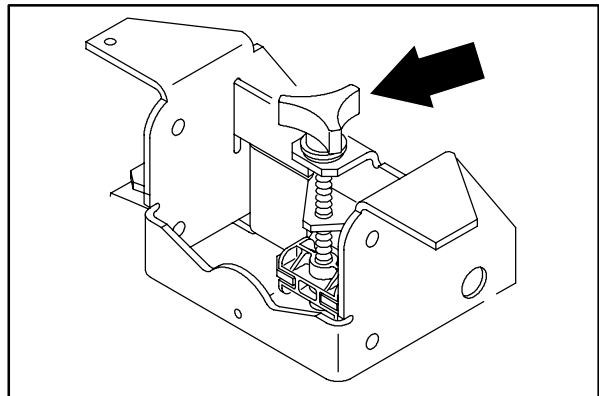

# T15 Maintenance & Repair

## REAR SQUEEGEE WHEEL CAMS

The squeegee wheel cams adjust the squeegee deflection along the entire length of the squeegee. There is a wheel cam at either end of the squeegee.

**Increase deflection:** Turn the cams counter-clockwise.

**Decrease deflection:** Turn the cams clockwise.

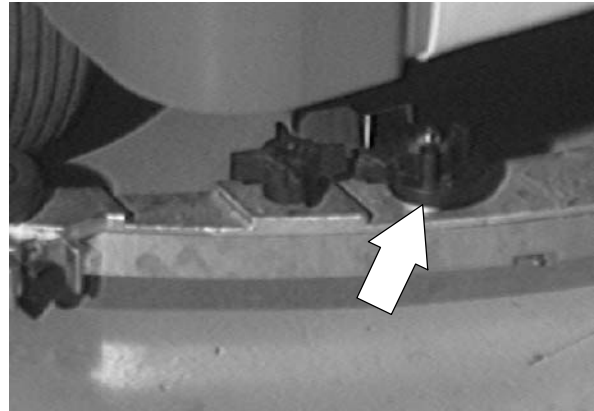

## REAR SQUEEGEE LEVELING KNOB

The squeegee leveling knob adjusts the deflection at the ends of the squeegee.

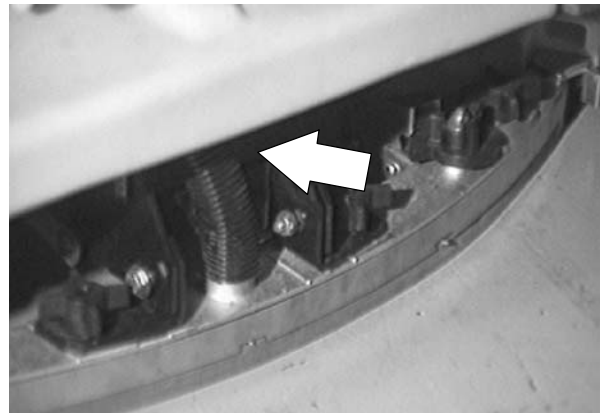

The squeegee leveling knob is located directly behind the squeegee suction hose.

**NOTE: DO NOT** disconnect the suction hose from the squeegee frame when leveling squeegee.

**Increase end deflection:** Turn the squeegee leveling knob counter-clockwise to increase the deflection at the end of the squeegees.

**Decrease end deflection:** Turn the squeegee leveling knob clockwise to decrease the deflection at the end of the squeegees.

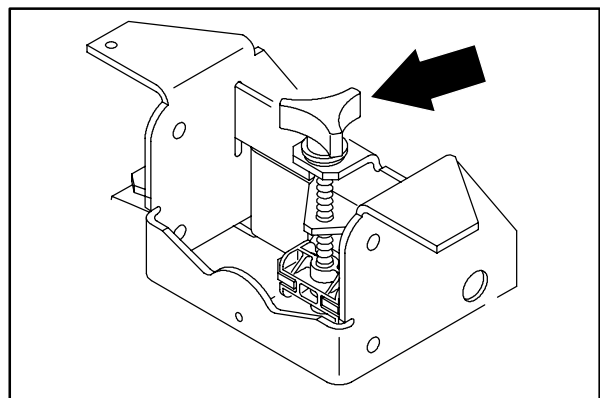

# T15 Maintenance & Repair

## TO REPLACE REAR SQUEEGEE LIFT CABLE

1. Lower the squeegee to the floor.



2. Make sure the solution tank is drained and the tank clean out caps removed.

**FOR SAFETY: Before Leaving Or Servicing Machine; Stop On Level Surface, turn key switch OFF.**

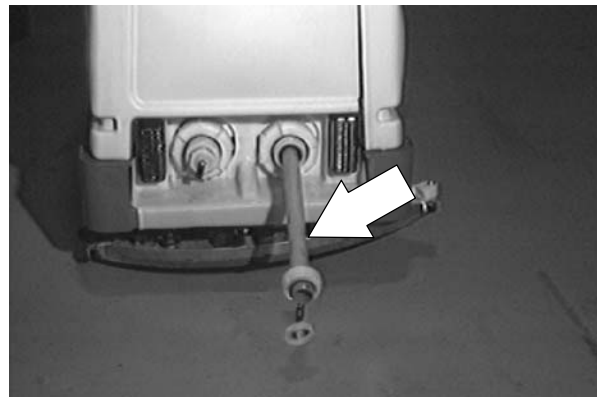

3. Remove the four hex screws holding the plastic, rear drain splash tray. Let it drop down for access to the rear squeegee lift cable.

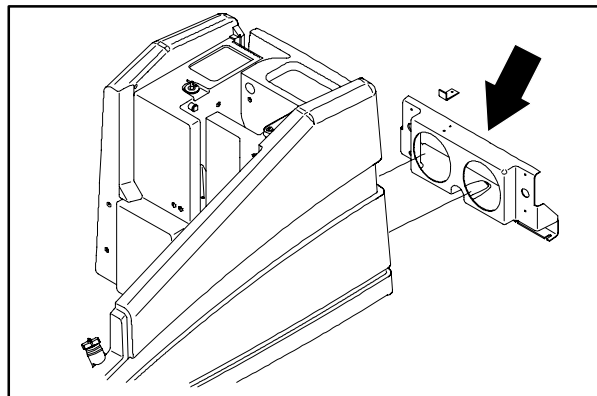

4. Locate the rear squeegee lift cable. Remove the cotter pin and clevis pin from the end of the lift cable where it attaches to the lift pivot bracket.

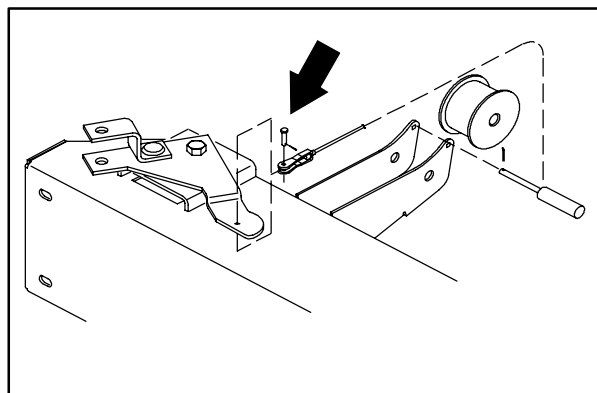

# T15 Maintenance & Repair

5. Remove the cotter pin and long clevis pin from just behind the lift cable drum.

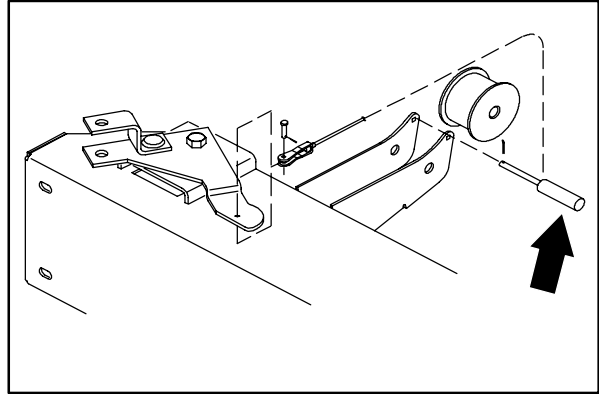

6. Remove the cotter pin and clevis pin from the end of the lift cable where it attaches to the squeegee frame. Remove the cable from the machine.

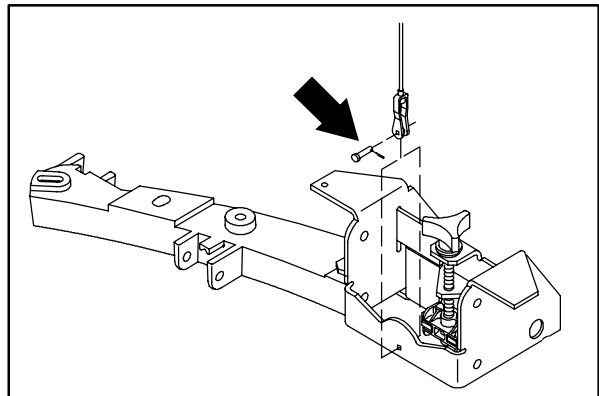

7. Position the new cable in the machine. Start by attaching one end of the cable to squeegee frame. Reinstall the clevis pin and cotter pin.

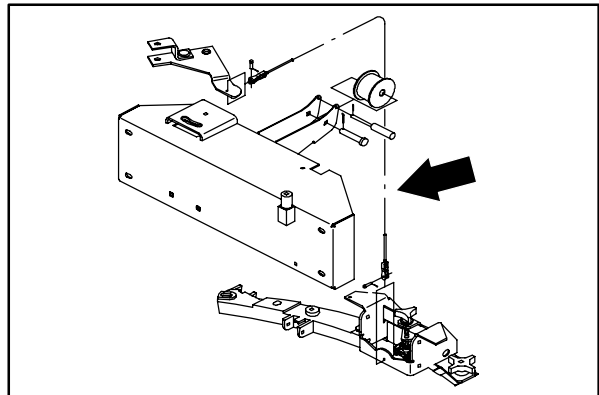

8. Attach the other end of the new lift cable to the lift pivot bracket. Reinstall the clevis pin and cotter pin.

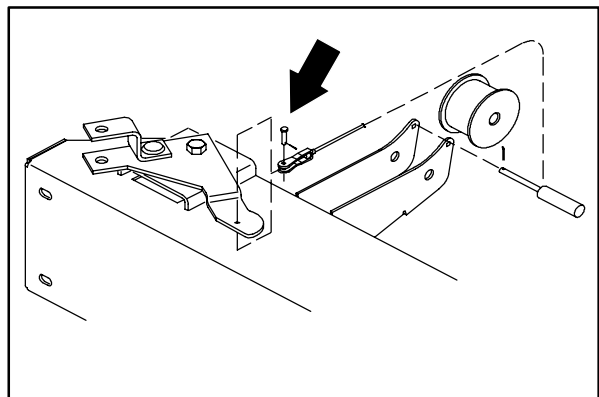



# T15 Maintenance & Repair

9. Reinstall the long clevis pin and cotter pin in the mount hole just behind the lift cable drum.

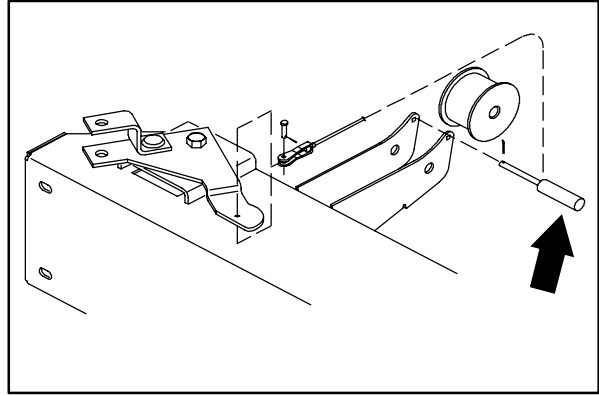

10. Reinstall the plastic, rear drain splash tray. Hand tighten the mounting hardware.

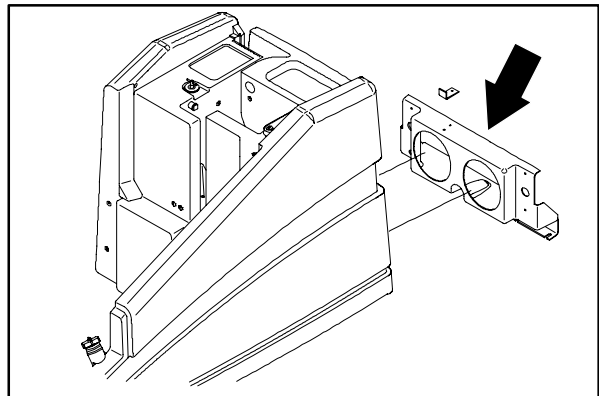

11. Reinstall the tank caps.

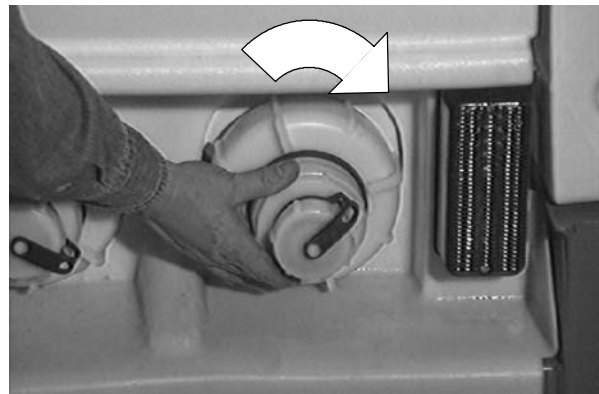

12. Start the machine and raise the rear squeegee. Check the new cable for proper operation.



# T15 Maintenance & Repair

## SIDE SQUEEGEE BLADES

The side squeegees control water spray and channel water into the path of the rear squeegee. Check the side squeegees for damage and wear daily.

Replace the side squeegee blades if they become damaged or lose their shape. Replace the squeegee deflectors if they become worn.

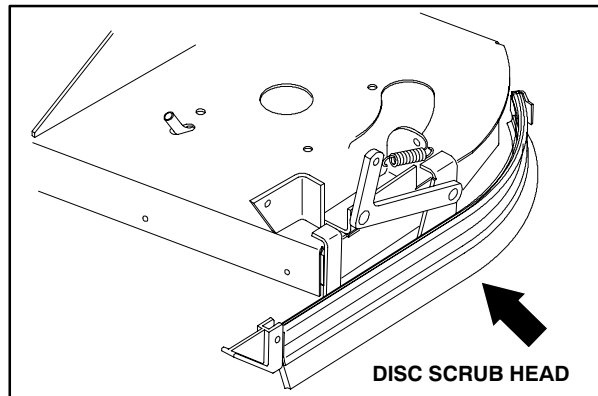
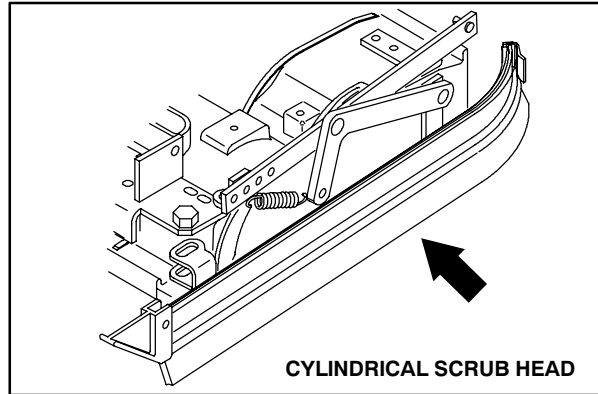

# T15 Maintenance & Repair

## TO REPLACE SIDE SQUEEGEE BLADES

1. Raise the scrub head.



2. Turn the machine power off.

**FOR SAFETY: Before Leaving Or Servicing Machine; Stop On Level Surface, turn key switch OFF.**

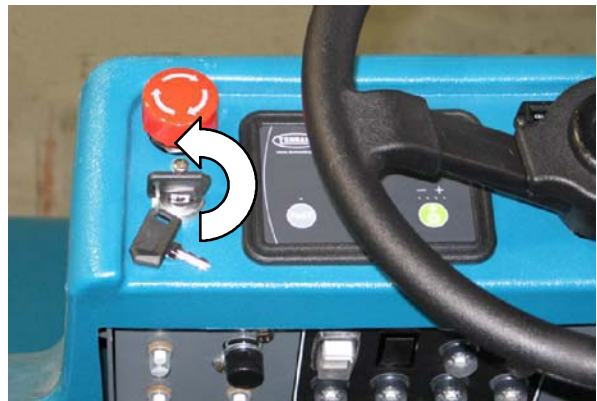

3. Remove the cotter pin, clevis pin, deflector and the retainer bracket from the side squeegee.

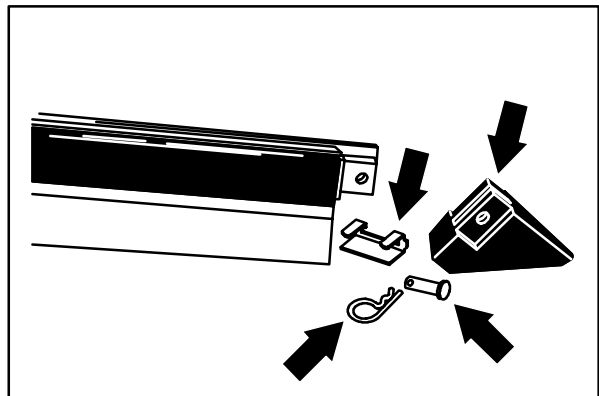

4. Pull the squeegee out of the squeegee frame.
5. Slide a new squeegee blade into the frame.
6. Replace the retainer bracket, deflector, clevis pin, and cotter pin.
7. Repeat for the side squeegee on the other side of the scrub head.

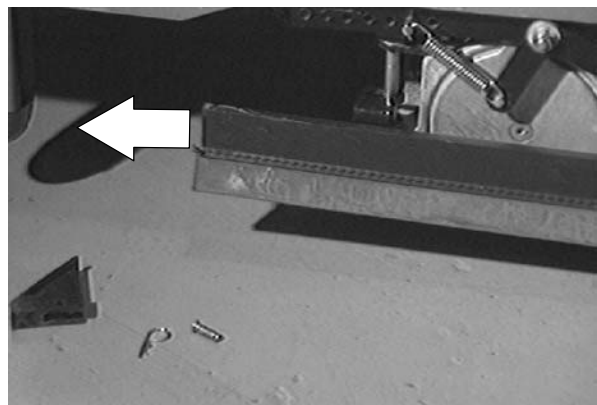

# T15 Maintenance & Repair

---

## SQUEEGEE LIFT ACTUATOR

---

The lift actuator is an electric device that, with a push of a switch, raises and lowers the rear squeegee.

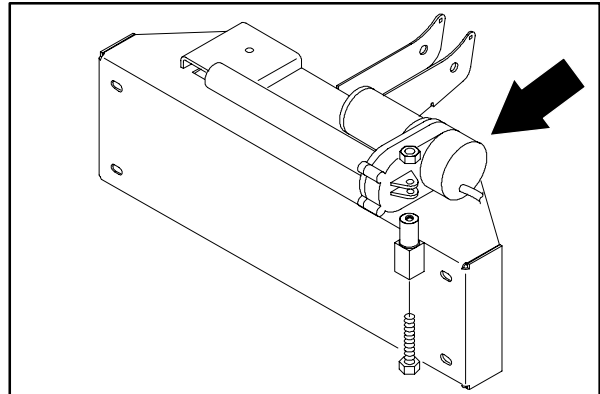

# T15 Maintenance & Repair

## TO REPLACE REAR SQUEEGEE LIFT ACTUATOR

1. Start the machine and lower the rear squeegee. Shut off the machine.

**FOR SAFETY: Before Leaving Or Servicing Machine; Stop On Level Surface, turn key switch OFF.**



2. Disconnect the squeegee lift actuator from the main electrical harness.

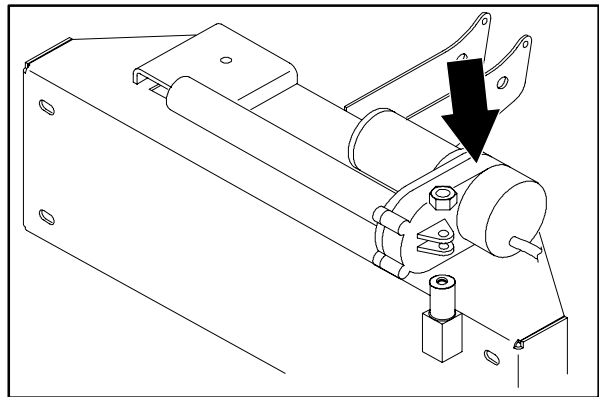

3. Locate the four screws holding the squeegee mount channel to the back of the machine.

4. Remove the four screws. Let the squeegee mount channel and squeegee assembly drop down to access the lift actuator.

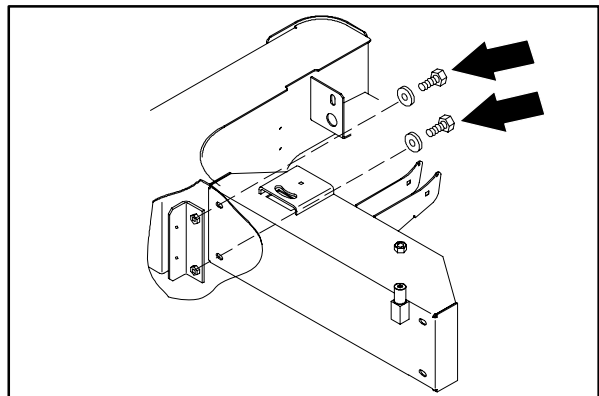

5. Remove the long hex screw and nyloc nut from the motor end of the lift actuator.

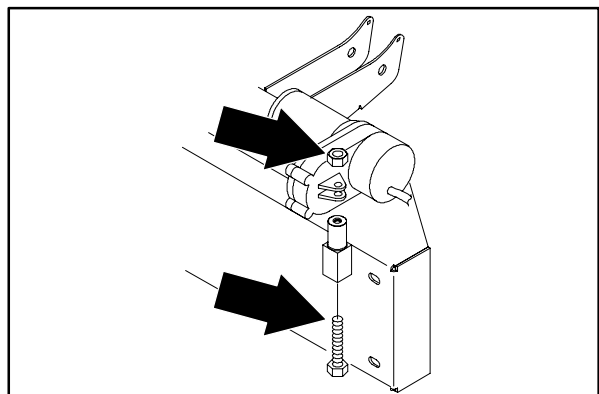

# T15 Maintenance & Repair

6. Remove the cotter pin and clevis from the tube end of the lift actuator.

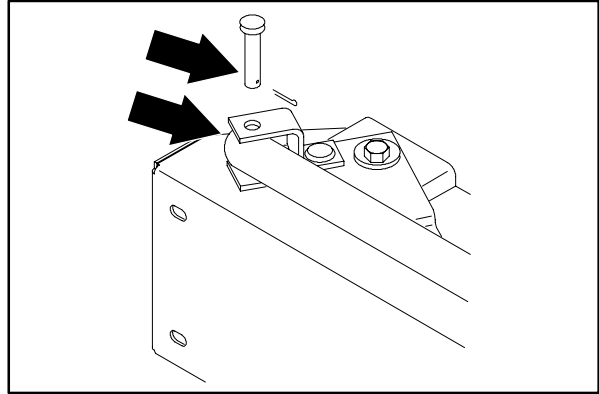

7. Remove the actuator from the machine.

8. Position the new actuator on the squeegee weldment and the tube end into the pivot weldment.

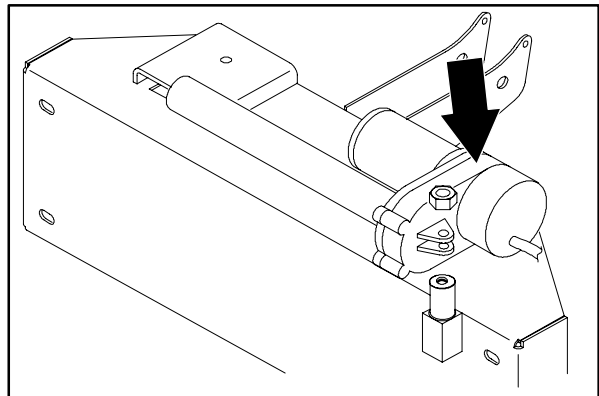

9. Reinstall the hex screw and nut in the motor end of the lift actuator.

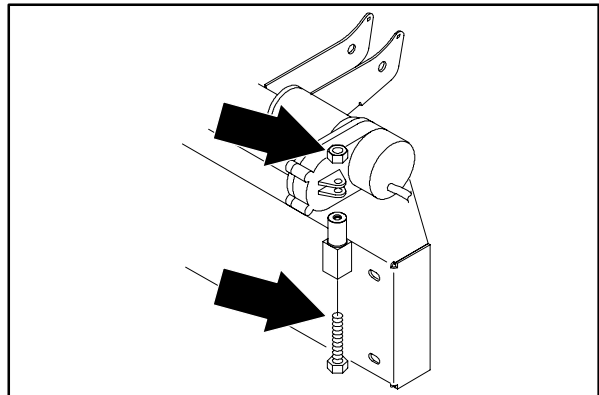

10. Reinstall the cotter pin and clevis in the tube end of the lift actuator.

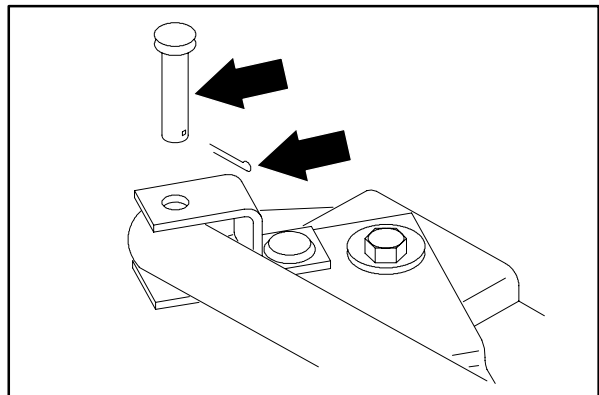

## T15 Maintenance & Repair

11. Position the squeegee mount channel and squeegee assembly back into position on the back of the machine frame. Reinstall the four screws. Tighten to 37 - 48 Nm (26 - 34 ft lb).
12. Reconnect the squeegee lift actuator to the main electrical harness. See schematic in this section.
13. Start the machine and check the rear squeegee actuator for proper operation.

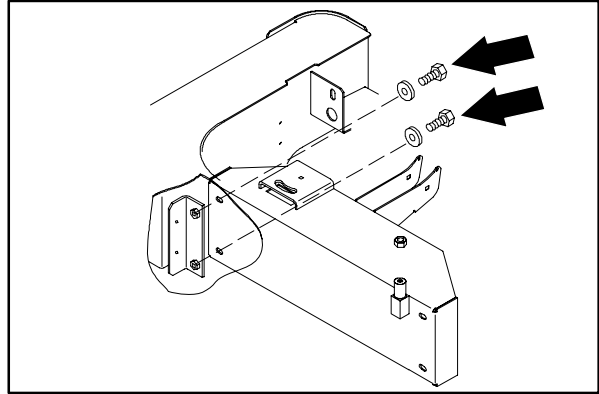

# T15 Maintenance & Repair

---

## VACUUM FAN

---

The vacuum fan, when activated, creates air flow in the recovery tank. With the recovery tank cover closed, the air flow from the vacuum fan creates vacuum at the squeegee vacuum hose. This vacuum pulls water from the lowered squeegee into the recovery tank. The vacuum fan is equipped with a easily serviceable air filter.

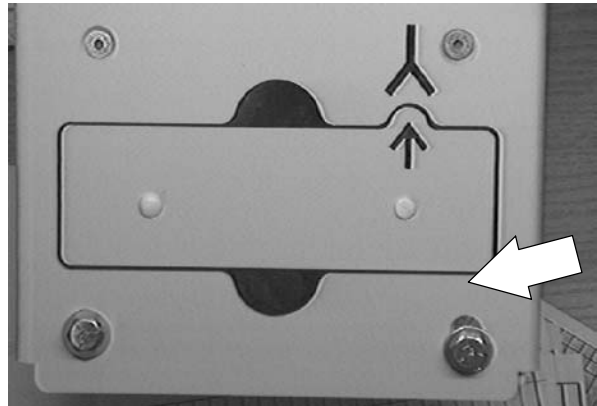

### TO REMOVE VACUUM FAN ASSEMBLY

**FOR SAFETY: Before Leaving Or Servicing Machine; Stop On Level Surface, turn key switch OFF.**

1. Open the recovery/solution tank cover.

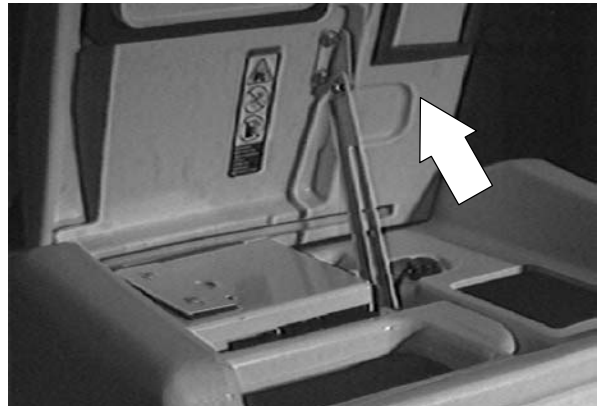

2. Locate the vacuum fan on the left, front of the recovery tank.

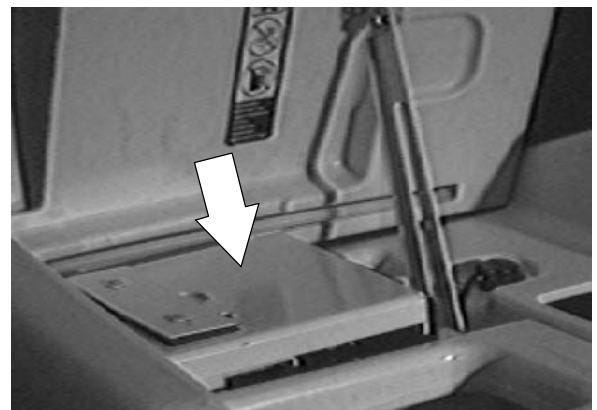



# T15 Maintenance & Repair

3. Remove the two screws holding the vacuum fan to the top of the tank. Pull the vacuum fan assembly out of the top of the tank. Let it rest on the edge of the tank.

4. Disconnect the vacuum fan motor from the main electrical harness.

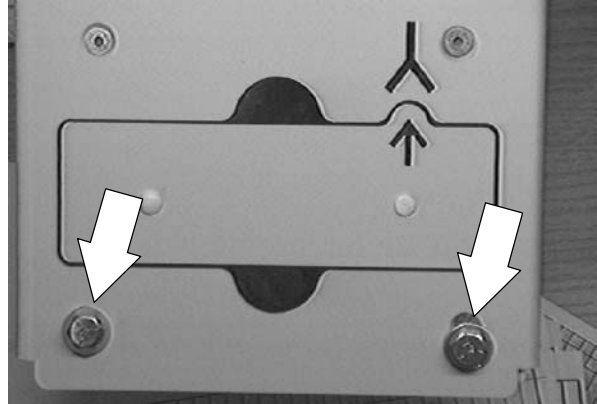

5. Remove the vacuum fan assembly from the machine. Be careful not to lose the rubber seal on the outlet of the vacuum housing.

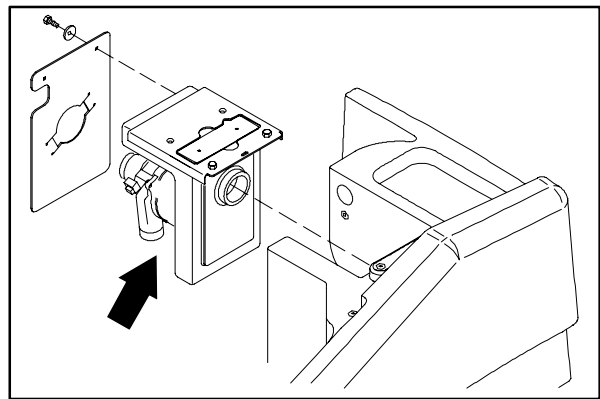

# T15 Maintenance & Repair

## TO INSTALL VACUUM FAN ASSEMBLY

**FOR SAFETY: Before Leaving Or Servicing Machine; Stop On Level Surface, turn key switch OFF.**

1. Open the recovery/solution tank cover.



2. Position the vacuum fan assembly on the edge of the recovery tank.
3. Connect the plug from the vacuum fan motor to the main electrical harness. See schematic in the ELECTRICAL section.

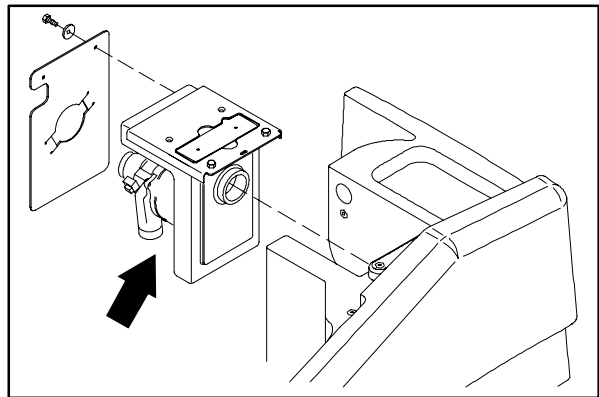

4. Drop the vacuum fan assembly straight down into the tank mounting area. Make sure the rubber seal is in place on the outlet of the vacuum housing.

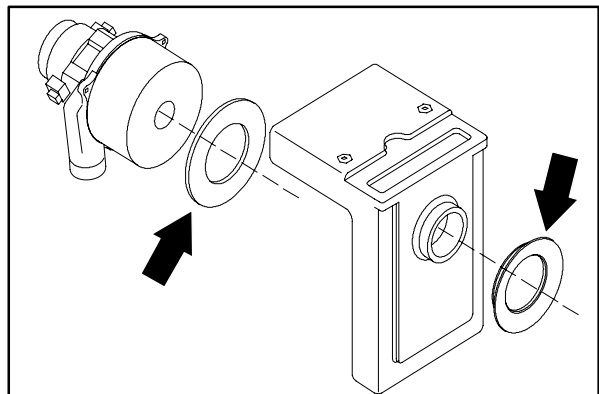

M

## T15 Maintenance & Repair

5. Install the two screws and tighten to 18 - 24 Nm (15 - 20 ft lb).

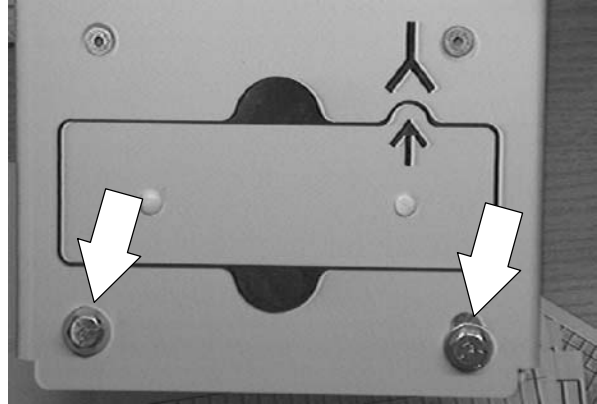

6. Close the tank cover and operate the machine. Check the vacuum fan for proper operation.

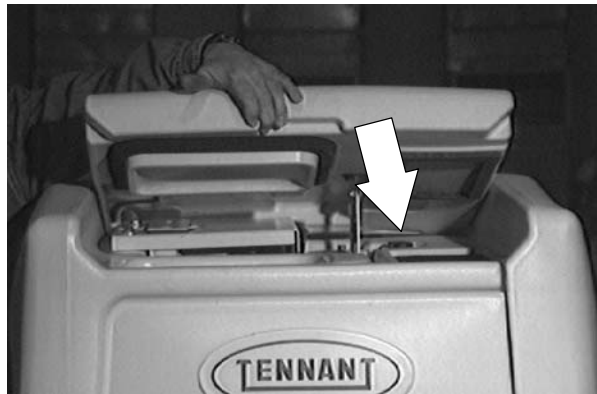

# T15 Maintenance & Repair

## TO REPLACE VACUUM FAN

**FOR SAFETY: Before Leaving Or Servicing Machine; Stop On Level Surface, turn key switch OFF.**

1. Remove the vacuum fan assembly from the machine. See TO REMOVE VACUUM FAN ASSEMBLY instructions in the SCRUBBING section.

*NOTE: Make sure to note the position of the vacuum fan exhaust outlet when removing the fan from the housing.*

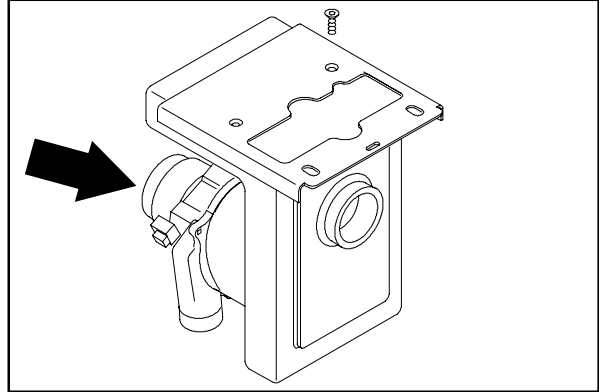

2. Remove the three screws and brackets holding the vacuum fan to the plastic housing. Remove the vacuum fan.

*NOTE: Make sure to install a gasket on the bottom of the new fan.*

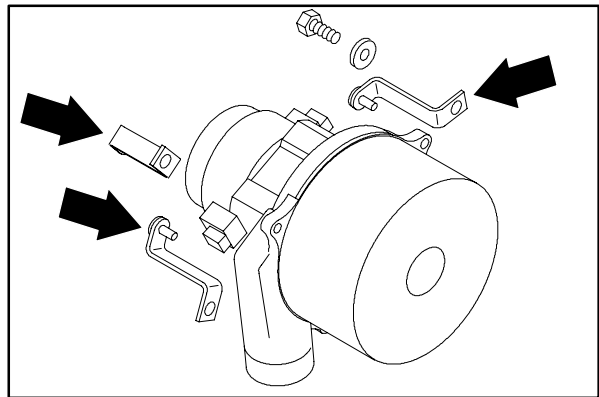

3. Position the new fan on the housing in the same orientation as the old fan.

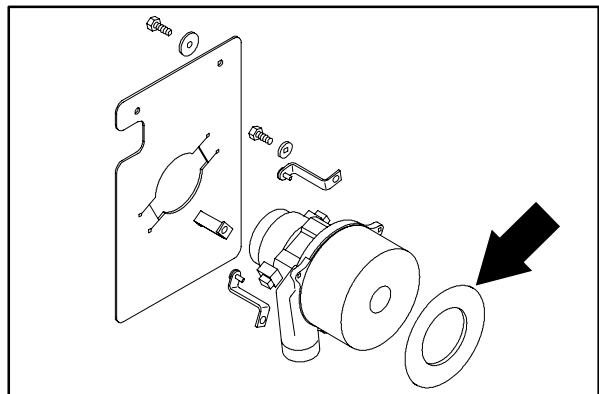

# T15 Maintenance & Repair

4. Reinstall the three screws and brackets.  
Tighten the hardware only until the gasket starts to compress.

*NOTE: On a machine equipped with the HD vacuum fan option, there is two fans and three added brackets and screws.*

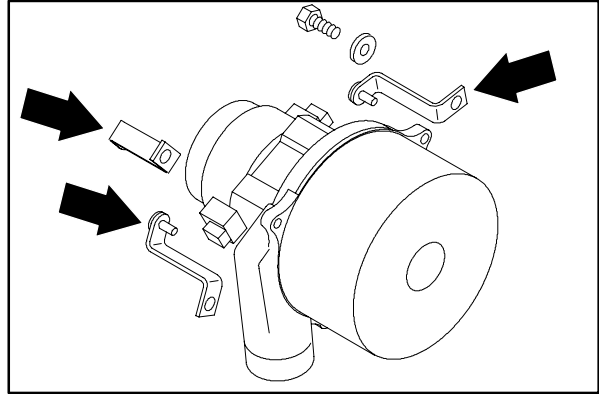

5. Reinstall the vacuum fan assembly in the machine. See TO INSTALL VACUUM FAN ASSEMBLY instructions in the SCRUBBING section.

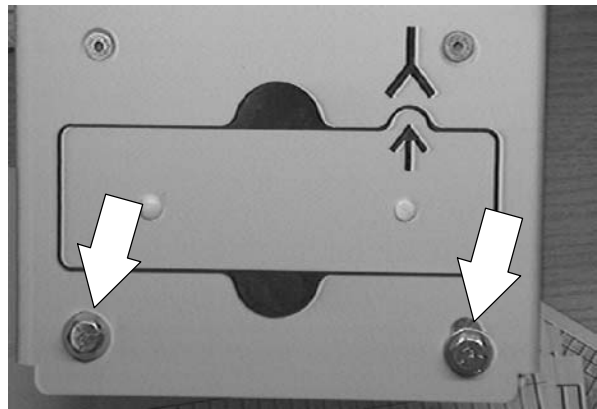

# T15 Maintenance & Repair

---

## PRE-SWEEP BRUSHES

---

The Pre-Sweep assembly is equipped with *disk* and *cylindrical* brushes. Check the brushes daily for wire or string tangled around the brush or brush drive hub. Check the brushes daily for damage and wear.

The side brush (option) is a disk brush. Check the brush daily for wire or string tangled around the brush or brush drive hub. Check the brush daily for damage and wear.

## PRE-SWEEP DISK BRUSHES

The disk brushes should be replaced if a large number of bristles are missing or if bristle length is less than 10 mm (0.38 in).

## REPLACING THE DISK BRUSHES

1. Turn the machine power on.
2. Press the bottom of the Pre-Sweep switch to raise the Pre-Sweep assembly and stop sweeping.
3. Turn the machine power off.

**FOR SAFETY: Before leaving or servicing machine, stop on level surface, turn off machine, and remove key.**



# T15 Maintenance & Repair

4. Pull the cotter pin from the end of the retaining pin. Remove the side brush retaining pin from the side brush drive shaft.

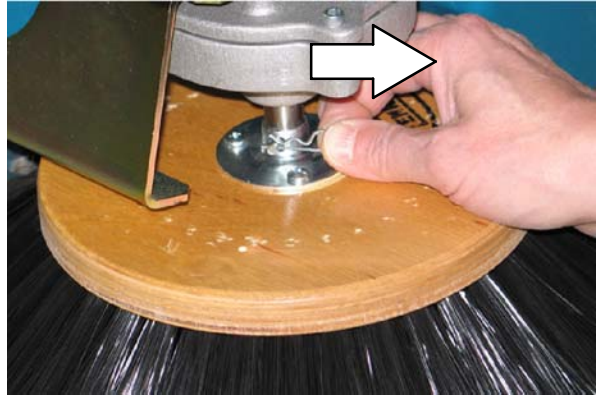

5. Remove the old side brush.



6. Slide the new side brush onto the side brush drive shaft.

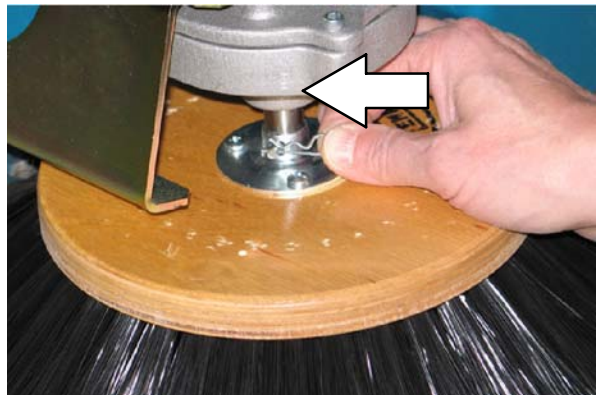

7. Insert the side brush retaining pin through the side brush hub and shaft. Replace the cotter pin in the end of the retaining pin.



# T15 Maintenance & Repair

## PRE-SWEEP CYLINDRICAL BRUSH

Check the brush taper every 50 hours of machine operation for maximum brush life and best sweeping performance.

The cylindrical brush should be replaced if large amounts of bristles are missing, or if the remaining bristle length is less than 10 mm (0.38 in).

## CHECKING AND ADJUSTING CYLINDRICAL BRUSH PATTERN

- 
1. Apply chalk (or another material that will not easily blow away), to a smooth, level section of the floor.
  2. Drive the machine so the Pre-Sweep assembly is centered in the chalk.
  3. Block the front or rear wheels to prevent the machine from moving.
  4. Lower the Pre-Sweep assembly in the chalked area. Slowly press down on the directional pedal until the Pre-Sweep brush begins to sweep. Allow the machine to sweep in the same place for 15 to 20 seconds.

*NOTE: If chalk or other material is not available, allow the brush to spin on the floor for two minutes. A polish mark will remain on the floor.*

5. Raise the Pre-Sweep assembly and move the machine away from the chalked area. Turn the machine power off.



# T15 Maintenance & Repair

6. Observe the shape of the brush pattern. If the brush pattern has parallel sides, the brush does not need adjustment.

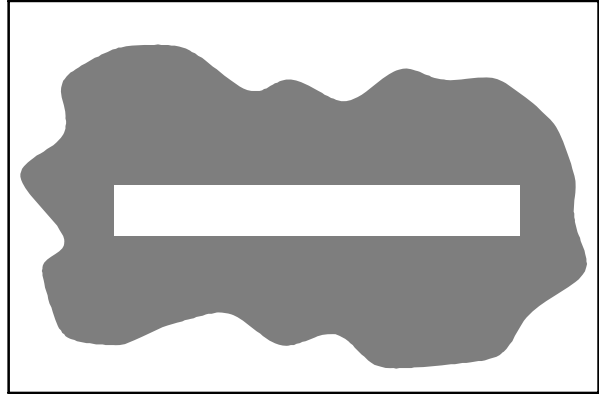

10355

If the brush pattern is tapered, the brush needs adjustment to straighten the brush pattern.

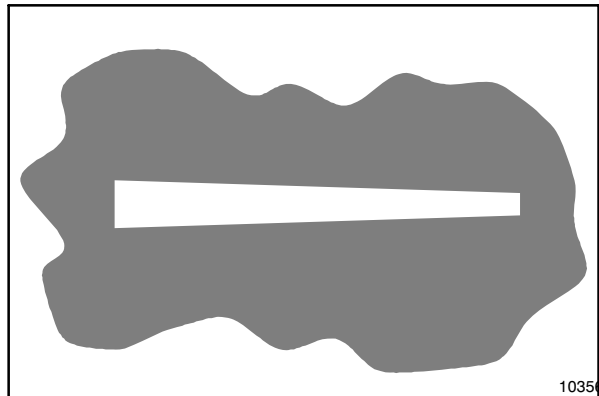

10356

- A. To adjust the brush taper, loosen the two lock nuts on the left hand brush arm.
- B. Turn the machine power on and lower the Pre-Sweep assembly. Allow the brush to float in place for 15 to 20 seconds.

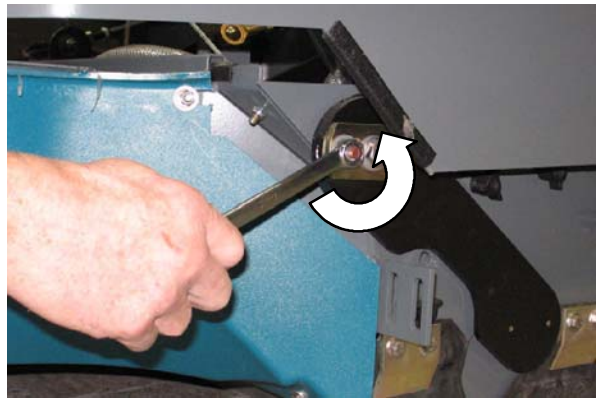

- C. Tighten the two lock nuts on the left hand brush arm.

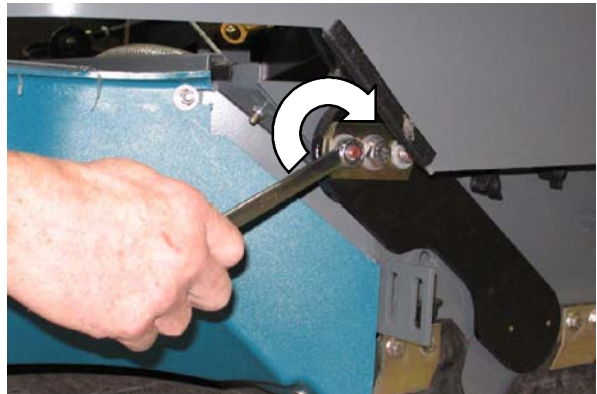

# T15 Maintenance & Repair

- D. Check the brush pattern again and readjust as necessary until the width of the pattern is the same along the length of the brush pattern.

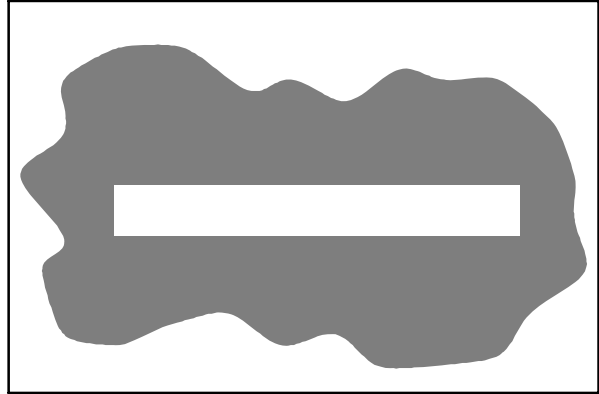

10355



## REPLACING THE PRE-SWEEP CYLINDRICAL BRUSH

1. Turn the machine power on.
2. Lower the Pre-Sweep assembly.
3. Turn the machine power off.

**FOR SAFETY: Before leaving or servicing machine, stop on level surface, turn off machine, and remove key.**



4. Loosen and remove the brush idler hex screw from the front of the idler plate.

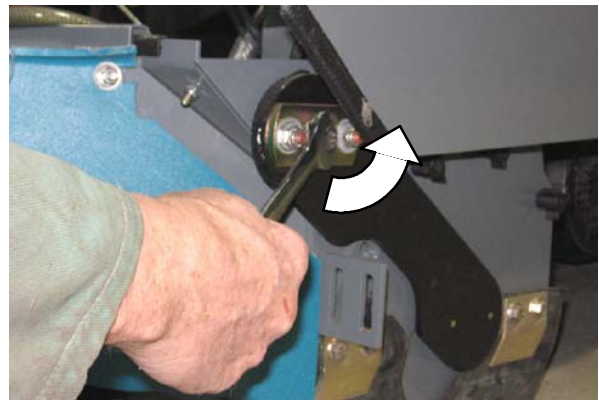

# T15 Maintenance & Repair

5. Loosen and remove the four brush housing door knobs. Set the brush housing idler plate aside.



6. Remove the cylindrical brush and replace with a new brush.

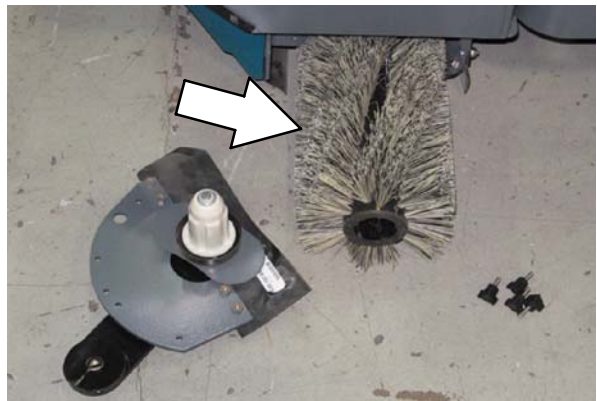

7. Guide the slotted end of the new brush onto the drive hub.

8. Replace the brush idler plate, and secure with the four brush housing door knobs and hex screw on the front of the idler plate.

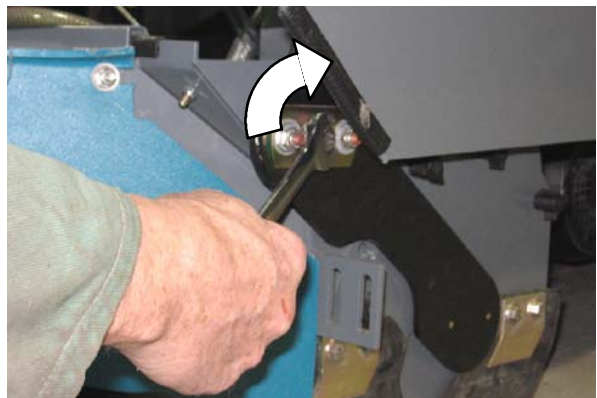

9. Check the new brush for proper adjustment. Readjust if necessary.



# T15 Maintenance & Repair

---

## SKIRTS AND SEALS

---

### PRE-SWEEP SIDE SKIRTS (OPTION)

The Pre-Sweep side skirts help direct debris into the debris hopper. The side skirts are located on both sides of the main sweeping brush in the Pre-Sweep assembly. The side skirts should be just touching the floor.

Check the skirts for damage and wear after every 50 hours of operation.

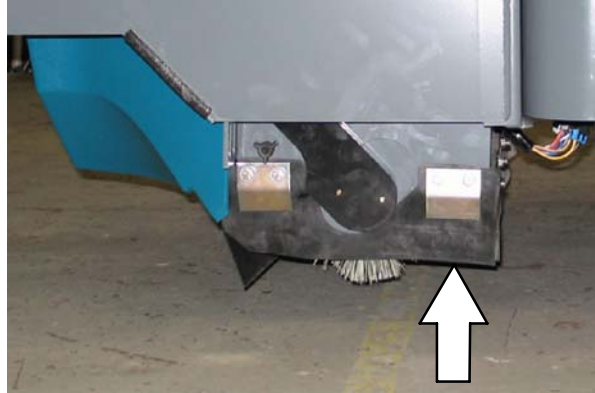

### PRE-SWEEP RECIRCULATION SKIRT (OPTION)

The Pre-Sweep recirculation skirt is located behind the main sweeping brush.

Check the skirt for damage and wear after every 50 hours of operation.



### PRE-SWEEP REAR SKIRT (OPTION)

The Pre-Sweep rear skirt is located behind the recirculation skirt and main sweeping brush.

Check the skirt for damage and wear after every 50 hours of operation.

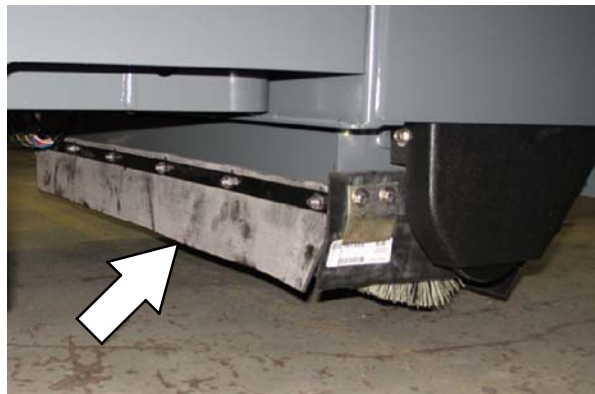

# T15 Maintenance & Repair

## PRE-SWEEP BRUSH DRIVE BELT (OPTION)

The Pre-Sweep brush drive belt is located inside the Pre-Sweep assembly on the right side of the cylindrical brush. The belt drives the cylindrical brush. Proper belt tension is a 2 mm (.08 in) deflection from a force of 0.76 to 0.8 kg (1.7 to 1.8 lb) at the belt midpoint.

Check the belt tension and wear every 100 hours of operation.

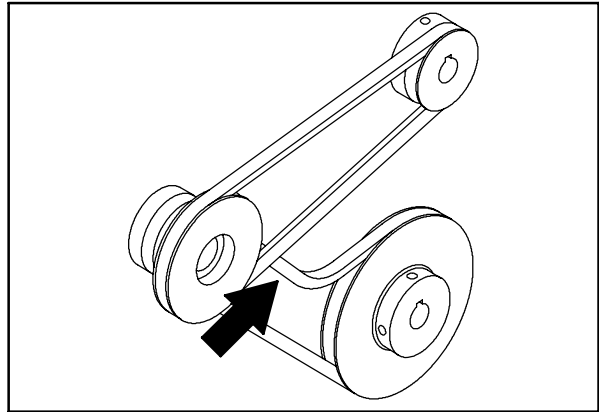
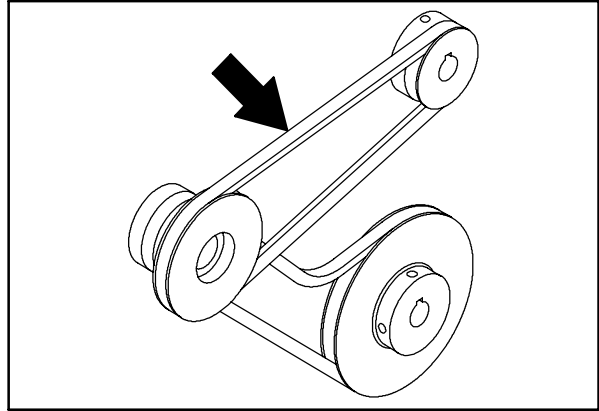

# T15 Maintenance & Repair

## STATIC DRAG STRAP

The static drag strap prevents the buildup of static electricity in the machine. The strap is attached to the rear squeegee mounting channel.

Make sure the strap is always touching the floor.

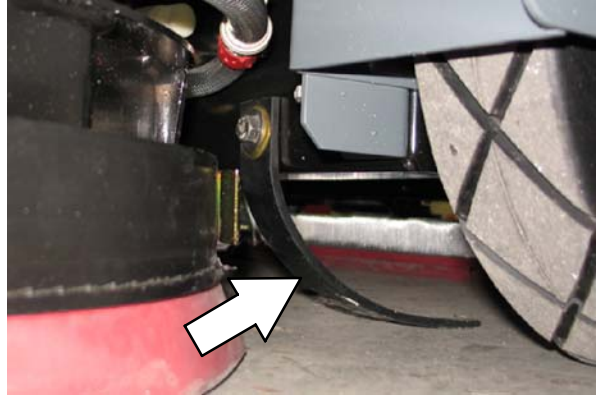

## STEERING GEAR CHAIN

The steering gear chain is located directly above the front tire.

The steering gear chain tension should be checked after the first 50 hours of operation and every 500 hours thereafter. The proper deflection should be 3 to 6 mm (0.1 to 0.3 in) between the steering sprocket and the idler sprocket when the steering wheel is turned as far as it will go in either direction.

---

## TIRES

---

The machine has three tires: one in front, and two in the rear of the machine. Torque the rear wheel nuts twice to 70 to 84 Nm (50 to 60 ft. lbs.) after the first 50 hours of operation, and every 1000 hours of operation. The tires are solid rubber. No maintenance is required.



# T15 Maintenance & Repair

## REAR TIRES AND WHEELS

The rear tires on the model T15 are semi-pneumatic. The rear tire and wheel assemblies are idler wheels only, they have no braking capabilities.

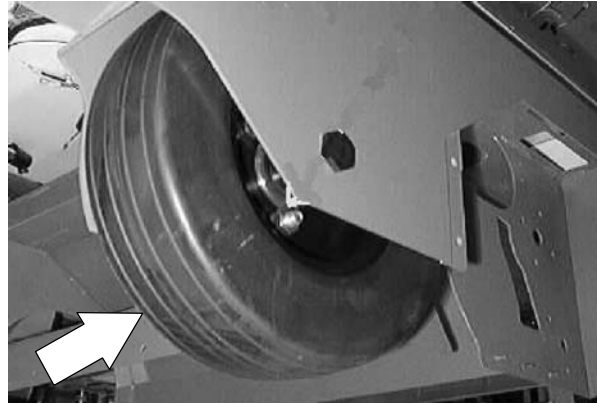

## TO REMOVE REAR TIRE

**FOR SAFETY: Before Leaving Or Servicing Machine; Stop On Level Surface, turn key switch OFF.**

1. Jack up the rear corner of the machine where the tire needs to be removed.

*NOTE: Do not raise both rear wheels off the floor at the same time. The machine will become unstable because of the single front tire.*



2. Go under the machine in the area of the rear tire. Locate the lock nut holding the axle shaft to the machine frame. Remove the lock nut and washer.

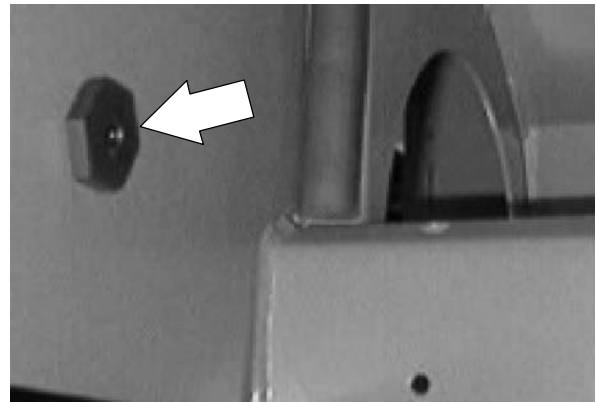

3. Support the tire while you pull the axle out of the wheel assembly. Drop the wheel assembly out of the machine.

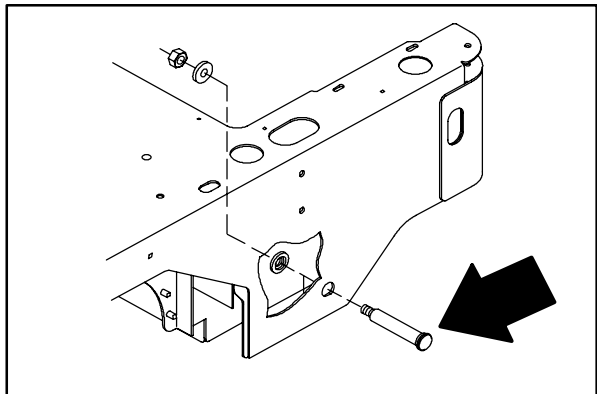

# T15 Maintenance & Repair

## TO INSTALL REAR TIRE

**FOR SAFETY: Before Leaving Or Servicing Machine; Stop On Level Surface, turn key switch OFF.**

1. Position the wheel assembly in the machine. (short side of hub toward outside) Raise the tire up and align the hole in the wheel bearing with the axle hole in the frame.

*NOTE: The lug nuts must face the outside of the machine.*

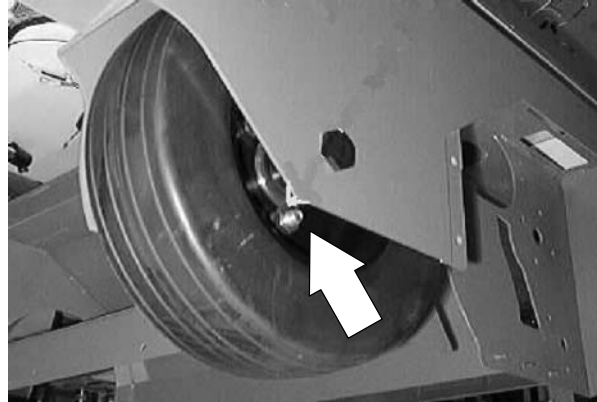

2. Install the axle shaft in the machine from the outside of the frame.

*NOTE: The axle has a flat portion that must line up with the flat in the axle mount hole.*

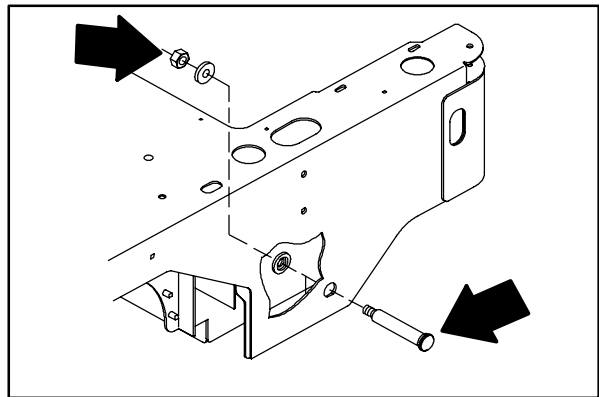

3. Install the washer and nut on the axle. Tighten to 68 - 81 Nm (50 - 60 ft lb).

4. Remove the jack stands and lower the machine.

5. Drive the machine and check for proper operation.

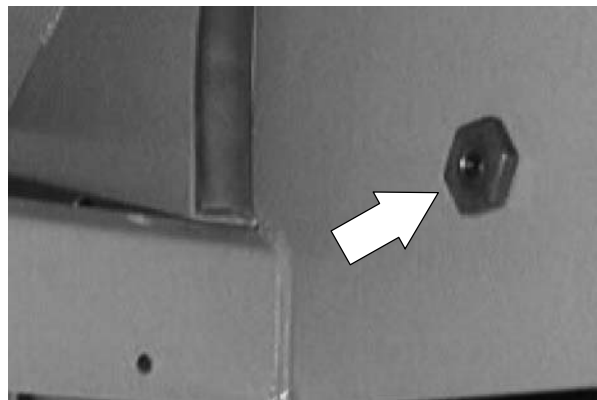

M



# T15 Maintenance & Repair

## TO REPLACE REAR WHEEL BEARINGS

**FOR SAFETY: Before Leaving Or Servicing Machine; Stop On Level Surface, turn key switch OFF.**

1. Remove the rear wheel assembly. See TO REMOVE REAR TIRE instructions.
2. Remove the three lug nuts holding the bearing housing to the wheel assembly. Remove the bearing housing.

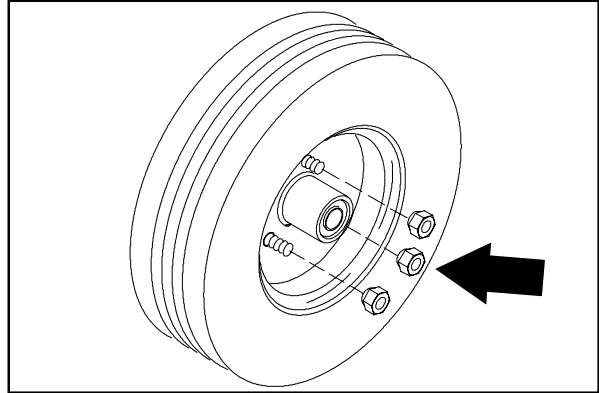

3. Use a press to remove the wheel bearings from the housing.

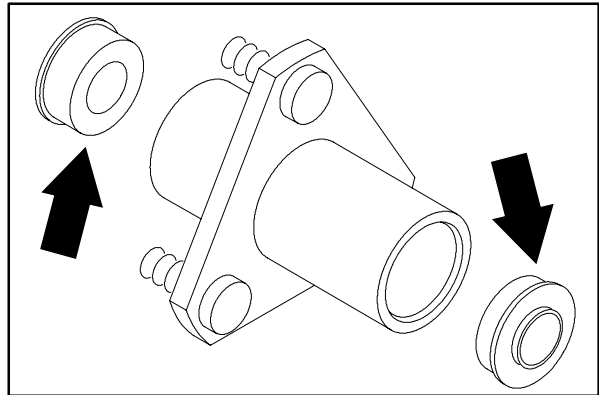

4. Press the new wheel bearings into the housing. Press the bearing in until the flange is seated on the housing.

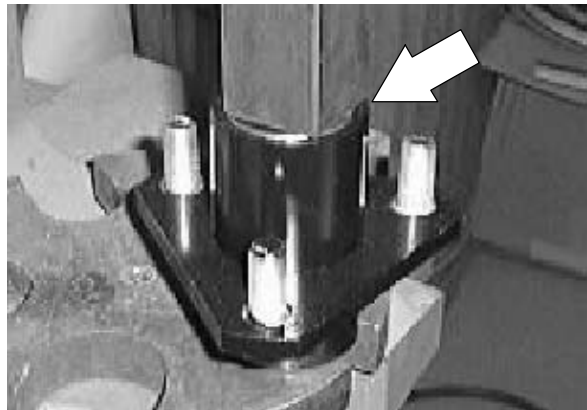

## T15 Maintenance & Repair

5. Reinstall the wheel on the bearing housing. (coining on wheel facing lug nuts) Tighten the three lug nuts to 58 - 76 Nm (43 - 56 ft lb).

*NOTE: The lug nuts must face the outside of the machine.*

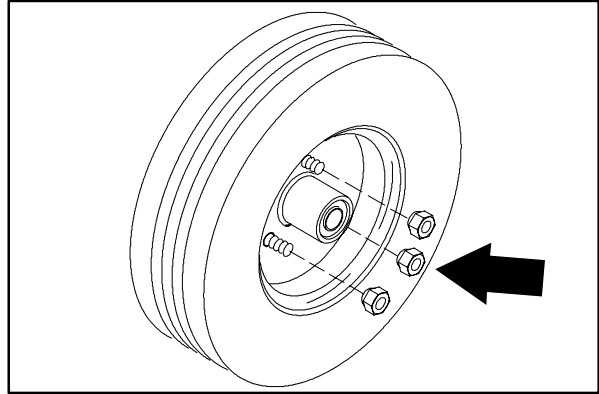

6. Reinstall the rear wheel assembly in the machine. See TO INSTALL REAR TIRE instructions.

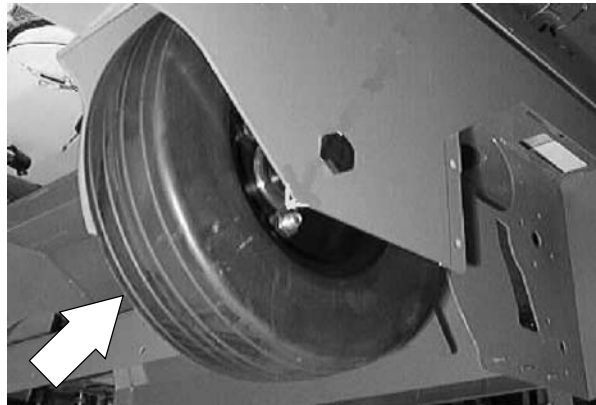

# T15 Maintenance & Repair

---

## FRONT TIRE AND WHEEL, AND WHEEL DRIVE SUPPORT

---

The front drive assembly controls the forward and reverse movement of the machine along with the braking and steering. The brake is released electrically and uses a sprocket and chain assembly for the steering. Forward and reverse is accomplished with an electric motor.

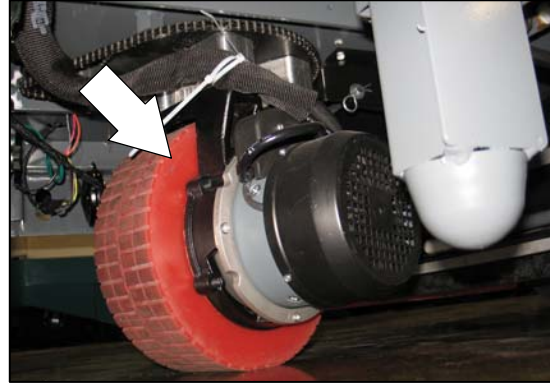

## FRONT WHEEL SUPPORT CASTER BEARING ASSEMBLY

The front wheel support caster bearing is located between the bottom swivel plate and the upper swivel plate weldment. The bearing is a flat needle bearing style.

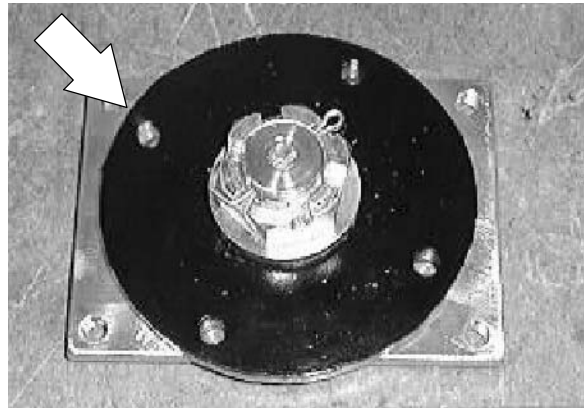

## TO REMOVE FRONT DRIVE ASSEMBLY

**FOR SAFETY: Before Leaving Or Servicing Machine; Stop On Level Surface, turn key switch OFF.**

1. Raise the seat support and unplug the battery connectors.
2. Raise the front of the machine and place jack stands under the frame.

# T15 Maintenance & Repair

3. Mark and remove the electrical cables leading to the drive motor.

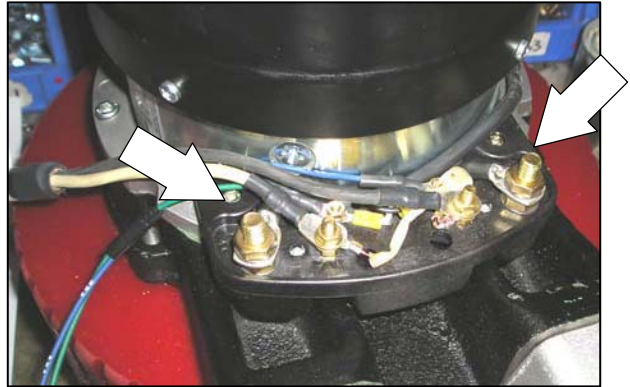

4. Go in operators compartment and loosen the lower steering shaft mount screws.

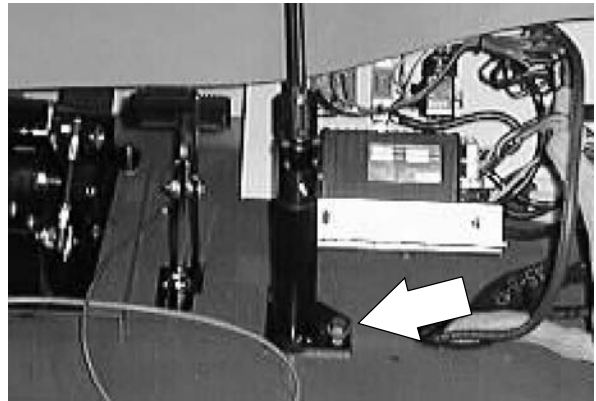

5. Pull the mount back to give the steering chain slack. Locate and remove the master link and steering chain.

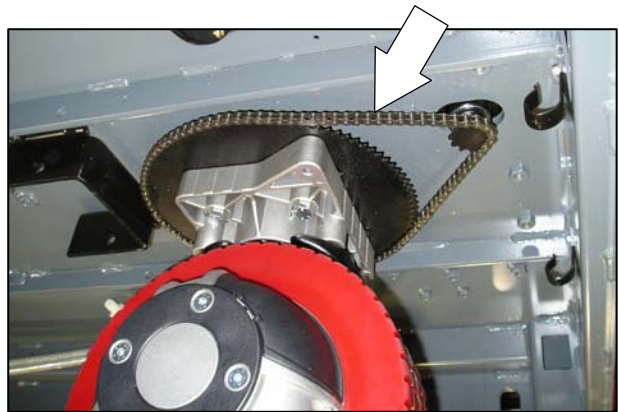

6. Position a floor jack or transmission jack under the drive wheel. This will support the drive assembly when the hardware is removed.
7. Go to the operators compartment and locate the 4 button head screws holding the drive assembly to the floor plate. Remove the 4 screws while supporting the drive assembly.
8. Remove the drive assembly from the machine.

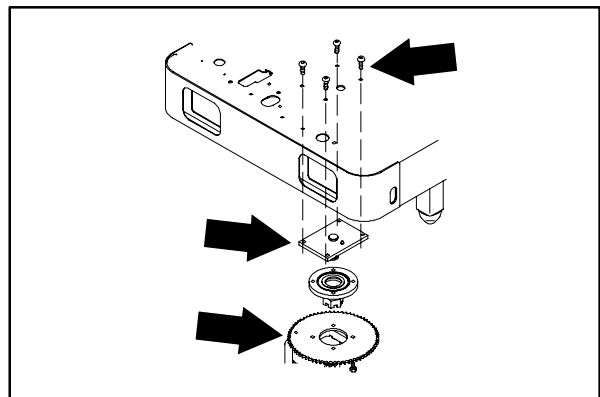

# T15 Maintenance & Repair

## TO INSTALL FRONT DRIVE ASSEMBLY

**FOR SAFETY: Before Leaving Or Servicing Machine; Stop On Level Surface, turn key switch OFF.**

1. Raise the seat support and unplug the battery connectors.
2. Raise the front of the machine and place jack stands under the frame.
3. Place the front drive assembly on a floor jack or transmission jack. This will support the drive assembly when installing it in the machine.
4. Position the drive assembly under the machine in front.
5. Raise the drive assembly up until the mount holes in the floor plate are aligned with the mount holes in the upper swivel plate weldment on top of the drive assembly.

*NOTE: Make sure to position the grease zerk in the access hole in the machine floor plate.*

6. Install the four button head screws and tighten to 64 - 83 Nm (47 - 61 ft lb).
7. Reinstall the steering chain and master link. Adjust the steering chain. See TO ADJUST STEERING CHAIN instructions.

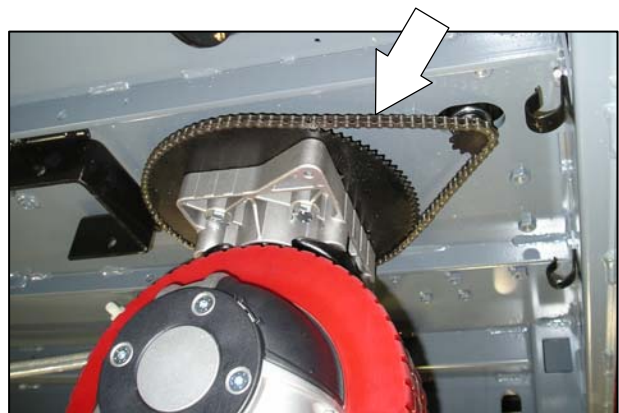
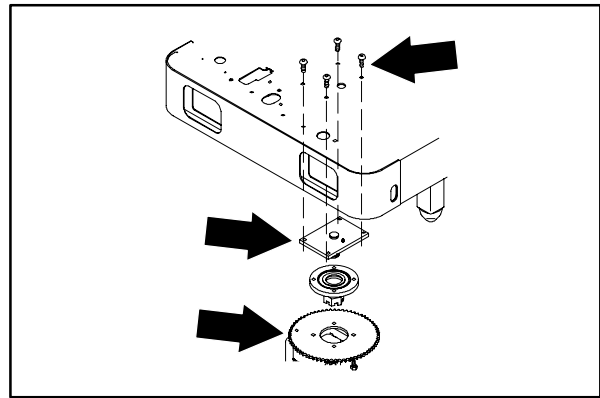

8. Reinstall the electrical cables on the drive motor.
9. Remove the jack stands and lower the machine.
10. Reconnect the battery cables.
11. Operate the machine and check for proper operation.

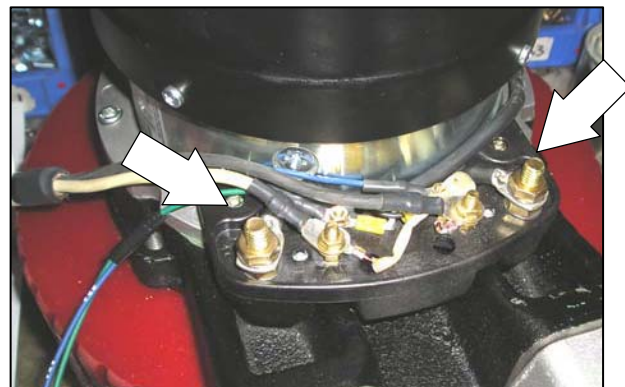

# T15 Maintenance & Repair

## Propel Motor Service

### Exploded View

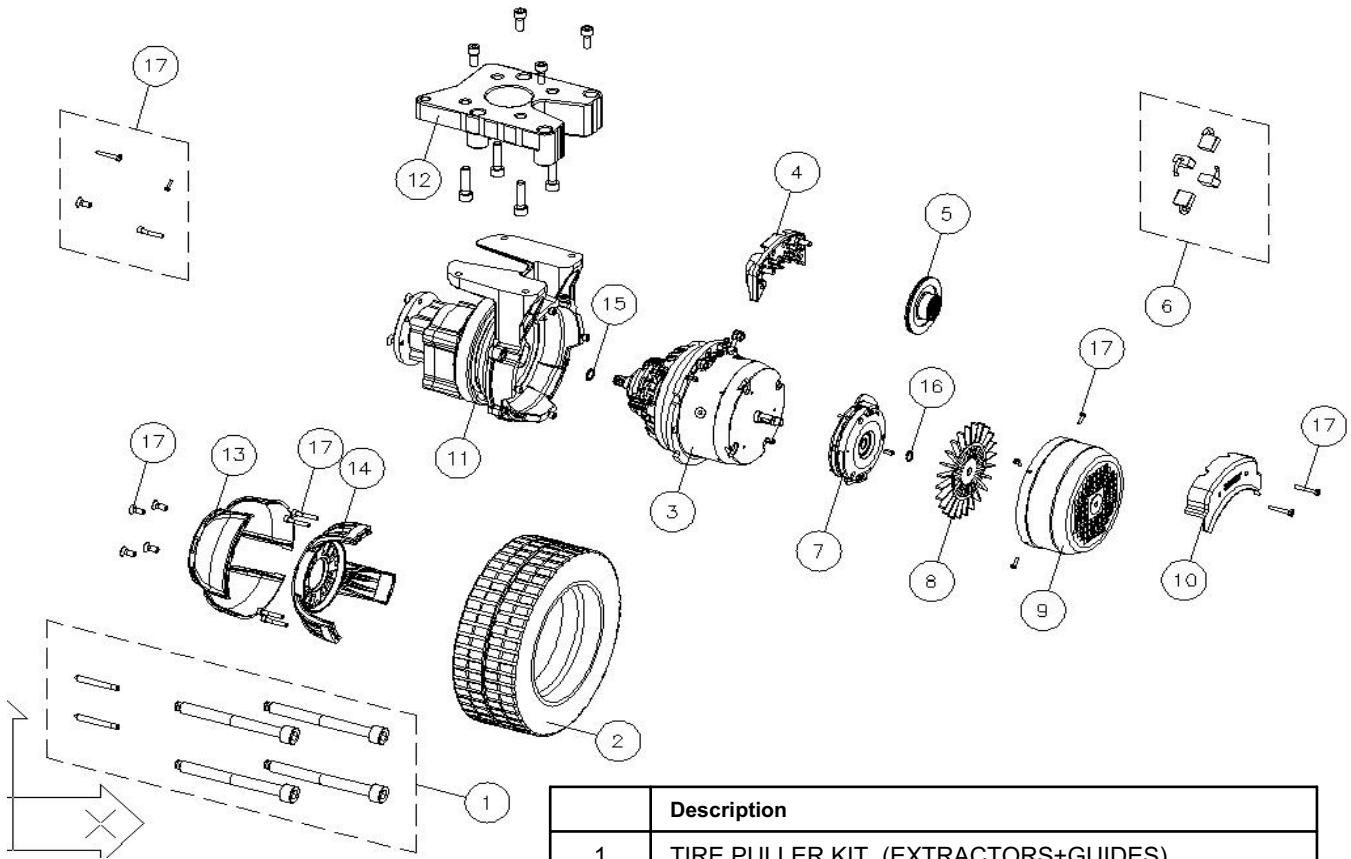

#### **General information**

Oil type : AGIP BLASIA 150

Oil quantity : 130g (4.5 oz)

Brake Air gap : 0.3mm

Thread system : METRIC

Brushes check : every 1000 hours

	Description
1	TIRE PULLER KIT (EXTRACTORS+GUIDES)
2	RED POLYURETHANE WHEEL 300X100
3	COMPLETE MOTOR ASSEMBLY
4	CONNECTION BOX
5	BRAKE ROTOR
6	BRUSH KIT (4 PCS.)
7	COMPLETE ELECTROMAGNETIC BRAKE WITH LEVER
8	FAN
9	PROTECTIVE COVER FOR MOTOR
10	CONNECTION BOX COVER
11	BALL BEARING 91962 2RS
12	ALUMINIUM SPACER
13	PLASTIC COVER FOR ALUMINIUM HUB
14	ALUMINIUM HUB
15	SEAL RING
16	RETAINING RING
17	SCREW KIT

# T15 Maintenance & Repair

## Propel Motor Service

### Terminal Connections

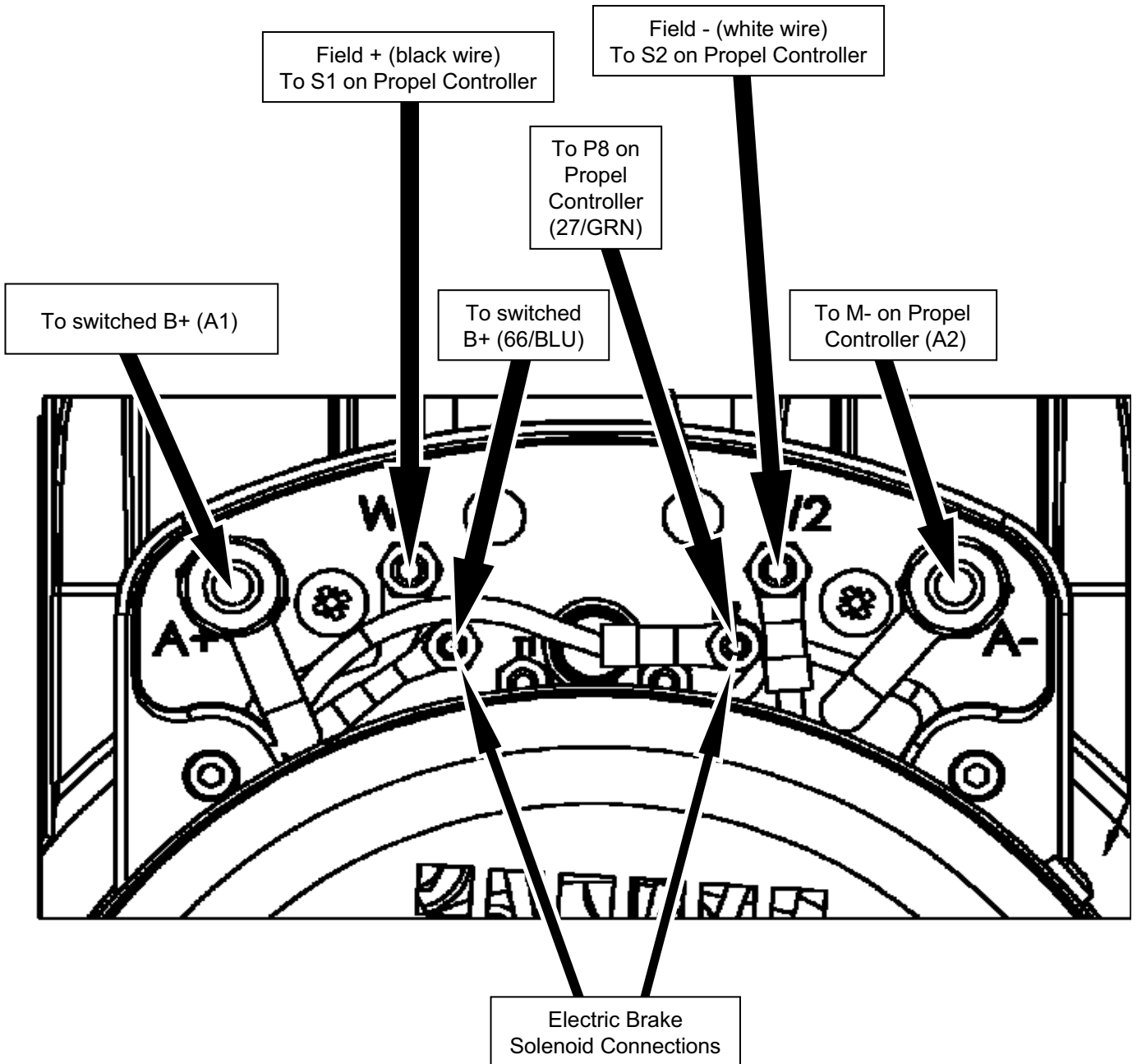

# T15 Maintenance & Repair

## Propel Motor Service

Electric Brake Disassembly (page 1 of 4)

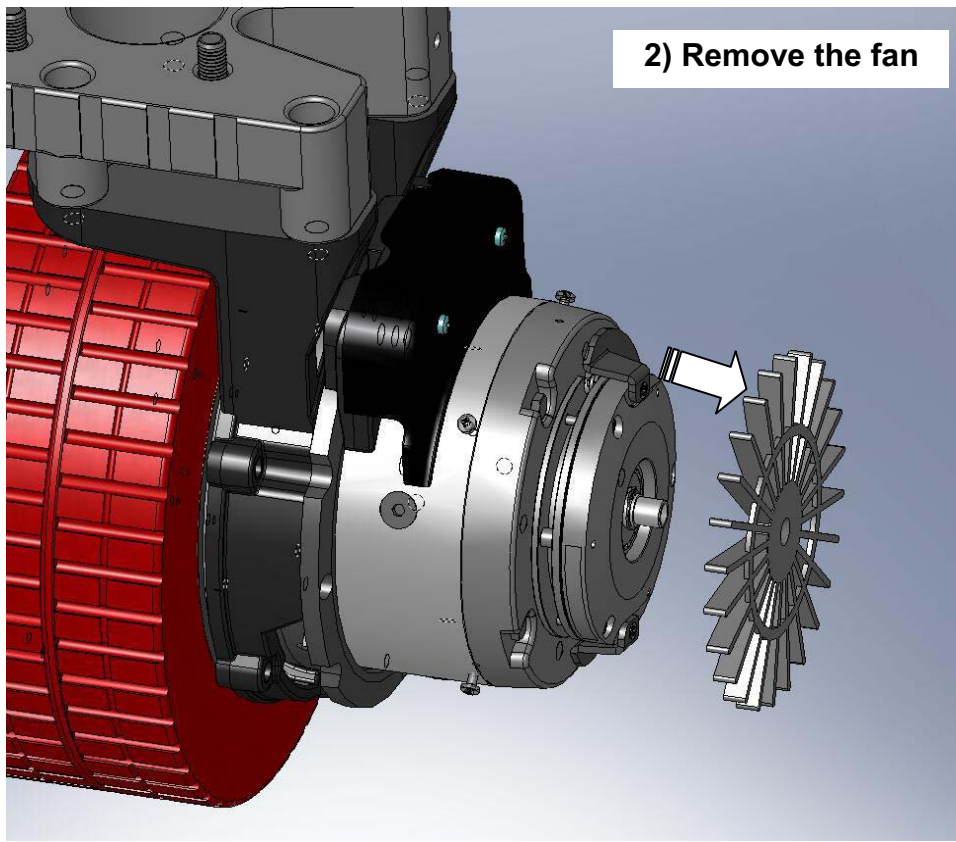
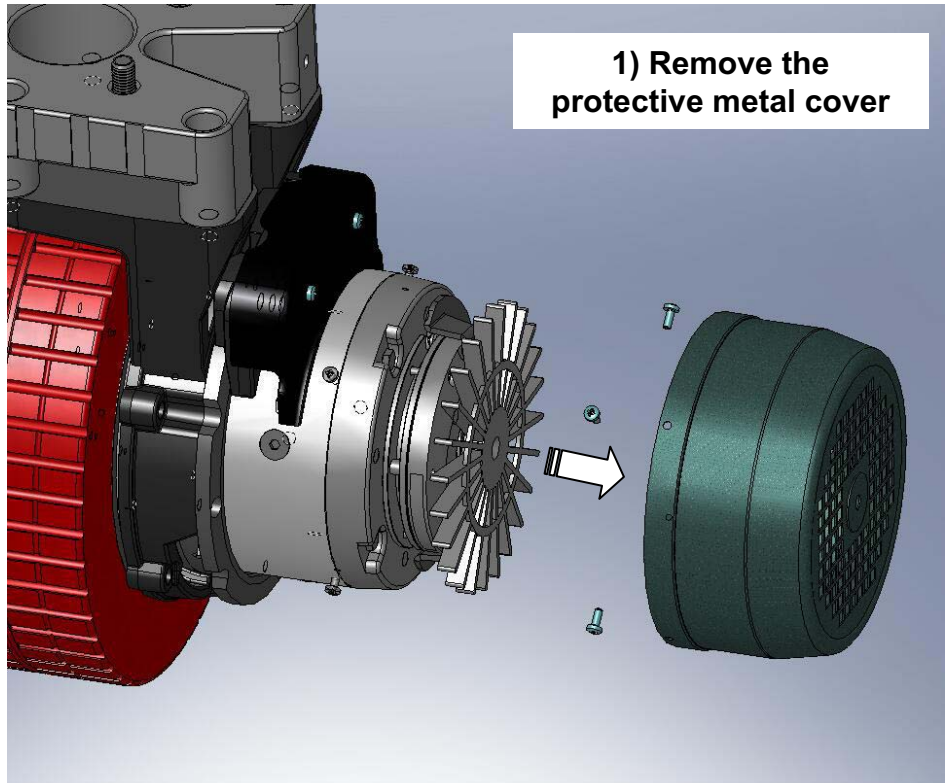



# T15 Maintenance & Repair

## Propel Motor Service

### Electric Brake Disassembly (page 2 of 4)

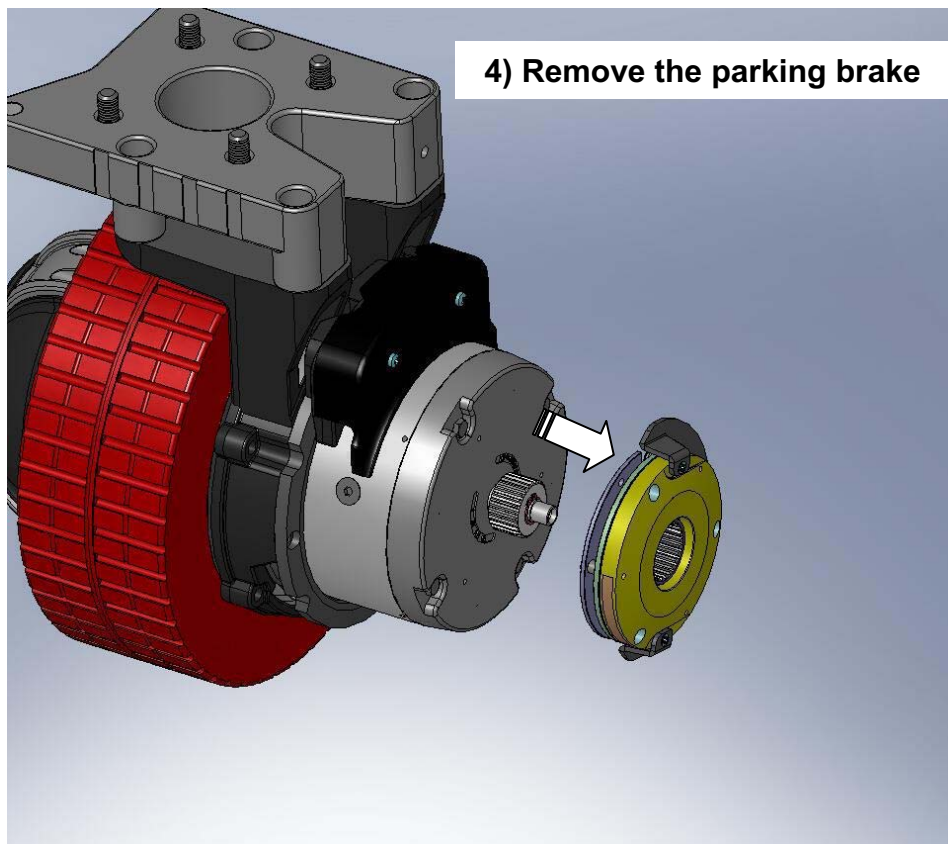
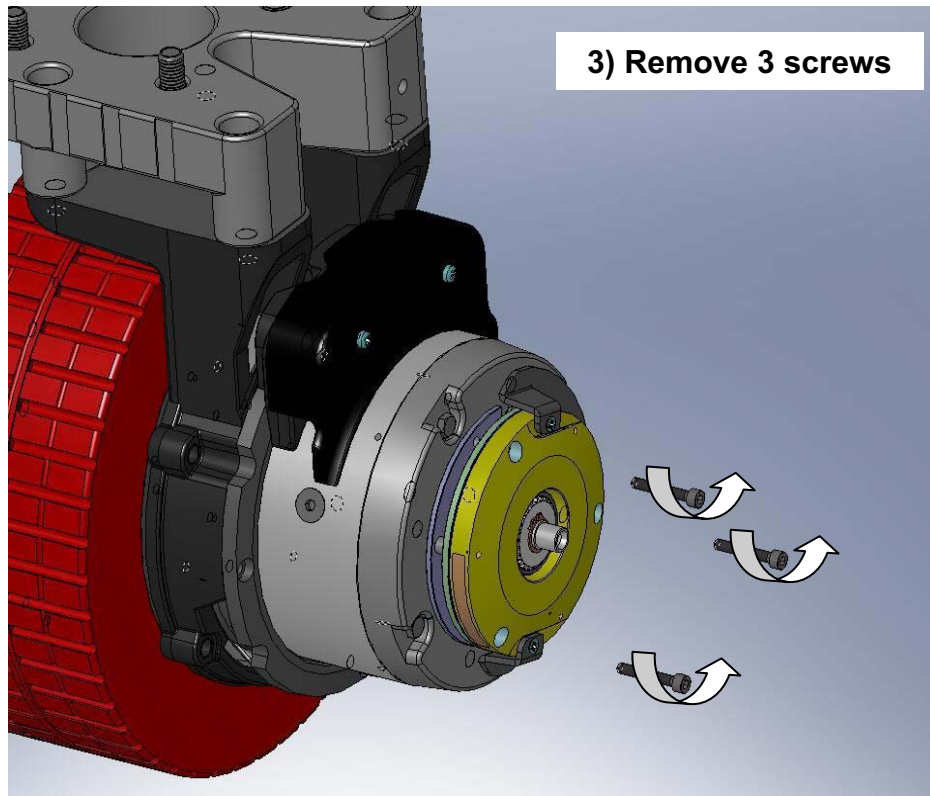

# T15 Maintenance & Repair

## Propel Motor Service

Electric Brake Disassembly (page 3 of 4)

M

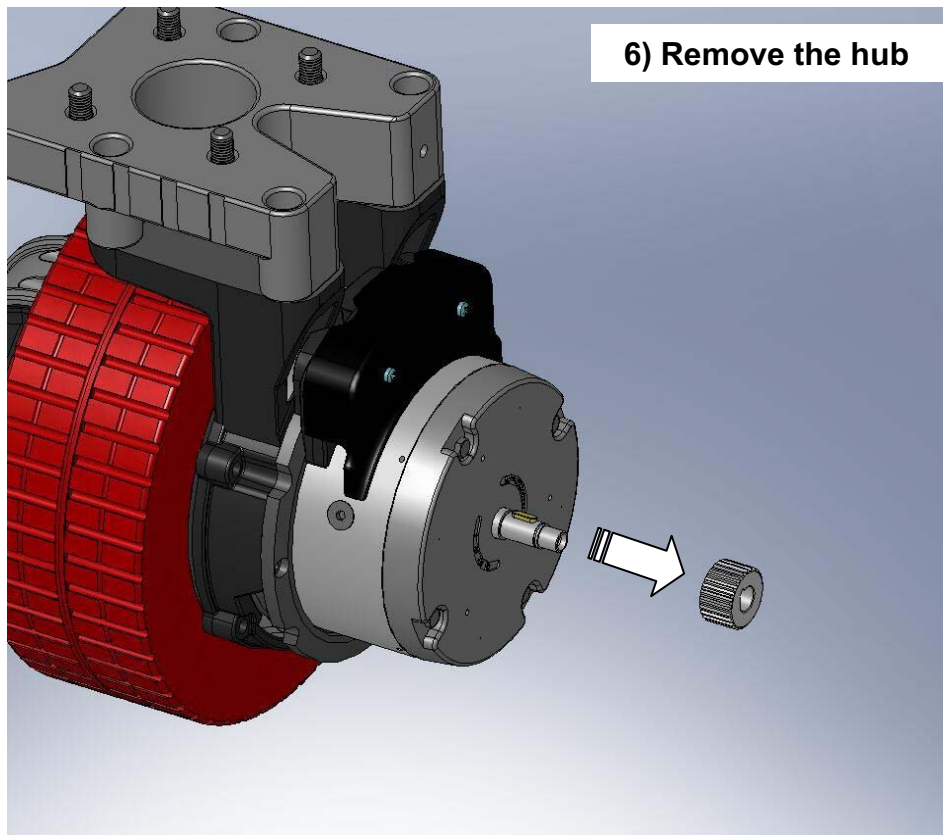
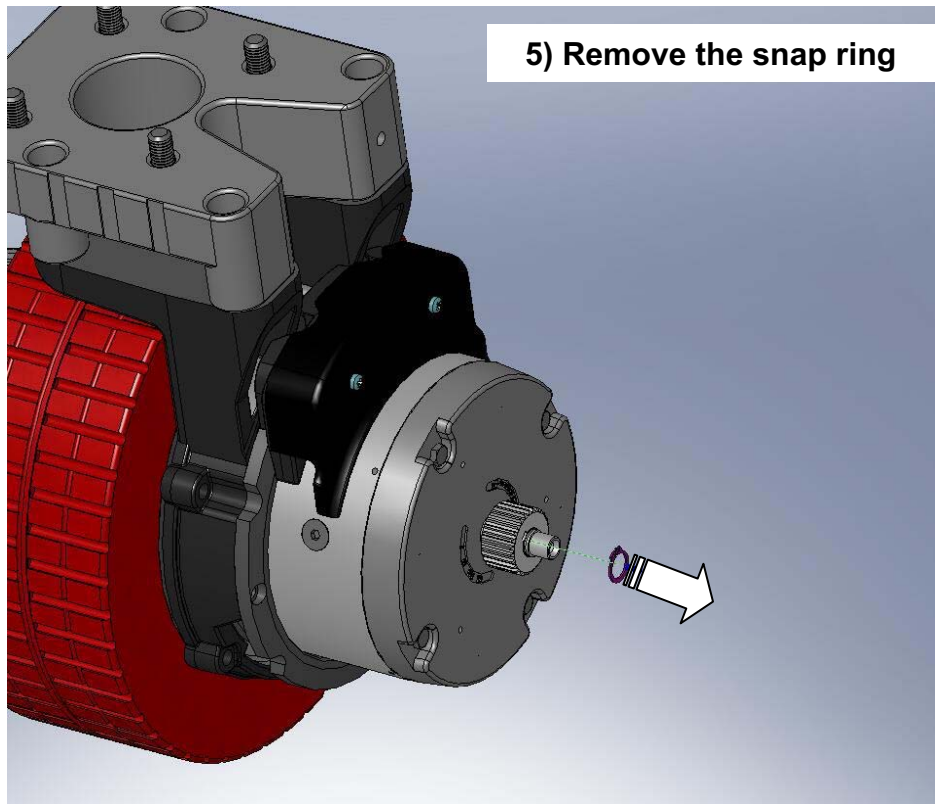

# T15 Maintenance & Repair

## Propel Motor Service

Electric Brake Disassembly (page 4 of 4)

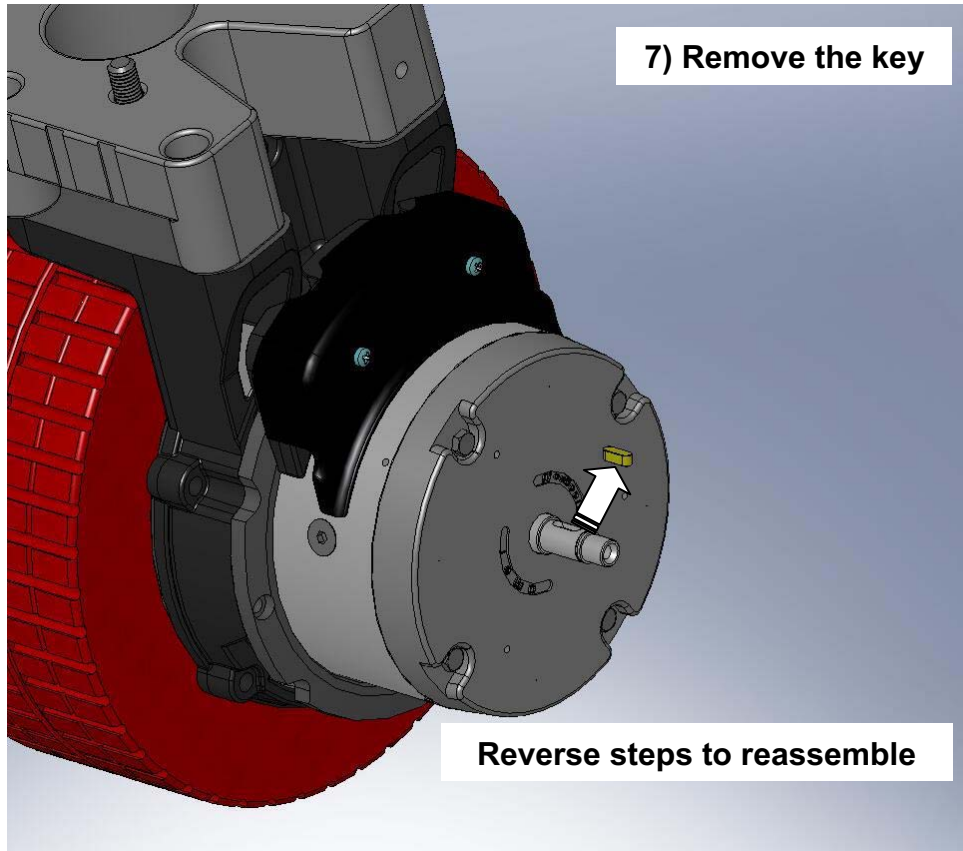

# T15 Maintenance & Repair

## Propel Motor Service

### Brake Disk Replacement

M

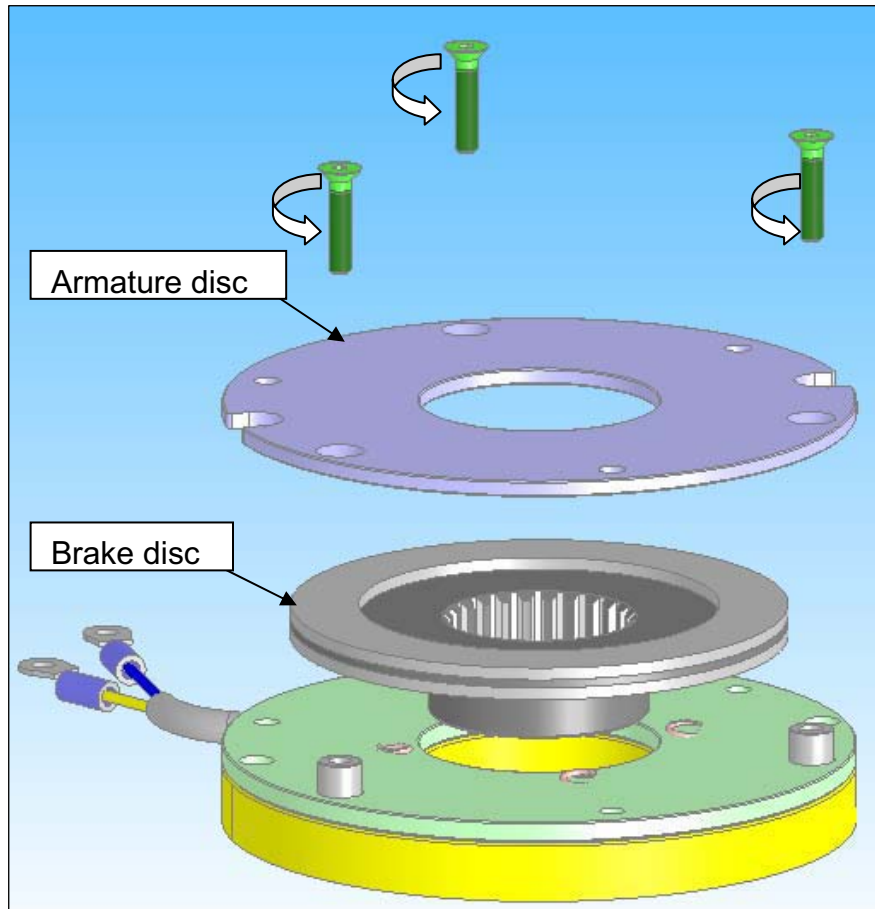

**Remove the 3 screws and replace the brake disc.**

**The brake disc must be changed when it reaches 50% wear. The new brake disc has a thickness of 2.2mm, and must be changed when it is worn down to 1.1mm.**

# T15 Maintenance & Repair

## Propel Motor Service

Tire Replacement (page 1 of 4)

### 1) Remove 4 screws from the hub

**WARNING :**  
Lift the machine so that the tire is not touching the ground.

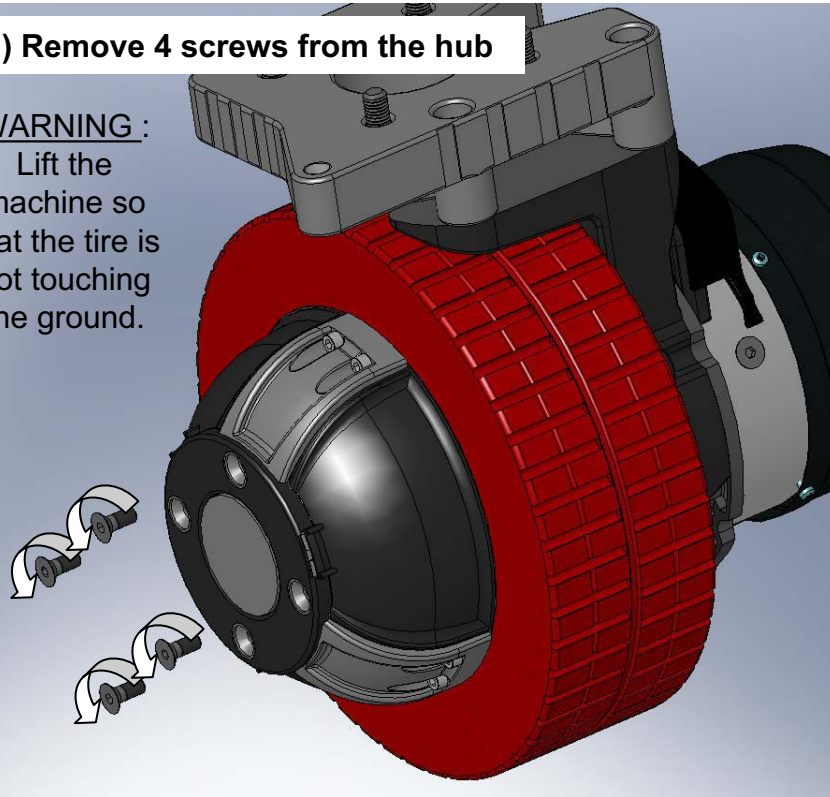

### 2) Screw the 4 puller screws into the bracket until the hub is removed

**WARNING :**  
Remove the 4 puller screws after this operation

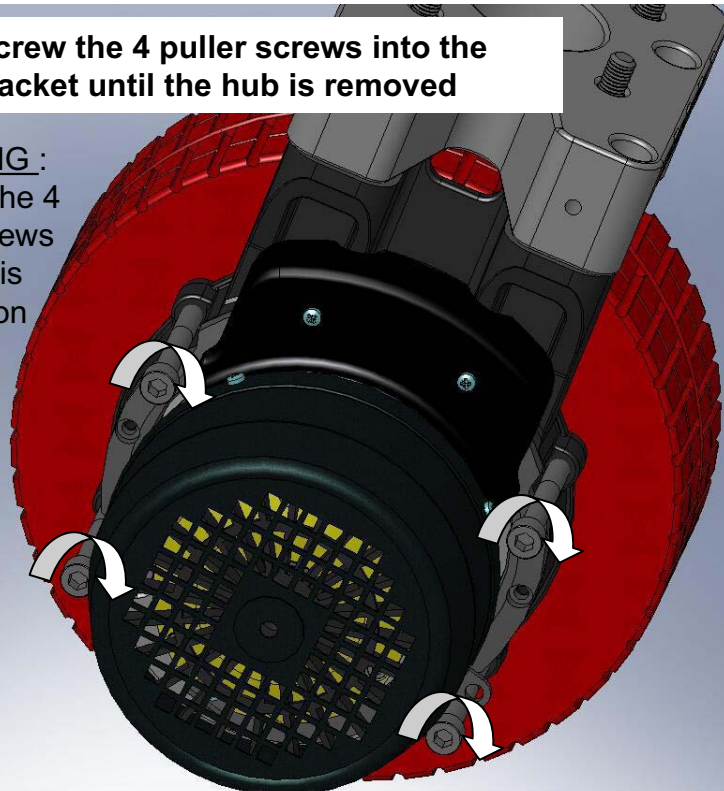

# T15 Maintenance & Repair

## Propel Motor Service

Tire Replacement (page 2 of 4)

M

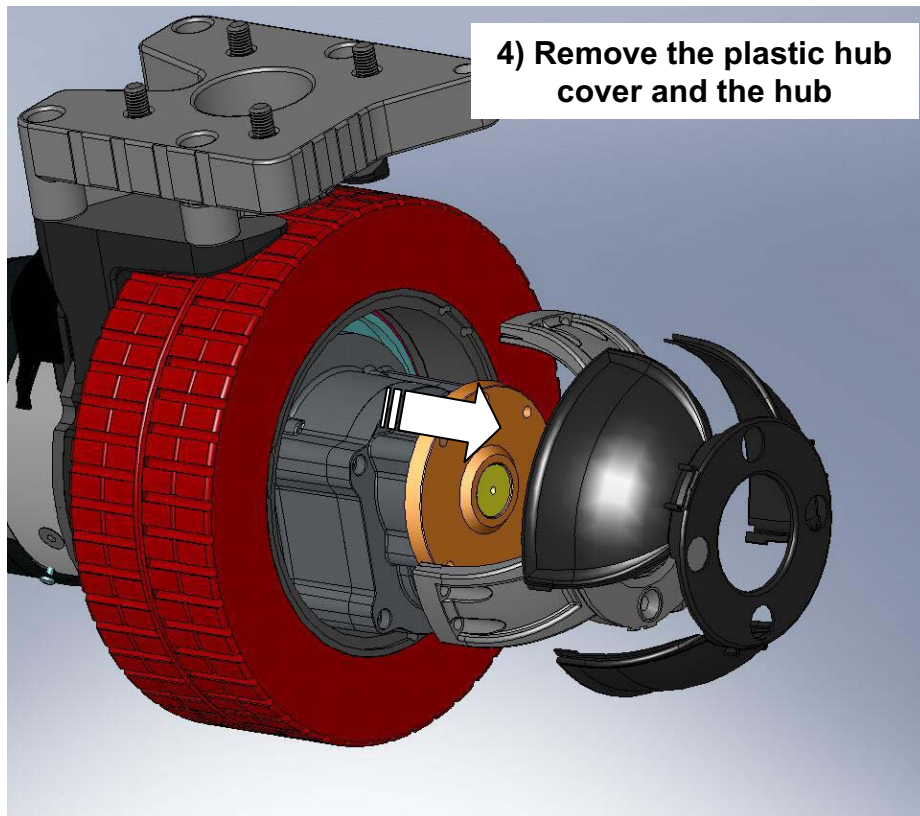
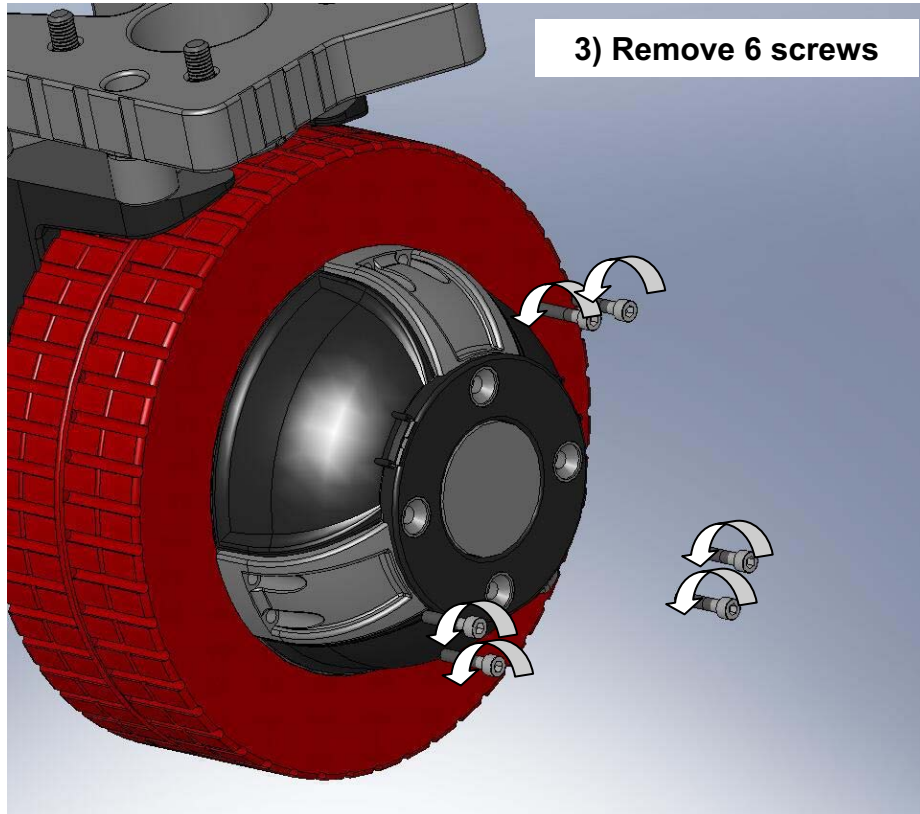

# T15 Maintenance & Repair

## Propel Motor Service

### Tire Replacement (page 3 of 4)

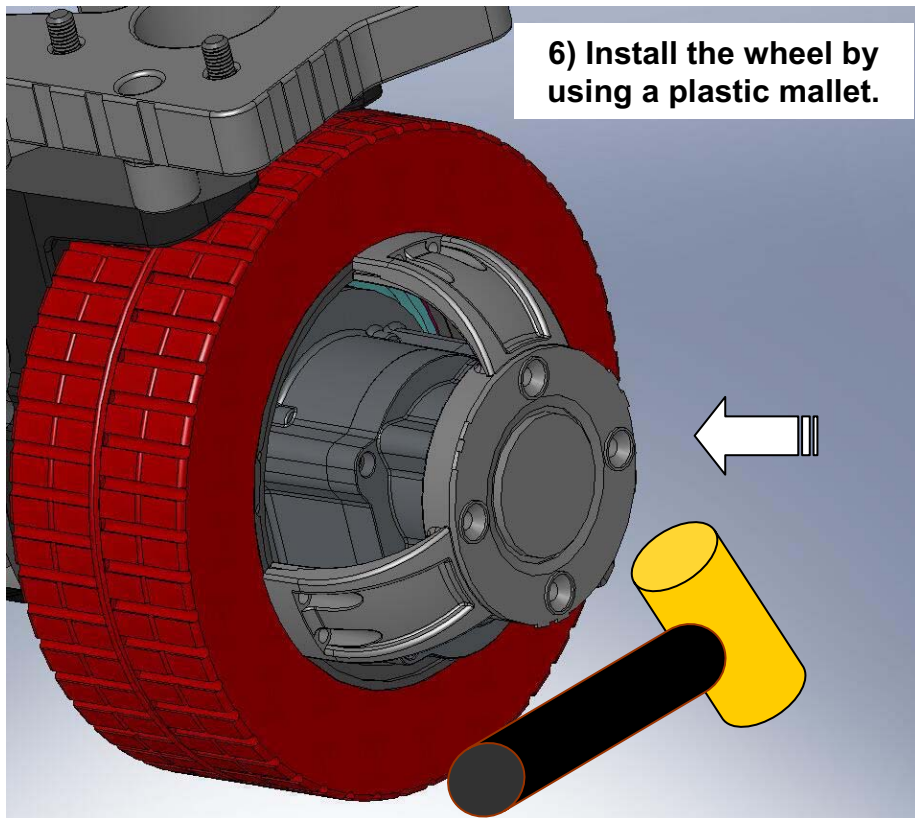
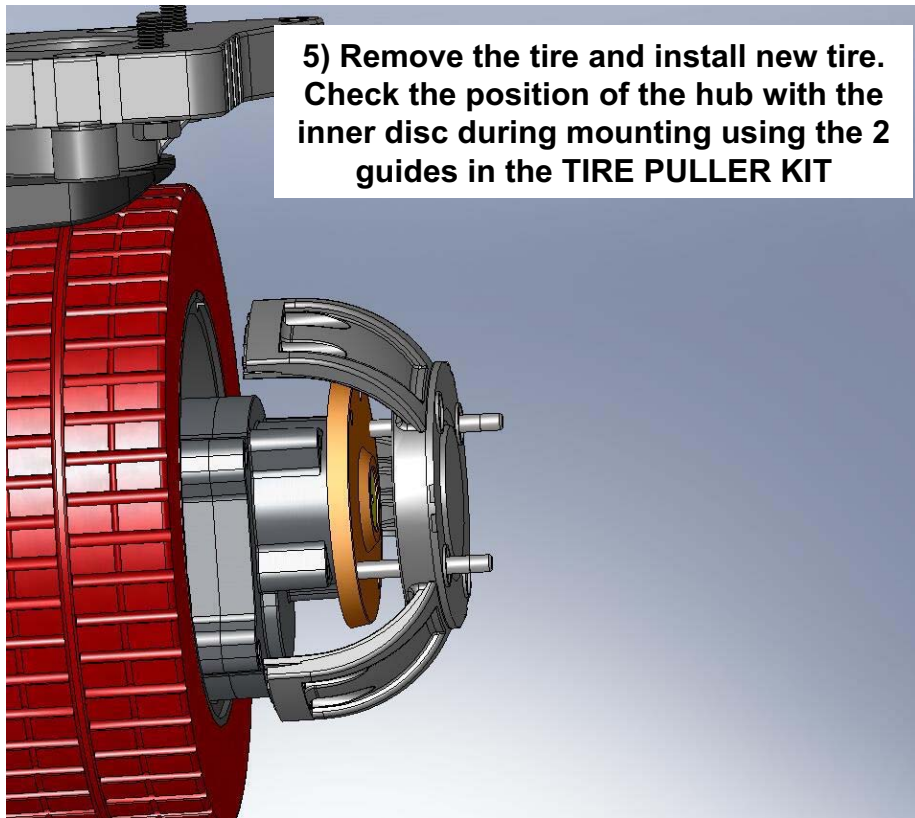

# T15 Maintenance & Repair

## Propel Motor Service

Tire Replacement (page 4 of 4)

M

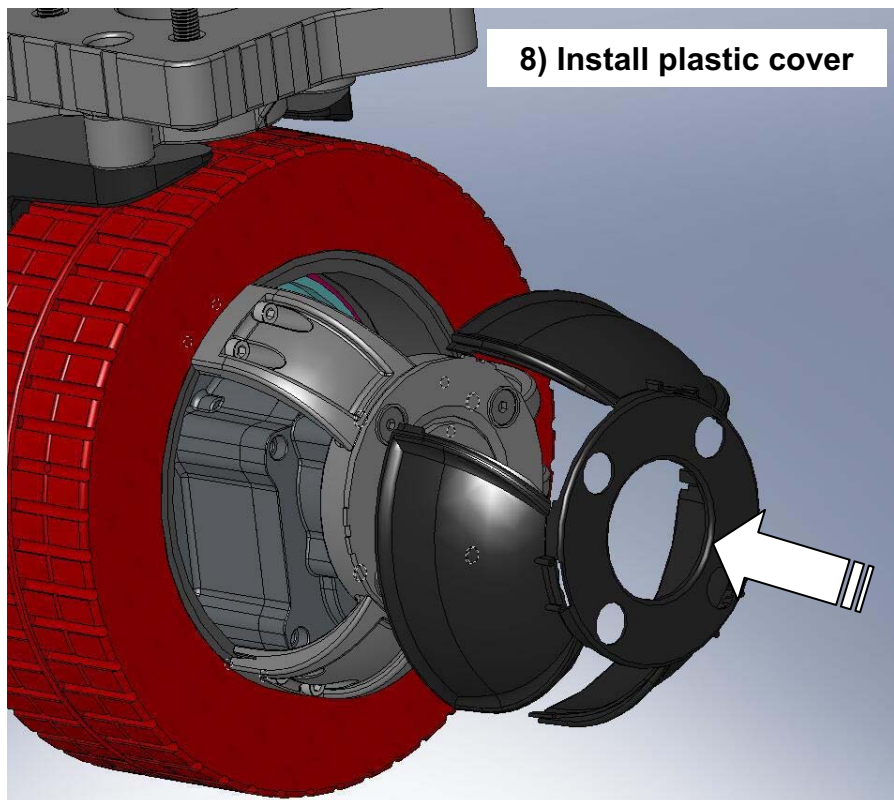
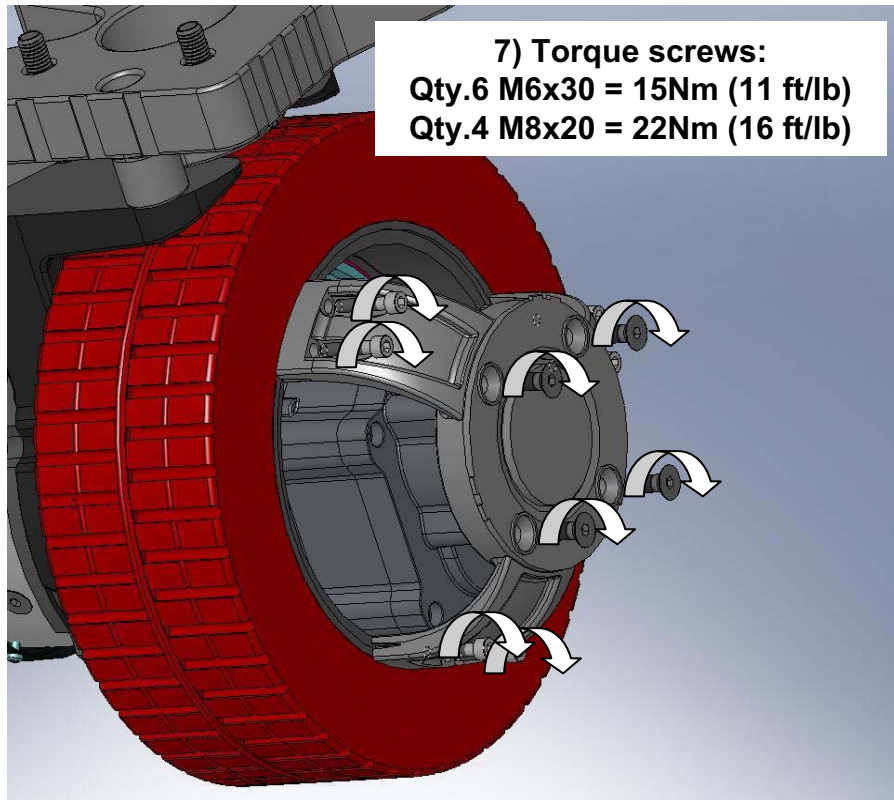



# T15 Maintenance & Repair

## Propel Motor Service

Commutator Brush Replacement (page 1 of 3)

1) Remove 2 screws, then remove connection box cover

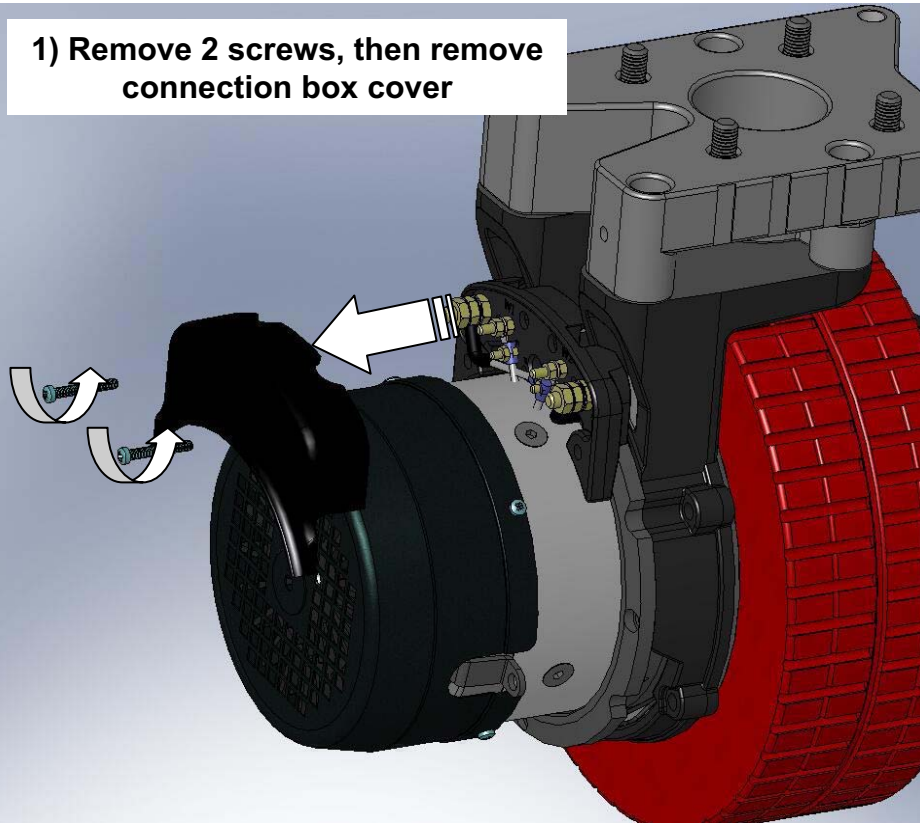

2) Remove 4 screws then remove motor

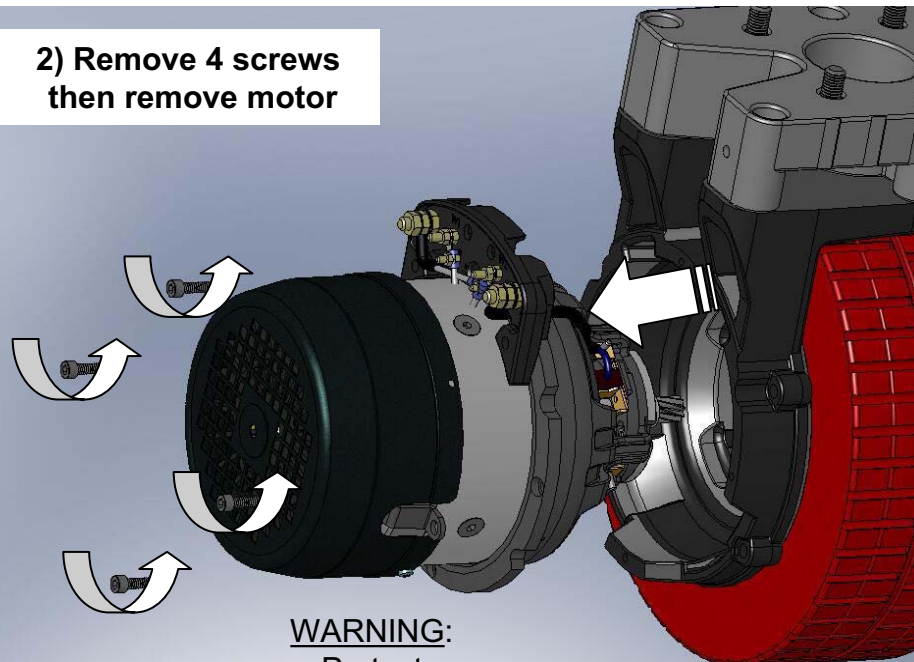

**WARNING:**  
Protect components from dirt while disassembled



# T15 Maintenance & Repair

## Propel Motor Service

Commutator Brush Replacement (page 2 of 3)

M

**3) Remove nut, washer, and brush**

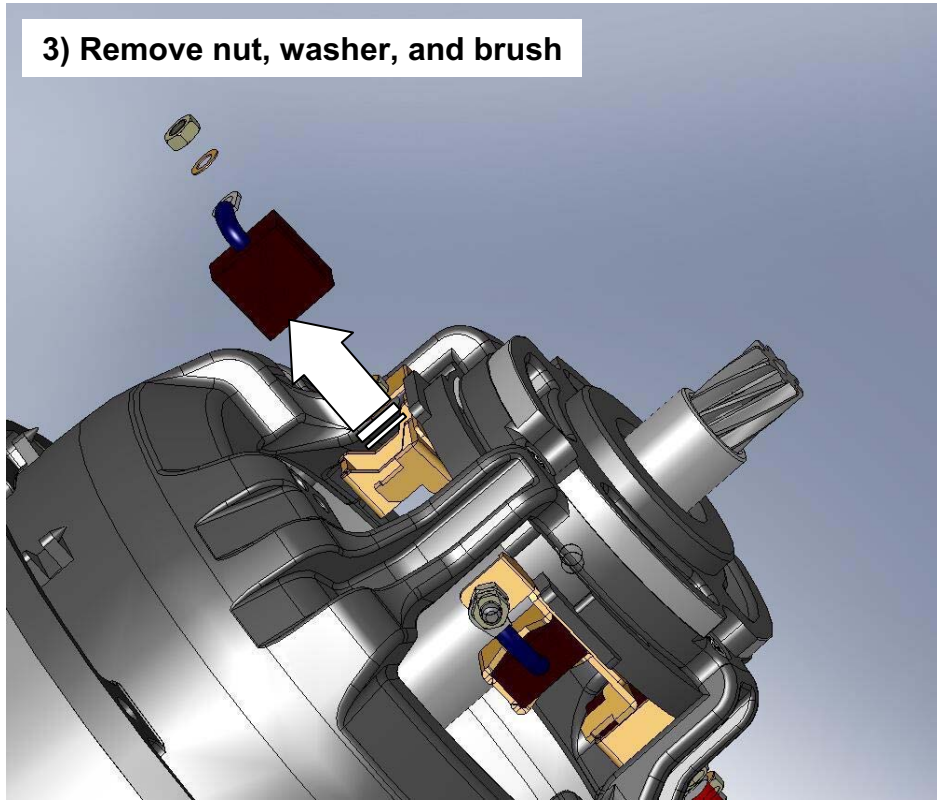

**4) Install new brushes – be sure brushes move freely in brush holder**

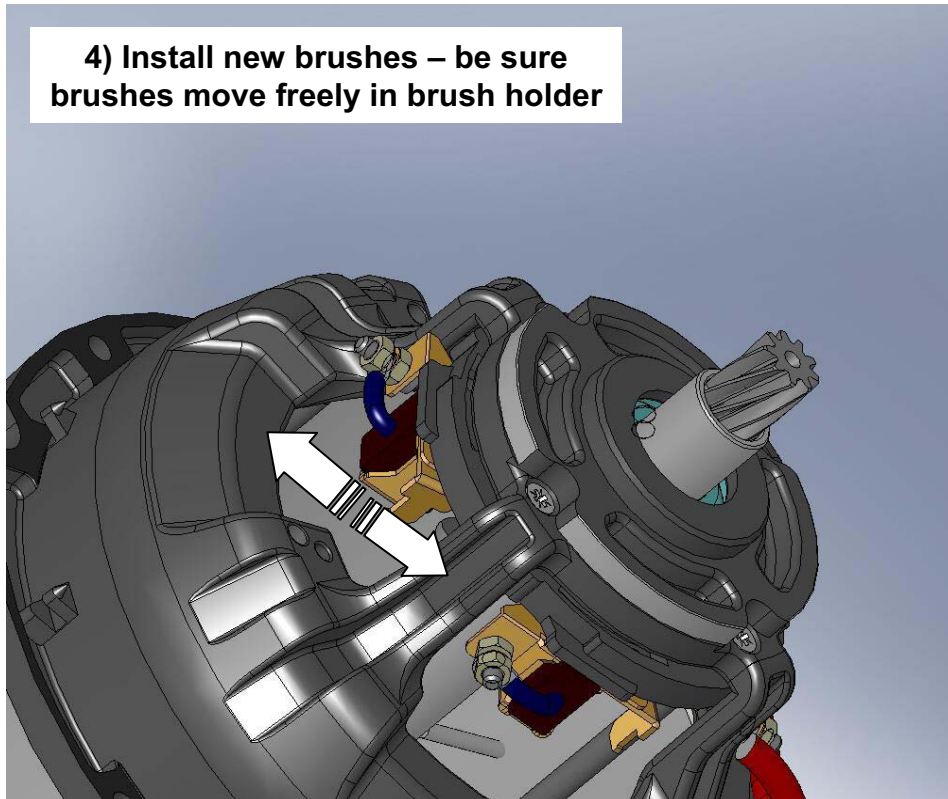

# T15 Maintenance & Repair

## Propel Motor Service

Commutator Brush Replacement (page 3 of 3)

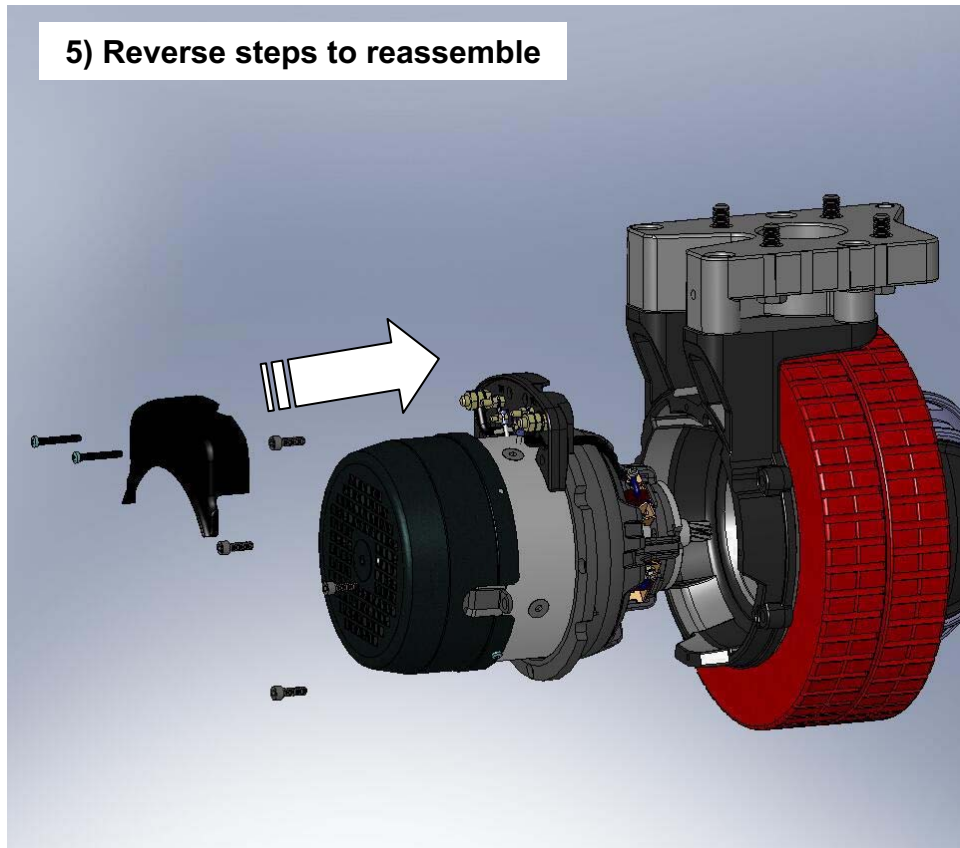

**NOTE: CHECK BRUSHES EVERY 1000 hours**

**Brush length new = 19 mm**  
**Brush wear limit = 9 mm**

# T15 Maintenance & Repair

## TO REPLACE DRIVE ASSEMBLY CASTER BEARING AND THRUST WASHERS

**FOR SAFETY: Before Leaving Or Servicing Machine; Stop On Level Surface, turn key switch OFF.**

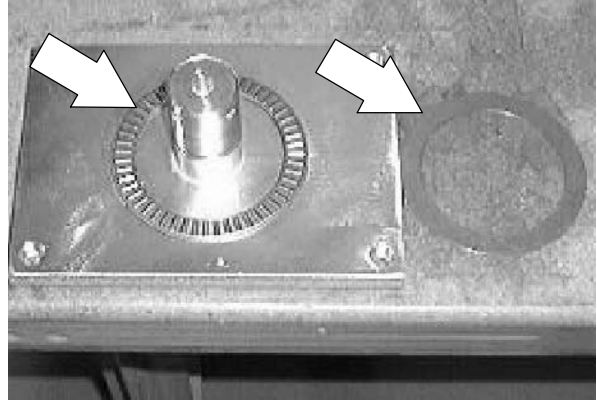

1. Remove the drive assembly from the machine. See TO REMOVE FRONT DRIVE ASSEMBLY instructions.

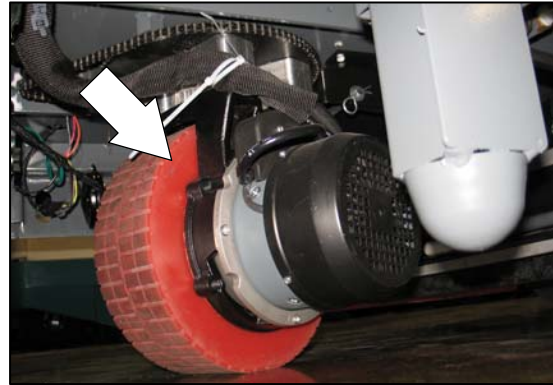

2. Remove the four hex screws holding the pivot and sprocket assembly to the drive assembly.

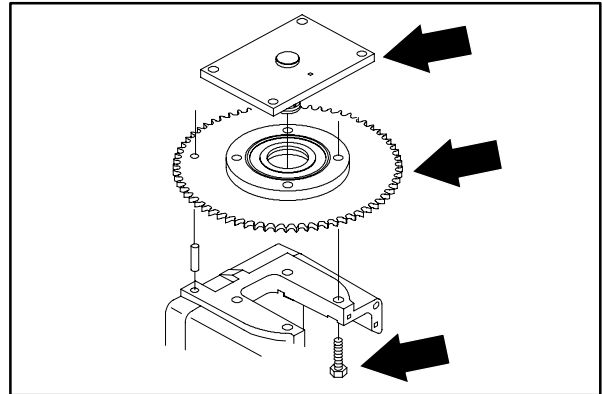

3. Remove the sprocket from the pivot assembly.

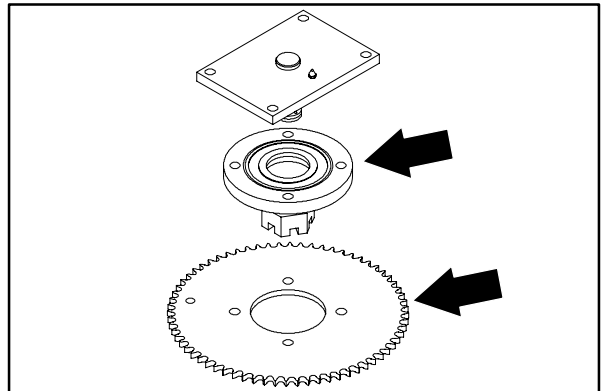

# T15 Maintenance & Repair

4. Remove the cotter pin and castle nut from the upper swivel plate weldment.
5. Remove the flat washer and cone bearing from the bottom swivel plate.

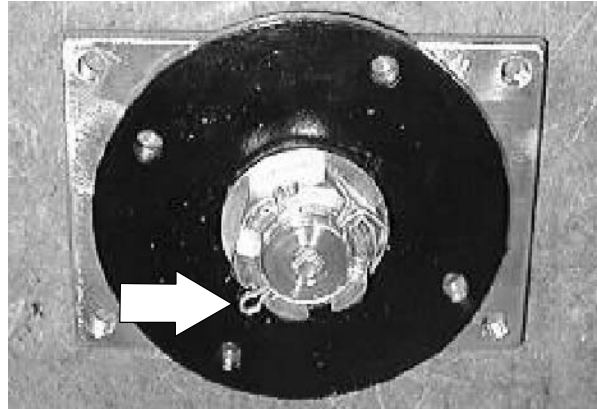

6. Lift the bottom swivel plate off the upper swivel plate weldment.

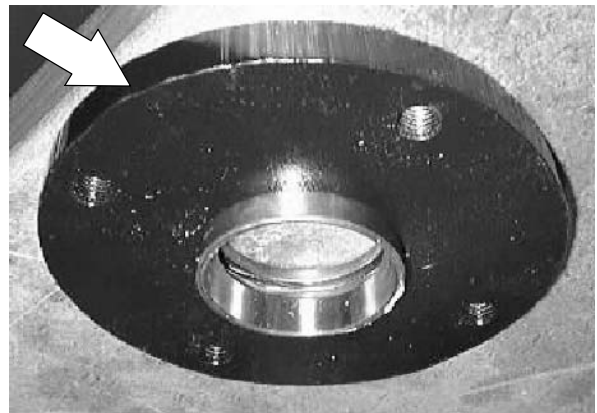

7. Remove and discard both thrust washers and the caster bearing from the upper swivel plate weldment.

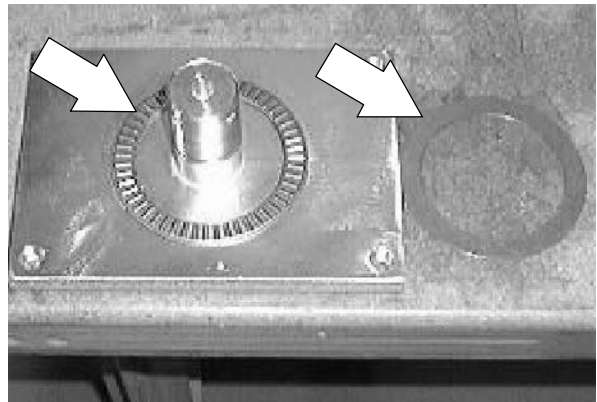

8. Apply grease on both sides of the new caster bearing.
9. Position the new caster bearing on top of the new lower thrust washer.
10. Reinstall the second new thrust washer on top of the new caster bearing.

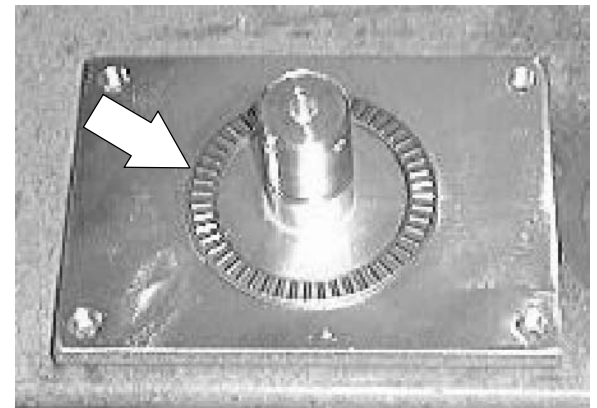

# T15 Maintenance & Repair

11. Reinstall the bottom swivel plate on the upper swivel plate weldment. Make sure the grease seal is in place on the upper swivel plate weldment.

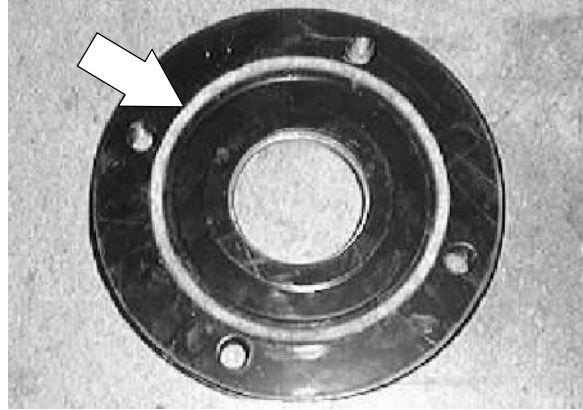

12. Reinstall the bearing cone and flat washer on the bottom swivel plate. Make sure the bearing cone is greased.

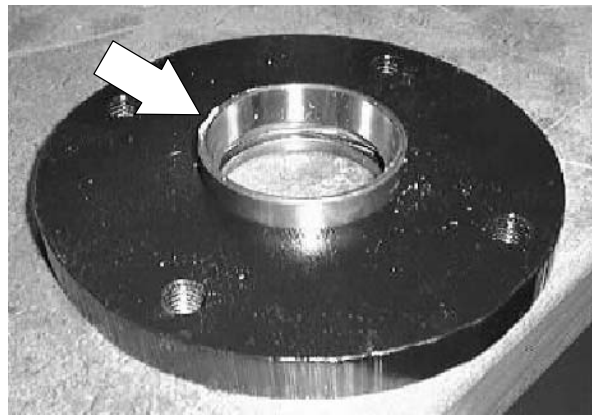

13. Reinstall the castle nut and tighten to (125 ft lbs). Then back off to the next nearest hole and install the cotter pin. Check to make sure the caster bearing can be turned by hand. Reduce torque if necessary.

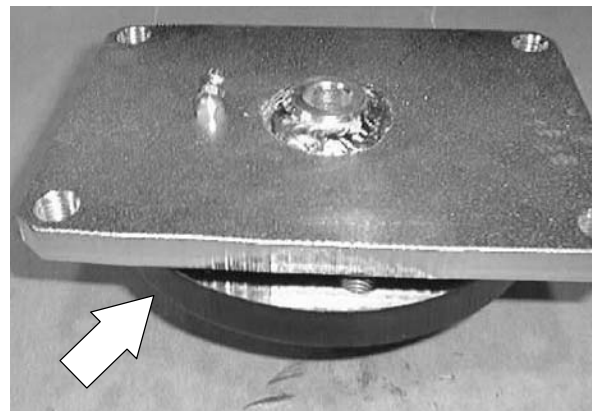

14. Reinstall the sprocket on the front drive assembly.
15. Reinstall the pivot and sprocket assembly on the drive assembly. Reinstall the four screws and tighten to 68 - 81 Nm (50 - 60 ft lb).
16. Reinstall the drive assembly in the machine. See TO INSTALL FRONT DRIVE ASSEMBLY instructions.
17. Operate the machine and check for smooth steering operation.

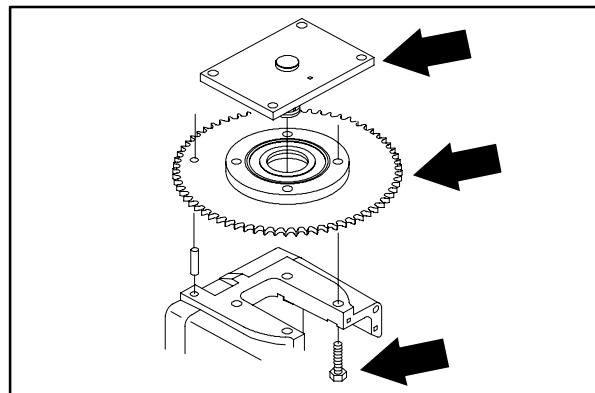

# T15 Maintenance & Repair

## TO REPLACE DRIVE ASSEMBLY PIVOT CONE BEARING

**FOR SAFETY: Before Leaving Or Servicing Machine; Stop On Level Surface, turn key switch OFF.**

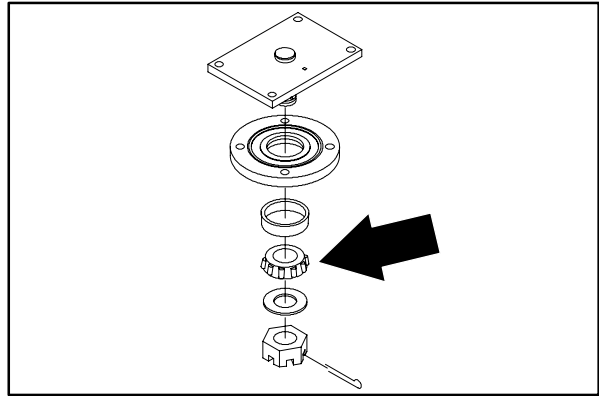

1. Remove the drive assembly from the machine. See TO REMOVE FRONT DRIVE ASSEMBLY instructions.

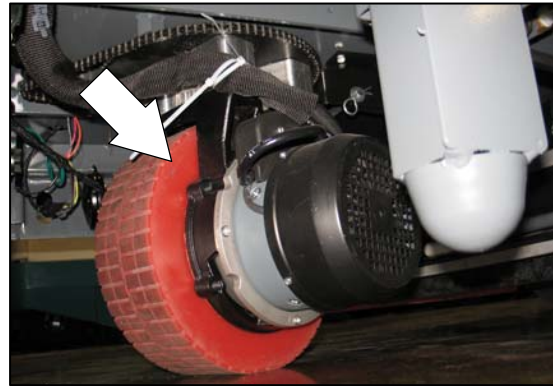

2. Remove the four hex screws holding the pivot and sprocket assembly to the drive assembly.
3. Remove the sprocket from the pivot assembly.

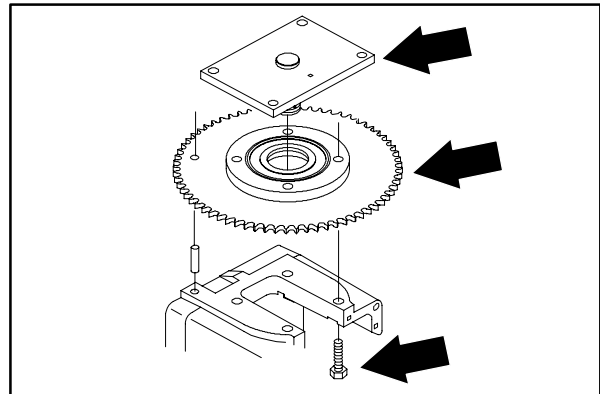

4. Remove the cotter pin and castle nut from the upper swivel plate weldment.

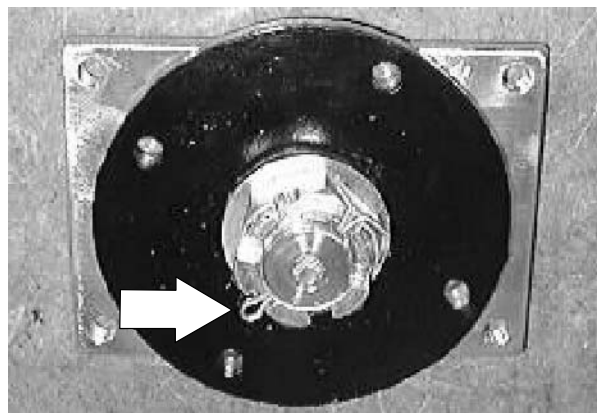

# T15 Maintenance & Repair

5. Remove the flat washer and old cone bearing from the bottom swivel plate.
6. Install the new cone bearing and flat washer on the bottom swivel plate. Make sure the new cone bearing is greased.
7. Reinstall the castle nut and tighten to 200 Nm (150 ft lbs). Then tighten to the next nearest hole and install the cotter pin.

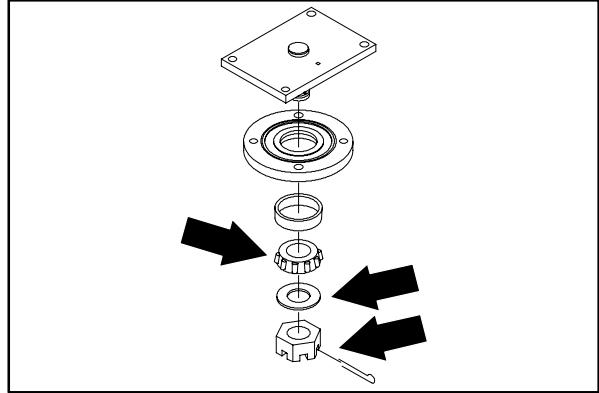

8. Reinstall the sprocket on the pivot assembly.

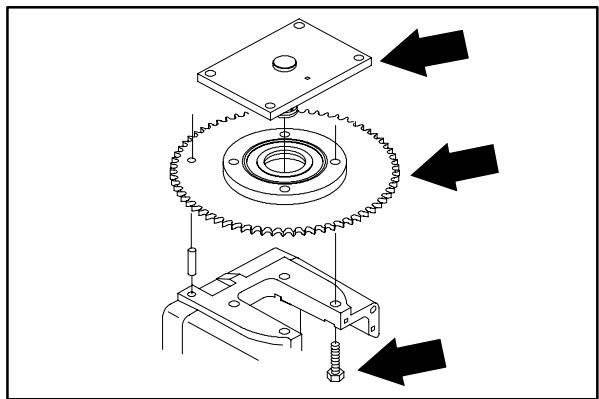

9. Reinstall the pivot and sprocket assembly on the drive assembly. Reinstall the four screws and tighten to 68 - 81 Nm (50 - 60 ft lb).

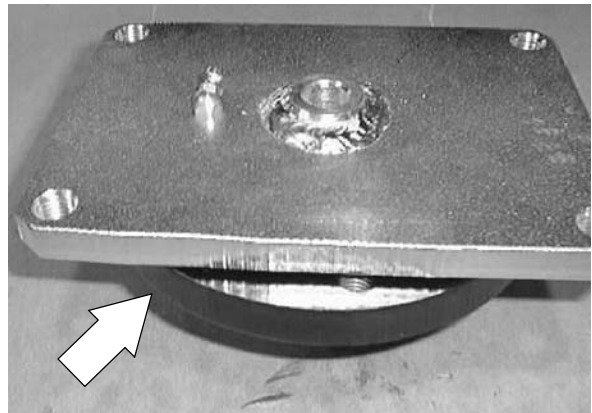

10. Reinstall the drive assembly in the machine. See TO INSTALL FRONT DRIVE ASSEMBLY instructions.

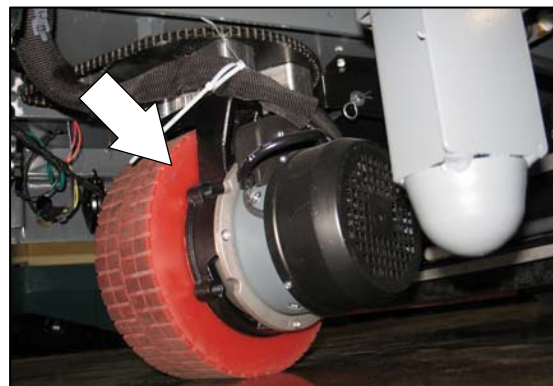

11. Operate the machine and check for smooth steering operation.





# T15 Maintenance & Repair

---

## STEERING

---

The steering on the model T15 is controlled with two sprockets and one chain. A large diameter sprocket is mounted on the top of the front drive assembly and a small diameter sprocket is mounted on the bottom of the steering shaft. The steering chain runs around both of these sprockets.

After extended use, the steering chain may stretch slightly. Any slack in the chain can be removed by following the adjustment procedure listed below.

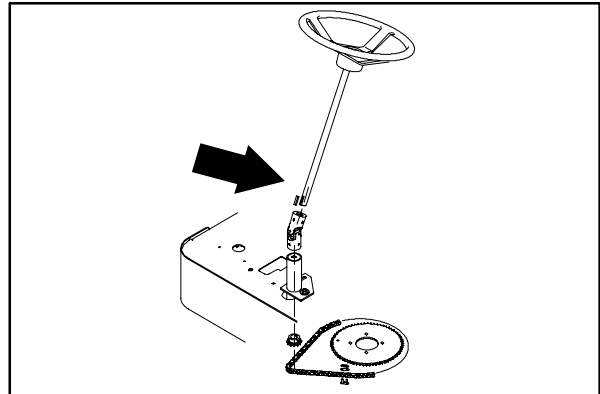

### TO ADJUST STEERING CHAIN

**FOR SAFETY: Before Leaving Or Servicing Machine; Stop On Level Surface, turn key switch OFF.**

1. Go into the operators compartment and locate the two hex screws holding the lower steering shaft bearing assembly to the floor plate. Loosen these two hex screws.

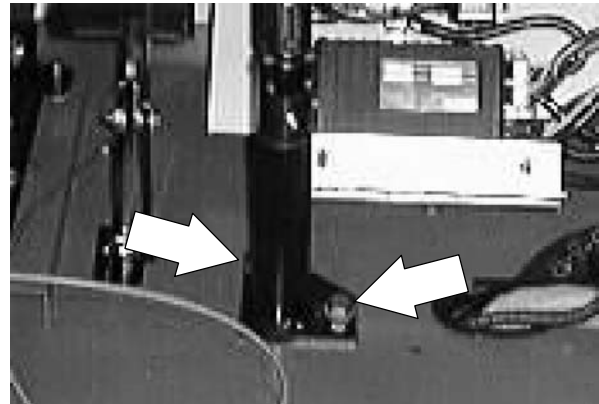

2. Push the lower steering shaft assembly forward until the slack has been removed from the steering chain. Tighten the two hex screws to 18 - 24 Nm (15 - 20 ft lb).
3. Operate the machine and check the steering for proper operation.

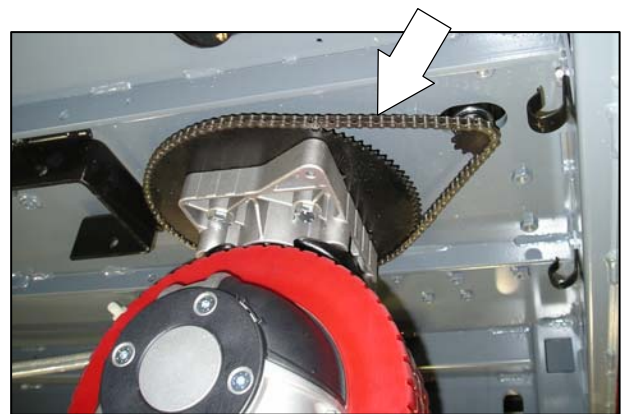

*NOTE: There is also a half link that can be removed for more adjustment.*



# T15 Maintenance & Repair

## TO REPLACE STEERING CHAIN

**FOR SAFETY: Before Leaving Or Servicing Machine; Stop On Level Surface, turn key switch OFF.**

1. Raise the seat support and unplug the battery connectors.
2. Raise the front of the machine and place jack stands under the frame.
3. Go under the machine and locate the steering chain.

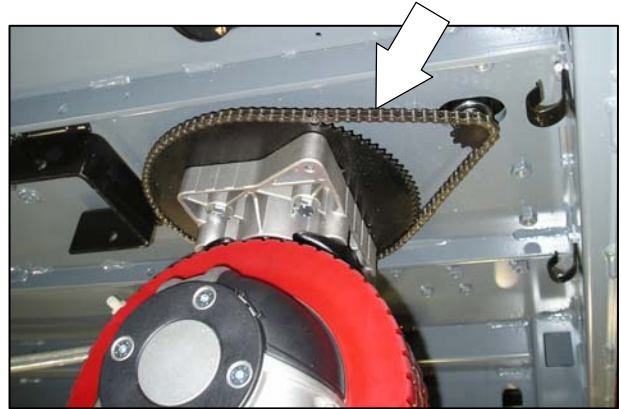

4. Rotate the steering wheel until the master link on the chain is accessible.
5. Remove the chain master link. Remove the steering chain from both sprockets.
6. Remove and discard the steering chain from the machine.

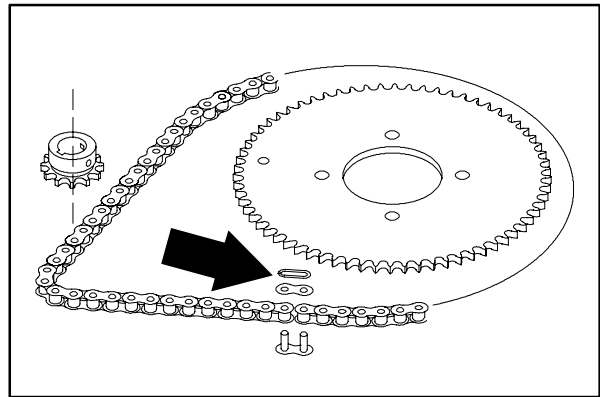

7. Route the new chain around both steering sprockets. Install the master link.
8. Remove the jack stands and lower the machine.
9. Operate the machine and check the steering for proper operation.

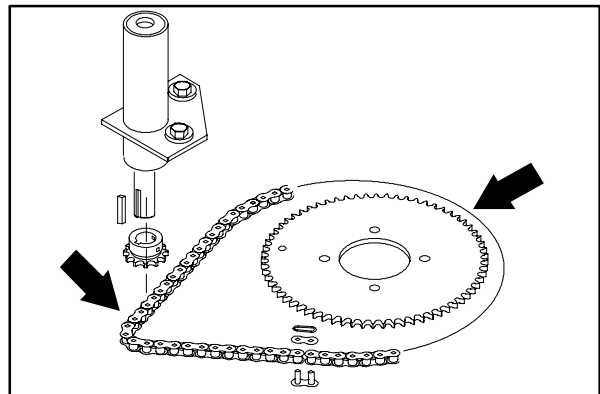

# T15 Maintenance & Repair

## TO REPLACE LARGE STEERING SPROCKET

**FOR SAFETY: Before Leaving Or Servicing Machine; Stop On Level Surface, turn key switch OFF.**

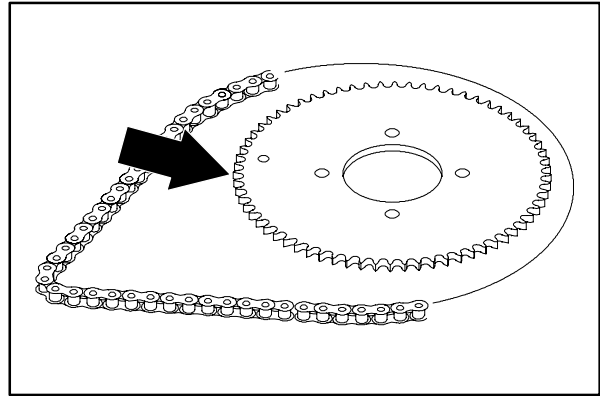

1. Remove the drive assembly from the machine. See TO REMOVE FRONT DRIVE ASSEMBLY instructions.

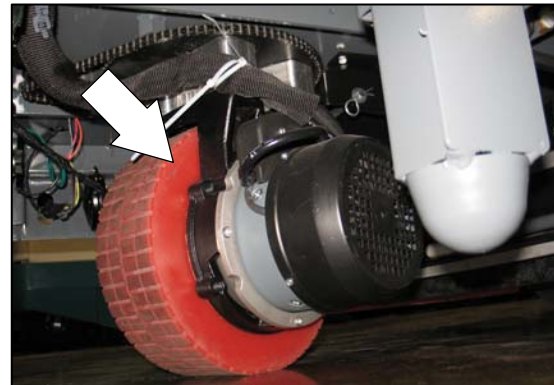

2. Remove the four hex screws holding the pivot and sprocket assembly to the drive assembly.
3. Remove the old sprocket from the pivot assembly.
4. Install the new sprocket on the pivot assembly.

*NOTE: Make sure the roll pin in the top of the drive assembly lines up with the hole in the sprocket.*

5. Reinstall the pivot and sprocket assembly on the drive assembly. Reinstall the four screws and tighten to 68 - 81 Nm (50 - 60 ft lb).
6. Reinstall the drive assembly in the machine. See TO INSTALL FRONT DRIVE ASSEMBLY instructions.
7. Operate the machine and check for smooth steering operation.

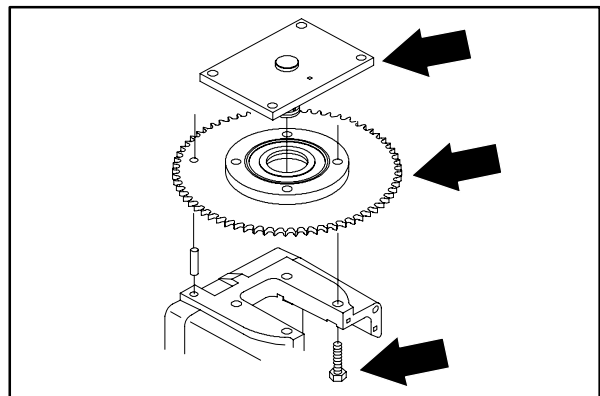

# T15 Maintenance & Repair

## TO REPLACE SMALL STEERING SPROCKET

**FOR SAFETY: Before Leaving Or Servicing Machine; Stop On Level Surface, turn key switch OFF.**

1. Raise the seat support and unplug the battery connectors.
2. Raise the front of the machine and place jack stands under the frame.

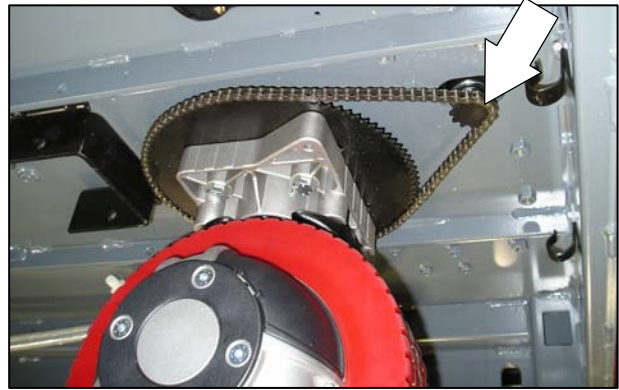

3. Go into the operators compartment and locate the lower steering shaft mount assembly. Loosen the two screws and pull the mount back to give the steering chain slack.

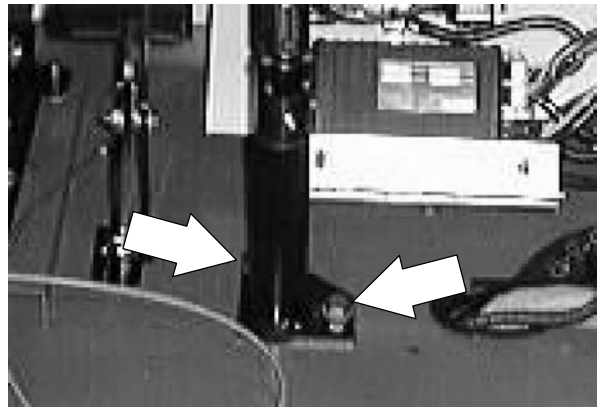

4. Go under the machine and locate the steering chain.

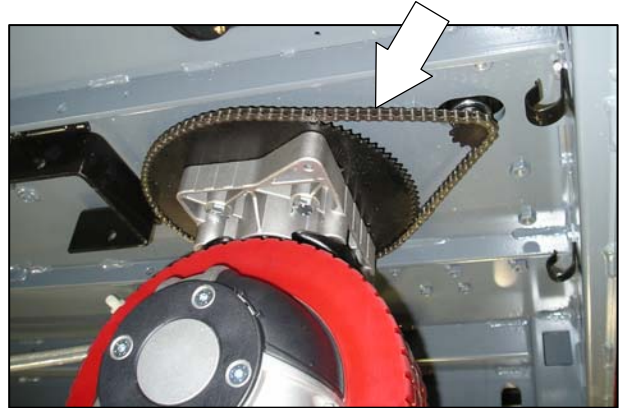

5. Rotate the steering wheel until the master link on the chain is accessible.
6. Remove the chain master link. Remove the steering chain from both sprockets.

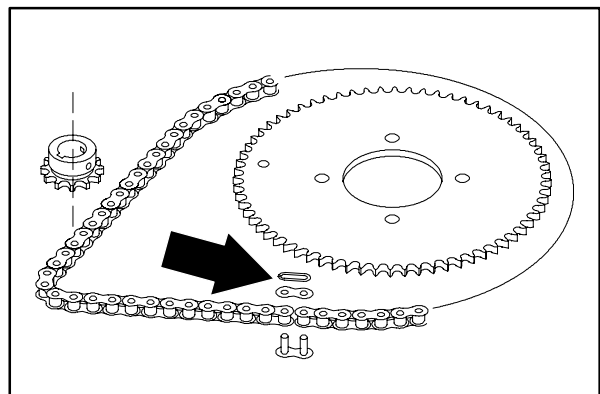

# T15 Maintenance & Repair

7. Loosen the set screws holding the small sprocket to the lower shaft. Slip the small sprocket off the shaft.

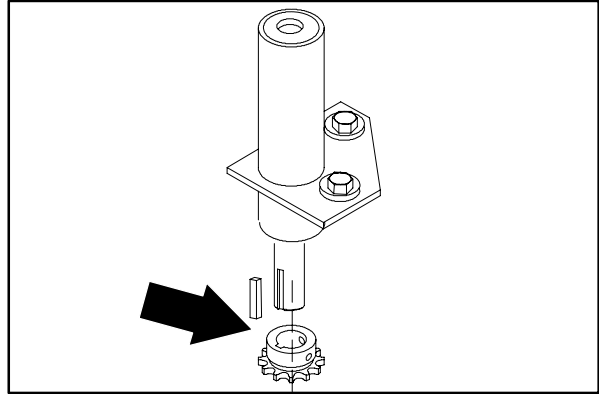

8. Install the new small sprocket on the lower steering shaft. Firmly tighten the set screws.

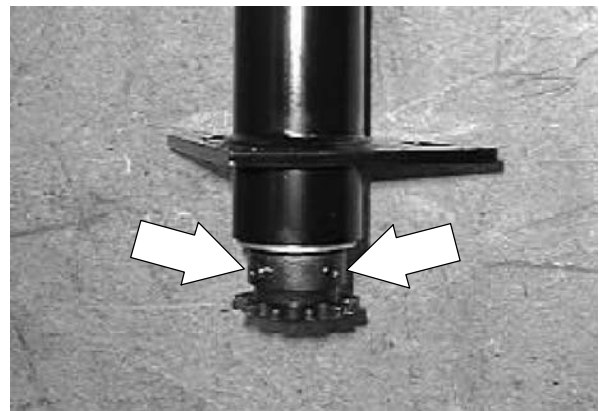

9. Route the steering chain around both steering sprockets. Install the master link.

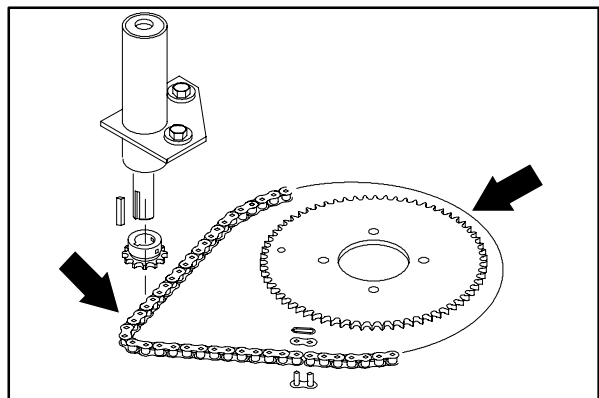

10. Adjust the steering chain. See TO ADJUST STEERING CHAIN instructions.

11. Remove the jack stands and lower the machine.

12. Operate the machine and check the steering for proper operation.

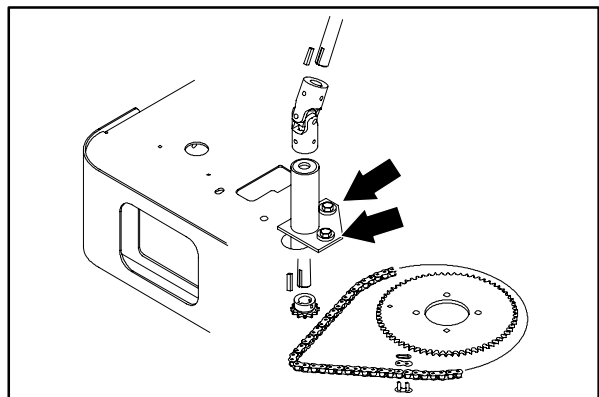

# T15 Maintenance & Repair

## TO REPLACE STEERING HOUSING BEARINGS

**FOR SAFETY: Before Leaving Or Servicing Machine; Stop On Level Surface, turn key switch OFF.**

1. Jack up the front of the machine at the jack point. Install jack stands under the machine frame.
2. Turn the steering wheel all the way to the left.
3. Go to the operators compartment and locate the steering U-joint. Loosen the two set screws on the top of the steering U-joint.

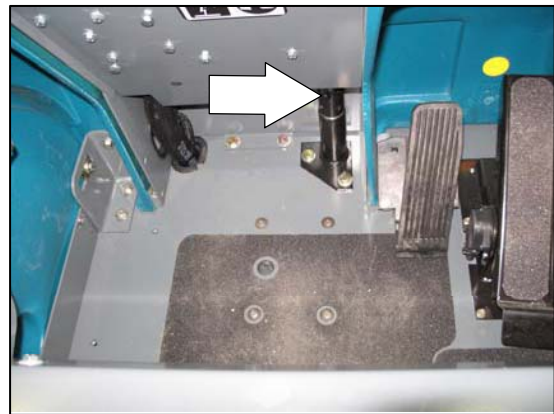
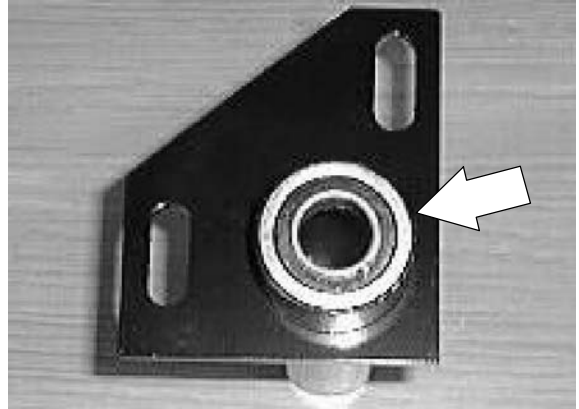

4. Pull the steering wheel and long steering shaft up and out of the top of the steering U-joint.

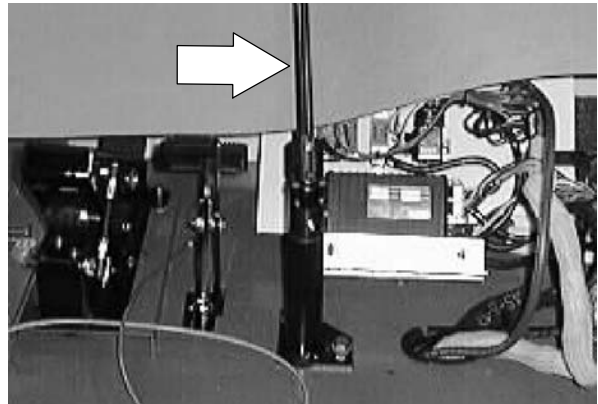

5. Remove the two hex screws holding the steering bearing housing to the machine frame. Push the bearing housing back in the slots.



# T15 Maintenance & Repair

6. Go under the machine and locate the small steering chain sprocket.

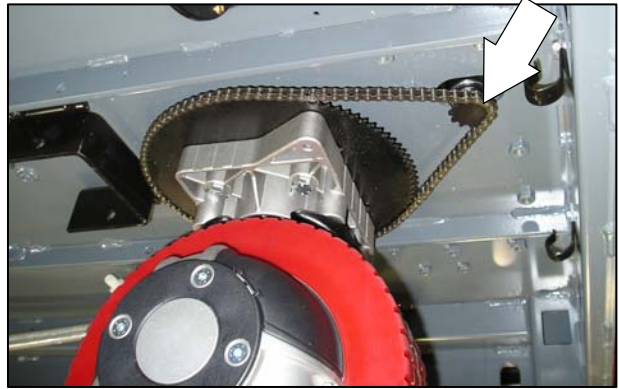

7. Locate the master link on the steering chain. Remove the master link and steering chain from the small steering sprocket.

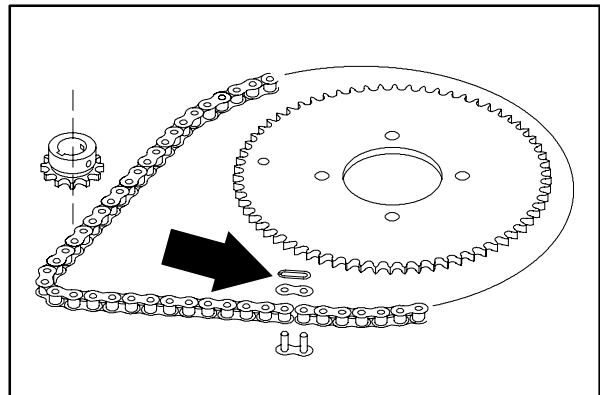

8. Remove the steering housing from the machine.

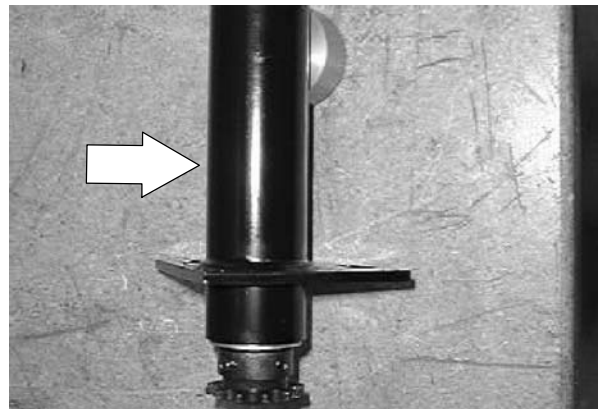

9. Loosen the two set screws holding the U-joint to the top of the short steering shaft. Remove and retain the U-joint and square key.

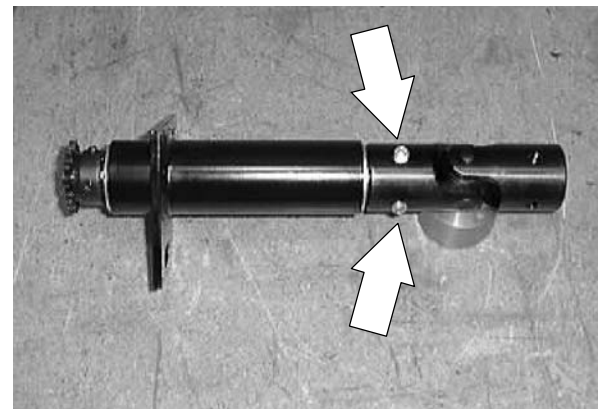

# T15 Maintenance & Repair

10. Loosen the set screw holding the small steering sprocket to the bottom of the short steering shaft. Remove and retain small sprocket and woodruff key.

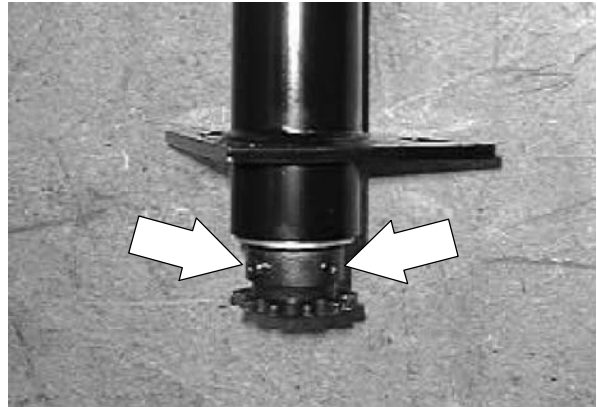

11. Use an arbor press to press the short steering shaft and two bearings out of the housing. Discard the bearings. Retain the short shaft.

*NOTE: Note the orientation of the shaft in the housing.*

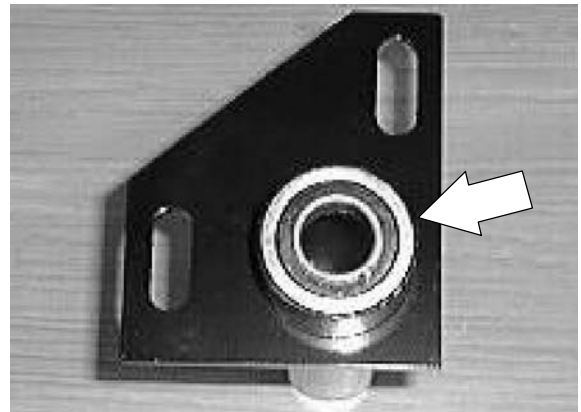

12. Use the arbor press to install the new bearings into the steering housing.

13. Use the arbor press to install the short steering shaft into the new bearings.



14. Reinstall the small steering sprocket and woodruff key on the bottom of the steering housing. Tighten the set screws tight.

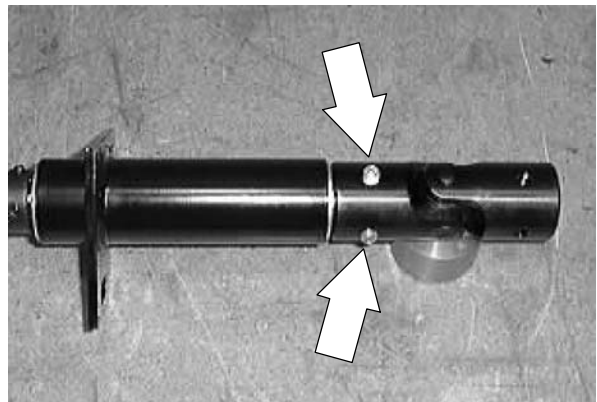

15. Reinstall the U-joint and square key on the top of the steering housing. Tighten the set screws tight.

M



# T15 Maintenance & Repair

16. Reinstall the steering housing in the machine. Reinstall the two hex screws. Leave loose for now.

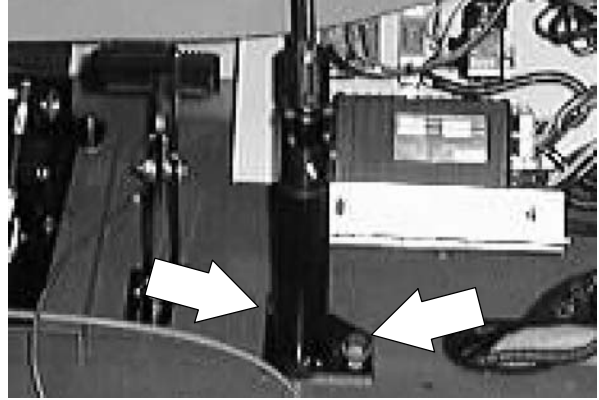

17. Position the long steering shaft and steering wheel into the top of the steering U-joint. Tighten the set screws tight.

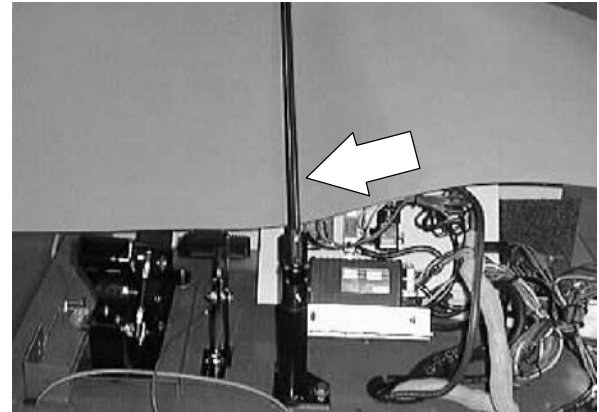

18. Go under the machine and reinstall the steering chain around the small steering sprocket. Reinstall the master link.

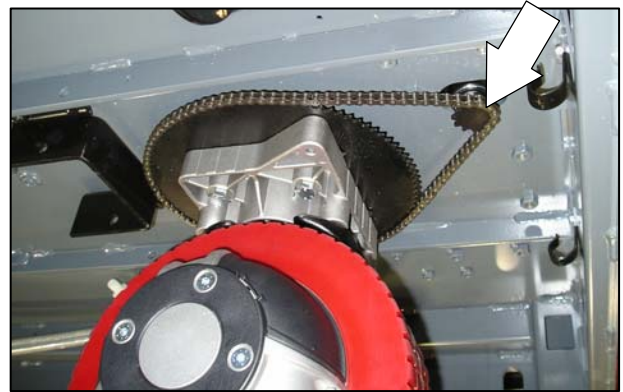

19. Turn the steering wheel all the way to the left and then to the right. Find the point in the rotation where the steering chain is the most tight.

20. Push the bearing housing forward in the slots. This will remove any excess slack in the steering chain. Tighten the two hex screws to 37 - 48 Nm (26 - 34 ft lb).

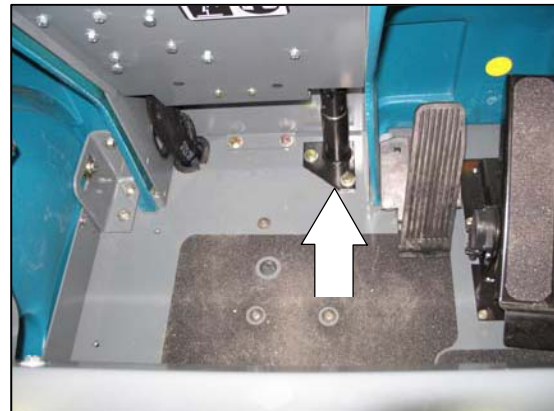

21. Remove the jack stands and lower the machine to the floor. Operate the machine and check the steering chain for proper operation.



# T15 Maintenance & Repair

## TO REPLACE STEERING U-JOINT

**FOR SAFETY: Before Leaving Or Servicing Machine; Stop On Level Surface, turn key switch OFF.**

1. Jack up the front of the machine at the jack point. Install jack stands under the machine frame.
2. Go to the operators compartment and locate the steering U-joint. Loosen the two set screws on the top of the steering U-joint.

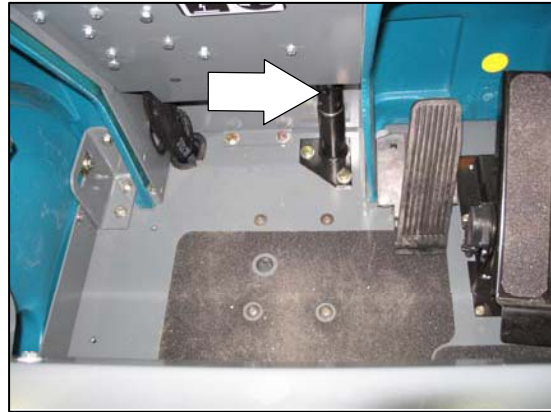

3. Pull the steering wheel and long steering shaft up and out of the top of the steering U-joint.

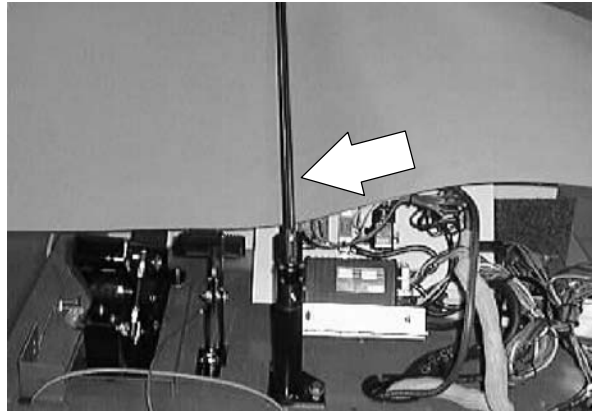

4. Loosen the two set screws holding the U-joint to the top of the short steering shaft. Remove and discard the U-joint and square key.

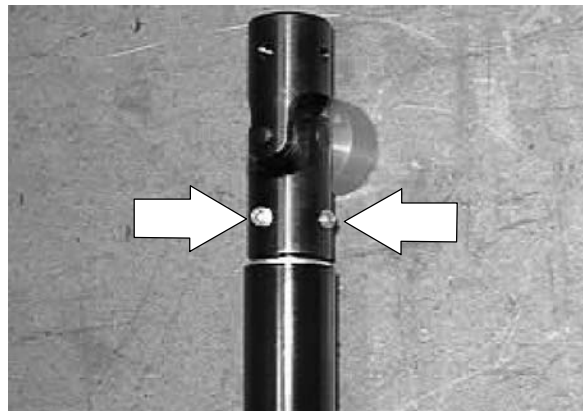

M

## T15 Maintenance & Repair

5. Install the new U-joint and square key on the top of the steering housing. Tighten the set screws tight.

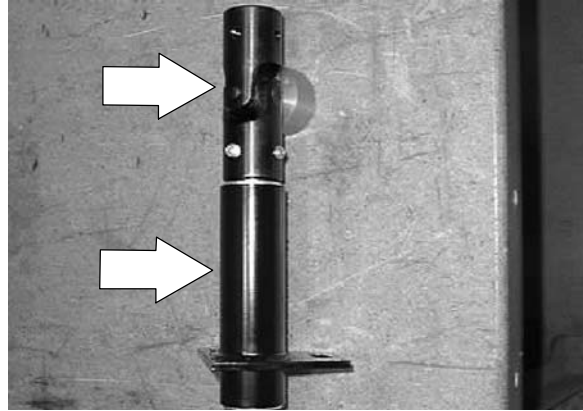

6. Position the long steering shaft and steering wheel into the top of the steering U-joint. Tighten the set screws tight.

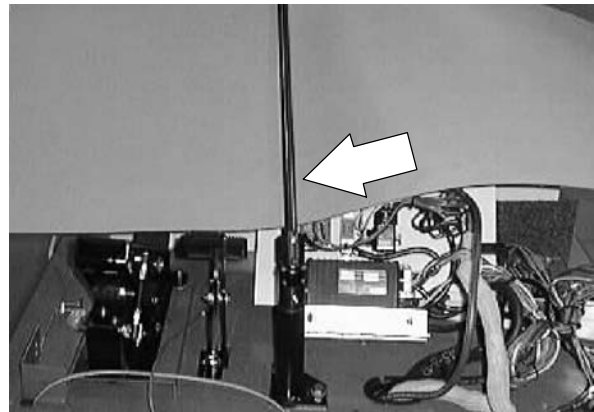

7. Operate the machine and check the steering U-joint for proper operation.



# T15 Maintenance & Repair

---

## SEAT

---

### OPERATOR SEAT

The standard operators seat is a fixed back style. The seat can be adjusted forward and backward. The operator seat is equipped with a switch that prevents the machine from propelling unless someone is sitting on it.

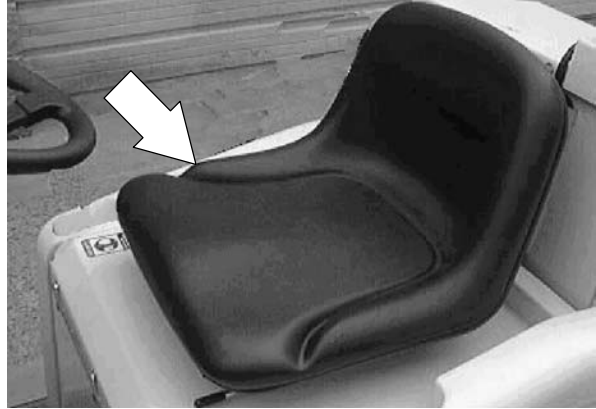

### TO REMOVE SEAT ASSEMBLY

**FOR SAFETY: Before Leaving Or Servicing Machine; Stop On Level Surface, turn key switch OFF.**

1. Lift the seat assembly until the prop rod is engaged.

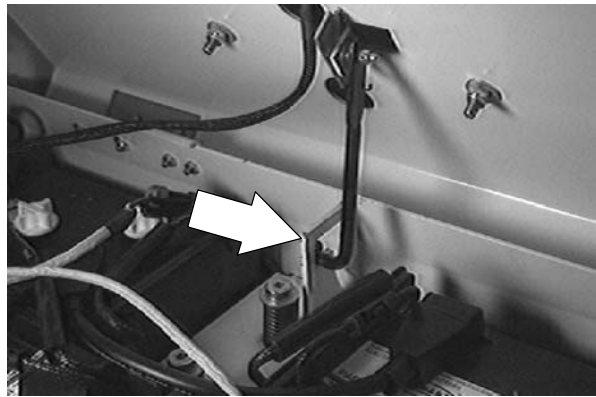

2. Unplug the seat switch wire harness plug from the main harness.

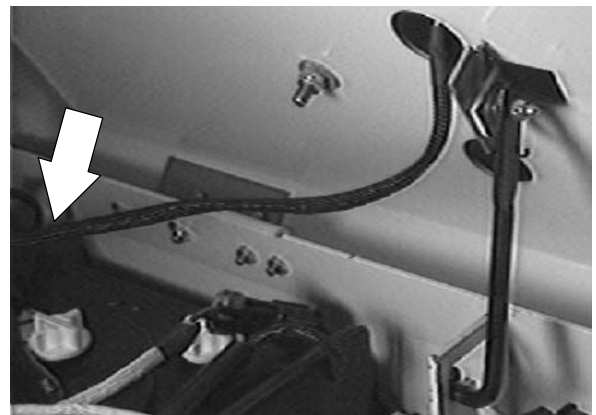

## T15 Maintenance & Repair

3. Lift the seat assembly slightly and remove the prop rod from the slot in the prop rod bracket.

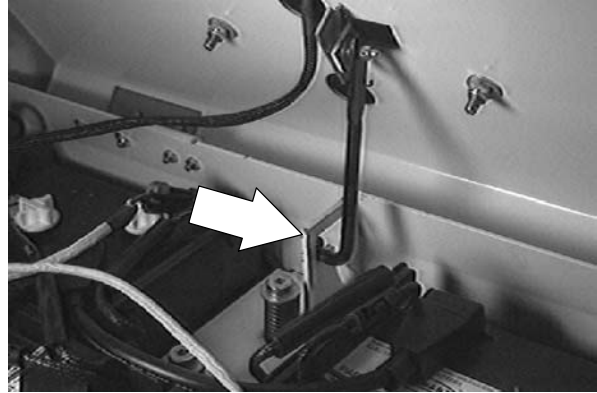

4. Slide the seat assembly to the right until it is off the two mount pins. Remove the seat assembly from the machine.

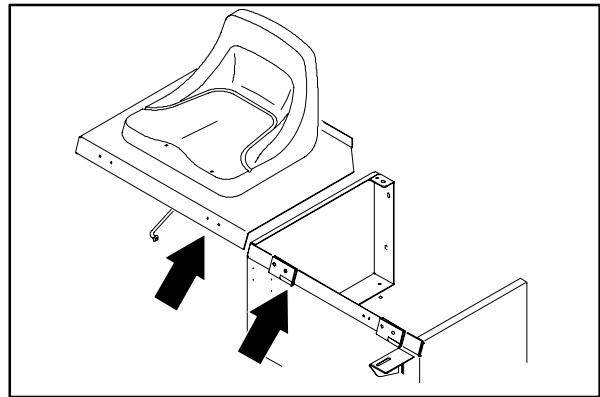

# T15 Maintenance & Repair

## TO INSTALL SEAT ASSEMBLY

**FOR SAFETY: Before Leaving Or Servicing Machine; Stop On Level Surface, turn key switch OFF.**

1. Position the seat assembly in the operators compartment.
2. Line up the two hinge pins on the seat assembly and seat support. Slide the seat assembly all the way on the pins.

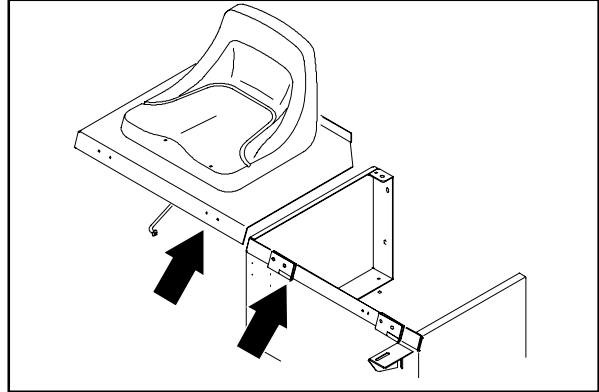

3. Install the prop rod in the bracket slot.

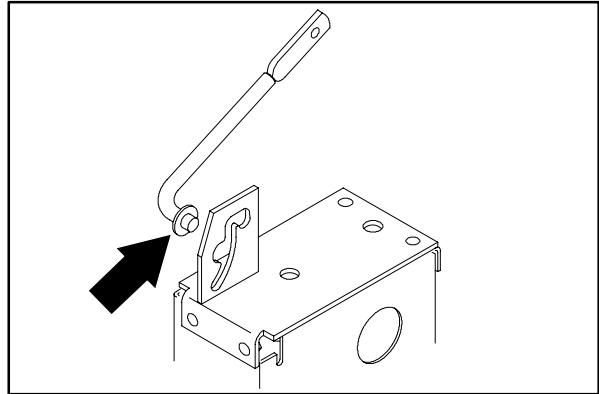

4. Route the seat switch harness through the hole in the seat support plate.

5. Plug the seat switch harness into the main harness plug.

6. Disengage the prop rod and lower the seat assembly.

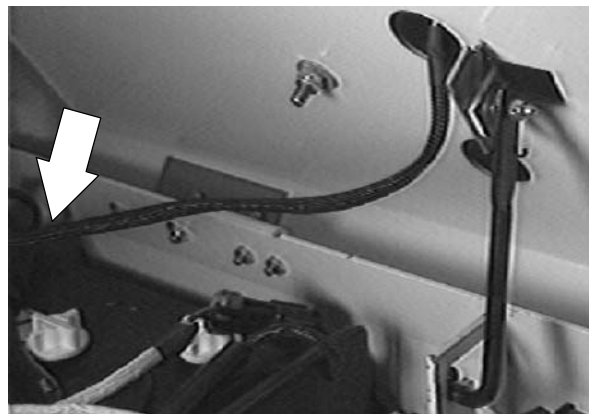

# T15 Maintenance & Repair

## TO ADJUST SEAT POSITION

**FOR SAFETY: Before Leaving Or Servicing Machine; Stop On Level Surface, turn key switch OFF.**

1. Sit down on the seat in the operators compartment.
2. Grasp the adjustment lever in the front center of the seat.
3. Push the adjustment lever to the left.
4. Move the seat forward or backward until the desired position is achieved.
5. Release the adjustment lever. The seat will now be locked in the new position.

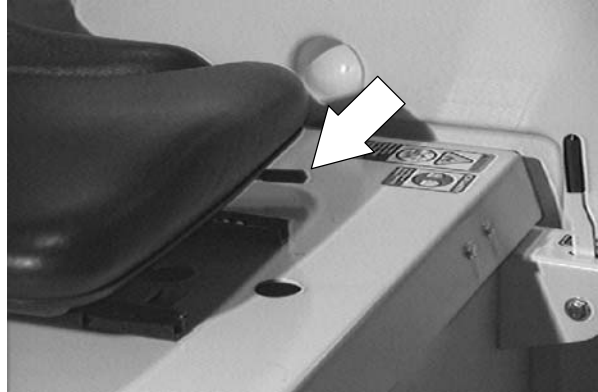

# T15 Maintenance & Repair

---

## PUSHING, TOWING, AND TRANSPORTING THE MACHINE

---

### PUSHING OR TOWING THE MACHINE

If the machine becomes disabled, it can be pushed or towed from the front or rear.

The parking brake must be disabled before towing or pushing the machine. To disable the brake, pull the brake release lever to the guard and use a cable tie to secure the lever to the guard. The machine can move freely when the parking brake is disabled.

Only push or tow the machine for a *very short distance* and do not exceed 3.2 kp/h (2 mph). It is NOT intended to be pushed or towed for a long distance or at a high speed.

**ATTENTION! Do not push or tow machine for a long distance or damage may occur to the propelling system.**

Immediately after pushing the machine, remove the cable tie to enable the parking brake. Never operate the machine with the parking brake disabled.

**FOR SAFETY: Do not operate machine with brake disabled.**

### TRANSPORTING THE MACHINE

1. Position the rear of the machine at the loading edge of the truck or trailer.

**FOR SAFETY: Use truck or trailer that will support the weight of the machine.**

*NOTE: Empty the recovery and solution tanks before transporting the machine.*

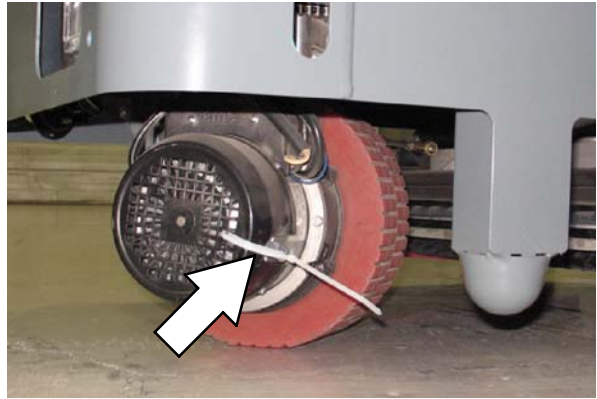



# T15 Maintenance & Repair

2. If the loading surface is not horizontal or is higher than 380 mm (15 in) from the ground, use a winch to load machine.

If the loading surface is horizontal AND is 380 mm (15 in) or less from the ground, the machine may be driven onto the truck or trailer.

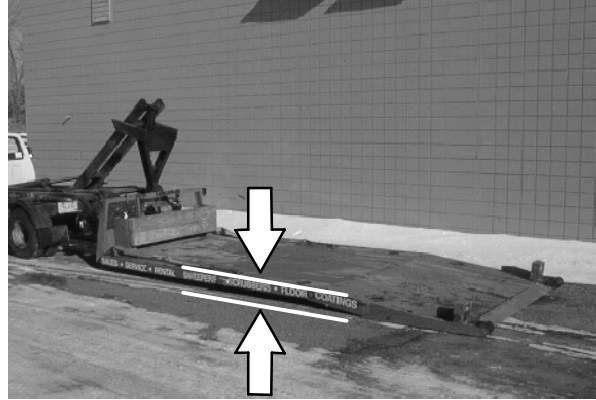

3. To winch the machine onto the truck or trailer, attach the winching chains to the rear tie down locations. The rear tie-down locations are the holes in the sides of the machine frame near the rear bumper.

**FOR SAFETY: When loading machine onto truck or trailer, use winch. Do not drive the machine onto the truck or trailer unless the loading surface is horizontal AND is 380 mm (15 in) or less from the ground.**

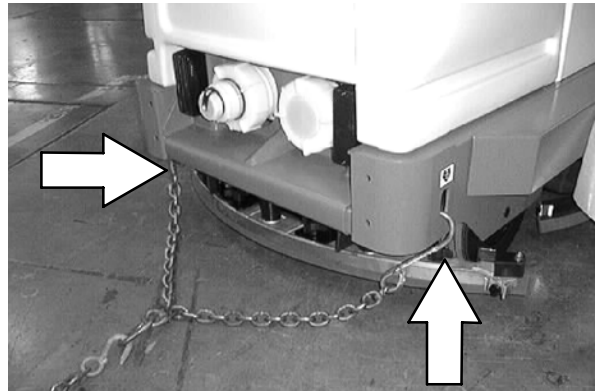

4. Position the machine onto the truck or trailer as far as possible. If the machine starts to veer off the center line of the truck or trailer, stop and turn the steering wheel to center the machine.
5. Lower the scrub head and block the machine tires. Tie down the machine to the truck or trailer before transporting.

The front tie-down locations are the holes in the front side of the machine frame.

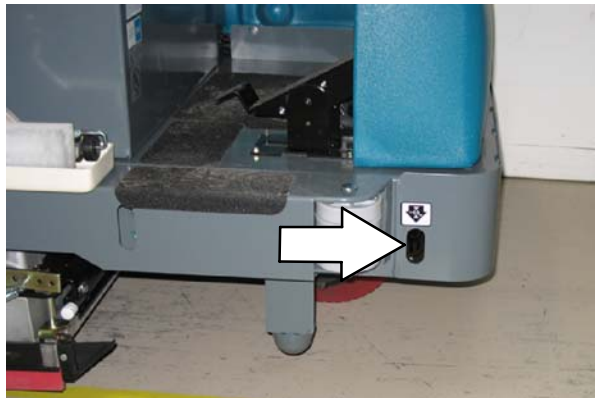

# T15 Maintenance & Repair

The rear tie-down locations are the holes in the sides of the machine frame near the rear bumper.

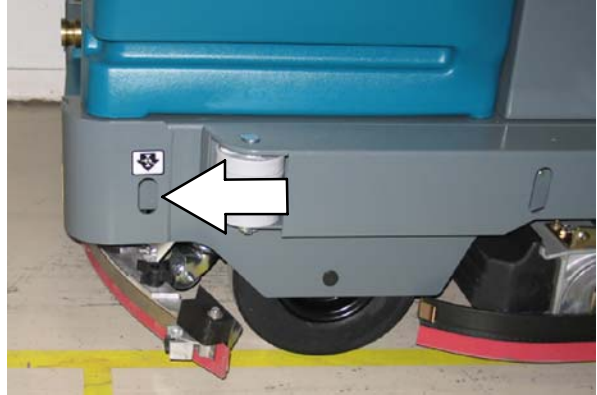

6. If the loading surface is not horizontal or is higher than 380 mm (15 in) from the ground, use a winch to unload machine.

If the loading surface is horizontal AND is 380 mm (15 in) or less from the ground, the machine may be driven off the truck or trailer.

**FOR SAFETY: When unloading machine off truck or trailer, use winch. Do not drive the machine off the truck or trailer unless the loading surface is horizontal AND 380 mm (15 in) or less from the ground.**

---

## MACHINE JACKING

---

Empty the recovery solution tanks before jacking the machine. Jack up the machine from underneath all four corners of the machine. Use a hoist or jack that will support the weight of the machine. Use a piece of wood between the jack and frame to distribute the machine weight load.

Always stop the machine on a flat level surface and block the tires before jacking the machine up.

**FOR SAFETY: When servicing machine, block machine tires before jacking machine up.**

**FOR SAFETY: When servicing machine, jack machine up at designated locations only. Block machine up with jack stands.**

# T15 Maintenance & Repair

---

## STORAGE INFORMATION

---

The following steps should be taken when storing the machine for extended periods of time.

1. Drain and clean the solution and recovery tanks.  
  
ES machines: Run clean water through the solution system and the ES solution pump.
2. Park the machine in a cool, dry area.
3. Remove the batteries, or charge them every three months.

## FREEZE PROTECTION

1. Be sure the solution tank is empty.
2. Pour 3.8 L (1 gal) of RV antifreeze into the solution tank.
3. Turn the machine power on.
4. Start the solution flow. Start the power wand solution system and ES system to circulate the antifreeze through the components.
5. The antifreeze does not need to be drained from the solution tank.

*NOTE: Storing or transporting machines equipped with the ES or FaST system in freezing temperatures requires special procedures. Consult a TENNANT representative for more information.*







# T15

# ELECTRICAL

## Troubleshooting Information

### BEFORE CONDUCTING TESTS:

- \* Read and Follow ALL Safety Warnings and Precautions as mentioned at the beginning of this manual
- \* Always use an ESD (Electrostatic Discharge) strap when working near the Control Board
- \* Be cautious when working near Control Board – Battery voltage is always present, even with Key OFF
- \* Always unhook Battery when removing or replacing components

### DURING TESTS:

- \* Call Technical Services if Diagnostic Time Exceeds One Hour With Unknown Cause or Course of Action

**NOTE:** Troubleshooting charts may be shown with optional equipment. The optional equipment may not be specified in these charts. Some machines may not be equipped with all components shown.



# T15 Electrical Schematic

(Page 1 of 3)

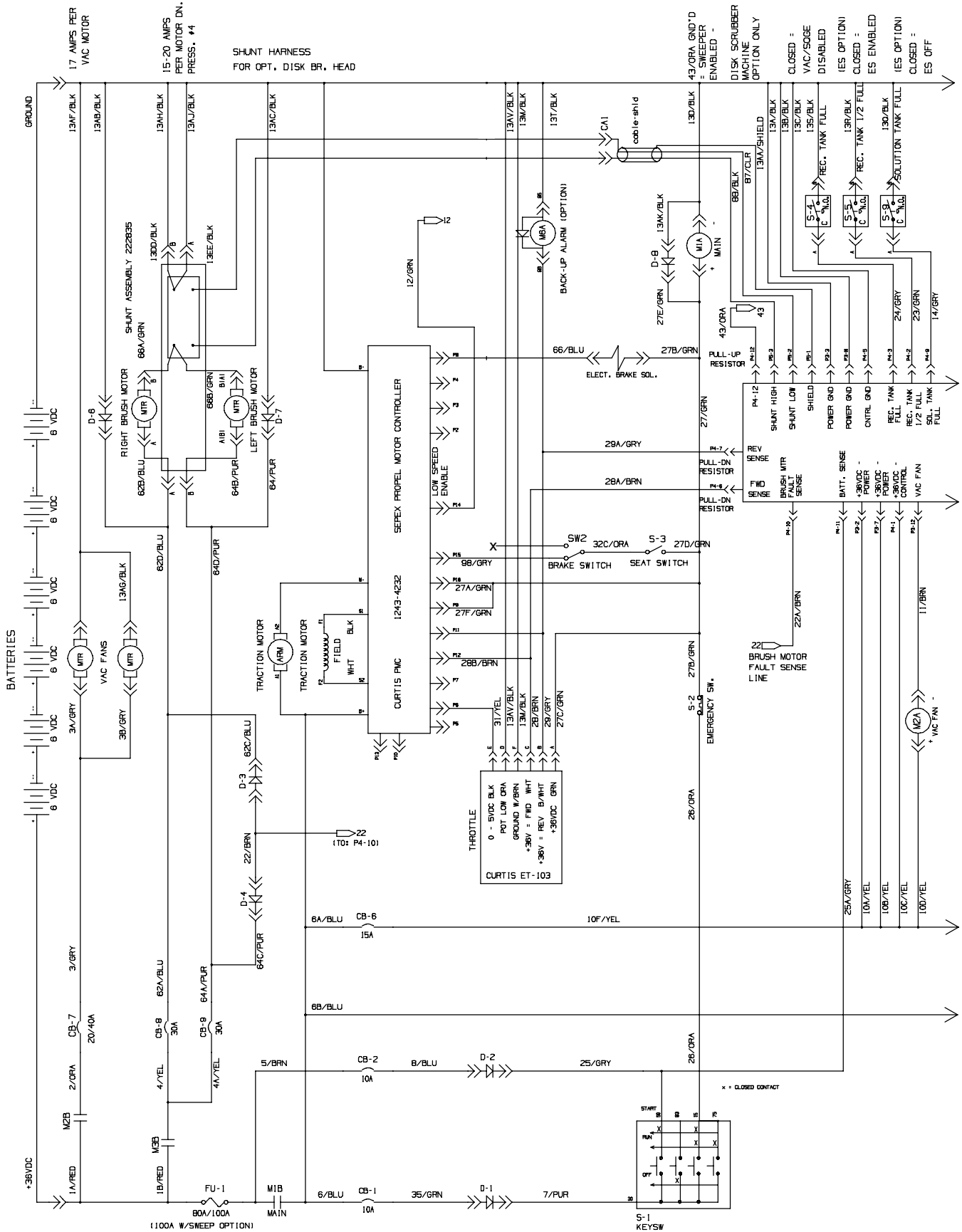

1037934

# T15 Electrical Schematic

(Page 2 of 3)

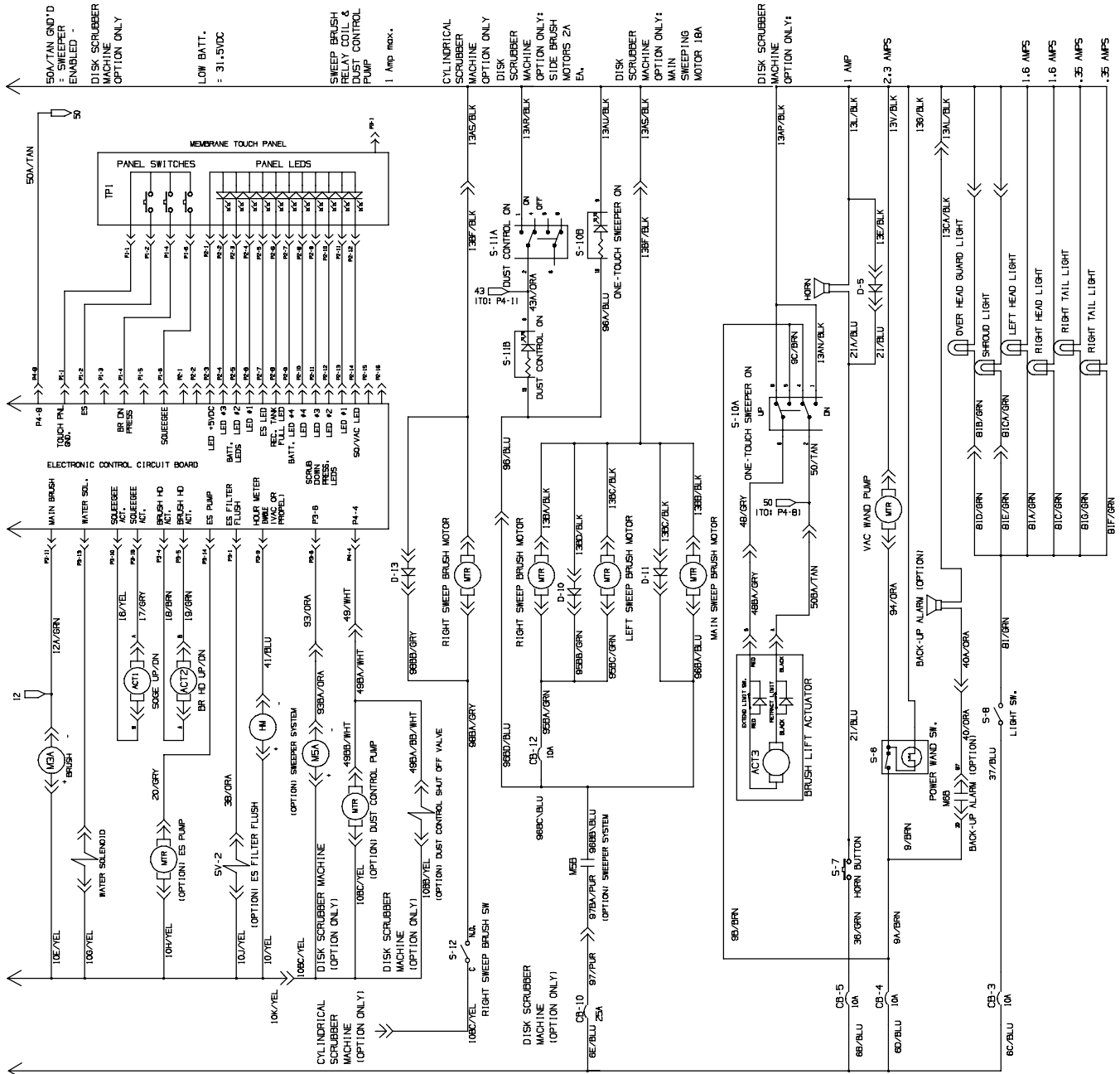

# T15 Electrical Schematic

(Page 3 of 3)

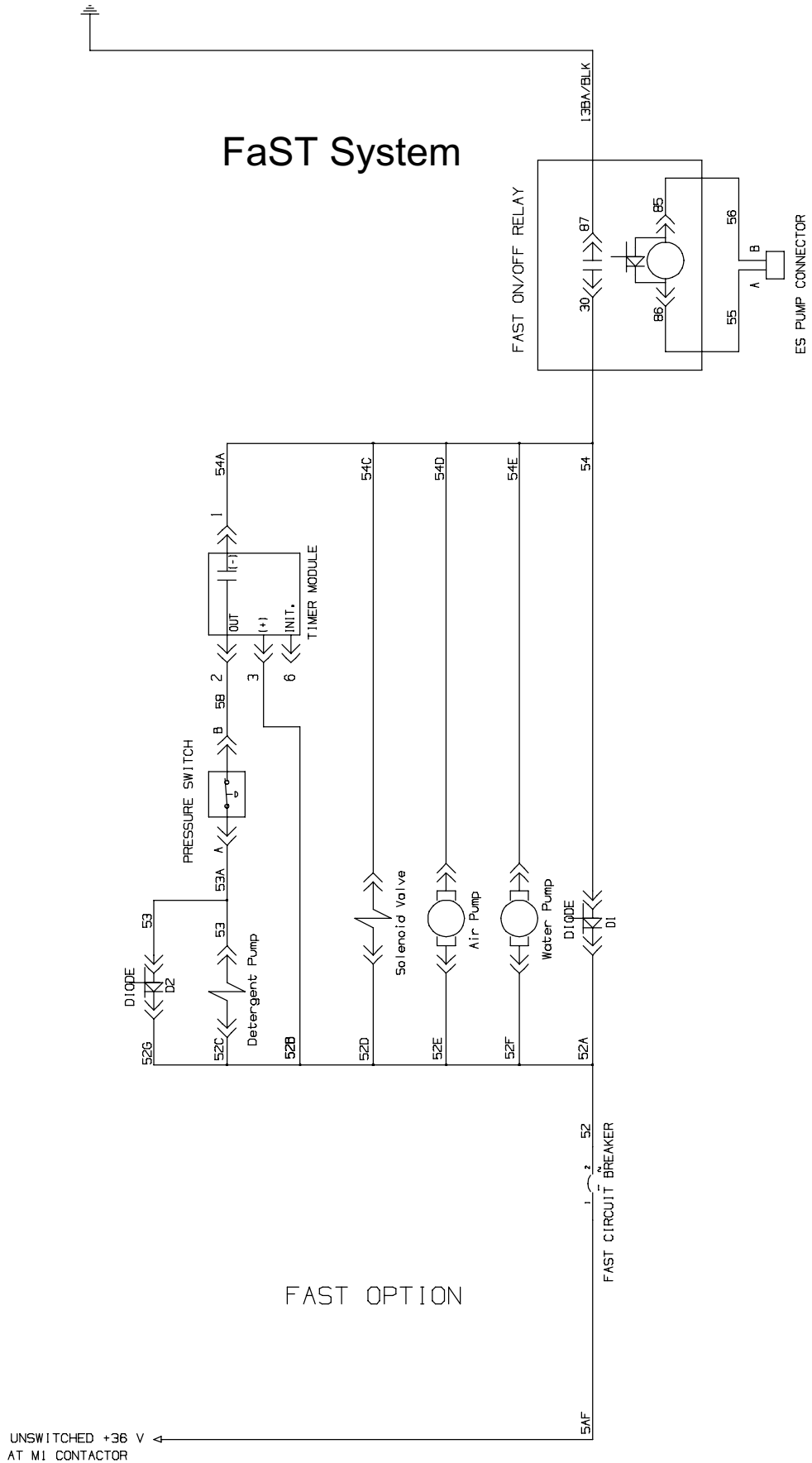

UNSWITCHED +36 V  
AT M1 CONTACTOR

1037934



# T15 Harness Drawings

(Page 1 of 8)

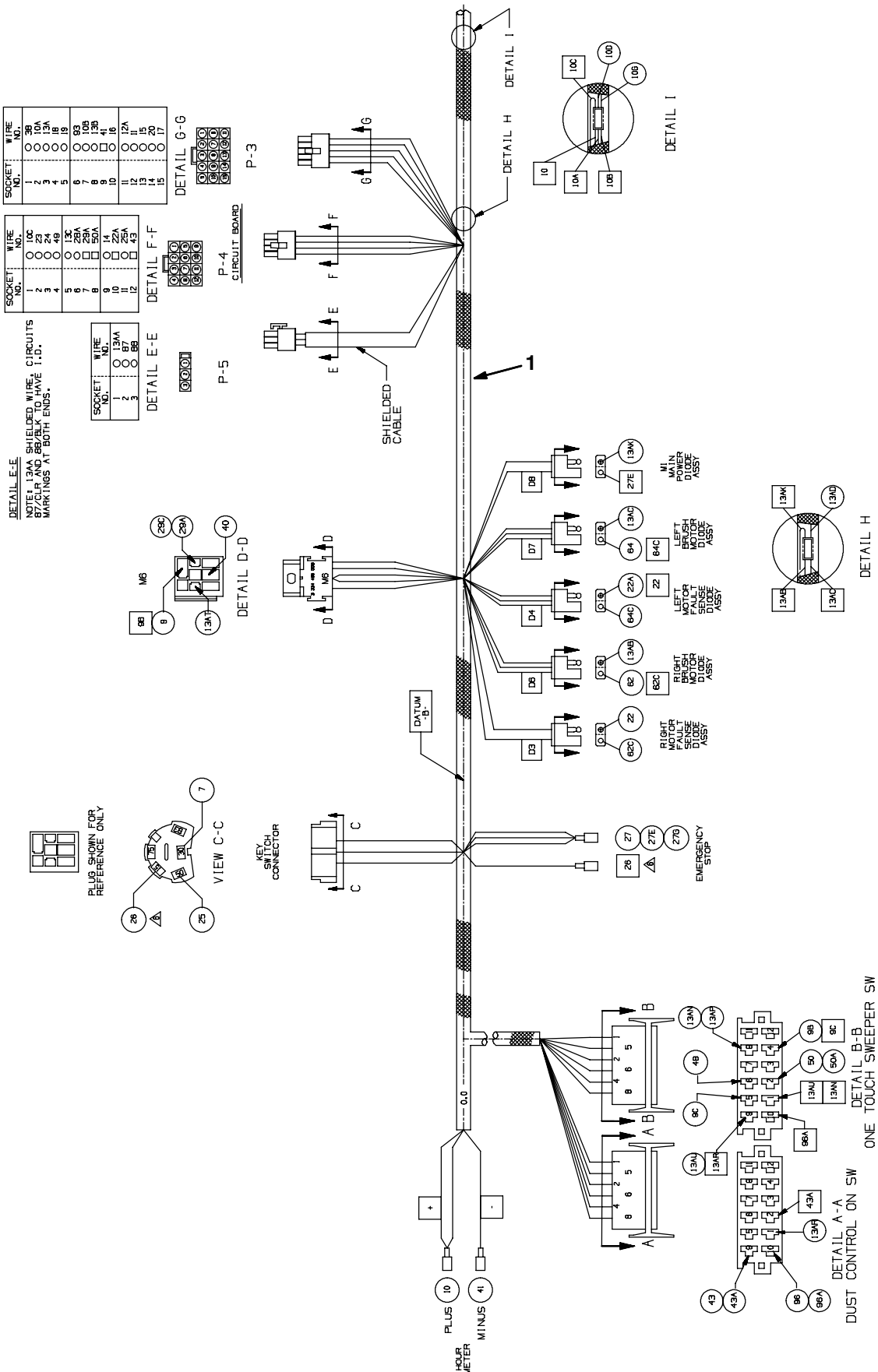

DETAIL E-E

NOTE: 13A SHIELDED WIRE CIRCUITS SHALL ONLY HAVE 1.0 MARKINGS AT BOTH ENDS.

SOCKET NO.	WIRE NO.
1	3B
2	13A
3	18
4	18
5	18
6	9B
7	13B
8	13B
9	41
10	6
11	12A
12	15
13	15
14	15
15	17

DETAIL F-F

SOCKET NO.	WIRE NO.
1	10C
2	22A
3	49
4	49
5	13C
6	28A
7	50A
8	50A
9	14
10	22A
11	43A
12	43A

DETAIL E-E

SOCKET NO.	WIRE NO.
1	13M
2	6B
3	6B

DETAIL G-G

SOCKET NO.	WIRE NO.
1	10C
2	22A
3	49
4	49
5	13C
6	28A
7	50A
8	50A
9	14
10	22A
11	43A
12	43A

DETAIL F-F

SOCKET NO.	WIRE NO.
1	10C
2	22A
3	49
4	49
5	13C
6	28A
7	50A
8	50A
9	14
10	22A
11	43A
12	43A

DETAIL E-E

SOCKET NO.	WIRE NO.
1	13M
2	6B
3	6B

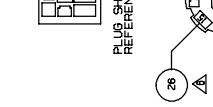
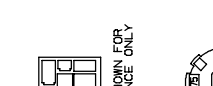
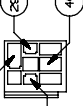
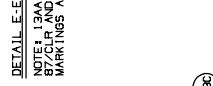

# T15 Harness Drawings

(Page 2 of 8)

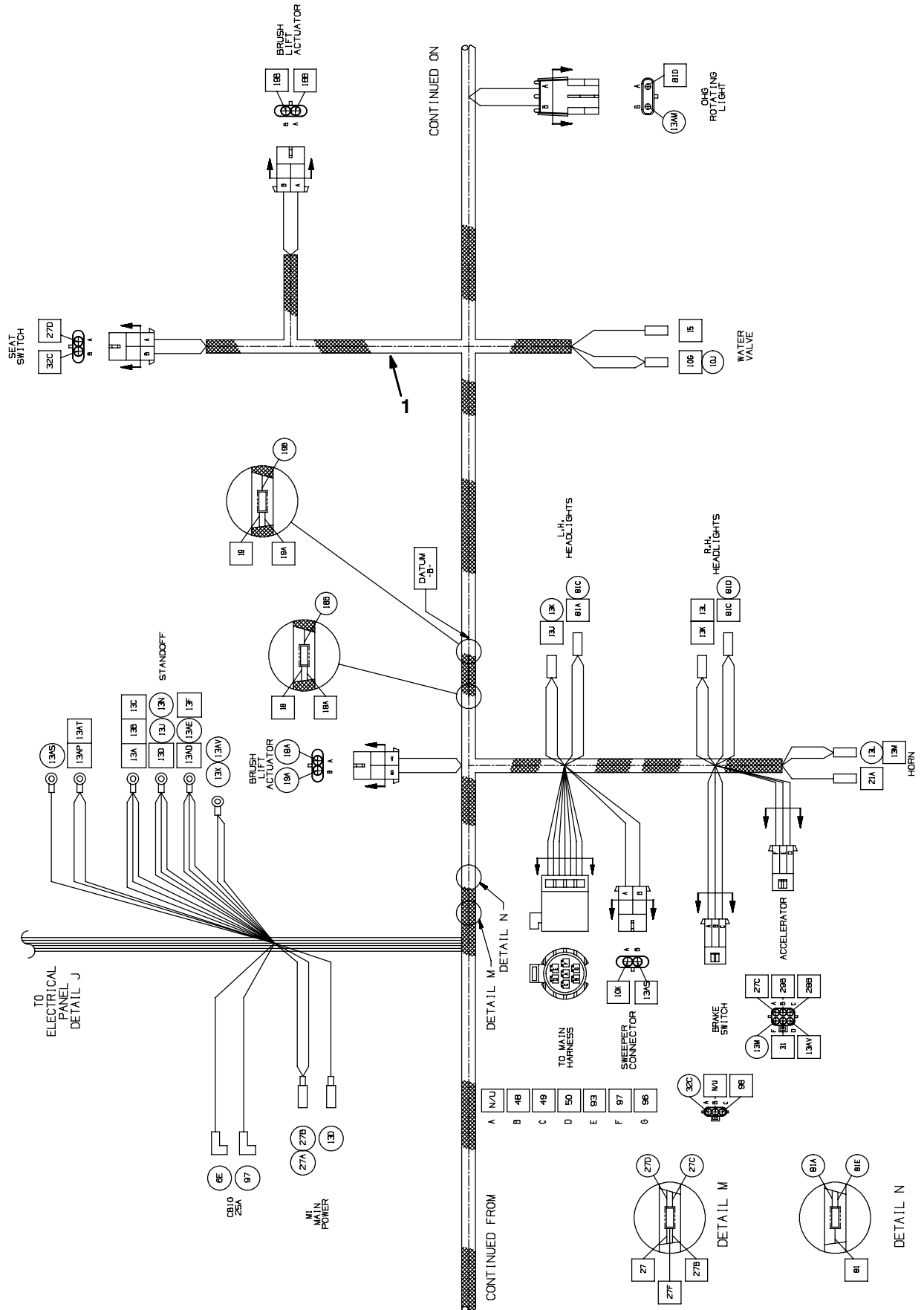

# T15 Harness Drawings

(Page 3 of 8)

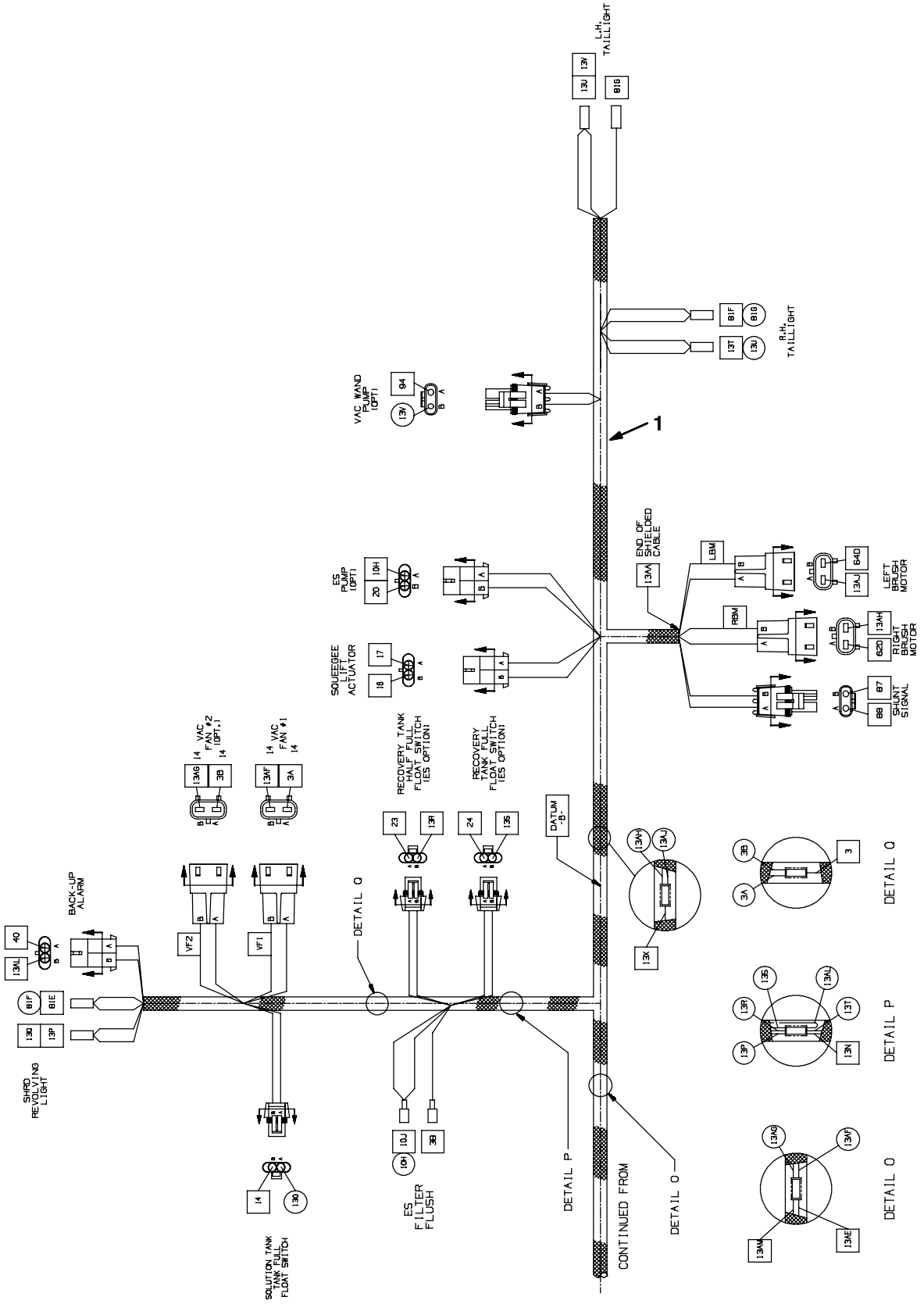

# T15 Harness Drawings

(Page 4 of 8)

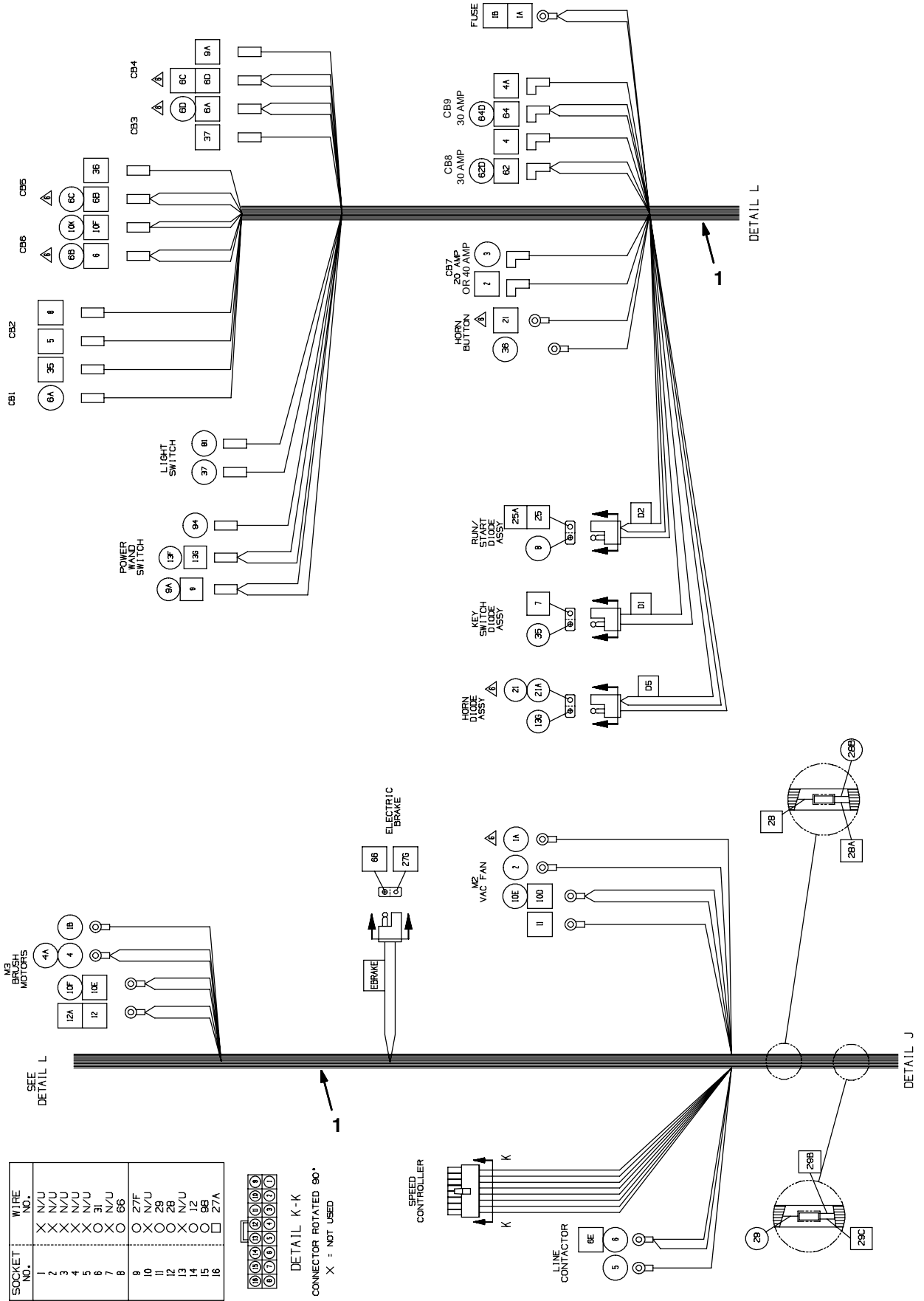

# T15 Harness Drawings

(Page 5 of 8)

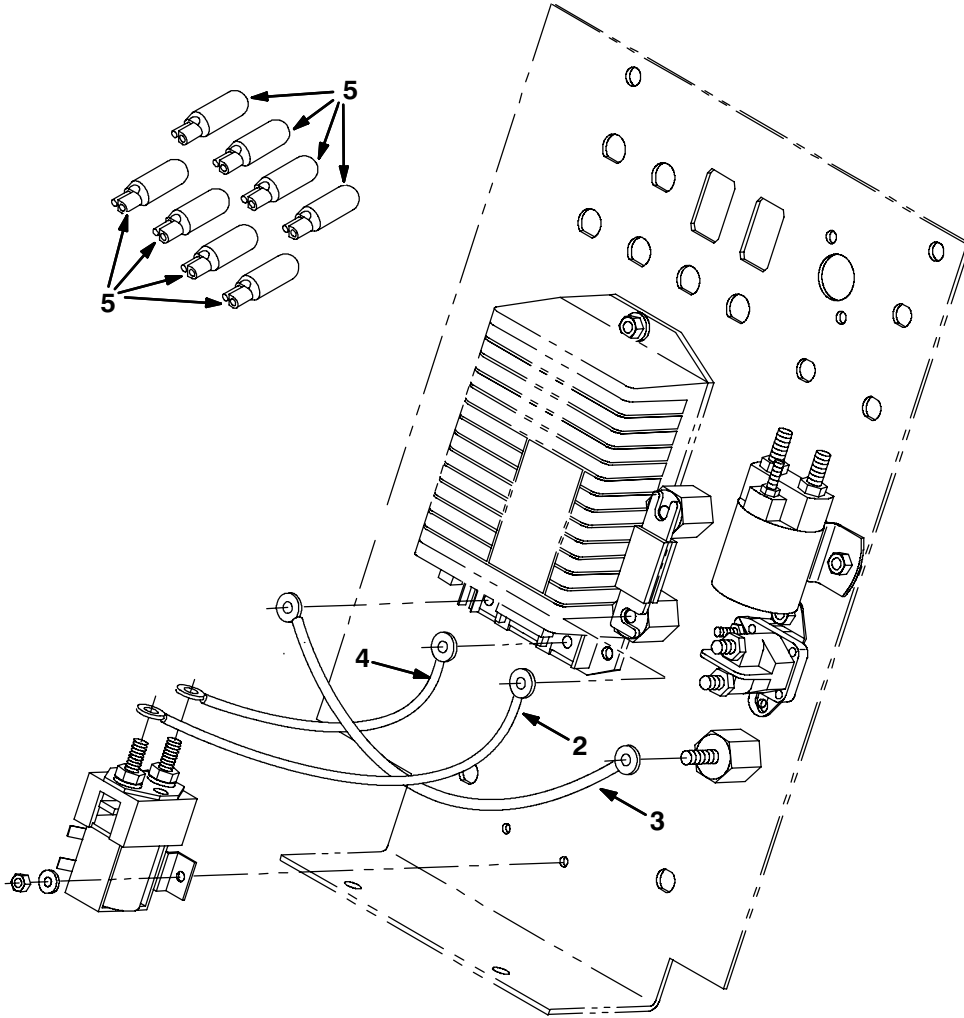

354542, 354548

Ref.	Serial Number	Description	Qty.
1	(000000- )	Harness, Main [T15]	1
2	(000000- )	Cable, 06ga 07.0l Blk .28ring /.34ring	1
3	(000000- )	Cable, 06ga 11.0l Blk .28ring /.34ring	1
4	(000000- )	Cable, 06ga 07.0l Blk .34ring /.34ring	1
5	(000000- )	Diode, Ele, Plug	8



# T15 Harness Drawings

(Page 6 of 8)

## FaST Harness

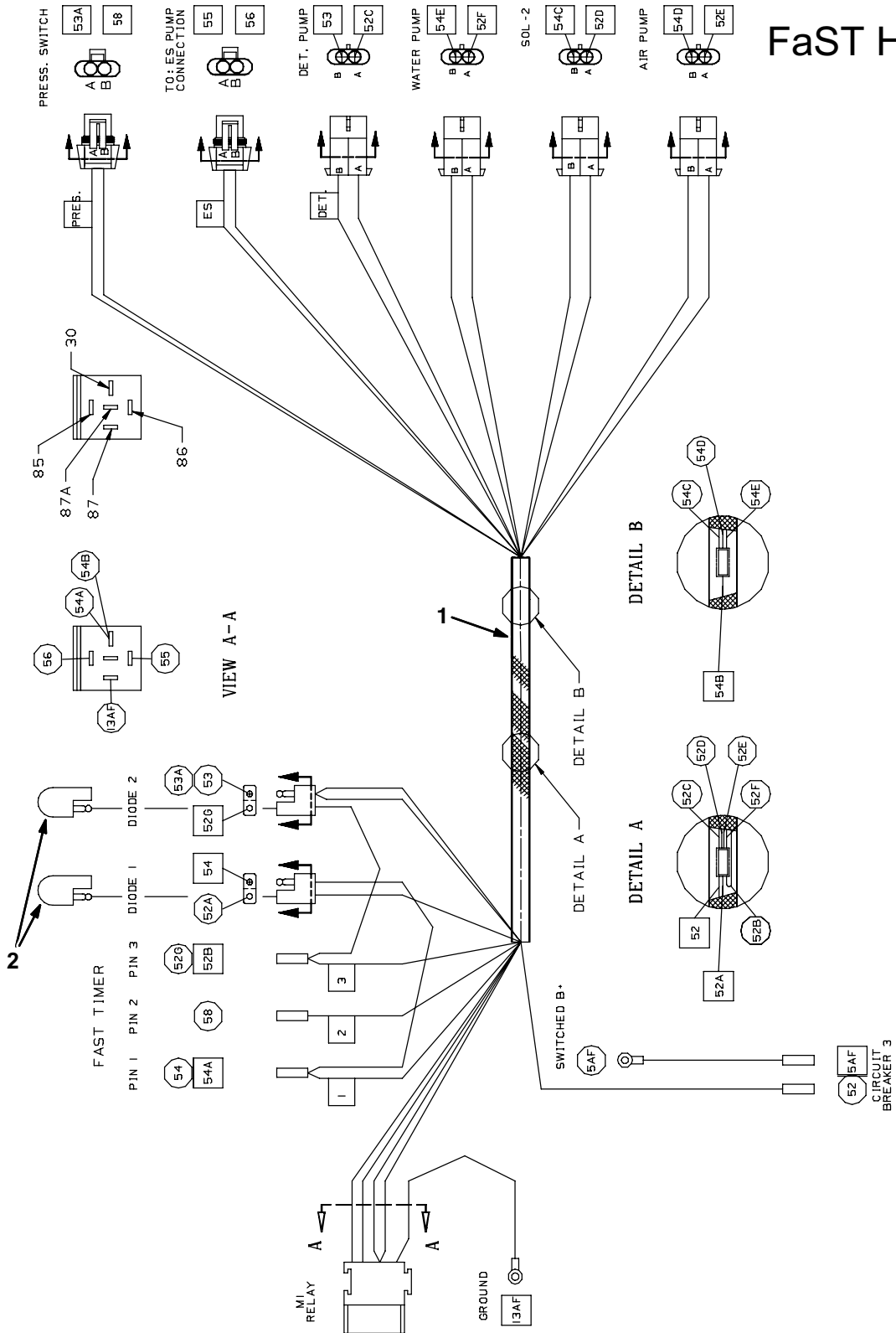

354214

Ref.	Serial Number	Description	Qty.
1	(000000- )	Harness	1
2	(000000- )	Diode, Ele, Plug	2

# T15 Harness Drawings

(Page 7 of 8)

## Pre-Sweep Wire Harness

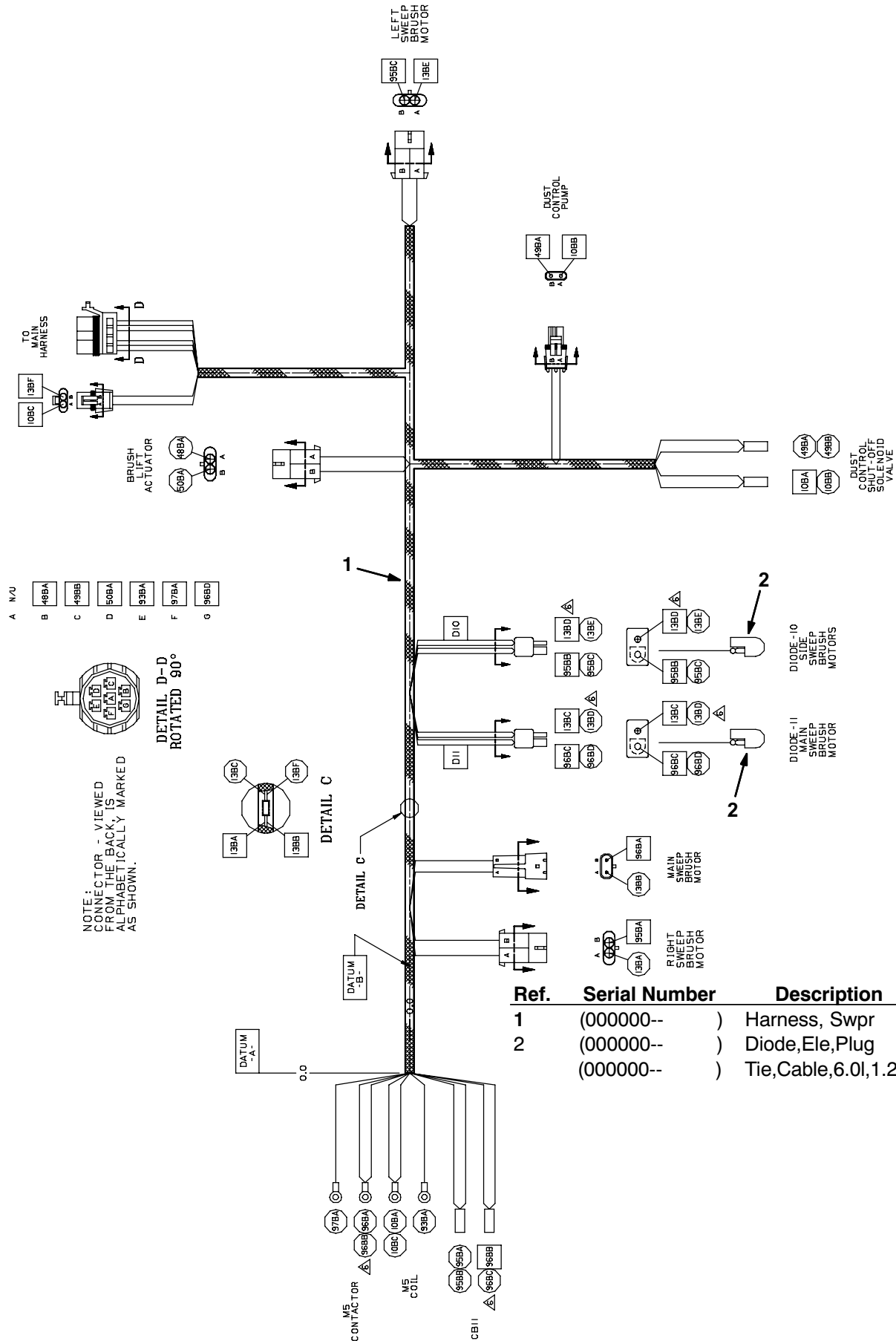

Ref.	Serial Number	Description	Qty.
1	(000000-- )	Harness, Swpr	1
2	(000000-- )	Diode,Ele,Plug	2
	(000000-- )	Tie,Cable,6.0l,1.25d	3

# T15 Harness Drawings

(Page 8 of 8)

## Side Brush Wire Harness

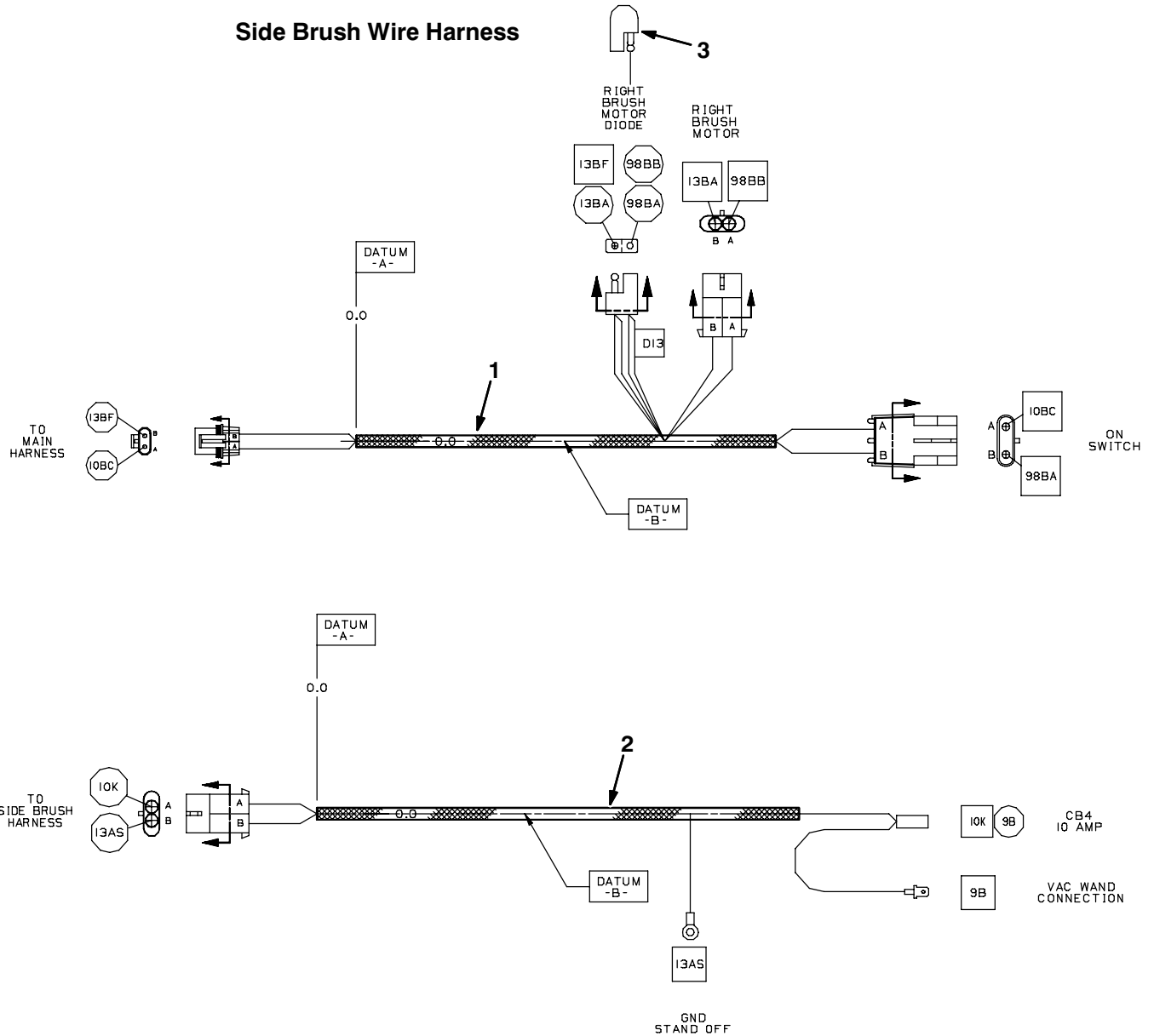

353425 - NA

Ref.	Serial Number	Description	Qty.
1	(000000- )	Harness, Sba, Rh	1
2	(000000- )	Harness, Sba, Retrofit	1
3	(000000- )	Diode, Ele, Plug	1
	(000000- )	Tie, Cable, 6.0l, 1.25d Max	4



# Commonly Used Electrical Symbols & Terms

NOTE: The term "NORMALLY" refers to the component's "at rest" or "de-energized" position

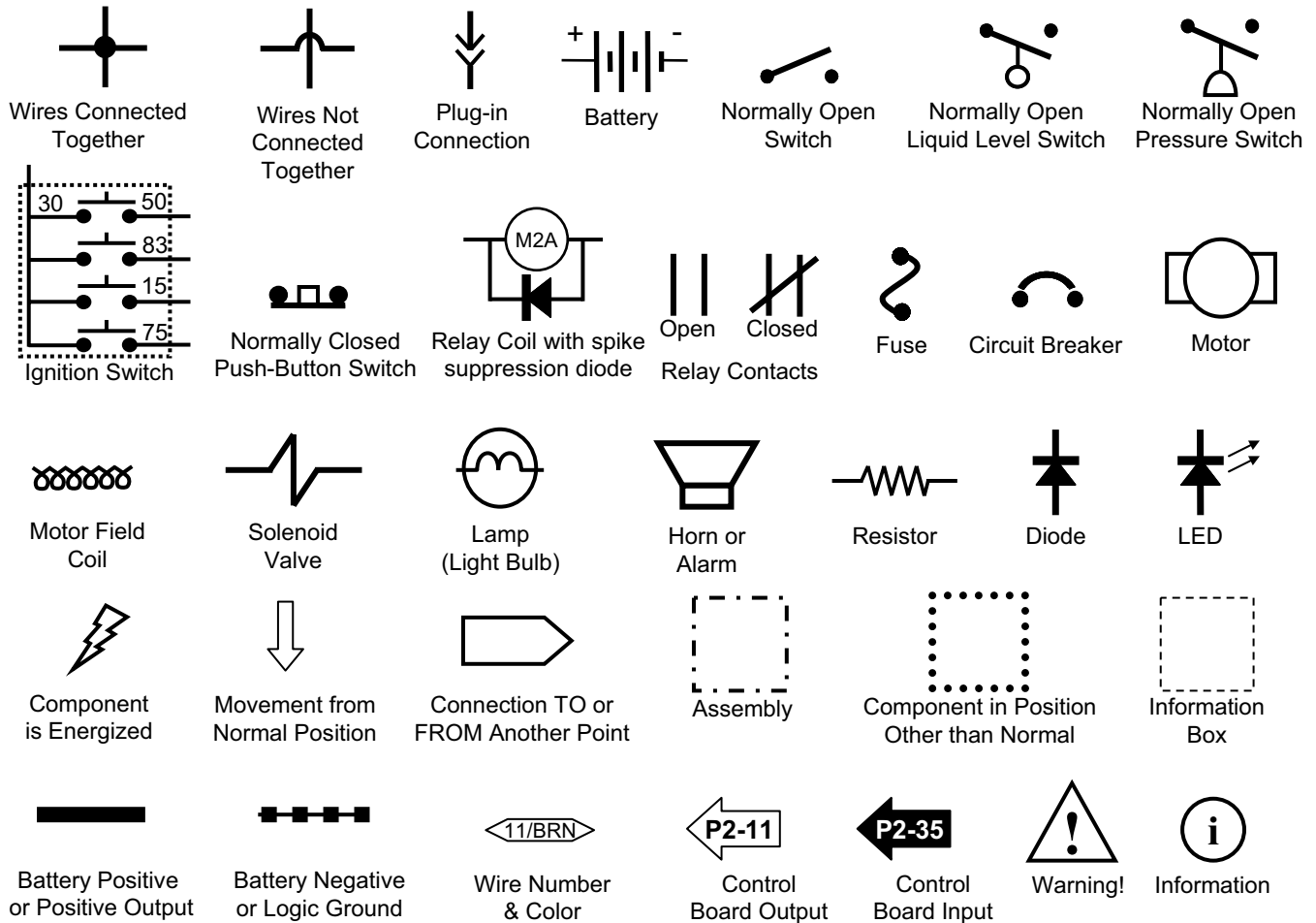

## Abbreviations

ACT	Actuator
ARM	Armature
CB	Circuit Breaker
D	diode
ES	Extended Scrub
FaST	Foam Scrubbing Technology
FU	Fuse
HM	Hour Meter
LED	Light Emitting Diode
M	Relay Coil

mm	Millimeter
MTR	Motor
N.C.	Normally Closed
N.O.	Normally Open
P	Connector Pin
R	Resistor
S or SW	Switch
SV	Solenoid Valve
VAC	Vacuum
VDC	Volts DC

# T15 Key Switch

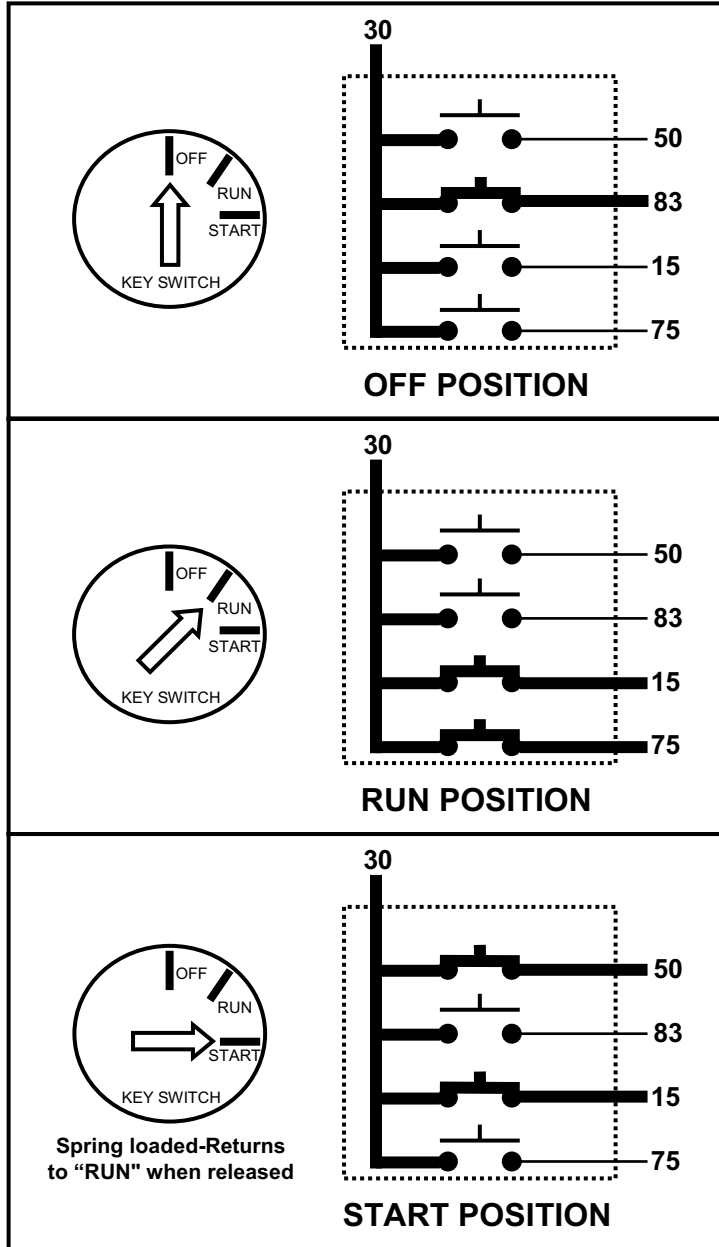

		SWITCH TERMINAL MARKING				
		30	50	83	15	75
SWITCH POSITION	OFF	●		●		
	RUN	●			●	●
	START	●	●		●	

“●—●” Indicates a common connection

**i** Common connections in various switch positions should be less than 1Ω

**E**

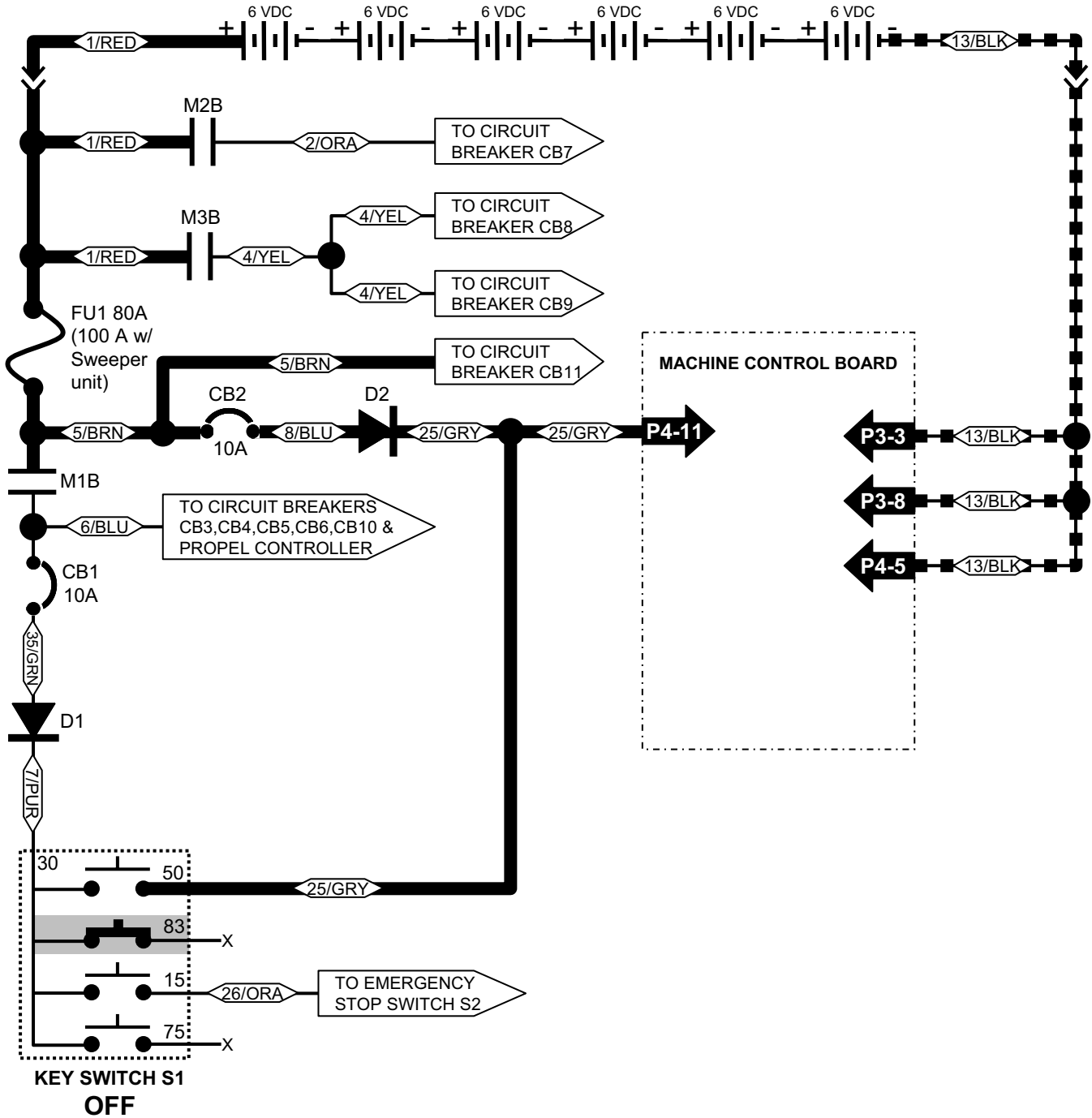

# T15 Key OFF Power Distribution

Conditions: Key OFF



## Wiring Color Codes

Abbreviation	Color of Wire
RED	Red
BLK	Black
WHT	White
GRY	Gray
BRN	Brown
PNK	Pink
ORA	Orange
YEL	Yellow
GRN	Green
BLU	Blue
PUR	Purple
CLR	Clear

 = Battery Negative or Logic Ground  
 = Battery Positive or Positive Output

**Be cautious when working near Control Board -**  
***Battery voltage is always present, even with Key OFF***

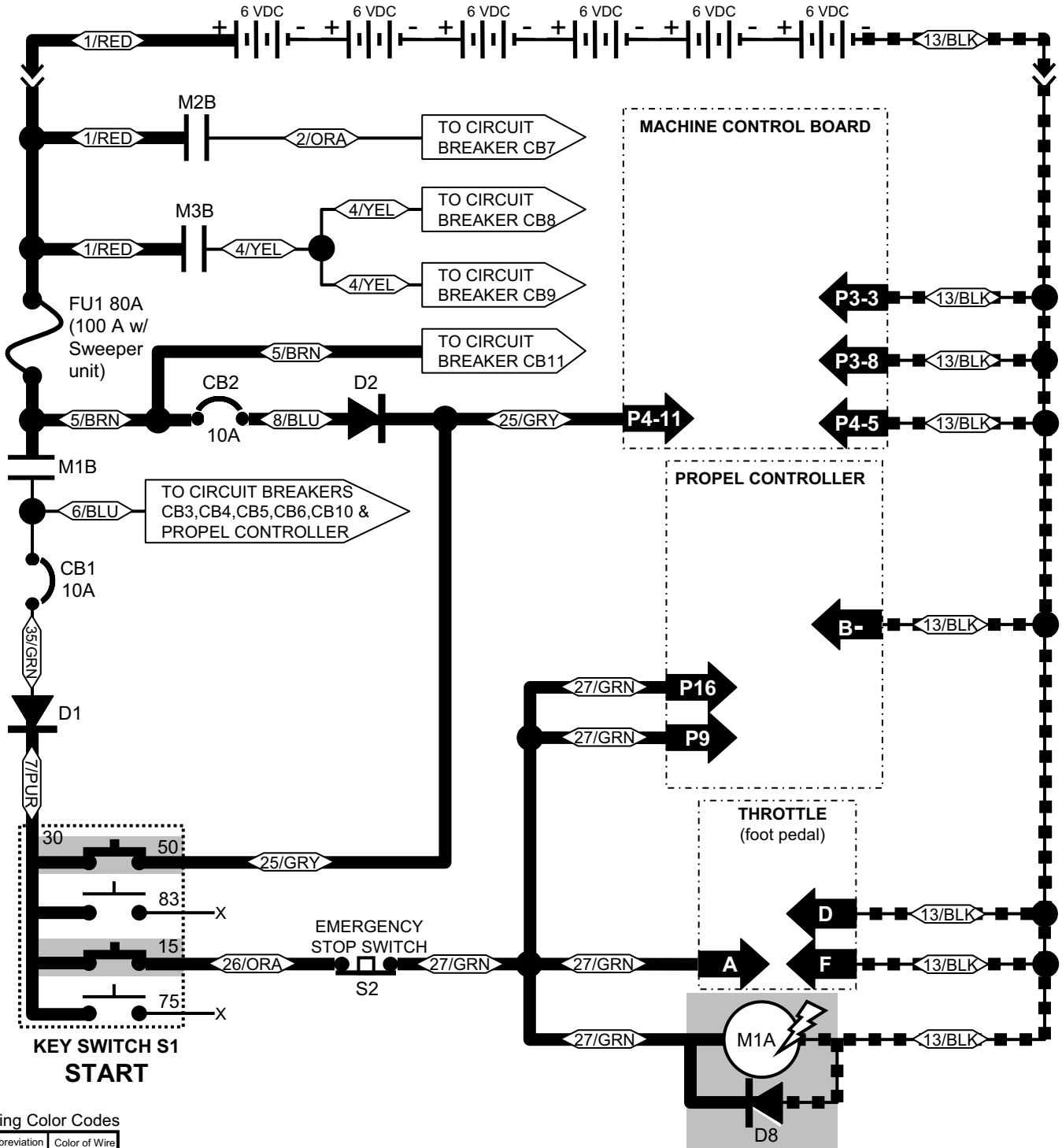

# T15 Key START Power Distribution

Conditions: Key in START



## Wiring Color Codes

Abbreviation	Color of Wire
RED	Red
BLK	Black
WHT	White
GRY	Gray
BRN	Brown
PNK	Pink
ORA	Orange
YEL	Yellow
GRN	Green
BLU	Blue
PUR	Purple
CLR	Clear

 = Battery Negative or Logic Ground  
 = Battery Positive or Positive Output



- Key MUST be put into START position to energize Main Contactor coil (M1A)
- This diagram shows how M1A receives power before the contacts (M1B) close

**Be cautious when working near Control Board - Battery voltage is always present, even with Key OFF**

# T15 Key ON Power Distribution

Conditions: Key in RUN (after START)

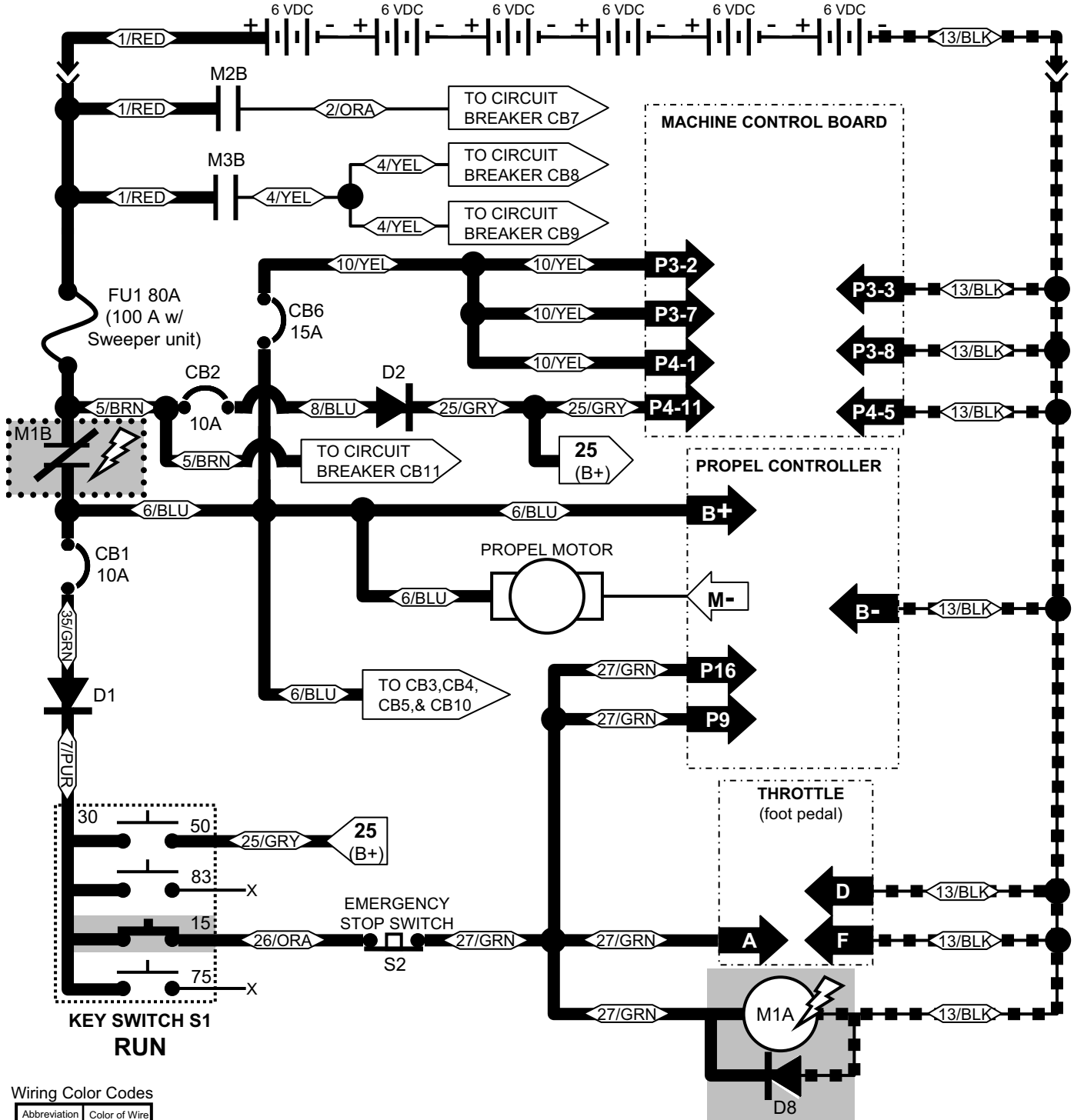

### Wiring Color Codes

Abbreviation	Color of Wire
RED	Red
BLK	Black
WHT	White
GRY	Gray
BRN	Brown
PNK	Pink
ORA	Orange
YEL	Yellow
GRN	Green
BLU	Blue
PUR	Purple
CLR	Clear

- = Battery Negative or Logic Ground
- = Battery Positive or Positive Output

Key MUST be put into START position before switching to the RUN position to energize Main Contactor coil (M1A)

Be cautious when working near Control Board - **Battery voltage is always present, even with Key OFF**

# T15 Power Up Troubleshooting

- OPERATION:**
- Key switch to to start position-** Current flows into key switch terminal 50  
Current flows out of key switch terminal 15, turning on M1 contactor and powering up the machine.
  - Release key to run position-** Current flows through closed M1 contacts, into key switch pin 30.  
Current flows out of key switch terminal 15, holding M1 contactor on, keeping machine powered up.
  - Key switch to off position-** M1 is turned off by key switch or emergency stop switch.  
Machine turns off.

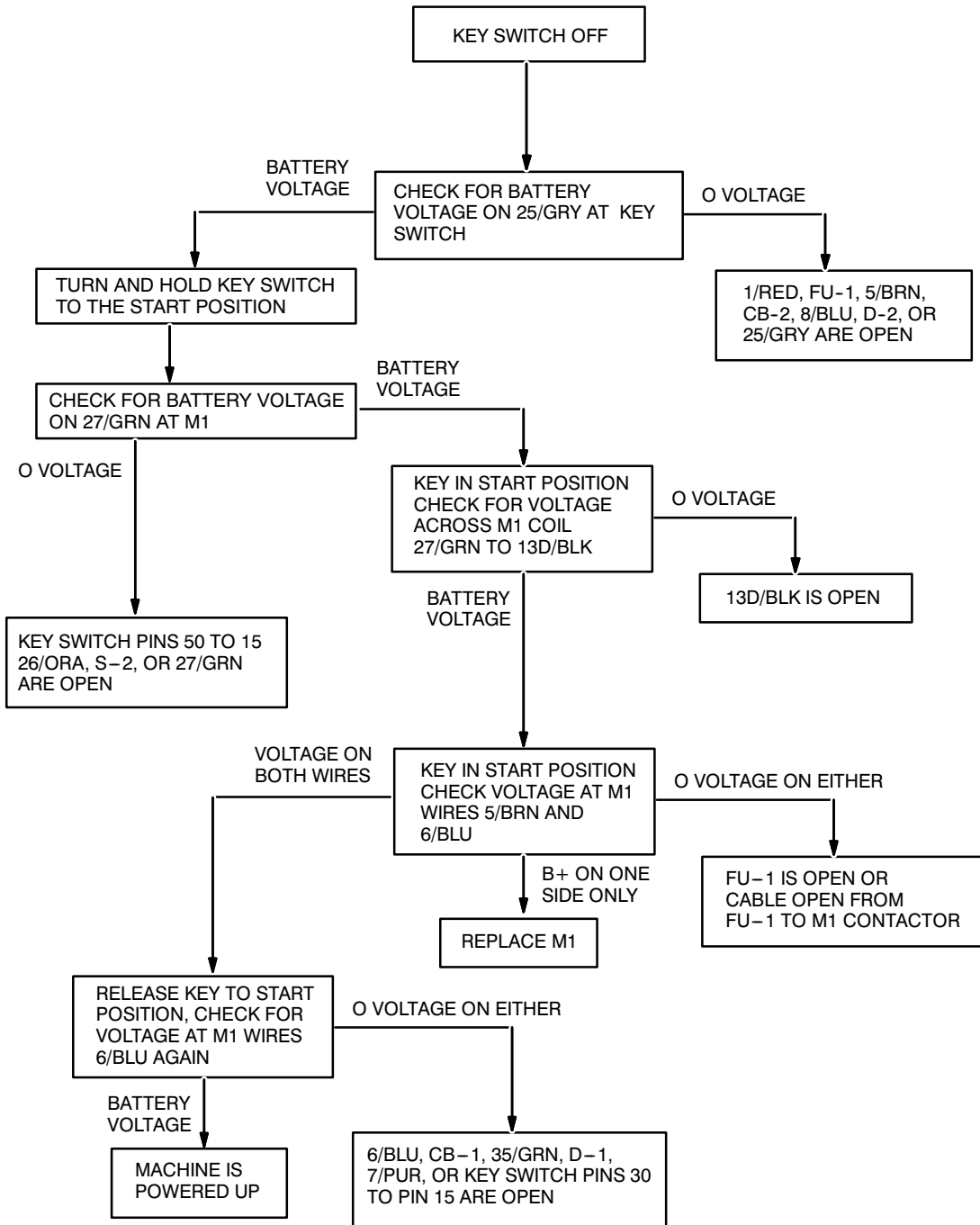

# T15 Touch Panel Wiring

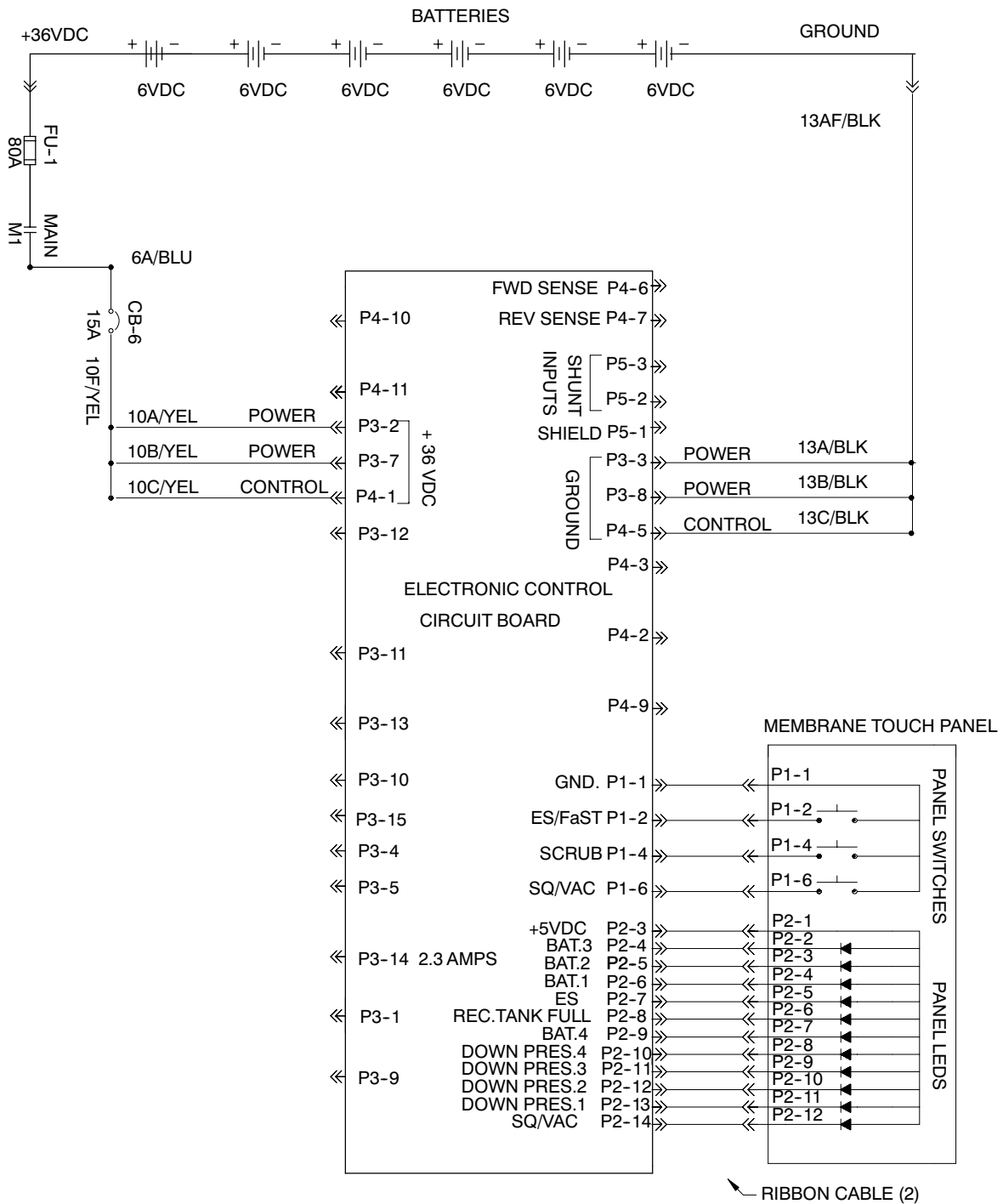

# T15 Touch Panel Troubleshooting

## OPERATION OF LED'S:

- P2-1 = Supplies +5VDC to each LED
- P2-4 through P2-14 will light an LED if they are pulled to ground by the control board

## OPERATION OF SWITCHES:

- P1-1 = Supplies ground to each switch
- P1-2 = Switched to ground when the ES switch is activated
- P1-4 = Switched to ground when the Scrub button is activated
- P1-6 = Switched to ground when the Squeegee button is activated

\* MACHINE POWERS UP AND PROPELS

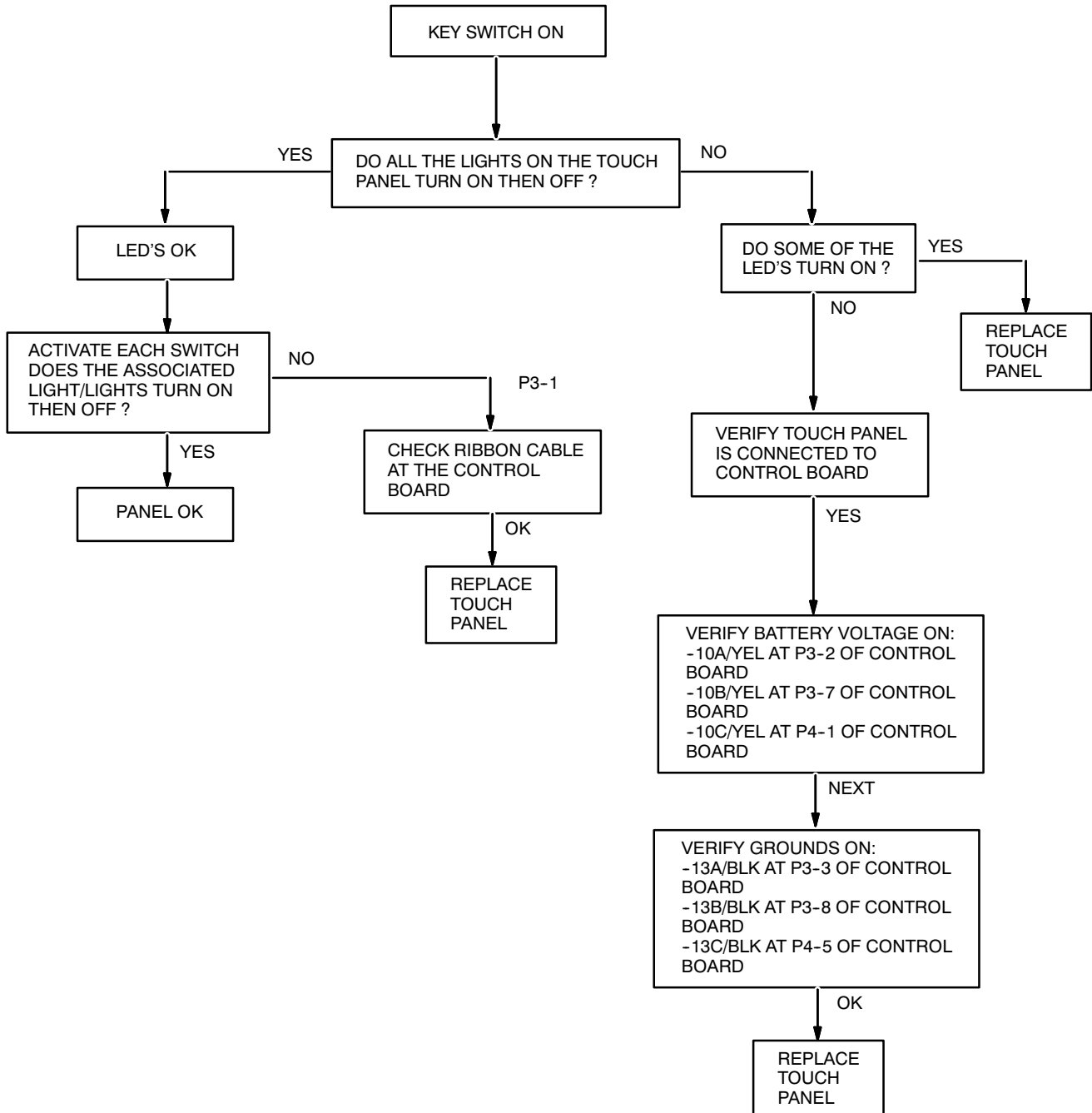



# T15 Scrub Brushes ON

Conditions: Key ON, operator on seat, scrubbing system ON, propel forward or reverse

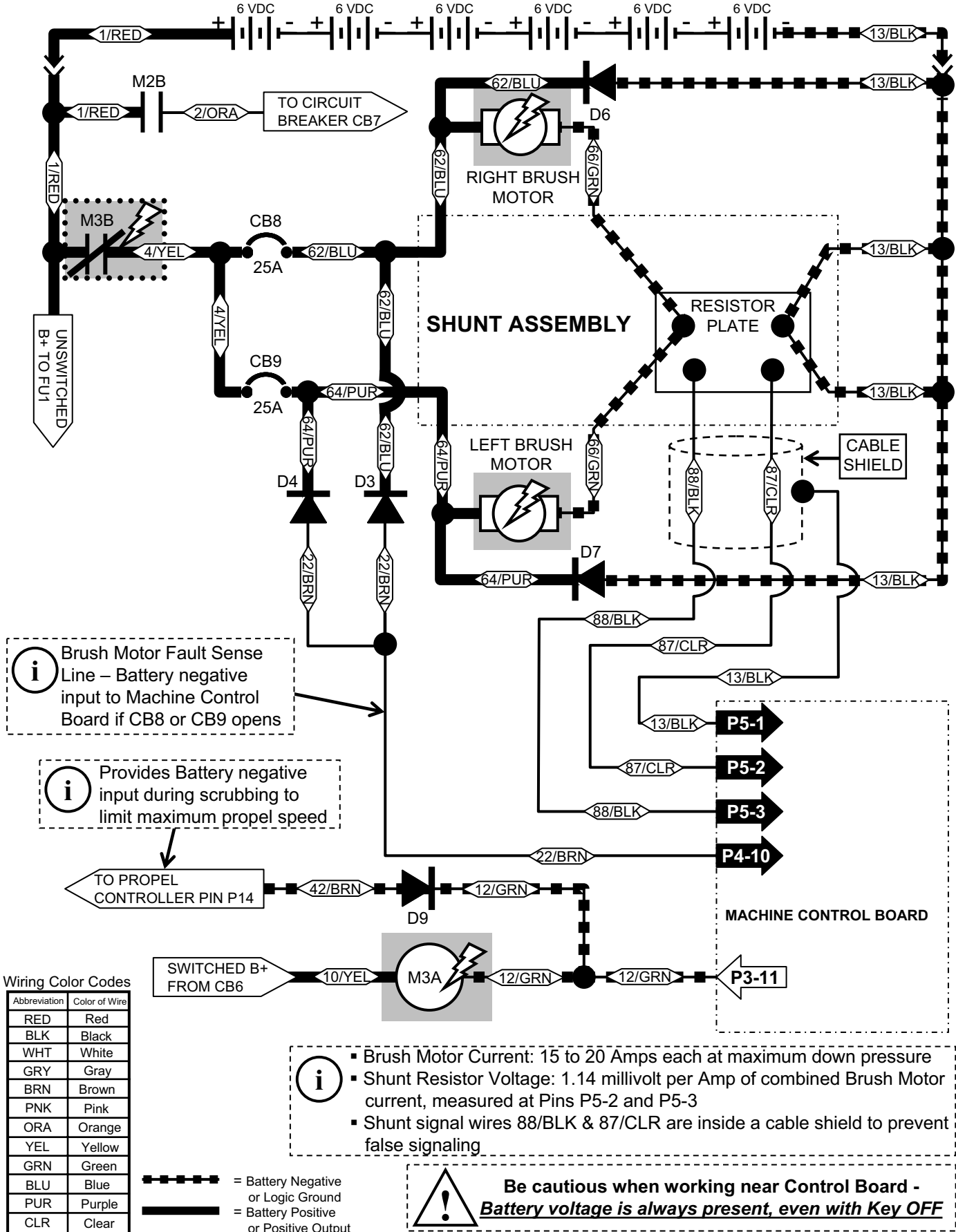

# T15 Vacuum Fan(s) ON & Squeegee DOWN

Conditions: Key ON, squeegee/vacuum ON, propel forward or neutral, recovery tank NOT FULL

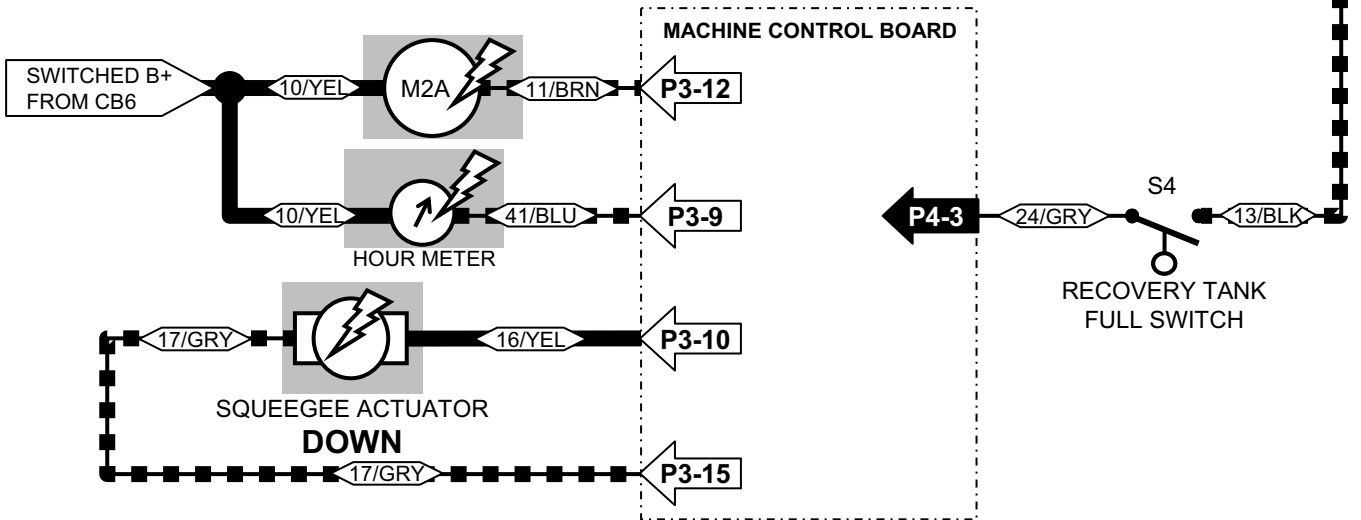
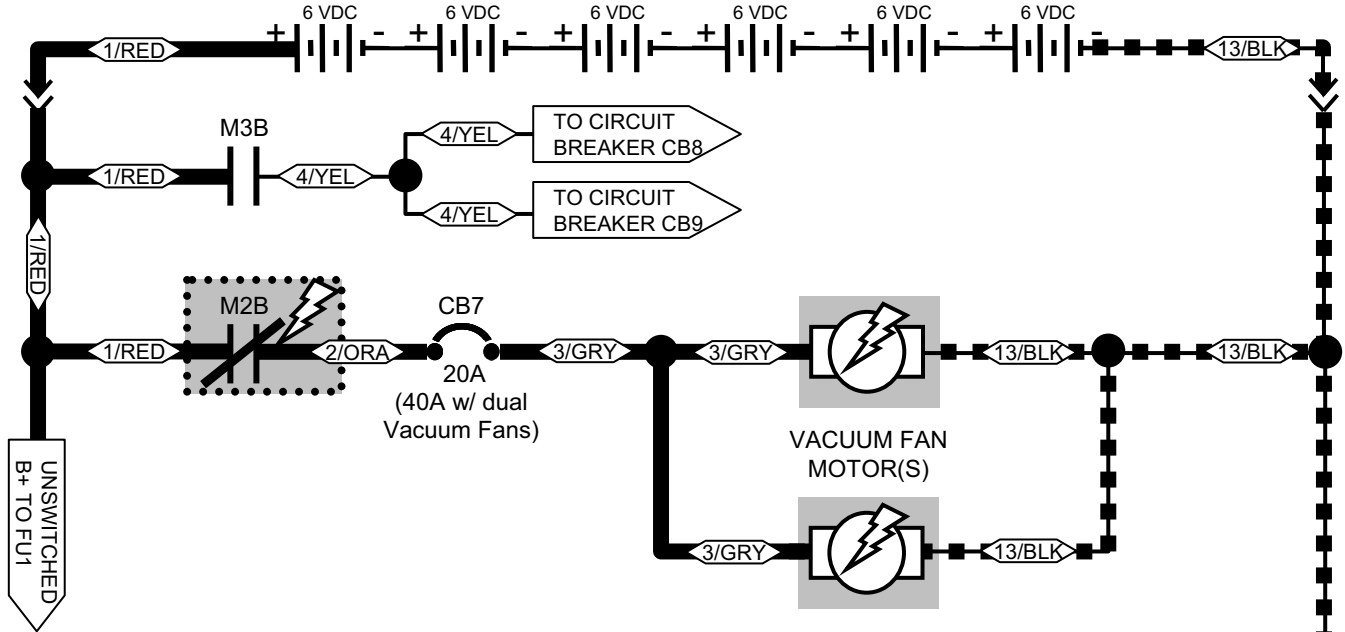

- i** Vacuum Fan Motor Current: 17 Amps each (+/- 10%)
- When the Recovery Tank is FULL, the Scrubbing System and Vacuum Fan(s) will turn OFF, and the Squeegee will raise after a short time delay
- The Hour Meter is energized when vacuum fan(s) are running or anytime during forward or reverse propel

## Wiring Color Codes

Abbreviation	Color of Wire
RED	Red
BLK	Black
WHT	White
GRY	Gray
BRN	Brown
PNK	Pink
ORA	Orange
YEL	Yellow
GRN	Green
BLU	Blue
PUR	Purple
CLR	Clear

= Battery Negative or Logic Ground  
 = Battery Positive or Positive Output

**Be cautious when working near Control Board - Battery voltage is always present, even with Key OFF**

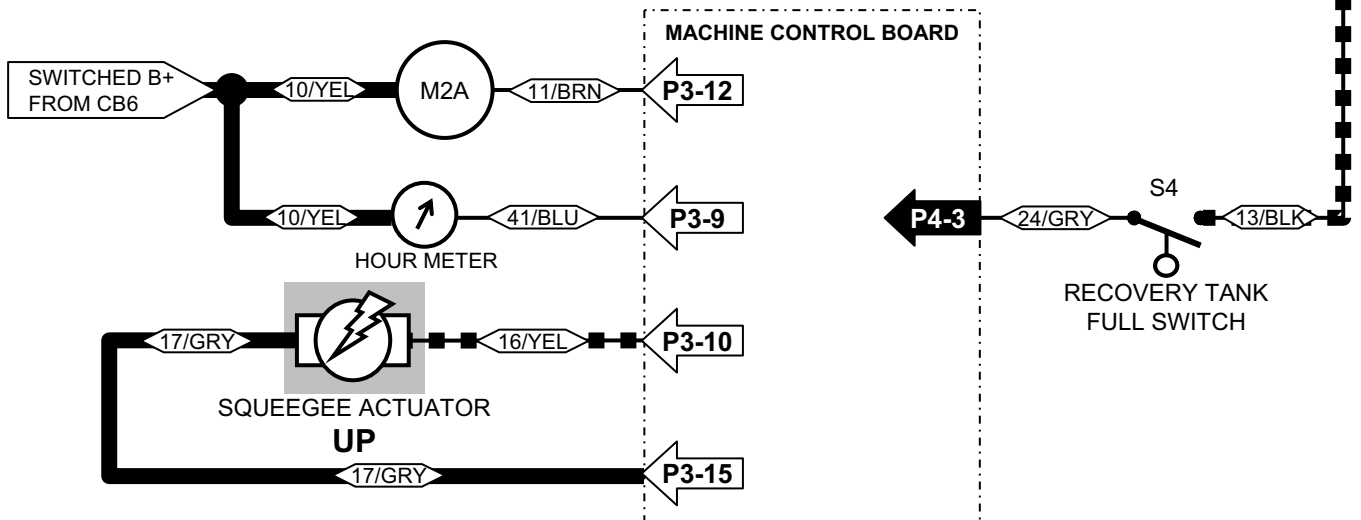
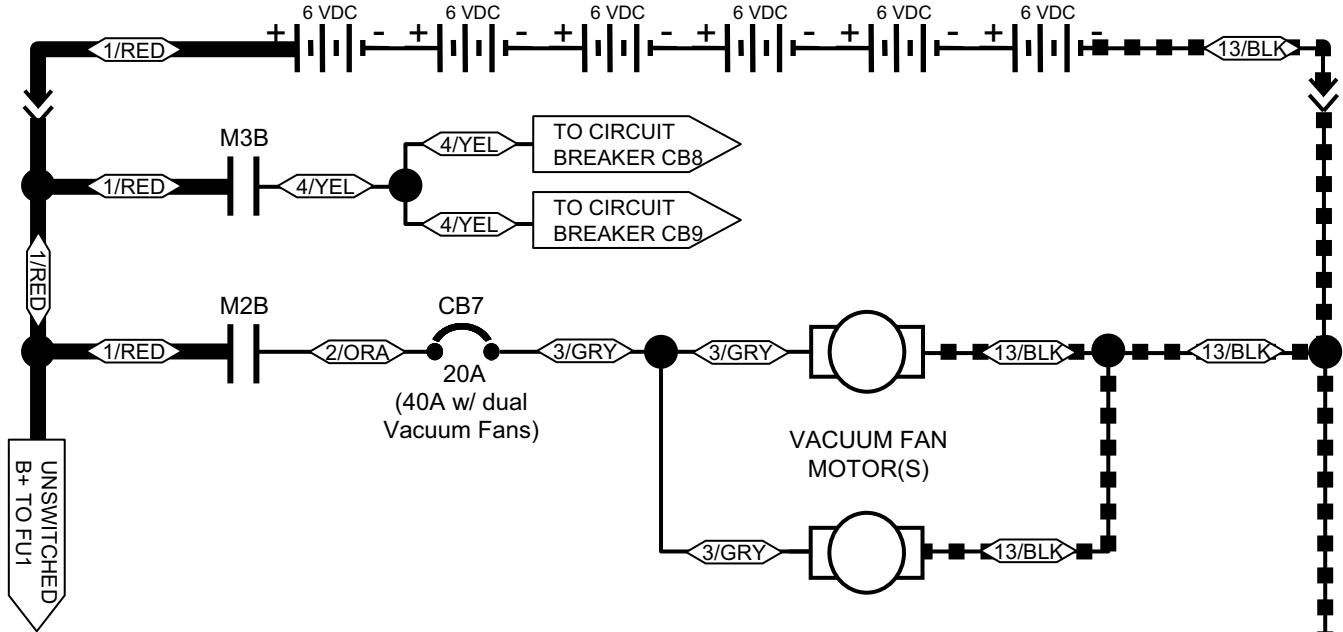

# T15 Vacuum Fan(s) OFF & Squeegee UP

Conditions: Key ON, scrubbing system OFF or squeegee/vacuum OFF or reverse propel or recovery tank FULL



## Wiring Color Codes

Abbreviation	Color of Wire
RED	Red
BLK	Black
WHT	White
GRY	Gray
BRN	Brown
PNK	Pink
ORA	Orange
YEL	Yellow
GRN	Green
BLU	Blue
PUR	Purple
CLR	Clear

 = Battery Negative or Logic Ground  
 = Battery Positive or Positive Output



- Reverse propel will raise the squeegee immediately and turn OFF vacuum fan(s) after a short time delay; neutral or forward propel will restart the vacuum fan(s) and re-lower the squeegee
- When the Recovery Tank is FULL, the Scrubbing System and Vacuum Fan(s) will turn OFF, and the Squeegee will raise after a short time delay
- The Hour Meter is energized when vacuum fan(s) are running or anytime during forward or reverse propel



**Be cautious when working near Control Board - Battery voltage is always present, even with Key OFF**



# T15 Vacuum Fan Troubleshooting

**OPERATION:** To enable the vacuum fan, the following conditions must occur–

- 1.– Vacuum fan/squeegee system selected on the touch panel
- 2.– Machine in neutral or forward position
- 3.– No "low battery" condition sensed
- 4.– No "full recovery tank" condition sensed

**VACUUM MOTOR TURNS ON:**

- 1.– 11/BRN is switched to ground at control board P3–12, turning on M2 contactor
- 2.– M2 contactor supplies battery voltage to the vacuum fan(s), turning them on

\* MACHINE POWERS UP, TOUCH PANEL AND PROPEL SYSTEMS TEST GOOD

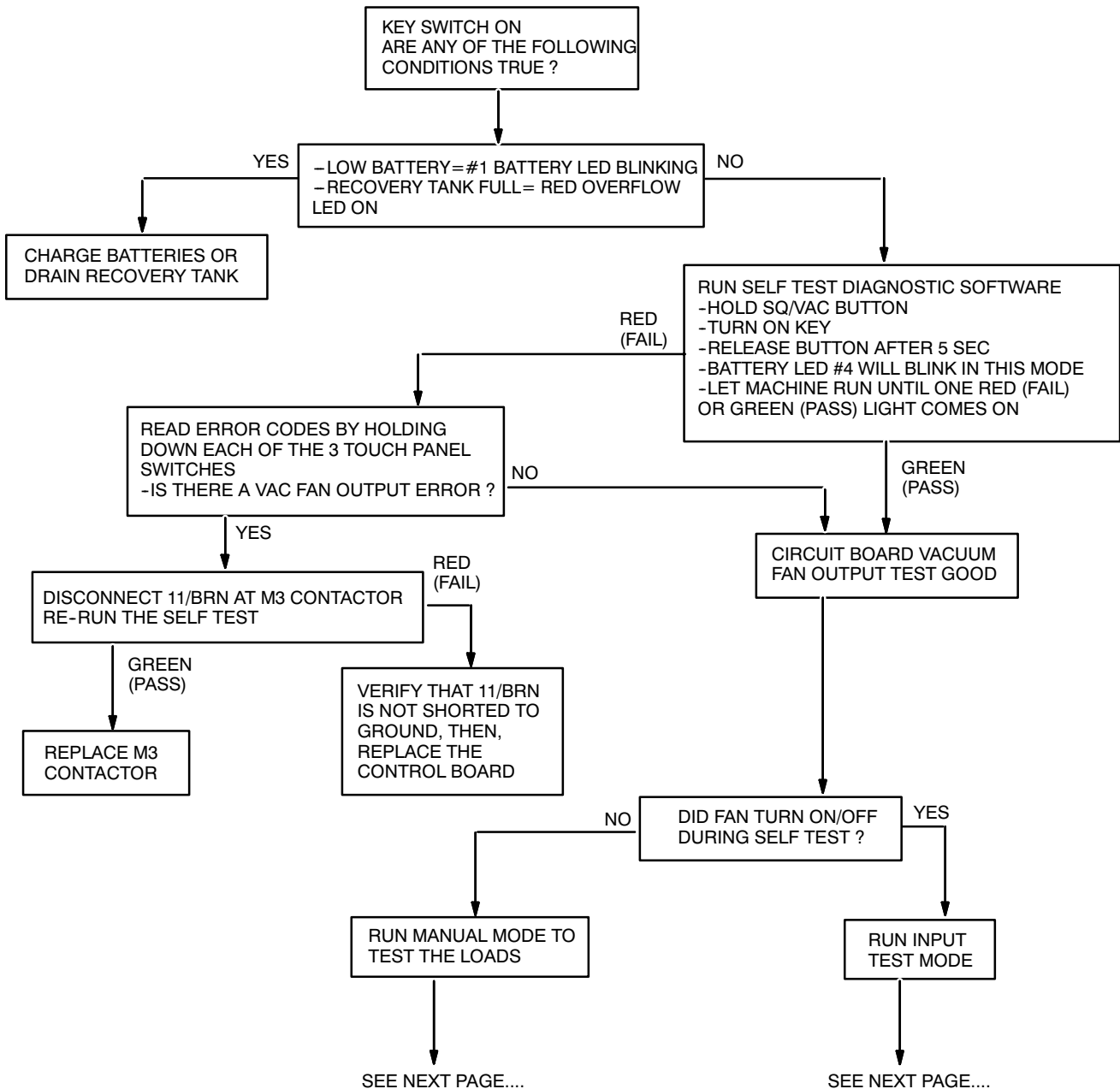

# T15 Vacuum Fan Troubleshooting (cont'd)

CONTINUED FROM PREVIOUS PAGE

RUN MANUAL MODE TO TEST THE LOADS

-HOLD ES/FAST BUTTON  
 -TURN KEY ON  
 -RELEASE BUTTON AFTER 5 SEC  
 -#3 BATTERY LED WILL BLINK IN MANUAL MODE

ACTIVATE SQUEEGEE/VAC FAN TOUCH PANEL BUTTON  
 -DOES THE VAC FAN TURN ON?

YES

GO TO INPUT TESTING MODE

NO

CHECK FOR BATTERY VOLTAGE FROM:  
 -3A/GRY TO 13AF/BLK AT THE VAC FAN

0 VOLTAGE

BATTERY VOLTAGE

REPLACE VAC FAN

THE CONTROL BOARD IS SWITCHING 11/BRN AT P3-12 TO GROUND TO TURN ON M2--M2 IS BAD OR  
 -10D/YEL, 11/BRN, 1A/OR, CB-7, 3/GRY, OR 13AF/BLK ARE OPEN

CONTINUED FROM PREVIOUS PAGE

RUN INPUT TEST MODE

-HOLD SCRUB BUTTON  
 -TURN ON KEY  
 -RELEASE SCRUB BUTTON AFTER 5 SEC  
 -#2 DOWN PRESS LIGHT WILL BLINK IN INPUT MODE

YES

IS BATTERY LED #2 ON ? (SECOND FROM LEFT)

NO

MACHINE TESTS GOOD

29A/GRY AT P4-7 IS SWITCHED TO 36 VDC --THIS SHOULD ONLY HAPPEN IN REVERSE--GO TO PROPEL SYSTEM TESTING



# T15 Squeegee Troubleshooting

**OPERATION:** To lower the squeegee actuator, the following conditions must occur–

- 1.– Vacuum fan/squeegee system selected on the touch panel
- 2.– Machine in neutral or forward position
- 3.– No "low battery" condition sensed
- 4.– No "full recovery tank" condition sensed

**SQUEEGEE ACTUATOR EXTEND OR RETRACT:**

- 1.– 16/YEL at P3–10 and 17/GRY at P3–15 are both at battery voltage in the off position
- 2.– Is pulsed low to extend, is pulsed low to retract the squeegee actuator

\* MACHINE POWERS UP, TOUCH PANEL AND PROPEL SYSTEMS TEST GOOD

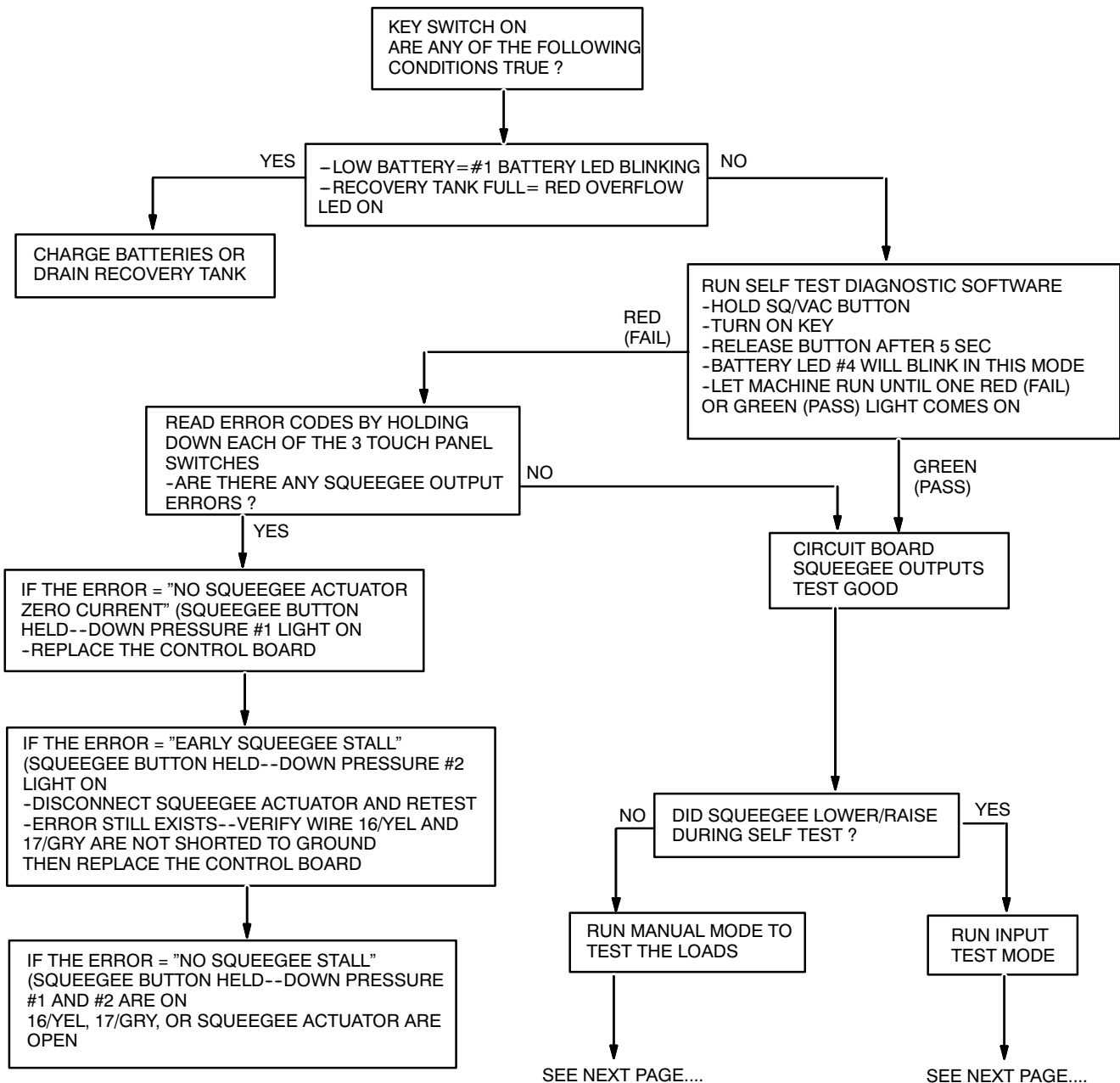

# T15 Squeegee Troubleshooting (cont'd)

CONTINUED FROM PREVIOUS PAGE

RUN MANUAL MODE TO TEST THE LOADS

- HOLD ES BUTTON  
 - TURN KEY ON  
 - RELEASE BUTTON AFTER 5 SEC  
 - #3 BATTERY LED WILL BLINK IN MANUAL MODE

ACTIVATE SQUEEGEE/VAC FAN TOUCH PANEL BUTTON  
 - DOES THE SQUEEGEE ACTUATOR LOWER ?

YES

GO TO INPUT TESTING MODE

NO

DISCONNECT SQUEEGEE ACTUATOR  
 MEASURE VOLTAGE FROM 16/YEL TO 17/GRY AT SQUEEGEE ACTUATOR

0 VOLTAGE

BATTERY VOLTAGE  
 OR - BATTERY VOLTAGE

REPLACE ACTUATOR

16/YEL OR 17/GRY ARE OPEN

CONTINUED FROM PREVIOUS PAGE

RUN INPUT TEST MODE

- HOLD SCRUB BUTTON  
 - TURN ON KEY  
 - RELEASE SCRUB BUTTON AFTER 5 SEC  
 - #2 DOWN PRESS LIGHT WILL BLINK IN INPUT MODE

YES

IS BATTERY LED #2 ON ?  
 (SECOND FROM LEFT)

NO

MACHINE TESTS GOOD

29A/GRY AT P4-7 IS SWITCHED TO 36 VDC -- THIS SHOULD ONLY HAPPEN IN REVERSE -- GO TO PROPEL SYSTEM TESTING



# T15 Scrub Head DOWN & Conventional Solution Valve ON

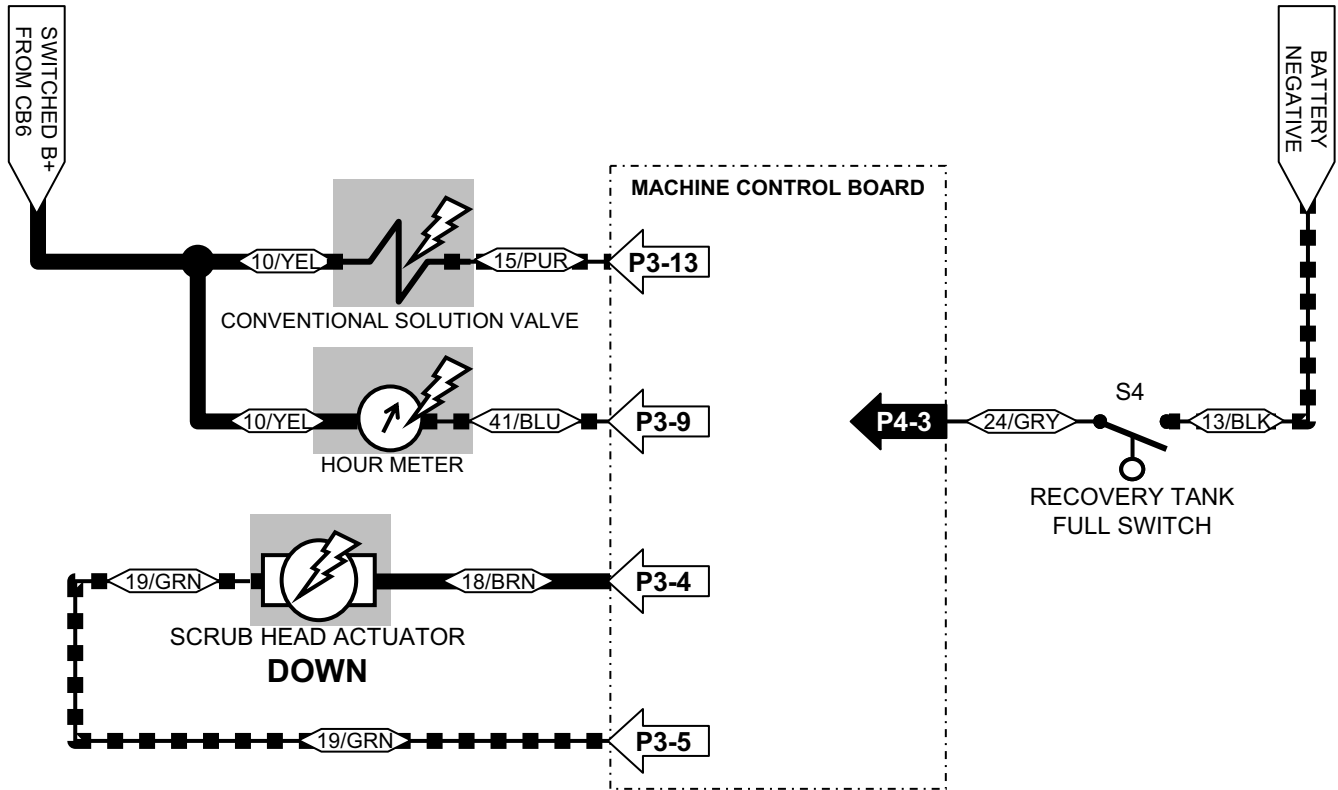

Conditions: Key ON, operator on seat, scrubbing system ON, recovery tank NOT FULL, propel forward or reverse



- 
 During Scrubbing, when machine is not being propelled (in neutral), the Conventional Solution Valve will turn OFF, the Scrub Brushes will turn OFF, and the Scrub Head Actuator will slightly lift the Scrub Head after a short time delay
- The Hour Meter is energized when vacuum fan(s) are running or anytime during forward or reverse propel

## Wiring Color Codes

Abbreviation	Color of Wire
RED	Red
BLK	Black
WHT	White
GRY	Gray
BRN	Brown
PNK	Pink
ORA	Orange
YEL	Yellow
GRN	Green
BLU	Blue
PUR	Purple
CLR	Clear

 = Battery Negative or Logic Ground  
 = Battery Positive or Positive Output



**Be cautious when working near Control Board - Battery voltage is always present, even with Key OFF**



# T15 Scrub Head UP

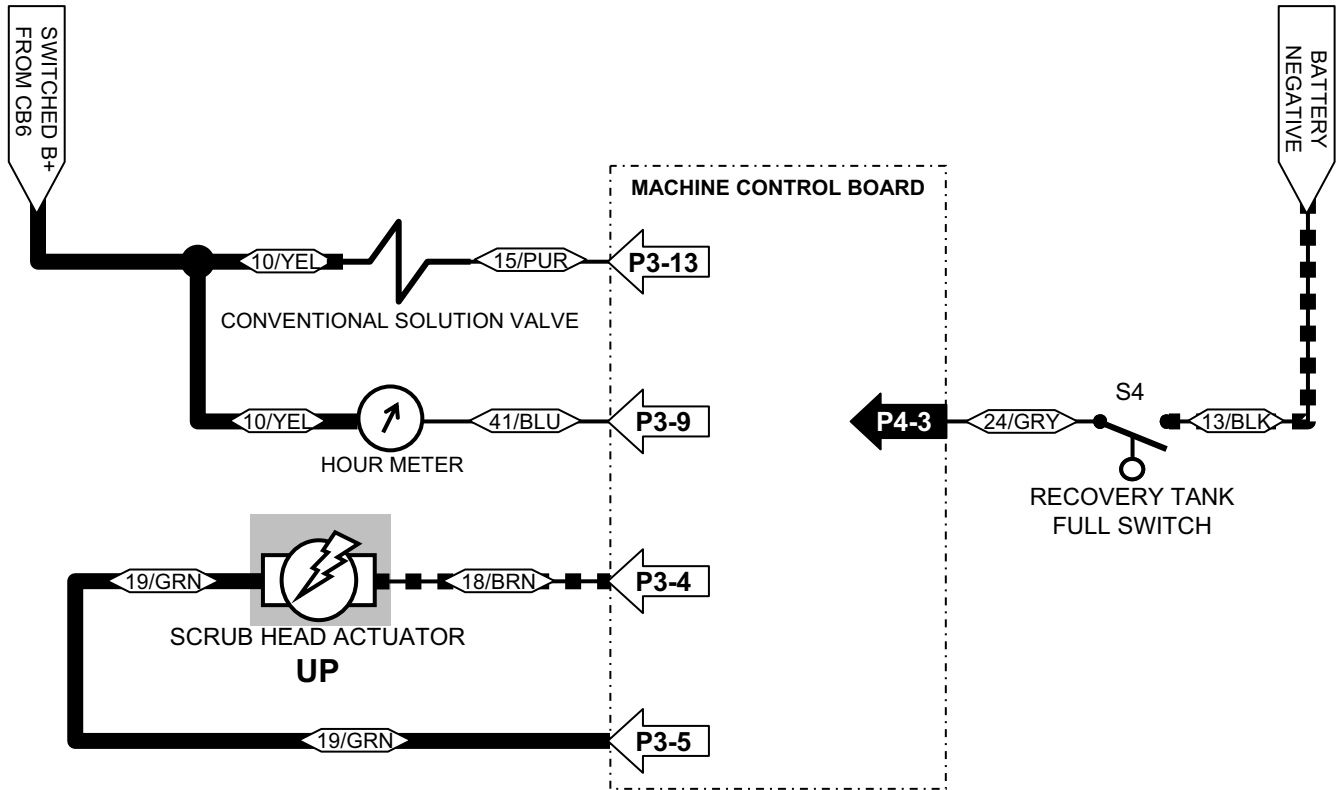

Conditions: Key ON, scrubbing system OFF or recovery tank FULL



- 
 During Scrubbing, when machine is not being propelled (in neutral), the Conventional Solution Valve will turn OFF, the Scrub Brushes will turn OFF, and the Scrub Head Actuator will slightly lift the Scrub Head after a short time delay
- The Hour Meter is energized when vacuum fan(s) are running or anytime during forward or reverse propel

## Wiring Color Codes

Abbreviation	Color of Wire
RED	Red
BLK	Black
WHT	White
GRY	Gray
BRN	Brown
PNK	Pink
ORA	Orange
YEL	Yellow
GRN	Green
BLU	Blue
PUR	Purple
CLR	Clear

 = Battery Negative or Logic Ground  
 = Battery Positive or Positive Output

**Be cautious when working near Control Board - Battery voltage is always present, even with Key OFF**

# T15 Forward Propel

Conditions: Key ON, operator on seat, throttle depressed for forward travel

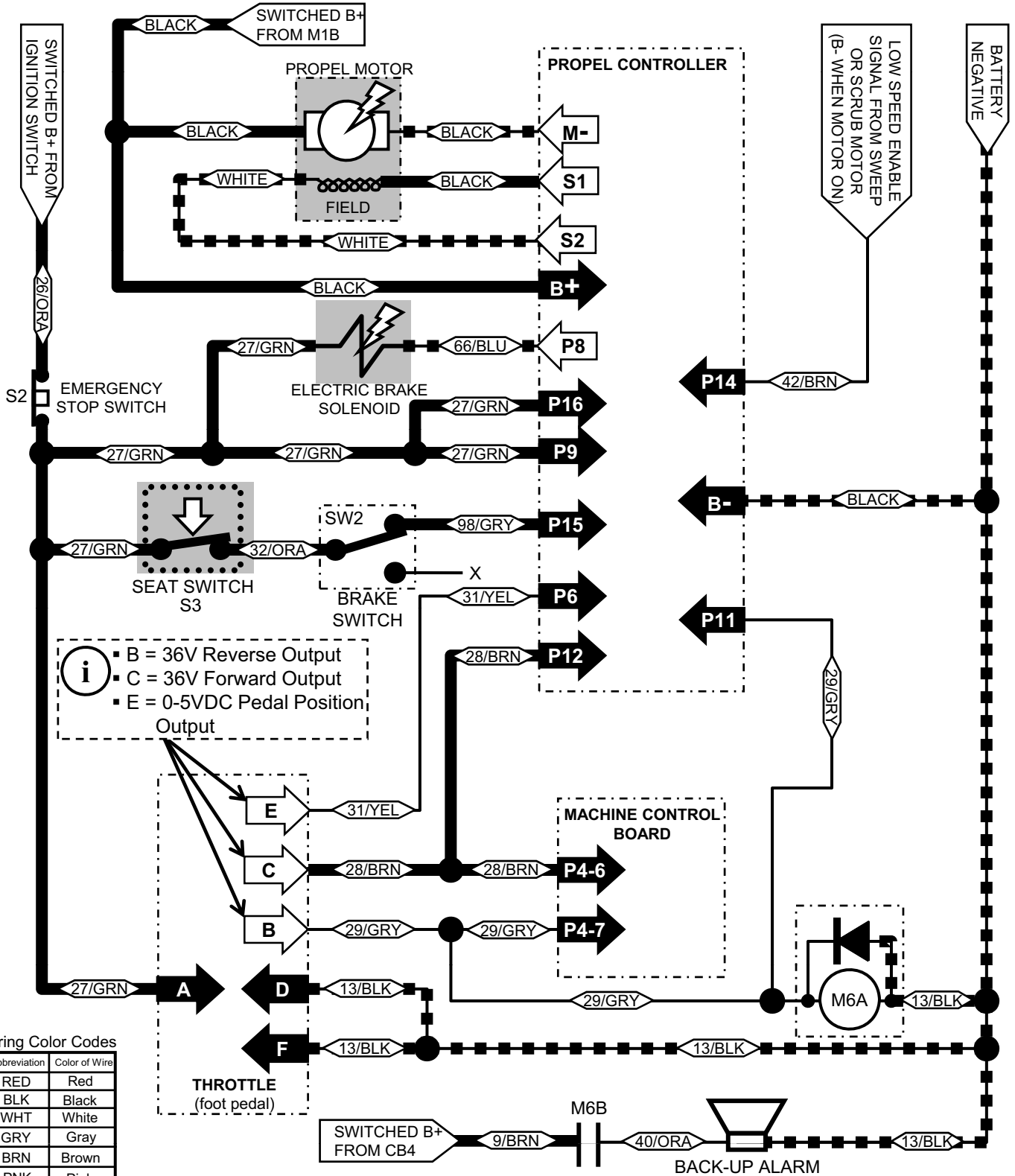

**i** B = 36V Reverse Output  
 C = 36V Forward Output  
 E = 0-5VDC Pedal Position Output

**Wiring Color Codes**

Abbreviation	Color of Wire
RED	Red
BLK	Black
WHT	White
GRY	Gray
BRN	Brown
PNK	Pink
ORA	Orange
YEL	Yellow
GRN	Green
BLU	Blue
PUR	Purple
CLR	Clear

--- = Battery Negative or Logic Ground  
 — = Battery Positive or Positive Output

**Be cautious when working near Control Board - Battery voltage is always present, even with Key OFF**

# T15 Reverse Propel

Conditions: Key ON, operator on seat, throttle depressed for reverse travel

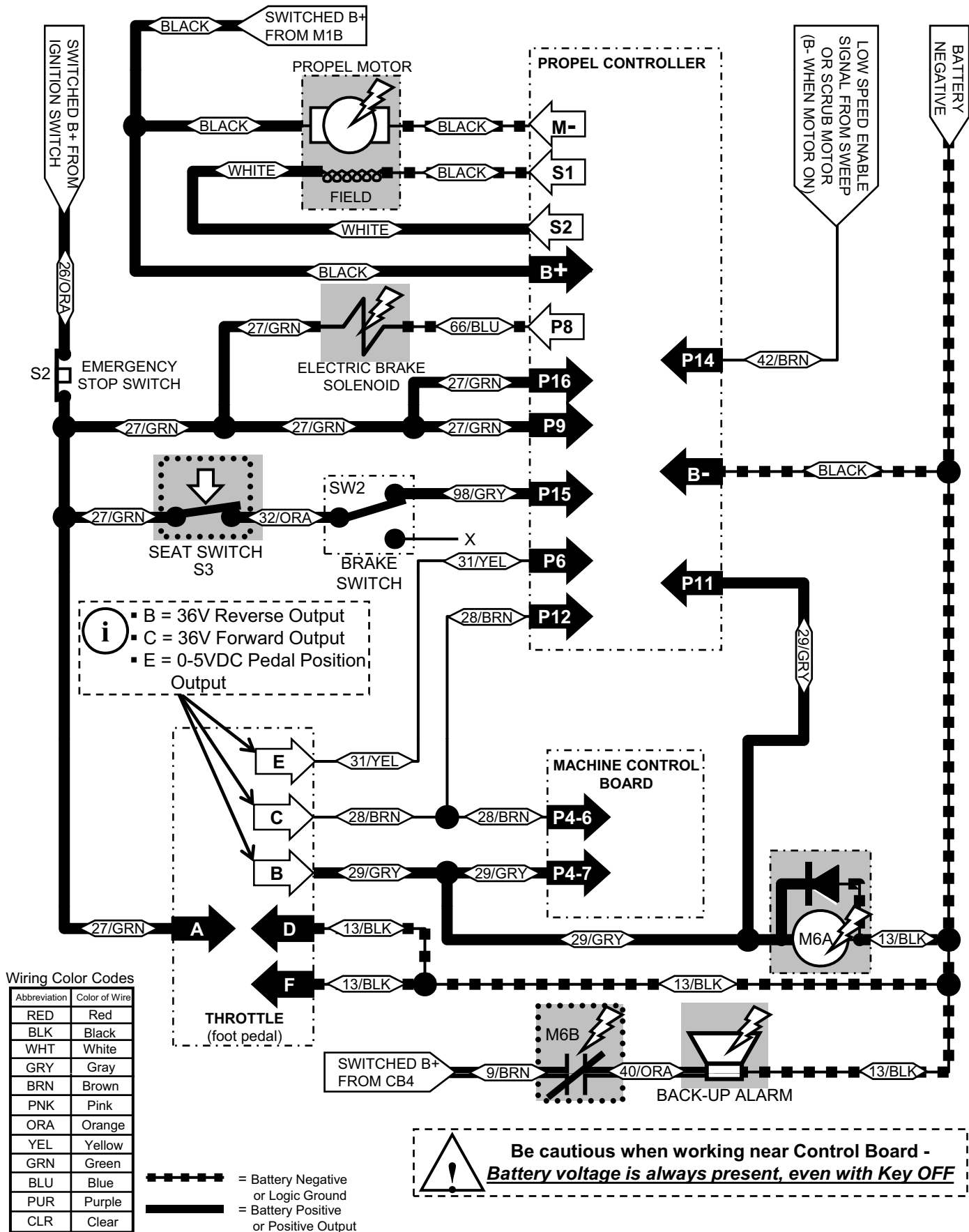

# T15 Neutral (No Propel) with Brake Pedal Depressed

Conditions: Key ON, operator on seat, throttle NOT depressed, brake pedal depressed

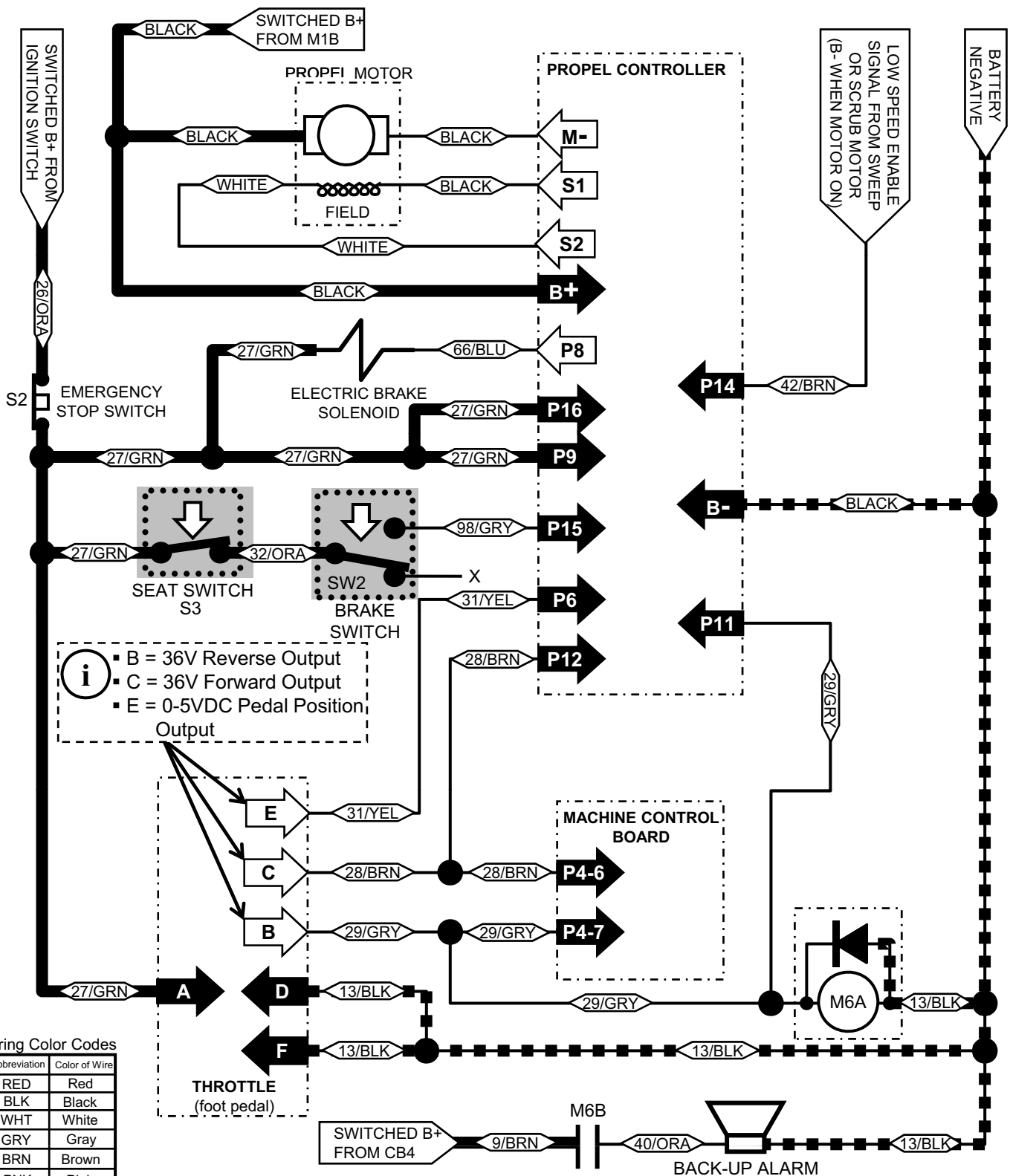

**Be cautious when working near Control Board - Battery voltage is always present, even with Key OFF**

# T15 Propel Controller

(page 1 of 3)

## DIAGNOSTICS AND TROUBLESHOOTING

The propel controller provides diagnostics information to assist technicians in troubleshooting drive system problems. The diagnostics information can be obtained by the fault codes issued by a Status LED. Refer to the Propel Controller Troubleshooting Chart for suggestions covering a wide range of possible faults.

The Status LED is built into the propel controller. It is visible through a window in the label on top of the controller. This Status LED displays fault codes when there is a problem with the controller or with the inputs to the controller. During normal operation, with no faults present, the Status LED flashes steadily on and off. If the controller detects a fault, a 2-digit fault identification code is flashed continuously until the fault is corrected. For example, code “3,2”—main contactor welded—appears as:

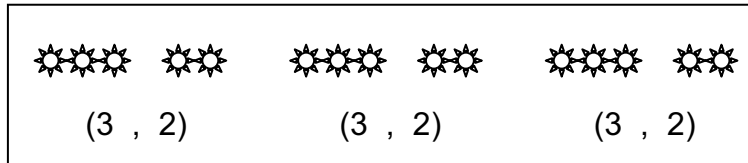

Only one fault is indicated at a time, and faults are not queued up. Refer to the troubleshooting chart for suggestions about possible causes of the various faults.

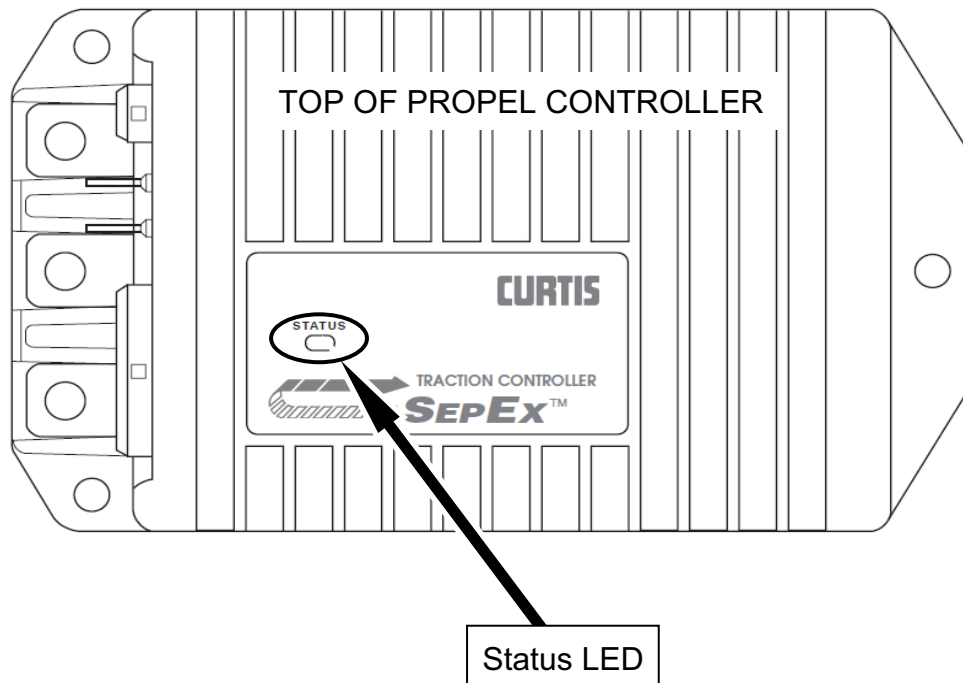

# T15 Propel Controller

(page 2 of 3)

## PROPEL CONTROLLER TROUBLESHOOTING CHART

LED CODE	PROGRAMMER LCD DISPLAY	FAULT CATEGORY	POSSIBLE CAUSE	FAULT CLEARANCE
0,1	NO KNOWN FAULTS	0	n/a	n/a
1,1	CURRENT SHUNT FAULT	1	<ol style="list-style-type: none"> <li>1. Abnormal vehicle operation causing high current spikes.</li> <li>2. Current sensor out of range.</li> <li>3. Controller failure.</li> </ol>	Cycle KSI. If problem persists, replace controller.
1,2	HW FAILSAFE	1	<ol style="list-style-type: none"> <li>1. Noisy environment.</li> <li>2. Self-test or watchdog fault.</li> <li>3. Controller failure.</li> </ol>	Cycle KSI. If problem persists, replace controller.
1,3	M- SHORTED	1	<ol style="list-style-type: none"> <li>1. Internal or external short of M- to B-.</li> <li>2. Incorrect motor wiring.</li> <li>3. Controller failure.</li> </ol>	Check wiring; cycle KSI. If problem persists, replace controller.
1,4	SRO	3	<ol style="list-style-type: none"> <li>1. Improper sequence of KSI, interlock, and direction inputs.</li> <li>2. Interlock or direction switch circuit open.</li> <li>3. Sequencing delay too short.</li> <li>4. Wrong SRO or throttle type selected.</li> <li>5. Misadjusted throttle pot.</li> </ol>	Follow proper sequence; adjust throttle if necessary; adjust programmable parameters if necessary.
2,1	THROTTLE WIPER HI	1	<ol style="list-style-type: none"> <li>1. Throttle input wire open or shorted to B+.</li> <li>2. Defective throttle pot.</li> <li>3. Wrong throttle type selected.</li> </ol>	When Throttle Wiper High input returns to valid range.
2,2	EMR REV WIRING	1	<ol style="list-style-type: none"> <li>1. Emergency reverse wire or check wire open.</li> </ol>	Re-apply emergency reverse or cycle interlock.
2,3	HPD	3	<ol style="list-style-type: none"> <li>1. Improper sequence of KSI, interlock, and throttle inputs.</li> <li>2. Misadjusted throttle pot.</li> <li>3. Sequencing delay too short.</li> <li>3. Wrong HPD or throttle type selected.</li> <li>5. Misadjusted throttle pot.</li> </ol>	Follow proper sequence; adjust throttle if necessary; adjust programmable parameters if necessary.
	SRVC TOTAL	3	<ol style="list-style-type: none"> <li>1. Total maintenance timer expired.</li> </ol>	Reset with programmer.
	SRVC TRAC	3	<ol style="list-style-type: none"> <li>1. Traction maintenance timer expired.</li> </ol>	Reset with programmer.
	TOTAL DISABLED	3	<ol style="list-style-type: none"> <li>1. Total disable timer expired.</li> </ol>	Reset with programmer.
	TRAC DISABLED	3	<ol style="list-style-type: none"> <li>1. Traction disable timer expired.</li> </ol>	Reset with programmer.
2,4	THROTTLE WIPER LO	1	<ol style="list-style-type: none"> <li>1. Throttle pot wire open or shorted to B+.</li> <li>2. Wrong throttle type selected.</li> <li>3. Defective throttle pot.</li> </ol>	When Throttle Wiper Low input returns to valid range.
3,1	FIELD SHORT	1	<ol style="list-style-type: none"> <li>1. Main contactor coil shorted.</li> <li>2. Field winding shorted to B+ or B-.</li> <li>3. Field resistance too low.</li> </ol>	Check contactor coil and field winding; cycle KSI.
3,2	MAIN CONT WELDED	1	<ol style="list-style-type: none"> <li>1. Main contactor stuck closed.</li> <li>2. Main contactor driver shorted.</li> </ol>	Check wiring and contactor; cycle KSI.
3,3	FIELD OPEN	1	<ol style="list-style-type: none"> <li>1. Field winding connection open.</li> <li>2. Field winding open.</li> </ol>	Check wiring and cycle KSI.
3,4	MISSING CONTACTOR	1	<ol style="list-style-type: none"> <li>1. Main contactor coil open.</li> <li>2. Main contactor missing.</li> <li>3. Wire to main contactor open.</li> </ol>	Check wiring and cycle KSI.





# T15 Propel Controller

(page 3 of 3)

## PROPEL CONTROLLER TROUBLESHOOTING CHART, cont'd

LED CODE	PROGRAMMER LCD DISPLAY	FAULT CATEGORY	POSSIBLE CAUSE	FAULT CLEARANCE
4,1	LOW BATTERY VOLTAGE	2	1. Battery voltage < undervoltage cutback. 2. Corroded battery terminal. 3. Loose battery or controller terminal.	When voltage rises above undervoltage cutoff point.
4,2	OVERVOLTAGE	2	1. Battery voltage > overvoltage shutdown limit. 2. Vehicle operating with charger attached.	When voltage falls below overvoltage cutoff point.
4,3	THERMAL CUTBACK	2	1. Temperature >85°C or < -25°C. 2. Excessive load on vehicle. 3. Improper mounting of controller.	Clears when heatsink temperature returns to within acceptable range.
4,4	ANTI-TIEDOWN	3	1. Mode switches shorted to B+. 2. Mode Select 1 "tied down" to select Mode 2 or Mode 4 permanently.	Release Mode Select 1.
	MOTOR HOT	3	1. Field resistance > motor hot setpoint.	When resistance < setpoint.
	MOTOR WARM	3	1. Field resistance > motor warm setpoint.	When resistance < setpoint.

## PROPEL CONTROLLER STATUS LED FAULT CODES

LED CODES		EXPLANATION
<i>LED off</i>		no power or defective controller
<i>solid on</i>		controller or microprocessor fault
0,1	■ □	controller operational; no faults
1,1	□ □	current sensor error
1,2	□ □□	hardware failsafe fault
1,3	□ □□□	M- fault or motor output short
1,4	□ □□□□	static return to off (SRO)
2,1	□□ □	throttle wiper high
2,2	□□ □□	emergency reverse circuit check fault
2,3	□□ □□□	high pedal disable (HPD), or expired timer
2,4	□□ □□□□	throttle wiper low
3,1	□□□ □	contactor driver overcurrent or field winding short
3,2	□□□ □□	main contactor welded
3,3	□□□ □□□	field winding open
3,4	□□□ □□□□	missing contactor
4,1	□□□□ □	low battery voltage
4,2	□□□□ □□	overvoltage
4,3	□□□□ □□□	thermal cutback, due to over/under temp
4,4	□□□□ □□□□	anti-tiedown fault, or overheated motor



# T15 Operating Lights (option)

Conditions: Key ON

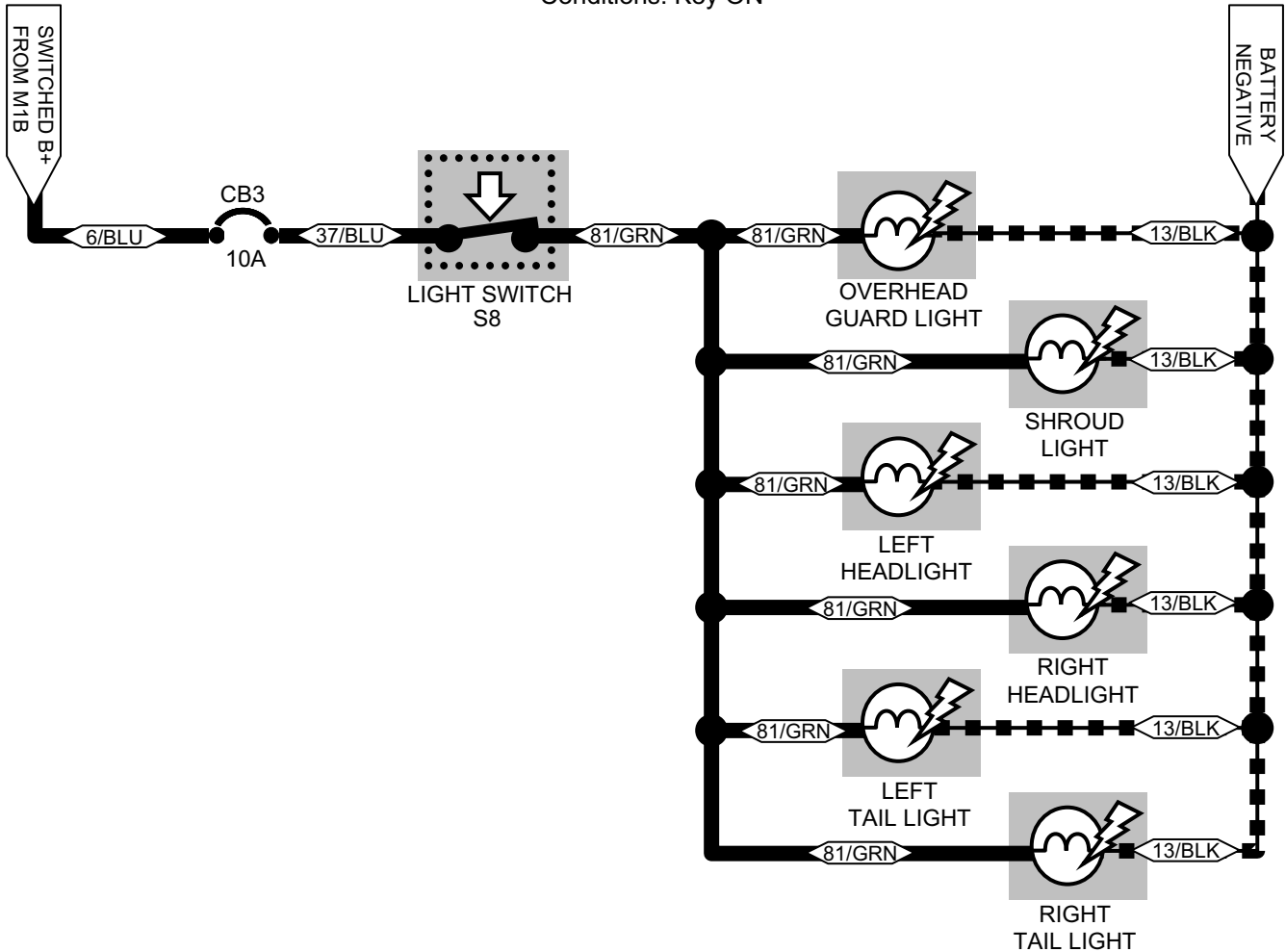

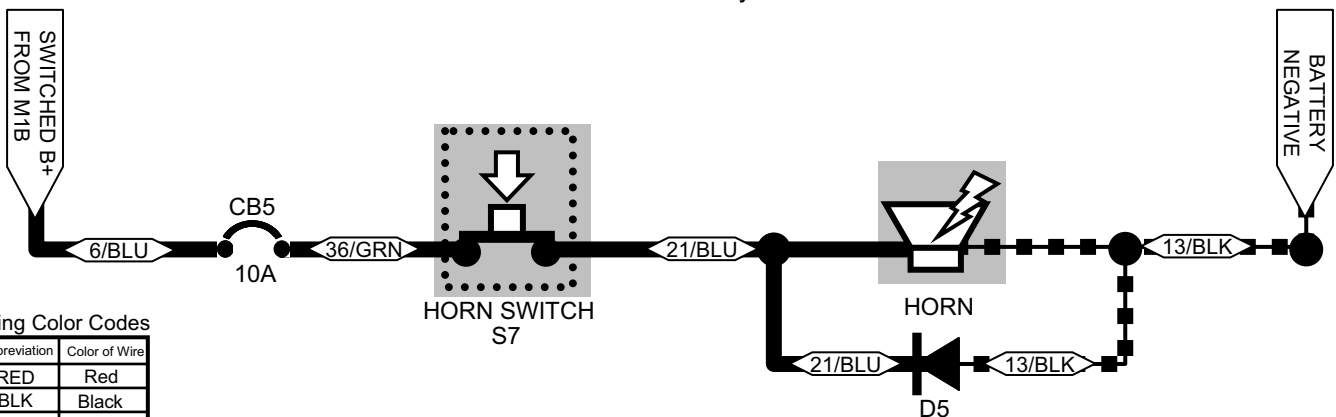

# T15 Horn ON

Conditions: Key ON



### Wiring Color Codes

Abbreviation	Color of Wire
RED	Red
BLK	Black
WHT	White
GRY	Gray
BRN	Brown
PNK	Pink
ORA	Orange
YEL	Yellow
GRN	Green
BLU	Blue
PUR	Purple
CLR	Clear

 = Battery Negative or Logic Ground  
 = Battery Positive or Positive Output

**Be cautious when working near Control Board - *Battery voltage is always present, even with Key OFF***



# T15 Extended Scrub (ES) System ON (option)

Conditions: Key ON, scrubbing system ON, ES system ON, recovery tank HALF FULL or more, solution tank NOT FULL

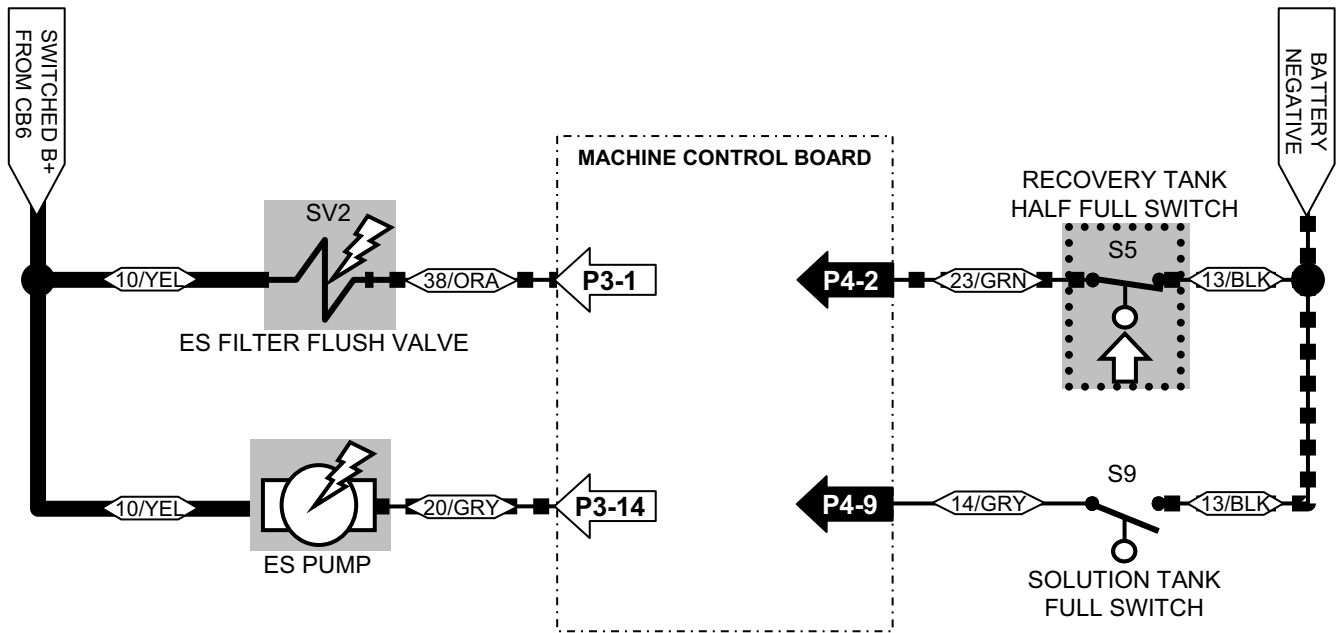

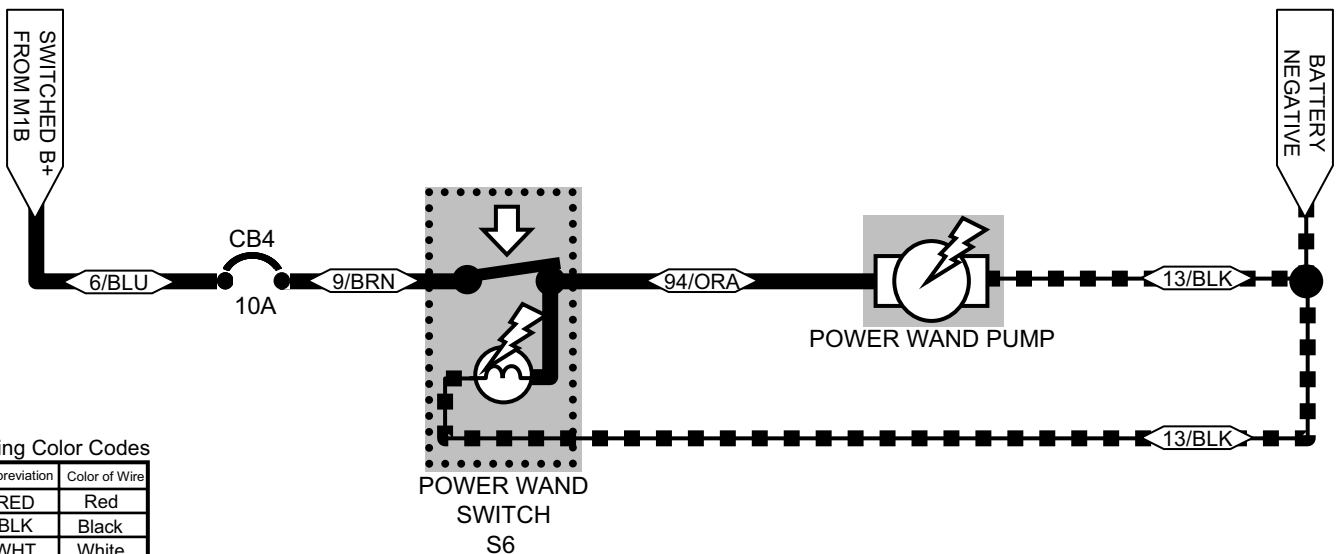

# T15 Power Wand ON (option)

Conditions: Key ON



### Wiring Color Codes

Abbreviation	Color of Wire
RED	Red
BLK	Black
WHT	White
GRY	Gray
BRN	Brown
PNK	Pink
ORA	Orange
YEL	Yellow
GRN	Green
BLU	Blue
PUR	Purple
CLR	Clear

 = Battery Negative or Logic Ground  
 = Battery Positive or Positive Output

**Be cautious when working near Control Board - *Battery voltage is always present, even with Key OFF***

# T15 ES System Troubleshooting

**OPERATION: When ES system selected on the touch panel and input floats are in the proper position**

- Recovery tank is 1/2 full = S-5 is closed
- Solution tank NOT full = S-9 is opened
- P3-14 is switched to ground, turning on the ES pump

NOTE: Once ES pump is turned on, it will keep running until S-5 opens, plus 30 seconds or until S-9 closes = solution tank full

\* MACHINE POWERS UP, TOUCH PANEL AND PROPEL SYSTEMS TEST GOOD

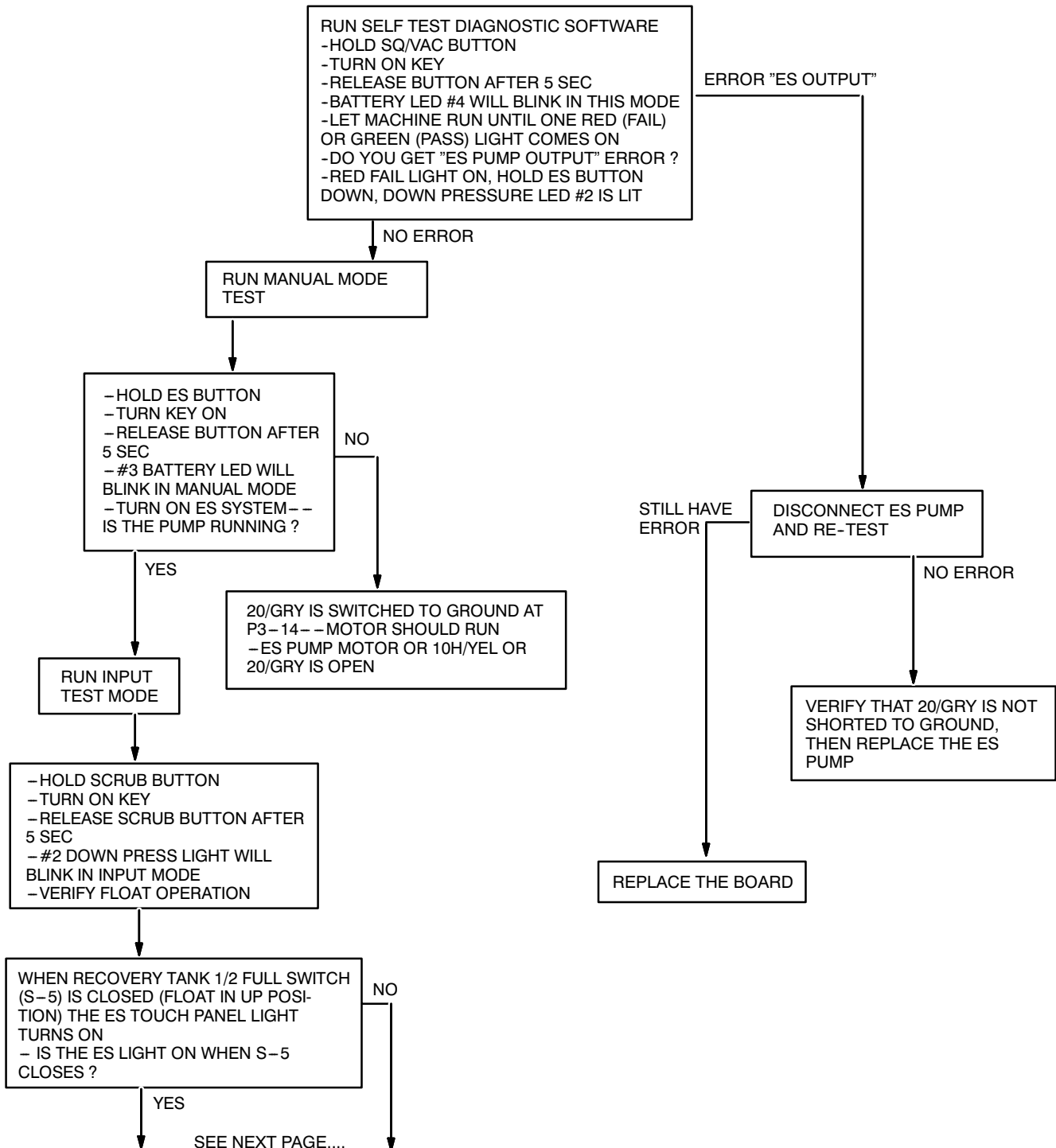

# T15 ES System Troubleshooting (cont'd)

CONTINUED FROM PREVIOUS PAGE

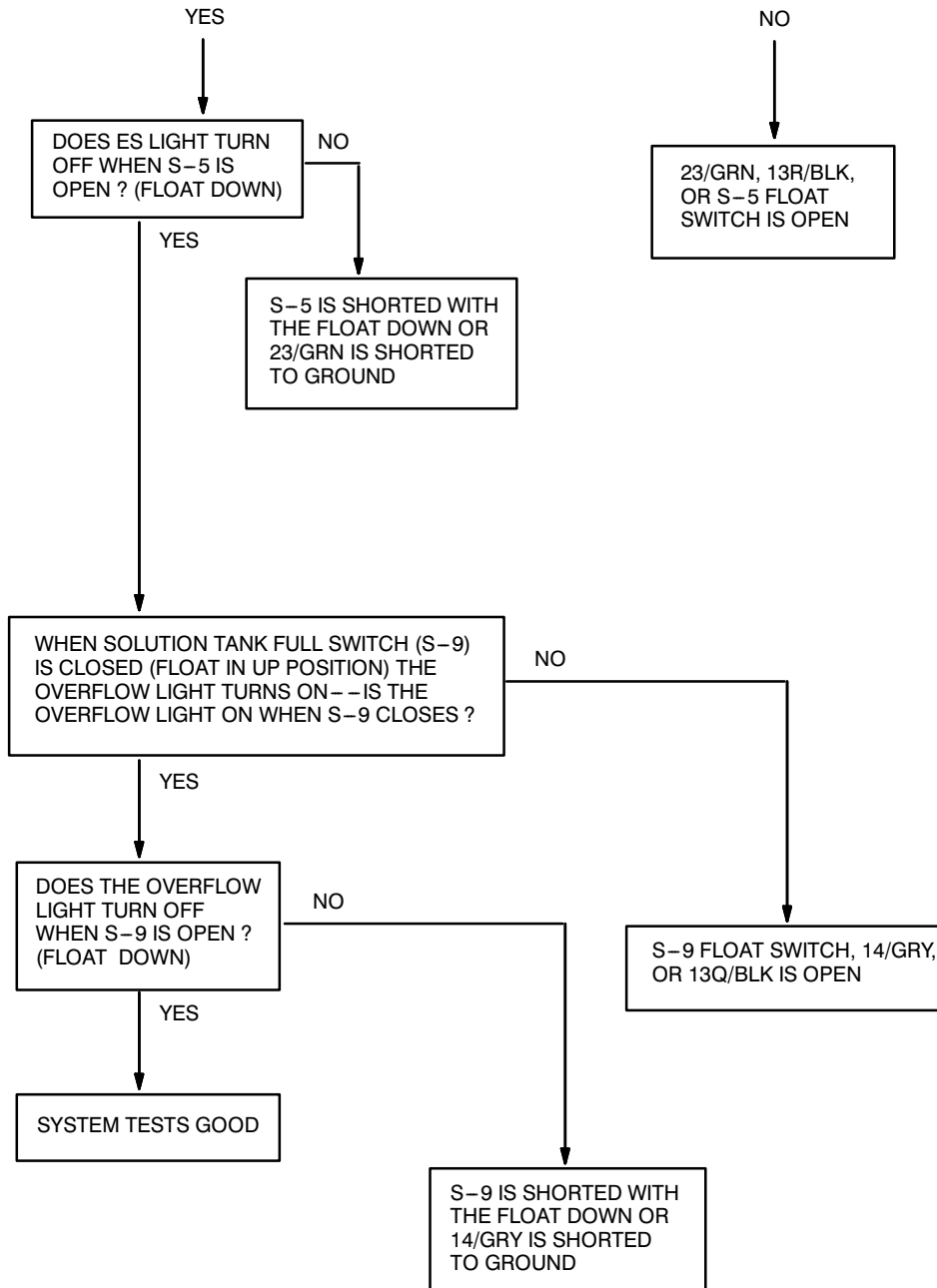

# T15 ES Filter Flush Troubleshooting

**OPERATION: To enable the ES™ flush system--the vacuum fan and ES™ system must be turned on**

- P3-1 will switch to ground for 5 seconds every 45 seconds--turning on SV-2
- Every time SV-2 is turned on an air burst clears debris from the ES™ pump filter

\* MACHINE POWERS UP, TOUCH PANEL AND PROPEL SYSTEMS TEST GOOD

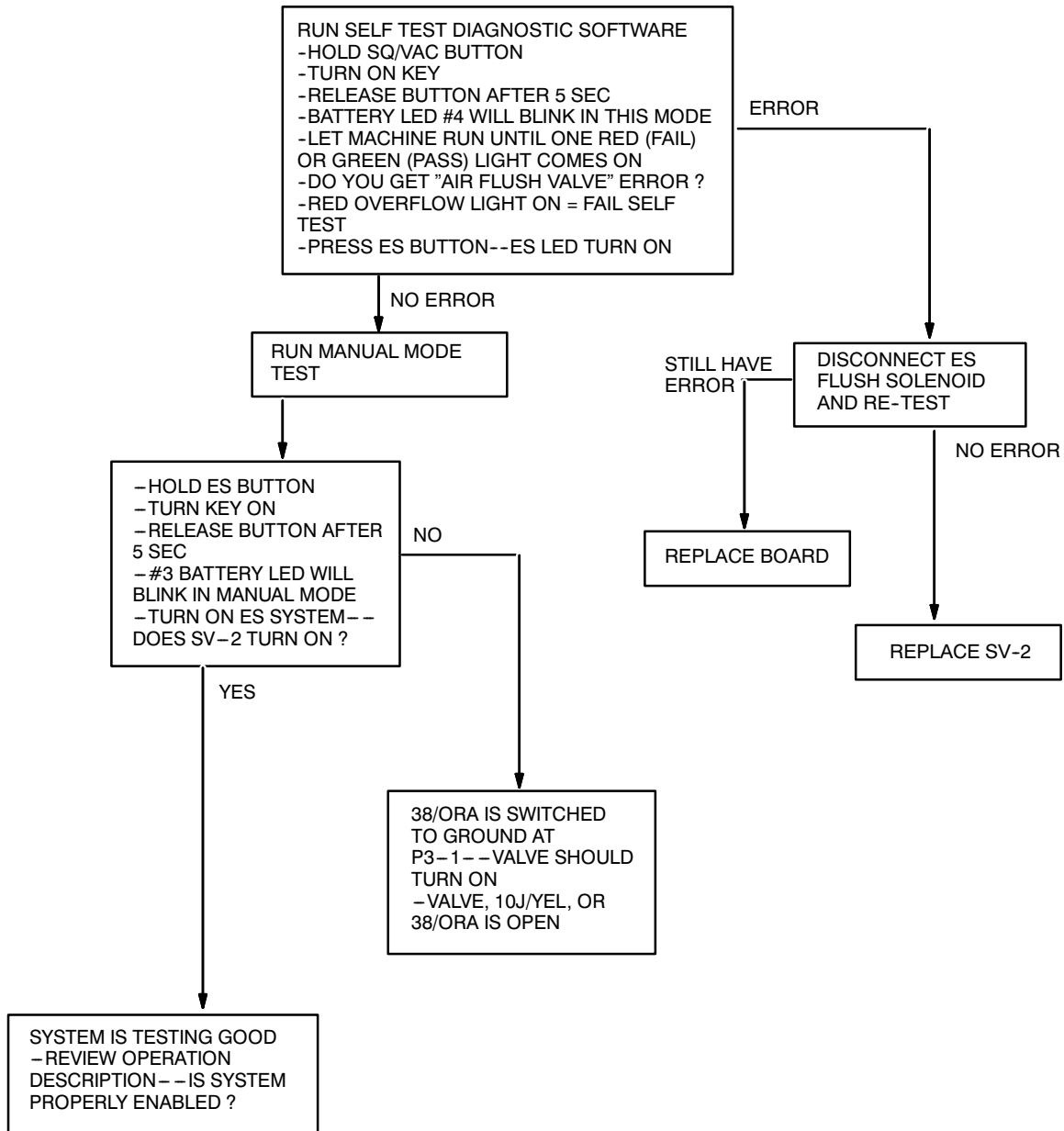

# T15 Pre-Sweep System ON (option)

Conditions: Key ON, sweeping system ON, propel forward

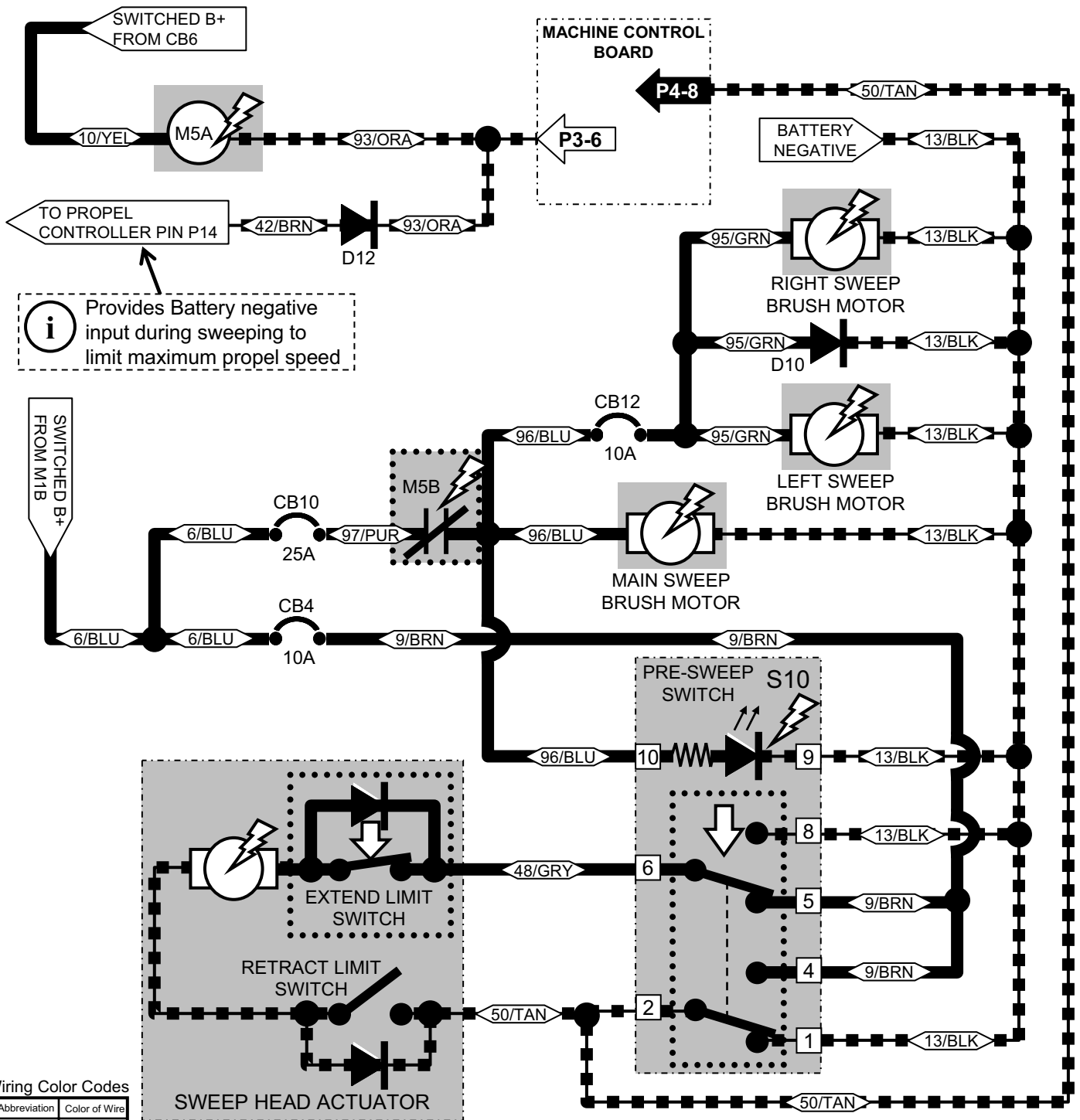

**i** Provides Battery negative input during sweeping to limit maximum propel speed



### Wiring Color Codes

Abbreviation	Color of Wire
RED	Red
BLK	Black
WHT	White
GRY	Gray
BRN	Brown
PNK	Pink
ORA	Orange
YEL	Yellow
GRN	Green
BLU	Blue
PUR	Purple
CLR	Clear

= Battery Negative or Logic Ground  
 = Battery Positive or Positive Output

- i**
- This diagram shows the Sweep Head Actuator being extended and how it receives Battery negative before the Retract Limit Switch closes
  - The Retract Limit Switch will close shortly after the actuator begins to extend
  - The Extend Limit Switch will open when the actuator reaches the end of travel

**⚠ Be cautious when working near Control Board - Battery voltage is always present, even with Key OFF**

# T15 Pre-Sweep Dust Control ON (option)

Conditions: Key ON, sweeping system ON, propel forward

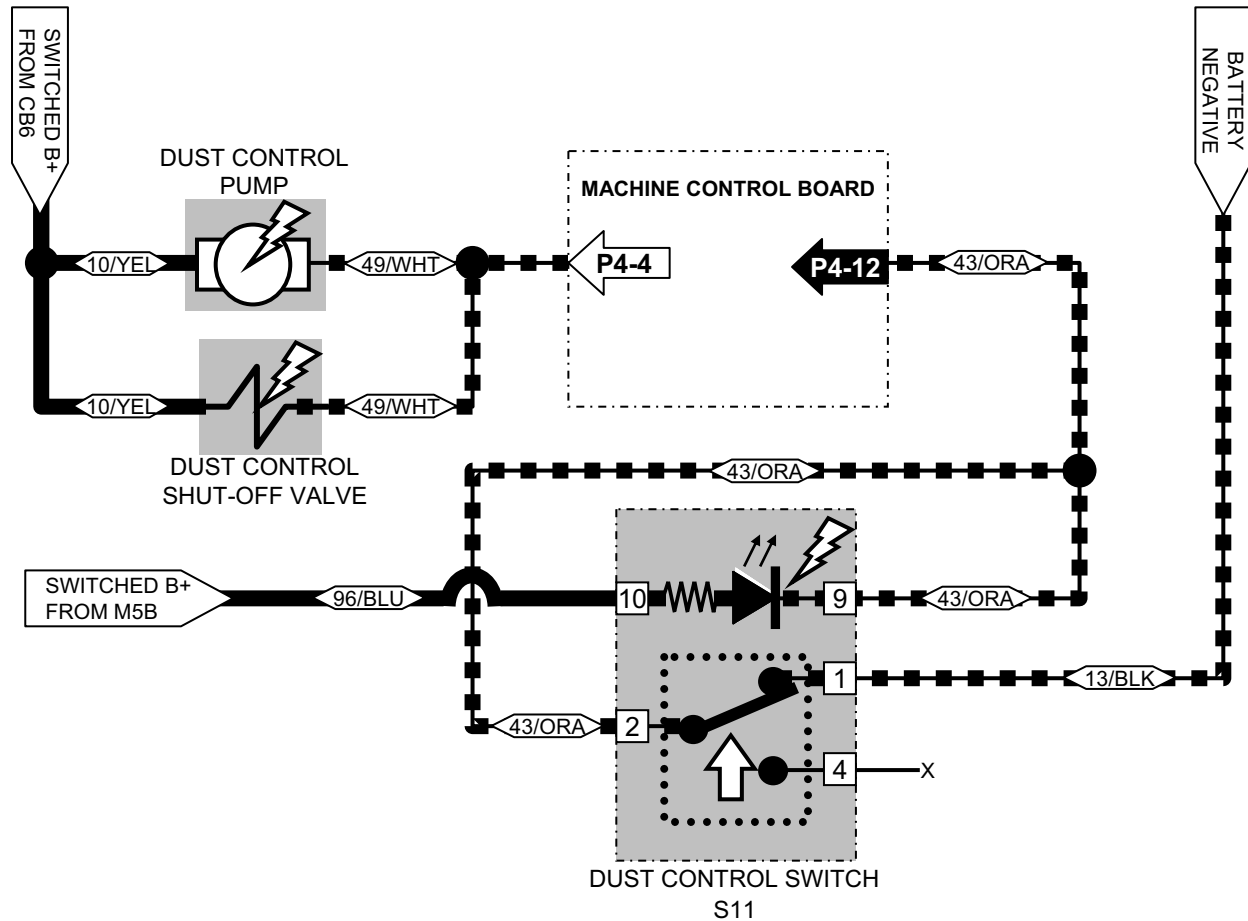

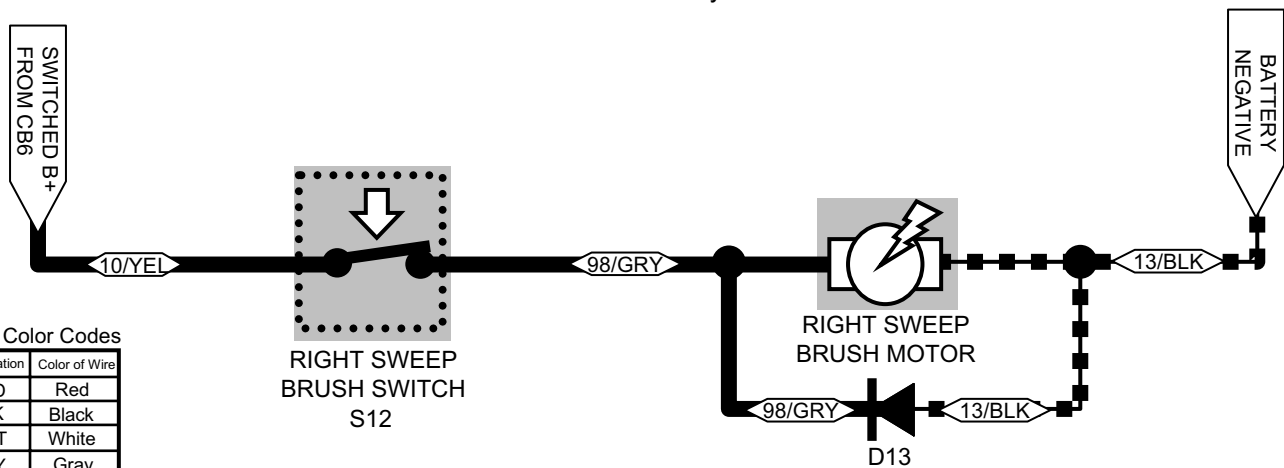

# T15 Right Sweep Brush ON (option – Cylindrical Scrub Head ONLY, NO Pre-Sweep)

Conditions: Key ON



### Wiring Color Codes

Abbreviation	Color of Wire
RED	Red
BLK	Black
WHT	White
GRY	Gray
BRN	Brown
PNK	Pink
ORA	Orange
YEL	Yellow
GRN	Green
BLU	Blue
PUR	Purple
CLR	Clear

 = Battery Negative or Logic Ground  
 = Battery Positive or Positive Output

**Be cautious when working near Control Board - *Battery voltage is always present, even with Key OFF***

# T15 FaST System ON

Conditions: Key ON, scrubbing system ON, operator on seat, propel forward, recovery tank NOT FULL

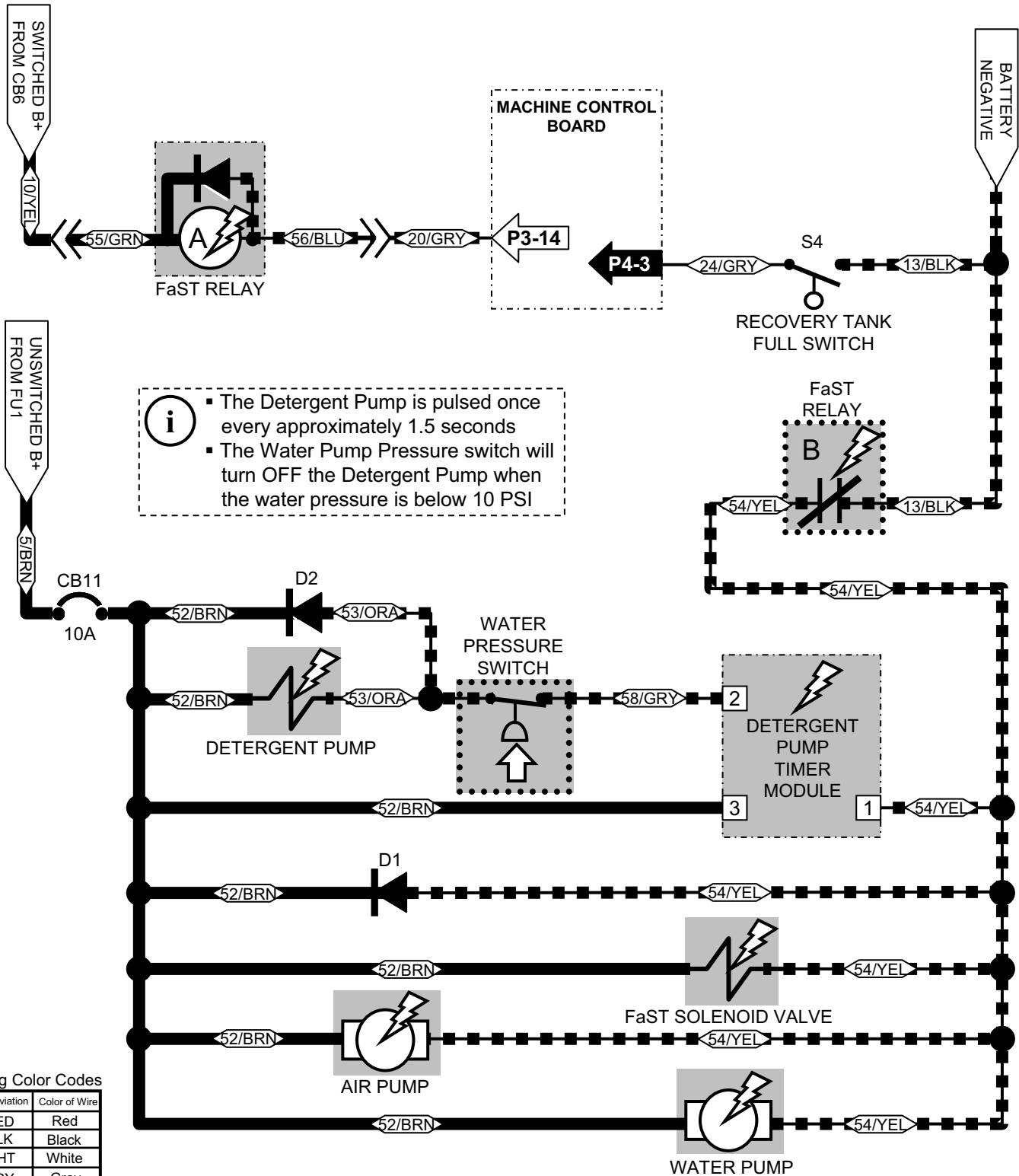

**i**

- The Detergent Pump is pulsed once every approximately 1.5 seconds
- The Water Pump Pressure switch will turn OFF the Detergent Pump when the water pressure is below 10 PSI

### Wiring Color Codes

Abbreviation	Color of Wire
RED	Red
BLK	Black
WHT	White
GRY	Gray
BRN	Brown
PNK	Pink
ORA	Orange
YEL	Yellow
GRN	Green
BLU	Blue
PUR	Purple
CLR	Clear

= Battery Negative or Logic Ground  
 = Battery Positive or Positive Output

**⚠ Be cautious when working near Control Board - Battery voltage is always present, even with Key OFF**



# T15 Battery Charger Troubleshooting

(Page 1 of 5)



## Battery Charger Troubleshooting Guide (Single LED Model)

Delta-Q's QuiQ charger is designed for a long, trouble-free service life. Occasionally, the user may encounter abnormal operation which can usually be corrected by following the procedures in this guide.

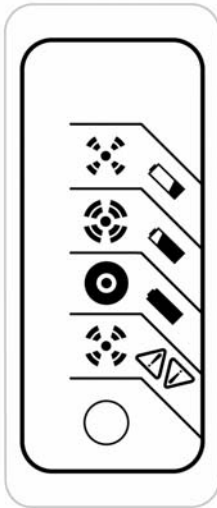
### Indications on the Charger Single-LED Display (internal or external)



LED indications following "Power-On Self Test":

<b>Green</b>		<b>Solid:</b>	Charging complete. Charger in Maintenance Mode.
		<b>Flashing:</b>	<i>Short:</i> <80% Charge. <i>Long:</i> >80% Charge. <i>When battery is not connected (flashes with 1.5 to 2 second pauses):</i> Algorithm Number display.
<b>Amber</b>		<b>Flashing:</b>	Reduced Power Mode: Low AC Voltage or High internal charger temperature. <ul style="list-style-type: none"><li>• Provide better airflow to the charger.</li><li>• Try to move the charger to a cooler location.</li><li>• Confirm that dirt or mud is not blocking the cooling fins of the charger. Clean the charger. Rinse charger with low pressure hose if required. Do not use high pressure. Do not use a pressure washer.</li></ul>
<b>Red</b>		<b>Flashing:</b>	Charger error. Check code and refer to troubleshooting guide below.



# T15 Battery Charger Troubleshooting

(Page 2 of 5)

## Fault Indications:

### Fault LED

#### Flashes (Red)

#### Explanation and Solution



High Battery Voltage Detected

- Check that the battery charger voltage is consistent with the battery pack voltage. The first two digits of the four digit model name indicate the battery voltage the charger supports.
- Check for wiring errors.
- High battery voltage could also occur if there is another source charging the battery. Disconnect any other sources during charging.
- If this problem does not clear after the battery voltage is confirmed to be less than 2.4V per cell, return the charger for service.
- This fault will automatically clear and the charger will restart charging when this problem is removed.

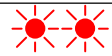

Low Battery Voltage Detected

- Check the battery and connections to the battery.
- Check the nominal battery voltage. The first two digits of the four digit model name indicate the battery voltage the charger supports. Confirm that a nominal battery voltage is the same as the charger voltage.
- If this problem does not clear after the battery voltage is confirmed to be higher than 1V per cell and all connections are good, return the charger for service.
- This fault will clear automatically when the low battery voltage problem is rectified.

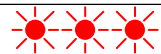

Charge Timeout - Indicates the battery failed to charge within the allowed time. This could occur if the battery is of larger capacity than the algorithm is intended for. In unusual cases it could mean charger output is reduced due to high ambient temperature. It can also occur if the battery is damaged, old, or in poor condition.

- Check the battery for damage such as shorted cells and insufficient water. Try the charger on a good battery.
- If the same fault occurs on a good battery, check the connections on the battery and connection to AC power, and AC voltage.
- Confirm that the nominal battery pack voltage is the same as the battery charger voltage.
- If a charger displays this fault on a battery pack, and the pack is of questionable status, reset the charger by disconnecting AC power for 30 seconds, and then reconnect the AC to start a new charge cycle. After a few charge cycles this problem could stop occurring as the pack "recovers."
- This fault must be cleared manually by unplugging the AC, waiting 30 seconds and reconnecting the ac power.

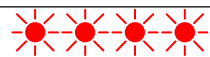

Check Battery - This fault indicates the battery pack could not be trickle charged up to the minimum level required for the normal charge cycle to be started.

- Check that none of the battery pack connections between modules are reversed or incorrectly connected.
- Check that one or more cells in the battery are not shorted.
- Confirm that the nominal battery pack voltage is the same as the battery charger voltage.



# T15 Battery Charger Troubleshooting

(Page 3 of 5)

- Try the charger on a good battery.
- If this fault occurs the battery pack is likely in poor condition. Try to recover the pack with a charger that can charge the individual cells – such as an automotive charger. Be sure to set this charger to the appropriate voltage – 6V per 6V battery, 12V per 12V string/battery.

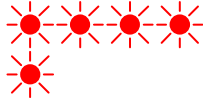

**Over-Temperature:** This fault indicates the charger has become too hot during operation. This extra fault indication (as opposed to the flashing LED described above), indicates an even higher temperature was reached inside the charger. Though not damaging to the charger, charge time will be extended significantly

- This fault indication will not clear automatically, but the charger will restart charging automatically when the temperature drops. The fault indication must be cleared manually by unplugging the AC power, waiting 30 seconds and reconnecting the AC.
- If possible, install the charger in a cooler location or increase cooling air flow to the cooling fins.
- Confirm that dirt or mud is not blocking the cooling fins of the charger. If required, clean the charger by rinsing it with a low pressure hose. Do not use high pressure. Do not use a pressure washer.

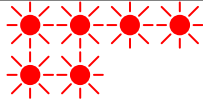

**QuiQ Internal Fault:** This fault indicates that the batteries will not accept charge current, or an internal fault has been detected in the charger. This fault will nearly always be set within the first 30 seconds of operation. If it occurs after the charger has started charging normally, be sure to make a note of it.

- Try to clear the fault by unplugging AC power, waiting 30 seconds and reconnecting the AC.
- Check all battery connections. Look for a high resistance connection. The most likely reason for this fault is a fault in the battery such as a bad battery connection, an open cell, or insufficient water.
- This fault will occur if an internal fuse inside the charger blows. If the green wire is shorted to ground even momentarily this fuse will blow. To check the fuse, measure with an ohmmeter between the green and red wires with the AC disconnected. If a short circuit is not measured, the fuse has blown. Return unit to a service depot to have this fuse replaced.
- For software revision 0.81 or older, this fault may indicate that the input or output voltage went out of range. Check input and output connections before returning the unit to a service depot. Charger may need to be brought to a service depot to have its software upgraded. Refer to the lower right hand corner on the back of the Product Manual to determine the software revision.
- If this fault occurs after battery charging has started, confirm that AC power was not interrupted and that all battery connections are good.
- If all battery connections are good, an internal fault has been detected and the charger must be brought to a qualified service depot.

## Other Indications:

Indication	Explanation and Solution
AC On LED Lit, Charger won't start charging.	Charger has detected a condition that does not allow it to charge

# T15 Battery Charger Troubleshooting

(Page 4 of 5)

- Confirm battery connections are good.
- The nominal voltage for a lead acid battery is 2 V per cell. For example, a 48V battery will have  $48/2 = 24$  cells.
- If the battery voltage is greater than 2.5V per cell, the charger will not start charging.
- If the battery voltage is less than 0.5V per cell, the charger will not start.
- For software revisions 0.81 or lower, the charger will not start charging if the battery voltage is less than 1V per cell. Refer to the lower right hand corner of the back of the Product Manual to determine the software revision.
- Check for any fault codes that might be set and refer to the descriptions above.
- A fully charged battery will draw very little current, but will not show 100% charged immediately. The charger will change to Absorption mode in under 5 minutes once the conditions for the end of bulk charge have been met. The 80% LED will illuminate at this time. During the final phase of charging, the battery will only accept a very small current – the charger is unable to accelerate this portion of the charge cycle without damaging the battery.

---

**Excessive Battery Watering or Strong Sulphur (Rotten Egg) Smell**

Overcharging or high battery temperature. These symptoms are unlikely to be caused by too high a charge current since the maximum charge current of the charger will be small compared to even a moderately sized battery pack. The most likely cause for this problem is incorrect charge algorithm setting and/or high ambient temperatures.

- Confirm that the battery pack is not too small – usually > 50Ah.
- Confirm that the nominal battery voltage matches the charger output voltage.
- Confirm the correct battery charge algorithm. If the battery pack is new, the algorithm will need to be changed if the pack is not the same as the old one. Refer to the Product Manual for instructions on how to determine and change the battery charge algorithm.
- If the output voltage of the charger seems excessive, return the charger for service. Contact Delta-Q to get the expected battery voltage settings for the charger in question. Be sure to have the charger's serial number and charge algorithm setting available when calling.

---

**Difficulty Changing the Default Battery Charge Algorithm**

The mode to change the battery charge algorithm can only be selected during the first 10 seconds of operation. Refer to the Product Manual for instructions.

If the 10 second window is missed, cycle AC power by unplugging the charger, waiting 30 seconds, and reconnecting AC power.

To extend Battery Charge Algorithm Change Mode by 30 seconds (120 seconds on newer models), connect the charger output to a good battery for approximately 1 second and then disconnect the battery again.

## General Troubleshooting

Should the condition of a charger be in doubt, the flow chart on the next page should be followed to check the charger's operating condition.



# T15 Battery Charger Troubleshooting

(Page 5 of 5)

## Delta-Q Technologies QuiQ Charger Troubleshooting Flow Chart

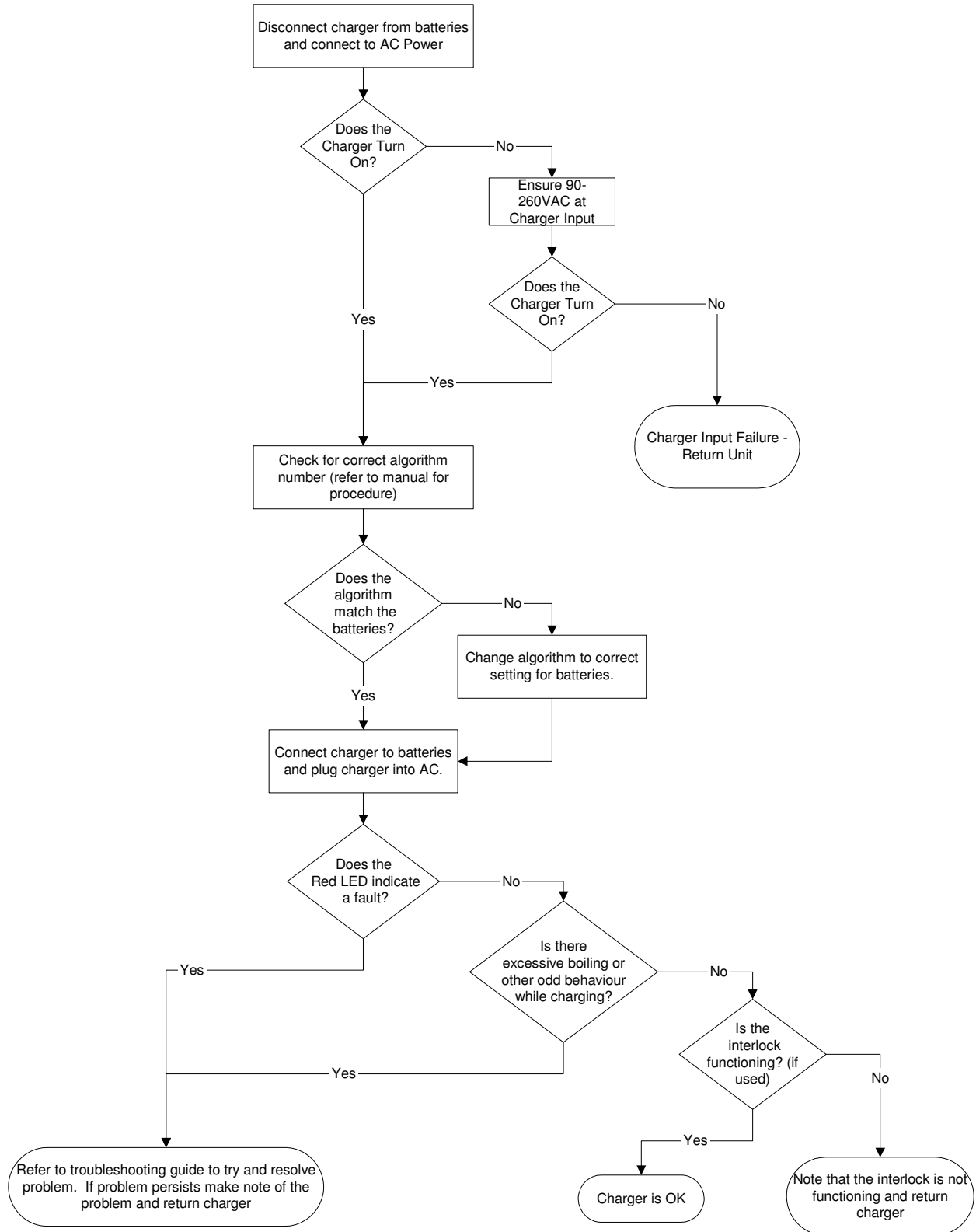

# T15 Machine Control Board Connectors

## 15 PIN CONNECTOR (P3)

pin #	wire #	color	input or output	active voltage	inactive voltage	function/component controlled
1	38	orange	output	B-	B+	SV2 ES filter flush solenoid
2	10	yellow	input	B+	open	x 36 VDC power
3	13	black	input	B-	x	x Power ground
4	18	brown	output	B+ or B-	open	ACT2 Scrub head actuator
5	19	green	output	B+ or B-	open	ACT2 Scrub head actuator
6	93	orange	output	B-	B+	M5A Sweeper system relay
7	10	yellow	input	B+	open	x 36 VDC power
8	13	black	input	B-	x	x Power ground
9	41	blue	output	B-	B+	x Hour meter
10	16	yellow	output	B+ or B-	open	ACT1 Squeegee actuator
11	12	green	output	B-	B+	M3A Main brush motors relay
12	11	brown	output	B-	B+	M2A Vacuum fan(s) relay
13	15	purple	output	B-	B+	SV1 Conventional solenoid valve
14	20	gray	output	B-	B+	x ES pump or FaST system
15	17	gray	output	B+ or B-	open	ACT1 Squeegee actuator

# P3

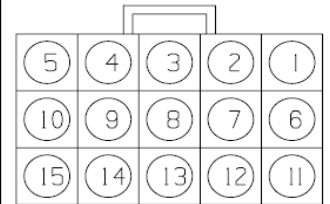

**i** Viewed from the wire side of harness connector

## 12 PIN CONNECTOR (P4)

pin #	wire #	color	input or output	active voltage	inactive voltage	function/component controlled
1	10	yellow	input	B+	open	x 36 VDC power
2	23	green	input	B-	open	S5 Recovery tank half full switch
3	24	gray	input	B-	open	S4 Recovery tank full switch
4	49	white	output	B-	B+	SV1 Sweeper dust control system
5	13	black	input	B-	x	x Control ground
6	28	brown	input	B+	open	x Forward propel signal
7	29	gray	input	B+	open	x Reverse propel signal
8	50	tan	input	B-	B+	S10 Sweeper switch
9	14	gray	input	B-	open	S9 Solution tank full switch
10	22	brown	input	B-	open	x Brush motor fault signal
11	25	gray	input	B+	x	x Battery sense
12	43	orange	input	B-	open	S11 Dust control switch

# P4

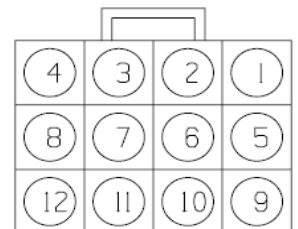

**i** Viewed from the wire side of harness connector

## 3 PIN CONNECTOR (P5)

pin #	wire #	color	input or output	function/component controlled
1	13	black	input	Cable shield (noise suppression)
2	87	clear	input	Brush motors shunt LOW
3	88	black	input	Brush motors shunt HIGH

# P5



**i** Viewed from the wire side of harness connector

# T15 Propel Controller Connectors

## 16 PIN CONNECTOR

pin #	wire #	color	input or output	active voltage	inactive voltage	function/component controlled
1	empty	x	x	x	x	
2	empty	x	x	x	x	
3	empty	x	x	x	x	
4	empty	x	x	x	x	
5	empty	x	x	x	x	
6	31	yellow	input	0 to 5 VDC	open	Throttle position signal
7	empty	x	x	x	x	
8	66	blue	output	B-	B+	Electric solenoid brake
9	27	green	input	B+	B-	Mode select
10	empty	x	x	x	x	
11	29	gray	input	B+	B-	Reverse propel signal
12	28	brown	input	B+	open	Forward propel signal
13	empty	x	x	x	x	
14	42	brown	input	B-	open	Low speed enable signal
15	98	gray	input	B+	open	Brake & seat switch interlock
16	27	green	input	B+	B-	Key switch signal

## 4 PIN CONNECTOR

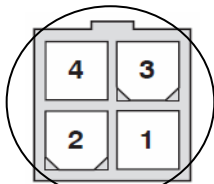

**i** 4 Pin Connector not used (for programming only)

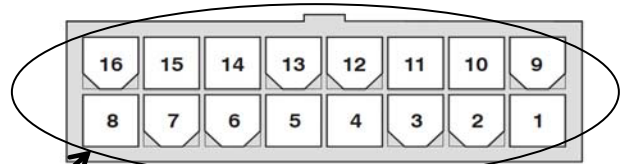

## 16 PIN CONNECTOR

**i** Viewed from the wire side of harness connector

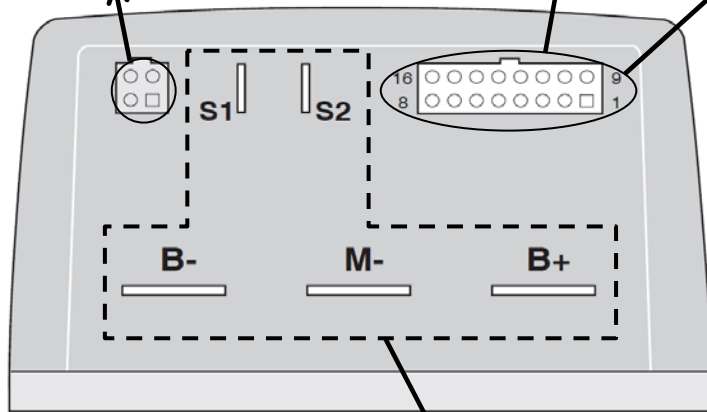

CURTIS 1243 PROPEL CONTROLLER

pin #	input or output	active voltage	inactive voltage	function/component controlled
B+	input	B+	open	36 VDC power
B-	input	B-	x	Power ground
M-	output	B-	open	Propel motor armature power
S1	output	B- to B+	open	Propel motor field power
S2	output	B- to B+	open	Propel motor field power

# T15 Operating & Configuration Modes

(Page 1 of 12)

Configuration modes are designed for use by a technician for setup purposes.

Mode	Entry Sequence / Indicator	Function / Notes
<b>NORMAL MODE</b>	1) Turn key switch to the start position, then release key.	Default mode for general operation of machine.
<b>SELF TEST MODE</b>	1) Press and hold the "Squeegee/Vacuum Fan" button. 2) Turn key switch to the start position, then release key. 3) Hold "Squeegee/Vacuum Fan" button for 5 seconds. 4) Release the "Squeegee/Vacuum Fan" button. Battery LED # 4 will flash.	Tests the operation of the Machine Control Board and exercises all of its outputs. When this mode is engaged, various motors and accessories will be engaged at full power as part of the test. Extreme care must be taken to be sure that technicians and bystanders are not injured as a result of this test.
<b>MANUAL MODE</b>	1) Press and hold the "ES" or "FaST" button. 2) Turn key switch to the start position, then release key. 3) Hold "ES" or "FaST" button for 5 seconds. 4) Release the "ES" or "FaST" button. Battery LED # 3 will flash.	Allows the technician to exercise individual functions on the machine. This mode disregards the effects of various interlocks. <b>DO NOT</b> scrub with the machine in this mode.
<b>INPUT DISPLAY MODE</b>	1) Press and hold the "Scrub" button. 2) Turn key switch to the start position, then release key. 3) Hold "Scrub" button for 5 seconds. 4) Release the "Scrub" button. Battery LED # 2 will flash.	Allows the technician to observe the effectiveness of various inputs and sensors on the machine controller board. When in this mode, the technician can scrub with the machine as normal and observe the operation of the various inputs.
<b>RESTRICTED DOWN PRESSURE MODE</b>	1) Press and hold both the "Squeegee/Vacuum Fan" and "Scrub" buttons. 2) Turn key switch to the start position, then release key. 3) Hold "Squeegee/Vacuum Fan" and "Scrub" buttons until three <b>OR</b> four brush pressure LED's start flashing. 4) Release the "Squeegee/Vacuum Fan" and "Scrub" buttons and turn key switch OFF. The mode has now been toggled.	Toggles the machine between normal and a restricted down pressure setting. The normal mode allows all four down pressure LED settings. The restricted mode allows only three LED settings. Each time the Restricted Down Pressure Mode is entered, the machine will toggle between normal and restricted down pressure modes.
<b>SOFTWARE REVISION DATE DISPLAY MODE</b>	1) Press and hold both the "Squeegee/Vacuum Fan" and "ES/FaST" buttons. 2) Turn key switch to the start position, then release key. 3) Hold "Squeegee/Vacuum Fan" and "ES/FaST" buttons until the ES/FaST LED begins to flash. 4) Release the "Squeegee/Vacuum Fan" and "ES/FaST" buttons. The software revision date will be flashed on the touch panel. 5) The flashing sequence will continue until the key switch is turned OFF.	Displays the machine's software revision date. Each sequence of flashes is separated by a pause, then repeated over and over until the key switch is turned OFF.  The <b>MONTH</b> is displayed by the number of flashes of the "ES" or "FaST" LED.  The <b>DAY</b> is displayed by the number of flashes of the "Squeegee/Vacuum Fan" LED.  The <b>YEAR</b> is displayed by the number of flashes of the "Recovery Tank Full" LED.



# T15 Operating & Configuration Modes

(Page 2 of 12)

Mode	Entry Sequence / Indicator	Function / Notes
<b>NORMAL MODE</b>	1) Turn key switch to the start position, then release key.	Default mode for general operation of machine.

## **NORMAL MODE**

The purpose of the normal mode is for the general operation of the machine. The machine will normally start in this mode. What follows is a brief description of each of the operations in the normal mode.

### **SCRUB BUTTON**

The purpose of the scrub button is to turn the scrubbing operations on and off and adjust the scrubbing down pressure. Pressing the scrub button while the scrubbing operation is currently inactive will initiate the following actions:

1. Illuminate the LED's that indicate the default down pressure. Note: Hold the scrub button down to get another down pressure setting. See item 4 below.
2. If the machine is not in reverse, the vacuum fan will turn on, the squeegee will drop, and the brushes will drop. Putting the machine into reverse will raise the squeegee and, after a slight delay, turn off the vacuum fan.
3. If the machine is in forward, the brush head will drop, water valve will turn on, and the brushes will start turning. Putting the machine into neutral while scrubbing will turn off the brushes and, after a short delay, slightly raise the scrub head.
4. If the operator holds the scrub button after the LED's become illuminated, the machine will begin to scroll through the different scrub down pressures. The controller stores the pressure displayed as the new default after the user releases the scrub button.

Pressing and releasing the scrub button while the machine is currently in the scrub mode will initiate the following actions:

1. The scrub motors will turn off and the scrub head will start to raise.
2. The machine will delay a few seconds and the squeegee will start to raise.
3. The vacuum fan will turn off after a slight delay.

### **SQUEEGEE/VACUUM FAN BUTTON**

Pressing the squeegee button will start or stop the water pickup operation. If the operator presses the Squeegee/Vacuum Fan button while the squeegee LED is currently not illuminated will cause the following actions:

1. The squeegee LED will be illuminated.
2. If the machine is not in reverse, the squeegee will drop and the vacuum fan will turn ON. If the machine goes into reverse while the squeegee/vacuum fan is active, the squeegee will rise. If the machine remains in reverse long enough, the vacuum fan will shut OFF. Pressing the squeegee button while the Squeegee/Vacuum Fan LED is on will cause the Squeegee/Vacuum Fan LED to turn OFF, raise the squeegee, and turn off the vacuum fan after a slight delay.

### **ES BUTTON**

Pressing the ES button will enable or disable the ES system. The ES system will draw water from the recovery tank, through a filter and pump it into the solution tank. If the operator has turned on the ES system, and the recovery tank is at least half full (switch S5 is closed), and the solution tank is not full (switch S9 is open), the ES pump will begin to run. The ES pump will continue to run for about 30 seconds after the recovery tank is less than half full (switch S5 is open).

### **HOUR METER**

The Hour Meter will record hours if the machine:

1. Is PROPELLING forward or reverse.
2. The VACUUM FAN(S) are running.



# T15 Operating & Configuration Modes

(Page 3 of 12)

## **NORMAL MODE** (continued)

### **BATTERY GAUGE**

The battery gauge displays the state of charge of the batteries with a 4 segment LED display. When the last segment is blinking, the battery voltage is about 31.5 volts (80% discharge), and the batteries need charging. The scrub and squeegee/vacuum fan functions will shut off if the operator is scrubbing at this point. If the user selects the squeegee button, the squeegee will lower, and the vacuum fan will run for about 30 seconds to allow the operator to pick up any excess water. The squeegee will then lift, and the vacuum fan will shut off after a slight delay.

### **INTERLOCKS**

The machine has several interlocks which can inhibit or cancel machine functions.

**REVERSE** - When the operator propels in reverse with the squeegee/vacuum fan system ON the SQUEEGEE will lift and the VACUUM FAN will turn off after a time delay (the vacuum fan function will resume when in neutral or forward propel).

**NEUTRAL** - When the operator stops propelling (machine in neutral) with the scrub system active, the scrub system will remain ON for 5 seconds. After the 5 second delay, the CONVENTIONAL WATER VALVE or FaST system and SCRUB BRUSHES will turn OFF, and the SCRUB HEAD will raise slightly.

**LOW BATTERY** - When the last battery LED is blinking (about 31.5 volts), the machine will cancel the SCRUB FUNCTIONS (the scrub functions will cancel as if the scrub button was toggled). The operator cannot restart the scrub functions until the meter is reset. The battery gauge can be reset by unplugging the main battery connector. Also, the SQUEEGEE/VACUUM FAN FUNCTIONS will be cancelled, as if the Squeegee/Vacuum Fan button was toggled. After this occurs, the operator can press the Squeegee/Vacuum Fan button, and the squeegee will drop and the vacuum fan will run for about 30 seconds to pick up any excess water.

**The battery meter is reset each time the main battery connector is removed.** Each time the machine is turned OFF, it will store the current state of battery charge. When the machine is again turned ON, it will recall the last state of charge, and display it on the touch panel. If the main battery connector is disconnected, the controller will assume the machine has been charged. The battery meter will be reset the next time the key is turned ON.

**RECOVERY TANK FULL FLOAT SWITCH** - If the recovery tank becomes full (S4 closes), the SCRUB and SQUEEGEE/VACUUM FAN FUNCTIONS will turn OFF. If the Recovery Tank Full float switch (S4) is closed for more than 3 seconds, the Recovery Tank Full LED will turn ON and stay ON. If the scrub and/or squeegee/vacuum fan functions are ON, they will turn OFF (the vacuum fan will turn off after a slight delay). After this occurs, the operator can press the Squeegee/Vacuum Fan button, and the squeegee will drop and the vacuum fan will run for about 30 seconds to pick up any excess water. The Recovery Tank Full LED will not turn off by simply emptying the recovery tank. The Recovery Tank Full LED will remain illuminated until at least one of the following action occur:

1. The Recovery Tank float switch (S4) opens and the Scrub button is pushed.
2. The Recovery Tank float switch (S4) opens and the Squeegee/Vacuum Fan button is pushed.
3. The Recovery Tank float switch (S4) opens and the key switch is cycled OFF, then restarted.

**BRUSH MOTOR ERROR** - If a scrub brush circuit breaker (CB8 or CB9) opens while scrubbing, the machine will cancel the SCRUB FUNCTIONS as if the Scrub button was toggled. Also, the SQUEEGEE/VACUUM FAN FUNCTIONS will be cancelled as if the Squeegee/Vacuum Fan button was toggled. If the operator presses the Squeegee/Vacuum Fan button, squeegee and vacuum fan functions will resume. ALL FOUR BRUSH PRESSURE LED'S will begin to blink, alerting the operator to the open breaker condition.



# T15 Operating & Configuration Modes

(Page 4 of 12)

Mode	Entry Sequence / Indicator	Function / Notes
<b>SELF TEST MODE</b>	<ol style="list-style-type: none"> <li>1) Press and hold the "Squeegee/Vacuum Fan" button.</li> <li>2) Turn key switch to the start position, then release key.</li> <li>3) Hold "Squeegee/Vacuum Fan" button for 5 seconds.</li> <li>4) Release the "Squeegee/Vacuum Fan" button. Battery LED # 4 will flash.</li> </ol>	<p>Tests the operation of the Machine Control Board and exercises all of its outputs. When this mode is engaged, various motors and accessories will be engaged at full power as part of the test. Extreme care must be taken to be sure that technicians and bystanders are not injured as a result of this test.</p>

## SELF TEST MODE

The purpose of the Self Test Mode is to test the operation of the Machine Control Board and to exercise all of its outputs. **When this mode is engaged, various motors and accessories will be engaged at full power as part of the test. Extreme care must be taken to be sure that technicians and bystanders are not injured as a result of this test.**

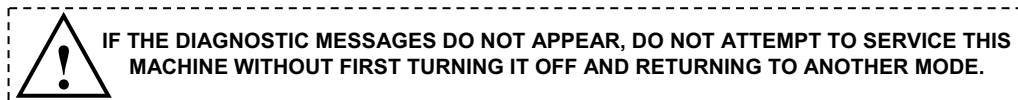

The Self Test Mode tests each of the following controller board functions:

1. Squeegee actuator.
2. Scrub head actuator.
3. Scrub brush motor current.
4. Hour meter output.
5. Conventional water valve output.
6. ES pump or FaST relay output.
7. Vacuum fan contactor output.
8. Scrub brush contactor output.
9. ES Air flush output.

When the operator releases the squeegee button, the Machine Control Board will run the squeegee and the brush head actuators to the up positions. It will then run the following procedure:

1. Turn on the vacuum fan and lower the squeegee.
2. Wait for the actuator to stall, flag error for always stalled, early stall, or never stalled.
3. Raise squeegee.
4. Drop scrub head about 2 inches.
5. Raise scrub head.
6. Wait for the actuator to stall, flag error for always stalled, early stall, or never stalled
7. Check brush motor current with brush motors off. Flag error for current sensed.
8. Turn on the brush motors.
9. Flag error for zero current, low current, or high current.
10. Turn off the brush motors.
11. Cycle and test the ES pump or FaST relay output.
12. Cycle and test the ES air flush output.
13. Cycle and test the vacuum fan output.
14. Cycle and test the scrub brush motor output.
15. Cycle and test the hour meter output.
16. Cycle and test the conventional water valve output.
17. Blink the squeegee light (green) for system passed, blink the overflow light (red) for system failed.

# T15 Operating & Configuration Modes

(Page 5 of 12)

## SELF TEST MODE (continued)

**SELF TEST ERROR CODES** - To interrogate the machine to determine the nature of a diagnostic failure, the technician must use the buttons on the instrument panel. A group of error codes are associated to each button on the instrument panel. If the technician presses the button assigned to a group that has sensed an error, the controller will display the error code using the brush pressure LED's. If the technician presses a button assigned to a group that has not sensed an error, the controller will display no error code on the brush pressure LED's. The error code assignments are as follows:

### SQUEEGEE BUTTON PRESSED (ACTUATOR GROUP)

BRUSH PRESSURE LED 1	BRUSH PRESSURE LED 2	BRUSH PRESSURE LED 3	BRUSH PRESSURE LED 4	ERROR
ON	-	-	-	No squeegee actuator zero current
-	ON	-	-	Early squeegee stall
ON	ON	-	-	No squeegee stall
-	-	ON	-	No brush actuator zero current
-	-	-	ON	Early brush stall
-	-	ON	ON	No brush stall

### SCRUB BUTTON PRESSED (BRUSH MOTOR GROUP)

BRUSH PRESSURE LED 1	BRUSH PRESSURE LED 2	BRUSH PRESSURE LED 3	BRUSH PRESSURE LED 4	ERROR
ON	-	-	-	No brush motor zero current
ON	ON	-	-	Zero brush motor current
ON	ON	ON	-	Low brush motor current
ON	ON	ON	ON	High brush motor current

### ES/FaST BUTTON PRESSED (ACCESSORY OUTPUT GROUP)

ES/FaST LED	SQUEEGEE LED	BRUSH PRESSURE LED 1	BRUSH PRESSURE LED 2	BRUSH PRESSURE LED 3	BRUSH PRESSURE LED 4	ERROR
ON	-	-	-	-	-	Air Flush valve output
-	ON	-	-	-	-	Hour meter output
-	-	ON	-	-	-	Water valve output
-	-	-	ON	-	-	ES pump output
-	-	-	-	ON	-	Fan contactor output
-	-	-	-	-	ON	Brush contactor output



# T15 Operating & Configuration Modes

(Page 6 of 12)

## SELF TEST MODE TROUBLESHOOTING

### IF ERROR READS = "BRUSH CONTACTOR OUTPUT"

(ES BUTTON HELD, DOWN PRESSURE LED #4 IS LIT)

- DISCONNECT 12A/GRN AT M3 AND RERUN SELF TEST
- NO ERROR NOW = REPLACE M3
- SAME ERROR STILL: DISCONNECT CONTROL BOARD, VERIFY 12A/GRN IS NOT SHORTED TO GROUND-- THEN REPLACE THE CONTROL BOARD

### IF ERROR READS = "NO BRUSH ACTUATOR ZERO CURRENT"

(SQUEEGEE BUTTON HELD, DOWN PRESSURE LED #3 IS LIT)

- REPLACE THE CONTROL BOARD

### IF ERROR READS = "EARLY BRUSH STALL"

(SQUEEGEE BUTTON HELD, DOWN PRESSURE LED #4 IS LIT)

- DISCONNECT BRUSH HEAD ACTUATOR AND RE-RUN SELF TEST
- SAVE ERROR: 18/BRN AND 19/GRN ARE SHORTED OR CONTROL BOARD IS BAD
- NOW GET "NO BRUSH STALL" ERROR: REPLACE BRUSH HEAD ACTUATOR

### IF ERROR READS = "NO BRUSH STALL"

(SQUEEGEE BUTTON HELD, DOWN PRESSURE LED #3 AND #4 ARE LIT)

- 18/BRN, 19/GRN, OR THE BRUSH HEAD ACTUATOR ARE OPEN

### IF ERROR READS = "NO BRUSH MOTOR ZERO CURRENT"

(SCRUB BUTTON HELD, DOWN PRESSURE LED #1 IS LIT)

- IF THE BRUSHES ARE ALWAYS ON WHEN THE KEY SWITCH IS ON: REPLACE M3 CONTACTOR
- IF THE BRUSHES TURN ON AND OFF DURING SELF TEST: THE CIRCUIT BOARD SHOULD BE REPLACED

### IF ERROR READS = "ZERO BRUSH MOTOR CURRENT"

(SQUEEGEE BUTTON HELD, DOWN PRESSURE LED #2 IS LIT AND BRUSHES TURNED ON DURING SELF TEST)

- THE SHUNT SIGNAL IS NOT GETTING TO THE CONTROL BOARD
- CHECK WIRES 88/BLK, 87/CLR, AND THE SHUNT HARNESS CONNECTIONS
- VERIFY THAT THE SHUNT IS HOOKED UP AS PER SCHEMATIC
- REPLACE THE SHUNT AS NECESSARY

E

# T15 Operating & Configuration Modes

(Page 7 of 12)

## SELF TEST MODE TROUBLESHOOTING (cont'd)

**IF ERROR READS = "ZERO BRUSH CURRENT"**  
**(AND BRUSH MOTORS DID NOT TURN ON DURING SELF TEST)**

- RUN MANUAL MODE (SEE PAGE 4-62)
- TURN ON SCRUB SYSTEM
- 12A/GRN IS BEING SWITCHED TO GROUND AT P3-11, TURNING ON M3, AND SUPPLYING VOLTAGE TO BRUSH MOTORS
- M3 IS BAD OR 12A/GRN, 10E/YEL, 1B/RED, 4/YEL, 4A/YEL, CB-8, CB-9, 64/PUR, 62/BLU, 13AH/BLK, 13AJ/BLK, OR THE SHUNT HARNESS IS OPEN
- CHECK FOR VOLTAGE FROM 62/BLU TO 66/GRN AND FROM 64/PUR TO 66/GRN AT THE BRUSH MOTORS-- IF VOLTAGE = B+ REPLACE BRUSH MOTORS
- IF VOLTAGE = 0 VOLTAGE-- GO TO STEP 6

**IF ERROR READS = "LOW BRUSH CURRENT"**  
**(SCRUB BUTTON HELD, DOWN PRESSURE LED #3 IS LIT)**

- GO INTO MANUAL MODE, TURN ON SCRUB BRUSHES-- VERIFY BOTH BRUSHES ARE OPERATING
- IF ONLY ONE MOTOR IS OPERATING: REPLACE OPEN WIRE OR MOTOR
- NOTE: CHECK FOR BROKEN BELTS ON THE CYLINDRICAL HEAD
- IF BOTH BRUSHES ARE TURNING-- IGNORE THIS ERROR
- SYSTEM IS TESTING GOOD

**IF ERROR READS = "HIGH BRUSH CURRENT"**  
**(SCRUB BUTTON HELD, DOWN PRESSURE LED #4 IS LIT)**

- GO INTO MANUAL MODE, TURN ON SCRUB BRUSHES
- MEASURE BRUSH CURRENT WITH AMP PROBE
- REPLACE MOTORS WITH EXCESSIVE AMP DRAW

**- IF NONE OF THESE ERRORS ARE FOUND ON THE MACHINE: THE SCRUB SYSTEM IS PASSING SELF-DIAGNOSTICS**

- DETERMINE WHAT OTHER ERROR WAS CAUSING THE SELF TEST FAILURE-- TROUBLESHOOT THAT SECTION



# T15 Operating & Configuration Modes

(Page 8 of 12)

Mode	Entry Sequence / Indicator	Function / Notes
<b>MANUAL MODE</b>	1) Press and hold the “ES” or “FaST” button. 2) Turn key switch to the start position, then release key. 3) Hold “ES” or “FaST” button for 5 seconds. 4) Release the “ES” or “FaST” button. Battery LED # 3 will flash.	Allows the technician to exercise individual functions on the machine. This mode disregards the effects of various interlocks. <b>DO NOT</b> scrub with the machine in this mode.

## MANUAL MODE

The purpose of the manual mode is to allow the technician to exercise individual functions on the machine. **This mode disregards the effects of various interlocks. Do not scrub with the machine in this mode.**

**FOR SAFETY: When Servicing Machine, Avoid Moving Parts. Do Not Wear Loose Jackets, Shirts, Or Sleeves.**

After entering the Manual Mode, the control buttons assume the following functions:

**SCRUB BUTTON** - Pressing the Scrub button will turn on and lower the main scrub head. Holding the Scrub button while scrub is active will cause the down pressure to scroll. **The head will continue down as long as the technician holds the scrub button. Care must be exercised by the technician not to hold the button too long. The actuator can stall when fully extended. Damage to the controller board and the actuator can result from continuing to provide power to a stalled actuator.** The head will stay down with the brushes running regardless of the state of the propel pedal reverse switch. The head will automatically rise when the user turns off the brushes.

**SQUEEGEE BUTTON** - Pressing the Squeegee button will turn on the vacuum fan and lower the squeegee. **WARNING: Reverse is ignored in this mode.** Squeegee will not automatically raise when in reverse.

**ES or FaST BUTTON** - Pressing the ES/FaST button will toggle the ES pump or FaST system ON or OFF. In the ON position, the ES pump or FaST system will run regardless of the state of the floats. Care should be taken not to run the ES or FaST pump(s) dry for more than a few seconds. The ES Air flush valve will cycle ON and OFF every 5 seconds.

**INTERLOCKS** - The following table shows inputs and outputs that are enabled by the various states of the inputs and interlocks during the Normal Scrub Mode. If certain functions do not work during Normal Scrub Mode, verify that the particular component functions during Manual Mode to determine if an input or interlock problem exists.



# T15 Operating & Configuration Modes

(Page 10 of 12)

Mode	Entry Sequence / Indicator	Function / Notes
<b>INPUT DISPLAY MODE</b>	<ol style="list-style-type: none"> <li>1) Press and hold the “Scrub” button.</li> <li>2) Turn key switch to the start position, then release key.</li> <li>3) Hold “Scrub” button for 5 seconds.</li> <li>4) Release the “Scrub” button. Battery LED # 2 will flash.</li> </ol>	Allows the technician to observe the effectiveness of various inputs and sensors on the machine controller board. When in this mode, the technician can scrub with the machine as normal and observe the operation of the various inputs.

## INPUT DISPLAY MODE

The purpose of the Input Display Mode is to observe the effectiveness of various inputs and sensors on the Machine Control Board. When in Input Display Mode, the machine will scrub normally but the LED's on the instrument panel no longer correspond to the normal control status. Each of the control panel LED's are associated with one board input. When an input is activated, the corresponding LED will become illuminated. For instance, in the normal mode, if the Squeegee/Vacuum Fan LED is on, this means that the squeegee and vacuum fan are active. In the Input Display Mode, this LED indicates that the solution tank is full. The buttons however, retain their normal functions. Pressing the squeegee button will turn on the squeegee and vacuum fan, even though the LED may not turn on. The Machine Control Board will temporarily display scrub pressure when the scrub button is pressed and held. If the scrub button is held long enough, the machine will scroll slowly through the various down pressures. Refer to the chart below for LED assignments while in Input Display Mode.

LED	status	description
Battery 1	Blinking	Battery voltage below 31.5V – charge batteries immediately
Battery 2	ON	Reverse propel active
Battery 3	ON	Forward propel active
Battery 4	ON	Power sensed on outputs of both brush motor circuit breakers
Squeegee/Vacuum Fan	ON	Solution tank is FULL
Recovery Tank Full	ON	Recovery tank is FULL
ES/FaST	ON	Recovery tank is half FULL or higher
Brush Pressure 1	ON	Brush current below minimum level for selected pressure level
Brush Pressure 2	Blinking	Machine controller is in Input Display Mode
Brush Pressure 3	ON	Scrubbing system ON
Brush Pressure 4	ON	Brush current above maximum level for selected pressure level

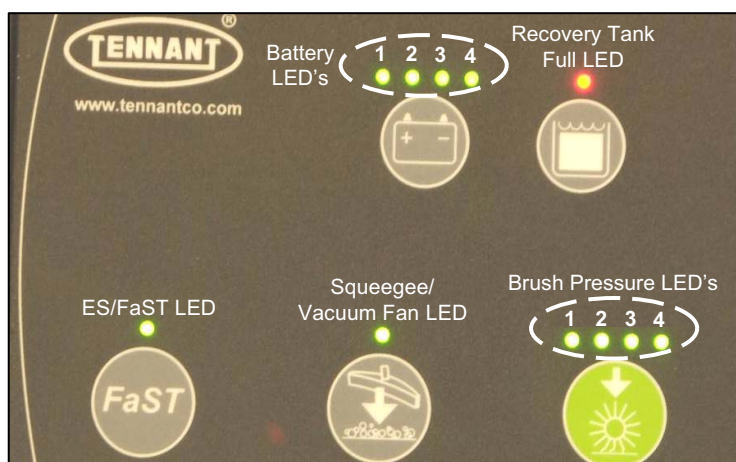



# T15 Operating & Configuration Modes

(Page 11 of 12)

Mode	Entry Sequence / Indicator	Function / Notes
<b>RESTRICTED DOWN PRESSURE MODE</b>	<ol style="list-style-type: none"> <li>1) Press and hold both the “Squeegee/Vacuum Fan” and “Scrub” buttons.</li> <li>2) Turn key switch to the start position, then release key.</li> <li>3) Hold “Squeegee/Vacuum Fan” and “Scrub” buttons until three <b>OR</b> four brush pressure LED’s start flashing.</li> <li>4) Release the “Squeegee/Vacuum Fan” and “Scrub” buttons and turn key switch OFF. The mode has now been toggled.</li> </ol>	<p>Toggles the machine between normal and a restricted down pressure setting. The normal mode allows all four down pressure LED settings. The restricted mode allows only three LED settings. Each time the Restricted Down Pressure Mode is entered, the machine will toggle between normal and restricted down pressure modes.</p>

Allows only 3 brush pressure settings

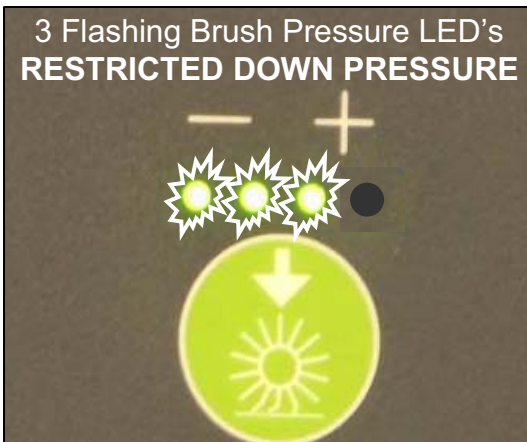

Allows all 4 brush pressure settings

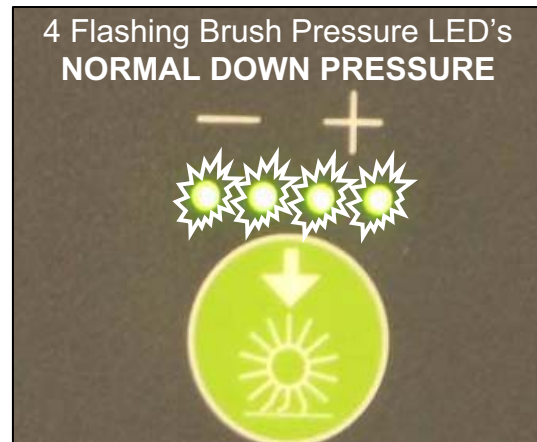

# T15 Operating & Configuration Modes

(Page 12 of 12)

Mode	Entry Sequence / Indicator	Function / Notes
<b>SOFTWARE REVISION DATE DISPLAY MODE</b>	<ol style="list-style-type: none"> <li>1) Press and hold both the “Squeegee/Vacuum Fan” and “ES/FaST” buttons.</li> <li>2) Turn key switch to the start position, then release key.</li> <li>3) Hold “Squeegee/Vacuum Fan” and “ES/FaST” buttons until the ES/FaST LED begins to flash.</li> <li>4) Release the “Squeegee/ Vacuum Fan” and “ES/FaST” buttons. The software revision date will be flashed on the touch panel.</li> <li>5) The flashing sequence will continue until the key switch is turned OFF.</li> </ol>	<p>Displays the machine's software revision date. Each sequence of flashes is separated by a pause, then repeated over and over until the key switch is turned OFF.</p> <p>The <b>MONTH</b> is displayed by the number of flashes of the “ES” or “FaST” LED.</p> <p>The <b>DAY</b> is displayed by the number of flashes of the “Squeegee/Vacuum Fan” LED.</p> <p>The <b>YEAR</b> is displayed by the number of flashes of the “Recovery Tank Full” LED.</p>

E

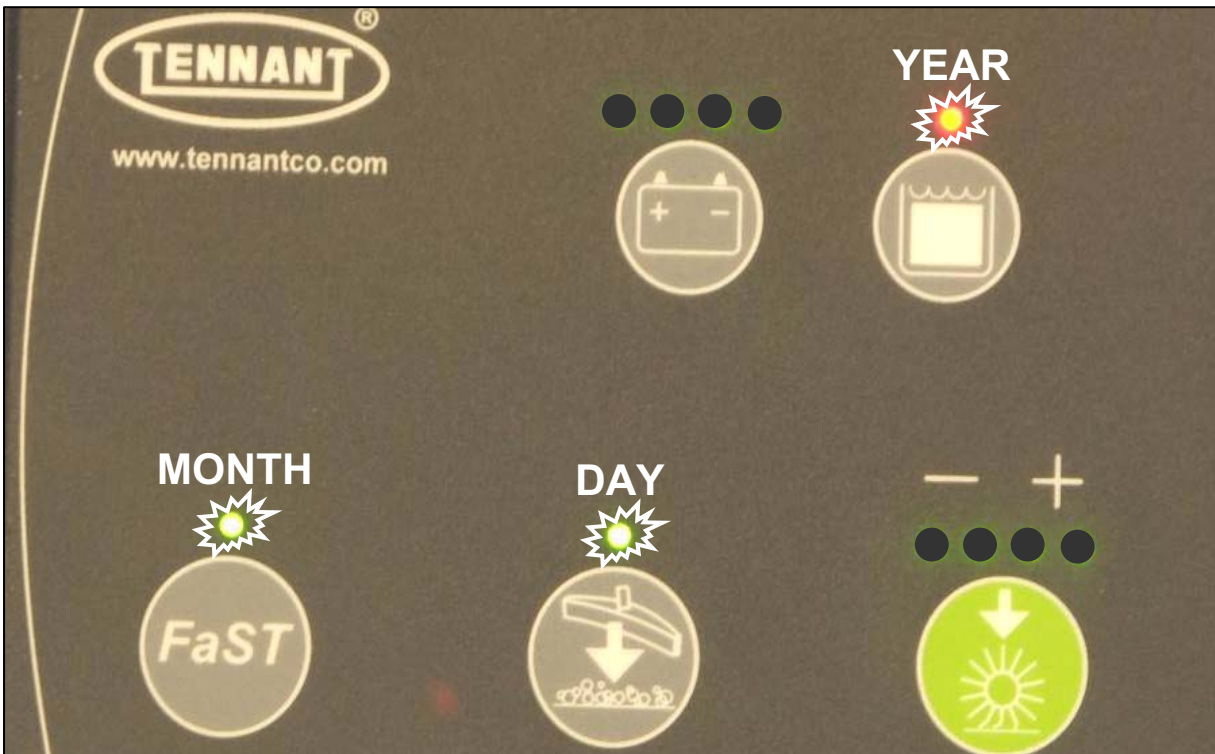



# We Need Your Help...

As part of Tennant's Zero Defects Program, we want to know about errors you have found or suggestions you may have regarding our machine manuals. If you find an error or have a suggestion, please complete this postage-paid form and mail it to us. Thank you for helping us make zero defects a way of life at Tennant.

Manual No. \_\_\_\_\_ Rev. No. \_\_\_\_\_ Publish Date \_\_\_\_\_ Page \_\_\_\_\_  
Machine \_\_\_\_\_  Report Error  Suggestion

---

---

---

---

---

---

---

---

---

---

---

---

---

---

---

---

---

Name \_\_\_\_\_ Date \_\_\_\_\_  
Customer Number \_\_\_\_\_  
Company \_\_\_\_\_  
Address \_\_\_\_\_  
City/State/Zip Code \_\_\_\_\_



**TENNANT COMPANY**  
 Technical Publications #15  
 701 North Liliac Drive  
 P.O. Box 1452  
 Minneapolis, MN 55440-9947

POSTAGE WILL BE PAID BY ADDRESSEE

**BUSINESS REPLY MAIL**  
 FIRST CLASS MAIL PERMIT NO. 94 MINNEAPOLIS, MN

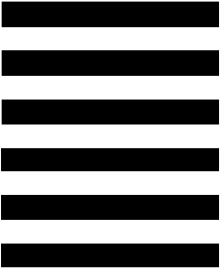

NO POSTAGE  
 NECESSARY  
 IF MAILED  
 IN THE  
 UNITED STATES



Fold along dotted lines

Tape here





# We Need Your Help...

As part of Tennant's Zero Defects Program, we want to know about errors you have found or suggestions you may have regarding our machine manuals. If you find an error or have a suggestion, please complete this postage-paid form and mail it to us. Thank you for helping us make zero defects a way of life at Tennant.

Manual No. \_\_\_\_\_ Rev. No. \_\_\_\_\_ Publish Date \_\_\_\_\_ Page \_\_\_\_\_  
 Machine \_\_\_\_\_  Report Error  Suggestion

---

---

---

---

---

---

---

---

---

---

---

---

---

---

---

---

---

---

Name \_\_\_\_\_ Date \_\_\_\_\_  
 Customer Number \_\_\_\_\_  
 Company \_\_\_\_\_  
 Address \_\_\_\_\_  
 City/State/Zip Code \_\_\_\_\_



**TENNANT COMPANY**  
 Technical Publications #15  
 701 North Lilac Drive  
 P.O. Box 1452  
 Minneapolis, MN 55440-9947

POSTAGE WILL BE PAID BY ADDRESSEE

**BUSINESS REPLY MAIL**  
 FIRST CLASS MAIL PERMIT NO. 94 MINNEAPOLIS, MN

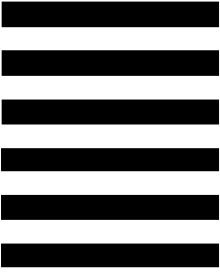

NO POSTAGE  
 NECESSARY  
 IF MAILED  
 IN THE  
 UNITED STATES

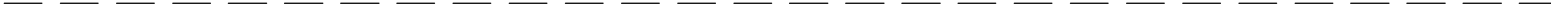

Fold along dotted lines

Tape here

