

SWLSHER

Z-MAX

ZT2460
24 HP – 60" CUT



CELEBRATING 60 YEARS OF INNOVATION

1945 - 2005

1602 CORPORATE DRIVE, P.O. BOX 67, WARRENSBURG, MISSOURI 64093
PHONE 660-747-8183 FAX 660-747-8650

Manufacturing quality lawn care equipment since 1945

Made In The

USA

1

OWNER'S MANUAL
STARTING SERIAL # L505-040001

LIMITED WARRANTY

The manufacturer's warranty to the original consumer purchaser is: This product is free from defects in materials and workmanship for a period of two (2) years from the date of purchase by the original consumer purchaser. We will repair or replace, at our discretion, parts found to be defective due to materials or workmanship. This warranty is subject to the following limitations and exclusions:

- 1) Engine Warranty All engines utilized on our products have a separate warranty extended to them by the individual engine manufacturer. Any engine service difficulty is the responsibility of the engine manufacturer and in no way is Swisher Mower Co., Inc. or its agents responsible for the engine warranty. The Briggs & Stratton Engine Service Hot-Line is 1-800-233-3723. The Tecumseh Engine Service Hot-Line is 1-800-558-5402.

- 2) Commercial Use **This product is not intended for commercial use and carries no commercial warranty.**

- 3) Limitation This warranty applies only to products which have been properly assembled, adjusted, and operated in accordance with the instructions contained within this manual. This warranty does not apply to any product of Swisher Mower Co., Inc., that has been subject to alteration, misuse, abuse, improper assembly or installation, shipping damage, or to normal wear of the product.

- 4) Exclusions Excluded from this warranty are normal wear, normal adjustments, and normal maintenance.

In the event you have a claim under this warranty, you must return the product to an authorized service dealer. All transportation charges, damage, or loss incurred during transportation of parts submitted for replacement or repair under this warranty shall be borne by the purchaser. Should you have any questions concerning this warranty, please contact us toll-free at 1-800-222-8183. The model number, serial number, date of purchase, and the name of the authorized Swisher dealer from whom you purchased the mower will be needed before any warranty claim can be processed.

THIS WARRANTY DOES NOT APPLY TO ANY INCIDENTAL OR CONSEQUENTIAL DAMAGES AND ANY IMPLIED WARRANTIES ARE LIMITED TO THE SAME TIME PERIODS STATED HEREIN FOR ALL EXPRESSED WARRANTIES. Some states do not allow the limitation of consequential damages or limitations on how long an implied warranty may last, so the above limitations or exclusions may not apply to you. This warranty gives you specific legal rights and you may have other rights, which vary from state-to-state. This is a limited warranty as defined by the Magnuson-Moss Act of 1975.

CONTENTS

LIMITED WARRANTY.....	2	OPERATION.....	16
INTRODUCTION.....	4	Features.....	16
General.....	4	Starting.....	19
Before Operating.....	4	Grass Height of Cut.....	19
Uncrating & Assembly.....	5	Controls.....	20
SYMBOLS & DECALS.....	6	SERVICE & ADJUSTMENTS..	21
SAFETY INSTRUCTIONS....	8	Adjusting Deck Height.....	21
General use and safety rules...	8	Deck Level.....	21
Slope Operation.....	10	Deck Belt Replacement....	22
Children Safety.....	10	Hydro Belt Replacement....	23
SPECIFICATIONS.....	11	Seat Adjustment.....	24
CUSTOMER		Parking Brakes.....	25
RESPONSIBILITY.....	12	WIRING SCHEMATIC.....	26
Operator Presence.....	12	PARTS BREAKDOWN.....	27
Tires.....	12	TROUBLESHOOTING.....	34
Blade Maintenance.....	13	MOWER IDENTIFICATION....	37
Battery.....	13	REPLACEMENT PARTS.....	38
V-belts.....	14	MAINTENCE LOG.....	39
Engine.....	14	SWISHER HISTORY.....	40
Overall Unit Care.....	14		
Transporting Safety.....	14		
Maintenance.....	15		

INTRODUCTION

Introduction

Congratulations

Thank you for purchasing a Swisher Zero Turn mower. This machine is built for the greatest efficiency and rapid mowing of large areas. Conveniently located controls and dual commercial grade hydrostatic transmissions regulated by steering levers, contribute to the machine's performance.

This manual is a valuable document. Following the instructions for use, service, maintenance, etc. can greatly increase the life-span of your machine .

General

In this operator's manual, left and right, backward and forward are used in relation to the normal operators position.

Read Before Operating

NOTE:

If you have never used a Zero Turn mower before, refer to the Operation Controls section of this manual before attempting to operate one for the first time.

This machine is constructed only for mowing grass on lawns and other free and even ground without obstacles. This machine is not intended for commercial use. The manufacturer's directions concerning operation, maintenance, and repairs must be carefully followed.

This machine must only be operated, maintained, and repaired by persons that are familiar with the machine's special characteristics and who are well versed in safety instructions.

Accident prevention regulations, other general safety regulations, occupational safety rules, and traffic regulations must be followed without fail.

Unauthorized modifications to the design of the machine may absolve the manufacturer from liability for any resulting personal injury or property damage.

- Read engine manufacturer's operating and maintenance instructions.
- Read and observe all safety instructions on your mower and in the manual
- Check engine oil.
- Check fuel caps to sure that they are in place.
- Set control handles outward – setting parking brake
- Be sure mower blades are turned off – PTO switch pushed down.
- Know how to stop the engine – Turn key to off
- Know how to stop the unit – Return control handles to neutral

INTRODUCTION

Uncrating & Assembly

TOOLS REQUIRED:

- ✓ 2 - ½” Wrenches or ½” Socket with drive ratchet
- ✓ Tire pressure gauge
- ✓ Nail bar or claw hammer
- ✓ Wire snips

To Remove The Mower From The Crate

- Dispose of top and side panels of the crate.
- Remove loose parts and packing material
- Cut any banding or strapping that may be holding the mower to the crate.
- Disengage spark plug wire and place where it cannot make a connection.
- Raise the mower deck to its highest position..
- Disengage the parking brakes by placing the handle controls in the upright position.
- Open the transmission valves at the rear of the unit by pulling the release rods and locking them in place. **SEE INSTRUCTION DECAL AT THE REAR OF THE UNIT.**
- Carefully push the mower off the crate to a safe and level area.
- Check engine oil. All engines are filled with oil and tested at the factory. Verify oil level and add if necessary before starting engine. **SEE ENGINE OWNER’S MANUAL**
- Check the battery. If the battery is put into service after the “month & year” of the date on the battery, then it may need to be charged with a 12 volt charger for a minimum of 1 hour, but no more than 2 hours at a rate of 6 to 10 amps.
- Attach battery cables to battery. **Always attach the positive terminal first.**
- Install steering levers. Remove the bolts from the control arms on the mower. Align the holes in the lever with the holes in the control arms and attach with the bolts provided. **Make sure both bolts on both handles are tight.**
- Close the transmission valves at the rear of the unit. **SEE INSTRUCTION DECAL AT THE REAR OF THE UNIT.**
- Reconnect spark plug wire.
- Check tire pressure on all four wheels. **REFER TO UNIT SPECIFICATIONS TABLE**

SYMBOLS & DECALS

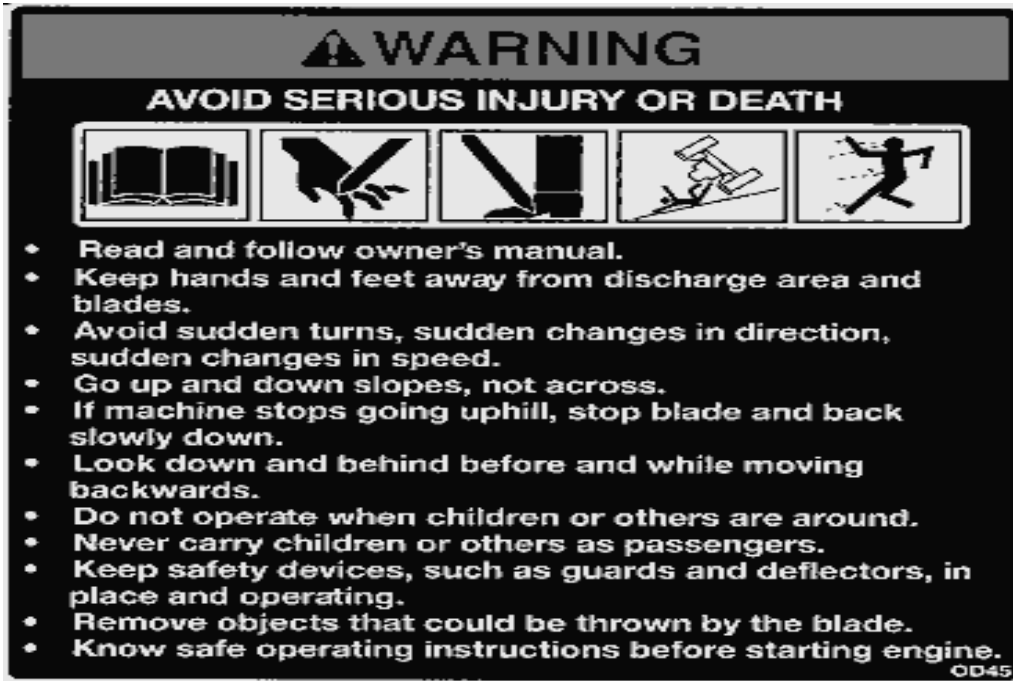

OD45- Warning Decal



Swisher Flag U.S.A.– OD39



Notice Do Not Alter Wiring Decal– OD74



Operator Must Be Seated Decal– OD73

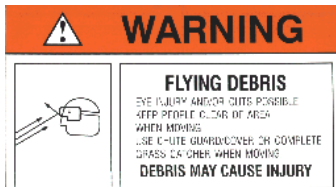

Flying Debris Decal – OD43



Triangle Danger Decal – OD55



No Step Decal – OD11

SYMBOLS & DECALS cont.

Parking Brake Decal

Left - 10270



Parking Brake Decal

Right - 10279

Key/PTO Decal - 10273

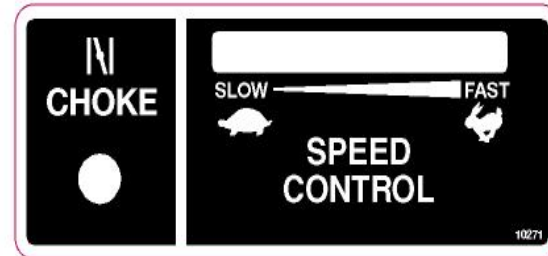
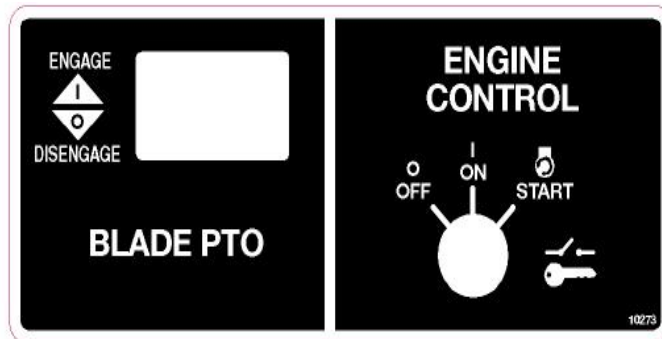

Throttle/Choke Decal - 10271



Hydro Release - 10280

⚠ DANGER	⚠ WARNING
<p>AVOID SERIOUS INJURY OR DEATH - ROTATING BLADES CUT OFF ARMS & LEGS</p> <ul style="list-style-type: none"> • Read owner's manual. • Go up and down slopes (15° maximum) not across. • Always operate only in lowest gear going downhill or uphill. • Keep safety devices (guards, shields, and switches) in place and working. • Remove objects that could be thrown by the blades. • If machine stops going uphill, stop blades and back slowly down. • Be sure blades and engine have stopped before placing hands or feet near blades. • Avoid sudden turns. • Always set parking brake before leaving seat. • Do not mow when children or others are in the mowing area. • Look down and behind before and while backing. • Never carry passengers or children even with blades off. 	<p>AVOID SERIOUS INJURY OR DEATH</p> <ul style="list-style-type: none"> • Read and follow owner's manual. • Keep hands and feet away from discharge area and blades. • Avoid sudden turns, sudden changes in direction, sudden changes in speed. • Go up and down slopes, not across. • If machine stops going uphill, stop blade and back slowly down. • Look down and behind before and while moving backwards. • Do not operate when children or others are around. • Never carry children or others as passengers. • Keep safety devices, such as guards and deflectors, in place and operating. • Remove objects that could be thrown by the blade. • Know safe operating instructions before starting engine.

Danger/Warning Decal - 10276

Decals Not Shown

- OD99128 60" Deck White Decal
- 10275 ZT2460 Decal Small
- 10281 Height Adjust Decal
- 10542 Replacement Parts Decal
- 10274 Z-Max Decal
- OD99125 Medium Swisher Decal

SAFETY INSTRUCTIONS

Safety Instructions

These instructions are for your safety. Read them carefully.



This Safety Alert Symbol indicates important messages in this manual. When you see this symbol, carefully read the message that follows and be alert to the possibility of personal injury.

General Use

- Read all instructions in this operator's manual and on the machine before starting it. Ensure that you understand them and then abide by them.
- Learn how to use the machine and its controls safely and learn how to stop quickly. Also learn to recognize the safety decals.
- Only allow the machine to be used by adults who are familiar with its use.
- Make sure nobody else is in the area of the machine when you start the engine, engage the drive, or run the machine.
- Stop the machine if someone enters the work area.
- Clear the area of objects such as stones, toys, steel wire, etc. that may become caught in the blades and thrown out.
- **Do Not Use this machine without the Discharge Chute in place.**
- Stop the engine and disconnect the spark plug before cleaning the discharge deck.
- Never take passengers. The machine is only intended for use by one person.

NOTE:

If you have never used a Zero Turn mower before, refer to the Operation Controls section of this manual before attempting to operate one for the first time.

SAFETY INSTRUCTIONS

General Use Continued

- Always look around before and during reversing maneuvers.
- Slow down before turning.
- Shut down the mower deck when not mowing.
- Be careful when rounding fixed objects, so that the blades do not hit them.
- Only operate the machine in daylight or other well-lit conditions.
- Keep the machine a safe distance from holes or other irregularities in the ground.
- Never use the machine if you are tired, if you have consumed alcohol, or if you are taking other drugs or medications that can affect your vision, judgment, or coordination.
- Beware of traffic when working near or crossing a road.
- Never leave the machine unsupervised with the engine running. Always shut down the blades, engage the parking brakes, stop the engine, and remove the ignition key before leaving the machine.
- Never allow children or other persons not trained in the use of the machine to use or service it. Local laws may regulate the age of the user.
- Make sure that you have first aid equipment close at hand when using the machine.
- Never use the machine when barefoot. Always wear protective shoes or boots.
- Always wear approved protective glasses or a full visor when assembling or driving.
- Ear Protection is recommended
- Never wear loose clothing that can get caught in moving parts.

Remember

The operator is responsible for avoiding dangers or accidents.



WARNING

When using the machine, approved personal protective equipment shall be used. Personal protective equipment cannot eliminate the risk of injury, but it will reduce the degree of injury if an accident does occur. Ask your retailer for help in choosing the right equipment.



SAFETY INSTRUCTIONS

Slope Operation

- Remove obstacles such as stones, tree branches, etc.
- Mow up and down, not side to side. Never drive the rider on terrain that slopes more than 10 degrees.
- Avoid starting or stopping on a slope. If the tires begin to slip, shut down the blades and drive slowly down the slope.
- Always drive evenly and slowly on slopes.
- Make no sudden changes in speed or direction.
- Avoid unnecessary turns on slopes, and if it proves necessary, turn slowly and gradually downward, if possible.
- Watch for holes, ruts, or bumps. On uneven terrain, the machine can tip more easily. Long grass can hide obstacles.
- Drive slowly and use small movements of the steering controls.
- Do not mow wet grass. It is slippery, and the tires can lose their grip, so that the machine slides.
- Do not try to stabilize the machine by putting a foot on the ground.

Remember

The operator is responsible for avoiding dangers or accidents.

Children

- Serious accidents may occur if you fail to be on guard for children in the area of the machine. Children are often attracted to the machine and mowing work. Never assume that children will stay put where you last saw them.
- Keep children away from the mowing area and under close supervision by another adult.
- Shut off the machine if children enter the work area.
- Never allow a child to ride with you.
- Never allow children to operate the machine.
- Be extra cautious near corners, bushes, trees, or other objects that block your view.

SPECIFICATIONS

GASOLINE CAPACITY AND TYPE	DUAL 2.0 GAL TANKS UNLEADED REGULAR
OIL TYPE (SPI-SF-SJ):	SEE ENGINE MANUAL
SPARK PLUG	SEE ENGINE MANUAL
GROUND SPEED	0 – 6 mph
TIRE SIZE	FRONT: 4.10x3.5-5 5/8 Bearing REAR: 20 X 10 X 8
TIRE PRESSURE	FRONT: 50 psi Max REAR: 22 psi Max
BATTERY	12V / Heavy Duty 275 CCA Type U1L
HYDRO Bolt Torque	27 + - 3 ft. lbs
BLADE BOLT TORQUE	35 ft. lbs
CUTTING HEIGHT	1.5” – 5”
CUTTING WIDTH	60” – 3 Mulching Blade System
PARKING BRAKE	Automatic - On Steering Handles
FRONT AXLE	Pivoting
SEAT	Deluxe 18” Back w/ Arm Rest 6” Adjustable Slide
TRANSMISSION	Commercial Grade Eaton Hydrostatic
DECK LIFT	Spring Assisted
UNIT MEASUREMENTS	LENGTH: 70” WIDTH: 60 ¼” “ Including Deck WEIGHT: 680 lbs

CUSTOMER RESPONSIBILITIES

Operator Presence System

Be sure the operator presence and interlock systems are working properly. If your mower does not function as described, repair the problem immediately.

- The engine should not start unless the parking brakes (handle controls) are engaged (rotated outward), the PTO (Blade Engagement – See OPERATION FEATURES section of this manual) switch is disengaged (pressed down), and the operator is on the seat.

- When the engine is running, any attempt by the operator to leave the seat without first setting the parking brake should shut off the engine.

- When the engine is running and the PTO switch is engaged, any attempt by the operator to leave the seat without first disengaging the PTO switch, should shut off the engine.

- When the engine is running and the control levers are rotated in, any attempt by the operator to leave the seat without rotating the control levers out, should shut off the engine.

- The PTO switch should never engage without the operator on the seat.

Tires

- Maintain proper air pressure in all tires (SEE SPECIFICATIONS section)

- Keep tires free of gasoline, oil, or insect control chemicals which can harm rubber.

- Avoid stumps, stones, deep ruts, sharp objects and other hazards that may cause tire damage.

CUSTOMER RESPONSIBILITIES

Blade Maintenance



CAUTION

Stop engine and remove ignition key for safety. Disconnect spark plug wire. Wear heavy, thick gloves when holding onto blade. Avoid the sharp edge of the blade.

For best results, mower blades must be kept sharp. Replace bent or damage blades.

- Safely raise front of mower. SEE WARNING
- Hold or block blade from turning.
- Loosen blade nut and remove blade.
- Replace blade, (SEE SPECIFICATIONS).



WARNING

When it is necessary to raise the mower for any repair or service, use jackstands to provide adequate support. DO NOT rely on hydraulic or mechanical jacks

Battery



WARNING

The battery contains sulfuric acid and electrolytes which are poisonous and corrosive.

- The battery is a maintenance-free battery and the fluid level cannot be checked.
- Charge battery if needed.

To clean battery and terminals

- Remove terminal guard.
- Disconnect the BLACK battery cable first, then the RED battery cable and remove the battery.
- Rinse the battery with plain water and dry.
- Clean terminals and battery cable ends with wire brush until shiny.
- Coat terminals with grease or petroleum jelly
- Reinstall battery
- Reconnect the battery cables

CUSTOMER RESPONSIBILITIES

V-Belts

Check V-belts for deterioration and wear after 100 hours of operation and replace if necessary. Replace belts if they begin to slip from wear. SEE SPECIFICATION for belt part numbers and SERVICE section of this manual for instructions on how to replace the belt.

Engine

REFER TO YOUR ENGINE OWNERS MANUAL

Overall Unit Care

- Reduce the risk of fire by removing grass, leaves, and other debris that may have accumulated on the machine. Allow the machine time to cool before cleaning or putting it in storage.

- Wash mower periodically. Clean above and below deck.

- Keep all electrical connections clean and tight.

Driving and Transport on Public Roads

- Check applicable road traffic regulations before driving and transporting on public roads.

- If the machine is transported, you should always use approved fastening equipment and ensure that the machine is well anchored.

- The cutting deck should also be lowered to the lowest position and the steering levers should be in the outward position, so that the parking brake is engaged.

CUSTOMER RESPONSIBILITIES

MAINTENANCE SCHEDULE

	Before Each Use	8 Hours	25 Hours	50 Hours	100 Hours	Season	Before Storage
Check Brake Operation	X	X					
Check Tire Pressure	X	X					
Check Operator Presence	X						
Parking Brake	x						
Check for Loose Fasteners	X				X		X
Sharpen/Replace Mower Blades			X3				
Check Battery			X				X
Clean Battery & Terminals			X				X
Check Belts					X		
Check Engine Oil	X	X					
Change Engine Oil w/ filter				X1,2			
Change Engine Oil w/o filter			X1,2				
Replace Oil Filter					X1,2		
Clean Air Filter			X2				
Inspect Muffler				X			
Clean Engine Cooling Fins					X2		
Replace Spark Plug					X	X	
Replace Fuel Filter						X	

1 – Change more often when operating under a heavy load or in high ambient temperatures

2 – Service more often when operating in dirty or dusty conditions

3 – Replace blades more often when mowing in sandy soil

OPERATION

FEATURES



1. Throttle Control – Used to control Engine Speed
2. Hour Meter – Indicates hours of operation
3. Choke Control – Used when starting a cold engine
4. PTO Switch – Used to engage or disengage the deck blades
5. Ignition Switch – Used to start or stop the engine
6. Deck Lift Handle – Used to raise and lower the cutting deck

7. Control Levers / Parking Brake – Sets the speed of the mower in both the forward and reverse directions and also turns the mower / Engages and disengages the Automatic Parking Brake system
8. Hydro Bypass – Engages transmissions for normal operation and disengages transmissions for pushing or pulling the unit
9. Fuel Tanks – Dual 2.0 gal fuel tanks
10. Seat Slide
11. Battery
12. Pivoting Front Axle
13. Discharge Chute

OPERATION

FEATURES



1. Throttle Control – Used to control Engine Speed
2. Hour Meter – Indicates hours of operation
3. Choke Control – Used when starting a cold engine
4. PTO Switch – Used to engage or disengage the deck blades
5. Ignition Switch – Used to start or stop the engine
6. Deck Lift Handle – Used to raise and lower the cutting deck

7. Control Levers / Parking Brake – Sets the speed of the mower in both the forward and reverse directions and also turns the mower / Engages and disengages the Automatic Parking Brake system
8. Hydro Bypass – Engages transmissions for normal operation and disengages transmissions for pushing or pulling the unit
9. Fuel Tanks – Dual 2.0 gal fuel tanks
10. Seat Slide
11. Battery
12. Pivoting Front Axle
13. Discharge Chute

OPERATION

FEATURES

Left Control Panel

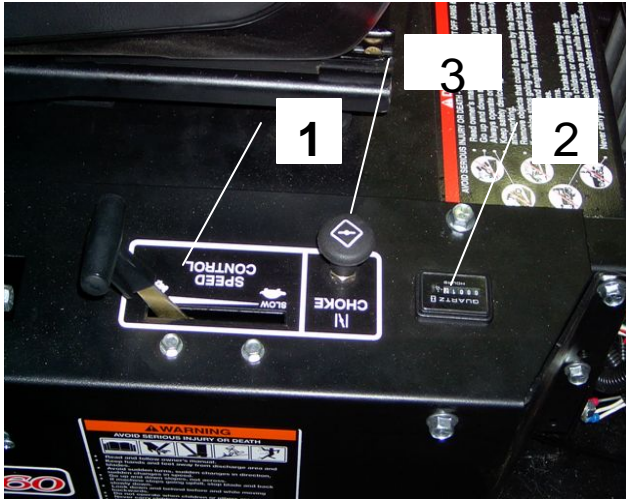

Right Control Panel

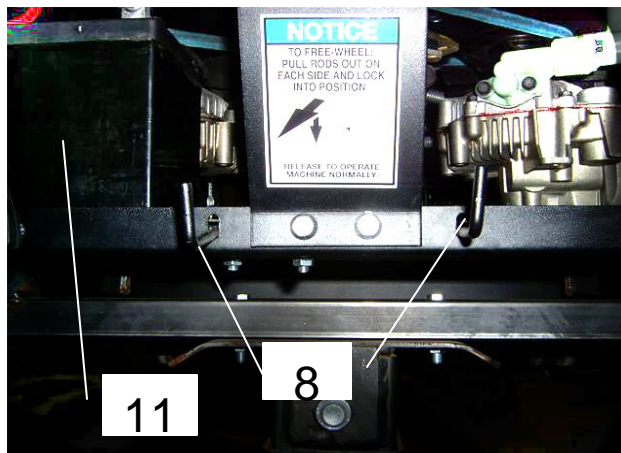
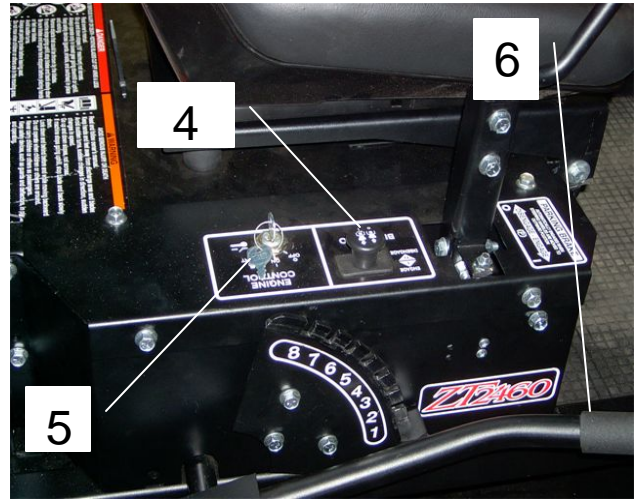

Rear of Unit

- | | |
|---|--|
| <ol style="list-style-type: none"> 1. Throttle Control – Used to control Engine Speed 2. Hour Meter – Indicates hours of operation 3. Choke Control – Used when starting a cold engine 4. PTO Switch – Used to engage or disengage the deck blades 5. Ignition Switch – Used to start or stop the engine 6. Deck Lift Handle – Used to raise and lower the cutting deck | <ol style="list-style-type: none"> 7. Control Levers / Parking Brake – Sets the speed of the mower in both the forward and reverse directions and also turns the mower / Engages and disengages the Automatic Parking Brake system 8. Hydro Bypass – Engages transmissions for normal operation and disengages transmissions for pushing or pulling the unit 9. Fuel Tanks – Dual 2.0 gal fuel tanks 10. Seat Slide 11. Battery 12. Pivoting Front Axle 13. Discharge Chute |
|---|--|

OPERATION

Starting

- Operator must be sitting in the seat. Control handles must be in the neutral (outward) position (which sets the parking brakes). PTO must be in the disengage position (pushed down).
- Set choke (if needed), turn key and release as soon as engine starts. Adjust throttle to half and shut choke off.
- Close motion control levers (move inward), releasing the Parking Brakes
- Be sure all people are clear of the area. Engage blades and set RPM to maximum.

NOTE:

If you have never used a Zero Turn mower before, refer to the Operation Controls section of this manual before attempting to operate one for the first time.

Grass Height & Cutting Suggestions

- Do not attempt to cut wet grass
- The average lawn should be cut to 2 ½” during the cool season and to over 3” during the hot months. For healthier and better looking lawns, mow often and after moderate growth.
- As a rule , never cut more than 1/3 of the total grass blade length. Correct mowing height can reduce weeds and lawn disease.
- For best performance, grass over 6 inches in height should be mowed twice. The first cut should be set relatively high and the second set to the desired height.

OPERATION

Controls

➤ Be familiar with all controls, their functions and how to operate them before starting the machine.

➤ Motion control levers on each side of the console control the direction of movement. SEE FIGURE BELOW

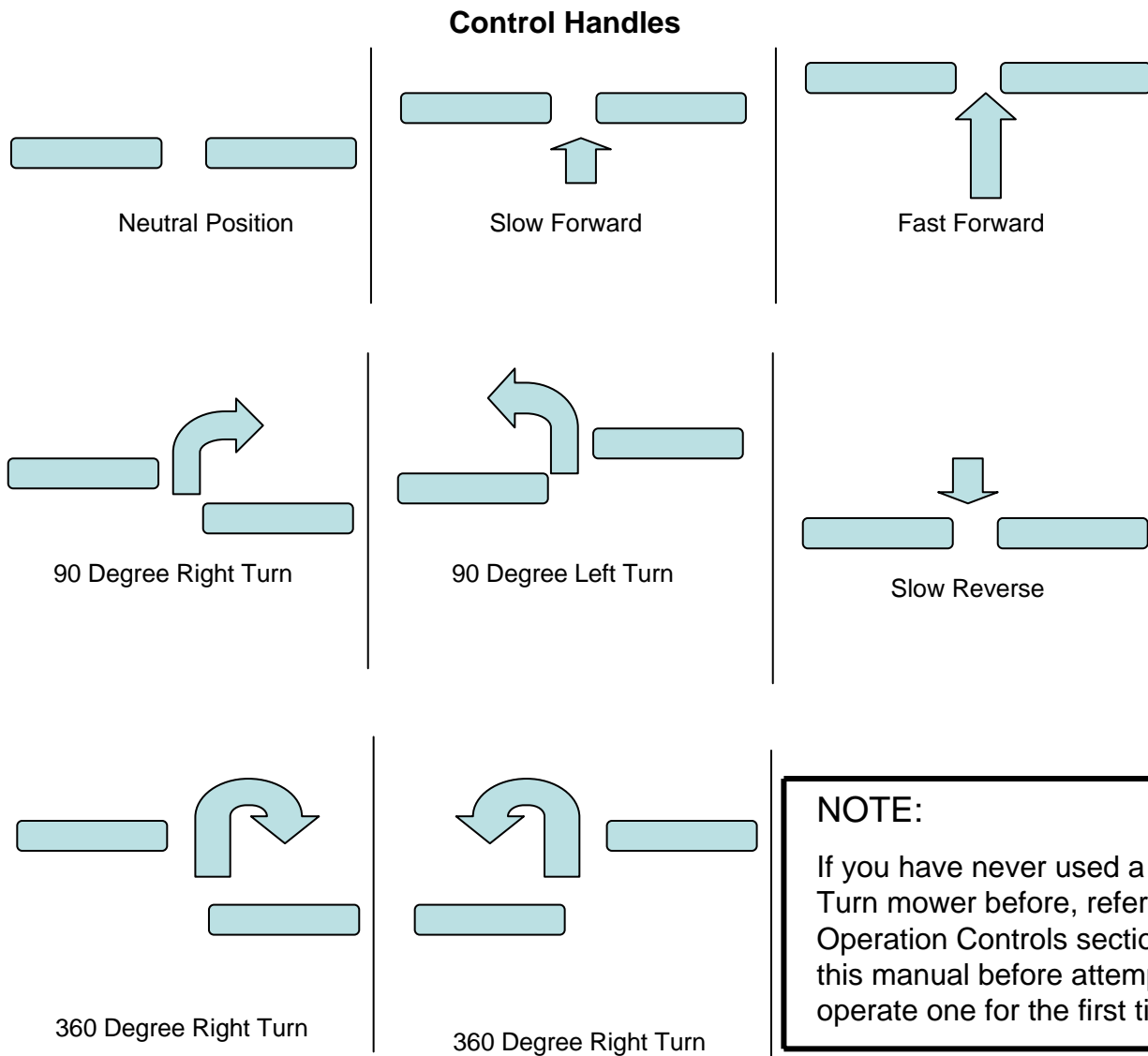

Note: The pressure required to operate the mower is very slight

SERVICE & ADJUSTMENTS

Adjusting The Cutting Height

- Push out on the Deck Lift Handle and raise or lower the deck to the desired position.

- Position 1 is the lowest setting and Position 8 is the highest position

- The cutting range is from approximately 1 ½" to approximately 5"

Deck Leveling

TOOLS REQUIRED:

- ✓ 2 - ½" Wrenches or ½" Socket with drive ratchet

- Lower the cutting deck down to the lowest position (position 1)
- Loosen the nuts on the top side of the deck hanger brackets (3 places) where the lift cables attach to.
- With all three loose on top of the brackets the deck should now set on the ground resting on the roller wheels.
- Tighten the nuts on the top of the lift brackets making sure that all three lift cables are pulled tight.
- Lift deck using the deck lift handle to the desired position

SERVICE & ADJUSTMENTS

Deck Belt Routing & Replacement

Removal

- ✓ Disconnect spark plug wire
- ✓ Apply parking brake
- ✓ Lower the deck to its lowest position
- ✓ Remove the belt covers
- ✓ Disconnect tension idler
- ✓ Roll the belt over the top of the deck pulleys
- ✓ Remove belt

Replacement

- ✓ Install new belt by placing it around the deck pulleys. Refer to routing diagram below.
- ✓ The belt will be loose at this time
- ✓ Tightly secure the belt tension back to its original position
- ✓ Reinstall the belt covers
- ✓ Reconnect spark plug wire

Front of Unit

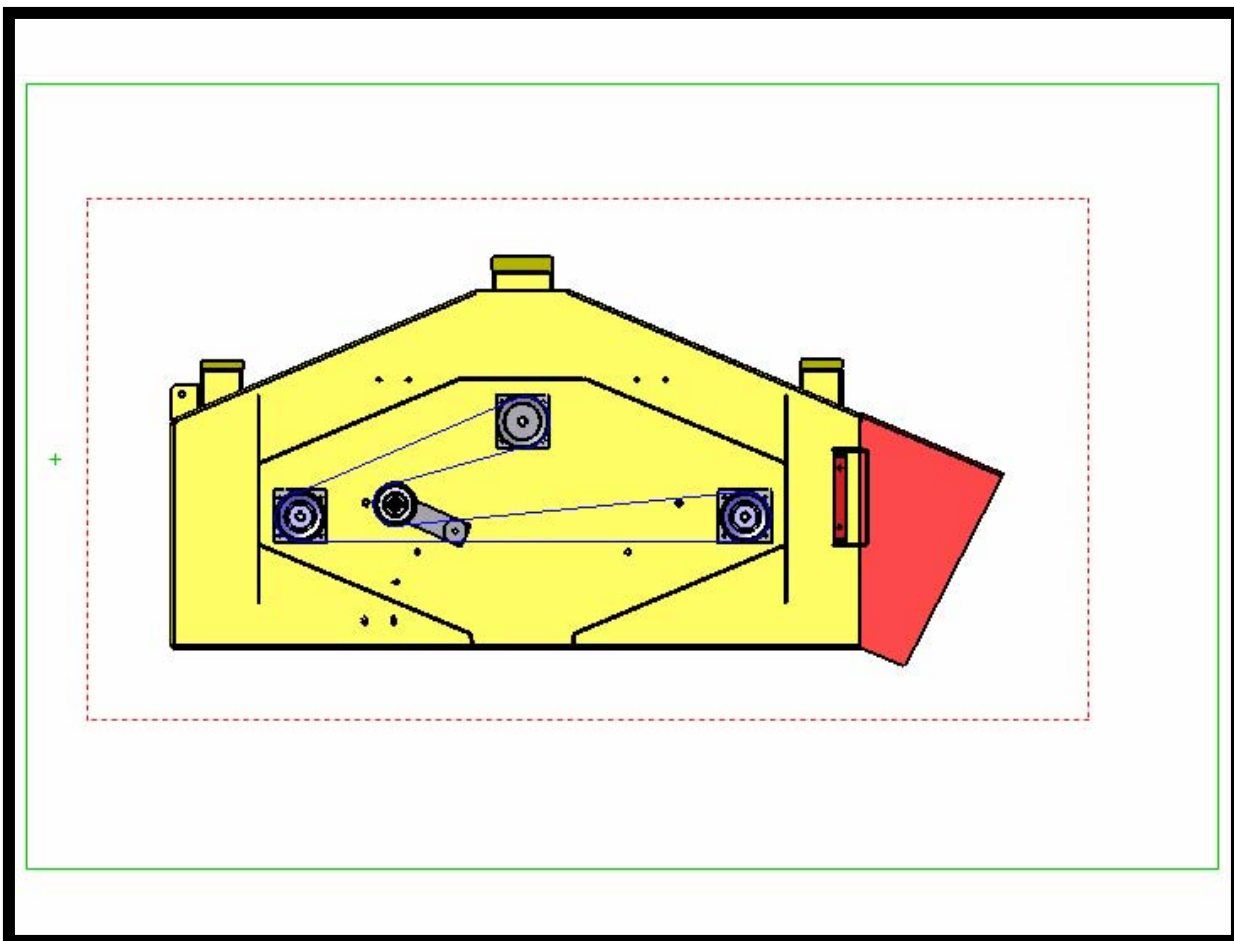

SERVICE & ADJUSTMENTS

Hydro Belt Routing & Replacement

Removal

- ✓ Disconnect spark plug wire
- ✓ Apply parking brake
- ✓ Disconnect wiring from electric clutch
- ✓ Remove clutch stop weldment (9973TK)
- ✓ Remove the engine to deck belt
- ✓ Disconnect idler spring
- ✓ Disconnect tension idler
- ✓ Remove belt from the engine pulley and from the Hydro pulleys

Replacement

- ✓ Install new belt by placing it around the engine pulley and the hydro pulleys. Refer to routing diagram below.
- ✓ The belt will be loose at this time
- ✓ Tightly secure the belt tension back to its original position
- ✓ Reinstall the belt from the engine to the deck
- ✓ Reconnect wiring to the electric clutch
- ✓ Reconnect spark plug wire

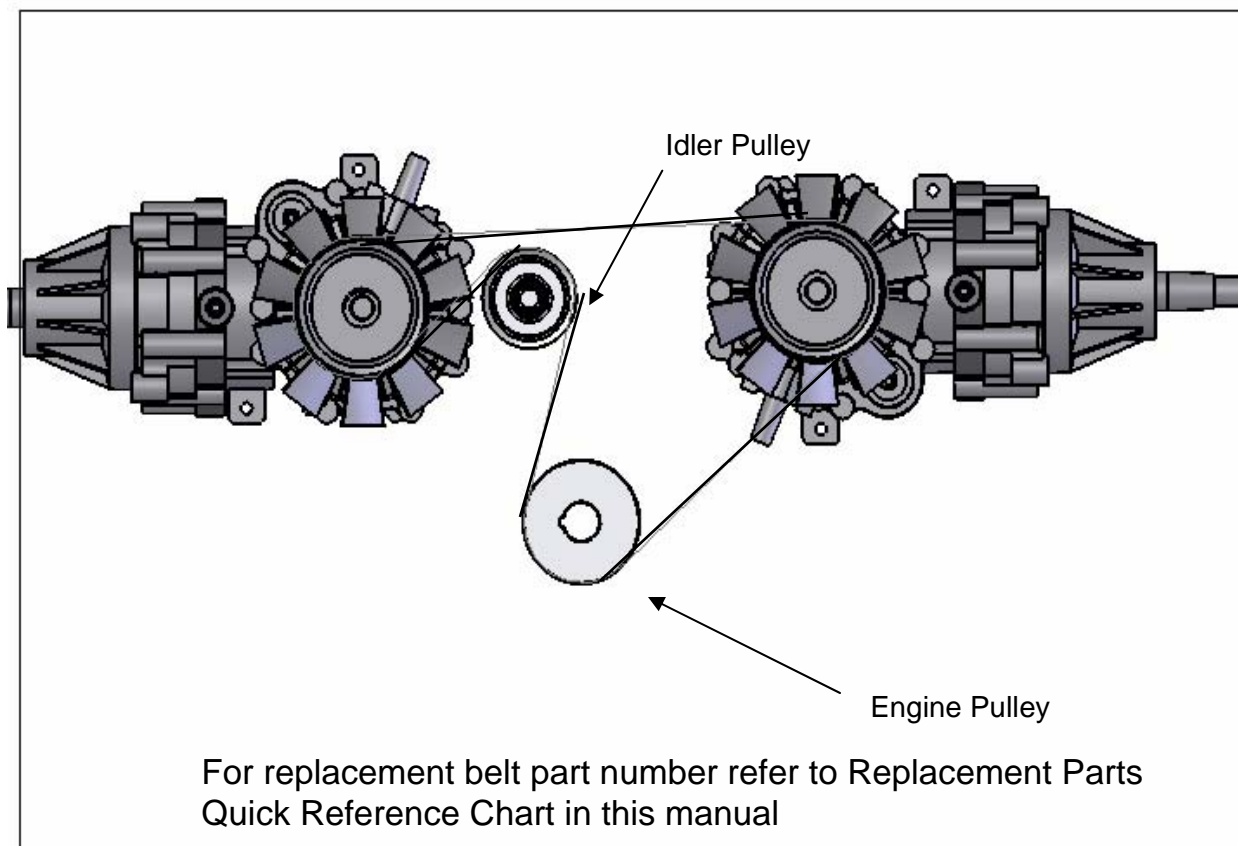

SERVICE & ADJUSTMENTS

Engine to Deck Belt

Removal

- ✓ Apply parking brake
- ✓ Lower the deck to its lowest position
- ✓ Disconnect tension idler
- ✓ Remove belt from the mower deck and the electric clutch

Replacement

- ✓ Install new belt by placing it around the electric clutch and route it through the idler and around the deck pulley. Refer to routing diagram below.
- ✓ The belt will be loose at this time
- ✓ Tightly secure the belt tension back to its original position

Seat Adjustment

- ✓ The Swisher ZT2460 is equipped with a 6" range sliding seat.
- ✓ Release the tension on the seat adjustment lever by pushing the yellow tip lever to the left. See features section in this manual
- ✓ Using your own weight, slide the seat to the desired position
- ✓ Release the lever

SERVICE & ADJUSTMENTS

Parking Brakes

- ✓ The Swisher ZT2460 is equipped with an Automatic Parking Brake system on each control handle.
- ✓ When the control handles are in the out most position the parking brakes are on.
- ✓ Adjustment for the system is located on the ends of the brake cable at the hydro pan & frame
- ✓ Raise the rear wheel off the ground.
- ✓ Disengage the hydro to be adjusted with the hydro release handle at the rear of the unit
- ✓ Adjust so that the brake is not on when the handles are in the operator position. The wheel should turn freely.
- ✓ The wheel should not turn when the handle is move to the engaged or outward position.
- ✓ To tighten the brake, turn the adjustment nuts towards the end of the cable.
- ✓ Recheck adjustment with control handle
- ✓ Lower unit back to the ground
- ✓ Reengage the hydro at the rear of the unit



WARNING

When it is necessary to raise the mower for any repair or service, use jackstands to provide adequate support. DO NOT rely on hydraulic or mechanical jacks

WIRING HARNESS

ZT 2460

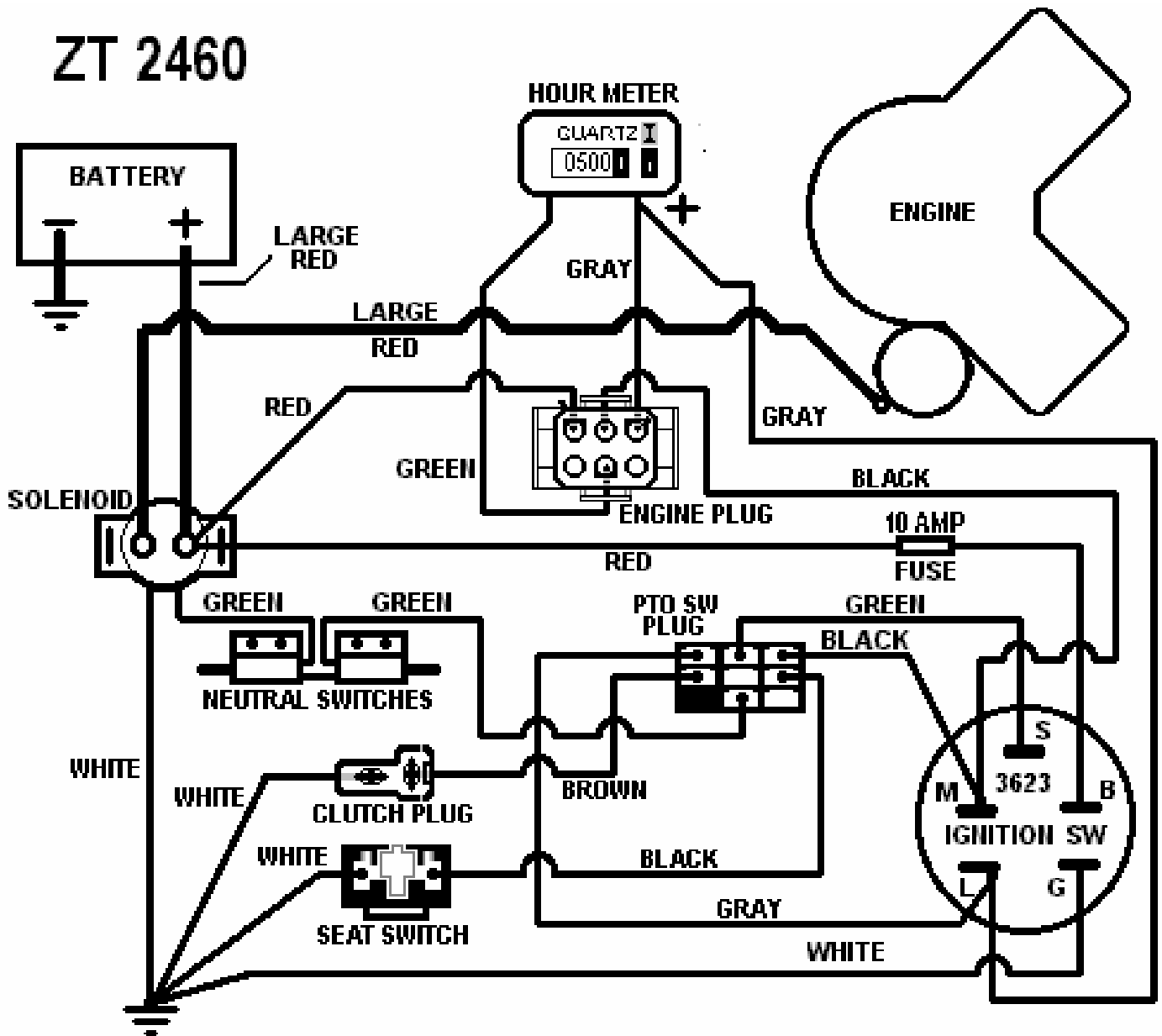

Item #	Description	Part #
1	24HP B&S Engine	N/A
2	Frame Pan	9999TK
3	Lift Support Plate (right)	9937TK
4	Lift Support Plate (left)	9936TK
5	1/3-13 X 2 GR5 Bolt	NB509
6	2 1/2 Cable Pulley	10211
7	1 1/2 Cable Pulley	5542
8	1/2-13 Nut	NB213Z
9	1/2-13 Nyloc Nut	NB281
10	Lock Plate	9922TK
11	5/16-18 X 3/4 Serrated Flg Bolt	NB596
12	5/16-18 Jam Nut	NB173
13	5/16-18 X 1 1/4 Serrated Flange Bol	NB253
14	Rear Deck Lift Cable	9947
15	Linkage Tab	9958TK
16	Deck Lift Weldment	9933TK
17	5/16-18 Nyloc Nut	NB181

PARTS BREAKDOWN

Item #	Description	Part #
18	Front Deck Lift Cable	9948
19	Height Adjust Handle	9952TK
20	Height Adjust Handle Grip	7826
21	Front Handle Cover	9941TK
22	5/16-18 X 2 1/2 GR5 Bolt	NB138
23	5/16-18 X 3 GR2 Bolt	NB563
24	5/16 SAE Washer	NB275
25	Deck Lift Handle Spring	10535
26	5/16-18 Serrated Flange Nut	NB170
27	5/16-18 X 1 1/2 Serrated Flange Bol	NB252
28	Solenoid Bracket Painted	9913TK

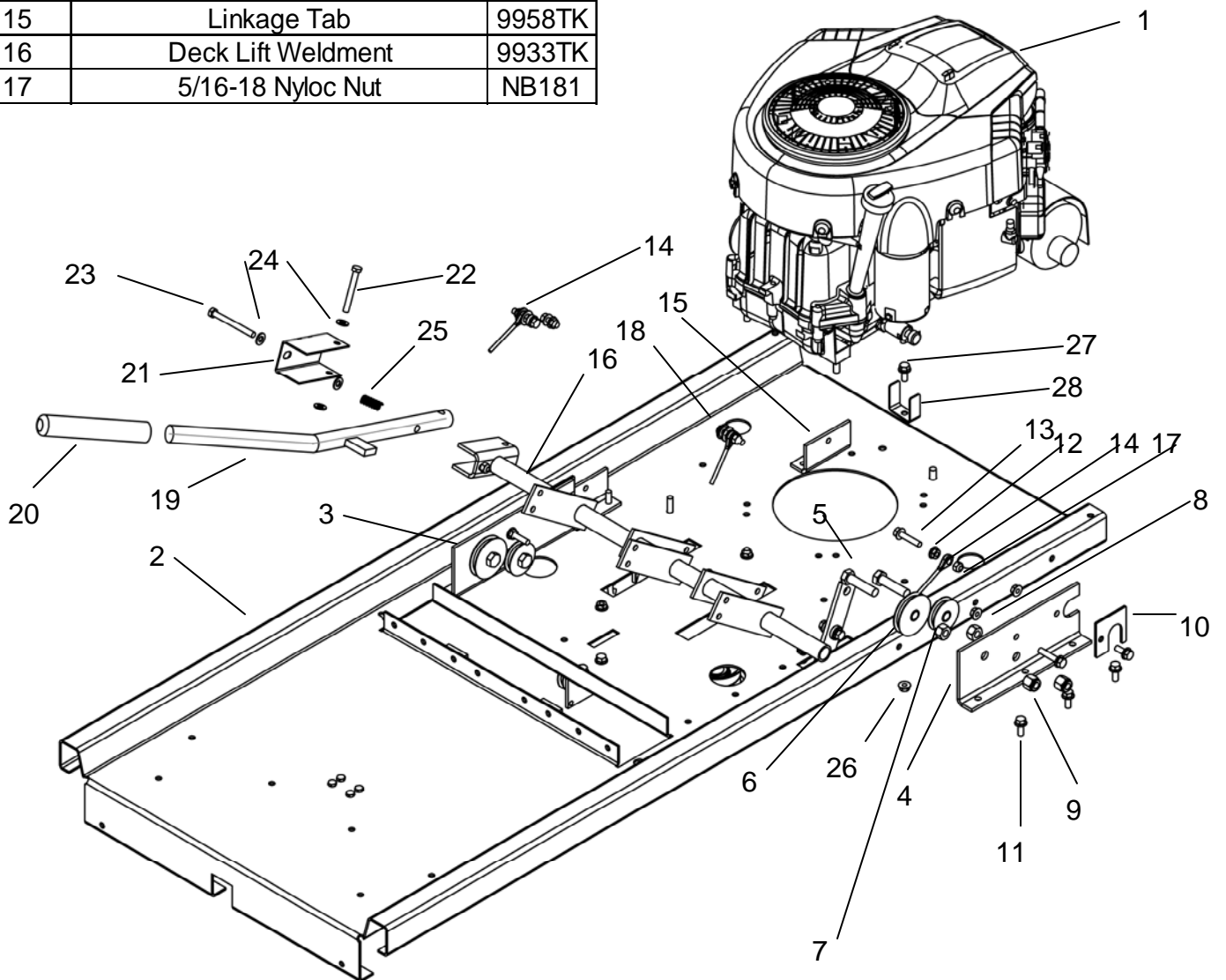

Item #	Description	Part #
1	24 HP B&S Engine	N/A
2	5/16-18 Serrated Flange Nut	NB170
3	Spacer Engine Pulley	BB105SL
4	Motor Pulley 3.25"	3753
5	1/4 X 1/2 Key Stock	4258
6	Engine Pulley Spacer Short .687	689S
7	Electric Clutch	3813
8	Washer Belleville Engine Pulley	699
9	7/16-20 X 3.25 HCF GR5 ZP	NB705
10	5/16-18 X 1 1/4 Serrated Flange Bolt	NB253
11	Oil Drain Valve	AS122
12	Oil Drain Valve Cap	AS123

Not Shown

Description	Part #
Solenoid Assembly	9043
Wiring Harness	10264

PARTS BREAKDOWN

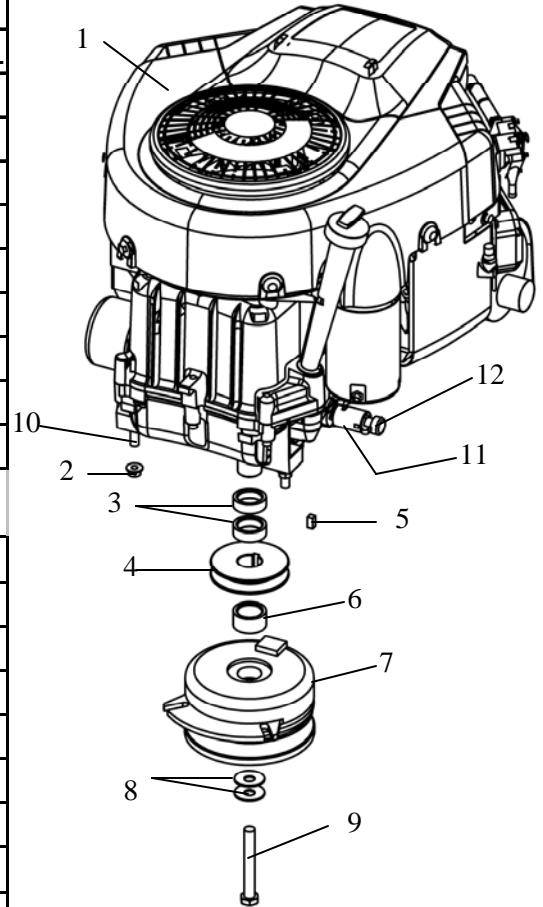

ENGINE ASSEMBLY

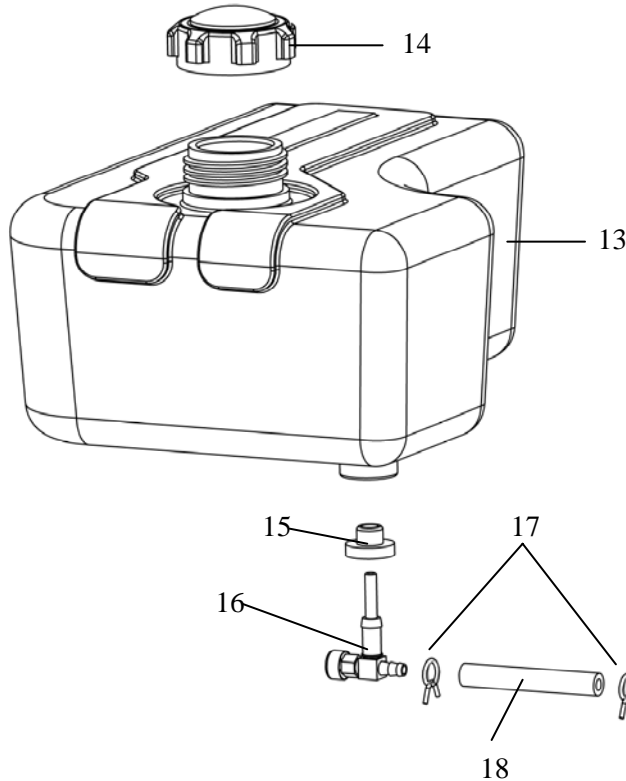

Item #	Description	Part #
13	Fuel Tank	AS100
14	Cap	6102NC
15	Grommet	AS119
16	Fuel Shut Off Valve	AS120
17	Fuel Line Clamp	6FLC
18	1/4" Fuel Line	AS140
19	Check Valve 1/4"	10265

GAS TANK ASSEMBLY

PARTS BREAKDOWN

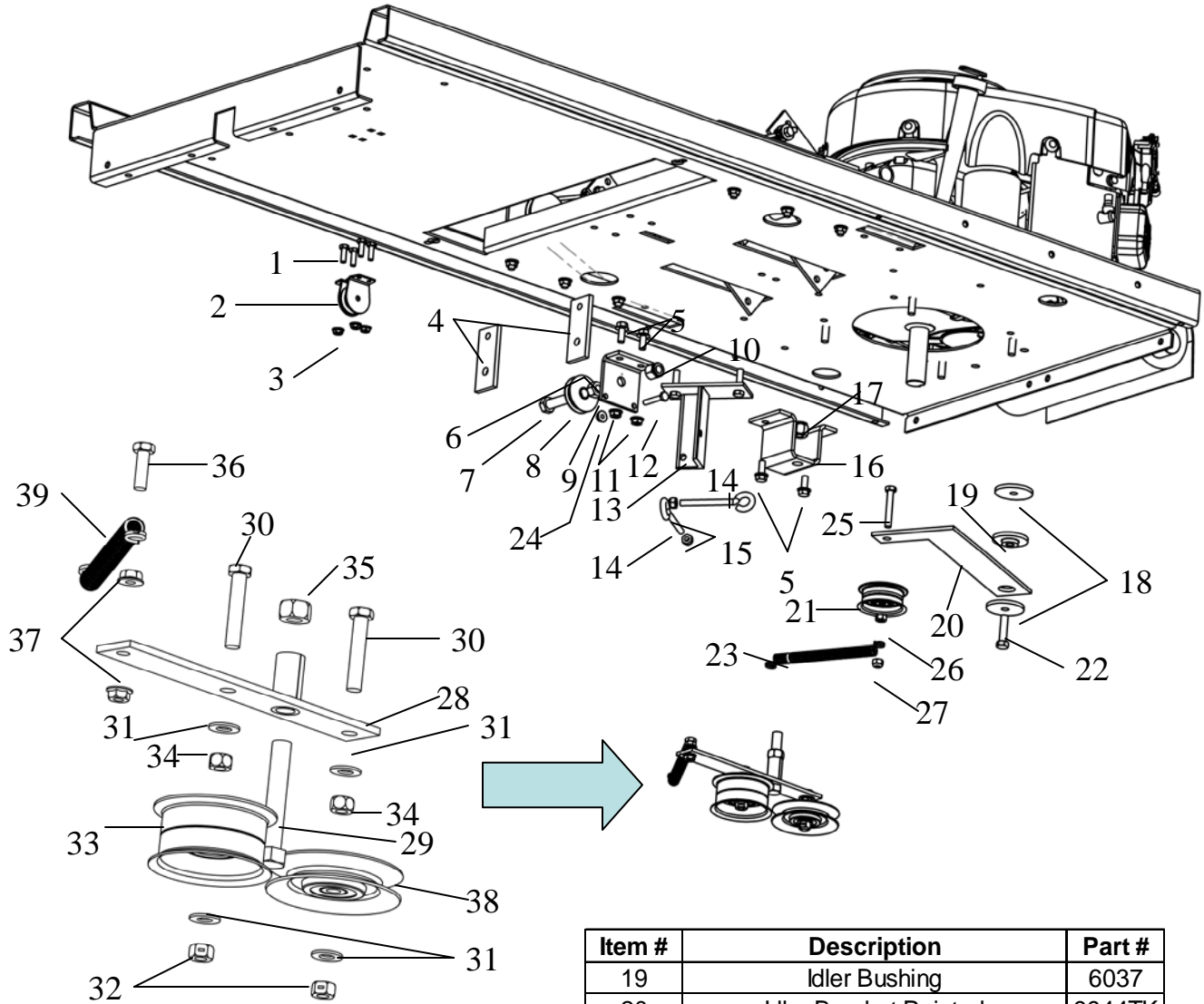

Item #	Description	Part #
1	1/4- 20 X 3/4 Carriage Bolt	10547
2	1 1/2" Block Pulley	10728
3	1/4- 20 Serrated Flg Nut	NB524
4	Spring Assist Bracket	9926TK
5	5/16- 18 X 3/4 Serrated Flange Bolt	NB596
6	Pulley Mount Tab	9963TK
7	1/2- 13 X 2 GR5 Bolt	NB509
8	Cable Pulley	5542
9	1/3- 13 GR2 Nut	NB213Z
10	1/2- 13 Nyloc Nut	NB281
11	5/16- 18 Serrated Flange Nut	NB170
12	1/4- 20 X 1 1/2 GR2 Bolt	NB162
13	Tension Bracket	9918TK
14	5/16- 18 X 3 1/2 center of eye eye bolt	NB315
15	5/16- 18 Nyloc Nut	NB181
16	Belt to Deck Idler Bracket	9957TK
17	1/2- 13 Nyloc Nut	NB281
18	Idler Spacer	6040

Item #	Description	Part #
19	Idler Bushing	6037
20	Idler Bracket Painted	9944TK
21	Idler Pulley OD-2.16", ID-3/8"	B27
22	3/8-16 X 1 1/2 HCC GR5 ZP	NB107
23	Clutch Rod Spring T60	682S
24	1/4-20 Flange Nut	NB524
25	5/16 Nylon Bushing	NB198
26	3/8-16 2-Way Lock Nut	NB280
27	3/8-16 Nyloc Nut	NB182
28	Lower Belt Idler Arm	3691TK
29	1/2-13 X 3 HCC GR5 Bolt ZP	NB131
30	3/8-16 X 2 HTC GR2 ZP	NB231
31	3/8 SAE Washer	NB272
32	3/8-16 2-Way Lock Nut	NB280
33	Idler Pulley OD-2.75", ID-3/8"	7509
34	3/8-16 HNC GR2 ZP	NB212
35	1/2-13 Nut GR2 ZP	NB213Z
36	5/16-18 X 1 HCC GR5 ZP	NB501
37	5/16-18 Serrated Flng Nut	NB170
38	Idler Pulley V OD-3.54", ID-3/8"	3622
39	Clutch Rod Spring T60	682S

PARTS BREAKDOWN

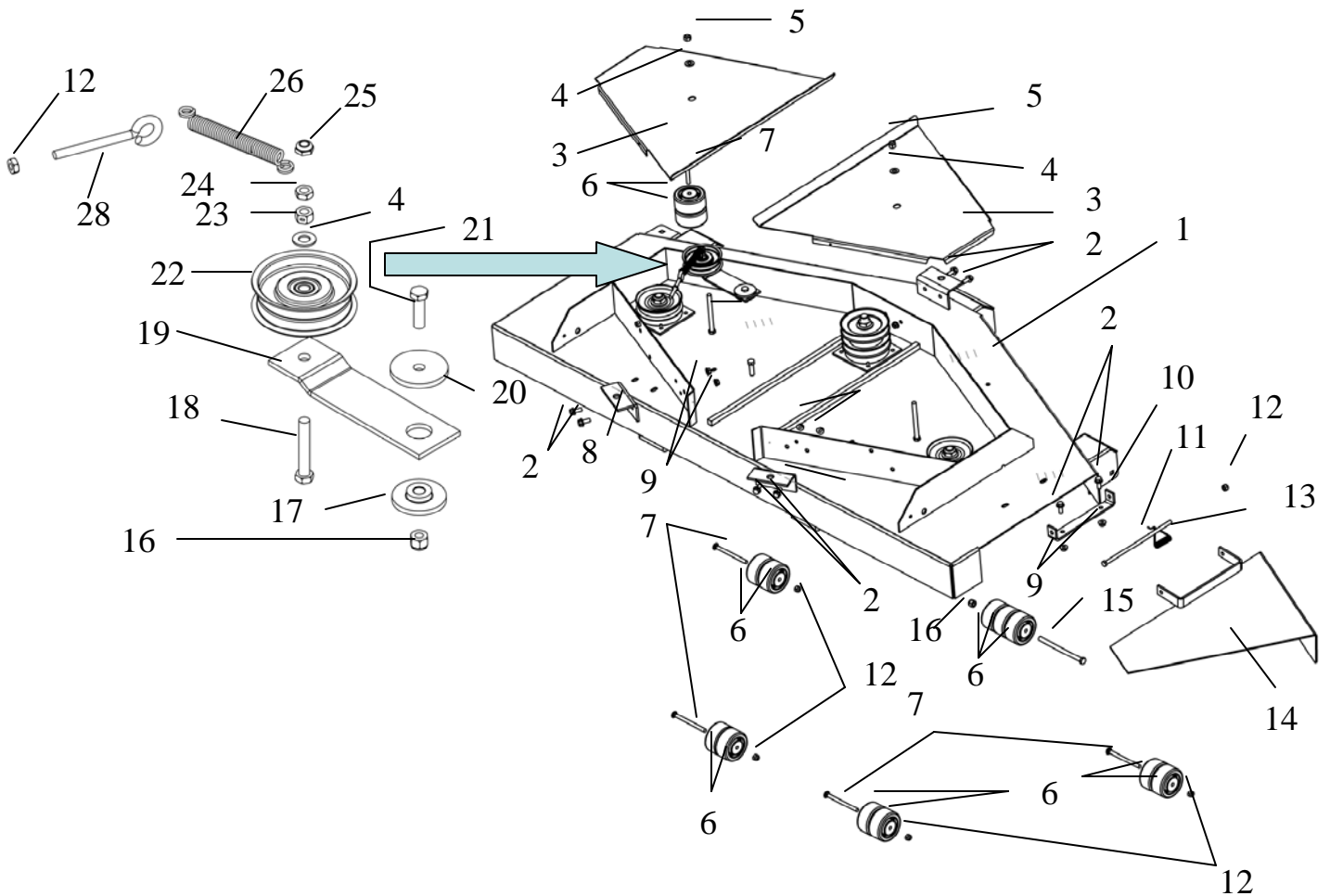

Item #	Description	Part #
1	60 ZT Deck weldment - painted	9901 TK
2	5/16-18 x 3/4 Serr flange bolt	NB596
3	Belt Cover - painted	6025TK
4	3/8 SAE washer	NB272
5	3/8-16 nyloc nut	NB182
6	Anti-scalp roller 3/8 ID	AS001
7	5/16-18 serrated flange nut	NB101
8	Deck Hanger - painted	9938TK
9	5/16-18 serrated flange nut	NB170
10	Chute mount-painted	6030TK
11	5/16-18 x 8 1/2 HCC GR2 ZP	NB136
12	5/16-18 nyloc nut	NB181
13	Torsion spring- bent leg	9100
14	Discharge Chute Weldment-painted	9902TK
15	3/8-16 x 5 1/2 GR5 ZP	NB575
16	3/8-16 nyloc nut	NB182
17	Idler Bushing	6037
18	3/8-16 x 2 1/4 HTC GR5 ZP	NB693
19	Idler Arm -painted	6141TK
20	Idler Spacer	6040
21	3/8-16 x 1 1/2 HCC GR5 ZP	NB107
22	Idler Pulley OD 3.25, ID 3/8	B527

PARTS BREAKDOWN

Item #	Description	Part #
1	3/4-16 Nut	NB175
2	Belleville Washer	AS155
3	Pulley 4 1/2"	B4104TK
4	Spacer	6065PM
5	3/4 ID X 1 1/4 OD 18 GA Washer	NB179
6	Center Blade Driver	10541
7	Outer Blade Driver	10540
8	3/4 ID X 1 3/4 OD Flat Washer	B98W
9	Blade Mount Plate	9008
10	3/8-24 Two Way Lock Nut	NB216
11	Blade	3293
12	3/8-24 X 1 1/2 Bolt	NB167
13	Belleville Washer	NB607
14	Blade Bearing	B98
15	7" Blade Driver Shaft	9075
16	5" Blade Driver Shaft	9077
17	Blade Driver Housing	10539

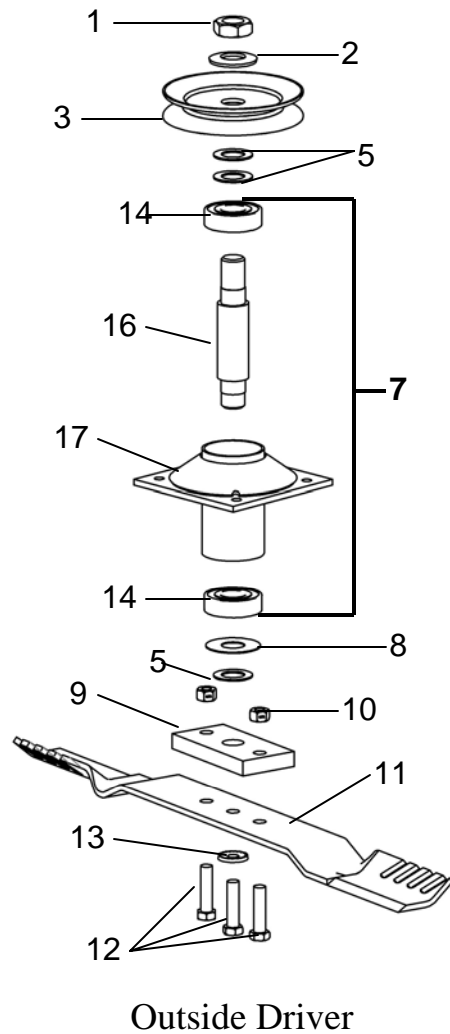
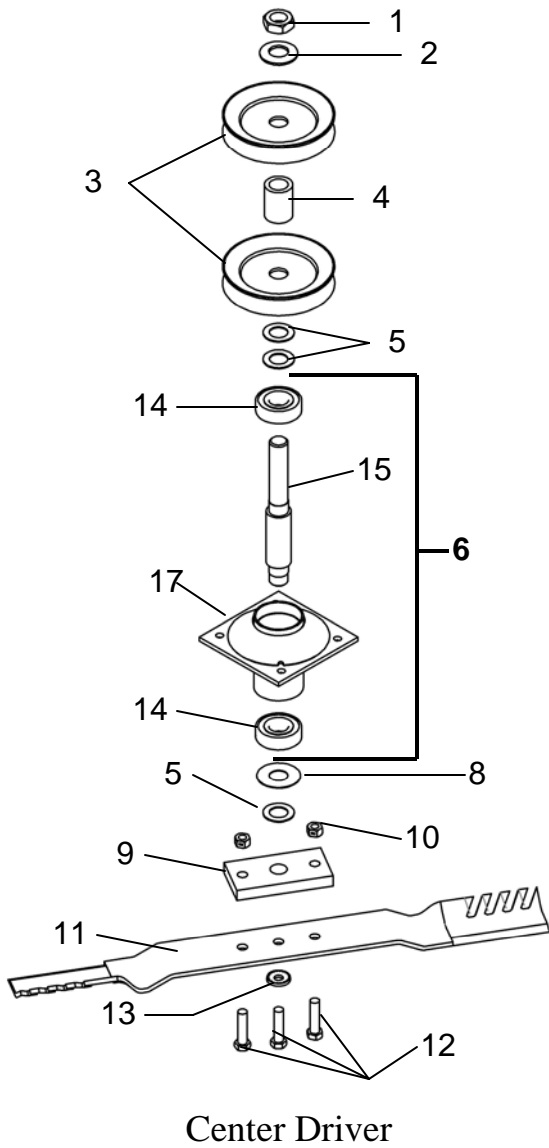

PARTS BREAKDOWN

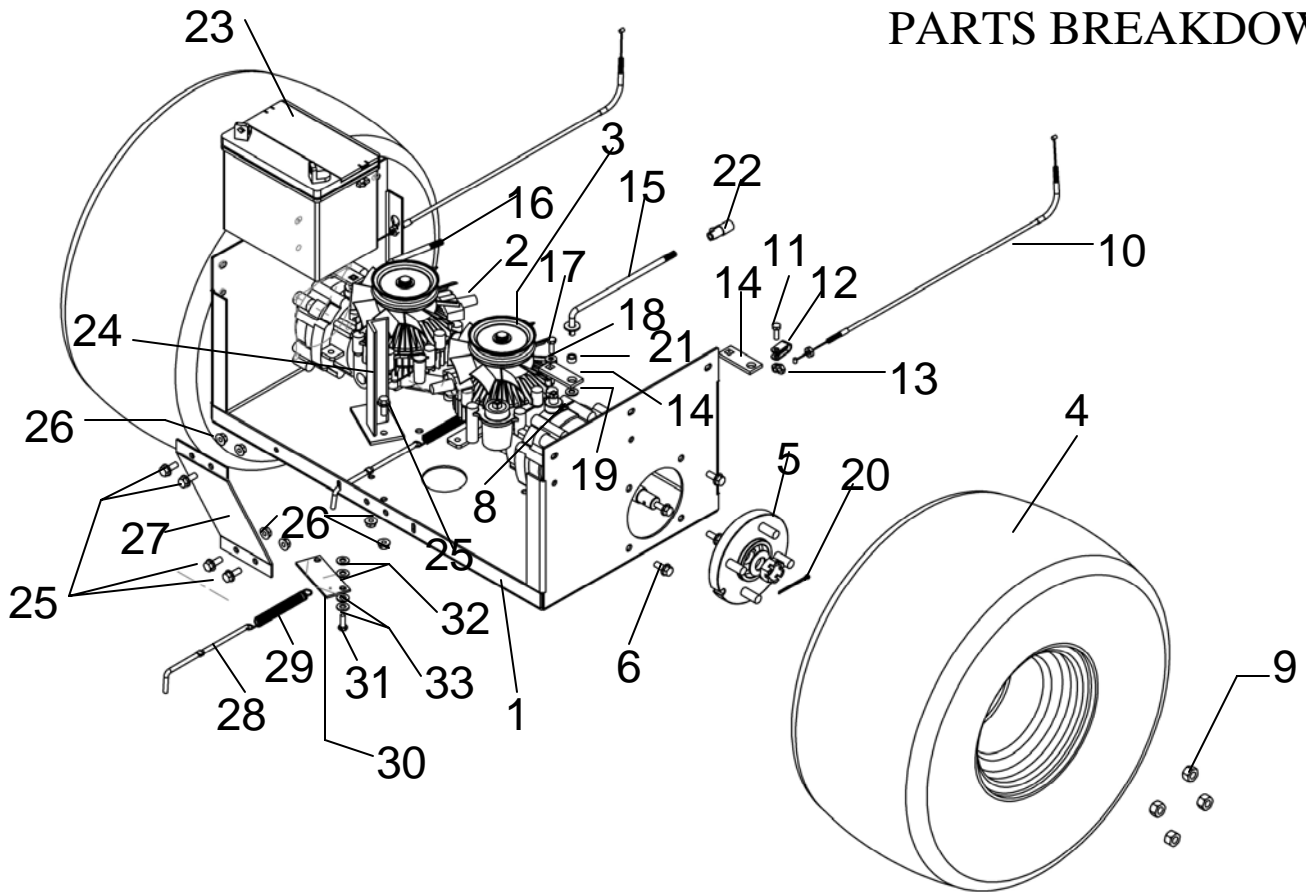

Item #	Description	Part #	Item #	Description	Part #
1	Hydro Pan Weldment	9935TK	23	Battery	
2	Eaton Hydro w/ Resv & Tank	10268	24	Clutch stop weldment - painted	9973TK
3	Eaton Hydro w/ Resv & Tank & Ext	10269	25	5/16-18 x3/4 serr flange bolt	NB596
4	Tire & Wheel 20 x 10 x 8	3756	26	5/16-18 serrated flange nut	NB170
5	Wheel Hub Assembly	9920	27	Rear Stabilizer-Painted	9946TK
6	3/8-16x 3/4 serr flange rolok serr	10545	28	Hydro release handle	9923
7	1.5 x .761 x .098 x .134 Belv washer	AS155	29	Spring for Idler Arm	BRS6
8	5/64 x 3/4 cotter pin	NB519	30	Hydro release plate - Painted	9924TK
9	Wheel Hub Lug Nut 1/2-20	2203LN	31	5/16-18x1 Rolock screw	10543
10	Parking Brake Cable Assembly	9976	32	5/16 sae washer	NB275
11	1/4-20 x3/4 GR5 ZP	NB250	33	5/16-7/10 x .006 waste water	10544
12	Clutch cable clevis T44ch	9023MOD	NOT SHOWN		
13	1/4-20 nylok nut	NB180		Battery Hold Down	BHOLD
14	Shift linkage- Painted	9919TK		1/4-20 X 1 1/2 atc gr2 zp	NB162
15	Hydro linkage Right Weldment	9929		1/4-20 Nylok nut	NB180
16	Hydro linkage Left Weldment	9928		1/4 SAE Washer	NB274
17	1/4-28 x 3/4 GR5 ZP	NB620		1/4-20 kep nut	NB203
18	1/4 SAE Washer	NB274		Battery Cable 10" Red	BCSR
19	5/16 SAE Washer	NB275		Battery Cable 10" Black	BCSR
20	1/8 x 2 Cotter Pin	NB633		Battery Cable Boot	BCBT
21	Latch Pin Bushing	78392			
22	Ball Linkage right (silver)	NB263			

PARTS BREAKDOWN

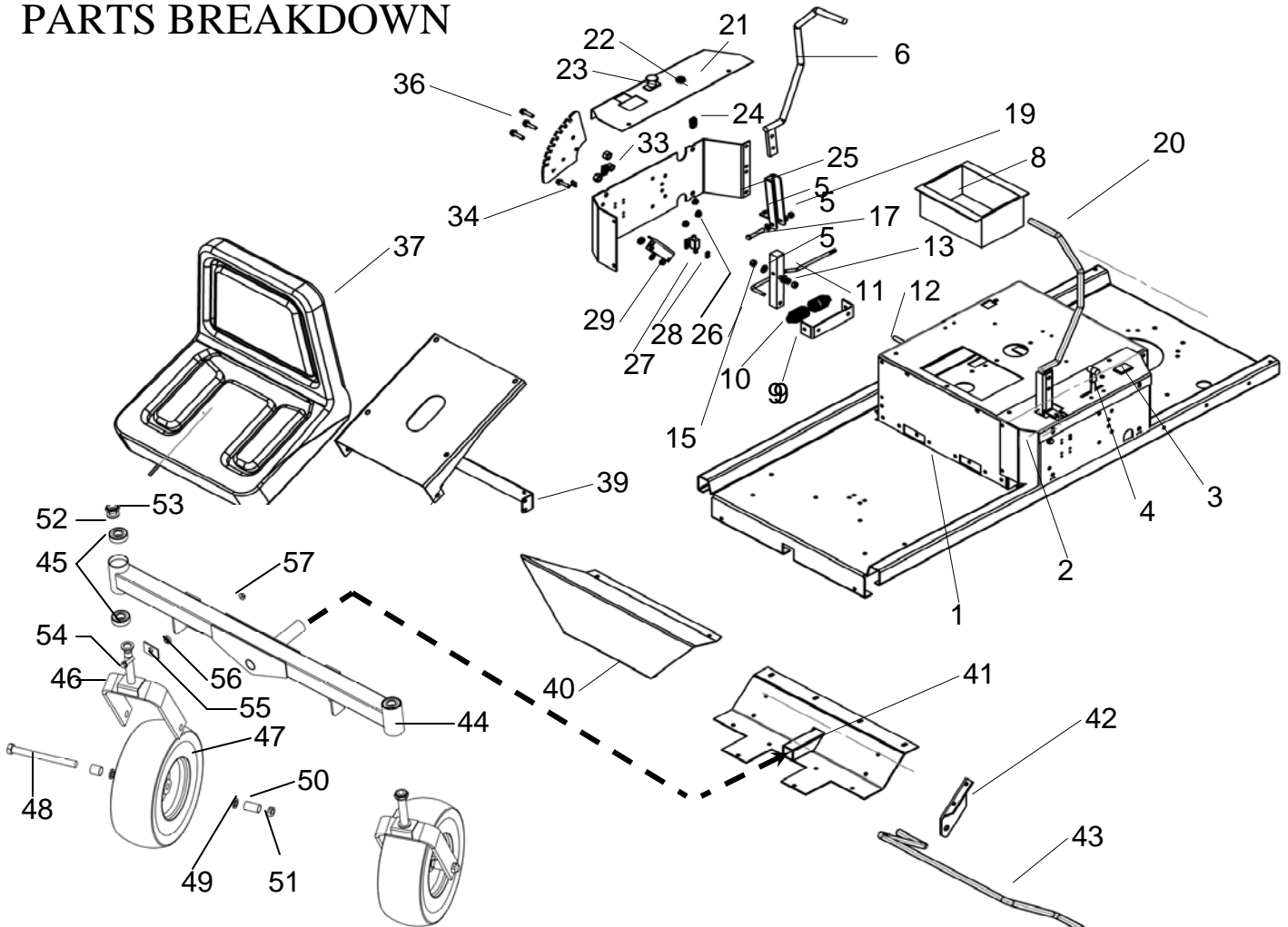

Item #	Description	Part #
1	Seat Base	9998TK
2	Control Panel	9991TK
3	Hour Meter	3803
4	Throttle Control 35"	3788
5	Handle Pivot	9985TK
6	Handle Weldment	9932TK
7	5/16-18 X 1 Serrated Flange GR5 Bolt	10548
8	Tool Box	9956TK
9	Neutral Bracket	9992TK
10	Tapered Spring	3609
11	Steering Linkage Control Arm	9927
12	3/8-16 X 2 1/4 GR5 Bolt	NB699
13	3/8-16 GR2	NB212
14	3/8-16 Jam Nut	NB174
15	3/8 SAE Washer	NB272
16	3/8-16 2-Way Lock Nut	NB280
17	5/16-18X2 GR5 Bolt	NB507
18	5/16 SAE Washer	NB275
19	5/16-18 Nyloc Nut	NB181
20	Handle Weldment	9930TK
21	Control Panel Right	9990TK
22	Key Switch	3623
23	PTO Switch	3605
24	Tinnerman Clips 5/16-18 Heavy Duty	3669
25	Side Plate	9996TK
26	5/16-18 Serrated Flange Nut	NB170
27	Return to Neutral Switch	3695
28	8-32 Kep Nut	NB201
29	Safety Switch Rocker Arm	9925TK

30	5/16-18 Nyloc Nut	NB181
31	5/16 SAE Washer	NB275
32	Spacer	B99S
33	1/2-13 GR2 Nut	NB213Z
34	8-32X 1/2 Phil Truss Screw	NB197
35	Control Panel Right	9990TK
36	5/16-18 X 1 1/4 Serrated Flange Bolt	NB253
37	ZT Seat 18"	10570
38	Seat Mount	9984TK
39	Seat Bracket	3807TK
40	Foot Plate	9995TK
41	Pivot Plate Housing Weldment	9954TK
42	Deck Stabilizer-Left	9950TK
	Deck Stabilizer-Right	
43	Deck Stabilizing Bar	9949
44	Pivot Axle Weldment-Painted	9994TK
45	Blade Bearing	B98
46	Textured Black Caster T50	665TK
47	Tire/Wheel Slick 4.10x3.5-5 5/8 Bearing	3010
48	5/8-11 X 7 HCC GR5 ZP	nb624
49	5/8 ID X 1 OD 10 GA Washer	nb178
50	Wheel Spacer 1"	3395
51	5/8-11 2 Way Lock Jam Nut	nb595
52	13/16 X 1 1/4 X 1/8 Washer	nb195
53	3/4-16 Jam Nylok Nut	nb122
54	5/16-18 X 1 Serrated Flange GR5 2P	10548
55	Axle Washer-Painted	9915tk
56	Spacer	B99S
57	5/16-18 Serrated Flng Nut	NB170
	NOT SHOWN	
	Arm Rest Kit	10571
	Mat for Pan	10729
	Mat for Foot Plate	105549
	60" Choke Cable	9914

TROUBLESHOOTING

PROBLEM	CAUSE	CORRECTION
Engine Will Not Start	<ol style="list-style-type: none"> 1. Out of fuel 2. Engine not "choked" properly 3. Engine flooded 4. Bad spark plug 5. Dirty air filter 6. Dirty fuel filter 7. Water in fuel 8. Loose or damaged wiring 9. Carburetor out of adjustment 10. Engine valves out of adjustment 11. Extreme cold conditions 	<ol style="list-style-type: none"> 1. Fill fuel tank 2. Choked engine and attempt to restart 3. Wait several minutes before attempting to restart. 4. Replace spark plug 5. Clean or replace air filter 6. Replace fuel filter 7. Drain fuel tank & carburetor, refill tank with fresh gas and replace fuel filter 8. Check all wiring 9. See Engine Manual 10. Contact an authorized service center 11. See Engine Manual
Engine Hard To Start	<ol style="list-style-type: none"> 1. Bad spark plug 2. Dirty air filter 3. Dirty fuel filter 4. Weak or dead battery 5. Carburetor out of adjustment 6. Engine valves out of adjustment 7. Loose or damaged wiring 8. Stale or dirty fuel 	<ol style="list-style-type: none"> 1. Replace spark plug 2. Clean or replace air filter 3. Replace fuel filter 4. Recharge or replace battery 5. See Engine Manual 6. Contact an authorized service center 7. Check all wiring 8. Drain fuel tank & refill with fresh gasoline
Engine Will Not Turn Over	<ol style="list-style-type: none"> 1. Directional handles not in correct position 2. PTO engaged 3. Weak or dead battery 4. Blown fuse 5. Corroded battery terminals 6. Loose or damaged wiring 7. Faulty ignition switch 8. Faulty solenoid 9. Faulty operator presence switch/switches 	<ol style="list-style-type: none"> 1. Place handles in the out most position 2. Push PTO switch down 3. Recharge or replace battery 4. Replace fuse 5. Clean battery terminals – See battery section of this manual 6. Check all wiring 7. Check/replace ignition switch 8. Check/replace solenoid 9. Contact an authorized service center
Engine Clicks but Will Not Start	<ol style="list-style-type: none"> 1. Weak or dead battery 2. Corroded battery terminals 3. Loose or damaged wiring 4. Faulty solenoid 	<ol style="list-style-type: none"> 1. Recharge or replace battery 2. Clean battery terminals – See battery section of this manual 3. Check all wiring 4. Check/replace solenoid

TROUBLESHOOTING Continued

PROBLEM	CAUSE	CORRECTION
Loss of Power	<ol style="list-style-type: none"> 1. Cutting too much grass/ too fast 2. "Choke" position 3. Buildup of grass, leaves and trash under deck. 4. Dirty air filter 5. Low oil level/dirty oil 6. Faulty spark plug 7. Dirty fuel filter 8. Stale or dirty fuel 9. Water in fuel 10. Spark plug wire loose 11. Dirty engine air screen/fins 12. Dirty/clogged muffler 13. Loose or damaged wiring 14. Carburetor out of adjustment 15. Engine valves out of adjustment 16. Loose drive belt 	<ol style="list-style-type: none"> 1. Set in High Cut (position 8)/reduce speed 2. Push choke control in 3. Clean underside of mower deck 4. Clean or replace air filter 5. Check oil level/change oil 6. Clean and re-gap or change plug 7. Replace fuel filter 8. Drain fuel tank & refill tank with fresh gas 9. Drain fuel tank & carburetor, refill tank with fresh gas and replace fuel filter 10. Connect and tighten spark plug wire 11. Clean engine air screen/fins 12. Clean/replace muffler 13. Check all wiring 14. See Engine Manual 15. Contact an authorized service center 16. Adjust idler/replace belt
Excessive Vibration	<ol style="list-style-type: none"> 1. Worn, bent or loose blade 2. Bent blade driver 3. Loose/damage part or parts 4. Faulty blade driver assembly 	<ol style="list-style-type: none"> 1. Replace blade. Tighten blade bolt. 2. Replace blade driver 3. Tighten loose part or parts. Replace damaged parts. 4. Replace blade driver assembly
Engine backfires when turning engine OFF	<ol style="list-style-type: none"> 1. Engine throttle control not set at "SLOW" position for 30 seconds before stopping engine. 	<ol style="list-style-type: none"> 1. Move throttle control to "SLOW" position and allow to idle for 30 seconds before stopping engine
Unit Does not Travel in a straight line	<ol style="list-style-type: none"> 1. Incorrect tire pressure 	<ol style="list-style-type: none"> 1. Check tire pressure (See Specifications)

TROUBLESHOOTING Continued

PROBLEM	CAUSE	CORRECTION
Poor cut - uneven	<ol style="list-style-type: none"> 1. Worn, bent or loose blade 2. Mower deck not level 3. Buildup of grass, leaves and trash under deck. 4. Bent deck 5. Faulty Blade driver assembly 	<ol style="list-style-type: none"> 1. Replace blade. Tighten blade bolt 2. Level deck. See section in this manual 3. Clean underside of mower deck 4. Replace deck 5. Replace blade driver assembly
Battery will not charge	<ol style="list-style-type: none"> 1. Bad battery 2. Poor cable connections 3. Faulty solenoid 	<ol style="list-style-type: none"> 1. Replace battery 2. Check/clean all connections. See section in this manual 3. Replace solenoid
Loss of drive	<ol style="list-style-type: none"> 1. Bypass linkages in the bypass position 2. Hydro belt worn, damaged, or broken 3. Idler spring loose or broken 	<ol style="list-style-type: none"> 1. Make sure that the bypass linkages are in the drive or engaged position. Located at the rear of the machine. Refer to decal on the rear of the unit. 2. Replace Hydro belt. 3. Replace Idler spring
		36

Mower Identification

Each mower has its own model number. Each engine has its own model number. The model number for the mower will be found under the seat. The model number for the engine will be found on the top of the blower fan housing. All mower parts listed herein may be ordered directly from Swisher Mower & Machine Co. Inc. or your nearest Swisher dealer. All engine parts may be ordered from the nearest dealer of the engine supplied with your mower.

Unauthorized Replacement Parts

Use only Swisher replacement parts. The replacement of any part on this unit with anything other than Swisher authorized replacement part may adversely affect the performance, durability and safety of this unit and may void the warranty. Swisher disclaims liability for any claims or damages, whether warranty, property damage, personal injury or death arising out of the use of unauthorized replacement parts.

WHEN ORDERING PARTS, PLEASE HAVE THE FOLLOWING INFORMATION AVAILABLE:

- Date Purchased _____
- Purchased From_____
- PRODUCT – ZT2460
- SERIAL NUMBER - _____
- MODEL NUMBER - _____
- ENGINE MODEL NUMBER - _____
- TYPE - _____
- PART NUMBER WITH PAINT CODE_____
- *PART DESCRIPTION_____

SWISHER MOWER & MACHINE CO. INC.
1602 CORPORATE DRIVE
P.O. BOX 67
WARRENSBURG, MO 64093

Swisherinc.com

TELEPHONE - 1-800-222-8183
FAX - 1-660-747-8650

Replacement Parts

Quick Reference

Swisher Part #	Part Description
9947	Rear Deck Lift Cable
9948	Front Deck Lift Cable
AS069	Fuse 10 Amp
6046	47" Hydro Belt
3756	20 x 10 x 8 Rear Tire
5058	122" Deck Belt
3293	20.5 Mulching Blade
10263	83" Engine to Deck Belt
10540	Blade Driver Assembly (outside)
10541	Blade Driver Assembly (center)



CAUTION

Use extreme care when working on machinery.

Before performing any maintenance, turn off engine, allow the unit to cool & remove the key. Disconnect spark plug wire.

Set Parking Brake by placing the control handles in the neutral or outward position.

Do not wear watch or jewelry. Do not wear loose fitting clothes. Observe all common safety practices with tools.

Maintenance Log

Date Oil Changed	Date Changed Belts	Date Blades Sharpen or Changed	Notes



SWISHER HISTORY

Back before electricity came to rural Missouri Max Swisher was producing lawn mowers from his mother's chicken house. Max never liked to mow grass. He installed a gearbox on his family's lawn mower creating a self-propelled unit. By tying one end of a rope to the mower and the other end to a tree in the center of the yard the mower circled the tree, shortening the rope and guiding the mower in concentric circles. Max enjoyed relaxing under a shade tree while his invention did all the work.

Max had designed his first self-propelled rotary lawn mower to do his dirty work for him. Neighbors noticed his new invention and began asking him to make more. Today, 60 years later, Swisher Mower and Machine Company, Inc. is still producing innovative lawn and garden and ATV/UTV equipment designed to give us all more "relaxing in the shade" time.

Swisher products have been featured nationally on television programs such as Regis and Kathie Lee and seen in publications like ATV Magazine, Country Journal, Popular Mechanics Magazine and others. In January 2000 Popular Mechanics Magazine named Max's zero turning radius riding mower one of the 20th century's top household inventions.

Swisher offers value and function in its products to meet your grounds maintenance needs.

CELEBRATING 60 YEARS OF INNOVATION

1945 - 2005

