

# MC18 PRODUCT REFERENCE GUIDE



**symbol**<sup>®</sup>



**MC18**  
**Product Reference Guide**

*MN000834A01*

*Rev. A*

*June 2014*

© 2014 by Symbol Technologies, Inc. All rights reserved.

No part of this publication may be reproduced or used in any form, or by any electrical or mechanical means, without permission in writing from Symbol Technologies. This includes electronic or mechanical means, such as photocopying, recording, or information storage and retrieval systems. The material in this manual is subject to change without notice.

The software is provided strictly on an “as is” basis. All software, including firmware, furnished to the user is on a licensed basis. Symbol Technologies grants to the user a non-transferable and non-exclusive license to use each software or firmware program delivered hereunder (licensed program). Except as noted below, such license may not be assigned, sublicensed, or otherwise transferred by the user without prior written consent of Symbol Technologies. No right to copy a licensed program in whole or in part is granted, except as permitted under copyright law. The user shall not modify, merge, or incorporate any form or portion of a licensed program with other program material, create a derivative work from a licensed program, or use a licensed program in a network without written permission from Symbol Technologies. The user agrees to maintain Symbol Technologies copyright notice on the licensed programs delivered hereunder, and to include the same on any authorized copies it makes, in whole or in part. The user agrees not to decompile, disassemble, decode, or reverse engineer any licensed program delivered to the user or any portion thereof.

Symbol Technologies reserves the right to make changes to any software or product to improve reliability, function, or design.

Symbol Technologies does not assume any product liability arising out of, or in connection with, the application or use of any product, circuit, or application described herein.

No license is granted, either expressly or by implication, estoppel, or otherwise under any Symbol Technologies, Inc., intellectual property rights. An implied license only exists for equipment, circuits, and subsystems contained in Symbol Technologies products.

---

## Revision History

Changes to the original manual are listed below:

Change	Date	Description
01 Rev. A	06/27/14	Initial release.



# TABLE OF CONTENTS

Revision History .....	ii
------------------------	----

## About This Guide

Introduction .....	xi
Documentation Set .....	xi
Configurations.....	xii
Software Versions.....	xiii
OEM Software.....	xiii
Fusion Software.....	xiii
Chapter Descriptions .....	xiv
Notational Conventions.....	xv
Related Documents and Software .....	xv
Service Information.....	xvi

## Chapter 1: Getting Started

Introduction .....	1-1
Unpacking .....	1-1
Features .....	1-2
Accessories .....	1-4
LED Indicators .....	1-5
Keypad .....	1-5
Getting Started .....	1-6
Connecting the Battery .....	1-6
Charging the Battery .....	1-9
Manual Release of MC18 from the Cradle .....	1-10
Software Release of MC18 from the Cradle .....	1-11
Starting the MC18 .....	1-12
Touch Screens .....	1-13
Data Capture .....	1-13
Scanning Considerations .....	1-13
Scanning Bar Codes .....	1-13
Scanning Tips .....	1-14
LED Indications .....	1-14

Resetting the MC18 .....	1-15
Performing a Warm Boot .....	1-15
Performing a Cold Boot .....	1-15
Replacing the Bezel .....	1-16

## Chapter 2: Staging and Provisioning

Introduction .....	2-1
Staging .....	2-1
Bar Code Staging .....	2-2
On-Demand Staging .....	2-4
ActiveSync Connection Mode .....	2-4
Already existing IP Connection Mode .....	2-4
Well-known WLAN Connection Mode .....	2-4
RD Client Main Menu .....	2-6
Client Info .....	2-6
Log Menu .....	2-7
View Log .....	2-7
View Job Log .....	2-8
Set Log Level .....	2-8
Set Job Log Level .....	2-9
Package List .....	2-9
Provisioning .....	2-11
MSP Agent .....	2-11
MSP Agent Main Menu .....	2-11
Monitor Processing .....	2-12
Force Check-In .....	2-12
Package List .....	2-12
Client Info .....	2-13
Log Menu .....	2-13
View Log .....	2-14
View Job Log .....	2-14
Set Log Level .....	2-15
Set Job Log Level .....	2-15
Hide UI .....	2-16

## Chapter 3: Wireless Applications

Introduction .....	3-1
802.11d Overview .....	3-1
Configuring My Country for Use with WLAN on an MC18 .....	3-1
Enabled 802.11d Network .....	3-2
Disabled 802.11d Network .....	3-2
Create WCS Options Registry File .....	3-2
Update MC18 via 802.11d Enabled Staging Network .....	3-2
Connect to the Non-802.11d Network .....	3-3
Wireless Application on the MC18T/MC18U .....	3-3
Signal Strength Icon .....	3-4
Turning Off the Radio .....	3-5



**Chapter 4: ActiveSync**

ActiveSync .....	4-1
Installing ActiveSync .....	4-1
MC18 Setup .....	4-2
Setting Up an ActiveSync Connection on the Host Computer .....	4-2
Setting up a Partnership .....	4-3

**Chapter 5: Using the Windows CE Desktop**

Introduction .....	5-1
ActiveSync .....	5-1
Remote Control Software .....	5-1
Connection to Host Computer .....	5-1
Programming Cable Removal .....	5-5
App Launcher Window .....	5-6
Windows CE 7.0 Desktop .....	5-7
Status Icons .....	5-7
Battery Unknown Icon .....	5-8
Start Button .....	5-9
Programs Menu .....	5-9
Desktop Display Button .....	5-10
Entering Information Using the Keyboard Input Panel .....	5-10
Task Bar and Start Menu Properties .....	5-10
Properties .....	5-10
Advanced Tab .....	5-11
Screen Calibration .....	5-11
Waking the MC18 .....	5-12

**Chapter 6: Special Considerations**

Introduction .....	6-1
Fonts .....	6-1
Asian Font Installation .....	6-2
Software Development Considerations .....	6-2
Tips for Improving Battery Charge Time .....	6-2
Cradle-Backlight Feature .....	6-3
Tips for Improving Battery Life .....	6-3
Changing the Power Settings .....	6-4
Changing the Display Backlight Settings .....	6-4
MC18U Support .....	6-5

**Chapter 7: Pocket Browser**

Introduction .....	7-1
Sample Application .....	7-1

**Chapter 8: Cradle Installation**

Introduction .....	8-1
Installation of the Cradle .....	8-1
Removing the Front Cover .....	8-1

Mounting the Cradle .....	8-2
Wiring .....	8-4
Assembly .....	8-5
Cradle Location Bar Code .....	8-6
System Cabling .....	8-7
Mounting the Power Supply Housing .....	8-9

## Chapter 9: Application Deployment

Software Installation on Development PC .....	9-1
Device Configuration Package .....	9-1
Platform SDK .....	9-2
Enterprise Mobility Developer Kits .....	9-2
Installing Other Development Software .....	9-2
Deployment .....	9-3
ActiveSync .....	9-3
IPL .....	9-4
Creating Hex Images .....	9-5
Starting Terminal Configuration Manager .....	9-5
Defining Script Properties .....	9-7
Creating the Script for the Hex Image .....	9-8
Opening a New or Existing Script .....	9-8
Updating TCM 1.X Scripts .....	9-8
Copying Components to the Script .....	9-8
Saving the Script .....	9-9
Building the Image .....	9-9
Sending the Hex Image Using IPL .....	9-10
TCM Error Messages .....	9-14
IPL Error Detection .....	9-16
Creating a Splash Screen .....	9-18
Splash Screen Format .....	9-18
OS Update .....	9-19
MC18 .....	9-19
MC18 .....	9-21
Flash Storage .....	9-23
FFS Partitions .....	9-23
Working with FFS Partitions .....	9-23
RegMerge.dll .....	9-23
CopyFiles .....	9-24
Non-FFS Partitions .....	9-24
Downloading Partitions to the MC18 .....	9-25

## Chapter 10: Maintenance and Troubleshooting

Introduction .....	10-1
Maintaining the MC18 .....	10-1
Battery Safety Guidelines .....	10-1
Battery Management .....	10-2
Clearing the Battery .....	10-2
Long Term Storage .....	10-3
Cleaning .....	10-4

Materials Required .....	10-4
Cleaning the MC18 .....	10-4
Housing .....	10-4
Display .....	10-4
Scanner Exit Window .....	10-4
Connector .....	10-4
Cleaning Cradle Connectors .....	10-5
Cleaning Frequency .....	10-5
Troubleshooting .....	10-6
MC18 .....	10-6
Cradle .....	10-9

## Appendix A: Technical Specifications

Technical Specifications .....	A-1
Cradle .....	A-3
Cable Specifications .....	A-6
Power Supply Cable, Y-type .....	A-6
Cradle Interconnection Cable .....	A-6

## Appendix B: AirBEAM Smart Client

Introduction .....	B-1
AirBEAM Package Builder .....	B-1
AirBEAM Smart Client .....	B-2
AirBEAM License .....	B-2
Configuring the AirBEAM Smart Client .....	B-2
Packages(1) Tab .....	B-2
Packages(2) Tab .....	B-3
Server Tab .....	B-4
Misc(1) Tab .....	B-4
Misc(2) Tab .....	B-5
Misc(3) Tab .....	B-6
Misc(4) Tab .....	B-7
Synchronizing with the Server .....	B-8
Manual Synchronization .....	B-9
Automatic Synchronization .....	B-9
AirBEAM Staging .....	B-9

## Appendix C: App Launcher Configuration

Configuration .....	C-1
---------------------	-----

## Glossary

## Index



# ABOUT THIS GUIDE

---

## Introduction

This guide provides information about setting up and configuring MC18 mobile computers and installing its accessories.



**NOTE** Some screens or windows shown in this guide may differ from the actual screens shown on the MC18.

## Documentation Set

The documentation set for the MC18 is divided into guides that provide information for specific user needs.

MC18 documentation includes:

- **MC18 Quick Reference Guide** - describes basic set up and operation of the MC18 and it's cradles. The guide also includes regulatory and safety information.
- **MC18 Product Reference Guide** (this guide) - describes how to set up, operate and program the MC18 and it's accessories.
- **Microsoft Applications for Windows Mobile and WinCE 7.0 User Guide** - describes how to use Microsoft developed applications.
- **Application Guide for Symbol Technologies Enterprise Mobility Devices** - describes how to use Symbol Technologies developed applications.
- **EMDK Help File** - provides API information for writing applications.

## Software Versions

This guide covers various software configurations and references are made to operating system or software versions.

## OEM Software

Use this procedure to determine the OEM software version on the MC18:

1. Connect the MC18 to a host computer (see [Connecting the MC18 to a Host Computer on page 4-2](#)).
2. Click **Start > Settings > Control Panel > System Info** icon.
3. Make sure that the OEM software version on the MC18 is 99.42.00 or greater:

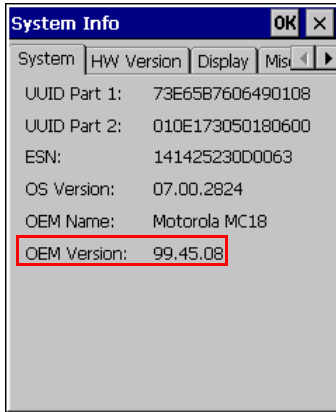

## Fusion Software

To determine the Fusion software version on MC18 with OEM version X\_2.01.0.0.062R or greater:

**Start > Programs > Fusion > Wireless status > Versions.**

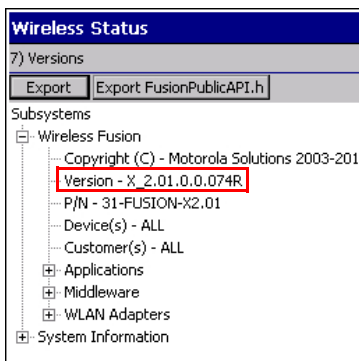

## Chapter Descriptions

Topics covered in this guide are as follows:

- [Chapter 1, Getting Started](#), describes the features and basic operation of the MC18, lists the accessories for the MC18 and explains how to install and charge the batteries and start the MC18 for the first time.
- [Chapter 2, Staging and Provisioning](#), provides information for staging and provisioning the MC18 using Mobility Software Platform (MSP).
- [Chapter 3, Wireless Applications](#), provides instructions for configuring the wireless adapter.
- [Chapter 4, Sync with Host Computer](#), provides instructions on installing a sync application and setting up a partnership between the MC18 and a host computer.
- [Chapter 5, Using the Windows CE Desktop](#), provides instructions for connecting the MC18 to a host computer and using the OS desktop of the MC18.

- [Chapter 6, \*Special Considerations\*](#), provides information to consider when using and developing applications for the MC18.
- [Chapter 7, \*Pocket Browser\*](#), provides information on Sample Pocket Browser (mobile application development tool) provided with the MC18.
- [Chapter 8, \*Cradle Installation\*](#), provides installation instructions for the MC18 cradles and other accessories.
- [Chapter 9, \*Application Deployment\*](#), provides instructions for installing the Device Configuration Package (DCP) for MC18 and the EMDK for C on the host computer and downloading software and files to the MC18.
- [Chapter 10, \*Maintenance and Troubleshooting\*](#), includes instructions on cleaning and storing the MC18, and provides troubleshooting solutions for potential problems during MC18 operation.
- [Appendix A, \*Technical Specifications\*](#), includes a table listing the technical specifications for the MC18 and accessories.
- [Appendix B, \*App Launcher Configuration\*](#), provides information for configuring the App Launcher application.

---

## Notational Conventions

The following conventions are used in this document:

- “Mobile computer” refers to the Symbol Technologies MC18 of mobile computers.
- *Italics* are used to highlight the following:
  - Chapters and sections in this guide
  - Related documents
- **Bold** text is used to highlight the following:
  - Dialog box, window and screen names
  - Drop-down list and list box names
  - Check box and radio button names
  - Icons on a screen
  - Key names on a keypad
  - Button names on a screen.
- Bullets (•) indicate:
  - Action items
  - Lists of alternatives
  - Lists of required steps that are not necessarily sequential.

Sequential lists (e.g., those that describe step-by-step procedures) appear as numbered lists.



**NOTE** This symbol indicates something of special interest or importance to the reader. Failure to read the note will not result in physical harm to the reader, equipment or data.



**CAUTION** This symbol indicates that if this information is ignored, the possibility of data or material damage may occur.



**WARNING!** This symbol indicates that if this information is ignored the possibility that serious personal injury may occur.

---

## Related Documents and Software

The following documents provide more information about the MC18 mobile computers.

- *MC18 Quick Reference Guide*, p/n MN000835A01
- *Microsoft Applications for Windows Mobile and CE 7.0 User Guide*, p/n 72E-78456-xx
- *Enterprise Mobility Developer Kits*, available at:
- Device Configuration Package (DCP for MC18 v99.45.00xx) and Platform SDK for MC18 with Windows CE 7.0, available at: <http://www.motorolasolutions.com/support>
- Latest ActiveSync (Windows xp) or Windows Mobile Device Center (Windows 7) software, available at: <http://www.microsoft.com>.

For the latest version of this guide and all guides, go to: <http://www.motorolasolutions.com/support>

---

## Service Information

If you have a problem with your equipment, contact Symbol Technologies Global Customer Support for your region. Contact information is available at: <http://www.motorolasolutions.com/support>.

When contacting Symbol Technologies Global Customer Support, please have the following information available:

- Serial number of the unit
- Model number or product name
- Software type and version number.

Symbol Technologies responds to calls by E-mail, or telephone within the time limits set forth in support agreements.

If your problem cannot be solved by Symbol Technologies Global Customer Support, you may need to return your equipment for servicing and will be given specific directions. Symbol Technologies is not responsible for any damages incurred during shipment if the approved shipping container is not used. Shipping the units improperly can possibly void the warranty.

If you purchased your Symbol Technologies business product from a Symbol Technologies business partner, contact that business partner for support.



# CHAPTER 1 GETTING STARTED

---

## Introduction

This chapter describes the features of the MC18 and explains how to install and charge the battery, how to capture data using the integrated Imager and how to reset the MC18.

## Unpacking

Carefully remove all protective material from the MC18 and save the shipping container for later storage and shipping.

Verify that box contains all the equipment listed below:

- MC18
- Lithium-ion battery
- Quick Reference Guide

Inspect the equipment for damage. If you are missing any equipment or if you find any damaged equipment, contact Symbol Technologies Support immediately. See [Service Information on page xiv](#) for contact information.

## Removing the Screen Protection Film

A screen protection film is applied to the MC18 screen to protect the screen during shipping. To remove the screen protector, carefully lift the thin film off the display.

## Features

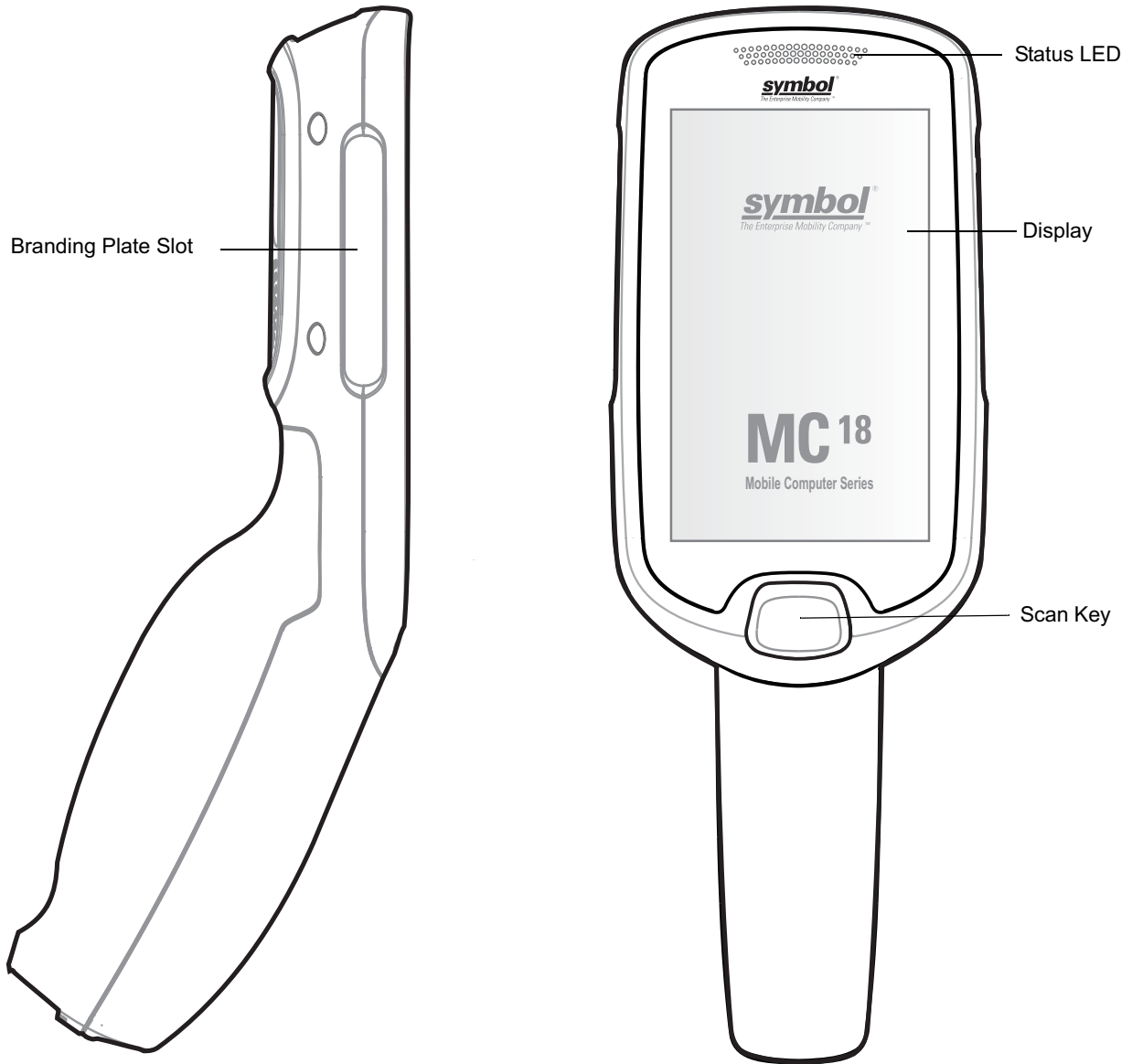

Figure 1-1 Front View

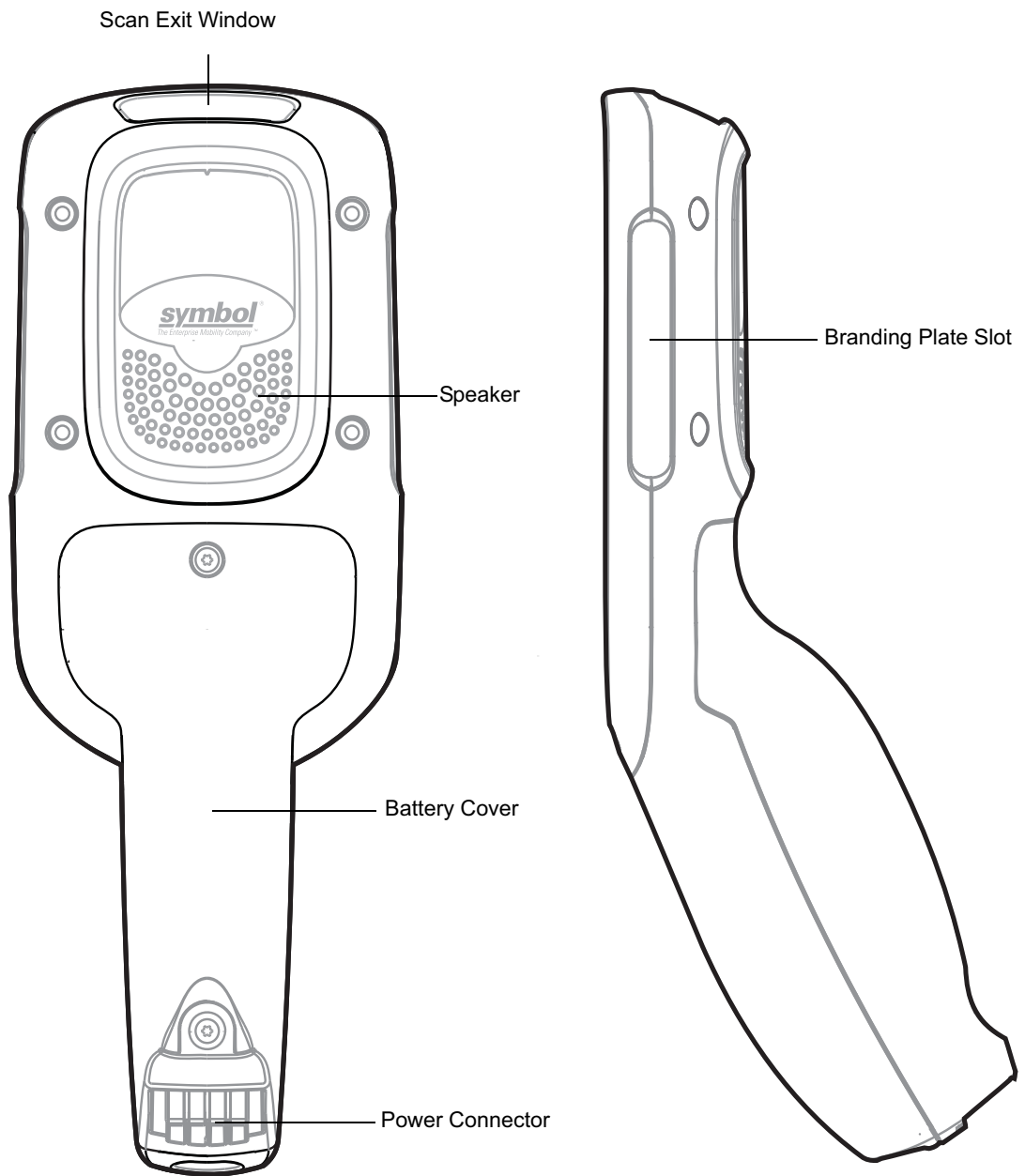

Figure 1-2 Back View

## Accessories

**Table 1-1** *Accessories*

Accessory	Part Number	Description
MC18 Lithium Ion Battery	BTRY-MC18-27MAG-01	MC18 Lithium Ion Battery.
	BTRY-MC18-27MAG-10	MC18 Lithium Ion Battery (QTY-10).
High Density (HD) Three Slot Cradle (Locking).	CRD-MC18-3SLCKH-01	The cradle is used for docking up to three MC18 units in HD installation configuration. The cradle slots are equipped a mechanism that locks the MC18 units inside the slots. Three Slot Cradle Requires PWRS-14000-241R, DC line cord and Country Specific AC line cord sold separately.
High Density (HD) Three Slot Cradle (Non-Locking)	CRD-MC18-3SLOTH-01	The cradle is used for docking up to three MC18 units in HD installation configuration. Requires PWRS-14000-241R, DC line cord and country specific AC line cord (sold separately).
Super High Density (SHD) Three Slot Cradle (Locking)	CRD-MC18-3SLCKS-01	The cradle is used for docking up to three MC18 units in SHD installation configuration. The cradle slots are equipped a mechanism that locks the MC18 units inside the slots. Requires PWRS-14000-241R, DC line cord and country specific AC line cord sold separately.
Single Slot Cradle	CRD-MC18-1SLOT-01	The cradle is used for docking a single MC18. Requires power supply unit (PWRS-14000-241R), DC line cord and country specific AC line cord sold separately.
Release Key.	KT-MC18-CKEY-20	Tool used to mechanically unlock the MC18 from a Three Slot Cradle.
MC18 Terminal Reboot Tool	KT-MC18-REBOOT-05	Tool used for cold reboot of the MC18 (QTY-5).
Three Slot Cradle Front Panel Removing Tool	KT-MC18-CTOOL-01	Tool used for removing the cradle cover.
Deployment Kit	KT-MC18-CSTKIT-01	Includes: <ul style="list-style-type: none"> <li>• 20-pack of Release Key (KT-MC18-CKEY-20)</li> <li>• 5-pack of Terminal Reboot Tool (KT-MC18-REBOOT-05)</li> <li>• One Three Slot Cradle Front Panel Removing Tool (KT-MC18-CTOOL-01)</li> </ul>
Single Slot Cradle Release Key	PSS-3KY01-00R	Key used to mechanically unlock the MC18 from a single slot cradle (QTY-20).

**Table 1-1** *Accessories*

<b>Accessory</b>	<b>Part Number</b>	<b>Description</b>
Cart Holder Mounting Kit	PSS-3SH01-00R	Kit for mounting the MC18 on a shopping cart.
Programming Cable	CBL-MC18-USB1-01	USB communication cable for connecting the MC18 to a host computer.
Interconnection Cable	25-66431-01R	An extension cable (12.6 Inch / 32 centimeter) for connection three slot cradle to DC "Y" charging cable that is connected to power supply unit (PWRS-14000-241R).
Power Extension Cable	CBL-MC18-EXINT1-01	Cable (12.6 Inch / 32 centimeter) for daisy chain connection of two Three Slot Cradles to one power supply unit (PWRS-14000-241R).
DC Charging Cable	25-66420-01R	DC charging cable (19.5 Inch / 49.5 centimeter) used to connect a power supply unit (PWRS-14000-241R) to one single-slot cradle.
DC "Y" Charging Cable Long	25-67592-01R	DC "Y" charging cable (39.7 Inch / 1 meter). Connects a power supply unit (PWRS-14000-241R) to two separate Three Slot Cradles.
DC "Y" Charging Cable Short	25-66210-01R	DC "Y" charging cable (19.5 Inch / 1 meter). Connects a power supply unit (PWRS-14000-241R) to two separate Three Slot Cradles.
Power Supply Unit	PWRS-14000-241R	100-240VAC, 12VDC, 9A. Requires country specific AC line cord and DC cable - all sold separately.
AC Line Cord	23844-00-00R	AC Line Cord, 7.5 feet long, grounded, three wire for power supplies. Associated Country: United States
AC Line Cord	50-16000-221R	AC Line Cord, 1.8 meter, meter grounded, three wire, USA NEMA 5-15P. Associated Country: United States
AC Line Cord	50-16000-671R	AC Line Cord, 1.8 meter, grounded, three wire, CIE 23-16 plug. Associated Country: Italy.
AC Line Cord	50-16000-217R	AC Line Cord, 1.9 meter, grounded, three wire, AS 3112 plug. Associated Country: Australia, New Guinea
AC Line Cord	50-16000-218R	AC Line Cord, 1.8 meter, grounded, three wire, NEMA 1-15P plug. Associated Country: Japan.
AC Line Cord	50-16000-219R	AC Line Cord, 1.8 meter, grounded three wire, BS1363 plug. Associated countries: Hong Kong, Iraq, Malaysia, Singapore, United Kingdom.

**Table 1-1** *Accessories*

<b>Accessory</b>	<b>Part Number</b>	<b>Description</b>
AC Line Cord	50-16000-220R	AC Line Cord, 1.8 meter, grounded three wire CEE 7/7plug. Associated countries: Europe, Abu Dhabi, Bolivia, Dubai, Egypt, Iran, Russia, Vietnam.
AC Line Cord	50-16000-257R	AC Line Cord, 1.8 meter, grounded three wire, IEC 60320 C13 plug. Associated Country: China.
AC Line Cord	50-16000-669R	1.9 meter grounded three wire, BS 546 Plug. Associated country: India.
AC Line Cord	50-16000-672R	1.9 meter grounded three wire, S132 Plug. Associated country: Israel.
AC Line Cord	50-16000-678R	36 Inch grounded three wire. Associated country: United States

## Status LED

The Status LED indicates the condition of the MC18. [Table 1-2](#) describes the Status LED indications.



**Figure 1-3** MC18 Status LED

**Table 1-2** Status LED Indications

LED State	Indication
Off	Normal operation or MC18 is turned off.
Single Green blink	Successful Decode.

## Scan Key

The scan key operates the imager camera when a scanning application is active. When turned off, pressing the scan key powers on the MC18.

Note that Scan Key functions can be changed by an application so the MC18's Scan Key may not function exactly as described. Refer to the *EMDK Help* file for detailed information for programming the Scan Key.

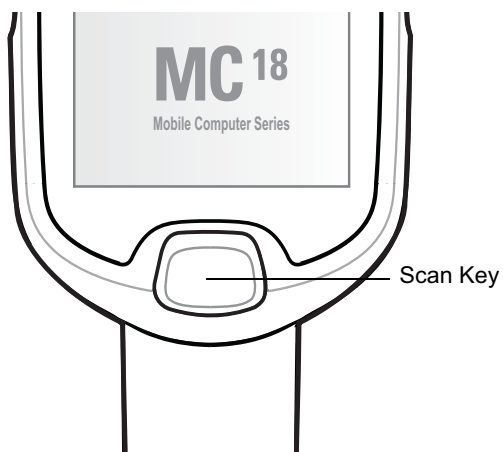

**Figure 1-4** Scan Key

---

## Getting Started

To start using the MC18 for the first time:

- Install the battery
- Charge the battery.

---

## Installing the Battery

To start using the MC18, the battery must be installed and charged.

To install the battery:

1. Using Torx T8 drive, remove two screws that secure the battery cover.
2. Lift the battery cover from the handle.
3. Guide and press the battery cable connector into the female connector inside the battery compartment. The connector is designed to only fit one way.
4. Place the battery inside the battery compartment.
5. Place the battery cover onto the handle.
6. Secure the battery cover with the two Torx screws using a T8 Torx drive. Torque the screws to 3.6 Kgf-cm (3.1 in-lb).

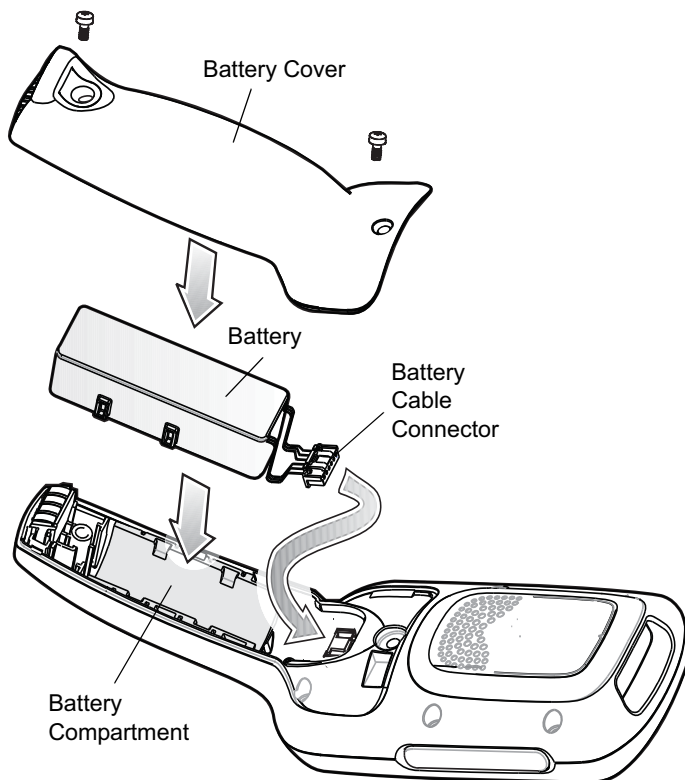

**Figure 1-5** *Installing the Battery*



## Removing the Battery

To remove the battery:

1. Use T8 Torx drive to remove the two screws that secure the battery cover.
2. Lift the battery cover from the handle.
3. Inside the battery compartment, press down the plastic tab of the Battery cable connector and slide it out of the female connector.
4. Remove the battery from the battery compartment.

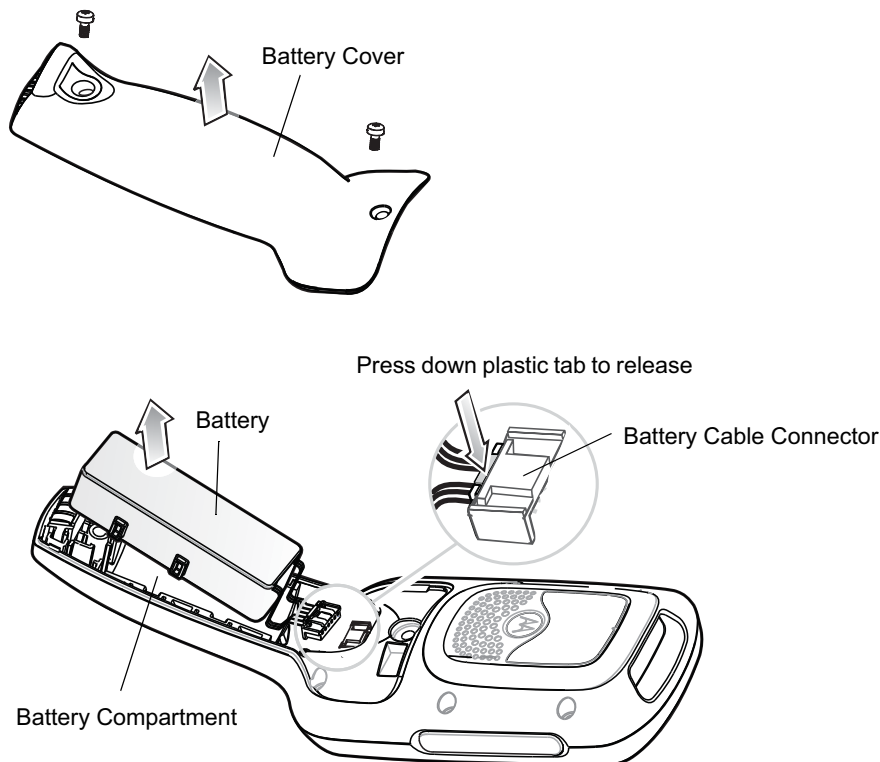

**Figure 1-6** Removing the Battery

## Charging the Battery



**CAUTION** Ensure that you follow the guidelines for battery safety described in [Battery Safety Guidelines on page 10-1](#).



**NOTE** Battery life is based upon the following; MC18 usage, WLAN radio is set to maximum power mode, WLAN is associated with an Access Point and display backlight set to 25% brightness.

Before using the MC18 for the first time, charge the battery. The battery fully charges in approximately four hours.

Use this procedure to charge the battery:

1. Ensure the cradle is connected to the appropriate power source. See [Chapter 8, Cradle Installation](#) for more information.

2. Dock the MC18 in a cradle. The MC18 starts to charge automatically and  is shown on the taskbar.

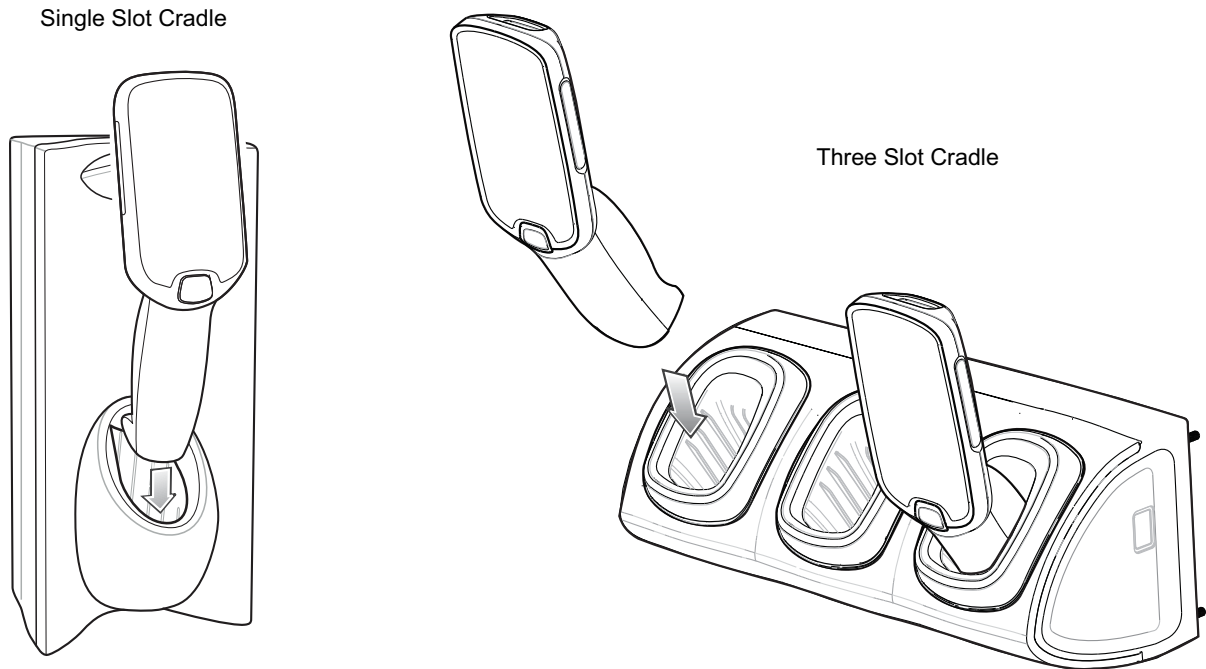

**Figure 1-7** Docking MC18 into Cradle

---

## Starting the MC18

The MC18 starts automatically as soon as power is applied; either with a charged battery installed or when inserted into the cradle.

If charged battery is installed and the MC18 is turned off, hold the scan key pressed for five seconds to turn on.

If the MC18 does not power on, perform a cold boot (see [Performing a Cold Boot on page 1-17](#)).

When the MC18 is powered on for the first time, it initializes its system. The splash screen appears for a short period of time.



**Figure 1-8** *Splash Screen*

On the MC18, the splash screen is followed by the **App Launcher** window.

✓ **NOTE** App Launcher window may vary depending upon the MC18 operating system version.



**Figure 1-9** *App Launcher Window*

## Data Capturing

The MC18 uses an imager to allow collection of data by scanning bar codes.

The scanner has the following features:

- Reads a variety of bar code symbologies, including the most popular linear, postal, and 2-D code types (see [Appendix , Technical Specifications](#)).
- Contains advanced intuitive aiming light for easy point-and-shoot operation.

## Scanning Considerations

Typically, scanning is a simple matter of aim, scan/decode and a few quick trial efforts master it. However, two important considerations can be used to optimize any scanning performance:

- Range

Any scanning device decodes well over a particular working range — minimum and maximum distances from the bar code. This range varies according to bar code density and scanning device optics.

Scanning within range brings quick and constant decodes; scanning too close or too far away prevents decodes. Move the MC18 closer and further away to find the right working range for the bar codes being scanned. However, the situation is complicated by the availability of various integrated scanning modules. The best way to specify the appropriate working range per bar code density is through a chart called a decode zone for each scan module. A decode zone simply plots working range as a function of minimum element widths of bar code symbols.

- Angle

Don't scan at too sharp an angle; the scanner needs to collect scattered reflections from the scan to make a successful decode. Practice quickly shows what tolerances to work within.

✓ **NOTE** Contact the Symbol Technologies Global Customer Support if chronic scanning difficulties develop. Decoding of properly printed bar codes should be quick and effortless.

## Scanning Bar Codes

1. Ensure that a scan enabled application (for example: Scanning Sample) is loaded and enabled on the MC18.
2. From the App Launcher screen, touch **Demo Applications > Scanning Sample**.
3. Aim the scan exit window at the bar code.
4. Press the scan key.  
Ensure the red aiming dot is at the center of the bar code. The LED changes from red to green and audible beep sounds if bar code was decoded successfully.



**Figure 1-10** Imager Aiming Pattern

5. Release the **Scan** key. The bar code data is displayed on the screen.

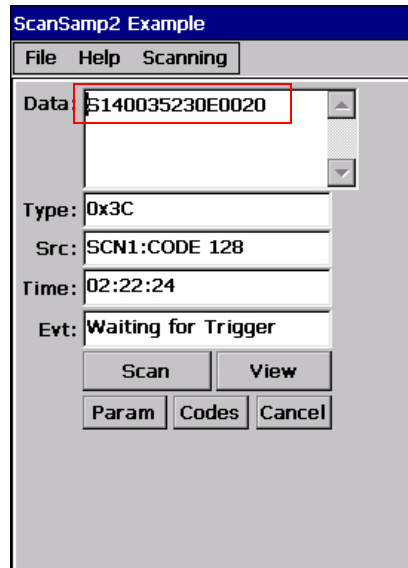

**Figure 1-11** Scanning Sample Application Screen

### Scanning Tips

Optimal scanning distance varies with bar code density and scanner optics.

- Hold the scanner farther away for larger symbols.
- Move the scanner closer for symbols with bars that are close together.



**NOTE** Scanning procedures depend on the application and MC18 configuration. An application may use different scanning procedures from the one listed above.

---

## DataWedge

DataWedge is an application that reads data from a scanning source, processes the data and sends the data to an application as if the user is entering it on a keyboard. By default, DataWedge is disabled. To use DataWedge Enable DataWedge.

### Enable DataWedge

Use this procedure to enable DataWedge:

1. Select **Start > Settings > Control Panel > DataWedge** icon.
2. Select **Basic Configuration**.
3. Select **1. Scanner input**.
4. Select **Low cost Imager**:
5. Select **1. Enabled**.
6. Click **0. Back**.
7. Click **0. Back**.

8. Click **0. Back**.
9. Click **0. Exit**.

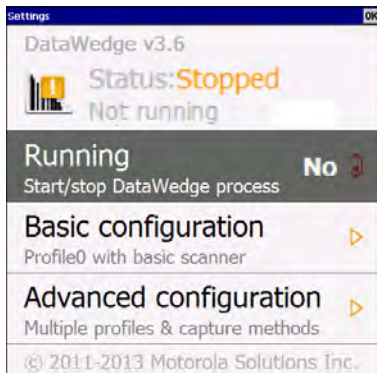

**Figure 1-12** *DataWedge Stopped*

10. Select **Running** to start the DataWedge process. The DataWedge Status changes to **Ready**.

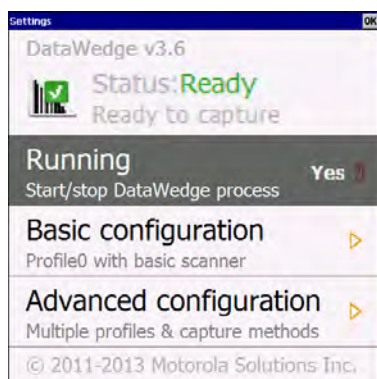

**Figure 1-13** *DataWedge Running*

11. Click **OK** to exit.

## Disable DataWedge

Use this procedure to disable DataWedge:

1. Select **Start > Settings > Control Panel > DataWedge** icon.
2. Select the **Running** option to end the DataWedge process. The **DataWedge Status** changes to **Stopped**.
3. Select **OK**.

## Using DataWedge to Read bar Codes

To read bar codes with DataWedge:

1. Enable DataWedge.
2. Open an application and select a text box or field for entering the bar code data.
3. Use one of the optional scanners and capture the bar code data. The data appears in the text box.

## Manual Release of MC18 from Cradles

The MC18 cradles contain a locking mechanism that locks the MC18 inside the cradle when docked. The MC18 releases from the cradle when a software command is received from the system. If the MC18 fails to un-lock during normal operation, use a release key to un-lock the MC18.

### Manual Release of MC18 from the Single-Slot Cradle

- ✓ **NOTE** The MC18 also can be released by software command using the PocketBrowser application (see [Sample Application on page 7-1](#)).

To release a locked MC18 from a single slot cradle:

1. Insert the release key into the slot located at the bottom side of the cradle.
2. While pressing the release key all the way into the slot, remove the MC18 from the cradle

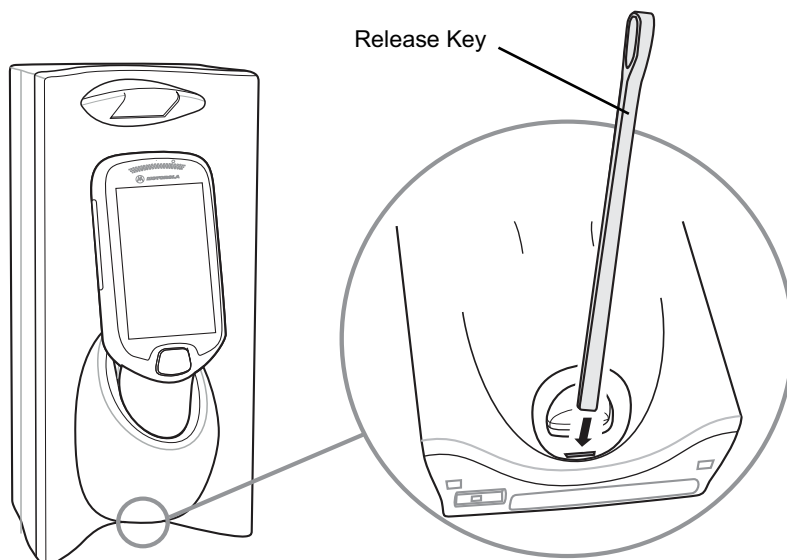

**Figure 1-14** Manual Release of MC18 from a Single Slot Cradle

### Three Slot Cradles

- ✓ **NOTE** The cradle includes models that do not have locking mechanism. To identify the model of cradle, refer to [Table 1-1 on page 1-4](#).
- ✓ **NOTE** The MC18 also can be released by software command using the Cradle Utility application (see [Setting and Controlling the Cradle on page 6-9](#)).

To release a locked MC18 from a three slot cradle:

1. Insert the release key straight into the slot, to a point where the bend stops.
2. Hold the release key pressed inside the slot and remove the MC18 from the slot.

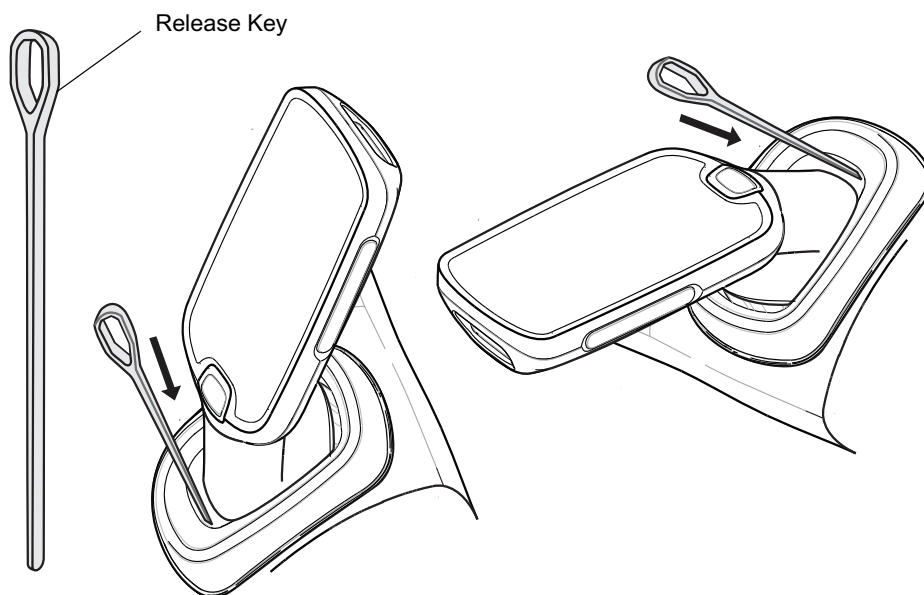

**Figure 1-15** Manual Release of MC18 from a Three Slot Cradle

## Resetting the MC18

There are two types of resets, warm boot and cold boot. A warm boot restarts the MC18 by closing all running programs.

A cold boot also restarts the MC18, but erases all stored records and entries in RAM. In addition it returns formats, preferences and other settings to the factory default settings.

Perform a warm boot first. This restarts the wearable terminal and saves all stored records and entries. If the wearable terminal still does not respond, perform a cold boot.

### Performing a Warm Boot

Use this procedure to perform a warm boot:

1. From the **Start** menu, click **Programs** to launch the **Programs** menu.
2. Click **Warm Boot**.

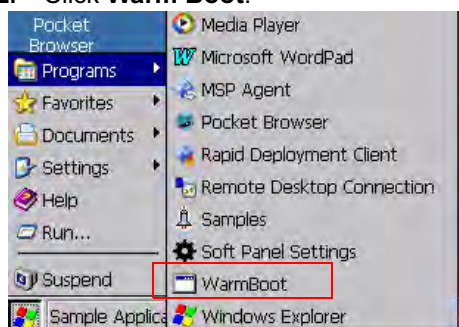

**Figure 1-16** Performing a Warm Boot



## Performing a Cold Boot

A cold boot restarts the MC18 and erases all user stored records and entries that are not saved in flash memory (Application and Platform folders). *Never perform a cold boot unless a warm boot does not solve the problem.*

✓ **NOTE** Any data previously synchronized with a computer can be restored during the next ActiveSync operation.

### Performing Cold Boot when the MC18 is Docked Inside the Cradle

Use this procedure to perform a cold boot when the MC18 is docked inside the cradle:

1. Press and hold the scan key for 10 seconds until the display powers off.
2. Release the scan key when the MC18 re-boots.

### Performing Cold Boot when MC18 is Out of the Cradle

Use this procedure to perform a cold boot when the MC18 is out of the cradle:

1. Insert the terminal reboot tool into the MC18 power connector and then press and hold the scan key for 10 seconds until the display powers off - the MC18 reboots.
2. Release the scan key and remove the terminal reboot tool from the MC18.

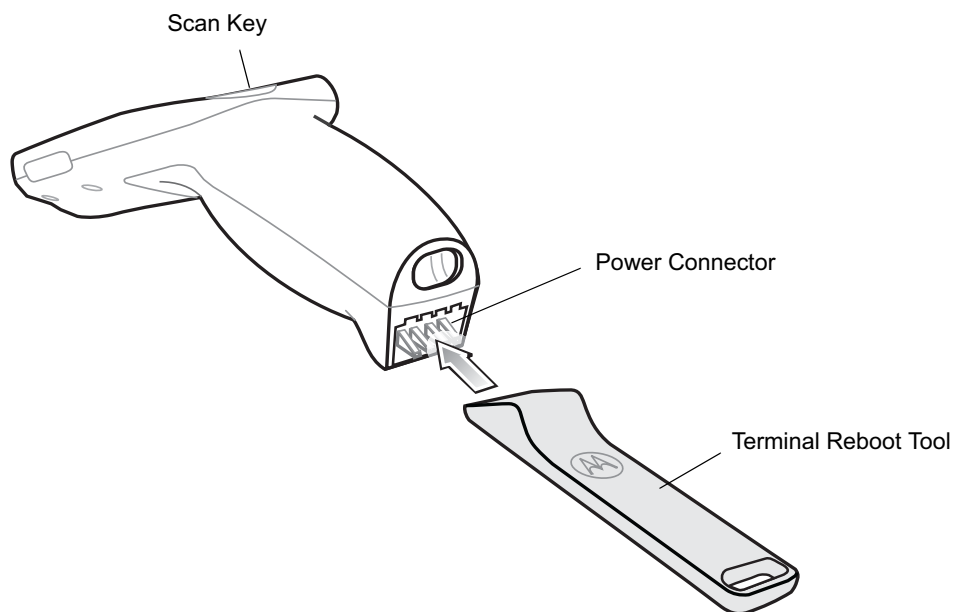

**Figure 1-17** Terminal Reboot Tool



# CHAPTER 2 STAGING AND PROVISIONING

---

## Introduction

This chapter describes how to stage and provision the MC18 mobile computers using Mobility Services Platform (MSP) 3.X.

---

## Staging

Staging is the process of setting up the MC18 to download packages for provisioning. The MC18 uses the Rapid Deployment (RD) Client for staging.

The RD Client enables simple and rapid provisioning of new (out of the box) mobile computers and simplifies the out-of-box provisioning by scanning bar codes or connecting to a profile server. The RD Client acts as a frontend for wireless radio configuration and AirBEAM Smart components, automating the manual configurations that would normally be required to use these tools.

- ✓ **NOTE** The MSP 3.0 Rapid Deployment Client enables staging by scanning staging profiles encoded into staging bar code sheets. It also enables staging to be performed without scanning bar codes through the use of On-Demand Staging. When using On-Demand Staging, the RD Client pulls staging profiles directly from an On-Demand Profile Server over some form of pre-configured or automatically-configured IP connection.

For detailed information about the MSP 3.X, refer to the *Mobility Services Platform 3.X User's Guide*.

An MSP Administrator uses the MSP Console for the creation of an RD profile that contains all the wireless network and security information (for example, ESSID, WEP Keys, etc.) required to get a MC18 onto the wireless network. The profile also contains FTP server access information needed to connect to the provisioning MSP and the list of software packages to be provisioned to the MC18 from the provisioning MSP. The RD profile can then be encoded into an RD bar code sheet and printed from the MSP Console or loaded onto a profile server.

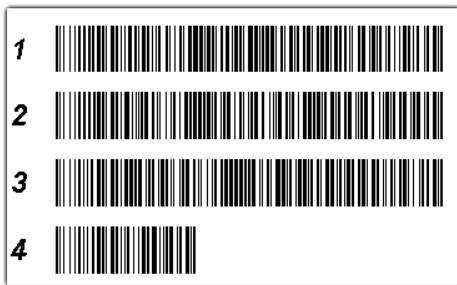

**Figure 2-1** RD Bar Code Printout Sample

## Bar Code Staging

When the MC18 boots for the first time (or after a cold boot) the **App Launcher** window appears. The **RD Client** option is highlighted.

✓ **NOTE** If the **App Launcher** screen does not display see your administrator.

Use this procedure to set bar code:

1. Obtain the appropriate RD bar code sheet from the MSP Administrator.
2. On the App Launcher screen, click **Rapid Deployment Client**.



3. **Result:** The **Scan Barcodes To Deploy** window displays.

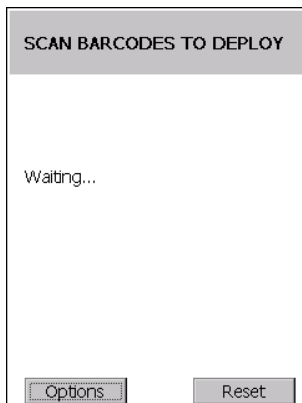
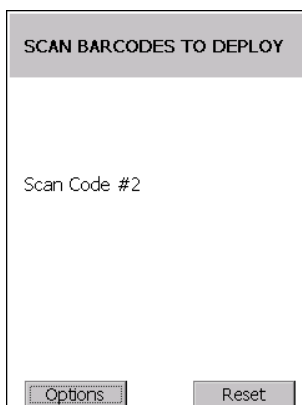

**Figure 2-2** *Scan Barcodes To Deploy window*

The **RD Client** waits for the first bar code scan.

4. Scan the first bar code. The window indicates which bar code to scan next.

✓ **NOTE** Multi-part linear bar codes (1-D bar codes) can require scanning several bar codes. Bar codes can be scanned in any order. The display indicate the bar code to scan.



**Figure 2-3** *Rapid Deployment Window - Scanning Bar Codes*

5. After all the bar codes are scanned successfully, the MC18 connects to the server and the **PROCESSING PROFILE** window displays while network settings are configured.

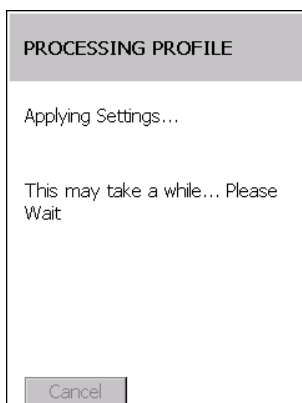

**Figure 2-4** *Rapid Deployment Window - Processing Profile*

- When staging is complete the **STAGING COMPLETE** window displays.

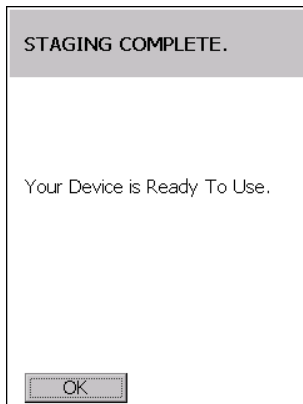

**Figure 2-5** *Staging Complete Window*

- Use **Options > Exit** button in RD client application to exit.

## On-Demand Staging

The MSP 3.0 **RD Client** also enables staging without having to scan bar codes through the use of On-Demand Staging (Electronic Staging).

When using On-Demand Staging, the RD Client pulls staging profiles directly from an On-Demand Profile Server over some form of pre-configured or automatically-configured IP connection. The following types of IP connection modes are currently supported for Electronic Staging:

### ActiveSync Connection Mode

This mode uses the IP connection that is established when the MC18 is directly connected (via a USB cable, serial cable or cradle) to a host computer running ActiveSync. The most common scenario would be where the On-Demand Profile Server is running on the host computer to which the MC18 is connected via ActiveSync. It would, however, also work with the On-Demand Profile Server running on any other host computer that is on the same subnet as the host computer to which the MC18 is connected via ActiveSync.

### Already existing IP Connection Mode

This mode uses any IP connection that is already active on the MC18. This could be a direct Ethernet port (if available), or a WLAN connection that was configured and established before the **RD Client** was launched. It could also be any other form of IP connection that might be available on the MC18. The **RD Client** does not do anything to configure or establish such connections, but uses them if they exist. The On-Demand Profile Server must be running on a host computer that is on the same subnet that is accessible from the connection.

### Well-known WLAN Connection Mode

This mode works only on supported Symbol Technologies WLAN adapters. The **RD Client** attempts to configure and establish WLAN IP connections using pre-defined Symbol Technologies WLAN settings. If the **RD Client** is able to successfully configure and establish such a connection, and if an On-Demand Profile Server is running on a host computer that is on the same subnet that is accessible from the connection, then Electronic Staging proceeds using that connection.

Use this procedure to perform On-Demand Staging:

- In the **App Launcher** menu, launch the **RD Client**. The **Scan Barcodes To Deploy** window displays.

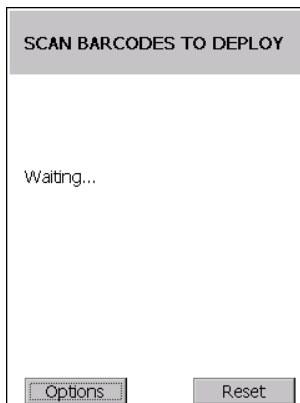

**Figure 2-6** *Waiting for Bar Codes*

2. Use **Options** > **Exit** button in RD client application to exit. The **Main Menu** window appears.

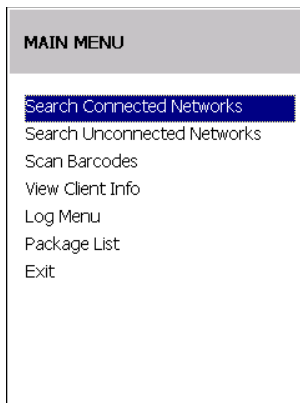

**Figure 2-7** *RD Client Main Menu*

3. Select **Search Connected Networks** or **Search Unconnected Networks**. The **SEARCHING NETWORKS** window appears.

Connected networks are networks that are already connected and can be checked to see if a Staging Server can be found. Unconnected Networks are the well-known WLAN connections that are automatically configured and established to see if a Staging Server can be found.

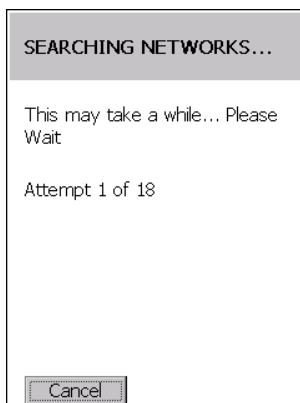

**Figure 2-8** *RD Client Searching for On-Demand Profile Server*

4. When complete, the **STAGING COMPLETE** window displays.

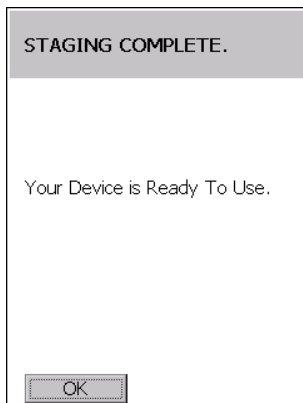

**Figure 2-9** *Staging Complete Window*

Use **Options > Exit** button in RD client application to exit.

## RD Client Main Menu

The RD Client **Main Menu** contains the following options:

- Search Connected Networks. See [On-Demand Staging on page 2-4](#) for detailed information.
- Search Unconnected Networks. See [On-Demand Staging on page 2-4](#) for detailed information.
- Scan Barcodes See [Bar Code Staging on page 2-2](#) for detailed information.
- View Client Info
- Log Menu
- Package List
- Exit - Closes the RD Client application.

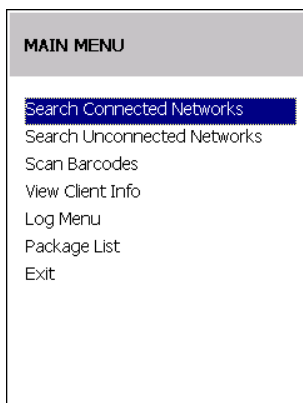

**Figure 2-10** *RD Client Main Menu*

## Client Info

Use the **Client Info** window to view the following information:

- RD Client version
- Product name



- Operating system type
- Plug-in type.

Select **View Client Info** option.

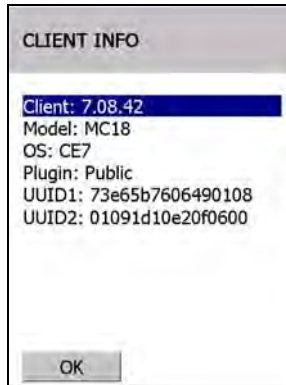

**Figure 2-11** Client Info Window

Press the **OK** to return to the **Main Menu**.

## Log Menu

The **Log Menu** contains the following options:

- View Log
- View Job Log
- Set Log Level
- Set Job Log Level.

Select **Log Menu** option.

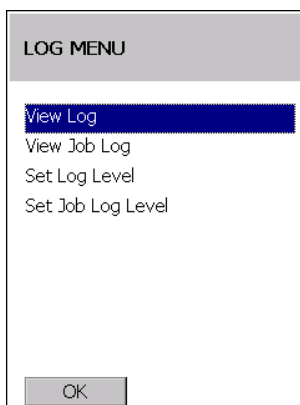

**Figure 2-12** Log Menu Window

Press **OK** to return to the **Main Menu**.

## View Log

Use the **View Log** option to display a list of events that have occurred.

Select **View Log** option.

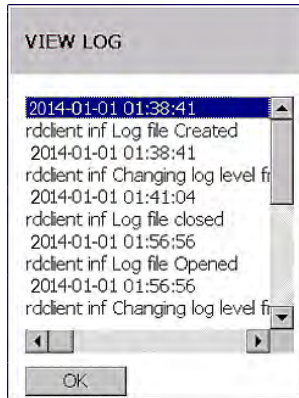

**Figure 2-13** *View Log Window*

Return to the **Log Menu**.

### **View Job Log**

Use the **View Job Log** option to display a list of jobs that have be processed.

Select **View Job Log** option.

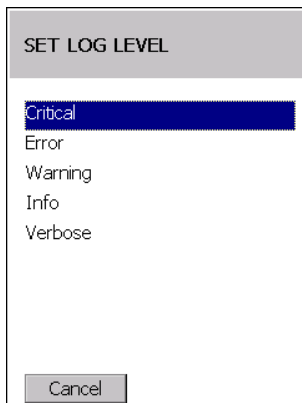

**Figure 2-14** *View Job Log Window*

Return to the **Log Menu**.

### **Set Log Level**

Use the **Set Log Level** option to set the level of the information that appears in the log.

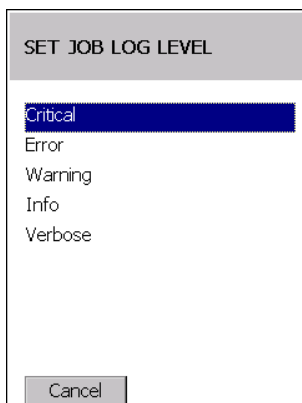

**Figure 2-15** *Set Log Level Window*

Select a level option.

### **Set Job Log Level**

Use the **Set Job Log Level** option to set the level of the information that appears in the Job log.



**Figure 2-16** *Set Job Log Level Window*

Select a level option.

### **Package List**

Use the **Package List** option to display the packages that have been installed on the MC18.

Select the **Package List** option.

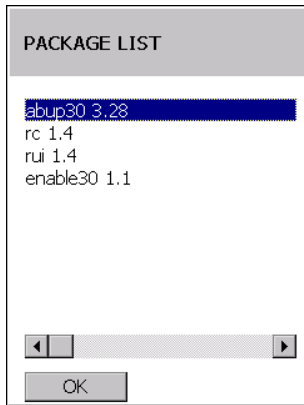

**Figure 2-17** *Package List Window*

Return to the **Main Menu**.

---

## Provisioning

Provisioning is the process of installing software packages onto the MC18 mobile computers.

### MSP Agent

✓ **NOTE** MSP Agent is also known as MSP 3.X Provisioning Client.

The Provisioning Client is responsible for implementing device-side provisioning activities as defined by a policy. A policy is evaluated on the MSP 3.X system and delivered to mobile computers as job documents via relay servers.

The MSP 3.X Provisioning Client is 100% backward compatible to prior versions of the AirBEAM Client. Existing AirBEAM Smart users can use the MSP 3.X Provisioning Client as a 100% backward compatible replacement for prior versions of AirBEAM Client, when used in classic AirBEAM mode with existing FTP servers.

Existing MSP 2.X users can use the new Provisioning Client as a 100% backward compatible replacement for previous versions of AirBEAM Client, when used in Level 2 Agent and Level 3 Agent modes with existing MSP 2.X Appliances.

For more detailed information on MSP Agent (Provisioning Client), refer to the MSP 3.X User's Guide (p/n 72E-100158-xx).

### MSP Agent Main Menu

The MSP Agent **Main Menu** contains the following options:

- Monitoring Processing
- Force Check-In
- Package List
- View Client info
- Log Menu
- Hide UI
- Exit - exits the MSP Agent application.

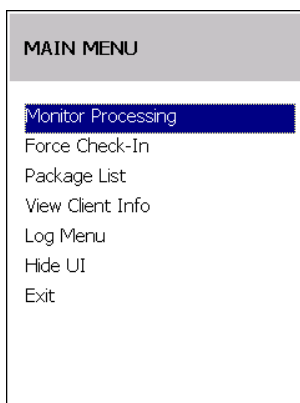
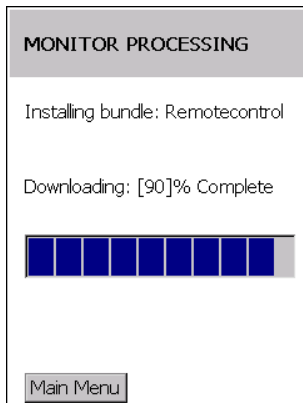

**Figure 2-18** MSP Agent Main Menu

### Monitor Processing

Use the **Monitor Processing** option to view the status of packages being processed.

Select the **Monitor Processing** option.



**Figure 2-19** *Monitor Processing Window*

Press **Main Menu** to return to the **Main Menu**.

### Force Check-In

Use the **Force Check-In** option to check instantly for pending package downloads instead of waiting for the next automatic check that the client performs.

Select the **Force Check-In** option.

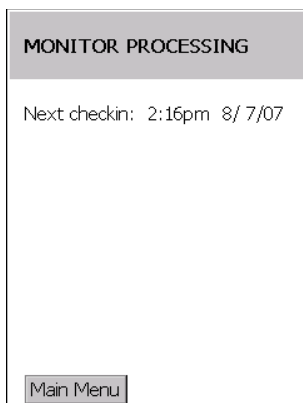

**Figure 2-20** *Force Check-in Window*

Press **Main Menu** to return to the **Main Menu**.

### Package List

Use the **Package List** option to display the packages that have been installed on the MC18.

Select the **Package List** option.

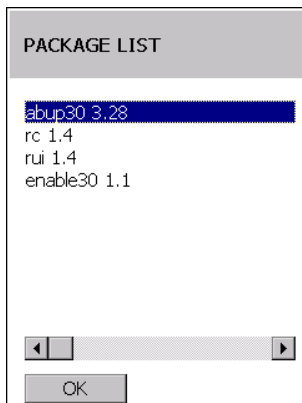

**Figure 2-21** *Package List Window*

Press **OK** to return to the **Main Menu**.

### Client Info

Use the **Client Info** window to view the following information:

- RD Client version
- Product name
- Operating system type
- Plug-in type.

Select **View Client Info** option.

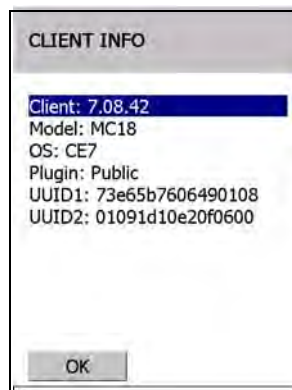

**Figure 2-22** *Client Info Window*

Press **OK** to return to the **Main Menu**.

### Log Menu

The **Log Menu** contains the following options:

- View Log
- View Job Log
- Set Log Level
- Set Job Log Level.

Select **Log Menu** option.

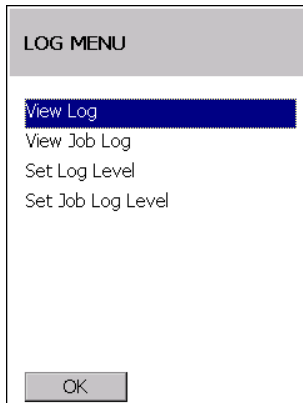

**Figure 2-23** *Log Menu Window*

Press **OK** to return to the **Main Menu**.

### **View Log**

Use the **View Log** option to display a list of events that have occurred.

Select **View Log** option.

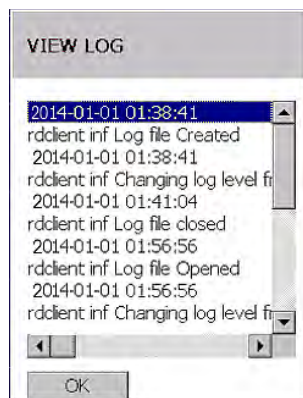

**Figure 2-24** *View Log Window*

Press **OK** to return to the **Log Menu**.

### **View Job Log**

Use the **View Job Log** option to display a list of jobs that have be processed.

Select **View Job Log** option.



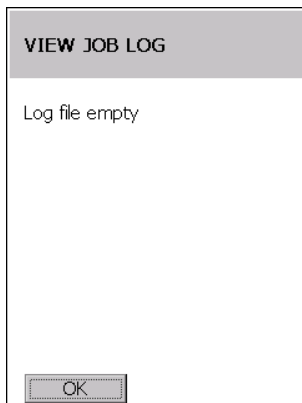
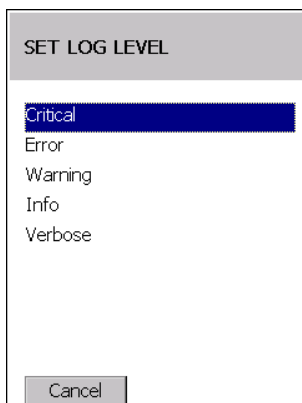

**Figure 2-25** *View Job Log Window*

Press **OK** to return to the **Log Menu**.

### **Set Log Level**

Use the **Set Log Level** option to set the level of the information that appears in the log.

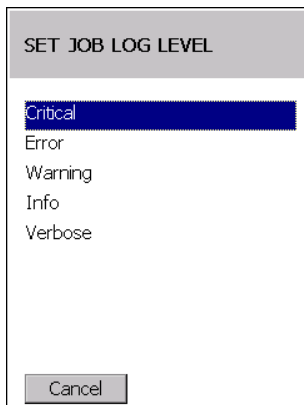

**Figure 2-26** *Set Log Level Window*

Select a level option.

### **Set Job Log Level**

Use the **Set Job Log Level** option to set the level of the information that appears in the Job log.



**Figure 2-27** *Set Job Log Level Window*

Select a level option.

### Hide UI

Use the **Hide UI** option to minimize the MSP Agent application. The MSP Agent application runs in the background while minimized.

To un-hide the application, select the **MSP Agent** icon in the task tray and select the **UnHide UI** menu item.

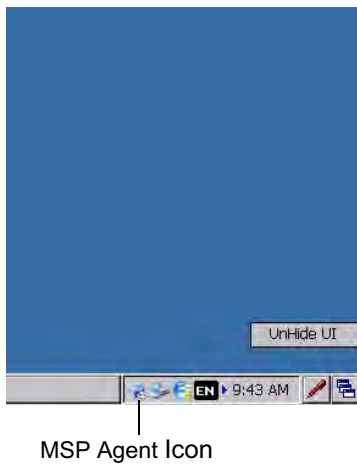

**Figure 2-28** *UnHide UI Selection*

# CHAPTER 3 WIRELESS APPLICATIONS

---

## Introduction

Wireless Local Area Networks (WLANs) allow the MC18 mobile computers to communicate wirelessly and send captured data to a host device in real time. The MC18 supports the 802.11a, 802.11b, 802.11g and 802.11n standards. Before using the MC18 on a WLAN, the facility must be set up with the required hardware to run the wireless LAN and the MC18 must be configured. Refer to the documentation provided with the access points (APs) for instructions on setting up the hardware.

To configure the radio in the MC18, use the Fusion APIs in the Enterprise Mobility Developer's Kit (EMDK). Refer to the *EMDK Help* file for detailed information.

The MC18 contain the Wireless Applications to allow configuration of the WLAN radio. On the MC18, use the touch screen to access the Wireless Application. MC18 requires the use of remote control software. See [Chapter 4, Sync with Host Computer](#) for more information.

---

## 802.11d Overview

IEEE 802.11d, is an amendment to the IEEE 802.11 specification that adds support for additional regulatory domains. This includes additional country information to beacons, probe requests, and probe responses. The country information simplifies the creation of 802.11 wireless access points (APs) and clients that meet the different regulations enforced in various parts of the world.

Fusion fully supports 802.11d for Regulatory purposes. By using 802.11d, the MC18 can easily connect to a wireless network and use only the valid channels for the country specified in the AP's beacons. By default, the MC18 software enables 802.11d mode to determine regulatory requirements.

---

## Configuring My Country for Use with WLAN on the MC18

Configuration can be done on:

- an enabled 802.11d network
- a disabled 802.11d network.

## Enabled 802.11d Network

There is no need to configure a country if 802.11d is used by the Access Point (AP). Verify that the wireless network infrastructure has 802.11d enabled.

Use this procedure to connect to a network with 802.11d enabled:

1. Use Mobility Services Platform (MSP) to generate bar codes that contain a Fusion wireless network profile for use with Rapid Deployment (RD). This profile should match the network that is being connected to (a properly configured ESSID).
2. On the MC18, use RD to scan the MSP Fusion Profile bar codes.
3. RD imports the Fusion Profile into the Fusion Database and attempts to connect to the network configured in the profile. Fusion uses the country code information provided in the AP's beacon (802.11d) to determine the regulatory requirements and connect to the network using a valid WLAN channel.

## Disabled 802.11d Network

If the network does not have 802.11d enabled, it is necessary to create:

A Fusion Options gpdexport file on another device, running Fusion X2.00 or above on a new staging network dedicated to the transition from 802.11d to using a specific country code.

This staging network needs to have 802.11d enabled. This staging network could be as simple as an AP connected to a host computer and multiple MC18s. A separate non-MC18 Fusion based device (MC67, MC92N0, VC70, etc.) is needed to create the Fusion Options gpdexport file.

### Create Fusion Options gpdexport File

To export the Fusion Options to a gpdexport file that contains the proper settings for the network, perform the following steps:

1. Obtain another device that has Fusion applications on it. This device should have Fusion X2.00 or later version on it.
2. On this device, tap the Wireless icon in the system tray and select Options from the menu. The Options window appears.
3. In the Options drop-down list, select Regulatory.
  - a. In the Settings drop-down list, select the country code to use.
  - b. Un-check the Enable 802.11d checkbox.
  - c. Tap Save.
4. In the Options drop-down list, select Import/Export.
  - a. Tap the Export Options button. The Export File Wizard window appears.
  - b. Select Fusion Options and Overwrite conflicting records checkboxes. Uncheck all other checkboxes and tap on Export to file button.
  - c. The Save As window appears.
  - d. Save the Fusion Options gpdexport file to the device (name the file as desired).
5. Tap X to close the Options window.
6. Using a Sync application, copy the Fusion Options gpdexport file to a host computer. This file will be downloaded to configure MC18 devices with the correct country and 802.11d mode.

### Update MC18 via 802.11d Enabled Staging Network

Use the staging network to configure all devices with the correct country code and 802.11d mode:

1. Configure RD to download packages from a FTP server that is accessible from the staging network. This may require MSP bar codes, etc.
2. The Out of Box magic profile for the MC18 devices automatically attempts to connect to a wireless network with an ESSID of "101". This should be the same ESSID of the staging network.
3. Place the Fusion Options gpdexport file (created using the alternate Fusion based device), on the staging network's FTP server.
4. The MC18 should download the Fusion Options gpdexport file from the staging network to and configure 802.11d mode and the country code.
5. The MC18 should perform a cold boot so that the new configuration takes effect.

### Connect to the Non-802.11d Network

Since the MC18 is now setup to not use 802.11d and is configured with the correct country code for the network, the normal RD procedure should be used from this point forward.

---

## Wireless Application on the MC18

To configure the MC18, a set of wireless applications provide the user with the tools to configure and test the wireless radio embedded the MC18. The following wireless applications are available on the task tray from the **Wireless Application** menu:

- Wireless Status
- Wireless Diagnostics
- Find WLANs
- Manage Profiles
- Options
- Log On/Off
- Enable/Disable Radio.

Refer to the *Wireless Fusion Enterprise Mobility Suite User Guide for Version X.XX*, for information on configuring wireless profiles, where X.XX indicates the Fusion version. To determine the Fusion version see [Fusion Software on page xii](#).



**NOTE** The Windows CE 7.0 desktop may not be visible because the App Launcher application is active. To view the desktop, close all running applications.

By default, the task tray is displayed below the screen. If the taskbar is set to be hidden, display the task tray by placing your finger over the portion of the task tray that is visible (a thin gray line at the bottom of the screen). The task tray automatically appears.

Touch the **Signal Strength** icon to display the **Wireless Application** menu.

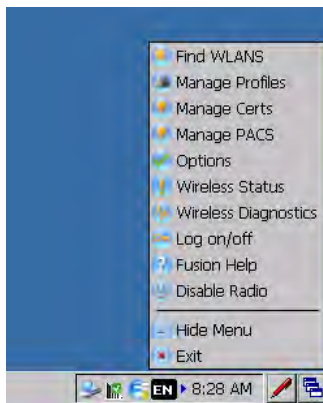

Signal Strength Icon

**Figure 3-1** *Wireless Applications Menu*

## Signal Strength Icon

The **Signal Strength** icon in the task tray indicates the MC18 wireless signal strength as follows:

**Table 3-1** *Wireless Applications Icons, Signal Strength Descriptions*

Icon	Status	Action
	Excellent signal strength	Wireless LAN network is ready to use.
	Very good signal strength	Wireless LAN network is ready to use.
	Good signal strength	Wireless LAN network is ready to use.
	Fair signal strength	Wireless LAN network is ready to use. Notify the network administrator that the signal strength is only "Fair".
	Poor signal strength	Wireless LAN network is ready to use. Performance may not be optimum. Notify the network administrator that the signal strength is "Poor".
	Out-of-network range (not associated)	No wireless LAN network connection. Notify the network administrator.

## Turning Off the Radio

To turn off the WLAN radio click the **Wireless Connection Status** icon on the task tray and select **Disable Radio**.

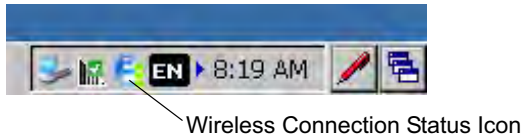

**Figure 3-2** *Wireless Connection Status Icon - Radio On*

A red i appears at the bottom of the icon indicating that the radio is disabled (off).

To turn the radio back on, click the **Wireless Connection Status** icon on the task tray and select **Enable Radio**.

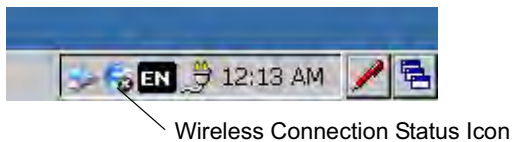

**Figure 3-3** *Wireless Connection Status Icon - Radio On*

The red X disappears from the icon indicating that the radio is enabled (on).

## Bluetooth

Microsoft Bluetooth stack only for printing use case Version 2.1 with EDR compliance Maximum theoretical bandwidth of 921.6Kbps.

The MC18 supports the following Bluetooth profiles:

- Generic Access Profile - GAP
- Service Discovery Access Profile - SDAP
- Serial Port Profile – SPP
- Wake on BT

## Bluetooth Printing

Use this procedure to pair the MC18 to a Bluetooth printer:

1. Launch **BT Explorer** by clicking the BT Icon in notification area.
2. Click **File -> New Connection**.

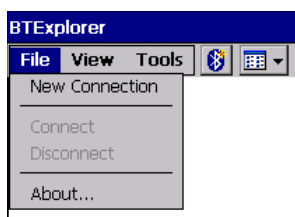

3. Click Next on New Connection wizard to start device discovery.



4. Select the printer and choose next to start pairing process.



5. Enter the PIN. Once the printer is paired with MC18, services of printer are listed.
6. Choose serial printer service and connect.
7. Select the port MC18 to connect to printer.



# CHAPTER 4 SYNC WITH HOST COMPUTER

To communicate with a host computer, the host computer requires a synchronization program. After synchronizing the MC18 with a host computer, changes made on the MC18 or host computer appear in both places.

To communicate with a host computer running Windows XP, install Microsoft ActiveSync (version 4.5 or higher).

To communicate with a host computer running Windows 7, install Windows Mobile Device Center (WMDC version 6.1 or higher).

Using a synchronization software:

- Allows working with MC18-compatible host applications on the host computer. The synchronization software replicates data from the MC18 so the host application can view, enter, and modify data on the MC18.
- Synchronizes files between the MC18 and host computer, converting the files to the correct format.
- Backs up the data stored on the MC18. Synchronization is a one-step procedure that ensures the data is always safe and up-to-date.
- Copies (rather than synchronizes) files between the MC18 and host computer.
- Controls when synchronization occurs by selecting a synchronization mode, e.g., set to synchronize continually while the MC18 is connected to the host computer, or set to only synchronize on command.
- Selects the types of information to synchronize and controls how much data is synchronized.

---

## Installing the Synchronization Software

To install ActiveSync or Windows Mobile Device Center software on the host computer, logon to Microsoft web site at <http://www.microsoft.com>. Refer to the installation instructions included with the software.

## Connecting the MC18 to a Host Computer

Perform this procedure to connect the MC18 to a host computer:

1. Ensure that synchronization program (ActiveSync for Windows XP or Windows Mobile Device Center for Windows 7) is installed properly on the host computer.
2. Using a T8 Torx drive, remove the two Torx screws securing the battery cover to the back housing of the MC18 (see [Figure 4-1](#)).

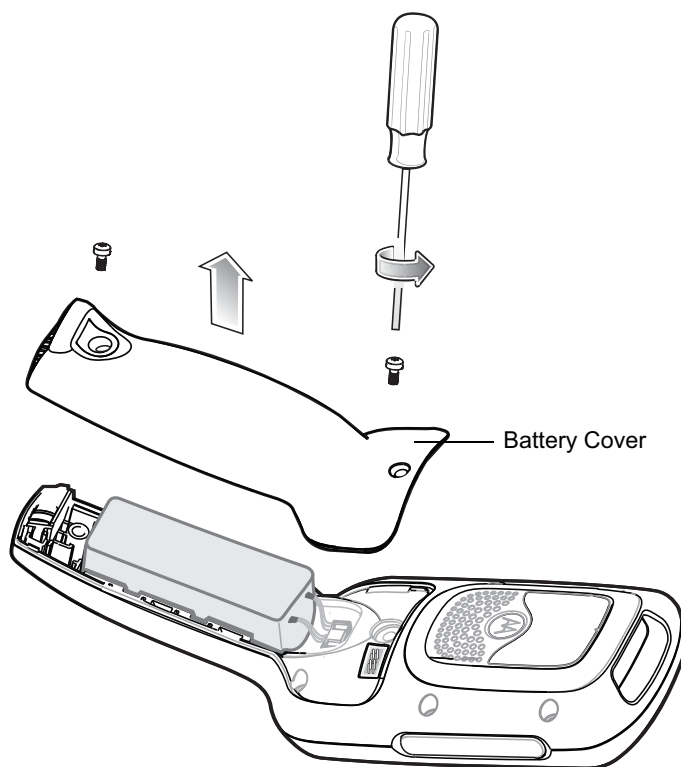
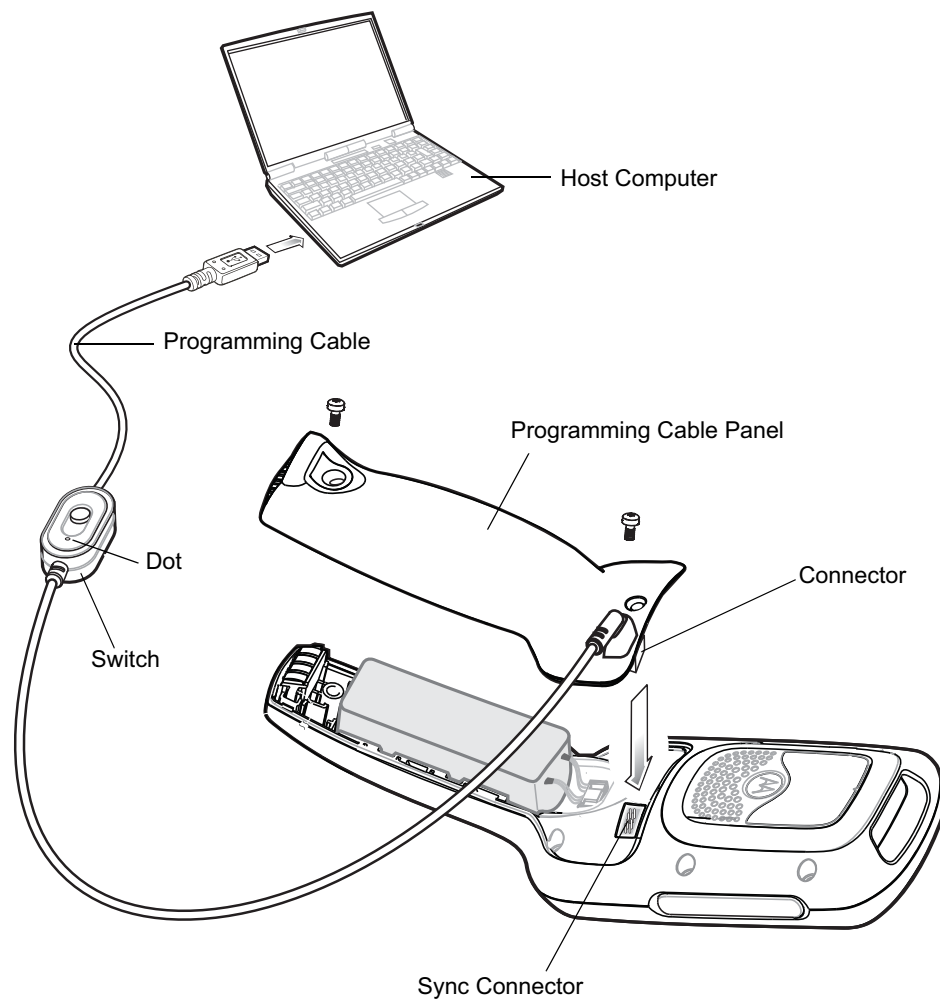

**Figure 4-1** Remove Battery Cover



**CAUTION** Do not remove the battery cover while the MC18 is on and do not operate the MC18 with the battery cover removed. Follow proper Electro-Static Discharge (ESD) precautions to avoid damaging the MC18. Proper ESD precautions include, but are not limited to, working on an ESD mat and ensuring that the operator is properly grounded.

3. Align the connector on the programming cable panel with the sync connector on the MC18 and lower the panel to fit on the MC18.
4. Hand-tighten the two T8 Torx screws securing the programming cable panel to the MC18.



**Figure 4-2** *Installing the Programming Cable*

5. Set the switch on programming cable of the programming cable panel to the side marked with a dot (see [Figure 4-2](#)).
6. Connect the USB connector of the programming cable panel to the Host Computer. The host computer automatically detects the MC18 and starts ActiveSync or Windows Mobile Device Center - the synchronization program window appears on the host computer screen.

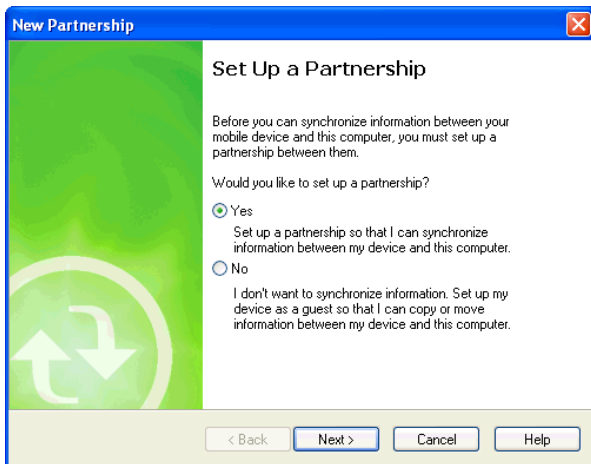

ActiveSync



Windows Mobile Device Center

**Figure 4-3** Synchronization Program Windows

7. For ActiveSync, select the **Yes** radio button to create a partnership with the host computer or **No** radio button to connect as a guest.  
For Mobile Device Center, select **Set up your device** or select **Connect without setting your device** to connect as a guest.
8. For ActiveSync, click **Next**. The Microsoft ActiveSync window indicates that it is connected to the MC18.  
For Windows Mobile Device Center, select the required option.

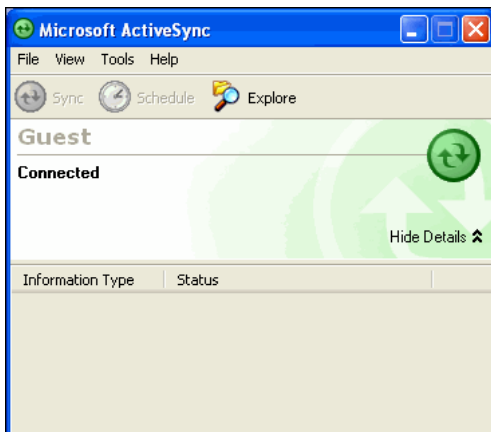

ActiveSync



Windows Mobile Device Center

**Figure 4-4** ActiveSync / Windows Mobile Device Center Connected Window

## Removing the Programming Cable Panel

Perform this procedure to remove the programming cable panel.



**CAUTION** Follow proper Electro-Static Discharge (ESD) precautions to avoid damaging the MC18. Proper ESD precautions include, but are not limited to, working on an ESD mat and ensuring that the operator is properly grounded.

1. Using a T8 Torx drive, loosen the two screws securing the programming cable panel to the MC18.
2. Lift the programming cable panel straight up.

## Installing the Battery Cover

1. Align the battery cover on the MC18 and lower the panel to fit on the MC18.
2. Using a T8 Torx drive, secure with battery cover to the MC18 using the two Torx screws. Torque the screws to 3.6 kgf/cm (3.1 in-lbs).

---

## Setting Up an ActiveSync Connection on the Host Computer (with Windows XP)

✓ **NOTE** The normal function of the product may be disturbed by Strong Electro Magnetic Interference (for example, static electricity). If so, simply remove and re-insert the MC18 to resume normal operation. In case the function does not resume, please use the product in another location.

Use this procedure to start ActiveSync:

1. Select **Start > Programs > Microsoft ActiveSync** on the host computer. The **ActiveSync** window displays.

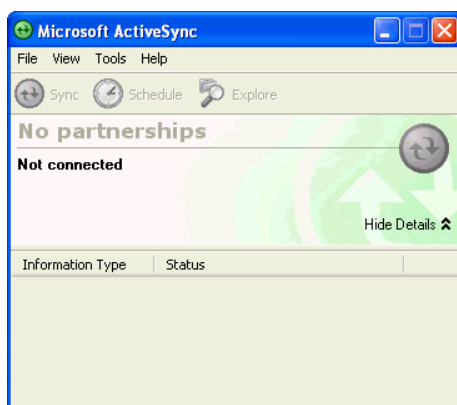

**Figure 4-5** ActiveSync Window

✓ **NOTE** Assign each MC18 a unique device name. Do not try to synchronize more than one MC18 to the same name.

2. In the **ActiveSync** window, select **File > Connection Settings**. The **Connection Settings** window appears.



**Figure 4-6** Connection Settings Window

3. Select **Allow USB connections** check box.
4. Select the **Show status icon in Taskbar** check box.
5. Select **OK** to save any changes made.

## Setting up a Partnership

Use this procedure to set up a partnership:

1. If the **Get Connected** window does not appear on the host computer, select **Start > All Programs > Microsoft ActiveSync**.

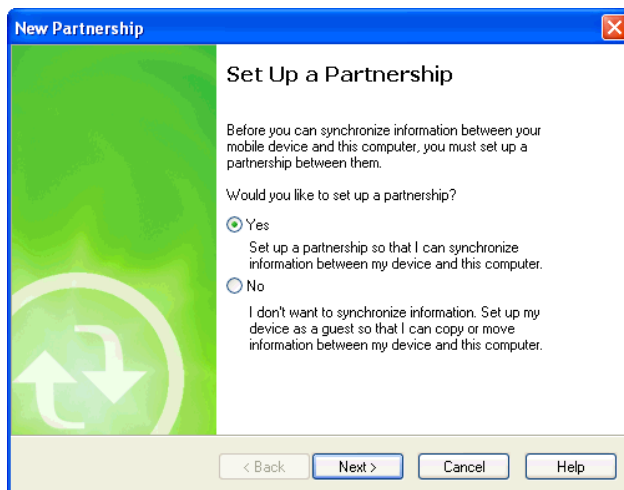

**Figure 4-7** New Partnership Window

2. Select if you want to set up a partnership. Select either the **Yes** or **No** radio button.
3. Click **Next**.
4. If **No** is selected, skip to step 7.

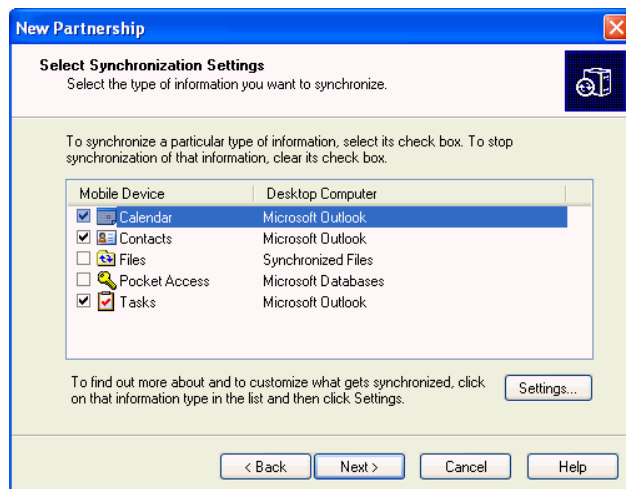

**Figure 4-8** *Select Synchronization Setting Window*

5. Select the appropriate settings and click **Next**.

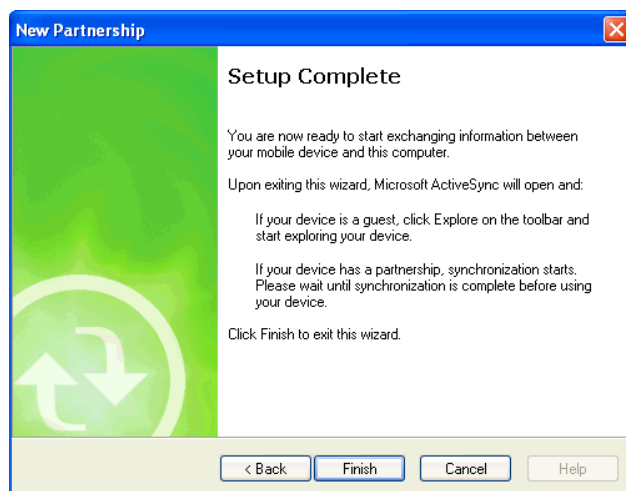

**Figure 4-9** *Setup Complete Window*

6. Click **Finish**.
7. The Microsoft ActiveSync window displays.

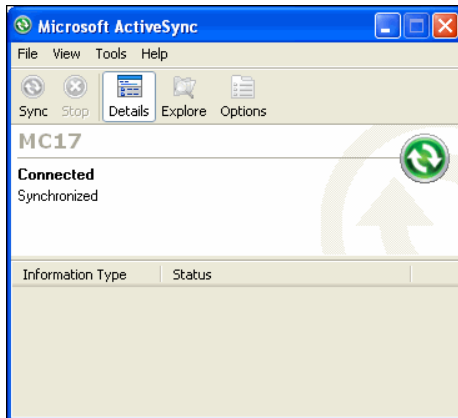

**Figure 4-10** *ActiveSync Connected Window*

During the first synchronization, information stored on the MC18 is copied to the host computer. When the copy is complete and all data is synchronized, the MC18 can be disconnected from the host computer.

- ✓ **NOTE** The first ActiveSync operation must be performed with a local, direct connection. To retain partnerships after a cold boot, capture partnership registry information in a .reg file and save it in the Flash File System. See the detailed information provided in the EMDK Windows CE Help File for Mobile Computers.

For more information about using ActiveSync, start ActiveSync on the host computer, then see ActiveSync Help.

## Setting Up a Windows Mobile Device Center Connection on the Host Computer (with Windows 7)

To set up a Sync connection using Windows 7:

1. Select **Start > All Programs > Windows Mobile Device Center** on the host computer.



**Figure 4-11** *Windows Mobile Device Center (WMDC) Window*



2. In the WMDC window, under **Mobile Device Settings**, click **Connection settings**.

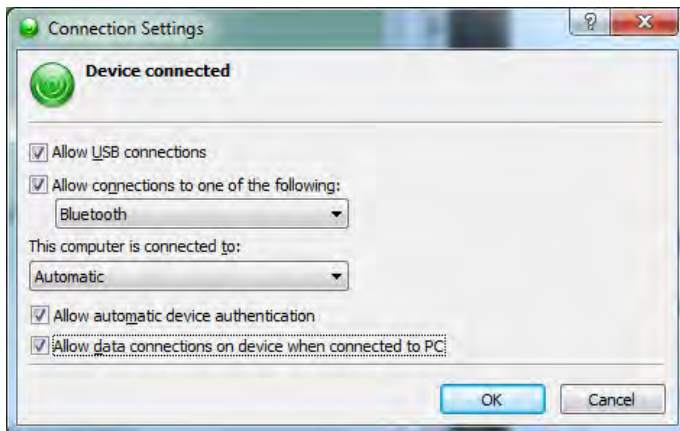

**Figure 4-12** Connection Settings Window

3. Select **Allow USB connections** and adjust any additional settings as needed.
4. Click **OK** to save your settings.

## Setting up a Partnership

To set up a partnership:

1. In the WMDC window, under **Mobile Device Settings**, click **Set up your device**.
2. Check the **Files** check box and click **Next**.

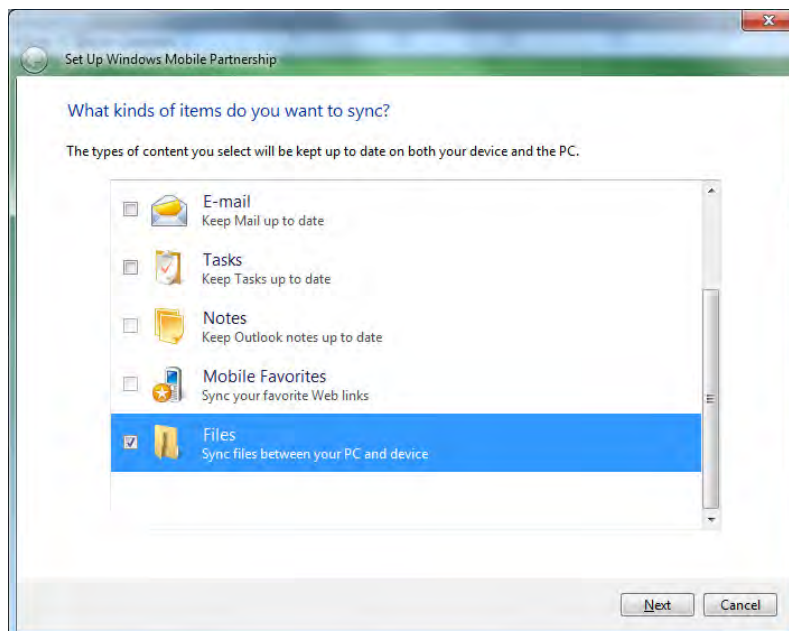

**Figure 4-13** Select Synchronization Setting Window

3. Set your device name and click **Set Up** - the Connected Window will display.

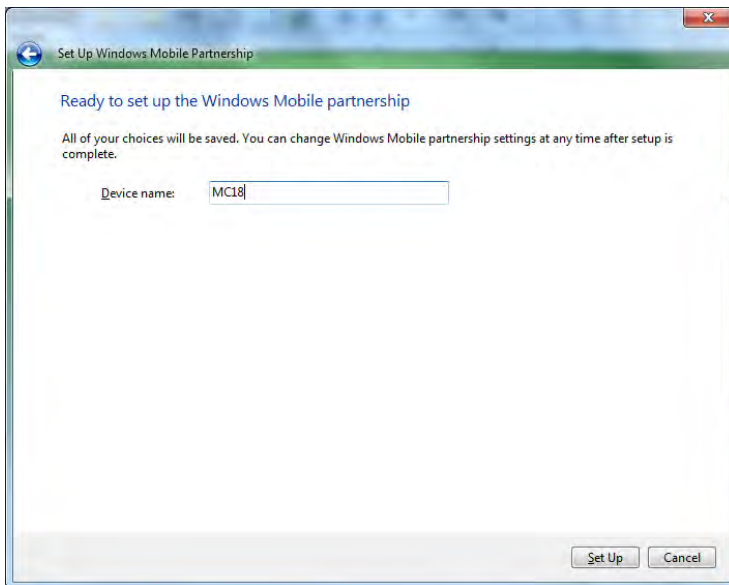

**Figure 4-14** Setup Complete Window



**Figure 4-15** Connected Window

During the first synchronization, information stored on the MC18 is copied to the host computer. When the copy is complete and all data is synchronized, the MC18 can be disconnect from the host computer.

For more information about using WMDC, start the application on the host computer, then see Help.

# CHAPTER 5 USING THE WINDOWS CE DESKTOP

---

## Introduction

The MC18 runs Windows CE 7.0 operating system and the operating system is only available for configuration when connected to a host computer via sync program.

The MC18 enabled device is available using the user interface (UI).

---

## App Launcher Window

The **App Launcher** window allows the user to launch specific applications by tapping on a menu an item. If the **App Launcher** window is closed, launch the **App Launcher** window by touching the **App Launcher** shortcut on the MC18 desktop or selecting **AppLauncher.exe** in the **Start > Programs > Windows Explorer** directory.

See [Appendix B, App Launcher Configuration](#) for instructions on modifying the **App Launcher** menu.

✓ **NOTE** App Launcher window may vary depending upon the operating system version.

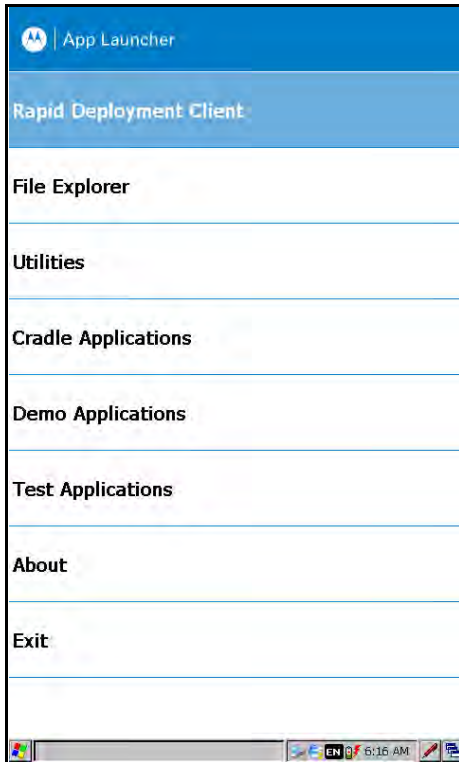

Figure 5-1 App Launcher Window

Table 5-1 App Launcher Item Descriptions

Item	Description
<b>Rapid Deployment Client</b>	Launches the Rapid Deployment application.
<b>File Explorer</b>	File Explorer enables working with files, folders and network on the MC18.
<b>Utilities</b>	Provides easy access to most used applications such as Internet Explorer.
<b>Cradle Applications</b>	Provides for cradle software update, control and settings and diagnostics applications.
<b>Demo Applications</b>	Provides applications that demonstrate the operation of the MC18 such as scan application.
<b>Test Applications</b>	Provides applications for performing diagnostics and testing of the MC18.
<b>About</b>	Displays information about the App Launcher.
<b>Exit</b>	Closes the Up Launcher window.

## Windows CE 7.0 Desktop

- ✓ **NOTE** The Windows CE 7.0 desktop may not be visible because the App Launcher application is active. To view the desktop, close all running applications.

The following paragraphs describe the Windows CE 7.0 desktop. Depending upon the customer's configuration of the MC18, the desktop may not be available.

### Status Icons

The Taskbar at the bottom of the window displays the active programs, battery status and communication status. The taskbar (at the bottom of the screen) displays the **Start** button, active programs, battery status and communication status. The taskbar icons are described in [Table 5-2](#). The taskbar icons display the function status, indicate what programs are active and indicate the battery charge status. The Taskbar buttons are used to access menus, select/deselect functions or to change display windows.

- **Active Programs Icons:** The active applications icons are displayed on the taskbar. If more than one program is active, icons can be used to toggle between the open programs (applications). Touch on a taskbar application to maximize the application.
- **AC Power/Battery Status Icons:** The AC Power/Battery Status icons are shown in the taskbar to indicate the present power supply status of the MC18. The battery status icons provide the battery status in 10% increments from 10% to 100%.

The Taskbar is shown on the lower part of the MC18 screen. To set the properties of the taskbar, see [Properties on page 5-6](#).



**Figure 5-2** Taskbar

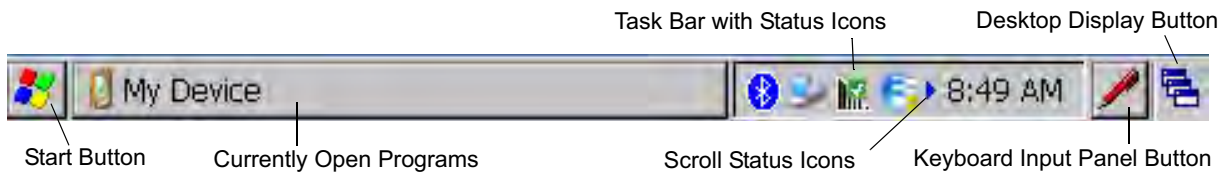









Figure 5-3 Taskbar

Table 5-2 Taskbar Icons

Icon	Description
	Indicates that the battery is charging.
	Indicates that the battery is fully charged (100% charged). The battery status icons provide the battery status in 10% increments from 10% to 100%.
	Indicates that the battery is fully charged and the MC18 is running on external power.
	Indicates IP status. Only displays when the MC18 is in emulation mode.
	Indicates that the Sync application is running.
	Indicates that the wireless application radio is connected to a wireless LAN network with excellent signal strength.
	Indicates that the wireless application radio is not connected to a wireless LAN network.

## Start Button

Touch the **Start** button to launch the *Start* menu.

- *Programs*: Use to access available programs.
- *Favorites*: Displays files in *Favorites* directory.
- *Documents*: Displays files in *Documents* directory.
- *Settings*: Accesses the Control Panel, the Network and Dial-up Connections and the Taskbar and *Start* menu.
- *Help*: Accesses the Windows CE Help.
- *Run . . .*: Runs a program or application.
- *Suspend*: Places the MC18 in the suspend state.

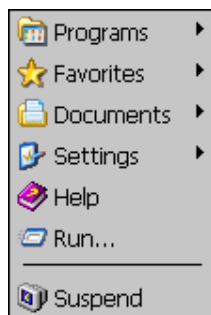

Figure 5-4 Start Menu

## Programs Menu

From the **Start** menu, click **Programs** to launch the **Programs** menu. Refer to the Application Guide for *Symbol Technologies Enterprise Mobility Devices*, p/n 72-68901-xx and the *Microsoft® Applications for Windows Mobile and WinCE 7.0 User Guide*, p/n 72E-78456-xx for application information.

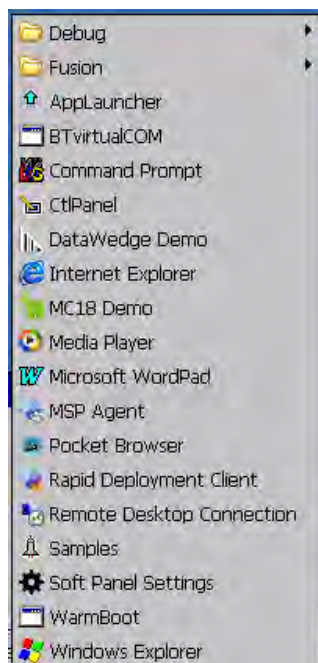

Figure 5-5 Programs Menu

## Desktop Display Button

Use the **Desktop Display** button to minimize all open programs and display the desktop.

## Entering Information Using the Keyboard Input Panels

Use the keyboard input panels (soft keyboard) to enter information in any program. To launch the keyboard input panel, click the  button on the taskbar. Select the type of input panel (Keyboard or XAMLIM). Touch a key to enter the value. Touch the keyboard input panel button to display or to hide the keyboard input panel.



Figure 5-6 Keyboard Input Panel

## Task Bar and Start Menu Properties

Use the **Properties** functions to set display and clock options.

### Properties

1. Touch **Start > Settings > Taskbar and Start Menu ...**. The **Taskbar and Start Menu** window displays.

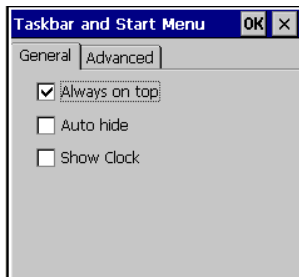

Figure 5-7 Taskbar and Start Menu- General Tab

2. This window provides taskbar options:
  - Check the **Always on Top** check box to keep the taskbar on top of all other windows.
  - Check the **AutoHide** check box to make the taskbar disappear, click the bottom of the display to make the taskbar return.
  - Check the **Show Clock** check box to display the clock on the taskbar.
3. Touch **OK** to save the settings and exit the window.

### Advanced Tab

1. Touch the **Advanced** tab.



2. Touch the **Clear** button to delete all of the documents listed in the **Start > Documents** entry, see [Start Button on page 5-4](#). Typically this list is empty, but if there were documents in the list the **Clear** button would delete them.
3. Touch the **Expand Control Panel** check box to display the entire contents of the Control Panel in list form, rather than icons.



**Figure 5-8** Taskbar and Start Menu-Advanced Tab

4. Touch **OK** to save the settings and exit the window.

## Waking the MC18

The wake up conditions define what actions wake up the MC18 after it has gone into suspend mode. The MC18 can go into suspend mode automatically by control panel time-out settings. These settings are configurable and the factory default settings are shown in [Table 5-3](#). To set the wake up conditions select **Start > Settings > Control Panel > Power icon > Wakeup** tab.

**Table 5-3** Wakeup Default Settings

Condition for Wakeup	Automatic Time-out
Touch Panel (Screen)	No
Trigger 1 (Scan key)	Yes
USB Cable	Yes



**Figure 5-9** Wakeup Tab



# CHAPTER 6 SPECIAL CONSIDERATIONS

---

## Introduction

The chapter provides information for:

- Using language fonts
- software development considerations
- Improving battery charge time
- Improving battery life
- Cradle applications
- MC18 Hardware Diagnostics

---

## Fonts

The MC18 supports the following language fonts:

- English
- French
- Italian
- German
- Spanish
- Swedish
- Russian
- Greek (fonts support only)
- Arabic (fonts support only)

The MC18 supports the installation of font libraries for use with application and web development. Simplified Chinese, Korean, and Japanese font libraries are available on the Support Central Web site, <http://supportcentral.motorola.com>. Other standard UTF-8 encoded fonts are available from third party font

vendors. Developers should refer to Microsoft and third party vendor documentation for development and usage details.

It should be noted that installing a language font library will not change the language configuration of the operating system image, i.e., Windows messages will still be displayed in the language designated in the factory supplied operating system image.

## Asian Font Installation

The Asian fonts must be installed onto the MC18.

Use this procedure to install Asian fonts onto the MC18.

1. Download the font package from Support Central.
2. Copy the language font files into the *Application* folder on the MC18:
  - .ttf, .ttc or .ac3 files
  - .reg files (required for Asian fonts)
  - .cpy files.
3. Cold boot the MC18.

After the MC18 re-boots, the installed fonts are available for use.

Refer to <http://msdn2.microsoft.com/en-us/library/aa911446.aspx> for an explanation of font usage and installation.

---

## Software Development Considerations

- Dim or turn off the backlight when the MC18 is idle.
- Whenever possible use default key code settings.
- To improve performance, use RAM instead of flash memory.
- Always lock the cradle after unlocking it.
- Cold booting the MC18 erases all files in RAM. Be sure to save any critical files in *Application* folder, e.g.; Radio profile, time zone setting, license keys etc.
- User developed applications should provide a method for exiting or launching Rapid Deployment to enable re-staging the MC18.
- For detailed information on how to control the cradle LEDs and locking/unlocking the MC18 in the cradle, refer to the EMDK Help file.

---

## Tips for Improving Battery Charge Time

To improve battery charging time:

- Avoid unnecessary wireless communication while the MC18 is in the cradle.
- Use maximum power save mode when setting up the wireless profile. (This greatly improves charging time since the radio accounts for a large amount of power).
- Ensure there is a good wireless signal nearby (a poor signal causes the radio to enter high power mode much more often than normal.)
- Turn off display while in the cradle.

## Tips for Improving Battery Life

The MC18 has many functions to allow server/client applications control over its power management. To improve battery life:

- Place the MC18 in a cradle connected to AC power when not in use.

✓ **NOTE** In suspend mode, the radio cannot communicate with an AP.

- After the customer check-out, place the MC18 in suspend mode. This prevents the MC18's battery from discharging while sitting at a counter before being returned to the cradle. Once inserted in the cradle, the MC18 wakes up automatically.
- If placed in suspend mode, scan key press can be set to wake up the MC18. This can greatly increase battery life.
- If the user application does not allow placing the MC18 in suspend mode, turn off the backlight after the time-out period.
- Set the backlight brightness to the minimum required by the application.
- Ensure a good wireless signal.
- Set the wireless profile to MAX Power Save mode. If CAM mode is selected, the device does not maximize power savings.

Running time for the MC18 is expected to be approximately 6 to 7 hours with the following profile:

- 2 scans/minute
- transmitting 32K bytes of data per scan
- 75% display brightness
- 50% On/Off backlight
- Associate to an access point (AP) with "Good" signal strength and configure the wireless profile to MAX Power Save mode.

## Changing the Power Settings

✓ **NOTE** Use remote control software to navigate the operating system. See [Chapter 5, Using the Windows CE Desktop](#) for instructions.

Use this procedure to set the MC18 to turn off after a short period of non-use:

1. Select **Start > Settings > Control Panel > Power icon > Advanced** tab.
2. Select the **On battery power: Turn off device if not used for:** check box and select a value from the drop-down list box.
3. Select **OK**.

## Changing the Display Backlight Settings

✓ **NOTE** Use remote control software to navigate the operating system. See [Chapter 5, Using the Windows CE Desktop](#) for instructions.

Use this procedure to change the display backlight settings to conserve battery power:

1. Select **Start > Settings > Control Panel > Backlight icon > Battery Power** tab.
2. Select the **On battery power: Disable backlight if not used for:** check box and select a value from the drop-down list box.
3. Select the **Brightness** tab.
4. Select the **Disable backlight** check box to completely turn off the display backlight.
5. Use the slider to set the brightness of the backlight. Set it to a low value to save battery power.
6. Select **OK**.

The display backlight value can also be set using a registry setting.

✓ **NOTE** By default, backlight is set NOT to time-out on user inactivity – this can be modified using the Backlight control panel applet.

Key Name: [HKEY\_CURRENT\_USER\ControlPanel\BackLight]

"BatteryTimeout"=dword:00000000 ; timeout set to never

"ACTimeout"=dword:00000000 ; timeout set to never

---

## Cradle Utility

The cradle Utility enables to:

- Updating the cradle firmware
- Setting and controlling the cradle
- Performing cradle diagnostics
- Viewing cradle information

## Cradle Firmware Update

The CradleFWUpdater application allows to manually update cradle firmware using MC18 terminal.

Use this procedure to update Cradle Firmware:

1. Using a synchronization program, copy the new firmware file to the MC18 (see [Chapter 4, Sync with Host Computer](#)).
2. On the home screen of the MC18, double click the **AppLauncher** icon.  
**Result:** The App Launcher screen is displayed.

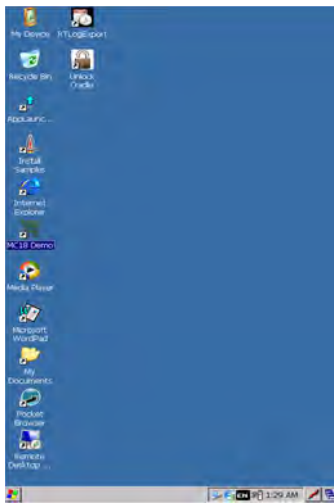

**Figure 6-1** MC18 Home Screen



3. On the App Launcher screen, click **Cradle Applications**.  
**Result:** The **Cradle Applications** menu is displayed

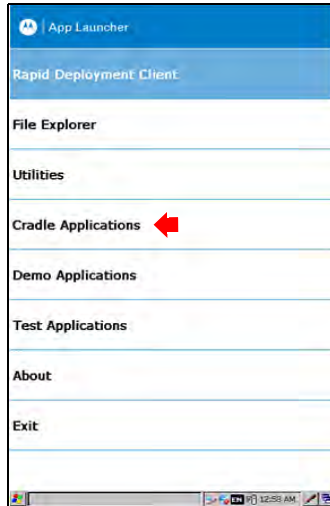
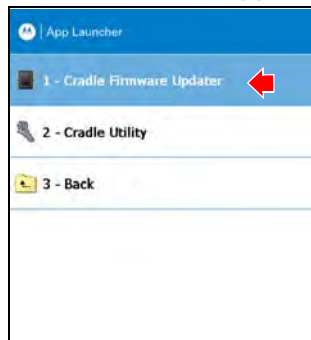
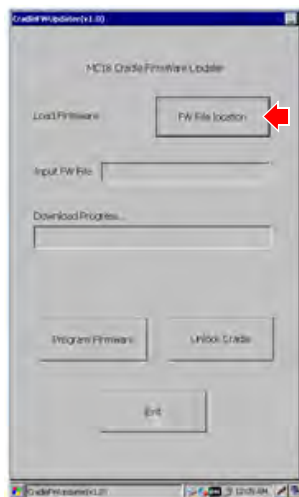

Figure 6-2 App Launcher Screen

4. On the **Cradle Applications** menu, click **Cradle Firmware Update**.



5. Dock the MC18 inside the cradle.  
 6. Double click **FW File location**.  
**Result:** The **Select HEX** box is displayed.



7. From the **Select HEX box**, select a firmware file and click **OK**.

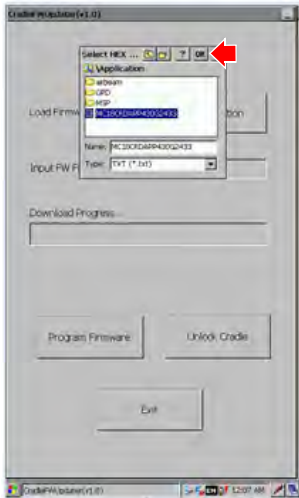

8. Click **Program Firmware**. A warning box displays **Please don't remove the device from the cradle until PW Update completes**.
9. Click **OK** to initiate the firmware update process.

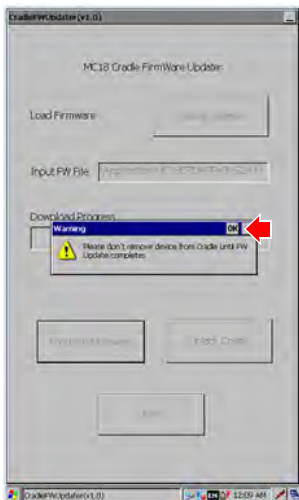

- ✓ **NOTE** During the firmware initiation process, the application resets the cradle. If the following error box displays: **Please manually reset the cradle and then press "OK" button**. The user is required to manually reset the cradle.

Perform this procedure to manually reset the cradle:

- a. Disconnect power from the power supply unit of the cradle.
- b. Reconnect power to the power supply unit of the cradle.
- c. Click **OK** before the LEDs on the cradle start glowing, to remove the error message and continue. Failing to click OK before the LEDs starts glowing will re-display the error message. If user fails continuously 5 times, the firmware update process stops.
- d. If application is successful, it will start downloading process as from step 6.

1. After resetting the cradle, the application starts the firmware download process.

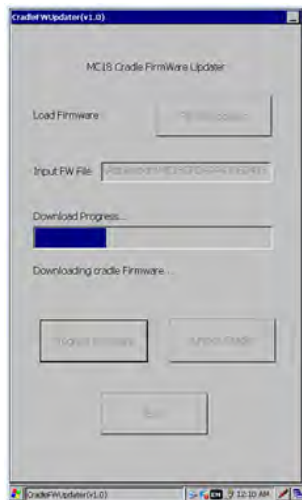

2. When **Download Complete** is displayed on the screen, the firmware update process is completed successfully. Click **Unlock Cradle** to unlock and remove the MC18 from the cradle.

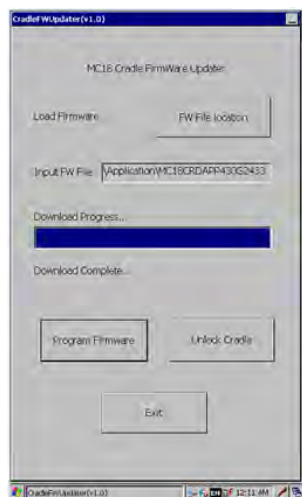

## Setting and Controlling the Cradle

- ✓ **NOTE** Setting and Controlling the cradle can also be done through the Pocket Browser application.

The Cradle Utility application allows to manually set and control cradle features.

- **Unlock:** enables to set a 10 to 30 seconds time-out delay before the MC18 is releases from the cradle.
- **Cradle Information:** Setting or retrieving the cradle ID and location (row, column and dispenser wall).

- ✓ **NOTE** The cradle ID and location information and charge settings is retained across firmware upgrades.

- **Setting the cradle charging rate:** Depending on the cradle installation configuration, the store technician can configure each individual cradle slots to enable/disable fast charge. Each cradle can be configured

to charge its docked terminal at 1Ah (normal charging mode - default setting) or 1.5Ah (fast charging mode).

✓ **NOTE** The cradle charging rate is retained across firmware upgrades.

Use this procedure to set and control the cradle:

1. Dock the MC18 inside the cradle.
2. On the home screen of the MC18, double click the **AppLauncher** icon on the home screen of the MC18  
Result: The App Launcher screen is displayed,



3. On the App Launcher screen, click **Cradle Applications**.  
Result: The **Cradle Applications** menu is displayed

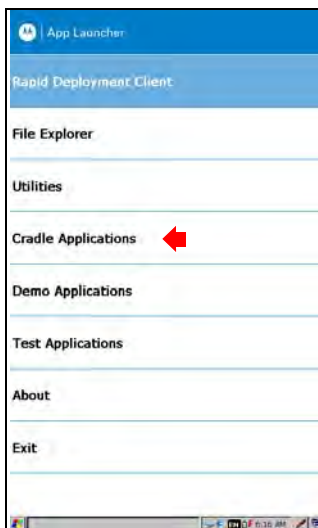

4. On the **Cradle Applications** menu, click **Cradle Utility**.

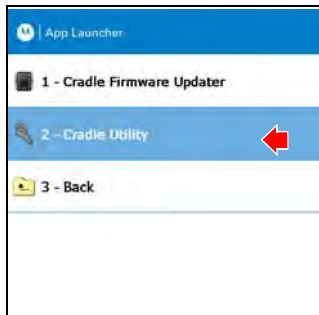

5. Click the **Settings** tab to set the cradle information:

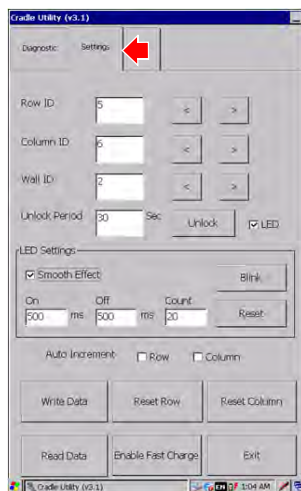

- a. **Row ID:** The cradle row number in the dispenser wall.
- b. **Column ID:** The cradle column number in the dispenser wall.
- c. **Wall ID:** The number of dispenser wall where the cradle is positioned.
- d. **Unlock Period:** The number of seconds that pass from the time the unlock signal is received to unlocking the MC18 from the cradle.
- e. **Unlock:** Press **Unlock** to manually unlock the MC18 from the cradle.
- f. **LED:** Check the LED box to enable the cradle LED indication.
- g. **Smooth Effect:** Check the Smooth Effect box to enable soft on/off blink of LED.
- h. **LED Setting > On:** The cradle LED is set to blink during unlock. Set the duration that the LED remains off.
- i. **LED Setting > Off:** The cradle LED is set to blink during unlock. Set the duration that the LED will remain off during a blink.
- j. **LED Setting > Count:** The cradle LED is set to blink during unlock. Set the number of blinks that the LED after receiving an unlock signal.
- k. **Blink:** Click to test the cradle LED operation.
- l. **Write Data:** Program the information shown on the screen to the cradle memory.
- m. **Reset Row:** Remove row information from the cradle memory.
- n. **Reset Column:** Remove column information from the cradle memory.

- o. **Read Data:** Retrieve setting data from the cradle memory and display on the screen.
- p. **Enable Fast Charge:** Enable the cradle to charge the MC18 at a current of 1.5A (default setting is 1A)
- q. **Exit:** Exit the **Cradle Applications** menu.

## Performing Cradle Diagnostics

1. On the home screen of the MC18, double click the **AppLauncher** icon.  
**Result:** The App Launcher screen is displayed.
2. On the **AppLauncher screen**, double click **Cradle Applications > Cradle Utility**.
3. Click the **Diagnostics** tab to perform the cradle diagnostics:
  - a. **Cycle Reading:** Check the **Cycle Reading** box to perform continues diagnostics and display the cradle status information. During diagnostics, a progress bar is shown of the screen.
  - b. **Import Data:** Click to save the recorded results of the diagnostics on a file.
  - c. **Read Data:** Click to start performing diagnostics.

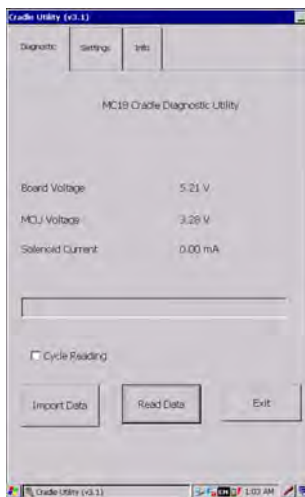

## Viewing Cradle Information

1. On the home screen of the MC18, double click the **AppLauncher** icon.  
**Result:** The App Launcher screen is displayed.
2. On the **AppLauncher screen**, double click **Cradle Applications > Cradle Utility**.

3. Click the **Info** tab to read the cradle information:



---

## MC18 Hardware Diagnostics

MC18 has an in built diagnostics engine that test the following hardware sections:

- Battery health in percentage
- Battery remaining capacity in minutes
- Battery remaining capacity in percent (while charging and discharging)
- Battery manufacturing date
- Time remaining in minutes to be put in cradle for 'x' minutes of shopping trip
- Time since battery was replaced last
- Duration in which the battery was charged during the current charge cycle
- Time since last reboot.

Use this procedure to view hardware diagnostics to the MC18

✓ **NOTE** Performing hardware diagnostics to the MC18 can also be done through the Pocket Browser application.

1. On the App Launcher screen, click **Test Applications**.  
**Result:** The **Test Application** menu is displayed

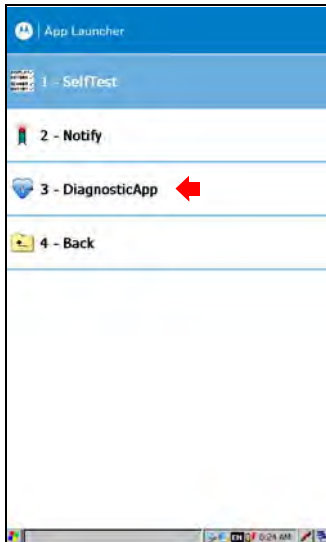

2. Click **DiagnosticApp**. |  
**Result:** The Diagnostic Test App screen is displayed.

The screenshot displays the 'Diagnostic Test App V1.4' window. The title bar includes 'OK' and 'X' buttons. The main content area is titled 'Diagnostic Data' and is divided into four sections:

- Generic Diagnostic Data:**
  - Battery Health: 100 %
  - State of Charge: 79 %
  - Battery Manufacture Date: 12/23/2013
  - Days since battery was last replaced: 2 Days
  - Time Since last ReBoot: 3 Mins
- Battery Dependent Data:**
  - Time to Battery Empty: 559 Mins
- AC Dependent Data:**
  - Required time in mins for unit to remain in cradle for a shopping trip of "x" mins: 0 Mins
  - Battery has been Charging for: 0 Mins
- Input Data:**
  - Shopping Time in "x" mins: 1 Mins
  - Average Current Consumption: 1 mA

At the bottom of the form are 'EDIT' and 'SAVE' buttons. The Windows taskbar at the bottom shows 'DIAGApITest' and the time '12:03 AM'.

**Figure 6-3** Diagnostic Test App Screen



## Soft Button Panel

The Soft Button Panel application enables to create a soft button panel at the lower part of the MC18 screen. The soft button panel includes three buttons that can be customize to perform the following basic keyboard operations:

- Up
- Down
- Escape (Esc)
- Enter
- Left
- Right

Use this procedure to create and configure a soft button panel:

1. From the home screen of the MC18, click **Start > Programs > Soft Panel Settings**.

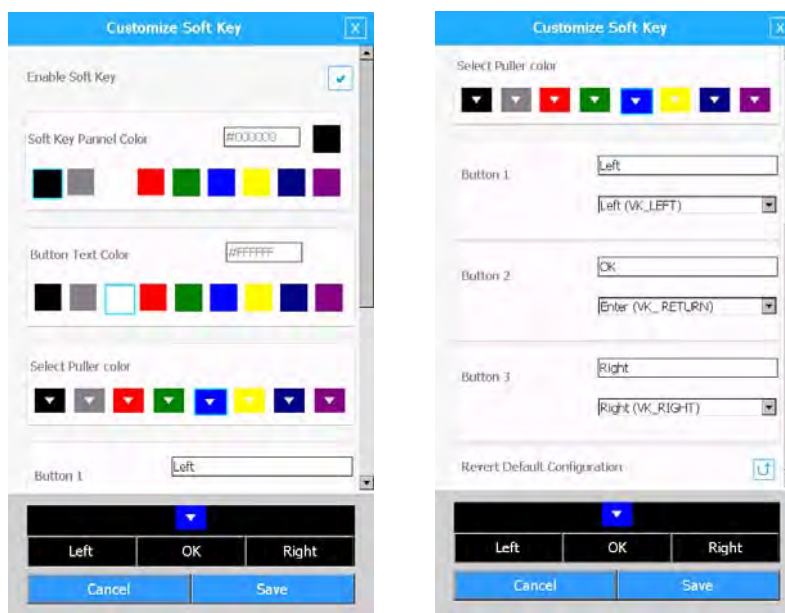

**Figure 6-4** *Soft Panel Settings Window*

2. Check the **Enable Soft Key** box to enable settings.
3. Using the provided pallets, select the soft keys panel, buttons and puller color.
4. Scroll to the button of the window and type the text that will display on each button.
5. Use the drop menu to select the operation of each button.
6. Click **Save**.

## MC18 Demo Application

The MC18 Demo application enables the customers to develop a self-service shopping assistance application.

The demo application can be custom to reflect your brand name, logo and text colors.

The application provides customers the following:

- Plan a shopping list(s) at home and follow the list as they shop.
- Scanning products as they shop, customers get accurate data before they pay.
- Get total cost and saving information as they shop.
- Target promotions based on the record of their shopping history.
- Help find the products they are looking for and suggests related items to complement their primary purchase.

### Demonstrating the Application

To demonstrate the demo application:

1. To start creating a demo application, tap **Start > Programs > MC18 Demo** - the MC18 Demo Application start screen is displayed.

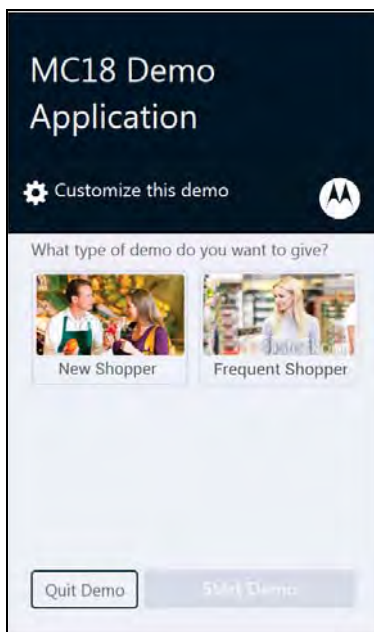

**Figure 6-5** MC18 Demo Application Start Screen

2. Tap on **New Shopper** to demo the experience of a new shopper or **Frequent Shopper** to demo the experience of a frequent shopper.

3. Tap **Start Demo** to start the demonstration - the Welcome Shopper Screen is displayed.

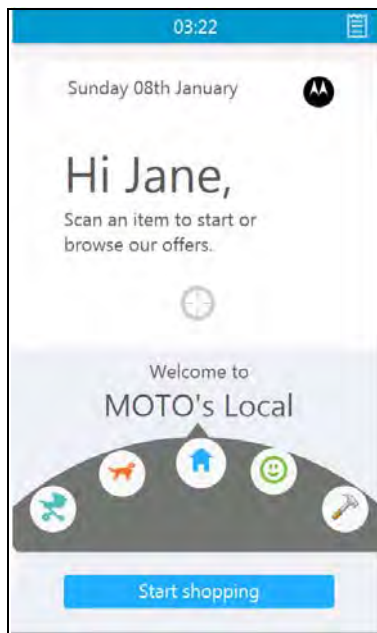

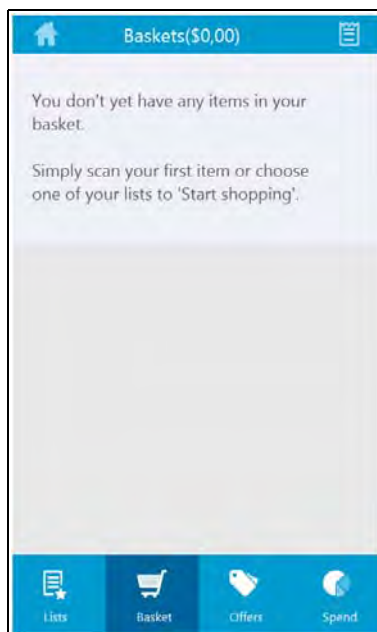

**Figure 6-6** Shopper Welcome Screen

4. Scan a product bar code to start shopping. Alternatively, turn the shopping dial left or right to view and select offers, tips and social media content or tap **Start shopping** to see your Basket Screen.



**Figure 6-7** Basket Screen

5. On the basket screen, tap a navigation icon to display:
  - **Lists:** Select a shopping lists with your products. A shopping list created at the customer home will show and followed shopping. The status of the products is indicated by the following icons:

-  : Product on your shopping list that was not purchased yet
-  : Product on your shopping list that you have purchased
-  : Product you have purchased that was not on your shopping list.

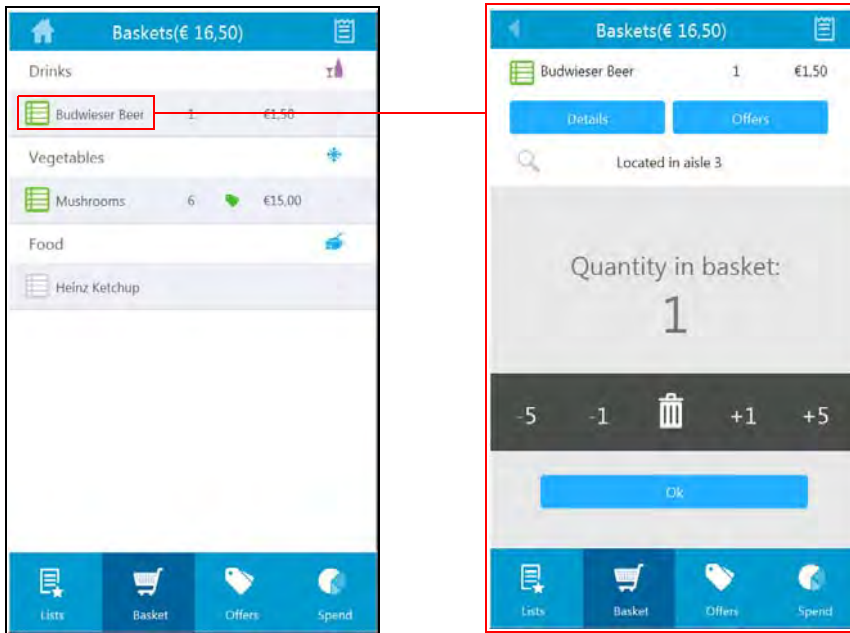

Figure 6-8 Basket Screens

- **Basket:** A list of all scanned products in your basket
- **Offers:** List of special offers and location of the product on an aisle

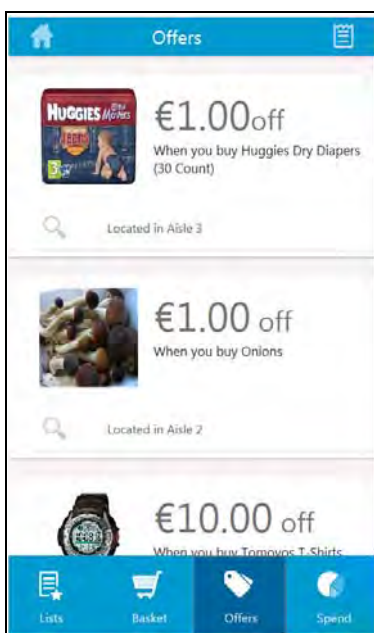
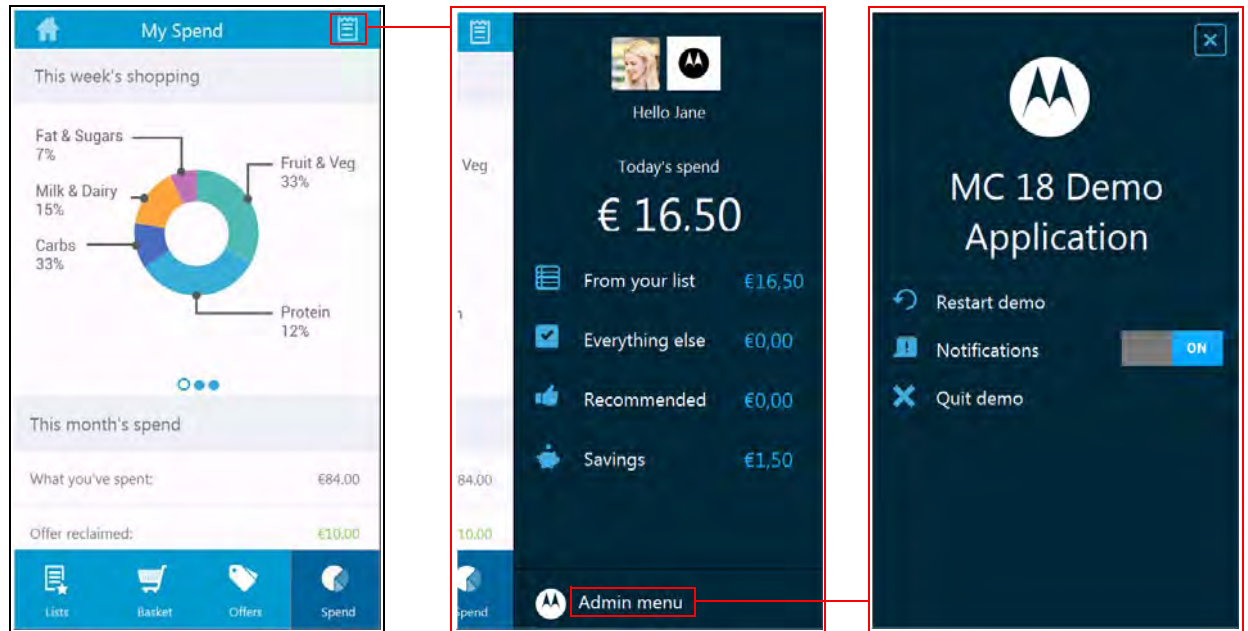





Figure 6-9 Offers Screen

- **Spend:** Weekly and monthly spending information and analysis



**Figure 6-10** Spend Screen

-  : Tap to return to shopper welcome screen
-  : Tap to display today's spend information
-  Admin menu : Tap to restart, quit or enable/disable notifications

## Customizing the Application

To customize the application:

1. From the MC18 Demo Application start screen is displayed, tab **Customize this demo**.

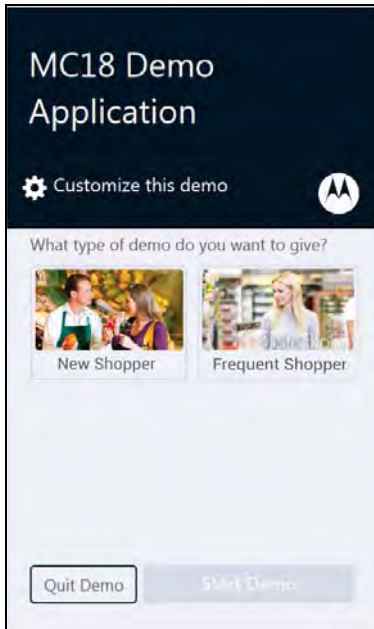

**Figure 6-11** MC18 Demo Application Start Screen

2. In the Customize Demo screen, enter Brand name, Logo and set the color of header and text.

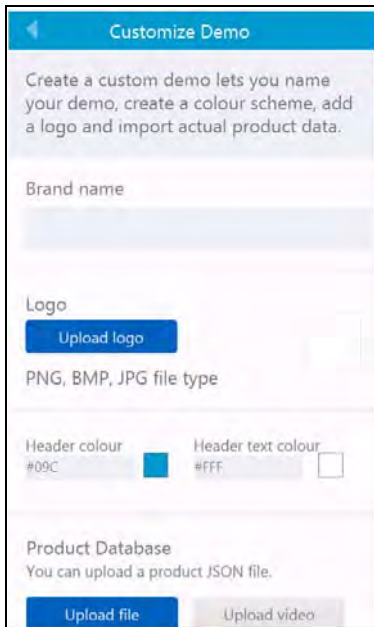

3. Use the **Upload file** option to upload a database file in JSON (JavaScript Object Notation) format from the MC18 or a web location.
4. Use the **Upload video** option to upload a video file from the MC18 or a web location.

# CHAPTER 7 POCKET BROWSER

---

## Introduction

This feature-rich, mobile application development tool is designed to allow Web developers to rapidly create robust mobile applications that can include a wide range of advanced data capture capabilities. Whether you want to streamline your warehouse, delivery or service operations, or enable more robust asset tracking or visibility, Pocket Browser will help you get your enterprise mobility solution up and running faster — and more cost efficiently.

The Pocket Browser Developer Help provides detailed information about how to use each feature of the browser. Each feature includes a sample for you to use, however, please be aware that the sample does not necessarily show the only way to implement each feature.

Pocket Browser enables developers and integrators to provide advanced Web-based solutions to select Microsoft® Windows Mobile and Windows CE mobile computers. PocketBrowser makes the most of enterprise-level applications while speeding up development time and reducing costs. With it, making the transition to web-based solutions is now fast, easy and affordable - especially in high-volume mobile environments.

Pocket Browser is a software tool that extends the core rendering engine functionality of Microsoft PocketIE or Microsoft IE with Symbol Technologies application programming interfaces (APIs). It provides interfaces to the MC18 hardware and features using meta tags and Microsoft ActiveX® components designed specifically for Symbol Technologies systems. Pocket Browser offers easy integration with bar code scanners, RFID readers and other peripherals such as printers and magnetic stripe readers (MSR) for complete transaction processing.

---

## Sample Application

The MC18 comes with a sample PocketBrowser v 3.1.0 applications factory-installed. The sample application is accessible from the **Programs** menu.

To start PocketBrowser, select **Start > Programs > Pocket Browser**. The PocketBrowser window appears.

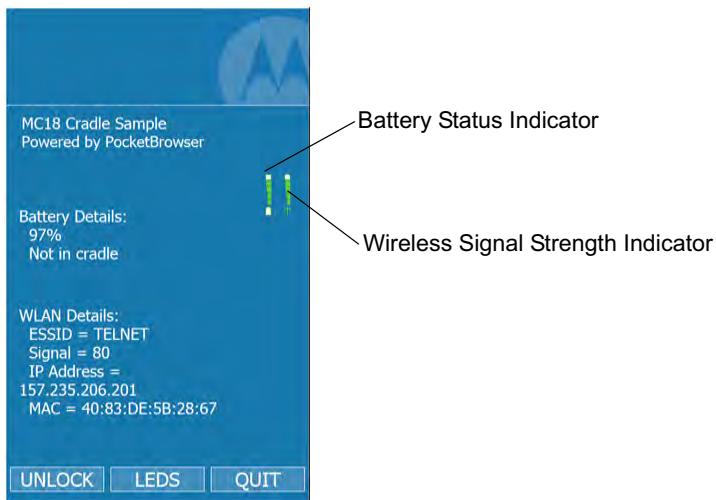

**Figure 7-1** Sample PocketBrowser Screen

The sample PocketBrowser provides the following information:

- Battery level status bars
- WLAN signal strength status bars
- Battery Details:
  - Battery strength in percentage
  - Battery change / no charge status
- WLAN details:
  - ESSID name
  - Signal
  - IP Address of the MC18
  - MAC address of the MC18

The three buttons at the bottom of the screen:

- UNLOCK/LOCK - Unlocks and locks the MC18 into the cradle
- LEDS - Illuminates the cradle LEDs
- QUIT - Exits the sample PocketBrowser application

## Configuring the Pocket Browser

The information on the Pocket Browser startup page can be configured by changing the Config.xml file (from the MC18 root directory, select **Program Files > PocketBrowser > Config > Config.xml**). Before launching the Pocket Browser for configuration, the MC18 must be connected to a network.



# CHAPTER 8 CRADLE INSTALLATION

---

## Introduction

A system is comprised of a family of hardware devices interconnected through a WLAN radio backbone to the retail establishment's server(s). The hardware devices are the MC18 mobile computers, single-slot or three slot cradles, power supplies and cables. A *dispenser* typically refers to a piece of furniture which has mounted to it the cradles, their power supplies, and cables.

Customers (retail establishments) design their own dispensers to meet their particular floor space and display requirements. The information in this chapter should help a customer to design a dispenser and to understand the installation requirements.

✓ **IMPORTANT** The MC18 cradles are NOT compatible with MC17 cradles and the MC17 cradles are NOT compatible with MC18 cradles.

---

## Installation of the Single-Slot Cradle

### Removing the Front Cover

Use this procedure to remove the front cover:

1. Loosen two captive screws securing the front cover to the base.

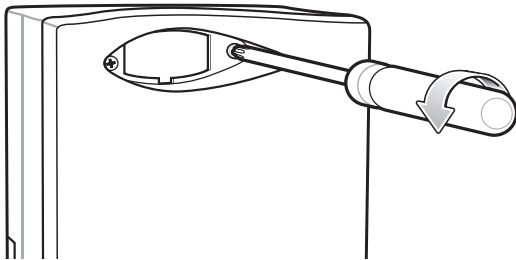

**Figure 8-1** Remove Screws

2. Pull front cover away from base and then lift out of the base.

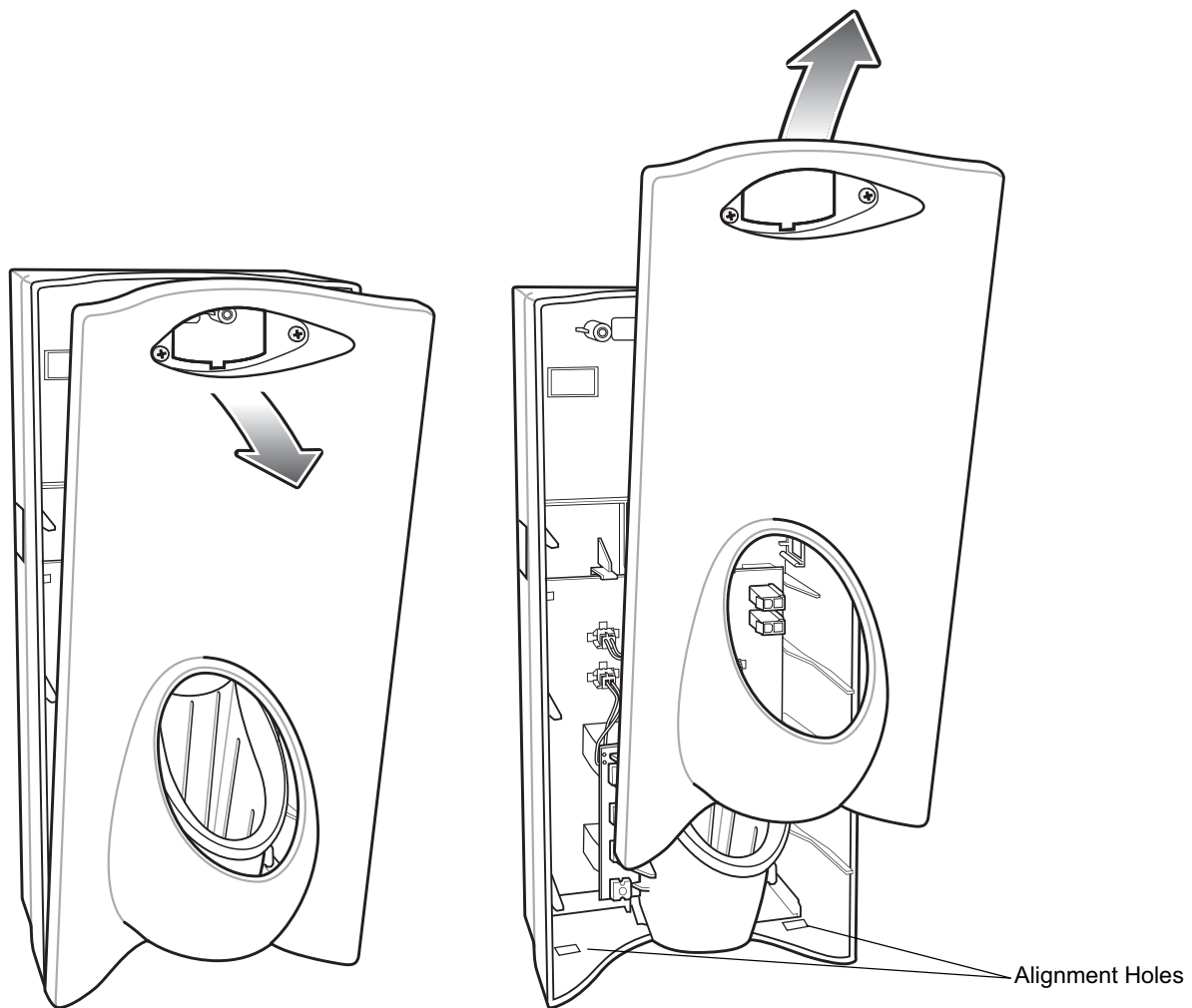

**Figure 8-2** Cover Removal

## Mounting the Cradle

The charge cradle contains mounting holes in the back housing so that it can be bolted to supporting furniture. In addition, it comes with plugs and a variety of cable routing outlets. Cable outlets not used can be concealed with the plugs provided. [Figure 8-3](#) provide the information required to design correct mounting holes for the charge cradles.

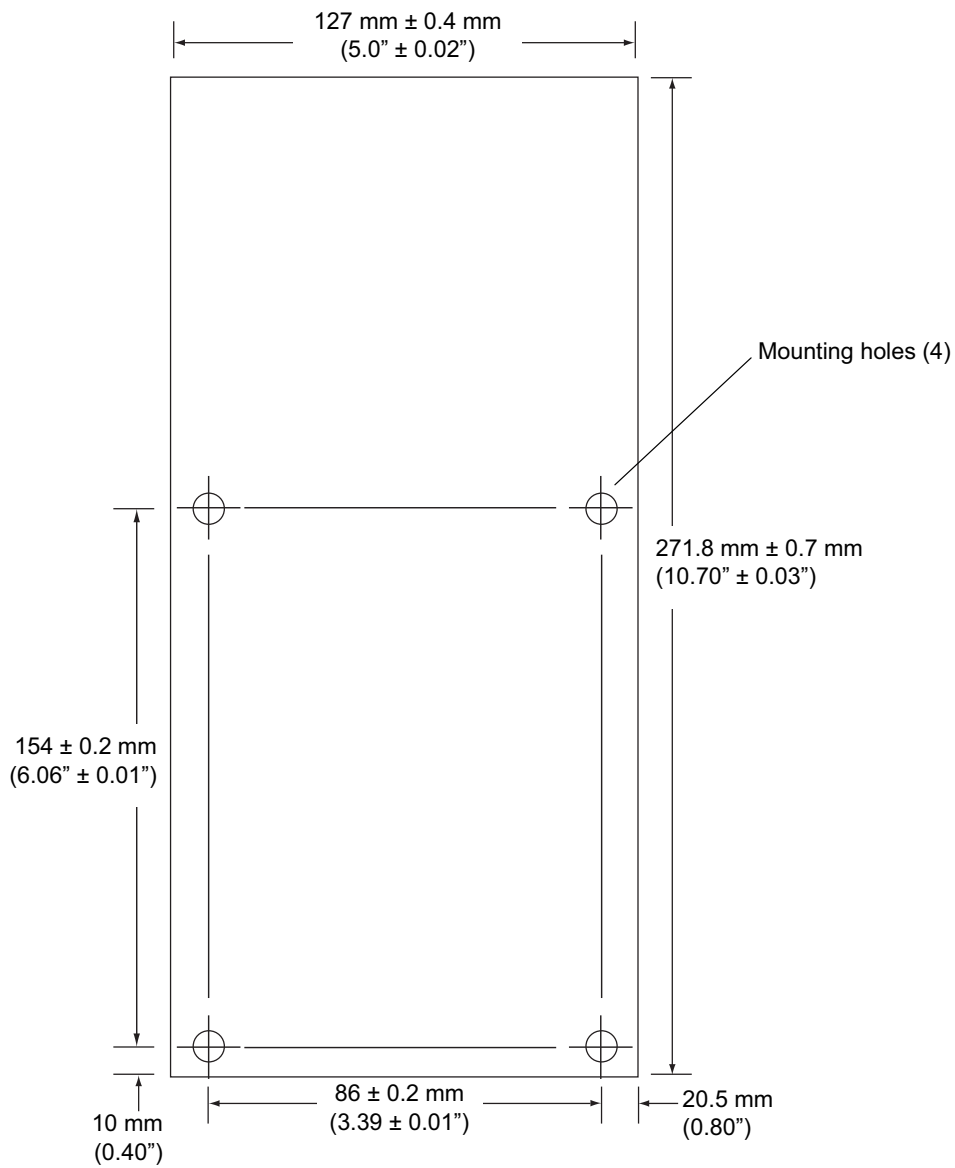

**Figure 8-3** Cradle Mounting Template

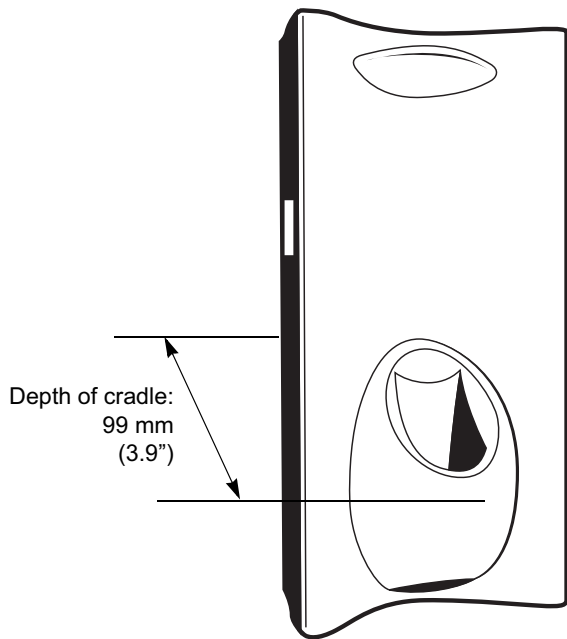

Figure 8-4 Overall Depth of Cradle

## Wiring

✓ **NOTE** During installation ensure all interconnect cables are fully enclosed within the power supply or cradle enclosure.

1. Install power supply, including AC line cord and power cable, into Decorative Housing.

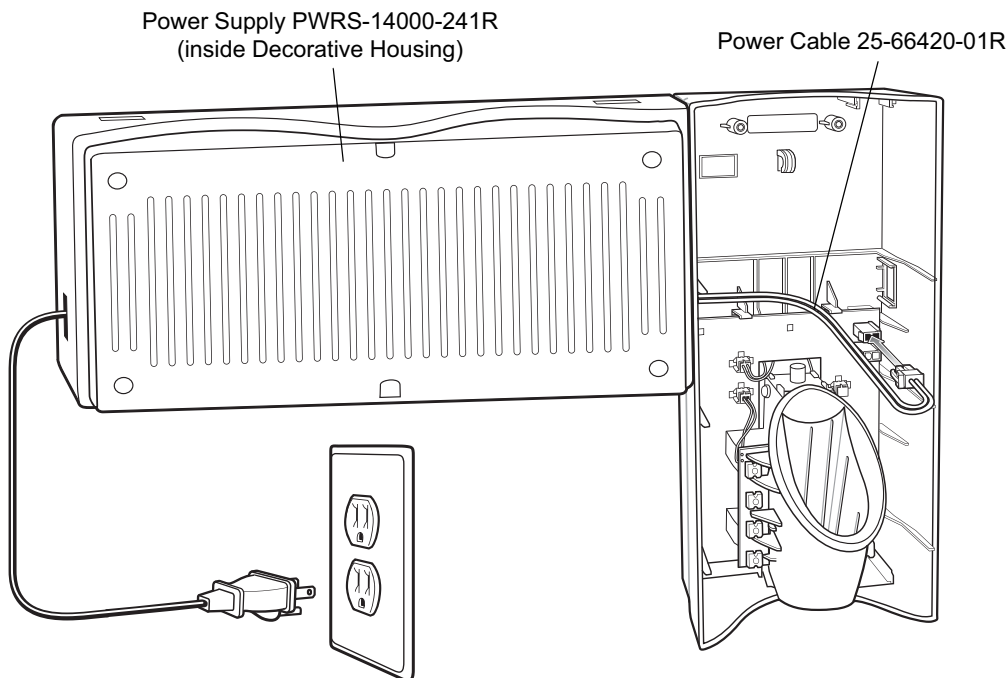
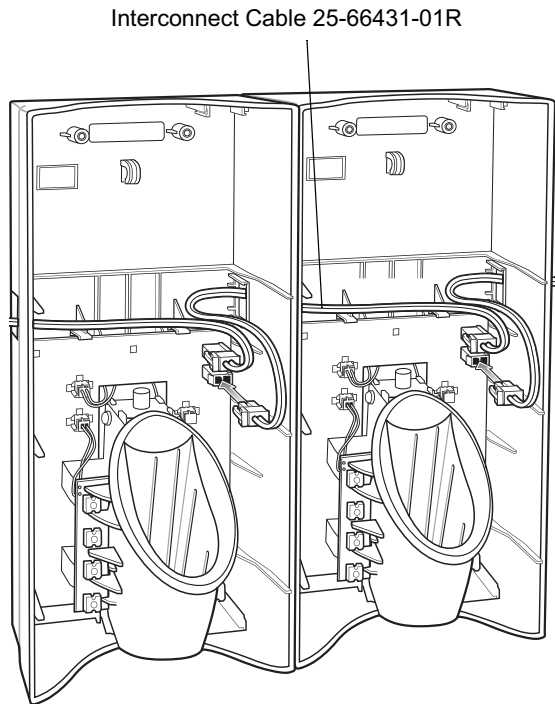

Figure 8-5 Connecting Power Supply

2. Insert power cable through a cable outlet of cradle back housing.
3. Plug connector into power connector on printed circuit board.
4. If more than one cradle, connect the interconnect cable from the first cradle to the second cradle.



**Figure 8-6** *Daisy-Chaining Cradles*

5. Use plugs to cover un-used cable outlets.

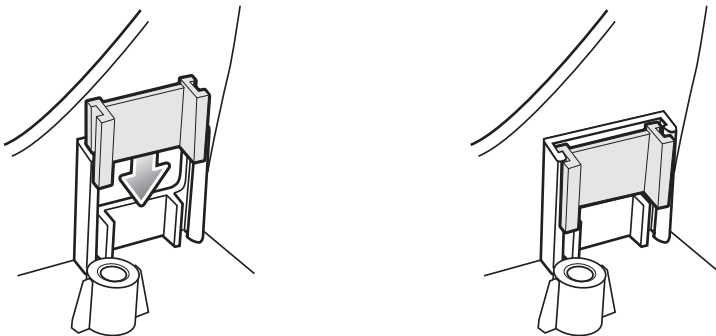

**Figure 8-7** *Cable Hole Plug Installation*

## Assembly

1. Replace cover.
2. Secure cover with screws.

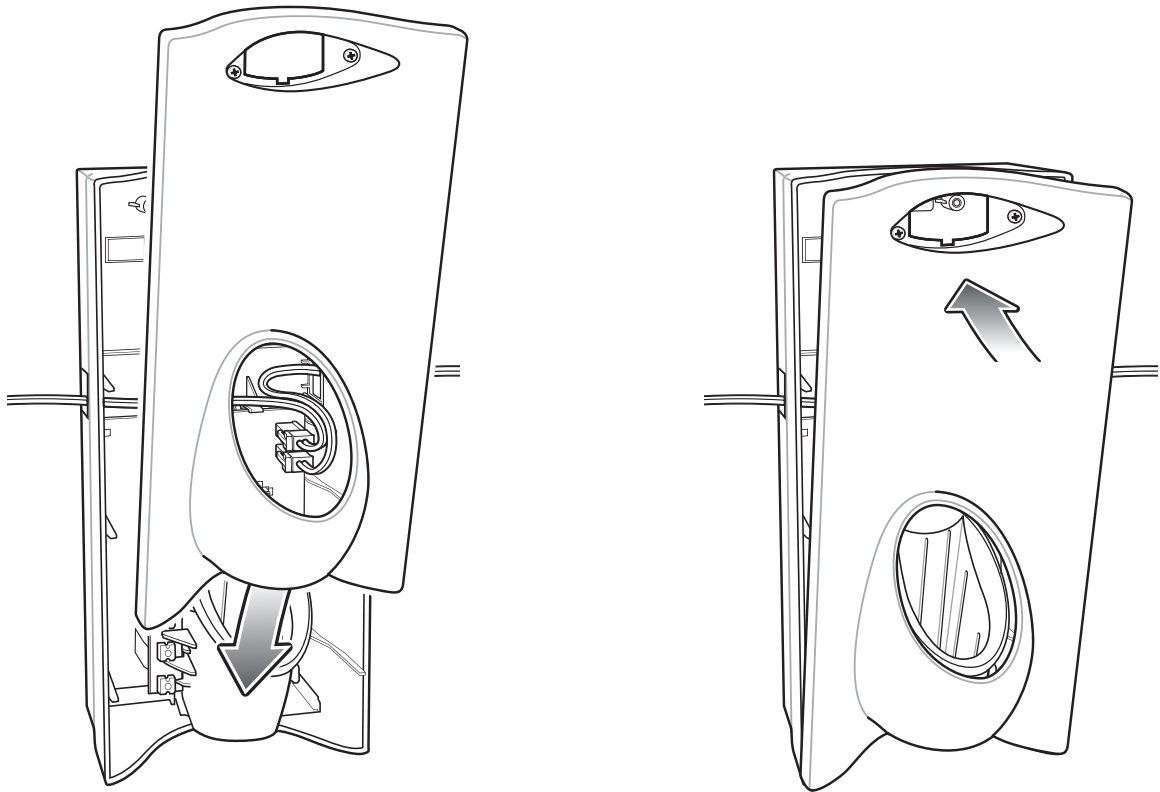

**Figure 8-8** *Replace Cover*

✓ **NOTE** Do not install the target cover until you are sure that you do not need to remove the front cover again.

3. Insert bar code target cover.
4. Push target cover into front cover until it snaps into place.

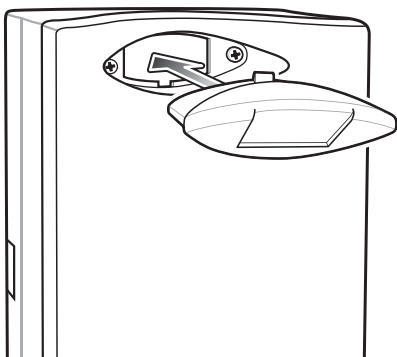

**Figure 8-9** *Replace Target Bar Code Cover*

## System Cabling

There are some general limitations that must be taken into account when designing a dispenser and ordering hardware elements of a system:

- No more than six cradles can be powered off of one power supply and power cable 25-66420-01R.
- No more than 12 cradles can be powered off of one power supply and “Y” power cable 25-67592-01R.
- No more than six cradles can be powered off each leg of the “Y” power cable.
- A power supply cable runs from the power supply to one or two cradles.
- Cradle interconnection cables run between each successive cradle in the chain.
- The power supply is air cooled, and as such expects some circulation of fresh air around it. Do not enclose it in a small airtight enclosure.
- Power supplies must be mounted in their natural, landscape orientation. They contain fans and their vents must allow for the free flow of air.
- Power supplies should be mounted either above or below dispensers and entrance heads. Mounting of power supplies to the right or left is not preferred.
- When laying out furniture, cable routing should be as direct as possible. Routing should follow vertical and horizontal runs through the modules. As part of each power supply that is shipped is a set of labels numbered 1 through 12. These labels are to be used to track the number of loads on a particular supply. Each label is affixed to the cradle interconnection cable when a cradle is added to the daisy chain. When all labels are used, the supply is fully loaded.

*Figure 8-10* shows how the maximum number of cradles can be cabled to a power supply using power cable 25-66420-01R.

*Figure 8-11* shows how the maximum number of cradles can be cabled to a power supply using the “Y” power cable 25-67592-01R. Note that there are only six cradles per leg of the power supply cable, and only 12 cradles in total.

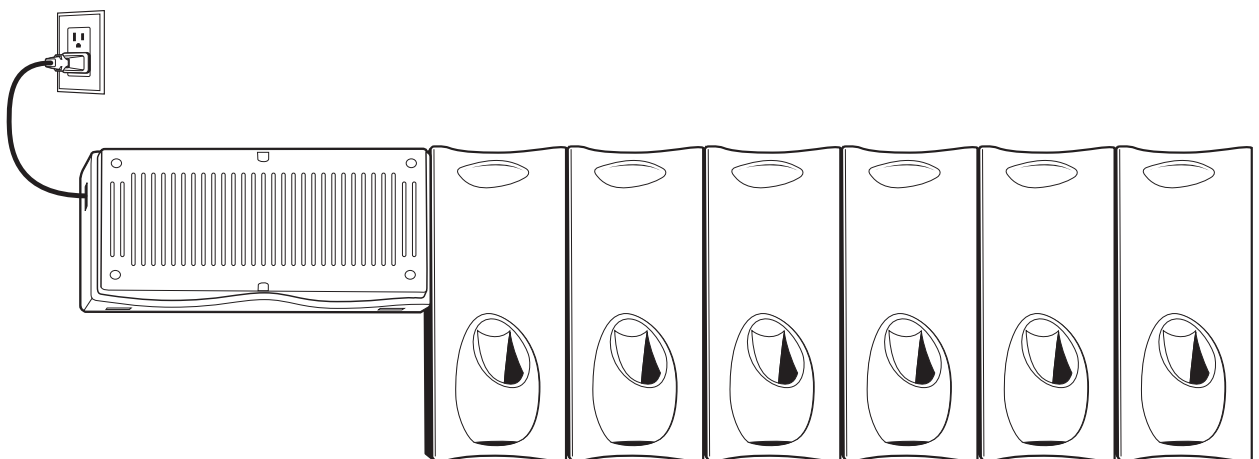

**Figure 8-10** Maximum Number of Charge Cradles per Power Supply

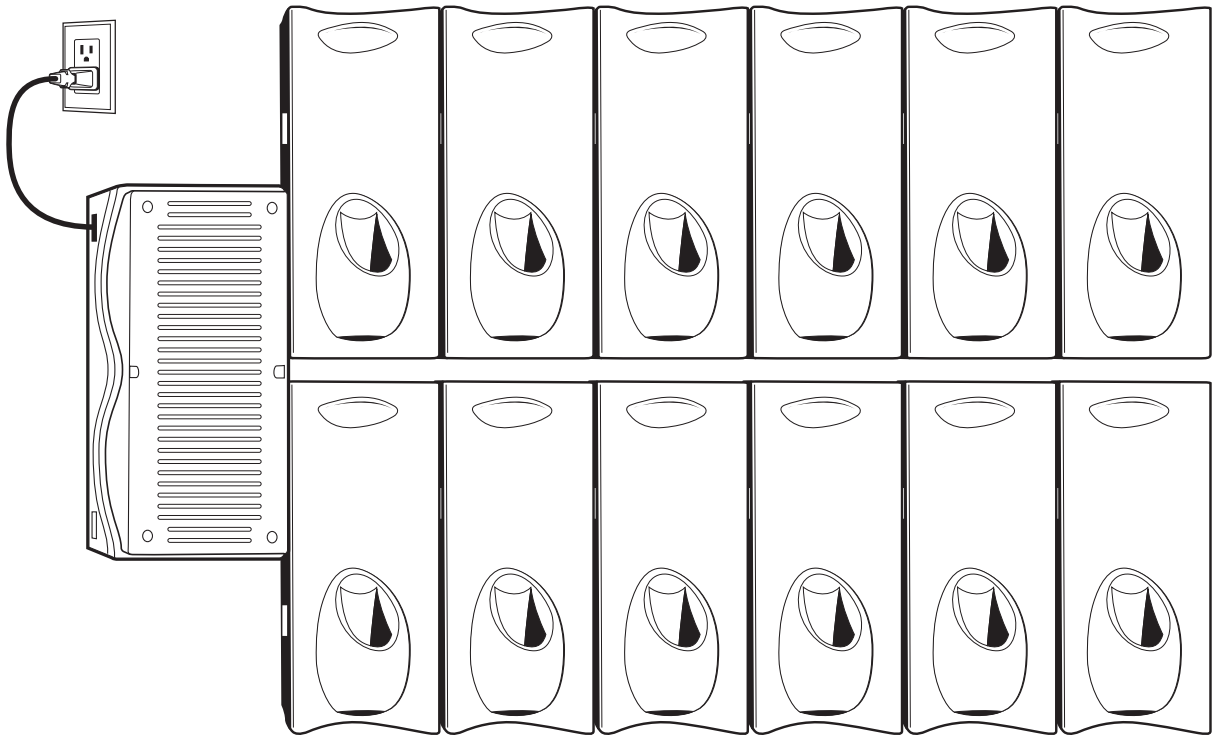

**Figure 8-11** Maximum Number of Charge Cradles per Power Supply with “Y” Power Cable



---

## Installation of the Three Slot Cradle

Installation of the three slot cradle include the following mounting steps:

- Selecting the mounting configuration (see [Mounting Configurations on page 8-9](#))
- Selecting the charging mode (see [Charging Modes on page 8-11](#))
- Mounting the power supply unit (see [Mounting the Power Supply Unit on page 8-19](#))
- Setting the cradle(s) (see [Setting and Controlling the Cradle on page 6-9](#))

---

## Mounting Configurations

Three slot cradles can be installed in the following mounting configurations:

- High Density (HD) configuration - Using HD cradles
- Super High Density (SHD) configuration - Using SHD cradles
- Desktop configuration - Using stand alone cradle(s) on a flat surface

### High Density Configuration

The cradle can be installed in high density configuration so that the display of the MC18 units is facing the user. In such configuration, cradles are installed in a vertical gap of 35mm between each other.

- ✓ **NOTE** In high density configuration, the MC18 units have 10 Degrees forward-facing tilt that should be taken in consideration if furniture is planned to be placed in front of the dispenser wall.

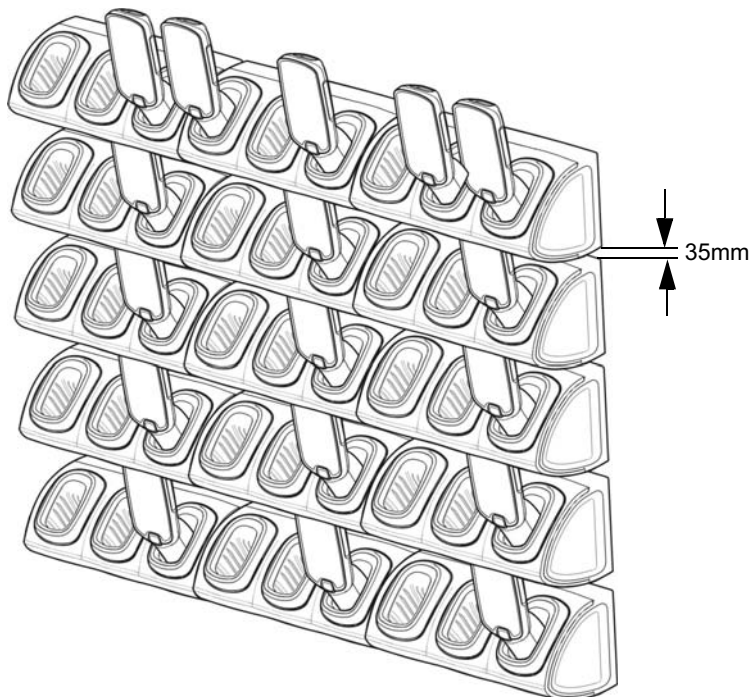

**Figure 8-12** Installation in High Density Configuration

The installation of the dispenser wall can be design so that it tilts backward slightly in the following angles:

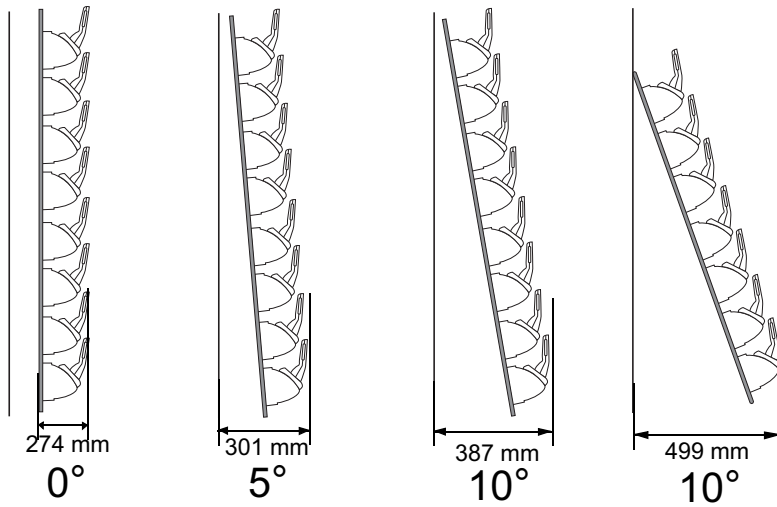

**Figure 8-13** *Dispenser Wall Angles*

### Super High Density Configuration

The cradle can be installed in super high density configuration so that the display of the MC18 units is facing up. In such configuration, cradles are installed with vertical gap of 7mm from each other to allow more cradles per given area.

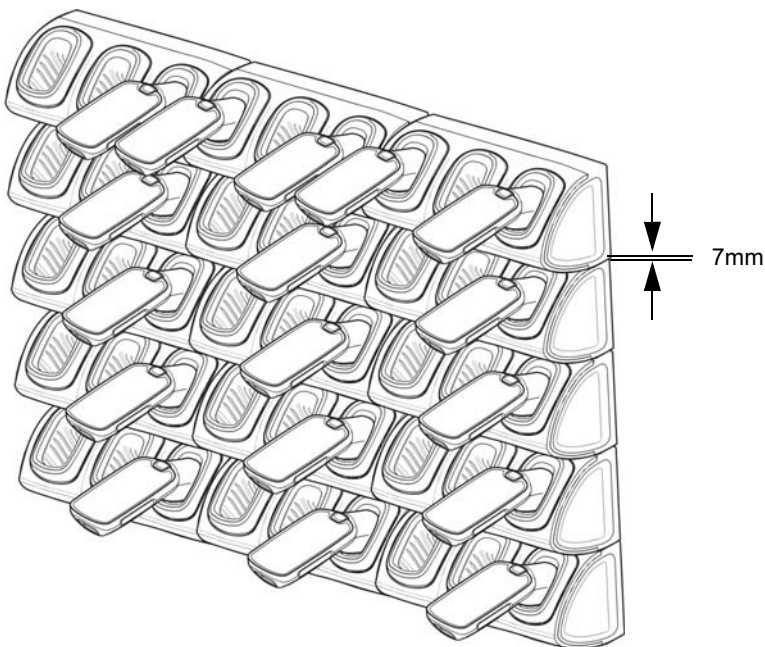

**Figure 8-14** *Installation in Super High Density Configuration*

## Desktop Configuration

In desktop configuration, the cradle can be placed on a flat tabletop or shelf in checkout locations or back room locations.

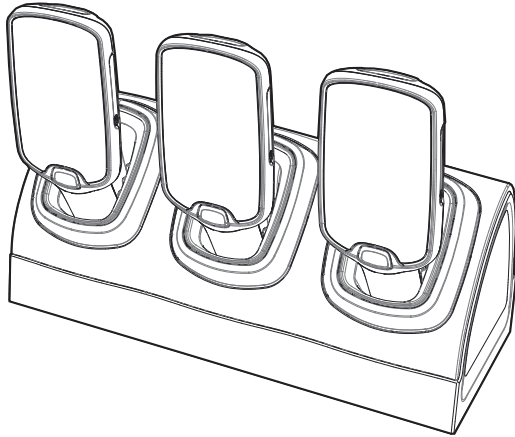

**Figure 8-15** *Installation in Desktop Configuration*

---

## Charging Modes

Three slot cradles can be installed in the following charging modes:

- Standard charging
- Fast charging

There are some general charging considerations that must be taken into account when designing a dispenser and ordering hardware elements of a system:

### Standard Charging Mode

- In standard charging mode, no more than four cradles can be powered off of one power supply unit (p/n PWRS-14000-241R) using “Y” power cable (p/n 25-67592-01R or p/n 25-66210-01R), power extension cables (p/n CBL-MC18-EXINT1-01) and interconnect cables (p/n 25-66431-01R).
- In standard charging mode, the current draw by each docked MC18 can reach a maximum of 1A.
- Cable routing should be as direct as possible. Routing should follow vertical and horizontal runs through the modules.

Figure 8-16 shows how the four cradles can be cabled to a power supply unit in standard charging mode.

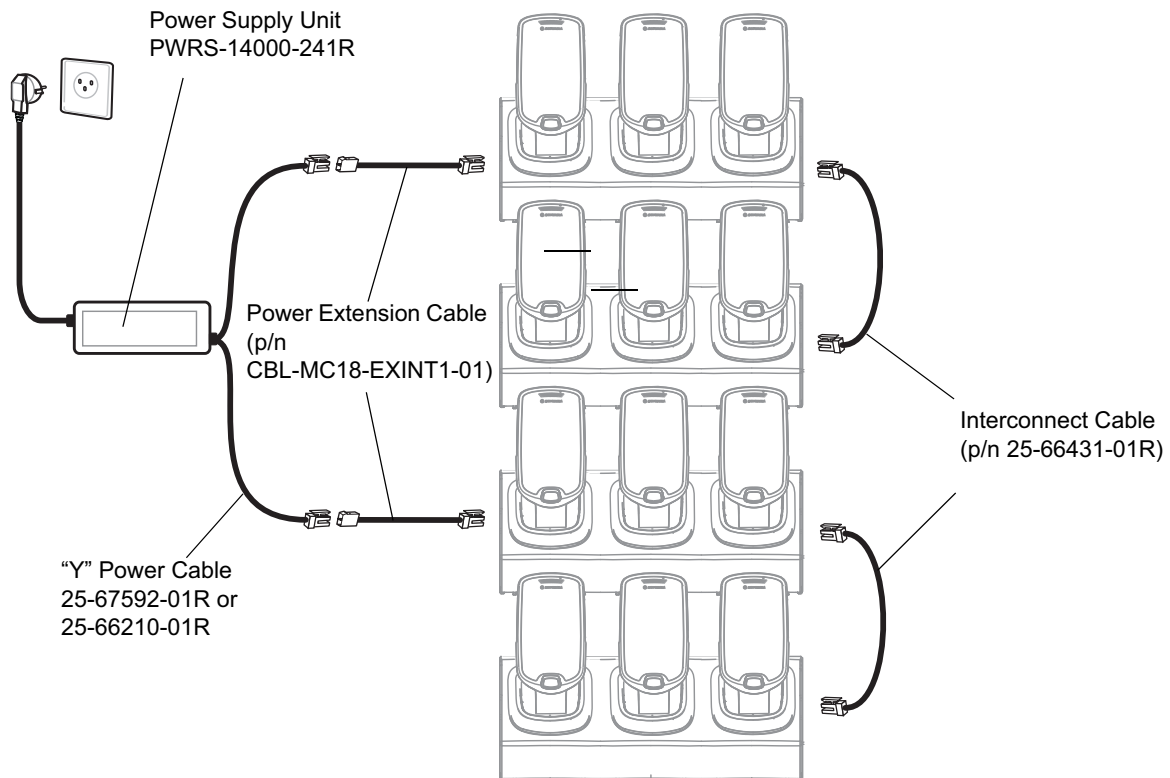
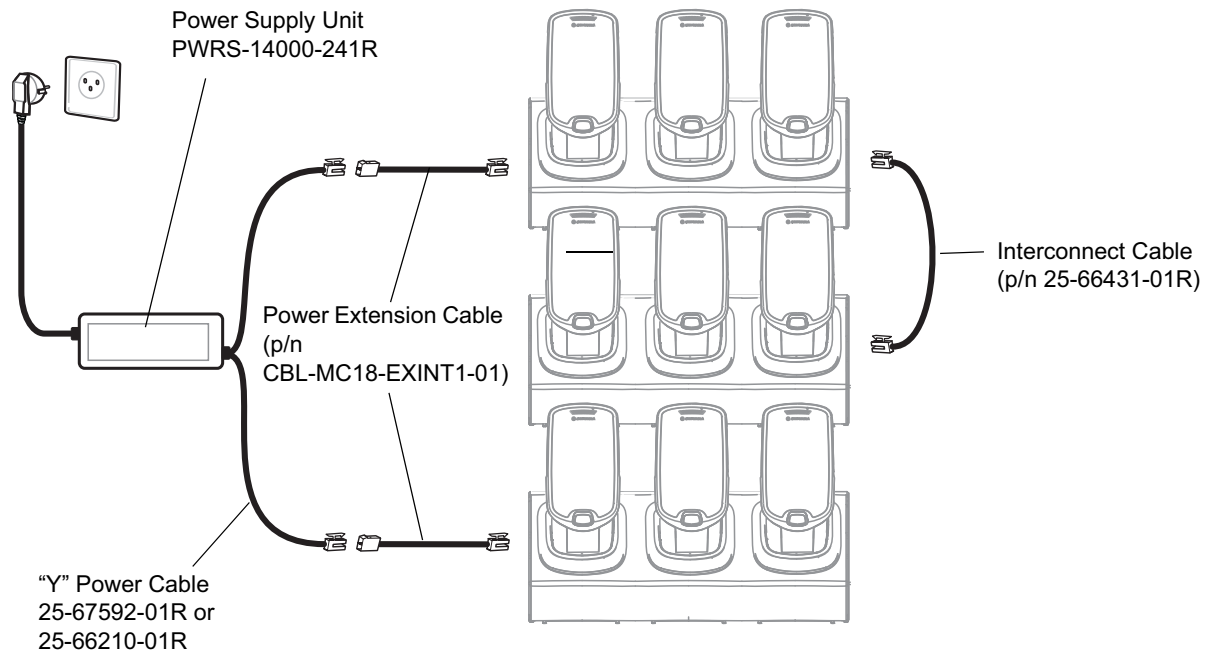

Figure 8-16 Standard Charging Mode - Cable Connections

### Fast Charging Mode

- In fast charging mode, no more than three cradles can be powered off of one power supply unit (p/n PWRS-14000-241R) using "Y" power cable (p/n 25-67592-01R or p/n 25-66210-01R), power extension cables (p/n CBL-MC18-EXINT1-01) and interconnect cable (p/n 25-66431-01R).
- In fast charging mode, the current draw by each docked MC18 can reach a maximum of 1.5A.
- Cable routing should be as direct as possible. Routing should follow vertical and horizontal runs through the modules.

Figure 8-17 shows how the three cradles can be cabled to a power supply unit in fast charging mode.



**Figure 8-17** *Fast Charging Mode Cable Connections*

### Mounting the Three Slot Cradle on a Dispenser Wall

The cradle can be bolted to a dispenser wall or any supporting furniture using eight mounting holes. The back cover of the cradle has two access holes for routing power cables to \ from a power supply unit or adjacent cradle. *Figure 8-18* provides a mounting template for cradle installation.

Perform this procedure to mount the cradle on a dispenser wall:

- ✓ **CAUTION** DO NOT connect more than four cradles to a single power supply unit.  
DO NOT connect the power supply unit to power outlet until all installation steps are completed.
- ✓ **NOTE** The following procedure is an example installation of three slot cradles in fast charging mode - high density configuration.

1. Use the wall mount template to plan and mark the screw locations on the dispenser wall.

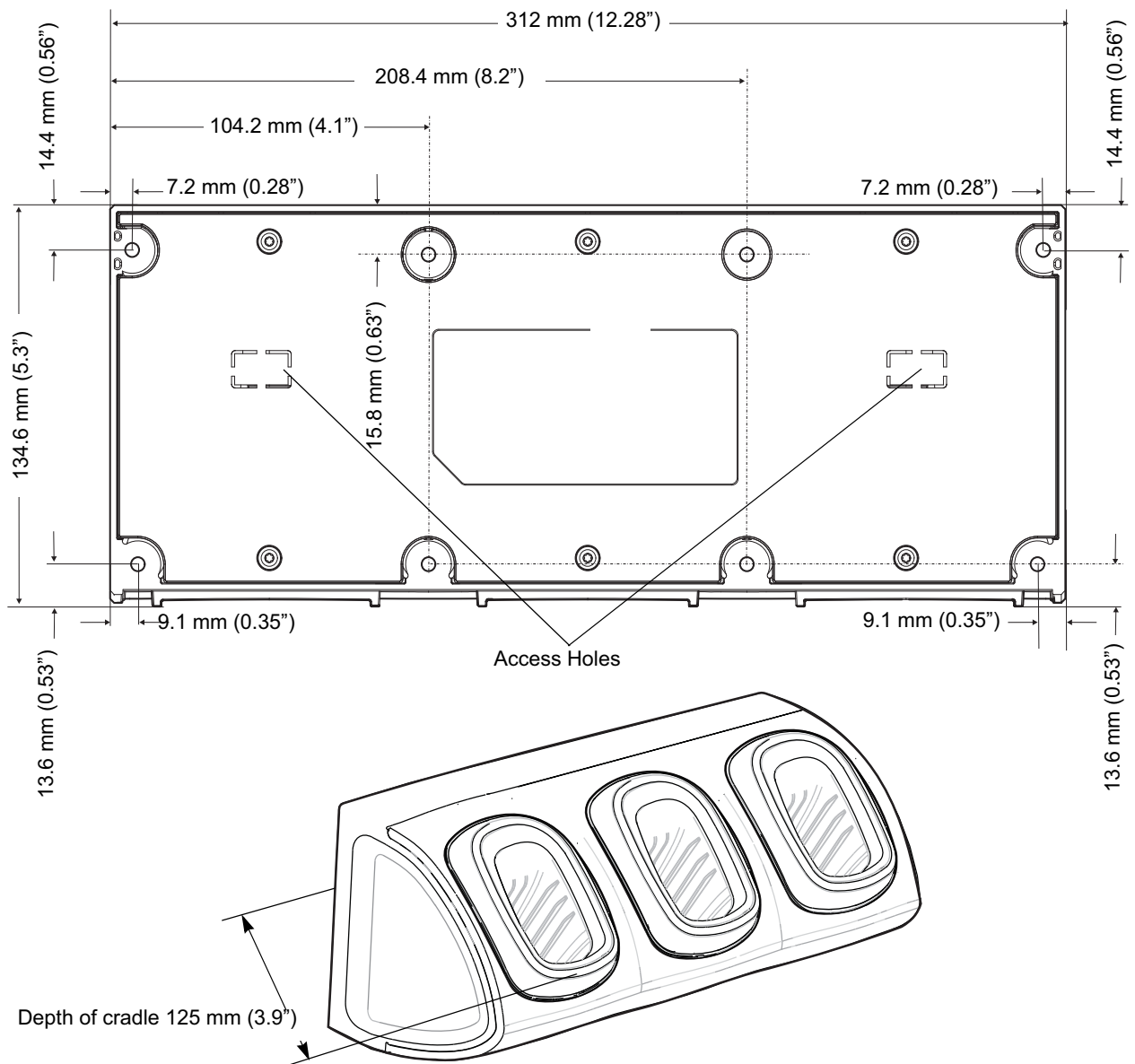

**Figure 8-18** Three Slot Cradle - Mounting Template and Overall Depth

2. In all cradles, plug the power extension cable (p/n CBL-MC18-EXINT1-01) to free the connector on left slot.
3. Plug interconnect cable (p/n 25-66431-01R) to free connector on right slot.

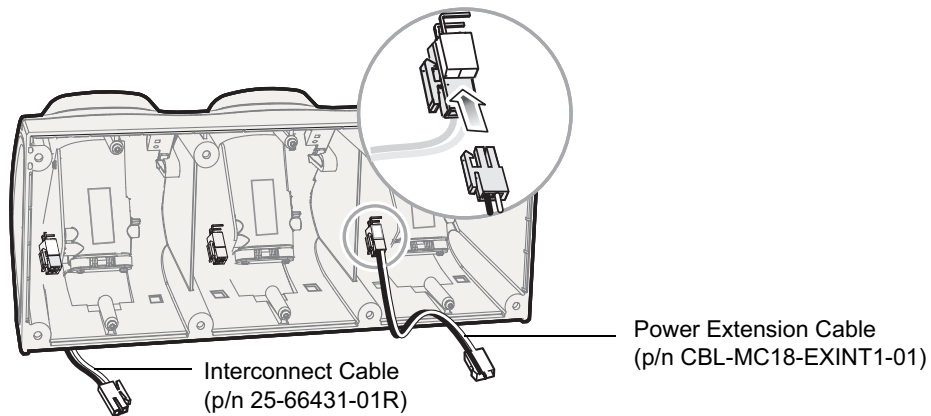

**Figure 8-19** Three Slot Cradle - Cable Connections

4. On all the back covers, knock-out the stamped access hole(s).

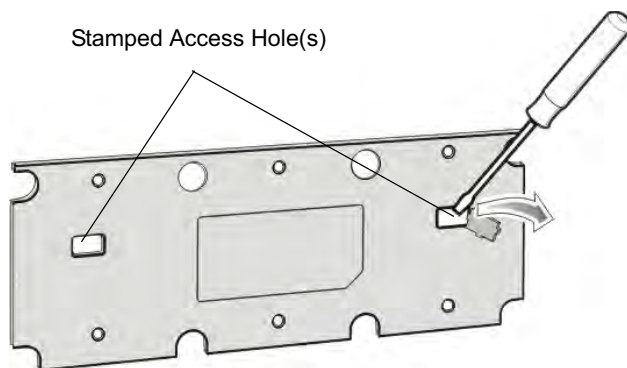

**Figure 8-20** Three Slot Cradle - Stamped Access Hole(s)

5. Route interconnect cables through access holes in back covers.

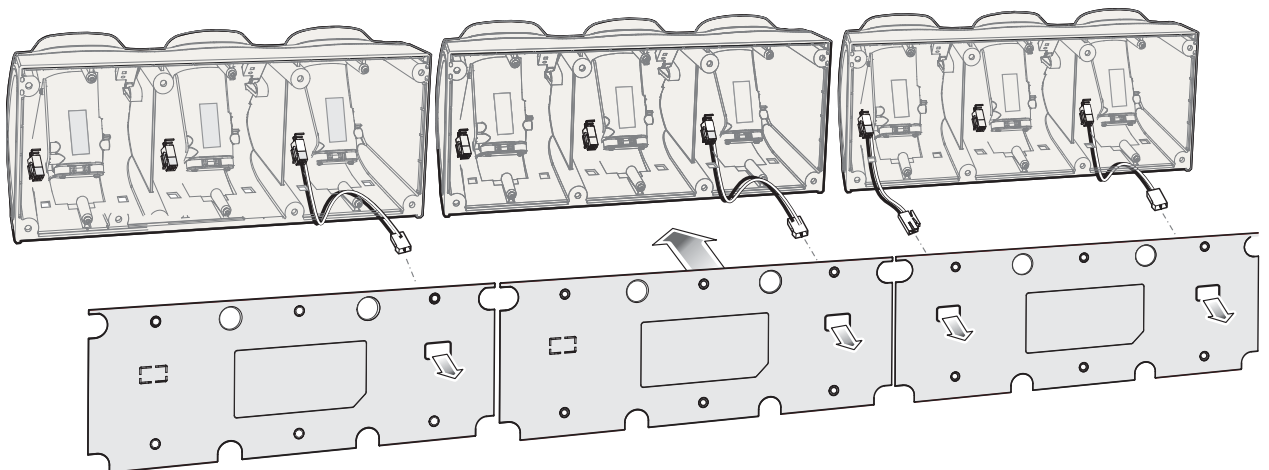

**Figure 8-21** Three Slot Cradle - Back Cover Cable Routs

- Secure the back covers to cradles using six T10 Torx screws (supplied) Torque screws to 6 Kgf-cm (5.2 in-lb).

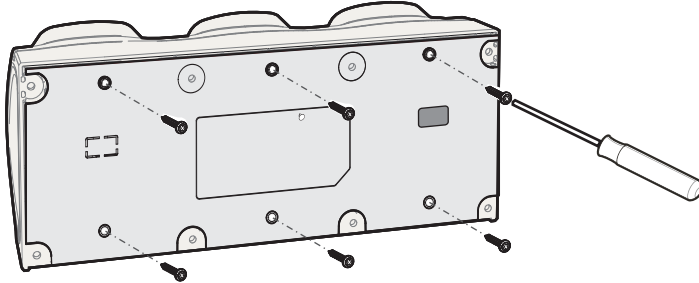

**Figure 8-22** Three Slot Cradle - Securing the Back Cover

- Insert the front cover removal tool into two slots, lever upwards and pull to remove front cover from cradle.

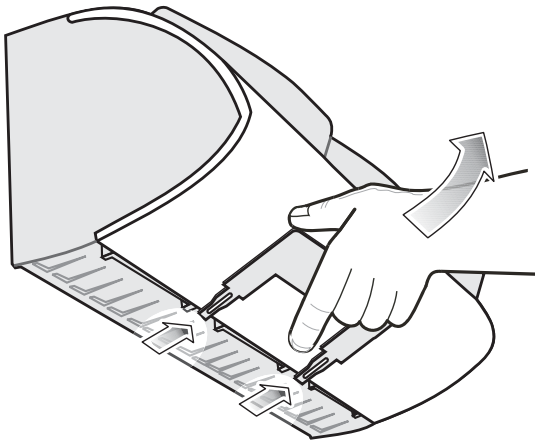

**Figure 8-23** Three Slot Cradle - Removing Front Cover

- Position the cradle on the dispenser wall and route all interconnect cables through the access holes in the dispenser wall.
- Fasten the cradle to the wall using eight screws (not supplied). Ensure to use additional wall mounting hardware, as needed, for safe mounting according to the wall type.

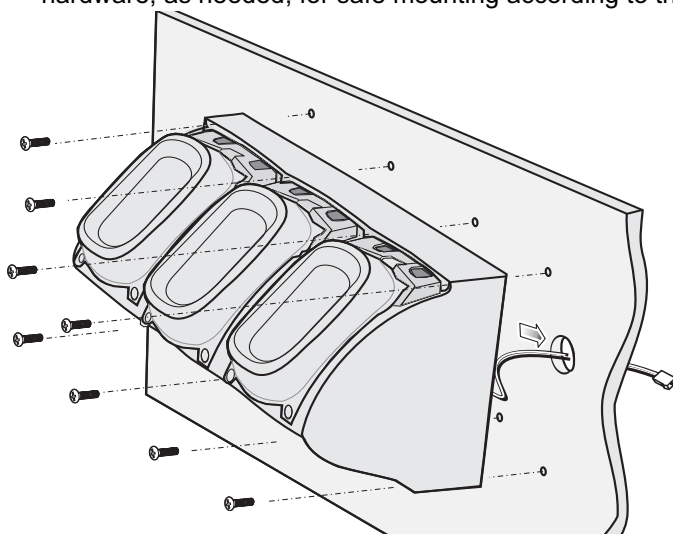

**Figure 8-24** Three Slot Cradle - Fastening the Cradle to a Wall



10. Insert tabs on upper side of front cover into slots on cradle and rotate cover down until it snaps into place.

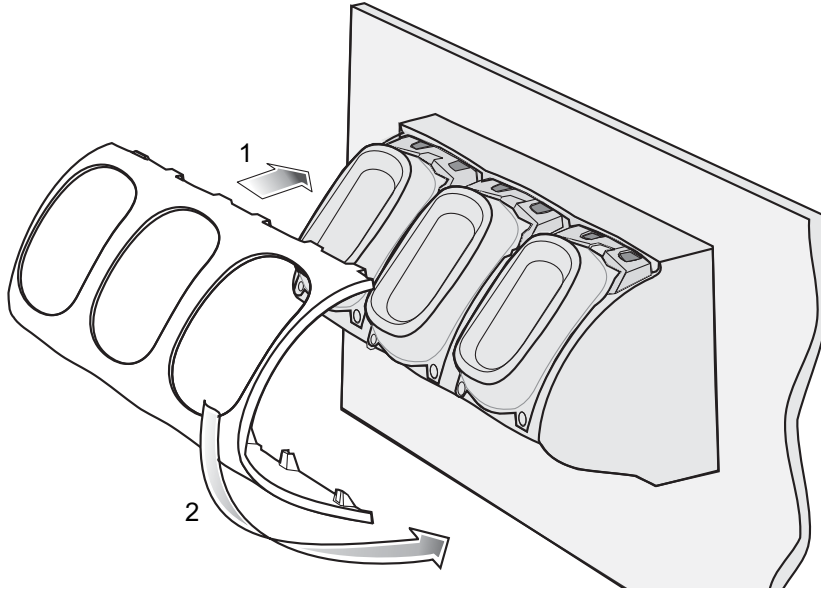

**Figure 8-25** *Three Slot Cradle - Connecting the Front Cover*

11. Plug Power Extension Cable (p/n CBL-MC18-EXINT1-01) to interconnect cable (p/n 25-66431-01R).
12. Plug "Y" cable (25-67592-01R) to Interconnect cables (p/n 25-66431-01R).
13. Plug "Y" cable (25-67592-01R) to power supply unit.
14. Secure power supply unit (p/n PWRS-14000-241R) to the back of the dispenser wall.

15. Connect the power cord to the power supply unit and to a 110/220 VAC outlet.

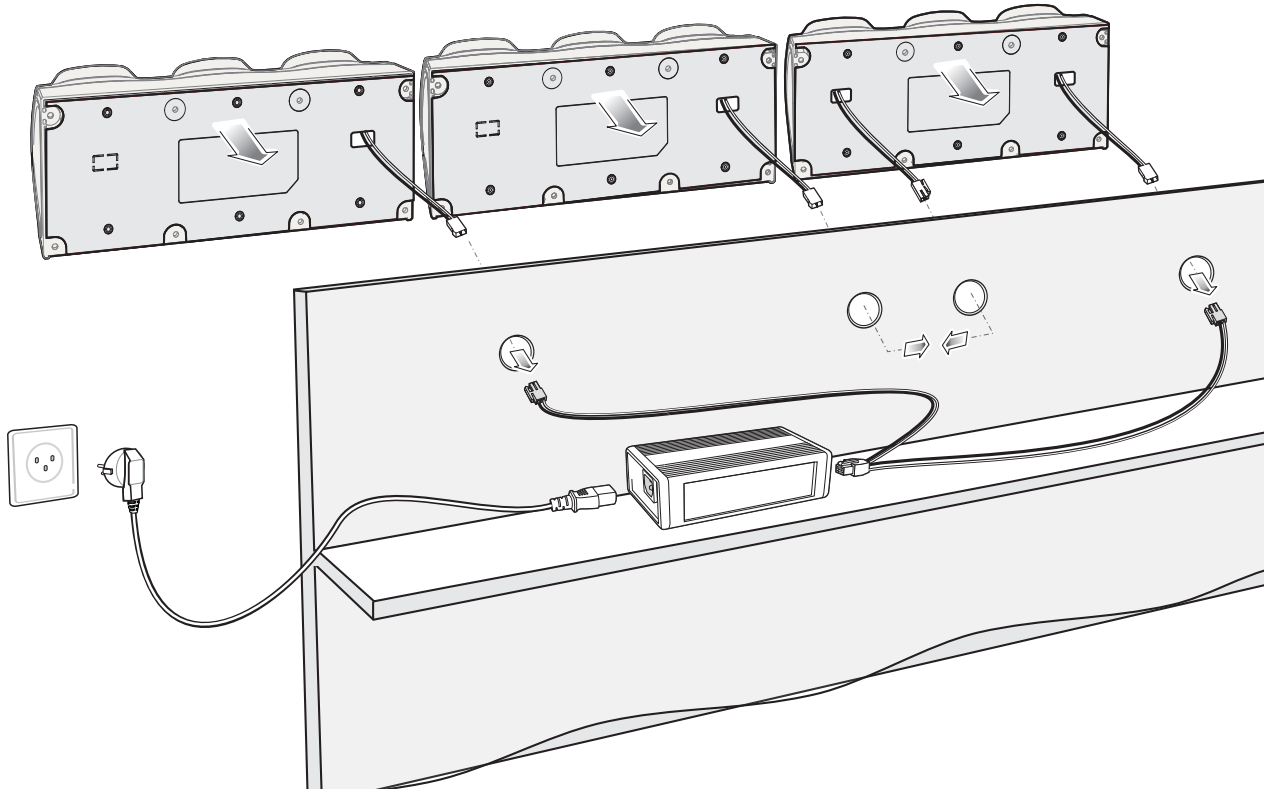

**Figure 8-26** *Three Slot Cradle - Connection to Power Supply Unit*

16. Place the socket onto the cradle and secure the four screws.
17. Place the socket cover onto the cradle and secure the two screws.

## Mounting the Power Supply Unit

- ✓ **NOTE** The power supply unit should be mounted in landscape orientation. Power supplies must be mounted in their natural, landscape orientation. They contain fans and their vents must allow for the free flow of air.

- ✓ **IMPORTANT** The power supply unit is air cooled and requires circulation of free air around it. Do not enclose it in a small airtight enclosure other than plastic housing, p/n PSS-3PS04-00R.

The power supply can be housed in an optional plastic housing, p/n PSS-3PS04-00R, to match the cradles and hide bare power supplies and cables. This section provides the information required to mount the plastic housing

To install the power supply unit inside the plastic housing:

1. Use the mounting template of the power supply housing to plan and mark the screw locations on the dispenser wall.

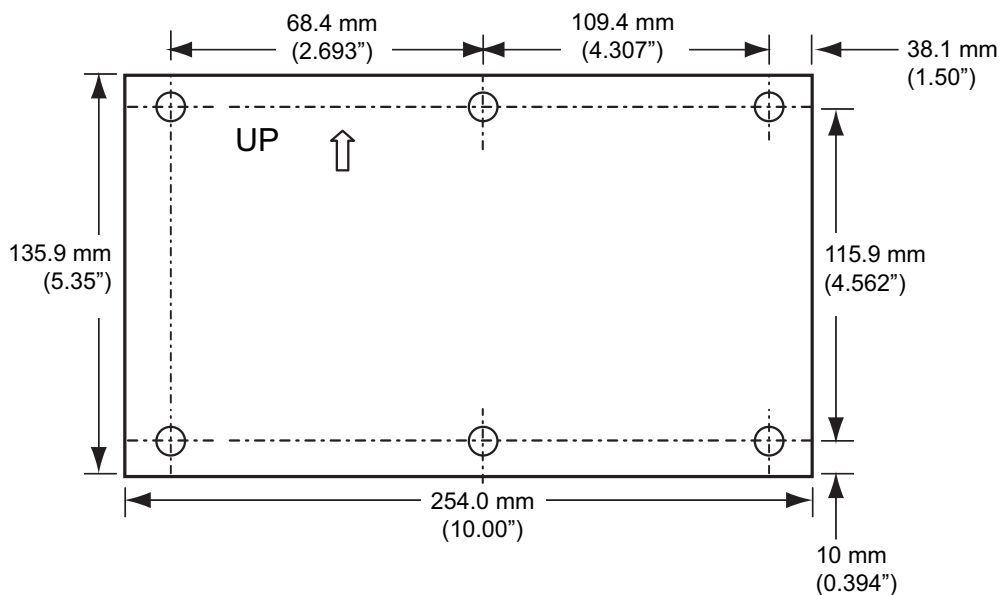

(View from Inside Housing)

The depth of the fully-assembled power supply decorative housing is 81.23 mm (3.198").

**Figure 8-27** Power Supply Housing Mounting Template

2. Feed cables through access holes in bottom housing.
3. Plug connectors into power supply.
4. Place power supply into bottom housing.
5. Place two mounting brackets over power supply and secure each mounting bracket with two screws.

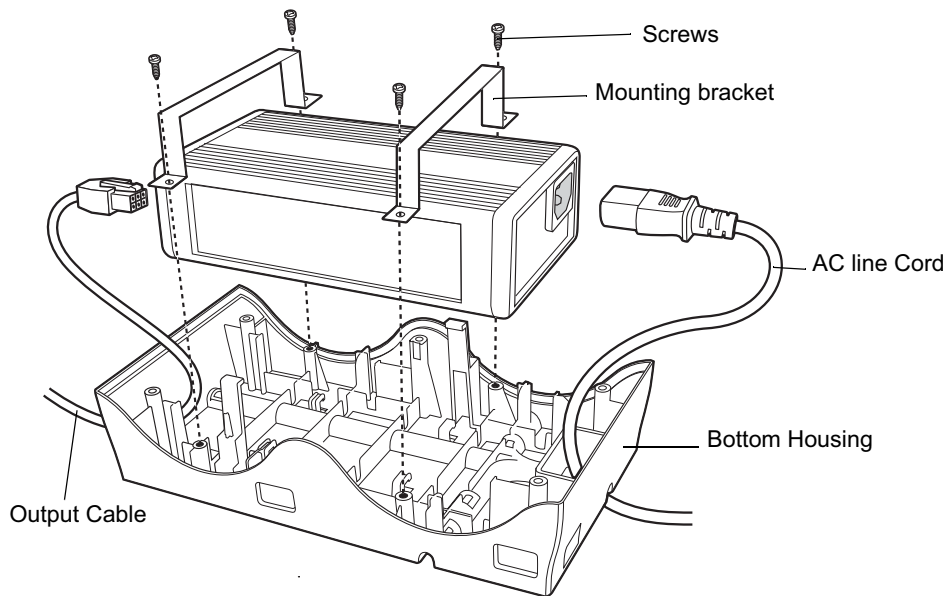

**Figure 8-28** Power Supply Assembly

6. Align top housing over bottom housing and secure using six screws.

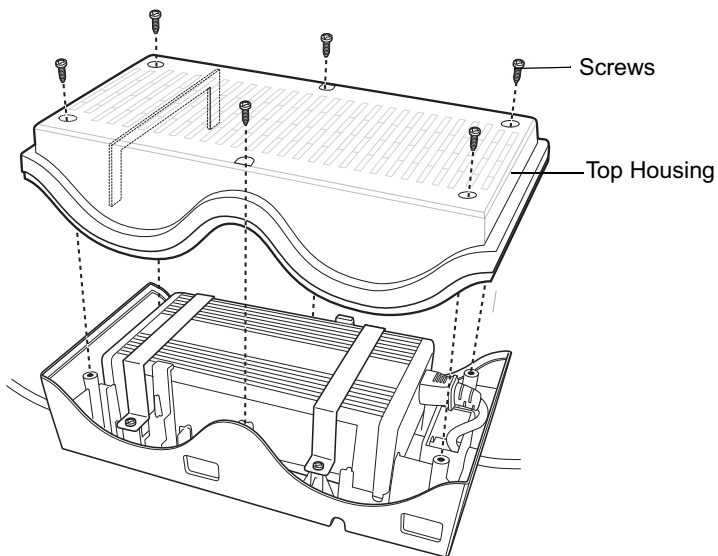

**Figure 8-29** Top Housing Installation

# CHAPTER 9 APPLICATION DEPLOYMENT

---

## Software Installation on Development PC

To develop applications to run on the MC18, use one or all of the following:

- Microsoft Visual Studio 2005/2008
- Enterprise\_Mobility Developer Kit (EMDK) for C/C++
- Enterprise Mobility Developer Kit (EMDK) for .NET
- Enterprise Mobility Developer Kit (EMDK) for Pocket Browser
- Windows CE Platform PSDK for MC18No
- Active Sync v4.5/ WMDC v6.1
- Device Configuration Package (DCP) for 8 v99.45.00xx.

Refer to the *Developer Guide*, p/n 72E-71161-xx, for detailed information on the EMDKs.

The Windows CE Platform SDK for the MC18xxc50 is used in conjunction with the EMDK for C to create Windows CE applications for the MC18. The Platform SDK installs a new Windows CE device type and its associated libraries onto the development PC.

The Device Configuration Package (DCP) is required to create and download hex images that represent flash partitions to the MC18. The DCP includes the user documentation, flash partitions, Terminal Configuration Manager (TCM) and the associated TCM scripts.

## Device Configuration Package

Use this procedure to install the DCP for MC18xxc50:

1. Download the DCP from the Support Central web site, <http://www.motorolasolutions.com/support>:
  - a. On <http://www.motorolasolutions.com/support>, select *Software Downloads*.
  - b. Select *Mobile Computers* and then select *MC18*.
  - c. Select the *Device Configuration Package (DCP)*.
  - d. Save the .exe file to the development computer.

2. Locate the .exe file on the development computer, double-click the file, and follow the install screen prompts.
3. Once installed, access the major components of the DCP from the *Symbol Device Configuration Package (DCP)* for MC18xxc50 program group of the *Windows Start Menu*.

## Platform SDK

Different Platform SDKs are required for the Microsoft® Windows CE 7.0 Professional Core platforms.

Use this procedure to download and install the appropriate Platform SDK:

1. Download the appropriate Platform SDK from the Support Central web site, <http://www.motorolasolutions.com/support>:
  - a. On <http://www.motorolasolutions.com/support> select *Software Downloads*.
  - b. Select *Mobile Computers* and then select *MC18*.
  - c. Select the *Platform SDK*.
  - d. Save the .exe file to the development computer.
2. Run the file and follow the screen prompts to install.

## Enterprise Mobility Developer Kits

Use this procedure to install an EMDK:

1. Download the EMDK from the Support Central web site, <http://www.motorolasolutions.com/support>:
  - a. On <http://www.motorolasolutions.com/support>, select *Developer Downloads* and sign in.
  - b. Select *Mobile Computers* and then select *MC18*.
  - c. Select the latest version of the *Enterprise Mobility Developer Kit*.
  - d. Download the .exe file to the development computer.
2. Double-click the executable file and follow the install screen prompts.

## Installing Other Development Software

Developing applications for the MC18 may require installing other development software such as application development environments on the development PC. Follow the installation instructions provided with this software.

## Deployment

With the appropriate accessory, software, and connection, the MC18 can share information with the host device. This section provides information about installing software and files on the MC18.

Download/install software using:

- ActiveSync / Windows Mobile Device Center
- IPL.

## ActiveSync

Use ActiveSync or Windows Mobile Device Center to copy files from a host computer to the MC18.

1. Ensure that ActiveSync or Windows Mobile Device Center is installed and that a partnership has been created, see [Chapter 4, Sync with Host Computer](#).
2. Connect the MC18 to the host computer using the cradle, see [Connecting the MC18 to a Host Computer on page 4-2](#) for connection information.
3. On the host computer, select **Start > All Programs > ActiveSync** (or **Windows Mobile Device Center**).
4. Select **Explore** (or **File Management**).

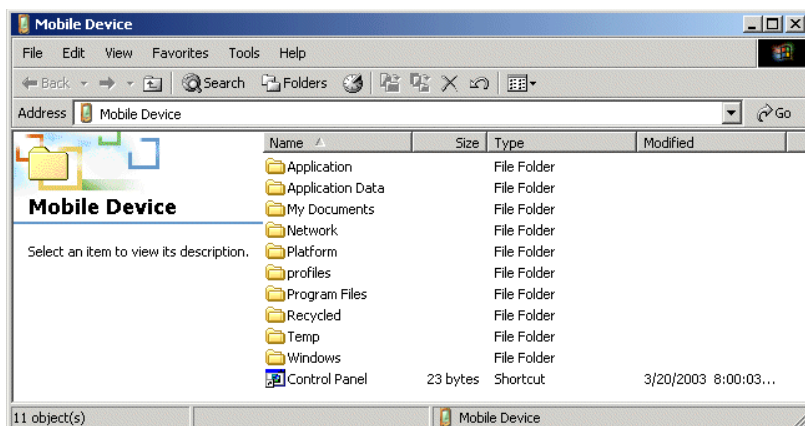
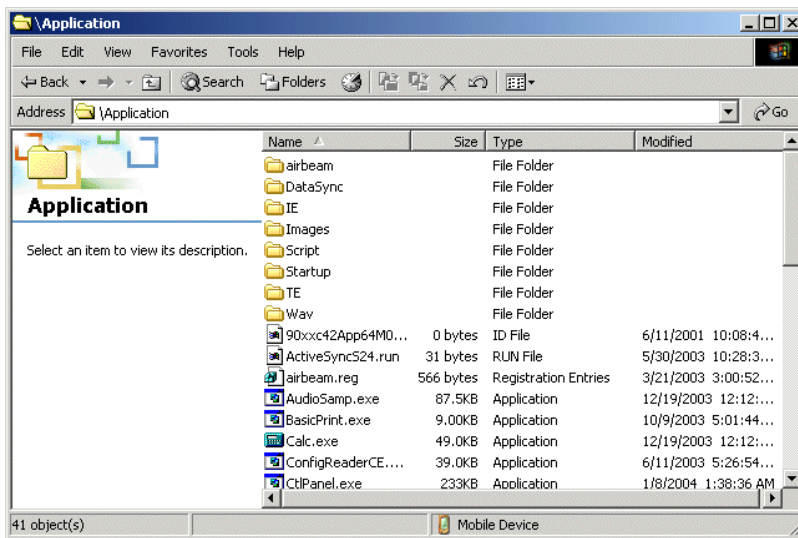

Figure 9-1 ActiveSync Explorer

5. Double-click the folder to expand the contents of the folder.



**Figure 9-2** My Pocket PC Contents

6. Use Explorer to locate the host computer directory that contains the file to download. Touch that directory in the left pane to display its contents in the right pane.
7. Drag the desired file(s) from the host computer to the desired mobile device folder.
  - *Program Files* folder: files stored in this folder are discarded after a cold boot.
  - *Application* folder: files stored in this folder are retained after a cold boot.

## IPL

Use IPL to download files onto the MC18, to download customized flash file system partitions to the MC18 and load hex files to the flash memory of the MC18.

There are two types of updates supported by the MC18: partitions and files. The file system used by the MC18 is the same as the file system used on a desktop computer. A file is a unit of data that can be accessed using a file name and a location in the file system. When a file is replaced, only the contents of the previous file are erased. The operating system must be running for a file to be updated, so the IPL cannot perform individual file updates as it is a stand-alone program that does not require the operating system to be running.

A typical partition is a group of files, combined into a single “partition” that represents a specific area of storage. Examples of partitions are the flash file systems such as *Platform* or *Application*. (Using the desktop computer comparison, these partitions are roughly equivalent to a C: or D: hard disk drive.) In addition to the “hard disk” partitions, some partitions are used for single items such as the operating system, monitor, or splash screen. (Again using a desktop computer comparison, these partitions are roughly the equivalent of the BIOS or special hidden system files.) When a partition is updated, all data that was previously in its storage region is erased - i.e. it is not a merge but rather a replacement operation. Typically, the operating system is not running when partitions are updated, so IPL can perform partition updates.

Partition images for selected partitions can be created by TCM. All partition images suitable for use by IPL are in hex file format for transfer by TCM from the development computer to the MC18.

Upgrade requirements:

- The hex files to be downloaded (on development computer)
- A connection from the host computer and the MC18 (either serial or wireless)



- TCM (on development computer) to download the files.

Once these requirements are satisfied, the MC18 can be upgraded by invoking IPL and navigating the menus.

## Updating Images

The MC18 contains tools that update all operating system components. All updates are distributed as packages and/or hex images. Update packages can contain either partial or complete updates for the operating system. Symbol Technologies distributes the update packages on the Support Central Web Site, <http://www.motorolasolutions.com/support>.

Update an operating system component using one of the following:

- OS Update
- BootLoader
- MSP

### OSUpdate Loader

Operating system component can be downloaded to the MC18 using the Temp folder.

### Using the Temp Folder

To initiate an update using the MC18 Temp folder:

1. Go to the Support Central web site, <http://www.motorolasolutions.com/support> and download the appropriate update package.
2. Connect the MC18 to a host computer using. See *Connecting the MC18 to a Host Computer on page 4-2*.
3. Select **Start > Settings > Control Panel**.
4. Select **System** icon.
5. Select **Memory** tab.



**Figure 9-3** System Properties - Memory Tab

6. Move the slider to the center position.

7. Select **OK**.
8. Using ActiveSync or Windows Mobile Device Center, copy the update package to the \Temp folder on the MC18.
9. On the MC18, use **Windows Explorer** and navigate to the \Temp folder.
10. Open the **OSUpdate** folder.
11. Select the file: 18X0c70Ben\_TEMP.
12. When the Update Loader application finds the appropriate file, it loads the package onto the MC18. A progress bar displays until the update completes.
13. When complete, the MC18 re-boots.

### Bootloader

Use Bootloader to download hex files to the MC18 from a host computer via USB.

### MC18

Use Bootloader to download customized flash file system partitions to the MC18 and load hex files to the flash memory of the MC18.

To load the hex files on to the MC18 using USB:

1. Download the USBDownload application from the Support Central web site. Follow the installation instructions with the application.
2. Connect the MC18 to a host computer using. See [Connecting the MC18 to a Host Computer on page 4-2](#).
3. On the host computer, launch the USBDownload application.

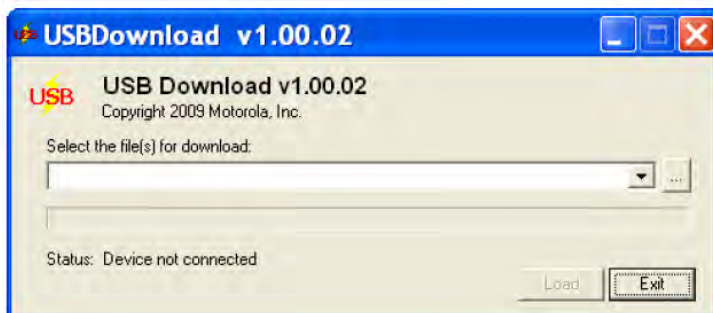

**Figure 9-4** USB Download Window

4. Simultaneously press the Power button and the 1 and 9 keys.

5. Immediately, as soon as the device starts to boot, press and hold the scan key. The Bootloader screen appears.

```
Select required operation
Download from SD card
Download from USB
Exit

Bootloader 1.02.0000
```

**Figure 9-5** *Bootloader Menu*

**CAUTION** To ensure a successful download, do not remove power from the MC18 while in Bootloader.

1. Use the scan key to select **Download from USB**.
2. The Bootloader displays the following:

```
Waiting for input. . .

Bootloader 1.02.0000
```

**Figure 9-6** *Waiting for Input*

**Figure 9-7** On the host computer, locate the hex files to download.

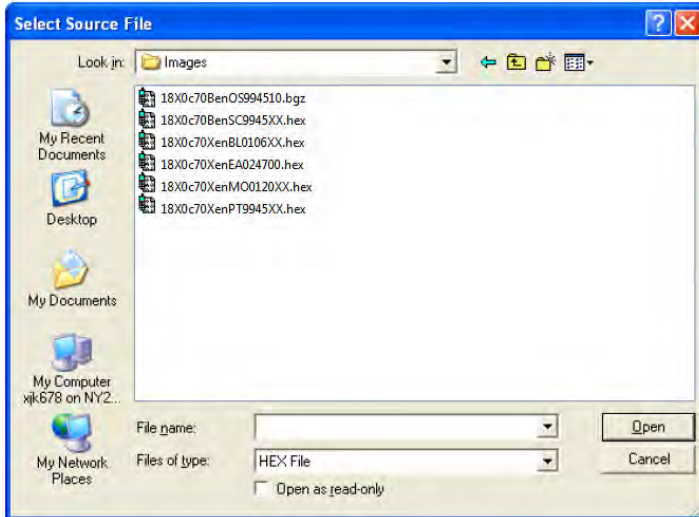
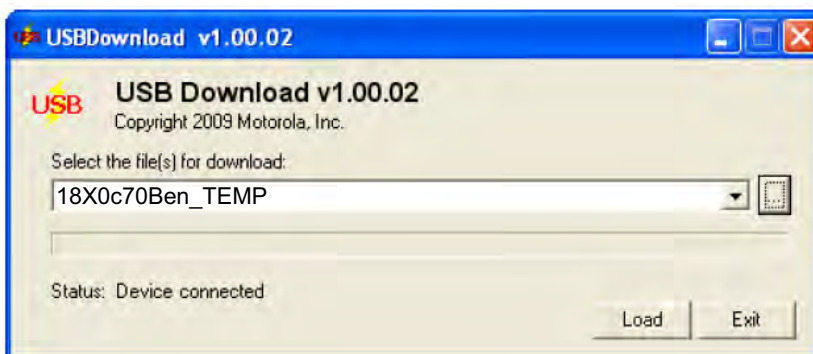

**Figure 9-8** Select Source File Window

**NOTE** One hex file or multiple hex files can be selected. To select multiple files, press the Ctrl key while selecting files.

If selecting multiple files to download, USBDownload reads the header of the file and identifies the file type. If the Partition table file is among the files selected, then USBDownload downloads that file first. Similarly, USBDownload downloads the CPLD file last.

1. Select the hex files and the click **Open**.



**Figure 9-9** Select Hex File(s)

2. Click the **LOAD** button. The hex file(s) is downloaded to the device.

```

Splash screen
#### (20)          100%
Download complete
in - 0.042 seconds
(1854142 bytes/second)

Hit Enter to Acknowledge

Bootloader 1.02.0000

```

**Figure 9-10** Download Complete Screen

3. On completion, press **ENTER** to return to the Bootloader main screen to select the next file to download.
4. To exit Bootloader, select **Exit** from the Bootloader main screen and press **ENTER**.

## Bootloader Error Detection

While receiving data, Bootloader performs many checks on the data to ensure that the data is received correctly. If an error is detected, Bootloader immediately aborts the download, and reports the error on an error screen.

This error message screen displays until a key is pressed. Once the screen is acknowledged, Bootloader returns to the main menu to wait for a new selection.

To find the probable cause of the error, use the error number and/or the error text displayed on the screen to look up the error in [Table 9-1](#).

**Table 9-1** IPL Errors

Error Text	Error Number	Probable Cause
Unknown error	-1	A general error occurred. Retry the download. If the failure persists, it is most likely due to a hardware failure; the MC18 requires servicing.
Cancelled by user	-2	The user canceled the download.
Can't open the source	-7	An error occurred opening the source device (either radio card or Serial port). Check source device connectivity and retry.
Can't open the destination	-8	An error occurred opening the destination device (either flash ROM or Power Micro). Retry the download. If the failure persists, it is most likely due to a hardware failure; the MC18 requires servicing.
Can't read from the source device	-9	The source device (either radio card or Serial port) could not be read from. Check source device connectivity and retry.
Can't write to the destination device	-10	The destination device (either flash ROM or Power Micro) could not be written to. Retry the download. If the failure persists, it is most likely due to a hardware failure; the MC18 requires servicing.

**Table 9-1** IPL Errors (Continued)

Error Text	Error Number	Probable Cause
Transmission checksum error	-11	An error occurred during transmission from the source device (either radio card or Serial port) and the checksum check failed. Check source device connectivity and retry.
Readback checksum error	-12	A checksum, generated from reading back data that was written to the destination device, was incorrect. An error during transmission or a write error to the destination device could cause this.
There is no more heap space available	-14	There is no more heap space available for the download procedure. Restart IPL and retry the download. If the failure persists, contact service with details of what is being downloaded.
Insufficient data available to complete record	-21	A Symbol HEX file download was attempted but the HEX file is invalid. Ensure the file is in Symbol HEX file format.
Invalid Symbol HEX file	-23	A Symbol HEX file download was attempted but the HEX file is invalid. Ensure the file is in Symbol HEX file format.
Unrecognized or unsupported HEX record	-24	The Symbol HEX file being downloaded contains an invalid or unrecognized HEX record. Ensure the file is in proper Symbol HEX file format.
Invalid data in HEX file	-25	The Symbol HEX file being downloaded contains invalid data. Ensure the file is in proper Symbol HEX file format with valid HEX data.
Exceeded max size	-26	The download file is too large to fit into the space allocated for it. Either make the file smaller or increase the space allocated for it by altering the partition table.
Partition is not valid on this device	-27	The downloaded file specifies a partition entry that does not exist on the device. Only download files that are valid for this device, or change the partition table so that the new file is valid on the device.
Wrong destination code	-28	A specific partition was chosen from the Main Menu (not Auto Select) but the file selected for download was for another partition. Ensure that the partition selected from the Main Menu matches the file selected for download.
File type does not support IPL Auto Select	-29	Monitor, Power Micro and Partition Table cannot be loaded with Auto Select. Select the appropriate area, and try again.
Non-contiguous record found	-30	A Symbol HEX file download was attempted but the HEX file is invalid. Ensure the file is in Symbol HEX file format.
Timed Out - No data	-31	IPL was waiting for data from the source device but timed out before receiving any. Check the source device connectivity and retry.

**Table 9-1** IPL Errors (Continued)

Error Text	Error Number	Probable Cause
Fail: Buffer Overrun	-32	The serial port device could not keep up with incoming data. Retry the serial download with a lower baud rate.
Partition Table not Valid	-33	The size of flash memory is different than that described in the partition table. Retry the download with the correct partition table file.
Invalid file format	-34	The file format is invalid. Only Symbol HEX files are supported by IPL.

---

## Mobility Services Platform

The MSP Client Software is a set of software components that come pre-installed on the MC18.

The MSP Client software consists of the following components:

The RD Client provides support for MSP Staging functionality, provides support for the MSP Legacy Staging process, and provides support for backward-compatible legacy MSP 2.x Legacy Staging functionality.

The MSP Agent provides MSP Provisioning functionality and Control functionality when used with MSP 3.2 Control Edition.

Refer to the Mobility Services Platform 3.2 User's Guide, p/n 72E-100158-06, for instructions for using the Rapid Deployment and MSP Agent clients.

---

## Creating a Splash Screen

A custom splash screen can be created and loaded onto the MC18. To create a custom splash screen:

1. Create a .bmp file using a graphic program with the following specifications:
  - Size: 216 (W) x 320 (H).
  - Colors: 256.
2. Modify the bitmap file and save.

To load the splash screen:

1. Convert the bmp file into a hex file using the OSUpdate Package Builder that is part of MSP.
2. Copy the hex file to the MC18 using BootLoader.

## OS Update

When operating system images are updated, new update images will be available as part of the Device Configuration Package (DCP) on the Support Central web site at: <http://supportcentral.motorola.com>.

Use this procedure to load a new operating system using OS Update:

1. Download the latest DCP for the MC18 or MC18A from the Support Central web site. See for *Device Configuration Package on page 9-1* detailed instructions.
2. Connect the MC18 to a host computer (see *Connecting the MC18 to a Host Computer on page 4-2*).
3. Use a remote control software on the host computer to view the CE desktop (see *Connecting the MC18 to a Host Computer on page 4-2*) for more information.
4. Open your ActiveSyncRemoteDisplay application on your desktop to give you a remote view to the WinCE device.
5. Select **Start > Settings > Control Panel**. The **Control Panel** window appears.
6. Click the **System** icon. The **System Properties** window appears.
7. Click the **Memory** tab.
8. Move the slider bar towards the right to increase total **Storage memory** to around 36000KB total.

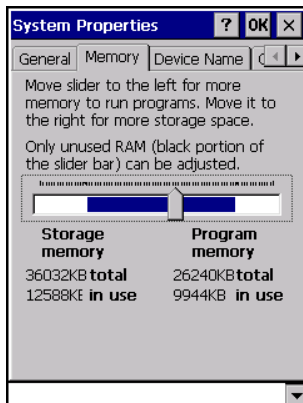
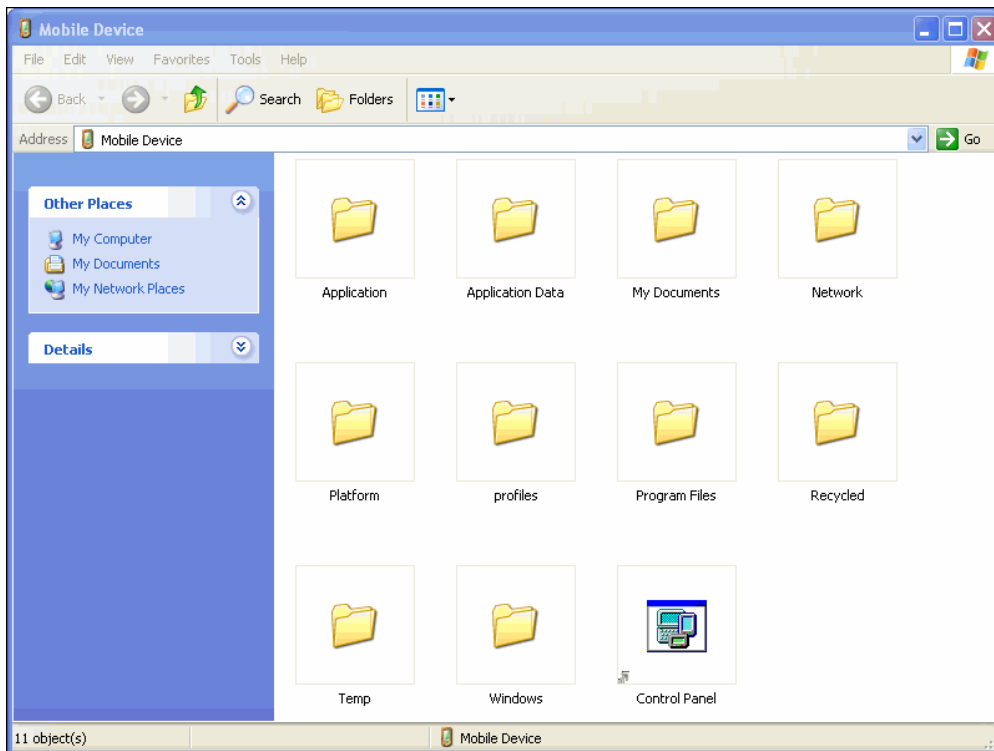

Figure 9-11 Memory Tab

9. Select **OK** to close the **System Properties** window.
10. Close the **Control Panel** window.
11. On the host computer, open a **Windows Explorer** window and navigate to the C:\Program Files\Symbol Device Configuration Packages\MC18xxc50Ben\V1.x folder.
12. In the **ActiveSync** or **Windows Mobile device Center** window, click the **Explore** or **File Management** to explore the MC18 file directories.





**Figure 9-12** Explorer Window

13. Copy the `/OSupdate` folder to the `/Temp` folder on the MC18.
14. Using the remote control software, navigate to `/Temp/OSUpdate` folder on the MC18. Select **View > Details** to display the whole filename.

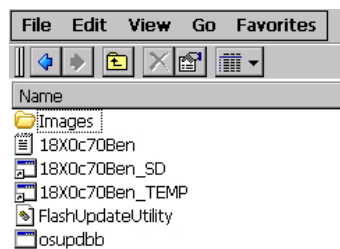

**Figure 9-13** Temp Directory

15. Double-click the `18X0c70Ben_TEMP` filename to launch the OSUpdate utility.
16. Once the update is completed the MC18 automatically cold boots.
17. Remove the MC18 from the cradle and re-insert after approximately one minute.

---

## Flash Storage

In addition to the RAM-based storage standard on Windows CE mobile computers, the MC18 is also equipped with a non-volatile Flash-based storage area which can store data (partitions) that can not be corrupted by a cold boot. This Flash area is divided into two categories: Flash File System (FFS) Partitions and Non-FFS Partitions.

### FFS Partitions

The MC18 includes two FFS partitions. These partitions appear to the MC18 as a hard drive that the OS file system can write files to and read files from. Data is retained even if power is removed.

The two FFS partitions appear as two separate folders in the Windows CE file system and are as follows:

- Platform: The Platform FFS partition contains Symbol-supplied programs and Dynamic Link Libraries (DLLs). This FFS is configured to include DLLs that control system operation. Since these drivers are required for basic MC18 operation, only experienced users should modify the content of this partition.
- Application: The Application FFS partition is used to store application programs needed to operate the MC18.

### Working with FFS Partitions

Because the FFS partitions appear as folders under the Windows CE file system, they can be written to and read like any other folder. For example, an application program can write data to a file located in the Application folder just as it would to the Windows folder. However, the file in the Application folder is in non-volatile storage and is not lost on a cold boot (e.g., when power is removed for a long period of time).

Standard tools such as ActiveSync or Windows Mobile Device Center can be used to copy files to and from the FFS partitions. They appear as the "Application" and "Platform" folders to the ActiveSync explorer. This is useful when installing applications on the MC18. Applications stored in the Application folder are retained even when the MC18 is cold booted.

There are two device drivers included in the Windows CE image to assist developers in configuring the MC18 following a cold boot: RegMerge and CopyFiles.

#### RegMerge.dll

RegMerge.dll is a built-in driver that allows registry edits to be made to the Windows CE Registry. Regmerge.dll runs very early in the boot process and looks for registry files (.reg files) in certain Flash File System folders during a cold boot. It then merges the registry changes into the system registry located in RAM.

Since the registry is re-created on every cold boot from the default ROM image, the RegMerge driver is necessary to make registry modifications persistent over cold boots.

RegMerge is configured to look in the root of two specific folders for .reg files in the following order:

- \Platform
- \Application

Regmerge continues to look for .reg files in these folders until all folders are checked. This allows folders later in the list to override folders earlier in the list. This way, it is possible to override Registry changes made by the

Platforms partitions folders. Take care when using Regmerge to make Registry changes. The DCP for MC18xxc50 contains examples of .reg files.

✓ **NOTE** Regmerge only merges the .reg files on cold boots. The merge process is skipped during a warm boot.

Typically, do not make modifications to registry values for drivers loaded before RegMerge. However, these values may require modification during software development. Since these early loading drivers read these keys before RegMerge gets a chance to change them, the MC18 must be cold booted. The warm boot does not re-initialize the registry and the early loading driver reads the new registry values.

Do not use Regmerge to modify built-in driver registry values, or merge the same Registry value to two files in the same folder, as the results are undefined.

### CopyFiles

Windows CE expects certain files to be in the Windows folder, residing in volatile storage. Windows CE maintains the System Registry in volatile storage. CopyFiles copies files from one folder to another on a cold boot. Files can be copied from a non-volatile partition (Application or Platform) to the Windows or other volatile partition during a cold boot. During a cold boot CopyFiles looks for files with a .CPY extension in the root of the Platform and Application FFS partitions (Platform first and then Application). These files are text files containing the source and destination for the desired files to be copied separated by ">". The following example from the file application.cpy is contained on the demo application partition included in the DCP for MC18xxc50.

Files are copied to the Windows folder from the Flash File System using copy files (\*.cpy) in the following order:

```
\Platform
  \Application
```

Example:

```
\Application\ScanSamp2.exe>\Windows\ScanSamp2.exe
```

This line directs CopyFiles to copy the ScanSamp2.exe application from the \Application folder to the \Windows folder.

### Non-FFS Partitions

Non-FFS Partitions include additional software and data pre-loaded on the MC18 that can be upgraded. Unlike FFS Partitions, these partitions are not visible when the operating system is running. They also contain system information. Non-FFS partitions include the following:

- Windows CE: The complete Windows CE operating system is stored on Flash devices. If necessary, the entire OS image may be downloaded to the MC18 using files provided by Symbol Technologies. The current OS partition on the MC18 is included as part of the TCM installation package. Any upgrades must be obtained from Symbol Technologies. This partition is mandatory for the MC18.
- Splash Screen: a bitmap smaller than 16 kb (and limited to 8 bits per pixel) is displayed as the MC18 cold boots.

✓ **NOTE** 8 bits per pixel only applies to splash screen images. Once Windows CE is running, the color density is 16 bits per pixel.

- IPL: This program interfaces with the host computer and allows downloading via cradle or serial cable any or all of the partitions listed above, as well as updated versions of IPL. Use caution downloading

updated IPL versions; incorrect downloading of an IPL causes permanent damage to the MC18. IPL is mandatory for the MC18.

- Partition Table: Identifies where each partition is loaded in the MC18.

### **Downloading Partitions to the MC18**

TCM is used to specify a hex destination file for each partition and download each file to the MC18. This download requires a program loader stored on the MC18. The MC18 comes with a program loading utility, Initial Program Loader (IPL), stored in the MC18's write-protected flash.

# CHAPTER 10 MAINTENANCE AND TROUBLESHOOTING

---

## Introduction

This chapter includes instructions on cleaning and storing the MC18, battery maintenance and provides troubleshooting solutions for potential problems during MC18 operating.

---

## Maintaining the MC18

For trouble-free service, observe the following tips when using the MC18:

- Protect the MC18 from temperature extremes.
- Do not store or use the MC18 in any location that is extremely dusty, damp, or wet.
- Use a soft lens cloth to clean the scan exit window of the MC18. If the surface of the MC18 screen becomes soiled, clean it with a soft cloth moistened with a diluted window-cleaning solution. Do not use bleach or ammonia.
- Take care not to scratch the screen of the MC18.
- The display of the MC18 contains glass. Take care not to drop the MC18 or subject it to strong impact.

---

## Battery Safety Guidelines

- The area in which the MC18 units are charged should be clear of debris and combustible materials or chemicals. Particular care should be taken where the device is charged in a non-commercial environment.
- Do not use incompatible batteries and chargers. If you have any questions about the compatibility of a battery or a charger, contact Symbol Technologies Global Customer Support. See [Service Information on page xiv](#) for contact information.
- Do not crush, puncture, or place a high degree of pressure on the battery.
- Follow battery usage, storage, and charging guidelines found in the MC18 Quick Reference Guide.
- Improper battery use may result in a fire, explosion, or other hazard.

- To charge the mobile device battery, the battery and charger temperatures must be between +32°F and +104°F (0°C and +40°C)
- Do not disassemble or open, crush, bend or deform, puncture, or shred.
- Severe impact from dropping any battery-operated device on a hard surface could cause the battery to overheat.
- Do not short circuit a battery or allow metallic or conductive objects to contact the battery terminals.
- Do not modify or remanufacture, attempt to insert foreign objects into the battery, immerse or expose to water or other liquids, or expose to fire, explosion, or other hazard.
- Do not leave or store the equipment in or near areas that might get very hot, such as in a parked vehicle or near a radiator or other heat source. Do not place battery into a microwave oven or dryer.
- Battery usage by children should be supervised.
- Please follow local regulations to promptly dispose of used re-chargeable batteries.
- Do not dispose of batteries in fire.
- Seek medical advice immediately if a battery has been swallowed.
- In the event of a battery leak, do not allow the liquid to come in contact with the skin or eyes. If contact has been made, wash the affected area with large amounts of water and seek medical advice.
- If you suspect damage to your equipment or battery, call Symbol Technologies Global Customer Support to arrange for inspection. See [Service Information on page xiv](#) for contact information.

---

## Long Term Storage

When storing the MC18 for a long period of time it is recommended to remove the battery.

When returning the MC18 to everyday operation, install a fully charged battery.

---

## Cleaning



**CAUTION** Always wear eye protection.

Read warning label on compressed air and alcohol product before using.

If you have to use any other solution for medical reasons please contact Symbol Technologies for more information.



**WARNING!** Avoid exposing this product to contact with hot oil or other flammable liquids. If such exposure occurs, unplug the device and clean the product immediately in accordance with these guidelines.

## Materials Required

- Alcohol wipes
- Lens tissue
- Cotton tipped applicators

- Isopropyl alcohol
- Can of compressed air with a tube.

## Cleaning the MC18

### Housing

Using the alcohol wipes, wipe the housing including the scan key.

### Display

The display can be wiped down with the alcohol wipes, but care should be taken not to allow any pooling of liquid around the edges of the display. Immediately dried the display with a soft, non-abrasive cloth to prevent streaking.

### Scan Exit Window

Wipe the scan exit window periodically with a lens tissue or other material suitable for cleaning optical material such as eyeglasses.

### Power Connector

1. Remove the main battery from MC18. See [Removing the Battery on page 1-9](#).
2. Install the battery cover.
3. Dip the cotton portion of the cotton tipped applicator in isopropyl alcohol.
4. Repeat at least three times.
5. Use the cotton tipped applicator dipped in alcohol to remove any grease and dirt near the connector area.
6. Use a dry cotton tipped applicator and repeat steps 3 through 6.
7. Spray compressed air on the connector area by pointing the tube/nozzle about ½ inch away from the surface.



**CAUTION** Do not point nozzle at yourself and others, ensure the nozzle or tube is away from your face.

8. Inspect the area for any grease or dirt, repeat if required.

## Cleaning Cradle Connectors

Use this procedure to clean the connectors on a cradle:

1. Remove power from the cradle.
2. Dip the cotton portion of the cotton tipped applicator in isopropyl alcohol.
3. Rub the cotton portion of the cotton tipped applicator along the pins of the connector. Slowly move the applicator back-and-forth from one side of the connector to the other. Do not let any cotton residue on the connector.
4. All sides of the connector should also be rubbed with the cotton tipped applicator.

5. Spray compressed air in the connector area by pointing the tube/nozzle about ½ inch away from the surface.



**CAUTION** Do not point nozzle at yourself and others, ensure the nozzle or tube is pointed away from your face.

6. Ensure that there is no lint left by the cotton tipped applicator, remove lint if found.
7. If grease and other dirt can be found on other areas of the cradle, use lint free cloth and alcohol to remove.
8. Allow at least 10 to 30 minutes (depending on ambient temperature and humidity) for the alcohol to air dry before applying power to cradle.

If the temperature is low and humidity is high, longer drying time is required. Warm temperature and dry humidity requires less drying time.

## Cleaning Frequency

The cleaning frequency is up to the customer's discretion due to the varied environments in which the MC18 units are used. They may be cleaned as frequently as required. However when used in dirty environments it may be advisable to periodically clean the scanner exit window to ensure optimum scanning performance.



## Troubleshooting

### MC18

**Table 10-1** Troubleshooting the MC18

Problem	Cause	Solution
MC18 does not turn on.	Battery not charged.	Charge or replace the battery in the MC18.
	Battery not installed properly.	Ensure battery is installed properly. See <a href="#">Installing the Battery on page 1-8</a> .
	System crash.	Perform a warm boot. If the MC18 still does not turn on, perform a cold boot. See <a href="#">Resetting the MC18 on page 1-16</a> .
Battery did not charge.	Battery failed.	Replace battery. If the MC18 still does not operate, try a warm boot, then a cold boot. See <a href="#">Resetting the MC18 on page 1-16</a> .
	MC18 removed from cradle before charging completed.	Insert the MC18 into the cradle and begin charging. The battery fully charges in approximately four hours.
	Ambient temperature of the cradle is too warm or too cold.	The ambient temperature must be between 0 °C and 40 °C (32 °F and 104 °F).
During data communication, no data was transmitted, or transmitted data was incomplete.	MC18 unplugged from host computer during communication.	Reconnect the programming cable to the host computer and re-transmit.
	Communication software was incorrectly installed or configured.	Ensure that Microsoft ActiveSync 4.5 / Windows Mobile Device Center 6.1 or greater is installed on the host computer.

**Table 10-1** Troubleshooting the MC18 (Continued)

<b>Problem</b>	<b>Cause</b>	<b>Solution</b>
MC18 turns itself off.	MC18 is inactive.	The MC18 turns off after a period of inactivity. If the MC18 is running on battery power, this period can be set to 1, 2, 3, 4, 5 minutes. If the MC18 is running on external power, this period can be set to 1, 2, 3, 5, 10, 15 and 30 minutes. Check the power settings by selecting <b>Start &gt; Settings &gt; Control Panel &gt; Power</b> icon > <b>Advanced</b> tab. Change the setting if you need a longer delay before the automatic shutoff feature activates.
	Battery is depleted.	Place the MC18 in the cradle to re-charge the battery.
	Battery is not inserted properly.	Insert the battery properly (see <a href="#">Installing the Battery on page 1-8</a> ).
	The MC18's battery is low and it powers down to protect memory content.	Place the MC18 in the cradle to re-charge the battery.
A message appears stating that the MC18 memory is full.	Too many files stored on the MC18.	Delete unused memos and records. You can save these records on the host computer.
	Too many applications installed on the MC18.	If you have installed additional applications on the MC18, remove them to recover memory. Select <b>Start &gt; Settings &gt; Control Panel &gt; Remove Programs</b> icon. Select the unused program and select <b>Remove</b> .
The MC18 does not accept scan input.	Scanning application is not loaded.	Verify that the MC18 is loaded with a scanning application. See the System Administrator.
	Unreadable bar code.	Ensure the symbol is not defaced.
	Distance between imager exit window and bar code is incorrect.	Move the MC18 closer or further from the bar code to the proper scanning range.
	MC18 is not programmed for the bar code.	Verify that the MC18 can read the type of bar code being scanned (See <a href="#">Technical Specifications</a> ). Ensure that the bar code parameters are set properly for the bar code being scanned.
	MC18 is not programmed to generate a beep.	Click <b>Start &gt; Programs &gt; CtPanel &gt; Audio Settings</b> and verify that a beep on a good decode is used and the <b>Beeper Volume</b> is not set to 0.
	Battery is low.	If the scanner is still not reading symbols, contact the distributor or service.

**Table 10-1** Troubleshooting the MC18 (Continued)

Problem	Cause	Solution
During USB data communications, no data was transmitted, or transmitted data was incomplete.	Incorrect cable connection.	See <a href="#">Connecting the MC18 to a Host Computer on page 4-2</a> .
	Communications software is not installed or configured properly.	Perform setup as described in <a href="#">Chapter 8, Cradle Installation</a> . Ensure that a sync program is installed on the host computer.
Cannot sync with Host Computer	Host computer not configured properly.	Ensure that sync program on the host computer is set to allow USB connections. See <a href="#">Chapter 4, Sync with Host Computer</a> for more information.

## Cradles

**Table 10-2** Troubleshooting the Cradles

Symptom	Possible Cause	Solution
MC18 battery is not charging.	MC18 was removed from cradle or cradle was unplugged from AC power.	Ensure cradle is receiving power. Ensure MC18 is seated correctly. Confirm main battery is charging. The battery fully charges in approximately four hours. View battery status by selecting <b>Start &gt; Settings &gt; Control Panel &gt; Power</b> icon.
	Battery is faulty.	Verify that other batteries charge properly. If so, replace the faulty battery (see <a href="#">Installing the Battery on page 1-8</a> ).
	The MC18 is not fully seated in the cradle.	Remove and re-insert the MC18 into the cradle, ensuring it is firmly seated.
	Ambient temperature of the cradle is too warm or too cold.	Move the cradle to an area where the ambient temperature is between 0 °C and 40 °C (32 °F and 104 °F).
It is taking longer than four hours to charge the MC18.	MC18 is not optimized for low radio signal strength.	Refer to <a href="#">Tips for Improving Battery Charge Time on page 6-3</a> for information on optimizing the MC18.



# APPENDIX A TECHNICAL SPECIFICATIONS

## Technical Specifications

The following tables summarize the MC18's intended operating environment and general technical hardware specifications.

**Table A-1** *Technical Specifications*

Item	Description
<b>Physical and Environmental Characteristics</b>	
Dimensions (H x L x W)	3.12 in. x 8.07 in. x 2.94 in. (7.95 cm x 20.5 cm x 7.47 cm)
Weight	297 g (10.47 oz) with battery
Keys	Single scan key
Display	Color LCD, 4",480x800 WVGA resolution, 16 bits/pixel RGB, 450 Nits LED backlight, capacitive touch screen
Speaker	2W speaker
Main Battery	"Gifted" battery, rechargeable 3.7 VDC Lithium Ion battery. Standard capacity: 2,590mAh.
<b>Performance Characteristics</b>	
CPU	TI OMAP4430 (MPA3), Dual Core, 800MHz
Operating System	Windows CE 7 Professional, Microsoft Internet Explorer CE 7
Memory	Configuration: Flash - 2GB, RAN - 512MB High Memory Configuration: Flash - 4GB, RAN - 1GB
Application Development	EMDK for C, EMDK for .NET extended to include MC18 specific APIs. EMDKs are available through Support Central web site

**Table A-1** *Technical Specifications (Continued)*

Item	Description
Data Capture Method	Imager (SE4710) with red LED Illumination and LED dot aim pattern. Imaging rate: 30 Frames per second, 1280p x 800p Imager Safety IEC/FDA Class 1 in accordance with IEC/EN 60825-1 & 21 CFR 1040.10 & 11 (Laser Notice No. 50)
<b>User Environment</b>	
Operating Temperature	0° C to 40° C (32° F to 104° F)
Storage Temperature	-20° C to 60° C (-4° F to 140° F)
Battery Charging Temperature	0° C to +40° C (32° F to 104° F) ambient temperature range.
Humidity	40° C (RH 10% - 95%) Non-condensing
Flammability	UL94V1
Drop Specification	Multiple 4 ft.(1.2 m) drops to tile linoleum over concrete across operating temperature range
Sealing	Liquid penetration per “A4T Casual Spill Test Spec” document number 71-98611-01. Applies ONLY with battery installed.
ESD	± 20k VDC air discharge ± 10k VDC contact discharge
<b>Interface/ Communications</b>	
WLAN radio	TI / 1273L - Wi-Fi IEEE® 802.11a/b/g/n with internal antenna Operating Channels: Channel 1 - 13 (2412 - 2472 MHz) Actual operating frequencies depend on regulatory rules and certification agency. Authentication: EAP-TTLS authentication with tunnel types CHAP, MSCHAP, MSCHAPv2, PAP, MD5, EAP-TLS, PEAP-TLS authentication with tunnel types TLS, MSCHAPv2, and GTC, LEAP, EAP-FAST authentication with tunnel types TLS, MSCHAPv2, and GTCon, EAP-AKA , WAPI Encryption: None, 128-bit AES, TKIP, WEP-128, WEP-40/65
Bluetooth Communications	TI / 1273L - MS stack 2.1
USB	USB 2.0 Client for Microsoft ActiveSync or Windows Mobile Device Center, for service and maintenance
<b>Regulatory</b>	
Electrical Safety	Certified to UL/cUL 60950-1, IEC 60950-1 ; IEC 62471:2006/EN62471:2008 (LED Safety Report)
EMI/RFI	North America: FCC Part 15 Subpart B class B Canada: ICES 003 Class B EU: EN55022 Class B, EN 301 489-1, EN301 489-17, EN61000-4-3/-3-2/-3-3

**Table A-1** *Technical Specifications (Continued)*

Item	Description
FCC	RF FCC Part 15 subpart C and E , RSS 210 Anex 8 and 9, EN 300 328, EN 301 893, AS/NZS 426
Electrical Safety/ Laser Safety	Certified to UL/cUL 60950-1, EN/IEC 60950-1 IEC 62471:2006 and EN 62471:2008 (LED Safety Report).
EMI/RFI	North America: FCC Part 15 Subpart B class B Canada: ICES 003 Class B EU: EN55022 Class B, EN 301 489-1, EN 301 489-17, EN61000-4-3/-3-2/-3-3 Australia: AS/NZS CISPR 22
Imager Decode Capability	<p>The SE4710 2D supports barcode symbologies listed below (The specific engine configuration is identified / readable in the system configuration).</p> <ul style="list-style-type: none"> <li>• Code 39: Trioptic Code 39</li> <li>UPC/EAN: UPCA (+ add-on), UPCE (+ add-on), UPCE1, EAN-8, EAN-13 (+ add-on), JAN-8 (Note: This is supported but not handled separately from EAN8 or EAN 13), JAN-13 (+ add-on), SBN / Bookland (+ISBN 13), ISSN, Coupon Codes including GS1 Databar Expanded Format.</li> <li>• Code 128: ISBT-128, UCC/EAN 128, GS1-128 (Note this is the new name for EANUCC-128)</li> <li>• Code 93</li> <li>• MSI</li> <li>• Codabar: ABC, Ames</li> <li>• 2 of 5: Interleaved 2 of 5 / ITF, Discrete 2 of 5, IATA, Chinese 2 of 5, Code 11, Matrix 2 of 5</li> <li>• Korean 3 of 5</li> <li>• RSS/GS1 data bar: GS1-DataBar (Previously known as RSS), GS1-DataBar Limited, GS1-DataBar Expanded (Including stacked)</li> <li>• 2D symbologies</li> <li>• PDF-417: Macro PDF, Macro Micro PDF, Composite, Composite C, Composite AB</li> <li>• Data Matrix: GS1-Datamatrix</li> <li>• QR code: Micro QR, GS1-QR code</li> <li>• Aztec</li> <li>• Maxicode</li> <li>• Han Xin (Chinese Sensible Code)</li> <li>• Postal codes: Linked Aztec, US Planet, US Postnet, US Intelligent Mail, Royal Mail 4 State, USPS 4CB/OneCode/Intelligent Mail, UPU FICS Postal, UK Postal, Japan Postal, Australian Postal, Canada Post, Netherlands KIX Code</li> <li>• Image capture</li> <li>• Signature capture</li> </ul>

## Three Slot Cradle

**Table A-2** *Cradle Specifications*

Item	Description
Operating Temperature	0° C to +50° C (32° F to 122° F)
Storage Temperature	-40° C to 70° C (-40° F to 158° F)
Battery Charging Temperature	0° C to +40° C (32° F to 104° F) ambient temperature
Humidity	5% to 95% non-condensing
Size (H x L x W)	129 mm x 134 mm x 310 mm (5 in x 5.2 in x 12.2 in)
Weight	
Power Supply	12.0 VDC,9.0 A
Electrostatic Discharge (ESD)	±15 kV air discharge, ± 8 kV contact discharge

## Single-Slot Cradle

**Table A-3** *Cradle Specifications*

Item	Description
Operating Temperature	0° C to +50° C (32° F to 122° F)
Storage Temperature	-40° C to 70° C (-40° F to 158° F)
Battery Charging Temperature	0° C to +40° C (32° F to 104° F) ambient temperature
Humidity	5% to 95% non-condensing
Size (L x W x H)	98 mm x 127 mm x 272 mm (4 in. x 5 in. x 10.7 in.)
Weight	652 g (23 oz)
Power Supply	12.0 VDC,9.0 A
Electrostatic Discharge (ESD)	±15 kV air discharge, ± 8 kV contact discharge



## MC18 Interface Connector Pin-Outs

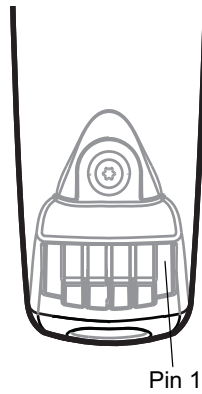

**Figure A-1** Power Connector Pin-Outs

**Table A-4** Power Connector Pin-Outs

PIN	Signal Name	Function
1	GND	Ground
2	TX	Transmit Output to Cradle
3	RX	Receive Input from Cradle
4	+5V	Input power.

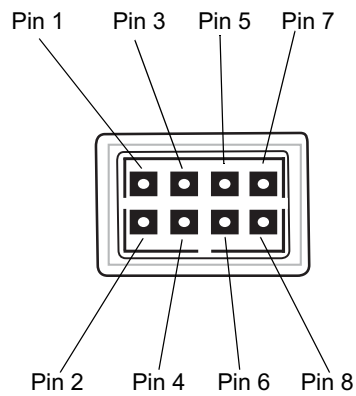

**Figure A-2** Sync Connector Pin-Outs

**Table A-5** Sync Connector Pin-Outs

PIN Number	Signal Name	Function
1	USB_PWR	+5 VDC
2	USBA0_OTG_DP	USB DATA +
3	Reserved	Not Used
4	USBA0_OTG_DM	USB DATA -

**Table A-5** Sync Connector Pin-Outs (Continued)

PIN Number	Signal Name	Function
5	Sys_Boot5	Not Used
6	GND	Forces system to cold boot from USB
7	UART4_TXD	Debug Transmit Output
8	UART4_RXD	Debug Receive Input

## Cable Specifications

### Power Supply Cable, Y-type

**Table A-6** Wire Run List & Specifications

Wire Color	AWG	Connector 1 Molex 39-01-2060 housing; 4x, 39-00-0211 contacts	Connector 2 Molex 39-01-2025 housing; 2x, 39-00-0211 contacts	Connector 3 Molex 39-01-2025 housing; 2x, 39-00-0211 contacts	Function
Red	16	1	1		(+) term
Black	16	6	2		(-) term
Red	16	2		1	(+) term
Black	16	5		2	(-) term

The 16 AWG wire should have the following specifications: UL1007, 300 Volt, PVC, -40° C to 80° C operating temperature.

### Cradle Interconnection Cable

**Table A-7** Wire Run List & Specifications

Wire Color	AWG	Connector 1 Molex 39-01-2025 housing; 2x, 39-00-0211 contacts	Connector 2 Molex 39-01-2025 housing; 2x, 39-00-0211 contacts	Function
Red	16	1	1	(+) term
Black	16	2	2	(-) term

The 16 AWG wire should have the following specifications: UL1007, 300 Volt, PVC, -40° C to 80° C operating temperature.



# APPENDIX B APP LAUNCHER CONFIGURATION

---

## Configuration

The menu on the **App Launcher** window can be modified to display and launch any application on the MC18.



**Figure B-1** *Default App Launcher Window*

Use this procedure to customize the **App Launcher** menu:

1. Sync the MC18 with a host computer (See [Chapter 4, Sync with Host Computer](#)).
2. Copy the file `launcher.reg` from the `/Application` folder on the MC18 to a local directory on the host computer.
3. Open the file using a text editor.

4. The following lists the five default menu items that appear on the App Launcher display. Note that Exit menu item is not listed in the registry file.

```
[HKEY_CURRENT_USER\Software\Symbol\Launcher\Default\Programs\Prog1]
"Description"="RD Client"
"Name"="\\windows\rdclient.exe"
"Command"=" "
```

```
[HKEY_CURRENT_USER\Software\Motorola\AppLauncher\Profiles\DefaultProf\Default\
Programs]
```

```
"Description"="SPB"
"Name"="\\program files\SPB2_CE.exe"
"Command"=" "
```

```
[HKEY_CURRENT_USER\Software\Symbol\Launcher\Default\Programs\Prog3]
"Description"="Device Info"
"Name"="\\Windows\DeviceInfoApp.exe"
"Command"=" "
```

```
[HKEY_CURRENT_USER\Software\Symbol\Launcher\Default\Programs\Prog4]
"Description"="MC18-Scan"
"Name"="\\Application\MC18-Scan.EXE"
"Command"=" "
```

```
[HKEY_CURRENT_USER\Software\Symbol\Launcher\Default\Programs\Prog5]
"Description"="Reset"
"Name"="\\Windows\WarmBoot.EXE"
"Command"=" "
```

Use this procedure to add a sixth item to the list, enter the following after the warm boot entry:

```
[HKEY_CURRENT_USER\Software\Symbol\Launcher\Default\Programs\Prog6]
"Description"="Control Panel"
"Name"="\\Windows\CtlPanel.EXE"
"Command"=" "
```

1. Save the registry file.
2. Copy the file back to the */Application* folder on the MC18.
3. Cold boot the MC18.

# GLOSSARY

---

## Numeric

- 802.11.** A group of wireless specifications developed by the Institute of Electrical and Electronics Engineers (IEEE). It specifies an over-the-air interface between a wireless client and a base station or between two wireless clients.
- 802.11b.** Operates in the 2.4 GHz Industrial, Scientific and Measurement (ISM) band (2.4 to 2.4835 GHz) and provides signaling rates of up to 11Mbit/sec. This is a very commonly used frequency. Microwave ovens, cordless phones, medical and scientific equipment, as well as Bluetooth devices, all work within the 2.4 GHz ISM band.
- 802.11g.** Similar to 802.11b, but this standard supports signaling rates of up to 54Mbit/sec. It also operates in the heavily used 2.4 GHz ISM band but uses a different radio technology to boost overall throughput. Compatible with the 802.11b.
- 802.11n.** Wireless networking standard that uses multiple antennas to increase data rates to improve network performance over the two previous standards—802.11a and 802.11g—with a significant increase in the maximum net data rate from 54 Mbit/s to 600 Mbit/s. It can be used in the 2.4 GHz or 5 GHz frequency bands.

---

## A

- Access Point.** Provides a bridge between Ethernet wired LANs and the wireless network. Access points are the connectivity point between Ethernet wired networks and devices (laptops, hand-held computers, point-of-sale terminals) equipped with a wireless LAN adapter card.
- Ad Hoc Mode.** A wireless network framework in which devices communicate directly with one another without using an access point.
- API.** Application Programming interface - An interface by means of which one software component communicates with or controls another. Usually used to refer to services provided by one software component to another, usually via software interrupts or function calls
- Association.** The process of determining the viability of the wireless connection and establishing a wireless network's root and designated access points. A MC18 associates with its wireless network as soon as it is powered on or moves into range.

---

## B

**Bar Code.** A pattern of variable-width bars and spaces which represents numeric or alphanumeric data in machine-readable form. The general format of a bar code symbol consists of a leading margin, start character, data or message character, check character (if any), stop character, and trailing margin. Within this framework, each recognizable symbology uses its own unique format. See **Symbology**.

**Bits per Second (bps).** Bits transmitted or received.

**Bit.** Binary digit. One bit is the basic unit of binary information. Generally, eight consecutive bits compose one byte of data. The pattern of 0 and 1 values within the byte determines its meaning.

**Byte.** On an addressable boundary, eight adjacent binary digits (0 and 1) combined in a pattern to represent a specific character or numeric value. Bits are numbered from the right, 0 through 7, with bit 0 the low-order bit. One byte in memory is used to store one ASCII character.

**boot or boot-up.** The process a computer goes through when it starts. During boot-up, the computer can run self-diagnostic tests and configure hardware and software.

---

## C

**CAM.** (Continuously Aware Mode) Mode in which the adapter is instructed to continually check for network activity.

**CHAP.** (Challenge Handshake Authentication Protocol) A type of authentication in which the authentication agent (typically a network server) sends the client program a random value that is used only once and an ID value. Both the sender and peer share a predefined secret. The peer concatenates the random value (or nonce), the ID and the secret and calculates a one-way hash using MD5. The hash value is sent to the authenticator, which in turn builds that same string on its side, calculates the MD5 sum itself and compares the result with the value received from the peer. If the values match, the peer is authenticated.

**Character.** A pattern of bars and spaces which either directly represents data or indicates a control function, such as a number, letter, punctuation mark, or communications control contained in a message.

**Character Set.** Those characters available for encoding in a particular bar code symbology.

**Cold Boot.** A cold boot restarts the MC18 and erases all user stored records and entries.

**COM port.** Communication port; ports are identified by number, e.g., COM1, COM2.

**Continuous Code.** A bar code or symbol in which all spaces within the symbol are parts of characters. There are no intercharacter gaps in a continuous code. The absence of gaps allows for greater information density.

**Cradle.** A cradle is used for charging the MC18 battery and for communicating with a host computer, and provides a storage place for the MC18 when not in use.

---

## D

**DCP.** See **Device Configuration Package**.



**Decode.** To recognize a bar code symbology (e.g., UPC/EAN) and then analyze the content of the specific bar code scanned.

**Decode Algorithm.** A decoding scheme that converts pulse widths into data representation of the letters or numbers encoded within a bar code symbol.

**Decryption.** Decryption is the decoding and unscrambling of received encrypted data. Also see, **Encryption** and **Key**.

**Depth of Field.** The range between minimum and maximum distances at which a scanner can read a symbol with a certain minimum element width.

**Device Configuration Package.** The Device Configuration Package provides flash partitions, Terminal Configuration Manager (TCM) and the associated TCM scripts. With this package hex images that represent flash partitions can be created and downloaded to the MC18.

---

## E

**EAN.** (European Article Number) This European/International version of the UPC provides its own coding format and symbology standards. Element dimensions are specified metrically. EAN is used primarily in retail.

**EAP.** (Extensible Authentication Protocol) A general authentication protocol used to control network access. Many specific authentication methods work within this framework.

**EAP-PEAP.** (Extensible Authentication Protocol-Protected Extensible Authentication Protocol) A mutual authentication method that uses a combination of digital certificates and another system, such as passwords.

**EAP-TLS.** (Extensible Authentication Protocol-Transport Layer Security) A mutual authentication method that uses digital certificates.

**Encoded Area.** Total linear dimension occupied by all characters of a code pattern, including start/stop characters and data.

**Encryption.** Encoding data to prevent it from being read by unauthorized people.

**ENQ (RS-232).** ENQ software handshaking is also supported for the data sent to the host.

**EMDK.** Enterprise Mobility Developer's Kit.

**Ethernet.** An IEEE standard network protocol that specifies how data is placed on and retrieved from a common transmission medium.

---

## F

**Flash Memory.** Flash memory is nonvolatile, semi-permanent storage that can be electronically erased in the circuit and reprogrammed.

**File Transfer Protocol (FTP).** A TCP/IP application protocol governing file transfer via network or telephone lines. See **TCP/IP**.

---

## G

**Gifted Batteries.** A battery with advanced features such as: advanced state of battery health, more accurate state of charge, elapsed time since first use by customer, time to fully charge, time to fully discharge, estimate of capacity if battery were fully charged and operated under present load conditions and temperature.

---

## H

**Hard Reset.** See **Cold Boot**.

**Hz.** Hertz; A unit of frequency equal to one cycle per second.

**Host Computer.** A computer that serves other mobile computers in a network, providing such services as computation, database access, supervisory programs and network control.

---

## I

**IEC.** International Electrotechnical Commission. This international agency regulates laser safety by specifying various laser operation classes based on power output during operation.

**IEEE Address.** See **MAC Address**.

**Internet Protocol Address.** See **IP**.

**Input/Output Ports.** I/O ports are primarily dedicated to passing information into or out of the MC18's memory.

**IP.** (Internet Protocol) The IP part of the TCP/IP communications protocol. IP implements the network layer (layer 3) of the protocol, which contains a network address and is used to route a message to a different network or subnetwork. IP accepts "packets" from the layer 4 transport protocol (TCP or UDP), adds its own header to it and delivers a "datagram" to the layer 2 data link protocol. It may also break the packet into fragments to support the maximum transmission unit (MTU) of the network.

**IP Address.** (Internet Protocol address) The address of a computer attached to an IP network. Every client and server station must have a unique IP address. A 32-bit address used by a computer on a IP network. Client workstations have either a permanent address or one that is dynamically assigned to them each session. IP addresses are written as four sets of numbers separated by periods; for example, 204.171.64.2.

---

## K

**Key.** A key is the specific code used by the algorithm to encrypt or decrypt the data. Also see, **Encryption** and **Decrypting**.

---

## L

**Imager.** A type of bar code reader that uses a camera.

**LCD.** See **Liquid Crystal Display**.

**LEAP.** (Lightweight Extensible Authentication Protocol) A mutual authentication method that uses a username and password system.

**LED Indicator.** A semiconductor diode (LED - Light Emitting Diode) used as an indicator, often in digital displays. The semiconductor uses applied voltage to produce light of a certain frequency determined by the semiconductor's particular chemical composition.

**Liquid Crystal Display (LCD).** A display that uses liquid crystal sealed between two glass plates. The crystals are excited by precise electrical charges, causing them to reflect light outside according to their bias. They use little electricity and react relatively quickly. They require external light to reflect their information to the user.

---

## M

**Mobile Computer.** In this text, mobile computer refers to the MC18. It can be set up to run as a stand-alone device, or it can be set up to communicate with a network, using wireless radio technology.

**MSCHAP.** (Microsoft Challenge Handshake Authentication Protocol) is the Microsoft version of CHAP and is an extension to RFC 1994. Like the standard version of CHAP, MS-CHAP is used for PPP authentication; in this case, authentication occurs between a PC using Microsoft Windows NT or Microsoft Windows 95 and a Cisco router or access server acting as a network access server (NAS).

---

## N

**Nominal.** The exact (or ideal) intended value for a specified parameter. Tolerances are specified as positive and negative deviations from this value.

**Nominal Size.** Standard size for a bar code symbol. Most UPC/EAN codes are used over a range of magnifications (e.g., from 0.80 to 2.00 of nominal).

---

## P

**Parameter.** A variable that can have different values assigned to it.

**PING.** (Packet Internet Groper) An Internet utility used to determine whether a particular IP address is online. It is used to test and debug a network by sending out a packet and waiting for a response.

**Programming Mode.** The state in which a scanner is configured for parameter values. See **Scanning Mode**.

---

## Q

**Quiet Zone.** A clear space, containing no dark marks, which precedes the start character of a bar code symbol and follows the stop character.

---

## R

**RAM.** Random Access Memory. Data in RAM can be accessed in random order, and quickly written and read.

**RF.** Radio Frequency.

**ROM.** Read-Only Memory. Data stored in ROM cannot be changed or removed.

**Router.** A device that connects networks and supports the required protocols for packet filtering. Routers are typically used to extend the range of cabling and to organize the topology of a network into subnets. See **Subnet**.

---

## S

**Scanning Mode.** The scanner is energized, programmed and ready to read a bar code.

**Scanning Sequence.** A method of programming or configuring parameters for a bar code reading system by scanning bar code menus.

**SDK.** Software Development Kit

**Shared Key.** Shared Key authentication is an algorithm where both the AP and the MU share an authentication key.

**Soft Reset.** See **Warm Boot**.

**Specular Reflection.** The mirror-like direct reflection of light from a surface, which can cause difficulty decoding a bar code.

**Subnet.** A subset of nodes on a network that are serviced by the same router. See **Router**.

**Substrate.** A foundation material on which a substance or image is placed.

**Symbol.** A scannable unit that encodes data within the conventions of a certain symbology, usually including start/stop characters, quiet zones, data characters and check characters.

**Symbology.** The structural rules and conventions for representing data within a particular bar code type (e.g. UPC/EAN, Code 39, PDF417, etc.).

---

## T

**TCP/IP.** (Transmission Control Protocol/Internet Protocol) A communications protocol used to internetwork dissimilar systems. This standard is the protocol of the Internet and has become the global standard for communications. TCP

provides transport functions, which ensures that the total amount of bytes sent is received correctly at the other end. UDP is an alternate transport that does not guarantee delivery. It is widely used for real-time voice and video transmissions where erroneous packets are not retransmitted. IP provides the routing mechanism. TCP/IP is a routable protocol, which means that all messages contain not only the address of the destination station, but the address of a destination network. This allows TCP/IP messages to be sent to multiple networks within an organization or around the world, hence its use in the worldwide Internet. Every client and server in a TCP/IP network requires an IP address, which is either permanently assigned or dynamically assigned at startup.

**TFTP.** (Trivial File Transfer Protocol) A version of the TCP/IP FTP (File Transfer Protocol) protocol that has no directory or password capability. It is the protocol used for upgrading firmware, downloading software and remote booting of diskless devices.

**TKIP.** (Temporal Key Integrity Protocol) A wireless encryption protocol that periodically changes the encryption key, making it harder to decode.

**Transmission Control Protocol/Internet Protocol.** See **TCP/IP**.

**TLS.** (Transport Layer Security) TLS is a protocol that ensures privacy between communicating applications and their users on the Internet. When a server and client communicate, TLS ensures that no third party may eavesdrop or tamper with any message. TLS is the successor to the Secure Sockets Layer (SSL).

**Trivial File Transfer Protocol.** See **TFTP**.

---

## U

**UDP.** (User Datagram Protocol) A protocol within the IP protocol suite that is used in place of TCP when a reliable delivery is not required. For example, UDP is used for real-time audio and video traffic where lost packets are simply ignored, because there is no time to retransmit. If UDP is used and a reliable delivery is required, packet sequence checking and error notification must be written into the applications.

---

## W

**Warm Boot.** A warm boot restarts the MC18 by closing all running programs. All data that is not saved to flash memory is lost.

**WAP.** (Wireless Application Protocol) A set of specifications, developed by the WAP Forum, that lets developers using Wireless Markup Language build networked applications designed for handheld wireless devices. WAP was designed to work within the constraints of these devices: a limited memory and CPU size, small, monochrome screens, low bandwidth and erratic connections.

**WEP.** Wired-Equivalent Privacy protocol was specified in the IEEE 802.11 standard to provide a WLAN with a minimal level of security and privacy comparable to a typical wired LAN, using data encryption.

**WPA.** Wi-Fi Protected Access is a data encryption specification for 802.11 wireless networks that replaces the weaker WEP. It improves on WEP by using dynamic keys, Extensible Authentication Protocol to secure network access, and an encryption method called Temporal Key Integrity Protocol (TKIP) to secure data transmissions.

**WPA2.** Wi-Fi Protected Access 2 is an enhanced version of WPA. It uses Advanced Encryption Standard instead of TKIP.

**WLAN.** Wireless local-area networks use radio waves instead of a cable to connect a user device, such as a mobile computer, to a LAN. They provide Ethernet connections over the air and operate under the 802.11 family of specifications developed by the IEEE.

# INDEX

## Numerics

802.11b/g ..... A-2

## A

accessories ..... 1-4  
active and indicate programs ..... 5-7  
ActiveSync ..... 4-1  
    downloading files ..... 9-3  
    installing ..... 4-1  
    setting up a connection ..... 4-2  
AirBEAM  
    Client ..... B-2  
    configuring ..... B-2  
    package builder ..... B-1  
    staging ..... B-9  
    synchronization with server ..... B-8  
AirBEAM configuration  
    Misc(1) tab ..... B-4  
    Misc(2) tab ..... B-5  
    Packages(2) tab ..... B-3  
    Server tab ..... B-4  
App Launcher  
    configuration ..... C-1

## B

backlight ..... 6-2, 6-3  
battery  
    charging ..... 1-6, 1-9  
        temperature range ..... A-3  
    clearing ..... 10-2  
    improving battery life ..... 6-3  
    installing ..... 1-6  
    replacement ..... 10-2  
    service ..... 10-2

        status ..... 5-7  
battery charge status ..... 5-7  
battery charging temperature ..... A-2  
battery management ..... 10-2  
battery status ..... 5-7, 5-8  
bezel ..... 1-16  
bezel replacement ..... 1-16  
boot  
    cold ..... 1-12, 1-15  
    warm ..... 1-15  
bullets ..... xv

## C

changing the power settings ..... 6-4  
charging  
    temperature range ..... A-3  
charging battery ..... 1-9  
cradle ..... 1-4, 1-10, 1-11  
cleaning ..... 10-1  
clock, display ..... 5-11  
cold boot ..... 1-12, 1-15, 9-23  
communication status ..... 5-7  
configuration ..... xii  
configurations ..... xii  
conventions  
    notational ..... xv  
CPU ..... A-1  
cradle key ..... 1-4  
creating splash screen ..... 9-18

## D

daisy chain cable ..... 1-4  
data capture ..... xii  
    adjusting the distance ..... 1-14  
    indicator ..... 1-14

- scan angle ..... 1-13
- scan range ..... 1-13
- scanning ..... 1-13
- DCP ..... 9-1
- DCP for MC18xxc50 ..... xv, 9-5, 9-8, 9-18, 9-24
- programming cable ..... 1-4
- Device Configuration Package ..... 9-1
- Device Configuration Package for MC18xxc50 .. xv, 9-5, 9-8, ..... 9-18, 9-24
- dimensions ..... A-1
- dispenser key ..... 1-10
- display ..... xii, A-1
- display backlight
  - saving power ..... 6-4
- display clock ..... 5-11
- documents ..... 5-9
- downloading files ..... 9-3
- drop specification ..... A-2

**E**

- electrical safety ..... A-3
- EMDK for C ..... 9-1
- EMDK for eVC4 ..... xv
- Enterprise Mobility Developer Kit for C ..... 9-1
- Enterprise Mobility Developer Kit for eVC4 ..... xv
- error messages ..... 9-14, 9-16

**F**

- favorites ..... 5-9
- file explorer ..... 9-5
- flash file system ..... 9-23
  - downloading partitions ..... 9-25
  - non-FFS partitions ..... 9-24
    - IPL ..... 9-25
    - splash screen ..... 9-24
  - partitions ..... 9-23
    - copyfile ..... 9-24
    - regmerge ..... 9-23
- flash memory ..... 6-2
- flash storage ..... 9-23
- fonts ..... 6-1
  - asian font installation ..... 6-2
  - greek ..... 6-1
  - japanese ..... 6-1
  - korean ..... 6-1
  - russian ..... 6-1
  - simplified chinese ..... 6-1
  - swedish ..... 6-1
- function status ..... 5-7

**G**

- getting started ..... 1-6

**H**

- hard reset ..... 1-12, 1-15
- help ..... 5-9
- humidity ..... A-2

**I**

- information, service ..... xvi
- Initial Program Loader ..... 9-25
- installing development tools ..... 9-2
- IPL ..... 9-25
  - error messages ..... 9-16
  - error screen ..... 9-16

**K**

- key ..... 1-10
- key descriptions
  - two-color alphanumeric ..... 1-6
- keyboard ..... A-1
- keypads ..... xii

**L**

- laser safety ..... A-2
- laser scanning
  - See data capture ..... 1-13
- LED indicators ..... 1-5
- lithium-ion battery ..... 1-1

**M**

- main battery
  - charging
    - temperature range ..... A-3
- maintenance ..... 10-1
- memory ..... xii, A-1
- mobile computer
  - cold boot ..... 9-23
  - starting ..... 1-12

**O**

- operating system ..... xii, A-1
- operating temperature ..... A-2

**P**

- partitions



- downloading ..... 9-25
    - FFS ..... 9-23
    - non-FFS ..... 9-24
      - IPL ..... 9-25
      - splash screen ..... 9-24
  - parts of the mobile computer ..... 1-1
  - pin-outs
    - mobile computer ..... A-4
  - power cable ..... 1-4
  - power settings ..... 6-4
  - power supply ..... 1-4
  - power supply housing ..... 1-4
    - accessories ..... 1-4
  - program menu ..... 5-9
  - programs
    - flash file system ..... 9-23
  - properties ..... 5-10
  - provisioning ..... 2-1
- R**
- radios ..... xii
  - RAM ..... 6-2
  - reset
    - hard ..... 1-12, 1-15
    - soft ..... 1-15
  - resetting ..... 1-15
  - run ..... 5-9
- S**
- scan status ..... 1-14
  - scan status *See also* data capture
  - scanning
    - bar codes ..... 1-13
    - LED indicators ..... 1-14
    - See* data capture ..... 1-13
  - screen
    - Symbol splash screen ..... 1-12
  - scripts
    - creating ..... 9-8
    - saving ..... 9-9
  - service information ..... xvi
  - setting up a partnership
    - partnership ..... 4-3
  - settings ..... 5-9
  - show clock ..... 5-11
  - soft reset ..... 1-15
  - splash screen ..... 9-24
    - creating ..... 9-18
  - staging ..... 2-1
  - start menu ..... 5-9
  - starting the mobile computer ..... 1-12
  - status icon ..... 5-7, 5-8
  - status icons
    - Windows CE 7.0 ..... 5-7
  - storage temperature ..... A-2
  - suspend ..... 5-9
- T**
- taskbar ..... 5-7
  - TCM
    - building hex image ..... 9-5, 9-9
    - creating script ..... 9-8
    - defining properties ..... 9-7
    - error messages ..... 9-14
    - hex image download ..... 9-10
    - saving script ..... 9-9
    - starting ..... 9-5
  - temperature
    - battery charging ..... A-3
  - troubleshooting ..... 10-6
- U**
- unpacking ..... 1-1
  - USB cable ..... 1-4
- W**
- wake up conditions ..... 5-12
  - warm boot ..... 1-15
  - weight ..... A-1
  - WLAN 802.11a/b/g ..... xii
  - WLAN radio ..... A-2
- Y**
- Y-power cable ..... 1-4





***symbol***<sup>®</sup>

Symbol Technologies, Inc.

1301 E. Algonquin Rd.

Schaumburg, IL 60196-1078, U.S.A.

<http://www.motorolasolutions.com>

Symbol<sup>®</sup> is a registered trademark, and The Enterprise Mobility Company is a trademark of Symbol Technologies, Inc. All other trademarks and service marks are proprietary to their respective owners.

© 2014 Symbol Technologies, Inc. All Rights Reserved.

MN000834A01 Revision A - July 2014