



Stationary Reader User's Manual

Published: April 16, 2002
Document Control Number: MNI01H001

Matrics, Inc.
8850 Stanford Boulevard
Suite 3000
Columbia, MD 21045
Tel: 410.872.0300
Fax: 410.872.0700
<http://www.matrics.com>

Notices

Copyright © 2001-2002 Matrics, Inc. All rights reserved.

This document is protected by copyright with all rights reserved. No part of the document may be reproduced or transmitted by any means or in any form without prior consent in writing from Matrics, Inc.

Trademarks

Matrics is a trademark of Matrics, Inc. All other product names or logos mentioned herein are used for identification purposes only, and are the trademarks of their respective owners.

Statement of Rights

IMPORTANT – READ CAREFULLY: Matrics products incorporate technology that is protected by U.S. patent and other intellectual property (IP) rights owned by Matrics, Inc, and other rights owners. Use of these products constitutes your legal agreement to honor Matrics’ IP rights as protected by applicable laws. Reverse engineering, decompiling, or disassembly of Matrics products is strictly prohibited. Violators will be prosecuted.

Contents

SECTION 1. INTRODUCTION	1
Document Conventions	1
Acronyms and Abbreviations.....	1
Disclaimer.....	1
SECTION 2. SYSTEM DESCRIPTION.....	2
Product Description	2
SECTION 3. SPECIFICATIONS AND DIAGRAMS	3
Reader Specification	3
LEDs and Connectors.....	3
Reader Diagram.....	4
Connections Diagram.....	5
SECTION 4. GETTING STARTED.....	6
What's Included?.....	6
SECTION 5. INSTALLATION.....	7
Mount the Reader	7
Connect Antenna(s) to the Reader	8
Connect the Reader to a Host Computer	8
Power On (and Off) the Reader	8
Verify the Reader Installation.....	9
<i>Reader On?</i>	9
<i>Test Read Range</i>	9
SECTION 6. CAUTIONS, NOTES, AND APPROVALS	10
SECTION 7. WARRANTIES AND RETURNS	11
Limited Warranty	11
Return Material Authorization (RMA).....	11
SECTION 8. TROUBLESHOOTING.....	12
SECTION 9. CONTACT US.....	13

This page left intentionally blank.

Section 1. Introduction

This *Stationary Reader User's Manual*, designed for the Matrics RFID System end-user, describes the Stationary Reader (PN: RDR-001) and how to install it.

Document Conventions

The following conventions are used in this *User's Manual*:

CONVENTION	DESCRIPTION
1. Numbered list	Provides step-by-step procedures for performing an action
• Bulleted list	Provides grouped information, not procedural steps

Acronyms and Abbreviations

The following acronyms and abbreviations are used in this *User's Manual*:

ACRONYM	DEFINITION
IC	Integrated Circuit
MVM	Matrics Visibility Manager
OOK	On Off Keyed
RFID	Radio Frequency Identification
TBD	To Be Determined

Disclaimer

While Matrics has committed its best efforts to providing accurate information and timely updates to this *User's Manual*, we assume no responsibility for any inaccuracies that may be contained herein, and we reserve the right to make changes to this *User's Manual* without notice.

Section 2. System Description

Matrics develops and markets Radio Frequency Identification (RFID) solutions that are effective and affordable by offering a combination of low cost, long read range, and a very high read rate unmatched by other RFID systems. A Matrics RFID System gives you real-time, end-to-end visibility of products and assets in your factory, distribution center, retail outlet, or other facility. A typical Matrics RFID system consists of three main components:

- Silicon-based **RFID tags** that can be attached to containers, pallets, boxes, trays, etc., to create a “people-free” wireless environment for tracking objects as they travel through the supply chain,
- **Reader network components** (readers, antennas, cables, connectors, power supplies, etc.) that power and communicate with the tags, and
- The **Matrics Visibility Manager (MVM)** software that runs on your choice of host computer and collects tag data automatically.

Product Description

The **Matrics Stationary Reader** (PN: RDR-001) is an industrial strength fixed Reader targeted to indoor applications, such as warehouses. The Reader offers superior and robust read range capabilities, anti-collision features, and very high data read rates unmatched by other systems. It can be easily mounted in areas of ingress and egress where large numbers of tagged objects are inbound or outbound in a logistics process. It is packaged ready to be interfaced to your host computer, and can easily be programmed to perform specific tasks.

The Reader provides all of the RF and control functions required to power and communicate with Matrics passive RFID tags (PN: SDR-001 and DDS-001.) It sends digital data to the tag (through one antenna at any given time) on a pulse width modulated On Off Keyed (OOK) transmitter signal, demodulates the identification signal received from the tag, and then sends the data to your host computer.

The Matrics Reader network is structured to allow for flexibility in system configurations and in the arrangement of read points to optimize coverage at a low overall cost. In its maximum configuration, a single Reader can support a total of thirty-two (32) lower performance antennas [with eight (8) lower performance antennas attached to each of up to four (4) multiplexers attached to a Reader], or four (4) high performance antennas attached directly to a Reader. Any combination (up to the maximum) of high performance antennas (directly attached to the Reader) and lower performance antennas (attached to the Reader via multiplexers) can be implemented.

The system also employs a unique, patented reader-driven interrogation protocol that allows up to two hundred (200) tags to be read each second. This powerful read rate supplies the muscle to overcome interference in noisy environments, and to guarantee acceptable read rates at each read point when large numbers of antennas are multiplexed together.

Readers can be powered either locally or through the network cable in the event there is not a local power source near by, and to minimize overall network infrastructure costs.

Section 3. Specifications and Diagrams

Reader Specification

CHARACTERISTIC	DESCRIPTION	
Name/Part Number	Stationary Reader (PN: RDR-001)	
Operating Frequency	UHF band, 902-928 MHz, frequency hopping	
System Architecture	Point-to-multipoint reader network	
Dimensions	12.5" wide (includes mounting plate) x 8.75" high (includes connectors) x 1.5" deep	
Simultaneous Reading Capability	Up to 200 tags per second	
Temperature	Operational: 0° to +50° C (+32° to +122° F) Storage: -20° to +70° C (-4° to +158° F)	
Communications Interface	RS485, 232400 bps, no flow control, no parity, 8 data bits, 1 stop bit	
Input/Output	4 dual coax antenna mini-UHF connectors, 1 RJ45 host comm., 1 2.5 mm power, 1 RJ14 multiplexer	
Power Supply	+24 VDC, 1.2A (unregulated)	
Power Consumption	30 watts operational, 1 watt standby	
RJ45 Pin Assignments (host communications)	Pin 1: Tx+ Data Pin 2: Tx- Data Pin 3: Power Return and Ground Pin 4: +24VDC	Pin 5: +24VDC Pin 6: Power Return and Ground Pin 7: Rx- Data Pin 8: Rx+ Data
Multiplexer connection	Pin 1: Clock+ Pin 2: Clock- Pin 3: +12V	Pin 4: +12V Pin 5: Tx- Data Pin 6: Tx+ Data

LEDs and Connectors

ITEM	DESCRIPTION
Power/Activity LED	LED is red when the Reader is powered on and receiving power. The light blinks when commands are correctly received from the host PC.
RS485 / Bus Power Connector	Connect to host PC and bus power.
RJ14 Connector	<i>For future use.</i>
+24VDC 1.2A Connector (Unit Power)	The power supply should be plugged into a wall outlet and into the DC power connector.
Mini-UHF Antenna Connectors	Connect to external antennas.

Reader Diagram

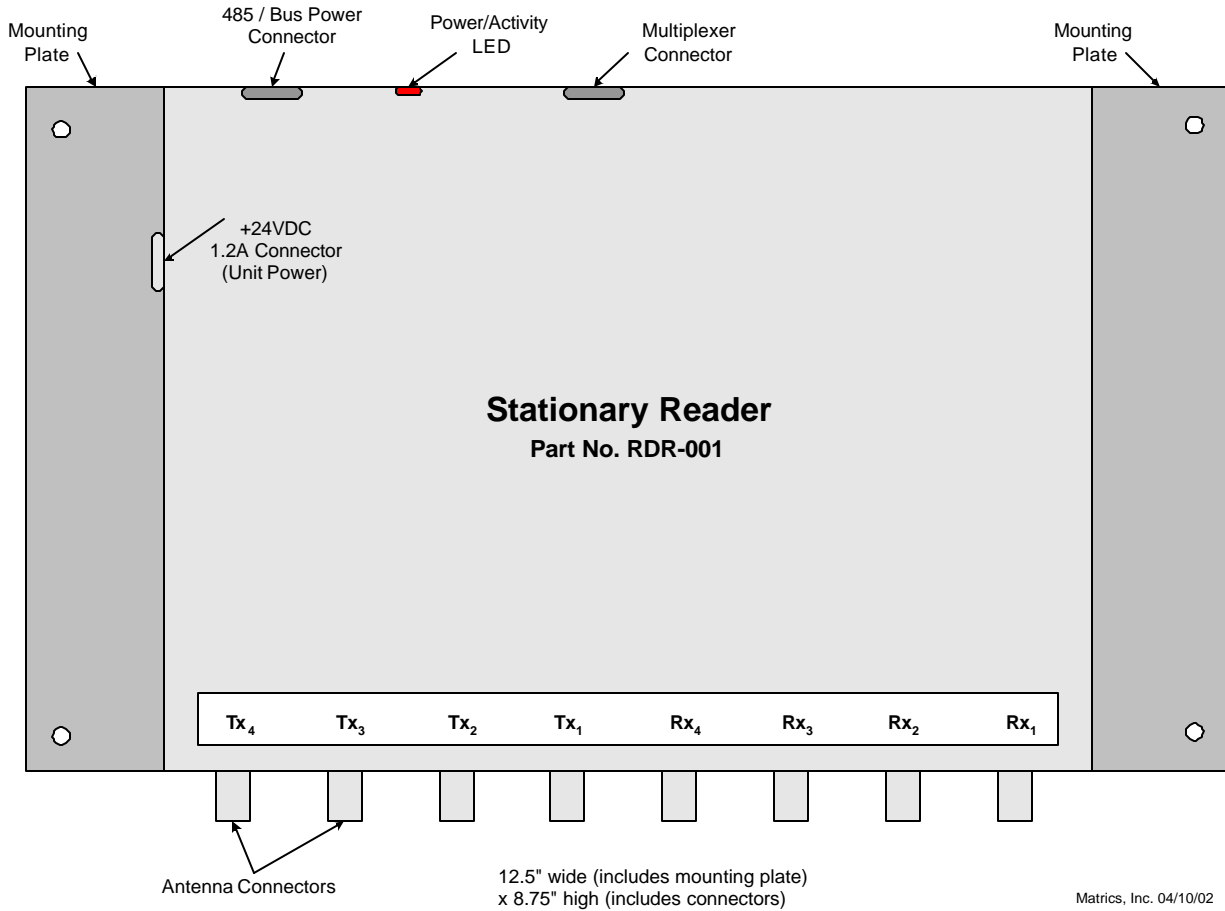

Connections Diagram

Functional System Connections

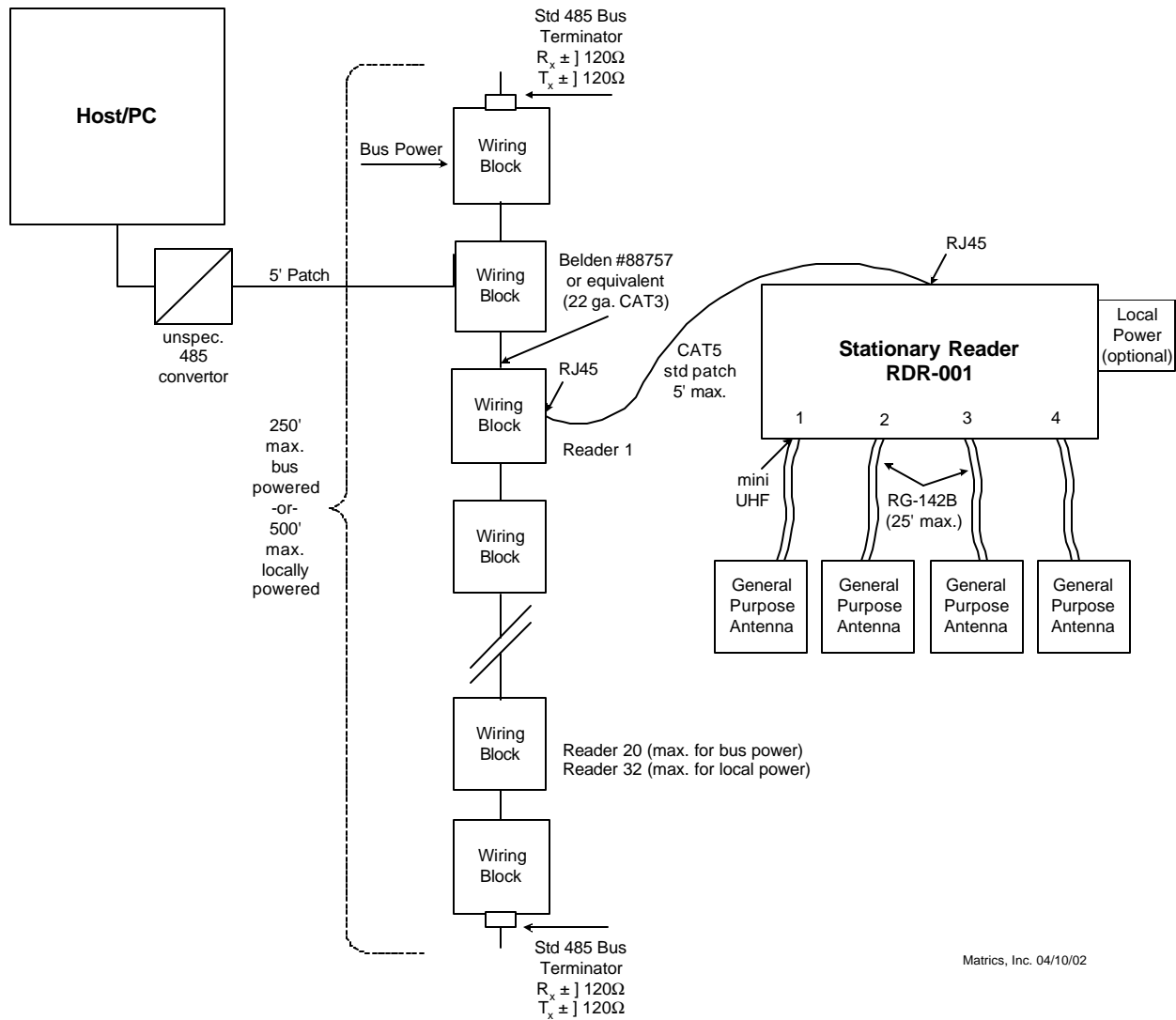

Section 4. Getting Started

What's Included?

Before you proceed with your Reader installation, check that you have all of the items you need. Contact Matrics (refer to the "Contact Us" section in this *User's Manual*) if any of the parts listed in this section are missing from your Reader package, or any of the items you received are damaged.

NOTE: You should use ONLY those parts provided in your Reader package or specifically recommended by Matrics. Do not substitute any other cables, etc., since doing so may degrade your system's performance, damage your Reader, and void your warranty.

In addition to this *User's Manual*, you should have received the following items in your package:

PART NUMBER (PN)	QTY.	DESCRIPTION	
RDR-001	1	Stationary Reader	
	1	CAT3 cable termination block ("wiring block")	
	1	3-foot data cable	

In addition, you will need:

- Matrics Reader Networking Kit (PN: NKT-001) to connect the Reader to your host computer,
- A power supply for your Reader (such as PN: PWR-001, available from Matrics),
- (4) screws for mounting the Reader, and
- several wire ties to secure any extra lengths of cable.

Section 5. Installation

Follow the steps listed below (and detailed in the following sections) to install, configure, and test your Reader:

1. Mount the Reader in a location chosen for optimal surveillance.
2. Connect antenna(s) to the Reader.
3. Connect the Reader to your host computer.
4. Power on the Reader.
5. Verify that your Reader installation is operational.

Mount the Reader

Before mounting the Reader, you must select a location for it. For best results, consider the following when determining the optimal placement for your Reader:

- Mount the Reader indoors, in operating range, and out of direct sunlight, high moisture, or extreme temperatures.
- Mount the Reader in an area free from electromagnetic interference. Such sources of interference may include: generators, pumps, converters, non-interruptible power supplies, AC switching relays, light dimmers, computer CRT terminals, etc.
- Mount the Reader within 15 feet of your antennas (antenna connector cables from Matrics are 15-feet long.)
- Make sure the local power supply cord, when attached to the Reader, can reach the power source outlet.
- Do not mount the Reader within 12 inches of a computer CRT terminal.
- Make sure that you will be mounting the Reader onto a permanent fixture (wall or shelf) where it won't get disturbed, bumped, or damaged. Keep in mind that you will need five (5) inches of clearance on all sides of the Reader.

CAUTION: If the Reader is not installed properly, it could be damaged and your system performance diminished.

To mount the Reader:

1. Position the Reader (PN: RDR-001) at the desired mounting position on the wall or shelf. Make sure that there are five (5) inches of clearance on all sides of the Reader.
2. Using the pre-drilled holes at the corners of the Reader to guide you, drill four holes for mounting the reader.
3. Securely affix the Reader to the wall of shelf using the four screws that you provided.

Connect Antenna(s) to the Reader

Attach your antenna(s) to the Reader in sequential order (first connecting Antenna 1 to Reader connectors Tx₁ and Rx₁, then Antenna 2 to Reader connectors Tx₂ and Rx₂, Antenna 3 to the Tx₃/Rx₃ connectors next, and Antenna 4 to the Tx₄/Rx₄ connectors last.)

1. Attach the large ends of your antenna connector cables to the large connectors on the antenna.
2. Attach the small ends of the cables to the corresponding connectors on the Reader (Antenna 1 to Reader connectors Tx₁ and Rx₁, etc.)
3. Secure your cables using wire ties (do not bend the cables.)

WARNING: Do not disconnect antenna cables when actively reading tags (if the LED is lit on the Reader, don't disconnect the antenna cables.) You could severely damage your Reader. Make sure that you unplug the power supply to power off the system first before disconnecting cables.

Connect the Reader to a Host Computer

The steps you must follow to interface the Reader with your system depend upon the software package you choose to use. Contact Matrics for more information.

Regardless of the software you use to do it, you must change your Readers' factory-assigned xFF address to a unique address for communicating with your host computer.

Power On (and Off) the Reader

1. Connect a 24V DC power supply (such as PN: PWR-001, available from Matrics) to the Reader's Unit Power port.
2. To power on the system, insert the plug end of the power supply into a 24V ($\pm 1V$) / 40W power outlet. The Power/Activity LED on the Reader should light red, indicating that the Reader is powered on and the system is live.

-
3. To power off the Reader, unplug the power supply from the power outlet. The Power/Activity LED on the Reader should turn off, indicating that the Reader is powered off and the system is not operational.

Verify the Reader Installation

Reader On?

After you have installed the Reader as described in this *User's Manual*, test that the Reader is on by following the instructions provided above in the "Power on (and Off) the Reader" section.

To verify that the Reader is operational, power it on by plugging the power supply (attached to the Reader) into the appropriate power outlet. The Power/Activity LED on the Reader should light red, indicating that the Reader is powered on and the system is operational.

Test Read Range

After you have installed the Reader as described in this *User's Manual*, test the read distance of your hardware configuration to verify that it meets your needs.

1. To measure the read distance between the Reader and a tag, hold a tag in front of you (with the tag face parallel to the Reader face.)
2. Walk slowly toward the Reader until the Reader responds with a flash of the Power/Activity LED. This indicates that the Reader has detected and read the tag.

NOTE: For purposes of this test, we recommend that you do not hold the tag at an angle, or wave the tag in front of the Reader, as that may cause the measured read distance to vary.

3. In order to read the same tag again, first remove the tag completely from the Reader's read field, and then perform Step 2 again.

Section 6. Cautions, Notes, and Approvals

Matrics products are approved (or approval pending) by the appropriate regulatory agencies:

- Federal Communications Commission (FCC), Part 15
- Underwriter Laboratory, UL 294

Note: This equipment has been tested and found to comply with the limits for a Class A digital device, pursuant to Part 15 of the FCC Rules. These limits are designed to provide reasonable protection against harmful interference when the equipment is operated in a commercial environment. This equipment generates, uses, and can radiate radio frequency energy and, if not installed and used in accordance with the *User's Manual*, may cause harmful interference to radio communications. Operation of this equipment in a residential area is likely to cause harmful interference in which case the user will be required to correct the interference at his or her own expense.

CAUTION: Changes or modifications not expressly approved by the party responsible for compliance could void the user's authority to operate the equipment.

Information to the User: This device complies with Part 15 of the FCC Rules. Operation is subject to the following two conditions: (1) This device may not cause harmful interference, and (2) This device must accept any interference received, including interference that may cause undesired operation.

WARNING: This device must be installed in a location that is not accessible to the general public. Install the device so that the antenna is at least 25 centimeters from unsuspecting personnel. Failure to install this device as described will result in a failure to comply with FCC rules for RF exposure and is discouraged.

Disclaimer: Operation of any radio transmitting equipment, including this product, may interfere with the functionality of inadequately protected medical devices. Consult a physician or the manufacturer of the medical device if you have any questions. Other electronic equipment may also be subject to interference.

Section 7. Warranties and Returns

Limited Warranty

Matrics warrants its products to the original purchaser to be free of defects in workmanship and material for a period of ninety (90) days from date of receipt. Matrics' sole and complete responsibility under this warranty is expressly limited to repair or replacement of the defective product.

Replacement products may be new or reconditioned. All products that are replaced shall become the property of Matrics. The warranty for replacement products is the same as the equivalent newly purchased product.

Any tampering or modification to the product, or subjecting of product to abnormal electrical, mechanical, or environmental abuse will void this product warranty.

Return Material Authorization (RMA)

You must obtain a return material authorization (RMA) number from Matrics Customer Service (refer to the "Contact Us" section in this *User's Manual*) before you return any parts for repair or replacement. This RMA number must be clearly marked on the outside of the returned package, and referenced in any correspondence contained within the package.

NOTE: If you return parts to Matrics without a RMA number, they will be returned to you at your own expense.

Before you call Matrics to receive a RMA number, make sure that you have the following information available for the Customer Service technician:

- A description of the returning item.
- Serial numbers (if applicable.)
- A description of the fault or failure. (Example: The antenna cable appears to have been pulled out of the antenna, and the system is not functioning.)
- Fault or Error message (if applicable.)

Section 8. Troubleshooting

In the event that you encounter a problem with your system, refer to the following table for possible solutions:

PROBLEM	POSSIBLE CAUSE	SOLUTION
The Reader's Power/Activity LED doesn't light.	The AC outlet may not be working or may be controlled by a wall switch.	Plug a different electrical appliance into the outlet and turn it on. If the appliance doesn't work, plug the Reader into a different outlet.
The Reader's Power/Activity LED is on but doesn't blink.	The Reader isn't communicating with the host PC -or- The host PC isn't communicating with the Reader.	Check that your host PC's port settings are configured properly. Make sure that you used the Utility software to change the Reader's factory-assigned xFF address to a unique address for communicating with your host PC. Check to ensure proper network cabling (including terminators at both ends.) Verify communications at a fixed 230,400 rate.
Read range has degraded noticeably.	The environment may not be free from sources of electromagnetic interference.	Check that your Reader is installed in a location free from electromagnetic interference sources such as: generators, pumps, converters, non-interruptible power supplies, AC switching relays, light dimmers, computer CRT terminals, etc. Run system cabling away from other data carrying cables.

Section 9. Contact Us

For sales, service, and technical assistance, contact Matrics at:

Tel: 410.872.0300

Monday-Friday 8:30 a.m. – 5:00 p.m. EST

Fax: 410.872.0700

<http://www.matrics.com/>

Matrics, Inc.

8850 Stanford Boulevard

Suite 3000

Columbia, MD 21045

USA