

SYMEO LPR®



SYMEO

ABSOLUTE POSITIONING

Product Documentation

Product: BSB00056 LPR-1D

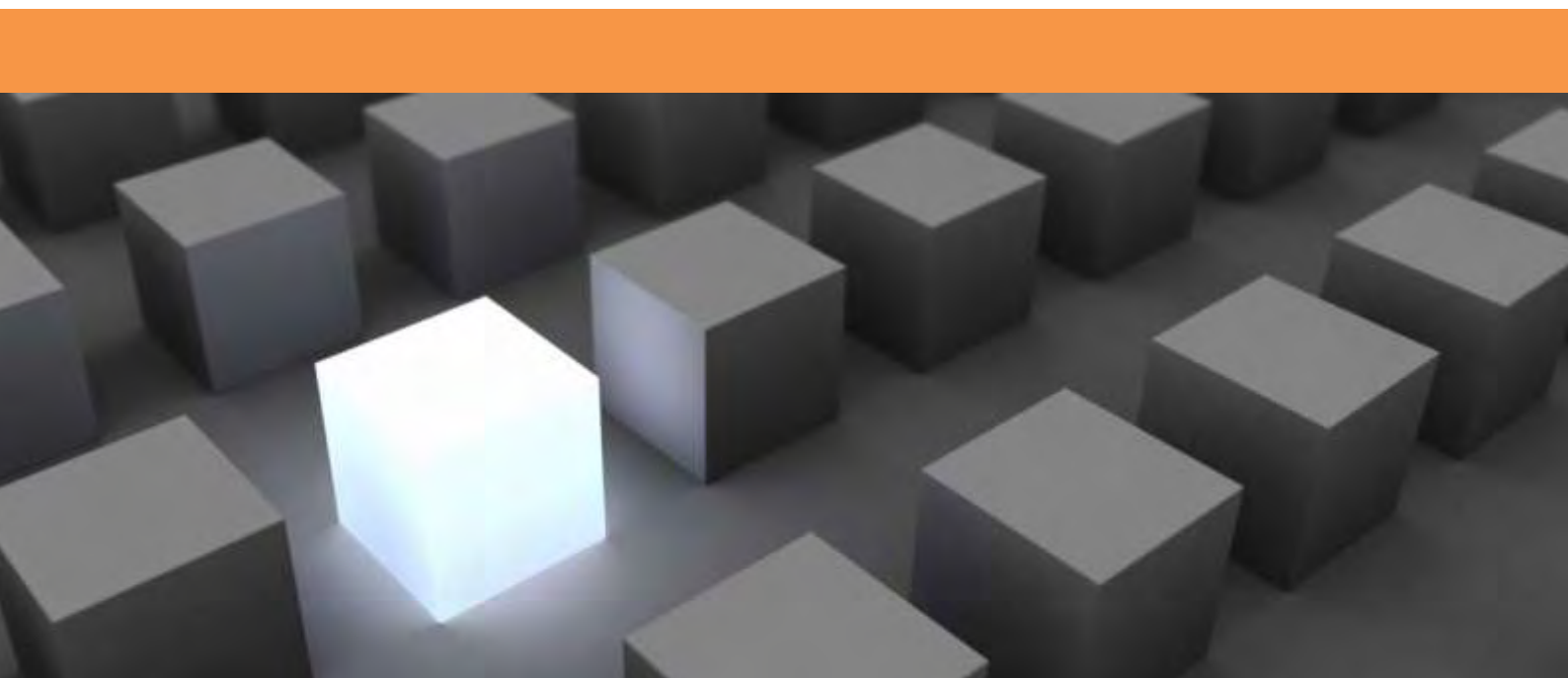

CONTENT

1	OVERVIEW	6
1.1	Safety Instructions	7
1.2	Installation	7
1.3	Repairs	7
1.4	Transport and Storage	8
1.5	Power Supply	8
1.6	Setup and Operation	8
1.7	System Extensions and Accessories.....	9
1.8	Additional Instructions Regarding Compact Type and Integral Type Stations....	9
2	SYSTEM DESCRIPTION	10
2.1	System architecture	10
2.2	Technical Data	10
2.3	System Configuration	11
2.4	System Design.....	11
2.4.1	Station-ID (SID)	11
2.4.2	Group-ID (GID).....	12
2.4.3	FSK Channel (FSK).....	12
2.5	Mode of Operation of the System.....	13
2.6	Application Examples	14
2.6.1	Redundant arrangement (2xLPR-1DX).....	14
2.6.2	Positioning of Crane Crab (LPR® 1DP2).....	15
2.6.3	Positioning of 2 Cranes on two Runways (LPR® 1DP)	16
3	HARDWARE	17
3.1	LPR® Station (Design Compact Station)	17
3.1.1	PIN-Assignment of Lumberg Type 0233 08 (Power Supply, RS232-Interface).....	19
3.1.2	PIN-Assignment of Lumberg Typ 0233 14 (Relays)	20
3.2	Cables for LPR® Station	20
3.2.1	Assembled Cable for power supply and service port.....	20
3.2.2	Assembled Cable for relays	22
3.2.3	Ethernet Cable.....	23

3.3	LPR® Connection Box	24
3.3.1	Example Connector Box	25
3.4	LPR® Antenna Types	27
3.4.1	Adapter for different LPR® Antennas.....	28
4	INSTALLATION	30
4.1	Installation of LPR® Station Design Compact Station.....	30
4.1.1	Important Instructions for Installation	30
4.1.2	Installation	30
4.2	Installation of LPR® Antennas	30
4.2.1	Connecting and Wiring up the Antenna and Cable	30
4.2.2	Installing the Antenna(s)	31
4.2.3	Fresnel zone.....	32
4.2.4	Installation of Planar Antennas	33
5	COMMISSIONING.....	33
5.1	Requirements.....	33
5.1.1	General.....	34
5.2	Connection to LPR® Station with TCP/IP Interface.....	35
5.3	Connection LPR® Station with serial Interface	36
5.4	Commissioning Tool – LPR® 1D Wizard.....	38
5.4.1	Installation	38
5.4.2	Utilization of LPR® 1D Wizard	39
6	WEB SERVER.....	48
6.1	Open Web Server.....	48
6.2	Settings	49
6.2.1	„LAN“ area	50
6.2.2	„Network“ Area	50
6.2.3	„Serial-to-Ethernet“ Area.....	51
6.2.4	„Remote Access“ Area.....	53
6.2.5	„Miscellaneous“ Area	54
6.2.6	„Special Functions“ Area	54
6.2.7	Accept settings / System Reboot	55
6.3	System Status.....	56
6.4	Diagnostics	57
6.5	Update Firmware	58
6.5.1	Step 1 – File system	59
6.5.2	Step 2 – Linux Kernel	61

6.5.3	Step 3 – Optional: Userspace	63
6.5.4	Step 4 – Restart.....	63
6.6	System Log	64
7	PROTOCOL XP DESCRIPTION	66
7.1	General Description.....	66
7.1.1	Direction of Data.....	66
7.1.2	Structure of Data Packet.....	66
7.1.3	Byte Stuffing	67
7.1.4	CRC	67
7.2	Data Types	68
7.2.1	Type 0x00 – Distance Data.....	68
7.2.2	Example of Distance Data	69
7.2.3	Type 0x01 – User Data.....	70
7.2.4	Type 0x02 – Send Request	70
7.2.5	Type 0x03 – Relays Switching Command.....	70
7.2.6	Type 0x04 – 6 Channel Distance Data Set	71
7.2.7	Type 0x05 –Coordinates of cell	72
7.2.8	Type 0x06 – Automatic Calibration	73
7.3	TCP/IP option: Fixed Frame Protocol.....	73
7.3.1	Detailed description TCP Fixed-Frame Protocol	74
7.4	Remarks	74
7.4.1	LPR® Address.....	74
7.4.2	Error messages	75
8	APPENDIX A: AGENCY CERTIFICATIONS	76
8.1	United States (FCC) and Canada (Industry Canada)	76
8.2	United States (FCC).....	76
8.3	Canada (Industry Canada)	77

The documentation for the LPR® System is published by:

SYMEO GmbH
Prof.-Messerschmitt-Str. 3
85579 Munich
www.symeo.com

If you have any questions or suggestions, please contact:

Thies Brauckmann
Email: thies.brauckmann@symeo.com
phone: +49 89 660 7796 210

Copyright © Symeo GmbH 2007
All rights reserved

HISTORY

Overview		
3.17	14.12.2008	New Layout
3.18	11.02.2009	Added all single documents to one master document
3.19	30.03.2009	Added notes for FCC/IC conformity

SYMBOLS USED

The following symbols are used throughout the documentation:



This symbol appears before instructions that must be followed at all times. Failure to comply with these instructions will result in personal injury.

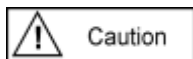

This symbol appears before instructions that must be followed at all times. Failure to comply with these instructions will result in damage to equipment.

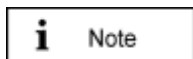

This symbol appears before information of particular importance.

All rights reserved, particularly those relating to the translation, reprinting, and reproduction by photocopying or similar processes of all or part of the documentation.

All rights reserved, particularly for purposes of the award of patents or submission of utility models.

Delivery options and technical changes reserved.

Published by SYMEO GmbH

1 Overview

SYMEO Industrial LPR® is a system for contactless, real-time determination of distances and positions.

LPR® 1D is a distance measurement system which is particularly well suited for use in very harsh, industrial environments, in which other systems such as mechanical rotary encoders or lasers cannot function for long periods.

The Local Positioning Radar System LPR® 1D consists of equal components, which are configured as (depending on customer's application):

LPR® Base Station or LPR® Transponder



Figure 1 – LPR® hardware: transponder or base station in the design “Compact Station”

The difference is between a LPR® 1D transponder and a LPR® 1D Base Station is only the software but not the hardware. A LPR® 1D system consist exactly of one component transponder, named below also as station 1 or as coordinator. And it consists furthermore of one to four LPR® 1D components Base Station, subsequent named station 2, 3, 4, 5.

Depending on customer's application the LPR® 1D hardware has different interfaces. The station in the design compact station has IP65 protection.

Overview	
Antenna Interfaces(1)	2, 3 or 4
Power Supply	10-36 Volt via 8-Pin Lumberg Connector
RS232	Configuration and Data Interface
TCP/IP	Optional: Configuration and Data Interface
Relay	Optional: 7 Dry Contacts

⁽¹⁾ For FCC/IC authorization only LPR® stations with 2 antenna interfaces are allowed to use.

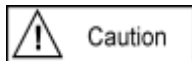

In special application cases it is also possible to get a LPR® station with an integrated antenna. This hardware is called LPR® design "Integral Station" compared to the hardware LPR® 1D design "Compact Station".



Figure 2 – LPR® Hardware – Special Case: Transponder or Base Station with integrated antenna in the design "Integral Station"

The LPR® 1D Station with an integrated antenna is available in a plastic housing. An installation description is delivered separately to this document.

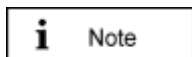

This antenna is not approved to be in compliance with part 15 of FCC rules and with RSS-210 of Industry Canada. Usage of these antennas may void the FCC/ IC authorization to operate this equipment. Further information is found in the Appendix.

1.1 Safety Instructions



LPR®-B systems are purely tracking and assistance systems. They therefore do not satisfy the safety class 3 requirements and must not be used as standalone systems in safety-critical applications, such as automation or anti-collision.

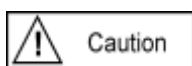

Follow the safety instructions in the operating instructions for the device and the additional documentation!

Keep these safety instructions and other documents together with the device.

1.2 Installation

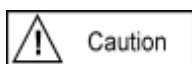

All installation, repair and servicing work must be carried out by qualified and trained technicians!

1.3 Repairs

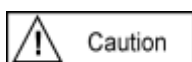

Repairs to the device must be carried out by authorized technicians. Unauthorized opening and incorrect repairs could result in severe danger to the user (danger of electric shock, radiated energy, fire hazard).

1.4 Transport and Storage

 Note

Use the original packaging or other suitable packaging for returns and whenever the system is to be transported. This ensures protection from crushing, impacts, moisture and electrostatic discharge.

During setup and before operation, refer to the instructions for environmental conditions included in the operating instructions for the device.

Route the wires in such a way that they do not cause a hazard and are not damaged. When connecting the wires, refer to the corresponding instructions in the operating instructions for the device.

Do not drop the device and do not expose it to strong vibrations.

1.5 Power Supply

 Caution

A safety-inspected power cable that satisfies the regulations of the country of use is required for the device. Devices with metal housings must only be connected to a grounded, shock proof socket.

The device must not be operated unless the nominal voltage of the device matches the local supply voltage. Check the supply voltage of the device in stationary devices.

Connecting and disconnecting wires refer to the instructions in the operating instructions for the device.

Do not use any damaged wires (damaged insulation, exposed wires). A faulty wire poses a risk of electric shock or fire hazard.

1.6 Setup and Operation

 Caution

During installation, make sure that no objects or fluids get inside the device (risk of electric shock, short circuit).

In emergencies (e. g. if there is damage to the housing, control elements or the mains cable, if fluids or foreign bodies have infiltrated the equipment), switch off the power supply to the device immediately and notify your SYMEO Service.

Protect the contacts of all of the device's sockets and plugs from static electricity. Do not touch the contacts. If it is ever necessary to touch the contacts, take the following precautionary measures: Touch a grounded object or carry a ground strap before touching the contacts. This will divert static charges.

Proper operation (in accordance with IEC60950/EN60950) of the device is only assured if the housing and integral covers for mounting slots are fully installed (electric shock, cooling, fire protection, noise suppression). If necessary, refer to the corresponding instructions in the operating instructions for the device.

In the case of high outside temperatures and intense, direct solar radiation or other radiant heat, it may be necessary to provide a sun or heat shield.

1.7 System Extensions and Accessories

i Note

Data links to peripheral devices must be provided with adequate shielding.

For LAN cabling, the requirements in accordance with EN 50173 and EN 50174-1/2 apply. Use of either a Category 5 shielded cable for 10/100 Ethernet or Category 5e shielded cable for gigabit Ethernet is a minimum requirement. The specifications of standard ISO/IEC 11801 must be complied with.

The warranty shall be voided if you cause defects to the device by installing or exchanging system extensions.

i Note

For FCC/IC compliance: Ethernet cables must be equipped with a ferrite core near the TCP/IP interface at the LPR® station. Otherwise this device may not operate correctly and will not be in compliance with part 15 of FCC rules and with RSS-210 of industry Canada.

1.8 Additional Instructions Regarding Compact Type and Integral Type Stations

 Caution

The Compact type LPR® station must not be opened except for installation. The Compact station contains no serviceable components.

When opening, ensure that no fluid gets into the housing. When sealing the station, ensure that the seal is included in the cover and that the Compact station is completely closed. Otherwise, moisture can penetrate the station and damage it.

In order to install the Integral type LPR® station, the hood must be detached from the serviceable components. Refer also to the instructions on installing the transponder.

Please take note of the safety and operating instructions in the operating instructions for the system in which you want to install the component.

2 System Description

2.1 System architecture

SYMEO Industrial LPR® is a system for contactless, real-time determination of distances and positions.

LPR® 1D is a distance measurement system which is particularly well suited for use in very harsh, industrial environments, in which other systems such as mechanical rotary encoders or lasers cannot function for long periods.

All devices have a unique identifier, via which they are actuated. In order to measure the signal transit time and thus also a corresponding distance, the two devices involved are time-synchronized (with accuracy in the picoseconds range).

LPR® units use the same frequency band and the same hardware for communicating as for measuring distance. This means that no external WLAN or cable networks are needed for transmitting measurement values and other reference data.

2.2 Technical Data

Overview: Technical Data	
Frequency range	5.725-5.875 GHz
Transmitted power *1	Max. 0.008 W / 9 dBm output on the antenna port Output power is adjustable For overall output power antenna gain and cable attenuation must be added, see chapter 6 for details.
Range *2	Max. 1800 m
Measurement accuracy *2	± 5 cm
Measurement frequency *3	Max. 30 Hz
Power supply	10-36 V DC
Ambient temperature *4	-40°C to +70°C

*1 Transmitted power/ field strength can be adjusted to assure that emission limits at the antenna are within legal limits, e.g. 25 mW EIRP in the EU and 50 mV/m at a distance of 3 m in the US and Canada. For FCC /IC authorization the maximum field strength is limited by firmware.

*2 Depending on the antenna type, mounting position and environment

*3 For FCC/IC authorization a maximum measurement frequency of 10 Hz is allowed.

*4 Temperature inside the housing can range from -40°C to 85°C.

2.3 System Configuration

The LPR® 1D system consists of two, three, four or five LPR® units. Each of these units can be configured either as a transponder or as a base station. A system consists of exactly one LPR® unit configured as a transponder and between one and four LPR® units configured as base stations.

For pure 1D distance measurement two units are required and are arranged as shown in Figure 3. The distance information is available at both stations.

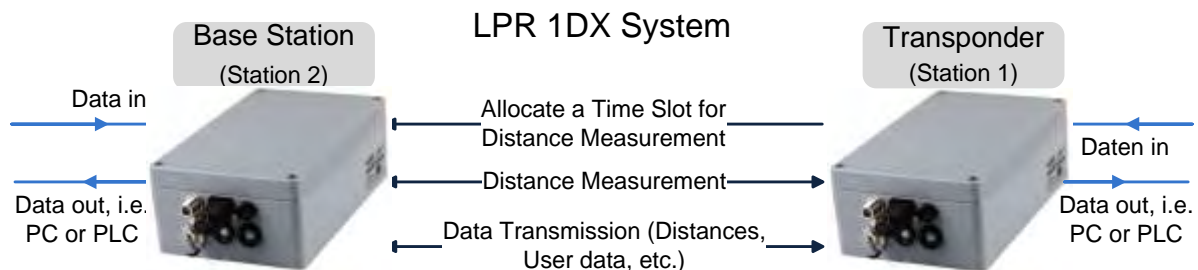

Figure 3: 1D system

Besides the distance information, smaller volumes of user data can also be passed between the units. These are fed in on the serial port of a unit and output in corresponding manner on the other side.

Each unit consists of a basic unit, corresponding antenna cable, antenna, as well as power supply and ports.

Further options for arranging LPR® units are described in the section 2.6 "Application Examples".

2.4 System Design

Each LPR® 1D station has parameters to provide an explicit allocation to a system and also to ensure the functionality of a system. These parameters are explained in the following:

2.4.1 Station-ID (SID)

Each station has an explicit Identification Number in one system. If using more than one LPR® 1D systems in your environment same station numbers could be used. BUT: In one system all station numbers are different.

A system consists at least of 2 stations, at most of 5 stations. The first station has the station number 1 (SID 1), die second station has the station number 2 (SID 2), etc.

Station 1 (SID 1) is the LPR® Transponder, also known as the coordinator of the system. Stations 2 – 5 (SID 2-5) are LPR® Base Stations. A transponder (SID 1) can only measure with a base station (SID 2 – SID 5) and vice versa, but NEVER with another transponder or a base station with another base station. But the transponder (coordinator) can measure with up to 4 base stations.

Keep in mind:

Station 1	Transponder
Station 2	Base Station
Station 3	Base Station
Station 4	Base Station
Station 5	Base Station

i Note

The hardware of a transponder and base station looks like the same. The only difference is the configuration software. The transponder organizes the measurements. It allocates time slots to the base stations to identify when these stations are allowed to start with a measurement.

2.4.2 Group-ID (GID)

A system is identified clearly by its group number. All stations in one system have the same group number. If there is used a second, a third or more systems in your environment, all additional systems must have then a different group number (see Figure 5).

2.4.3 FSK Channel (FSK)

The measurement of the round trip of flight (RTOF) happens in a frequency band width of 5,725 to 5,875 GHz. In this band width the LPR® system gets a frequency channel. 18 frequency channels are available. All stations in one LPR® systems have the same frequency channel.

 Caution

If there are more LPR® systems in your environment each further LPR® system has another frequency channel (see Figure 5).

i Note

If you commission the system with the LPR® commissioning tool LPR® 1D Wizard you cannot choose the frequency channel. The frequency channel is linked to a group ID. Therefore it is really important to use different group IDs for different LPR® systems.

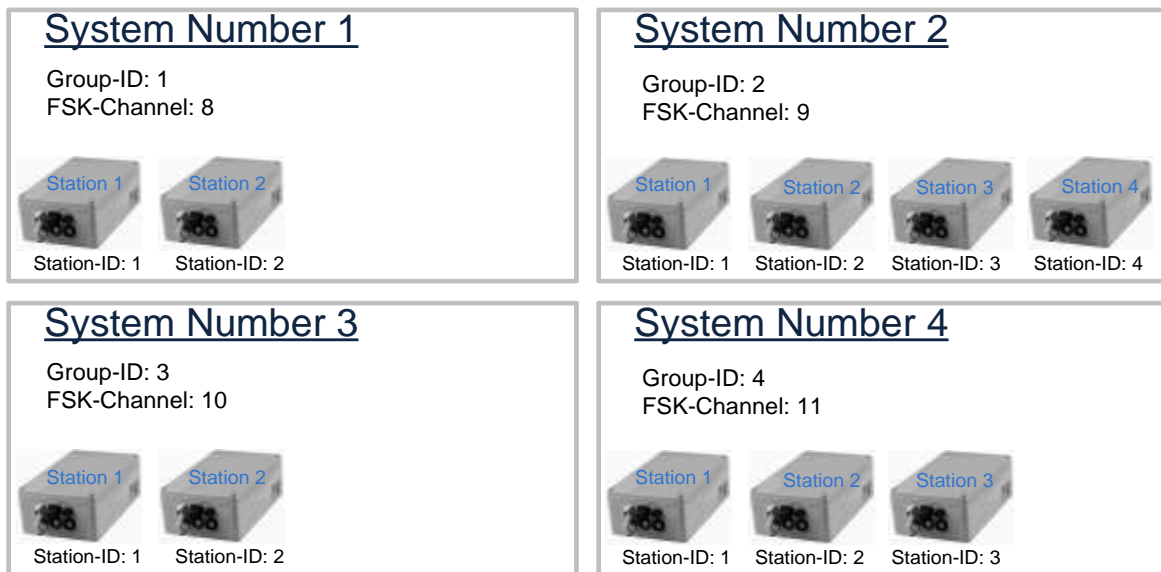

Figure 4 – Example of the relation Station-ID, Group-ID und Frequency Channel

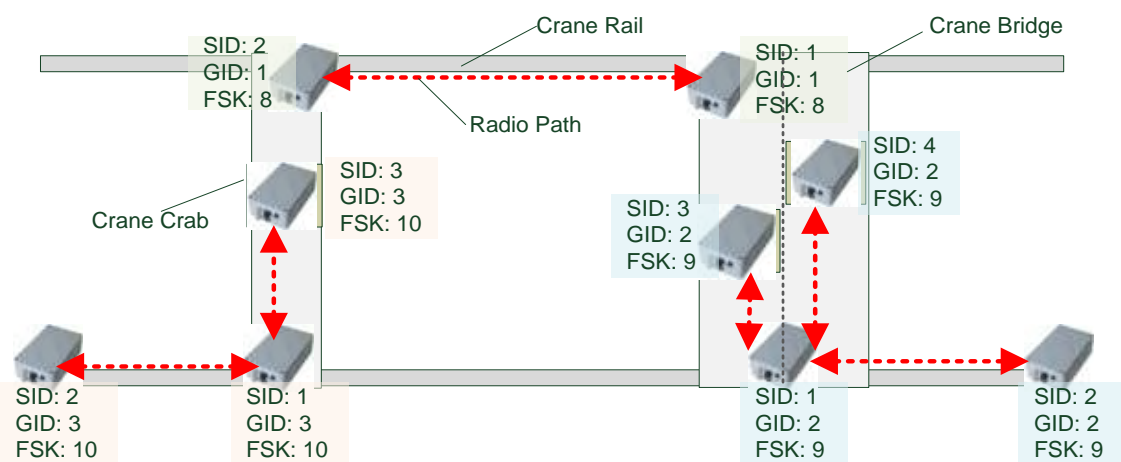

Figure 5 – Example of multiple LPR®-systems in one crane environment

2.5 Mode of Operation of the System

The distance is determined by measuring the transit time of radio signals. For this, the transponder unit first sends a communication packet to the base station that is to carry out the measurement. The station that is addressed in this way sends a response sequence and a special, wideband response signal which is ideal for making distance measurements. The transponder synchronizes itself with this signal and after a precisely known time replies in highly synchronized manner with exactly the same signal. The base station receives this signal and uses the signal transit time to determine its distance from the transponder.

The distance can be output after the measurement by any of the units participating. As an option, if the distance falls below a given value, a switch (dry contact) can be actuated to trigger a warning signal, for example.

Besides distance measurement, the system's communication can be used for transmitting user data in the intervals between measurements. Transmission is asynchronous, i.e. the data is requested and transmitted when the measurement has been completed. To transmit data over the system, first a send data request is sent by the LPR® unit to the user. Then the user data is received and transmitted to the second LPR® station. The data channel has a channel capacity of 8byte/measurement cycle. This means, the overall capacity depends on the chosen measurement frequency. I.e. if a measurement frequency of 10Hz is chosen, the capacity is 80 byte/s

2.6 Application Examples

Figure 3 in shows the simplest arrangement of LPR® units (LPR® 1DX). This is used for measuring the distance between two LPR® units. The abbreviation means distance measurement without positioning.

Some more complex arrangements are illustrated in the following text.

2.6.1 Redundant arrangement (2xLPR-1DX)

For reasons of operational safety, it may be necessary to combine two systems in a redundant arrangement. Figure 4 shows two base stations and two transponders installed in a redundant arrangement on two crane bridges. Each base station communicates with the opposite transponder. Both systems measure independently from each other. After the measurement, the distance from the respective partner can be output at each of the participating stations. Optionally, a switching contact may also be actuated depending on the distance, e.g., to trigger a warning signal for example if the crane bridges come too close to one another and there is a danger that they may collide.

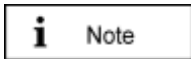

If more than one LPR® system is used, each system has its own group ID and its own frequency channel. So both systems do not disturb each other.

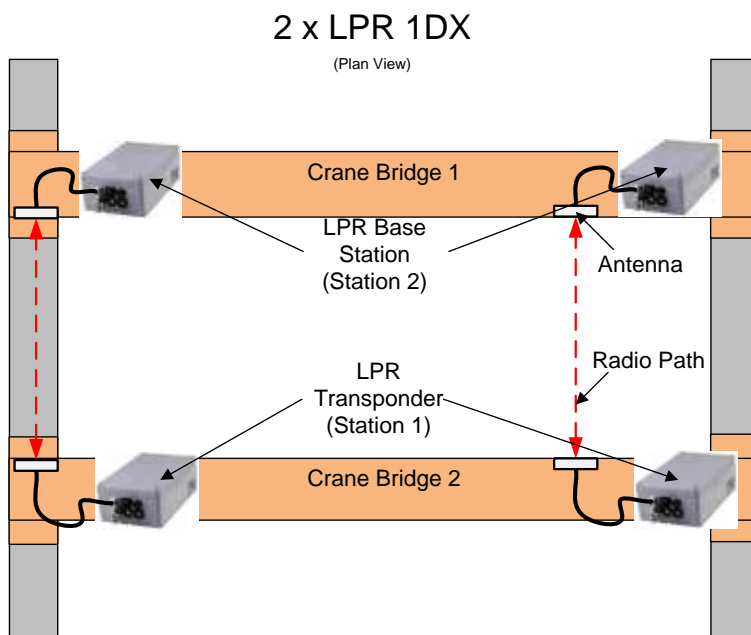

Figure 6: LPR® 1DX Redundant arrangement

2.6.2 Positioning of Crane Crab (LPR® 1DP2)

In order to determine positions in two dimensions (x-y coordinates), three LPR® units can be arranged in an L-shape (see Figure 7). In this case, the unit that is configured as the transponder (station 1) is equipped with 2 antennas. This unit measures against the first base station (station 2) with the first antenna, and against the second base station (station 3) with the other antenna, for example. In this way, the position of a crane crab can be determined, for example.

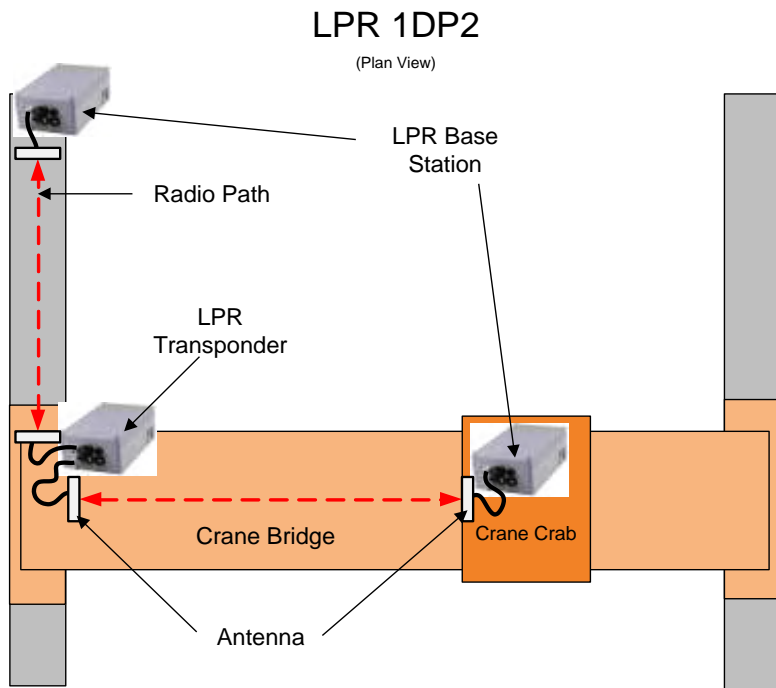

Figure 7: LPR® 1DP2 L-shaped arrangement

2.6.3 Positioning of 2 Cranes on two Runways (LPR® 1DP)

The Y-shaped arrangement can be used to determine the position of two cranes on different crane runways, for example. In the arrangement shown in Figure 8, the transponder unit (station 1) is equipped with two antennas. One base station (station 2 and station 3) is installed on each of the two cranes. The two antennas are secured to the wall at the same height as the respective base stations installed on the cranes. In this way, the distance of both cranes from the wall can be calculated. By comparing these two distances, a warning may be output before the two cranes cross each other's path, for example.

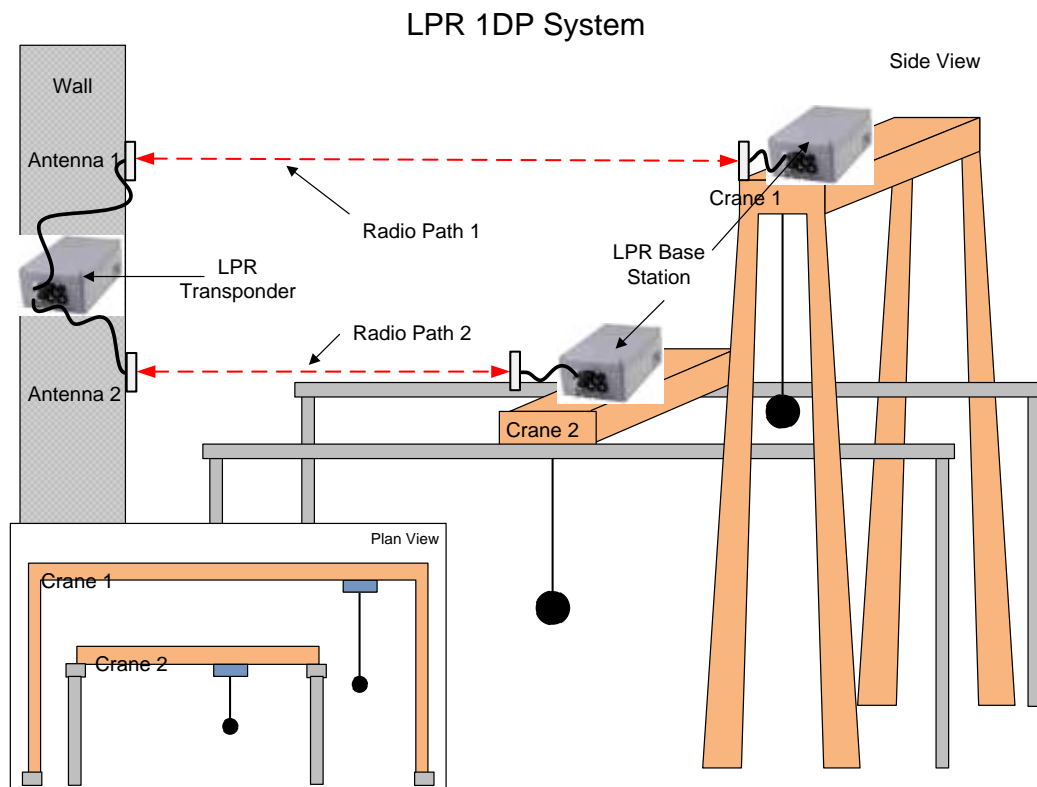
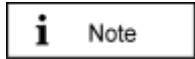

Figure 8: LPR® 1DP Y-shaped arrangement

3 Hardware



All corresponding installation, repair and servicing work must be carried out by qualified and trained technicians.



Using beside the LPR® station with design “Compact Station” a LPR® station with design “Integral Station” a separate document with hardware and installation description is provided.

3.1 LPR® Station (Design Compact Station)

The Compact type LPR® station is factory configured variously according to different requirements:

- With or without TCP/IP (ARM9 board)
- With or without switching outputs for up to 7 relays
- 2 or 4 antenna ports

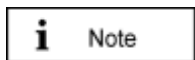

The option for additional relay outputs is not provided with 4 antenna outputs.

Technical Data and Description of Interfaces	
Power draw	Voltage range 10-36VDC RS232 port, with / without relay: 7 W / 4 W TCP/IP port, with / without relay: 8 W / 6 W
Dimensions (LxWxH)	260 x 160 x 91 mm
Type of protection	IP 65 with appropriate cable connectors
Connections	Power-Supply and Communication: Plugged connection Antenna: Screwed cable gland Ethernet: Plugged connection
Antennas	Connection of up to 4 independent antennas
Compliance	CE mark, part 15 FCC ⁽¹⁾ , RSS-210 ⁽¹⁾

⁽¹⁾ Only valid for BSB00056.

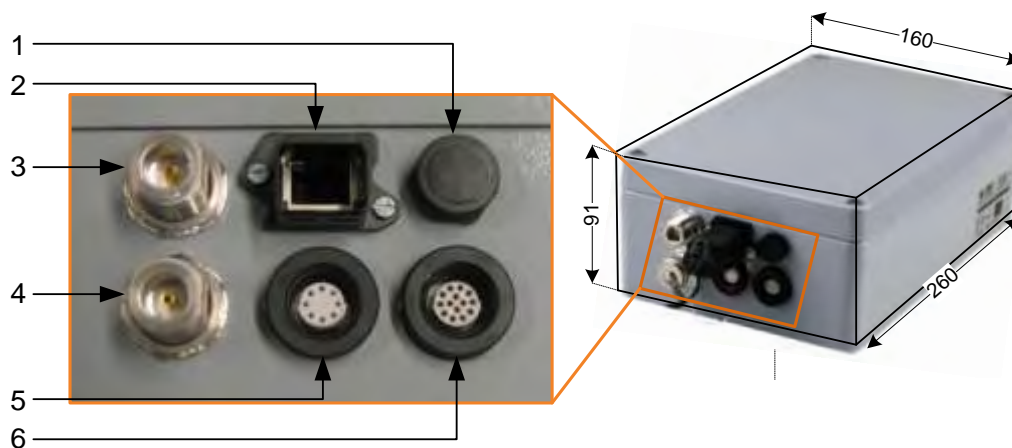
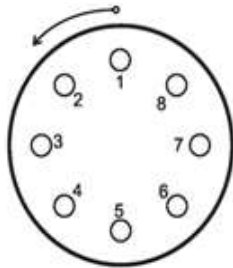

Figure 9 LPR® Station (with network interface, dry contacts and 2 antenna interfaces)

Description of Interfaces	
Nr. 1	Pressure equalization membrane. The membrane prevents forming of condensation water inside the Compact Station. The pressure equalization membrane must not be changed or covered!
Nr. 2	Network (optional). The standard industrial Ethernet port of the station is designed as a Harting type push pull connector.
Nr. 3, 4	Antenna connections. The antennas are connected to the Compact Station via a specially converted low-loss HF cable with N-plug. 3: Antenna port no. 1, 4: Antenna port no. 2.
Nr. 5	Power supply with integrated communication ports. Power is supplied via a Lumberg Type 0233 08 push pull connector. There is no power switch because of the intended area of application. A 3 Ampere (slow blow) fuse is mounted inside the Compact Station.
Nr. 6	Connection for relay outputs (optional). The relays are connected by means of a type 0233 14 Lumberg push pull connector.

3.1.1 PIN-Assignment of Lumberg Type 0233 08 (Power Supply, RS232-Interface)



Pin	Function
1	UBB (+)
2	UBB (-)
3	LPR® data port RXD
4	LPR® data port TXD
5	Network diagnostic port RXD
6	Network diagnostic port TXD
7	GND-RS232
8	GND RS232

Table 1 : Solder side view of the pin assignment of the Lumberg power connector plug (power supply with integrated service port)

i Note

For configuration of the connector with cables, you have to identify the matching pin assignment on the solder side.

The connectors have an anti twist device.

Option 1: It is possible to order cables (length: 5 m) by Symeo with integrated Lumberg connector and cut cable head (see chapter 3.2.1).

Option 2: It is possible to order a connection box for wire all cables (see chapter 0).

i Note

When plugging the push pull connectors into their sockets check that the plug doesn't slip out of the socket when pulling slightly at the cable.

3.1.2 PIN-Assignment of Lumberg Typ 0233 14 (Relays)



Pin	Name	Function
1	R1P	The function of the relay 1 to 7 can be individually programmed with the LPR® 1D Wizard.
2	R1N	
3	R2P	
4	R2N	
5	R3P	
6	R3N	
7	R4P	
8	R4N	
9	R5P	
10	R5N	
11	R6P	
12	R6N	
13	R7P	
14	R7N	

Table 2 : Solder side view of the pin assignment of the Lumberg relay connector (relay outputs)

i Note

For configuration of the connector with cables, you have to identify the matching pin assignment on the solder side.

The connectors have an anti twist device.

Option 1: It is possible to order cables (length: 5 m) by Symeo with integrated Lumberg connector and cut cable head (see chapter 3.2.2).

Option 2: It is possible to order a connection box for wire all cables (see chapter 0).

i Note

When plugging the push pull connectors into their sockets check that the plug doesn't slip out of the socket when pulling slightly at the cable.

3.2 Cables for LPR® Station

3.2.1 Assembled Cable for power supply and service port

Cables are delivered with a cable length of 5m and can be cut to the required length.



Figure 10 Cable for power supply with integrated interface

PIN-Assignment of Cable Lumberg Connector 0223 08		
Plug	Lumberg 0223 08	
Cable	8-wire AWG24 UL/CSA; cladding diameter = 6.4mm	
Color (DIN 47100)	Pin / color	Function
	1 – white	UBB (+)
	2 – brown	UBB (-)
	3 – green	LPR® Dataport RXD
	4 – yellow	LPR® Dataport TXD
	5 – grey	Network diagnostics port RXD
	6 – pink	Network diagnostics port TXD
	7 – blue	GND-RS232
	8 – red	GND-RS232 and shielding



Consider the dependency of the maximum baud rate according to the cable length:

- 15m: 19.200baud
- 5m: 57.600baud
- <2m: 115.200baud

According to the cable length the baud rate at the stations has to be adjusted.



If this cable is only used for power supply, the TXD-wires of the cable must be terminated. Otherwise signals from other systems can disturb the

system via the TXD-wire. Then measurements can fail. You have to ground the TXD-wires (PIN 4 and PIN 6) with PIN 7 and 8.

3.2.2 Assembled Cable for relays

Cables are delivered with a cable length of 5m and can be cut to the required length.



Figure 11 cable for relays

PIN-Assignment of cable Lumberg Stecker 0223 14		
Plug	Lumberg 0223 14	
Cable	16-wire (14 wires are only used!) AWG24 UL/CSA; cladding diameter = 6.4mm	
Color (DIN 47100)	Pin / color	name
	1 – white	R1P
	2 – brown	R1N
	3 – green	R2P
	4 – yellow	R2N
	5 – grey	R3P
	6 – pink	R3N
	7 – blue	R4P
	8 – red	R4N
	9 – black	R5P
	10 – violet	R5N
	11 – grey-pink	R6P
	12 – red-blue	R6N
	13 – white-green	R7P
14 – brown-green	R7N	

3.2.3 Ethernet Cable

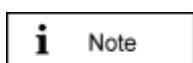

For FCC/IC compliance: Ethernet cables must be equipped with a ferrite core near the TCP/IP interface at the LPR® station. Otherwise this device may not operate correctly and will not be in compliance with part 15 of FCC rules and with RSS-210 of industry Canada.

3.3 LPR® Connection Box

The connection box is configured with 14 clamps. Therefore the connector box can be used either for power supply or for relays.

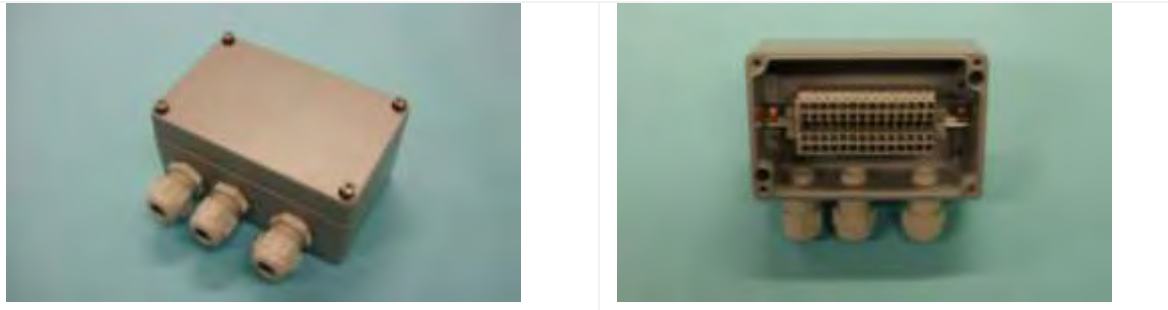

Figure 12 Connection Box

Connection Box	
Size (LxWxH)	125mm x 80mm x 57mm (without cable bushing)
Position mounting holes	4 x diameter 4.3mm; 52 x 113mm
Clamps	Wago 870-911 for cable diameter 0.08 till 2,5mm ² (till 4mm ² if flexible cables)
Cable bushing	3 x PG Connection for cladding diameter 5 – 10 mm 1 x sealing cap
Protection category	IP65 If usage of appropriate cables (diameter 5 till 8mm) and correct connection of cap and cable bushing is assured

i Note

If the cable bushing are not used the sealing cap (including the sealing ring) has to be mounted to keep the protection category IP65.

3.3.1 Example Connector Box

Connection of a 8-pin cable

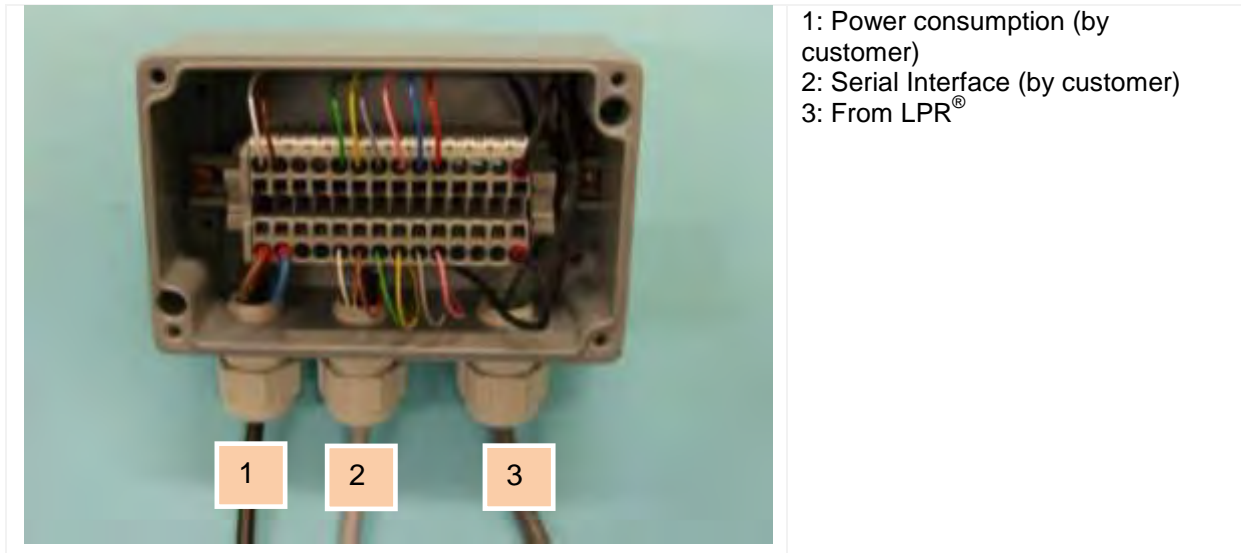



Figure 13 Example for wiring connector box with 8 pins

In this example the power supply is at pin1 and 2. The serial interface is at pin 5 to 10 and the shielding at pin 14.

 Note

The shielding has to be allocated.

For safety of clamping use appropriate wires end sleeves according to AWG24. Zur Sicherung der Klemmung ist die Verwendung geeigneter Adern Endhülsen, passend zu AWG24 bzw. gemäß den kundenseitig verwendeten Kabeln, vorzusehen.

 Warning

If this cable is only used for power supply, the TXD-wires of the cable must be terminated. Otherwise signals from other systems can disturb the system via the TXD-wire. Then measurements can fail. You have to ground the TXD-wires (PIN 4 and PIN 6) with PIN 7 and 8.

Connection of a 14 pin cable.

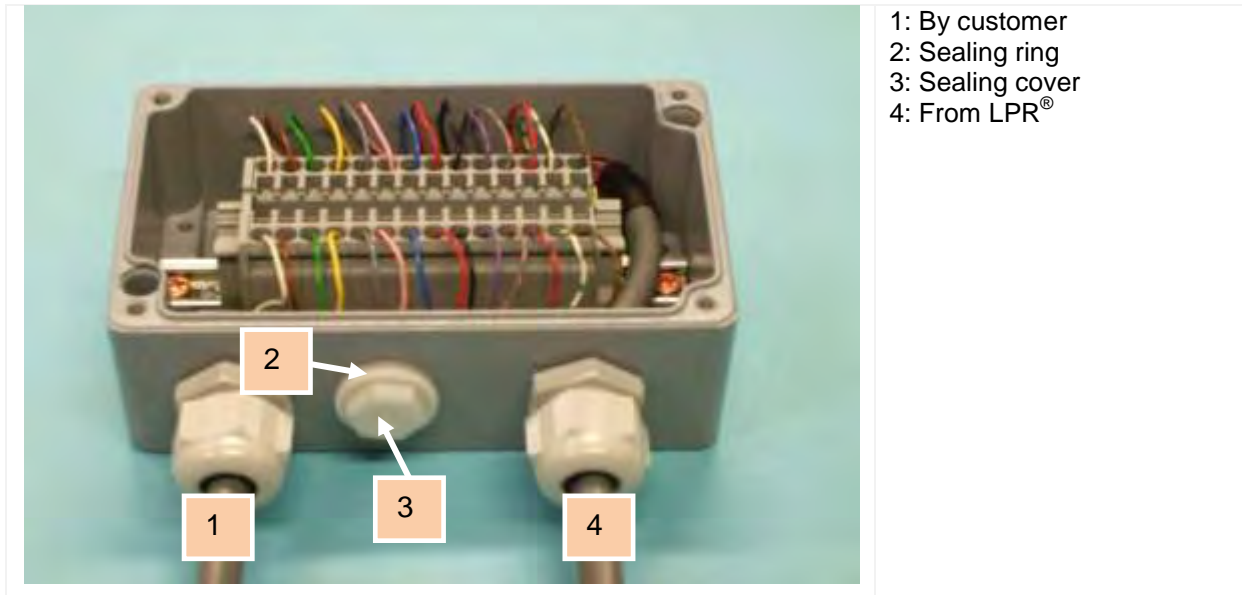

Figure 14 example for wiring of connector box with 14 pins

The dry contacts have to be connected to the clamps 1-14. The cable gland in the middle has to be protected with a sealing cap to keep protection category IP65.

3.4 LPR[®] Antenna Types

There are different antennas that can be installed depending on the required directional characteristic.

Figure 15 shows the typical LPR[®] antennas, which are applied in an LPR[®] System.

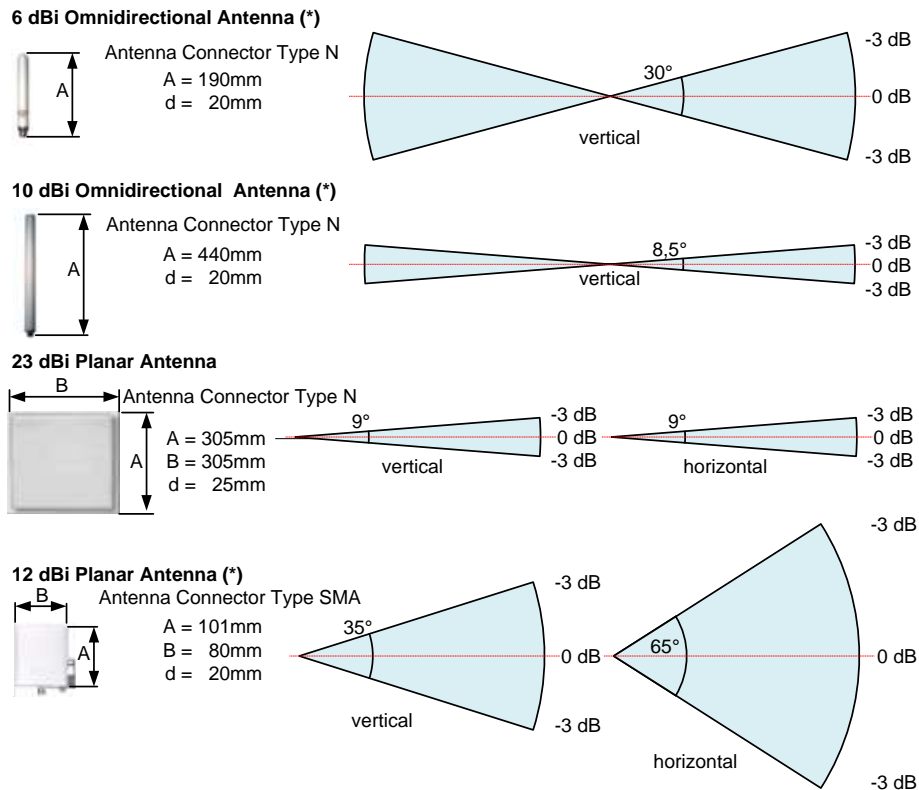

10 dBi Sector Antenna (*)

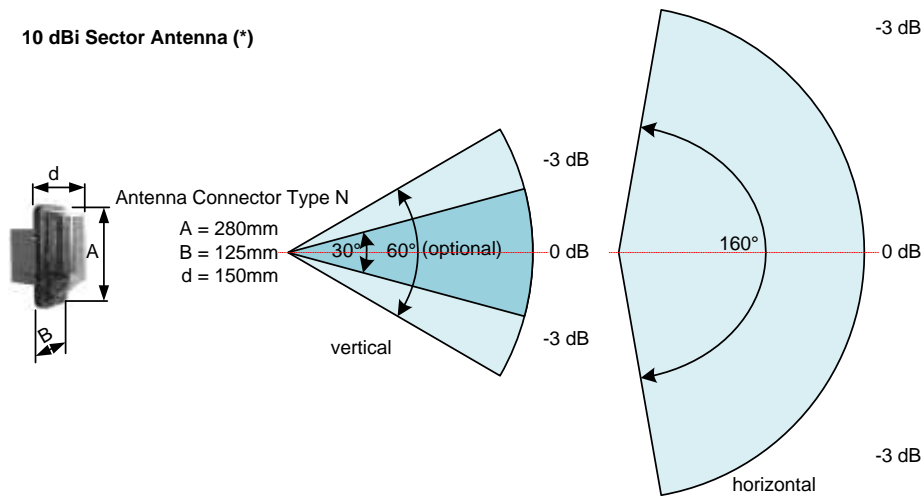

14 dBi Sector Antenna (*)

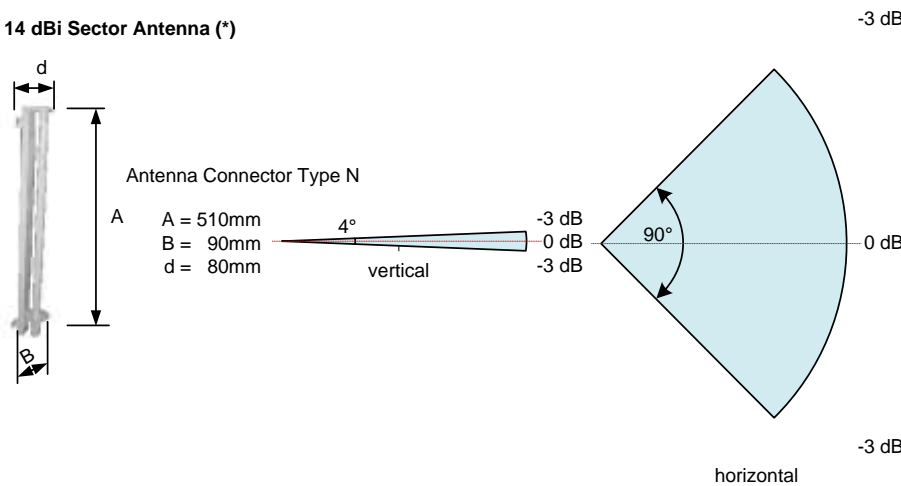

Figure 15: Example of directional characteristic of typical LPR® antennas

(*) These antennas are NOT approved to be in compliance with part 15 of FCC rules and with RSS-210 of Industry Canada. Usage of these antennas may void the FCC/IC authorization to operate this equipment.

Further information is found in the Appendix.

i Note

Installation and exchange of antenna or antenna cables must be carried out by qualified and trained technicians!

Usage of antennas or antenna cables which are not listed to be in compliance with FCC and IC rules is strictly prohibited!

3.4.1 Adapter for different LPR® Antennas

Depending on the required antenna, different adapters are available

6 dBi and 10 dBi Omnidirectional Antenna

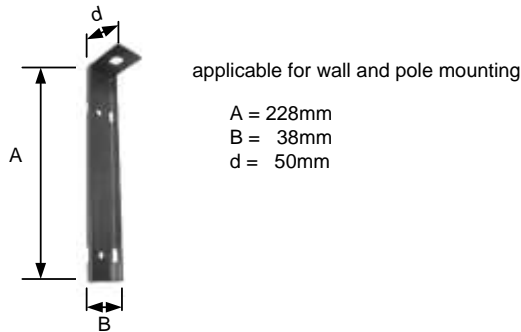

23 dBi Planar Antenna

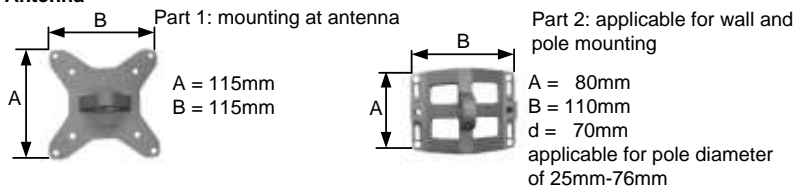

12 dBi Planar Antenna

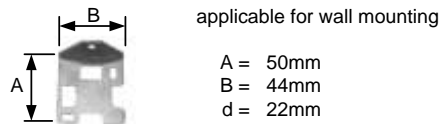

10 dBi Sector Antenna

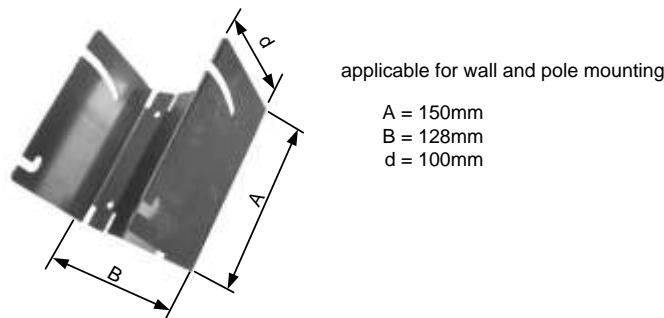

14 dBi Sektor Antenna

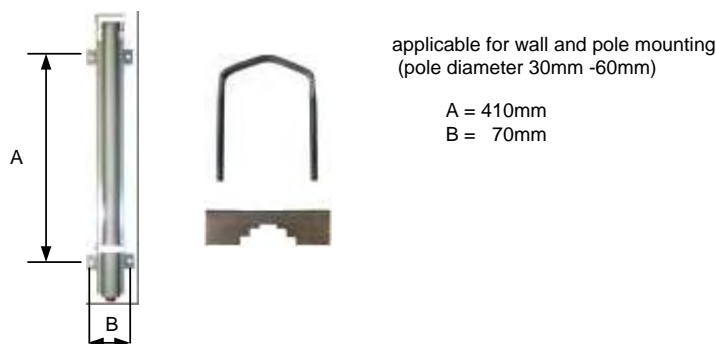
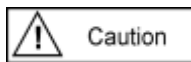

Figure 16: Available Adapters for different Antenna Types

4 Installation

4.1 Installation of LPR® Station Design Compact Station

4.1.1 Important Instructions for Installation



During Installation, the Compact Station has to be opened. Therefore it is important to avoid ingress of moisture, dust or any particles into the housing during the installation process. Make sure that there is enough room for the connectors, and particularly that the antenna cable is accessible; pay attention to the permitted bending radius (center of radius to cable core) for standard cables of 10,5cm (for multiple bending under mechanical load) and 4cm (unloaded and static bending).

The Compact Station should preferably be installed so that the connecting sockets point downwards. In this way, the connections are protected from rain and dust.

4.1.2 Installation

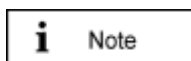

To install the Compact Station, you require 4 round head M6 x 30 screws (at least).

- ⇒ Check the position of the station on the device on which the Compact Station is to be installed (e.g. a crane bridge). Bear in mind the installation instructions listed above.
- ⇒ Drill holes in the device on which the Compact Station is to be installed. Drill-hole distances: 11 cm wide, 24 cm high (see figure 7).
- ⇒ Open the Compact Station: With a Phillips screwdriver (Size 0), loosen the top four screws of the Compact Station lid.
- ⇒ Screw the Compact Station tightly to the device. The installation holes shown in figure 2 are provided for this purpose. Check that the station is mounted securely.
- ⇒ Close the station: Place the cover of the Compact Station on top and fasten the cover with the four screws. Make sure that the cover is securely attached to the housing.
- ⇒ Commission the Compact Station (see chapter "Base Station Initialization")

4.2 Installation of LPR® Antennas

4.2.1 Connecting and Wiring up the Antenna and Cable

Connect the antennas to the antenna port at the LPR® station.

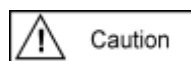

When using several antennas, ensure that they are connected to the correct ports.

	Transponder Station 1	Base Station Station 2	Base Station Station 3	Base Station Station 4	Base Station Station 5
Measured Distance 1	Antenna Port 1	Antenna Port 1	x	x	x
Measured Distance 2 (optional)	Antenna Port 2	x	Antenna Port 1	x	x
Measured Distance 3 (optional)	Antenna Port 3	x	x	Antenna Port 1	x
Measured Distance 4 (optional)	Antenna Port 4	x	x	x	Antenna Port 1

- ⇒ When installing the cable, ensure that electrostatic charging does not occur.
- ⇒ Make sure that the cable is not kinked or trapped during installation. The minimum bending radius must always be maintained. With the standard antenna cables delivered, the minimum bending radius (center of radius to cable core) for standard cables is 10,5cm (for multiple bending under mechanical load) and 4cm (unloaded and static bending). The cable must not be attached in a way that alters its cross-section. On demand, cables with different flexibility characteristics are available.
- ⇒ The antenna plug must not be removed (e.g. for installation purposes) or repaired because the specified electrical properties can only be achieved with mechanical installation assistance.
- ⇒ When installing the antenna cable, ensure that the screw connection is seated properly. The antenna cable plugs should be finger-tightened before tightening with an appropriate tool to no more than 1.3 Nm tightening torque.

4.2.2 Installing the Antenna(s)

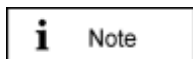

The line of sight between the antennas on each unit must not be obstructed. Therefore, when installing the antenna fixture, ensure that no components are blocking the line of sight between the antennas. If necessary, contact the SYMEO technical department.

Depending on the antenna type used, offsetting the corresponding antennas (either vertically or horizontally) may degrade the signal strength to the point that communication is lost. Accordingly, corresponding antenna pairs should be installed with as little offset with respect to each other as possible, and preferably none. If necessary, contact the SYMEO technical department.

If you change the position of one antenna, this will affect the measurement data that is output.

Installation

For installation of the Planar Antennas, it is important to keep the same orientation of polarization for corresponding antennas (see Figure 17).

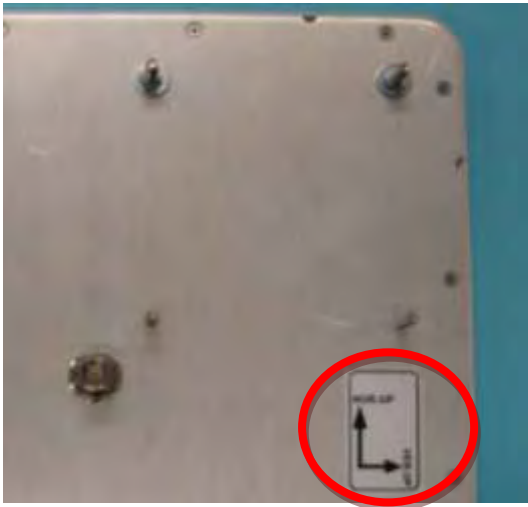
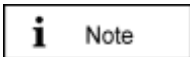

Figure 17: Backside of 23 dBi Planar Antenna

- ⇒ Install the antenna fixture according to the accompanying operating instructions.
- ⇒ Secure the antenna in the fixture.
- ⇒ Connect the antenna to the antenna cable.

4.2.3 Fresnel zone

The area for radio transmission between two antennas is called Fresnel zone. The main part of energy is concentrated in the first Fresnel zone.



This area has to be free of any obstacles otherwise the signal is interrupted or attenuated.

The first Fresnel zone can be calculated as follows:

$$b = 0.5 \cdot \sqrt{\mu \cdot d}$$

μ is the wave length and d the distance between the two antennas. For a frequency of 5.8 GHz a wave length μ of approx. 0.05 m is calculated. The maximum radius between the two antennas is indicated with b . For different distances the maximum radius is given in Figure 18.

distance d	radius b
10 m	0.36 m
50 m	0.80 m
100 m	1.14 m
250 m	1.80 m
500 m	2.54 m
1000 m	3.60 m

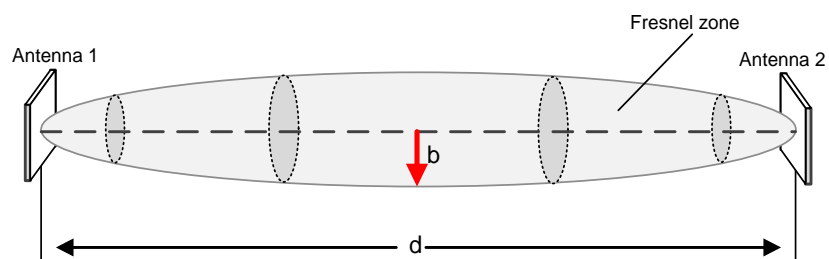

Installation

Figure 18 Calculation and figure of Fresnel zone

4.2.4 Installation of Planar Antennas



Each antenna type has its own opening angle. To communicate with the opposite antenna the relative antennas has to be located in the opening angles of the opposite antennas.

Antennas have to be mounted without any offset (no difference in height and no offset sideways). Make sure that the opening angle is symmetric to the relative direction of motion (compare picture 1 vs. picture 2 in Figure 19).

If an offset is not inevitable the antennas have to be tilted (compare picture 3 vs. picture 4 in Figure 19).



Notice: If the distance goes below a fixed distance it is possible that no measurements take place any longer.

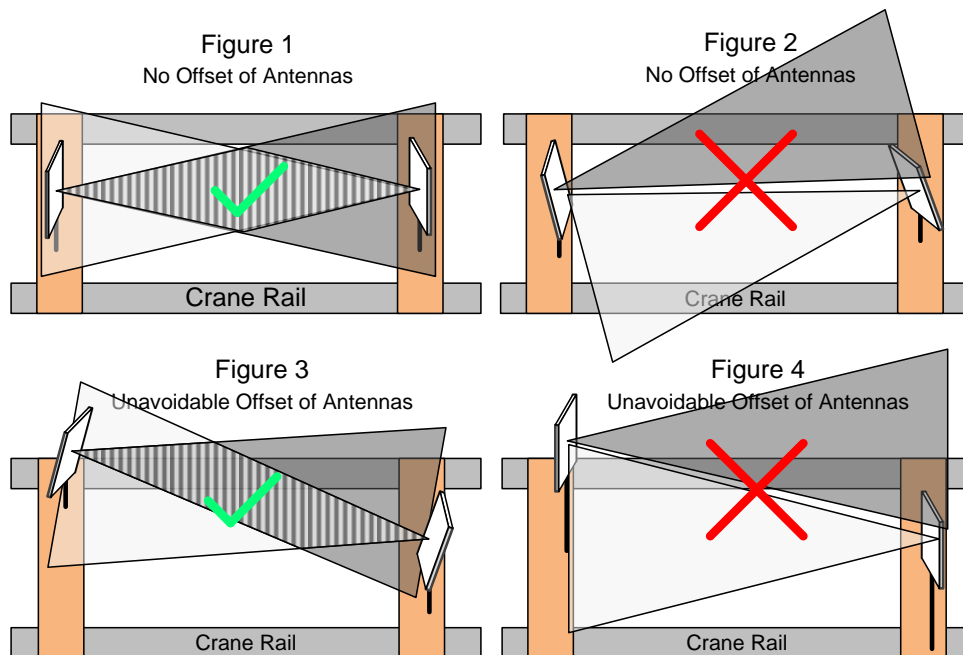

Figure 19 Antenna Position with and without Offset

5 Commissioning

5.1 Requirements

In order for a station to be successfully commissioned, the LPR® components must have been installed correctly:

- ⇒ The station has been installed.
- ⇒ The station has been connected to the power supply.
- ⇒ Antenna(s) and antenna cables for the station have been installed.

⇒ Data link has been established serially or via TCP/IP.

Once these prerequisites have been fulfilled you can connect the station either serially to a PC or as an option (TCP/IP option) to the network and commission the LPR® 1D system. How to this is explained in the following chapter.

5.1.1 General

Commissioning is carried out via the serial port or the TCP/IP port depending on the LPR® station model you have.

- Each LPR® unit is equipped with the following interfaces:
- An RS232 port for data transmission to downstream systems (PC, S7),
- A second RS232 port for parameterization and software updates
- Optionally, a TCP/IP port for data transmission and parameterization.
- The radio interface at 5.8 GHz for data transmission, communication and measuring with other LPR® units,

The two RS232 ports are incorporated in the Lumberg plug, the radio interface functions via the system antenna.

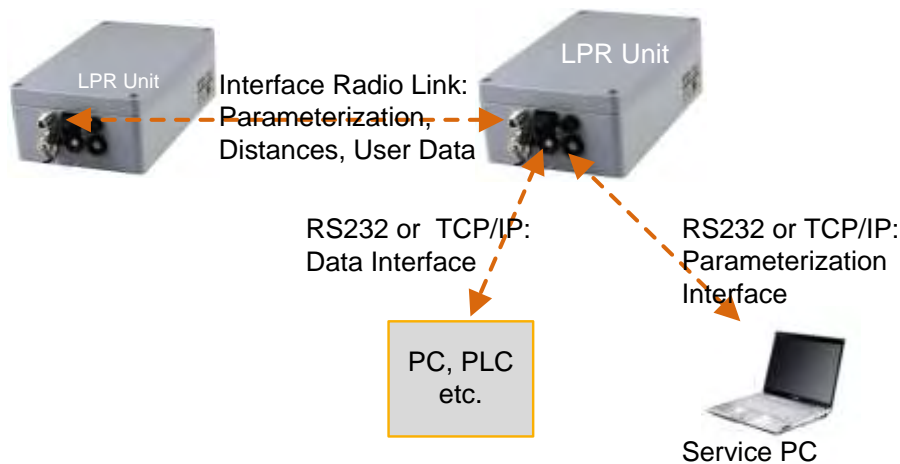

Figure 20: LPR® Unit with Interfaces for Parameterization and Protocol Data Interface (Binary data)

Possible Connection to the LPR® Station via PC

	RS232	TCP/IP	Wireless-Access (via another LPR® Station)
Parameterization (ASCII-Data)	YES (ASCII-Port)	YES (ASCII-Port)	YES (ASCII-Port)
Distance Data (Binary Data)	YES (Binary Port)	YES (Binary Port)	NO

In one LPR® system all distance data (binary data/ protocol) is available at each station. Also if you have several stations in one system (crane bridge, crane crab, wall) you get the binary data at each LPR® station in this system.

5.2 Connection to LPR® Station with TCP/IP Interface

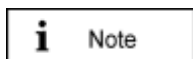

With delivery the LPR® stations have the fixed IP-Address **192.168.1.99**, if no other IP-Address is labeled outside the LPR® station.

You can change the IP-Address of the LPR® Station via the web interface of the LPR® Station.

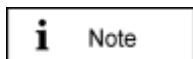

To get a connection between your PC and the LPR® station it is maybe necessary to change the network parameters of your computer. Both units must be located in the same network. That means in this example that the first three numeric pads of both IP-addresses must be the same.

Disconnect your PC from the network. Connect the LPR® station and the computer with a network cable. Open your network settings of your computer.

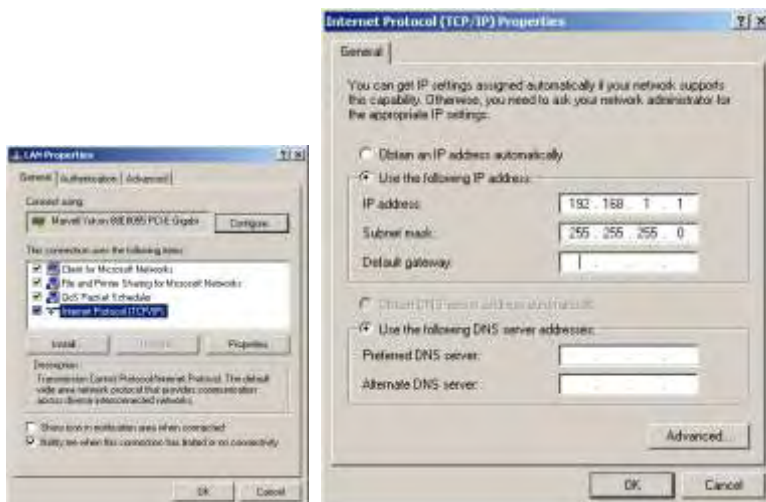

Enter the following fixed IP-Address i.e. **192.168.1.1**. The subnet mask should be set to **255.255.255.0**.

Click in both windows **OK**.

Figure 21 – Network Settings

i Note

If your firewall settings are too restrictive, you may not get access to the LPR® station. In this case deactivate temporarily under the tab „Advanced“ in Fenster Netzwerkeigenschaften die Firewall.

The LPR® Station should be available via your PC now. You can check the connection with a „ping“ to the LPR® station:

Open the Command-Window:

- ⇒ Windows Start Button
- ⇒ Choose Run
- ⇒ Enter cmd and click OK
- ⇒ Enter in the cmd.exe window: ping 192.168.1.99 or the IP-address of the LPR® station.

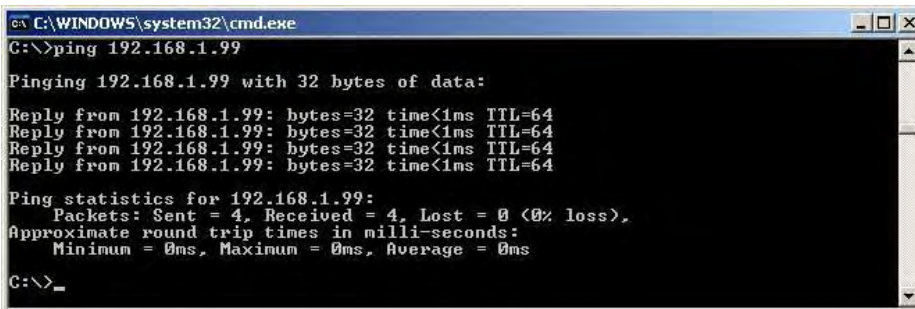

```
ex C:\WINDOWS\system32\cmd.exe
C:\>ping 192.168.1.99

Pinging 192.168.1.99 with 32 bytes of data:
Reply from 192.168.1.99: bytes=32 time<1ms TTL=64
Reply from 192.168.1.99: bytes=32 time<1ms TTL=64
Reply from 192.168.1.99: bytes=32 time<1ms TTL=64
Reply from 192.168.1.99: bytes=32 time<1ms TTL=64

Ping statistics for 192.168.1.99:
    Packets: Sent = 4, Received = 4, Lost = 0 (0% loss),
    Approximate round trip times in milli-seconds:
        Minimum = 0ms, Maximum = 0ms, Average = 0ms

C:\>_
```

Figure 22 – Ping LPR® Station

The LPR® Station should answer with a ‚Reply‘.

5.3 Connection LPR® Station with serial Interface

i Note

The interface RS232 is only available for station without TCP/IP interface. If a RS232 interface for station with TCP/IP interface is desired, please contact the Symeo Service.

The commissioning could either be done via the serial interface of the 8-pin Lumberg connector (Figure 23) or the serial interface inside the box (Figure 25).

⚠ Warning

Consider the dependency of the maximum baud rate according to the cable length:

- 15m: 19.200baud
- 5m: 57.600baud
- <2m: 115.200baud

According to the cable length the baud rate at the stations has to be adjusted.

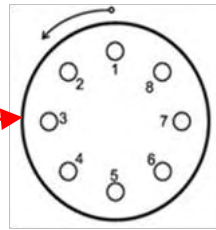

Pin	Function
1	UBB (+)
2	UBB (-)
3	LPR® data port RXD
4	LPR® data port TXD
5	Network diagnostic port RXD
6	Network diagnostic port TXD
7	GND-RS232
8	GND RS232

Figure 23 – Lumberg-Interface for Serial Interface



Pin / Color	Function
1-ws	UBB (+)
2-bn	UBB (-)
3-gn	LPR® Dataport TXD
4-ge	LPR® Dataport RXD
5-gr	Network diagnostic port RXD
6-rs	Network diagnostic port TXD
7-bl	GND-RS232
8-rt	GND-RS232

Figure 24 – Lumberg-Connector Cable for Serial Interface

To commission the system via the internal serial interface you must use the internal configuration port. Therefore a standard RS232 cable of a max cable length of 2 m is required.

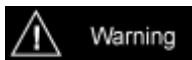

Using the internal serial interfaces it is important to avoid ingress of moisture, dust or any particles into the housing during the process



Figure 25 Internal view of LPR® Station

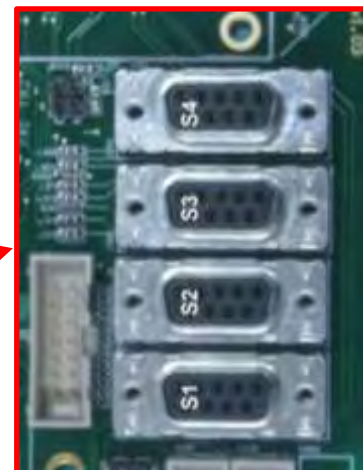

Figure 26 – Internal Data Interfaces

Internal Data Interfaces

S4	Configuration Port/ ASCII Port
S3	A9 serial
S2	Binary Port (Protocol XP)
S1	ARM9 serial

Connect one side of RS232 cable of a cable length of 2 m with your PC and the other side with the LPR® station (ASCII Port S4). Check the right port of your COM-Port in the device manager of your computer.

5.4 Commissioning Tool – LPR® 1D Wizard

5.4.1 Installation

Install the provided LPR® 1D Wizard on your computer.



Figure 27 – Installation File LPR® 1D Wizards



Commissioning

Figure 28 – Setup 1



Figure 29 – Setup 2

Figure 30 – Setup 3

After finishing the installation process, you can open the LPR®-1D Wizard via the Windows menu.

5.4.2 Utilization of LPR® 1D Wizard

The commissioning of the LPR® 1D system with the LPR®-1D Wizard proceeds the following:

- ⇒ Selection of the desired application
- ⇒ Settings of parameters for selected application
- ⇒ General setting of LPR® 1D System (ID, Antenna parameters, etc.)
- ⇒ Connection to LPR® Station(s)
- ⇒ Download of currently applied application as Backup-file
- ⇒ Upload of new selected application to the LPR® Station(s)
- ⇒ Antenna Calibration
- ⇒ Check distance data

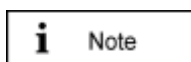

FCC/IC authorization: If software parameters will violate the agency certifications in United States (FCC) and Canada (Industry Canada) the LPR® system may not work correct due to limiting the output power of the station by firmware.

⇒ Start the LPR® 1D Wizard. The following window appears:

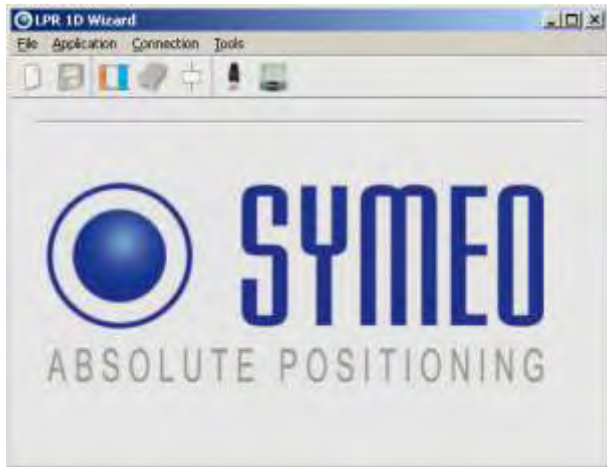

Figure 31 – Start LPR® 1D Wizard

The construction of the menu looks like the following:

Menu ,File': open and save configuration files.

Menu ,Application': Selection of application and settings for LPR®-Systems (IDs, allocation of relays,...)

Menu ,Connection': Connection to LPR® system.

i Note

You find many Info buttons. These info buttons explain in more detail the functionality of an action.

Selection of application

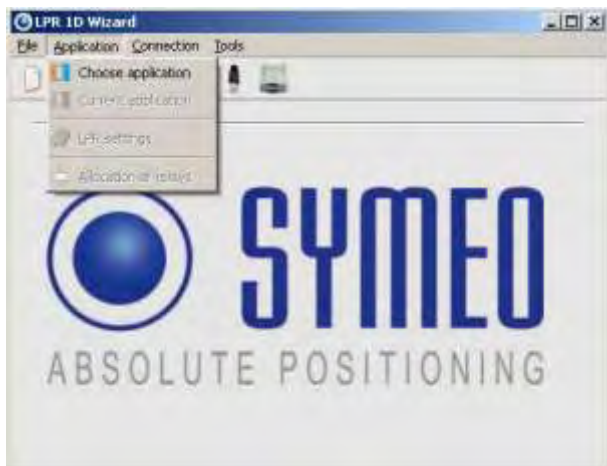

Figure 32 – Selection of application

Select in the menu ,Application' the submenu ,Choose application' to open possible applications..

i Note

As long as no application is chosen no further submenu could be selected.

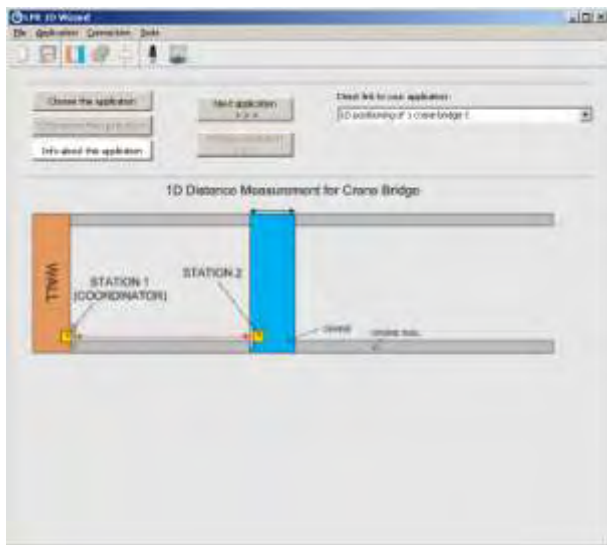

Figure 33 – Overview of application

The first possible application is shown.

You can see other application with the buttons 'Next application' or previous application'.

Or you can open a known application via the selection list 'Direct link to your application'.

i Note

Not till then you have pressed the button 'Choose this application' the application is selected.

The button 'Info about this application' contains a short description of the application.

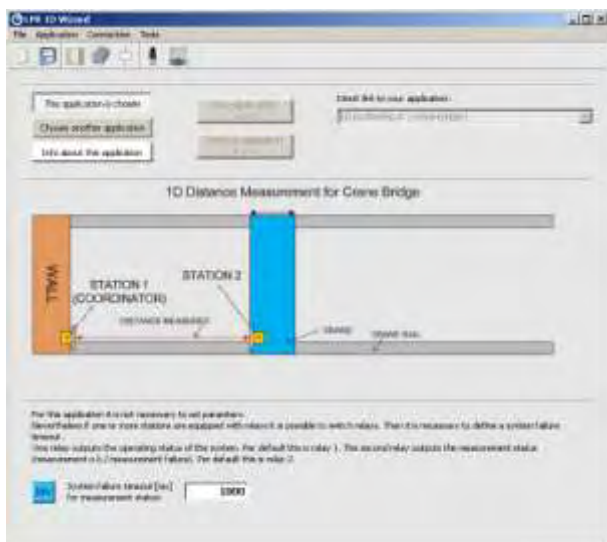

Figure 34 – Settings of parameters of selected application

If the application is selected (The button 'Choose this application' is pressed) additional fields appear. Depending on the application you have fill out these input fields.

i Note

The meaning of each input field is available by pressing the button 'Info'.

Settings of LPR® System Parameters

After selecting the application some common settings of the LPR® system must be done. Select the menu 'Application' and the submenu 'LPR® settings'.

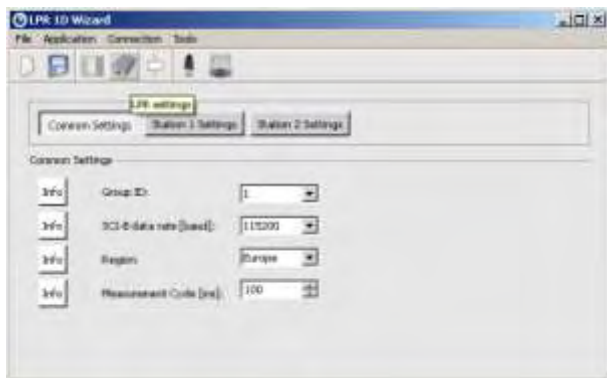

Figure 35 – General settings 1 of LPR® system

The 'Common Settings' include settings of LPR® Systems. You have to make these settings.

Group ID: Clear ID of the LPR® system. All station in one LPR® system have the same group ID.

SCIB-data rate: Transmission rate of the LPR® system. Per default this value is set to 115200 baud.



Caution

If you change the baud rate, you should also adjust the measurement rate of the system.



Figure 36 – General settings 2 of LPR® system

Region: Choose the region where the system is installed. This is important to calculate the allowed transmission power.

Measurement rate: Adjust the desired measurement rate of the system. Depending on the application you can choose measurement rates of 35 ms to 250 ms.

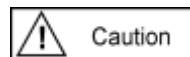

Caution

If more than one LPR® system is used you have to use for each system a different group ID.

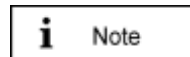

Note

You cannot select in the Wizard the frequency channel because this is linked to the group ID of the system.



Figure 37 – General settings 3 of LPR® –B system

'Station 1 Settings' and 'Station 2 Settings' (optional 'Station 3 Settings') include the settings of the antenna parameters.

This is important to calculate the allowed transmission power.

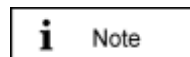

Note

It is important to note the right allocation the antenna cables to the right antenna ports. Station 2 and 3 always use only antenna port 1. At station the antenna which measures with station 2 is connected to port 1, the antenna which measures with station 3 is connected to port 3.



Figure 38 – Antenna ports of LPR® Station

Optional: Usage of Relays

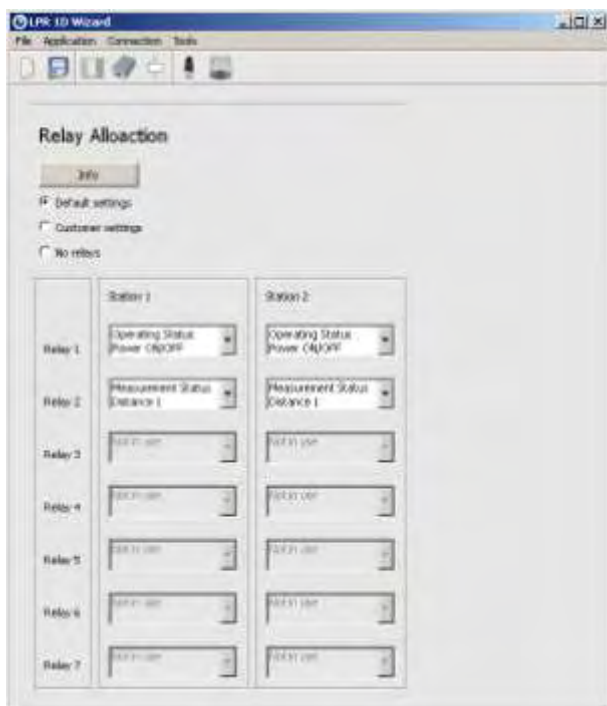
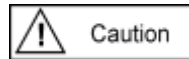

Figure 39 – Allocation of relays

If relays are used at one or more LPR® stations you can allocate functionalities to each relay depending on the selected application.



Caution

If the relay selection is skipped no relays are switched at the LPR® station

You can choose between default settings, customer settings and no relay.

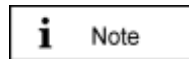

Note

The possible functionalities of the relays depends on the application you have selected.

Connection to LPR® Station

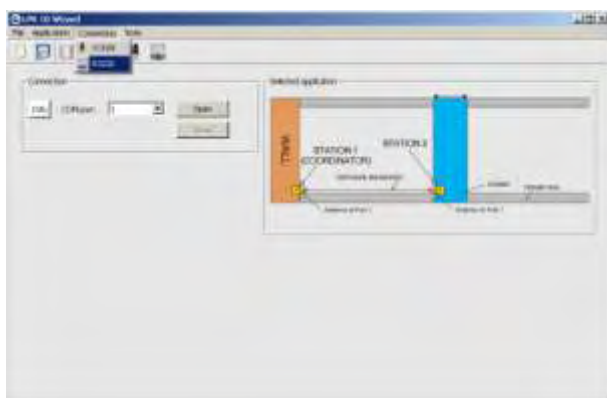
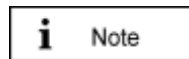

Figure 40 – Connection to LPR® station

Having established a connection to the LPR® station as described in chapter 5.2 and 5.3 the connection can be opened.



Note

If you are connected to the LPR® station with TCP/IP interface, you choose this connection type. For serial connection you choose RS232.

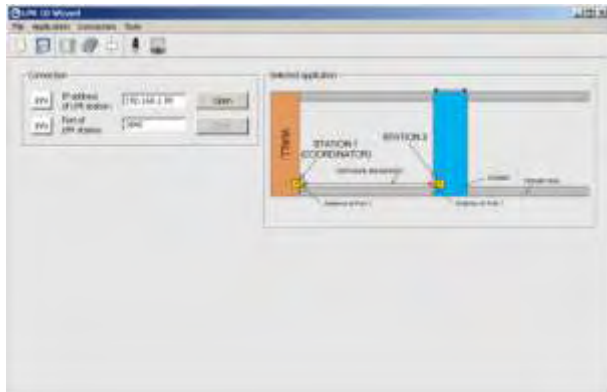

Figure 41 – TCP/IP Connection to LPR® station

TCP/IP Connection:

To open the TCP/IP connection you have to enter the IP-address and the port number. The configuration port is 3045 per default. It can be changed in the web interface of the LPR® station (see chapter xxx).

RS232 Connection:

To open the serial connection select the right COM port of your computer.

i Note

You can control the COM port number in the device manager of your computer.

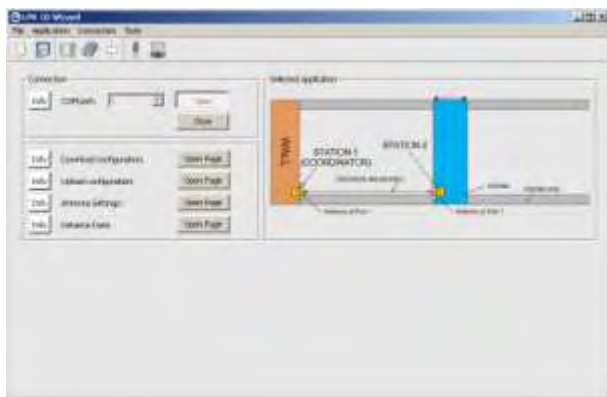
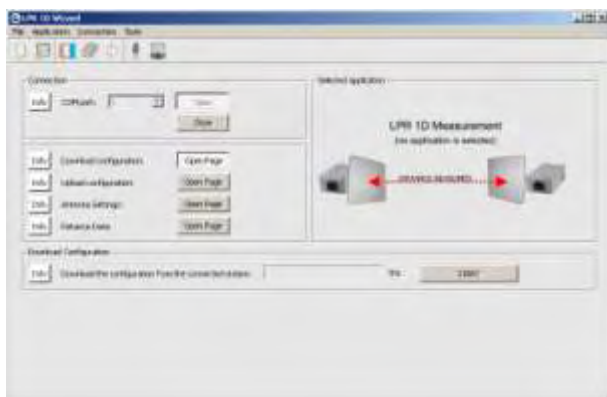

Figure 42 – Open connection

The following submenus appear:

- Download Configuration
 - ⇒ Download of old configuration
- Upload Configuration
 - ⇒ Upload of new selected configuration
- Antenna Settings
 - ⇒ Calibration of antennas
- Distance Data
 - ⇒ Measured Distance(s)

Download Configuration



Before uploading a new application make a download of the current application to have these files later as a backup.

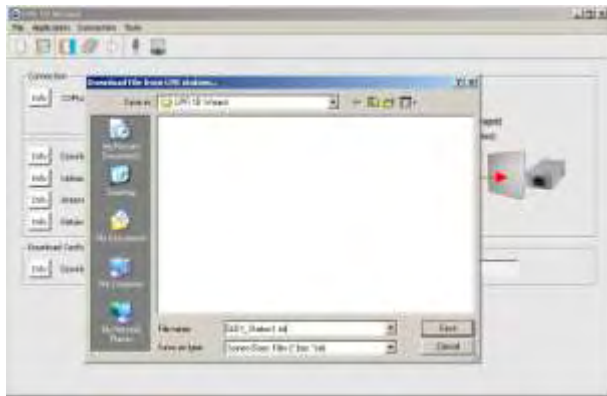

Press the button ,Start'. Enter the desired file name. Symeo recommends entering the station number, the group number or the serial number to distinguish later the configuration files of all stations.

i Note

The serial number is labeled outside the LPR® station.

Upload Configuration

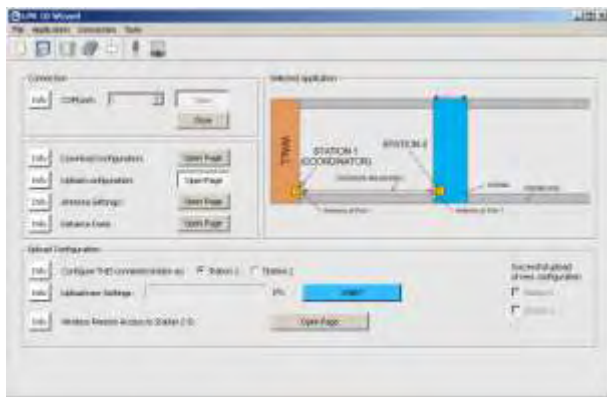

Pressing the button ,Upload' the application can be uploaded to each LPR® station.

! Caution

If settings were changed or a new application is chosen, all stations must be uploaded.



Select the station for the upload. The picture assist you which station you should select.

Press the ,Start'-button.

A note appears if the uploaded was successful and the check box is also marked.

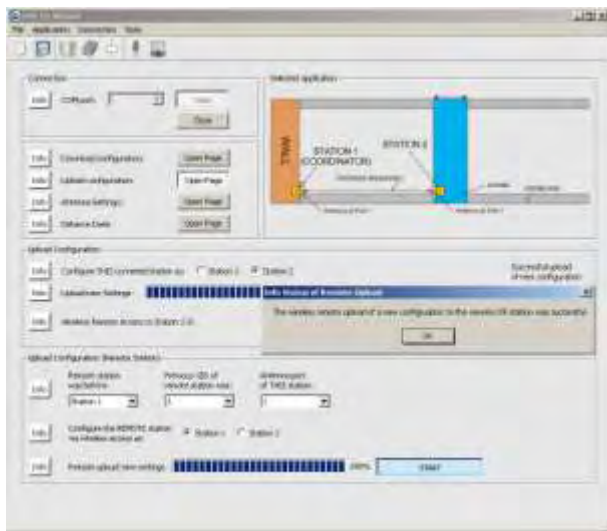

At each LPR® station an upload must be done.

You can either connect the LPR® station direct to your computer via TCP/IP or serial interface. Or you have the possibility to get wireless access via station 1 (coordinator) via the frequency channel to the other stations

But to get wireless to other stations you have to know some parameters of the opposite station. These are the previous group ID, the previous station number and the antenna port at this station.

Choose first all parameters and then select the station number which the station should have after the upload. Press the Start-button.

A note appears if the uploaded was successful and the check box is also marked.

i Note

If an antenna cable different to 4 meters is used, it might be possible you get not access the first time. Decrease in this case the distance between both antennas (i.e. by a smaller crane distance) or connect the opposite LPR® station directly to you PC.

i Note

If a new application is selected or settings are changed, you have to make an upload for each LPR® station. All checkboxes have to be marked.

Antenna Calibration

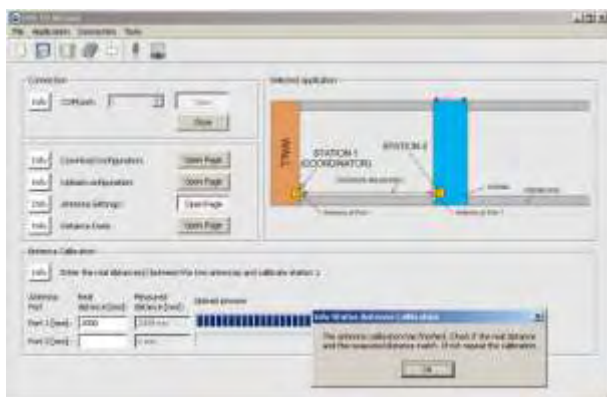

After uploading all configuration files to each LPR® station, you have to calibrate the antennas.

Click the button 'Antenna Settings'.

i Note

In the field 'Measured Distance' should be displayed the measured distance, which is different to the real distance.

Enter the real distance value between the two antennas in the field 'Real distance'. Press the button 'Calibrate'.

Port 1 is the distance between station 1 and station 2. If you have a second measurement then you enter under port 2 the real distance between station 1 and station 3. The picture assists you.

Warning

The crane is not allowed to move during the calibration process.

If the measured distance and the real distance are not the same after the calibration you might

Commissioning

repeat the calibration.

i Note

During the calibration process the antennas should have a real distance to each other of 5 to 20 m.

Display of Distance Data

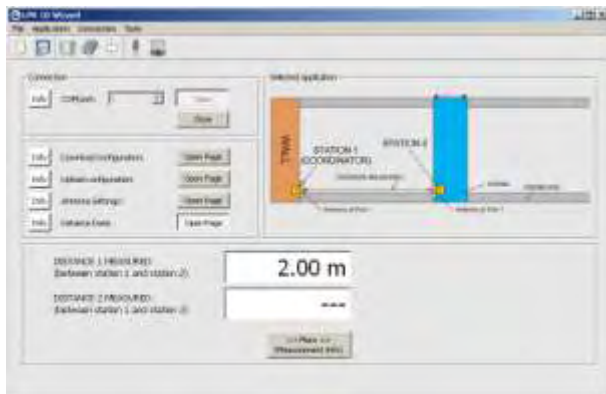

Click the button 'Distance Data' and distance value(s) is/are shown.

6 Web Server

Having a LPR® station with TCP/IP interface the network settings for this station are described in this chapter.

Therefore it is necessary to open a TCP/IP connection between your computer and the LPR® station.

6.1 Open Web Server

Open your web browser. In the address bar of the web browser enter the IP-address of the LPR® station: http://192.168.1.99. Press Enter.

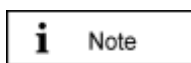

The IP-address of the LPR® station is 192.168.1.99 per delivery status except another IP-address is labeled outside the box.

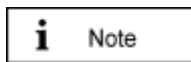

You can establish a connection with your LPR® stations Web server either via HTTP or HTTPS if the station has been configured for this (see section "Settings", "HTTP" and "HTTPS" fields in the "Remote Access" area).

In HTTP connections, the data is transmitted unencrypted. In HTTPS connections, it is encrypted for transmission (AES-256, 256-bit encryption).



A connection is established with your LPR® station.

In the case of an HTTPS connection, you may see two dialog boxes. Confirm them both with OK.

Then the Welcome page for the LPR® station's Web server will appear.

⇒ Click the function you want in the navigation bar. The individual functions are described in the following sections.

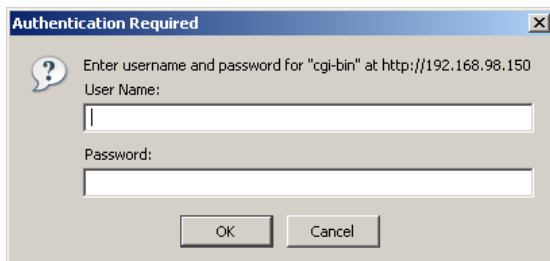

You will be prompted to enter your information for authentication.

⇒ Enter user name "symeo" and the password, and click "OK". The password has been set to "54all2u" by the manufacturer.

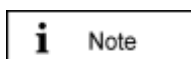

In order to protect your system from being reconfigured by unauthorized persons, you should change this to a company password that is only provided for authorized personnel.

6.2 Settings

With this function you can define the network settings on your LPR® station and the network access settings and reboot the system.

- ⇒ Click "Settings" in the navigation bar.
- ⇒ If you have not yet provided authentication information you will be prompted to do so now (see chapter 6.1).

The Settings page for the LPR® station's Web server is displayed.



The following menu is displayed:

LAN:

Overview about LAN settings of LPR® station (static or dynamic IP address) (see chapter 6.2.1)

Network:

Network settings (see chapter 6.2.2)

Serial-to-Ethernet:

Settings of parameterization port (see chapter 6.2.3)

Remote Access:

(See chapter 6.2.4)

Miscellaneous:

Setting of time zone (see chapter 0)

Special Functions:

(see chapter 6.2.6)

i Note

To accept the changings of the LPR® station press button „Upload changes“. Afterwards press button “Reboot System“ to reboot the LPR® station with the new settings.

6.2.1 „LAN“ area

MAC-Address	Unique hardware address of the LPR® station on the LAN (Ethernet ID) (not editable)
Current Mode	<p><u>Shows the current mode:</u> "Static IP-Address" or "DHCP Active". Per default the IP-address is set to the static IP-address 192.168.1.99.</p> <p>In "DHCP Active" mode, the LPR® station receives a dynamic or reserved IP address from the DHCP server. You can also ask your administrator or the SYMEO technical department about this.</p> <div style="border: 1px solid black; padding: 5px; display: inline-block; margin-bottom: 10px;">  Note </div> <p>If the LPR® station is set to „DHCP“ but does not get after the reboot within 60 sec an IP-address from the DHCP server the last applied fixed IP-address is used.</p>
Change Mode	A button is labeled "DHCP" or "Static" depending on the "Current mode" field. Click this button to switch from "DHCP Active" mode to "Static IP-Address" mode or vice versa.
IP-Address	<p>IP address of the LPR® station (default: 192.168.98.150)</p> <p>In "DHCP Active" mode, this address is assigned by the server and cannot be edited.</p> <p>In "Static IP-Address" mode you can assign a fixed (static) address here.</p>
Netmask	<p>Net mask of the LPR® station (default: 255.255.255.0)</p> <p>In "DHCP Active" mode, the net mask is assigned by the server and cannot be edited.</p>
Gateway	<p>IP address of the standard gateway (default: 192.168.98.254)</p> <p>Other LAN segments can be reached with the standard gateway.</p> <p>In "DHCP Active" mode this address is assigned by the server and cannot be edited.</p>

6.2.2 „Network“ Area

Hostname	<p><u>Hostname of the system</u> (default: "lprb-basestation").</p> <p>In "DHCP Active" mode, this hostname is also communicated to the DHCP/DNS server.</p> <p>A name that will be reserved on the DNS server can be entered here. You can also ask your administrator or the SYMEO technical department about this.</p>
DNS	<p>IP address of the DNS server:</p> <p>The DNS server is able to translate hostnames into IP addresses.</p> <p>In "DHCP Active" mode this address is assigned by the server and cannot</p>

	be edited.
Syslog	<p><u>IP address of the Syslog server</u> (default: 0.0.0.0, i.e. this service has been disabled).</p> <p>The Syslog server is a server on the network to which it is planned to have system messages (system log) transmitted. Transmission is packet-based (UDP) and unencrypted.</p>
NTP	<p><u>IP address of the NTP server</u> (default: 0.0.0.0, i.e. this service has been disabled).</p> <p>The NTP server is a server on the network from which the system can request the current time.</p>

6.2.3 „Serial-to-Ethernet“ Area

ttyAM1	Port number of the TCP/IP port via which the data from serial port (ttyAM1) is sent and received. ttyAM1 is the port for the parameterization interface (Service Port). (Default: 3045)
ttyAM2	Port number of the TCP/IP port via which the data from serial port (ttyAM2) is sent and received. ttyAM2 is the port for the data interface (Binary Port). (default: 3046)

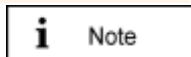

Per default these two ports are not enabled. Choose the Connection Type between the LPR® station and your PC or PLC for each port. Depending on the connection you select different masks are editable.

ttyAM1 / Parameterization Port

Network Settings Area:

IP (Server)	If applying Connection Type „TCP – Connecting to Data Port using Reserve Port“ you enter here the IP-address of the server, to which the connection should be established.
Data Port	Port-Number of TCP/IP Port. Data of serial interface (ttyAM1) is sent and received. ttyAM1 is the parameterization port. Default value is 3045.
Reverse Port	If applying Connection Type „TCP – Connecting to Data Port using Reverse Port“ you enter here the port, which the server should use for the reverse channel.

Serial Settings Area

Speed	Baud rate of serial interface (ttyAM1). The baud rate of the parameterization port is set to 115200 baud per default.
Options	Settings of serial interface ttyAM1 for the data protocol. These settings are not necessary to change and are set per default to <i>raw –echo –ixon</i> (Raw data, no echo, no control character).

Connection Type Area

Disabled	The port is disabled and not reachable via TCP/IP.
TCP – Listening on Data Port	The LPR® station is waiting for incoming connection on the “ <i>Data Port</i> ”. If the connection is opened successful you can open the parameterization port.
TCP – Connection to Data Port using Reserve Port	The LPR® station establishes the connection to the entered server address. Setting “ <i>Random</i> ” means both communication partners arrange the reverse channel autonomously. If the connection is opened successful you get access to the parameterization port.

ttyAM2 / Binary Port

Network Settings Area:

IP (Server)	For all active Connection Types the IP-address of the server is required to which the connection should be established.
Data Port	Port-Number of TCP/IP Port. Data of serial interface (ttyAM2) is sent and received. ttyAM2 is the binary port. Default value is 3046.
Reverse Port	For all active Connection Types a reverse channel for data transmission is required.

Serial Settings Area:

Packet Filter	If selected type “ <i>Fixed Frame</i> ” it is possible to filter packed data. Default value is „ <i>none</i> ”. Example: “2,3” filters the data type 0x02 (Send request) and data type 0x03 (relay switching command).
Receive Size	If selected type “ <i>Fixed Frame</i> ” it is possible to set the frame size of the received data packed. Example: For 1D-application a frame size of 15 Byte is sufficient. A smaller telegram must me filled with 0x00.
Send Size	If selected type “ <i>Fixed Frame</i> ” it is possible to set the frame size of the sent data packet. Example: For 1D-applicaion a frame size of 21 Byte is sufficient. A smaller telegram is filled with 0x00 by the LPR® station.

Connection Type Area:

Disabled	The port is „Disabled“ and not be reachable via TCP/IP.
TCP – Variable Frame – Listening on Data Port	The LPR® station is waiting for incoming connection on the “ <i>Data Port</i> ”. If the connection is opened successful you can open the binary port. „ <i>Variable Frame</i> “ means activated „ <i>Byte Stuffing</i> “ (no fixed protocol length).
TCP – Variable Frame – Connecting to Data Port	The LPR® station establishes the connection to the entered server IP-address. Setting “ <i>Random</i> ” means both communication partners arrange the reverse channel autonomously. If the connection is opened successful you get access to the binary port. „ <i>Variable Frame</i> “ means

	activated „Byte Stuffing“ (no fixed protocol length).
TCP – Fixed Frame – Listening on Data Port	The LPR [®] station is waiting for incoming connection on the “Data Port”. If the connection is opened successful you can open the binary port. „Fixed Frame“ means deactivated „Byte Stuffing“ (fixed protocol length).
TCP – Fixed Frame – Connecting to Data Port	The LPR [®] station establishes the connection to the entered server IP-address. Setting “Random” means both communication partners arrange the reverse channel autonomously. If the connection is opened successful you get access to the binary port. „Fixed Frame“ means deactivated „Byte Stuffing“ (fixed protocol length).
UDP – Fixed Frame – Sending to Data Port	The LPR [®] station sends and receives data (UDP) to and from the entered server IP-address. The reverse channel uses also the data port. „Fixed Frame“ means deactivated „Byte Stuffing“ (fixed protocol length).

6.2.4 „Remote Access“ Area

Telnet	Click this checkbox to allow or prevent console accesses to port 23 via Telnet (checked: accesses are allowed). The port number is not editable. See also section "Extended system access".
SSH/SCP/SFTP	Click this checkbox to allow or prevent console accesses to port 22 via SSH (Secure SHell and data transmission via SCP (Secure CoPy) or SFTP (Secure File Transfer Protocol) (checked: accesses are allowed). The port number is not editable. See also section "Extended system access".
HTTP	Click this checkbox to permit or forbid accesses to the LPR [®] station's Web server via HTTP (unencrypted transmission) (checked: accesses are allowed). You must also enter the corresponding port number as appropriate. The port number is set to 80 (http protocol standard) by the manufacturer.
HTTPS	Click this checkbox to permit or forbid accesses to the LPR [®] station's Web server via HTTPS (encrypted transmission) (checked: accesses are allowed). You must also enter the corresponding port number as appropriate. The port number is set to 443 (http protocol standard) by the manufacturer.
User	User ID for access to the TCP/IP port. It has been set to "symeo" by the manufacturer and cannot be changed.
Password	Enter the new password here if you want to change the password. The password has been set to "54all2u" by the manufacturer.
Repeat	Enter the new password again here if you want to change the password.

Password

Extended system access („*Remote Access*“) enables console access via Telnet, SSH (Secure SHell), SCP (Secure CoPy) and via the serial port. This enables extended system information to be retrieved and troubleshooting to be carried out. We recommend that you disable all functions that are not required, see section "Settings".

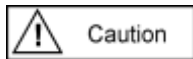

In extended system access, the user "SYMEO" has 'ROOT' privileges, i.e., full access to the system. Depending on the settings made, the system can also be damaged and such damage may or may not be repairable. If you have any questions, please contact the SYMEO technical department.

The enormous range of functions that are available to console access means that only some can be documented here. To find out more, please contact your IT administrator or Symeo Support.

6.2.5 „Miscellaneous“ Area

Timezone

If a NTP-server is available and the IP-address of the NTP-server is entered you can choose the time zone of the LPR® station. It is also possible to enter the time zone manually.

6.2.6 „Special Functions“ Area

Restore default

Click this button to restore the settings made by the manufacturer.
 ⇒ Click the "Execute" button (Restore factory default settings) in the "Special functions" area to cancel all changed settings and restore the factory settings.

The settings made by manufacturer are activated first after a reboot of the LPR® station. This means that changes of the settings (i.e. IP-address) are possible.



The settings affected will be deleted and populated directly with the factory settings.

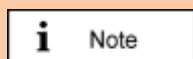

When the factory settings have been restored, it may be necessary to proceed as if commissioning the system again.

Reboot system

To accept the settings the LPR® station must be rebooted. Click this button to reboot the system.

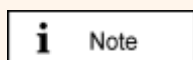

Before you reboot the system the settings must be loaded to the LPR® station by pressing button "Upload changes".

Download settings

Press the button „Download Settings“ to download a copy of the configuration as a backup.

6.2.7 Accept settings / System Reboot

As described in chapter 6.2 it is necessary to transmit the changes to the LPR® station and afterwards reboot the station.

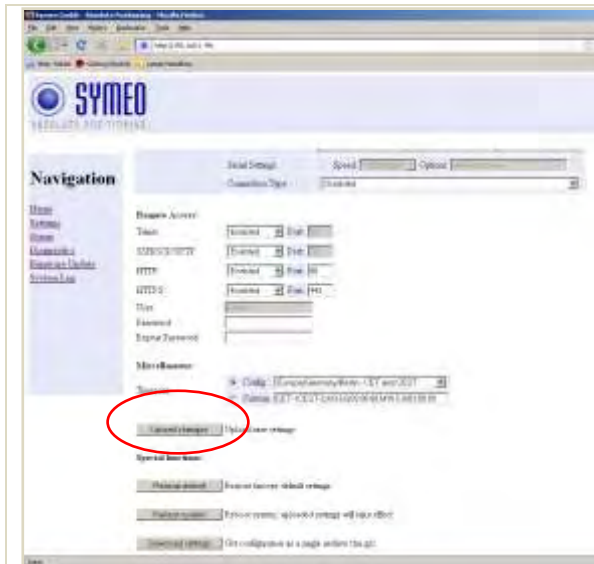

⇒ Press button „Upload changes“ to load the changes.

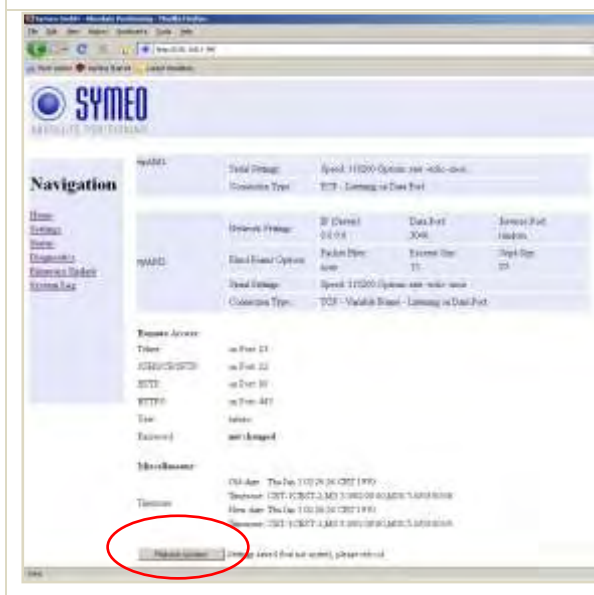

⇒ Scroll down to the end of the page and press „Reboot System“ to reboot the LPR® station.

6.3 System Status

With this function, you can display the current system status.



⇒ Click "Status" in the navigation bar.

If you have not yet provided authentication information, you will be prompted to do so now (see section "Starting and using the Web server").

The Status page for the LPR® station's Web server is displayed.

The fields have the following meanings:

Uptime	01:27:47 – Current system time up 20 min – Time since the last system start load average: 0.00, 0.00, 0.00 – Average system load for the last 1, 5 and 15 minutes. The load indicates how many processes are waiting to receive computing time
Memory (RAM)	MemTotal: Total usable working memory (physical RAM less a number of reserved bits and the kernel code) MemFree: Free working memory
Filesystem	Details about the active file systems and associated statistics.
OS Version	Operating system, kernel, compiler and compiling date
SVN Version	Current version of software
Description	Description of the system
System Date	Current system time
Watchdog	Status of the hardware watchdog, including counter of start operations since the last switch-on (connection of the power supply). A value between 2 and 127 means that the watchdog has triggered that number of system restarts. The counter is reset at 'power-on-reset' (connection of the power supply) and 'user-rest' (jumper on motherboard). In a reboot (e.g. from the Web page), the current counter status is not reset.
CPU Info	Serial Number: Globally unique identification number of the processor used (applied to each chip individually with a laser during production). Silicon Revision: Version of the processor used

0x0 Rev. A
0x1 Rev. B
0x2 Rev. C
0x3 Rev. D0
0x4 Rev. D1
0x5 Rev. E0
0x6 Rev. E1
0x7 Rev. E2

6.4 Diagnostics



Connections: State of the active and inactive connection to the LPR® station

Partitions: Size and name of available partition of non-volatile memory.

i Note

The size of receive buffer (Recv-Q) and send buffer (Send-Q) should be zero if possible. A long lasting value greater zero means problems when receiving or sending data. This happens if the data cannot be readout fast enough.

Example 1 – waiting for incoming connection:

Proto	Recv-Q	Send-Q	Local-Address	Foreign Address	State
tcp	0	0	0.0.0.0:3045	0.0.0.0:*	LISTEN

If Connection Type „TCP - Listening on Data Port“ (ttyAM1) is enabled this table shows further connection information.

Proto: Protocol (TCP, UDP)

Recv-Q: Number of buffered Bytes, which are received from the LPR® station

Send-Q: Number of buffered Bytes, which the LPR® station should send

Local-Address: LPR® Interface address (0.0.0.0 – listening to all interfaces)

Foreign Address: IP-address of opposite station

State: Status of connection

Example 2: - successful established connection

Proto	Recv-Q	Send-Q	Local-Address	Foreign Address	State
tcp	0	1	192.168.1.99:3045	192.168.1.1:1333	ESTABLISHED

Of Connection Type „TCP - Listening on Data Port“ (ttyAM1) is enabled this table shows further connection information.

Proto: Protocol (TCP, UDP)

Recv-Q: Number of buffered Bytes, which are received from the LPR® station

Send-Q: Number of buffered Bytes, which the LPR® station should send

Local-Address: LPR® Interface address (192.168.1.99) with port (3045)

Foreign Address: IP-address of opposite station (192.168.1.1) with port (1333)

State: Status of connection

6.5 Update Firmware

With this function you can update the firmware.

The firmware can be updated for example when a firmware with improved functional scope is available for the LPR® system.



But the system can also be irreparably damaged by a firmware update. Please make absolutely sure that the files are correct (file names and the version has been released by SYMEO), and proceed carefully and methodically. If the firmware update has not been carried out properly, or if problems arise of the system can no longer be accessed, contact Symeo Support.

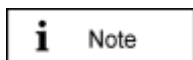

For FCC/IC authorization: Only firmware delivered for the U.S./ Candian market is allowed to install. Other firmware may violate the FCC/IC authorization.

⇒ Click "Firmware Update" in the navigation bar.

If you have not yet provided authentication information, you will be prompted to do so now.

The Firmware Update for the LPR® station's Web server is displayed.

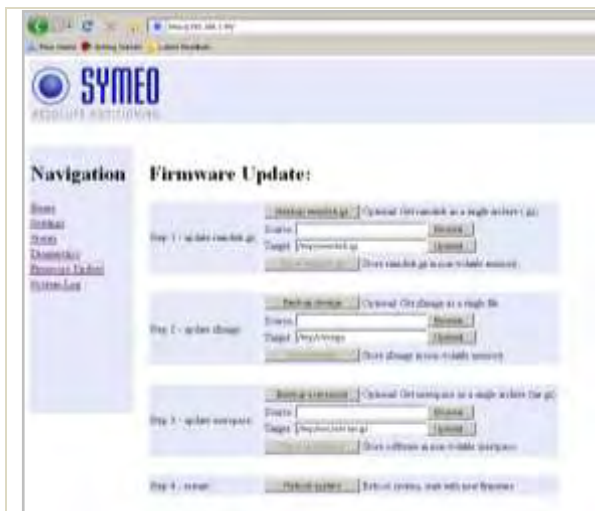

The page Firmware Update of the Web-Servers of the LPR® station is displayed.

A firmware update is performed in several steps:

Step 1: File system

Step 2: Linux-Kernel

Step 3: Optional (2D Application)

Step 4: Restart

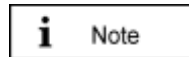

Note

Step 3 is exclusively for an update for 2D application. Otherwise this part can be skipped.

6.5.1 Step 1 – File system

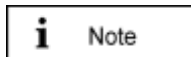

Note

It is possible to make a copy of the actual firmware by downloading the firmware from the LPR® station. Click the button „Backup ramdisk.gz“.

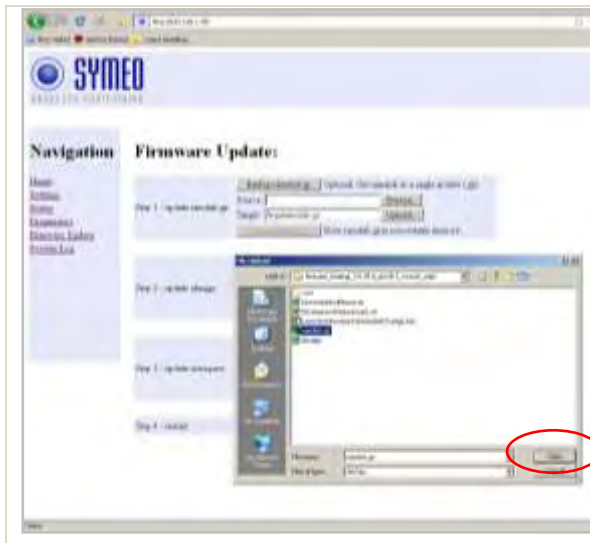

⇒ Click the "Browse" button in the "Step 1 – flash ramdisk.gz" area.

A file browser window will open.

⇒ Navigate to the file you want and click "Open".



⇒ Click the "Upload" button in the "Step 1 – flash ramdisk.gz" area.

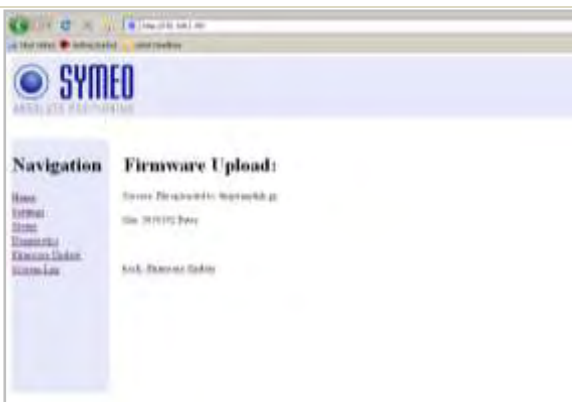

The file has been transferred.
⇒ Click the "back: Firmware Update" link.



⇒ Click the "Execute" button in the "Step 1 – flash ramdisk.gz" area to transfer the file to the non-volatile memory.



Transfer progress is displayed in a message window.

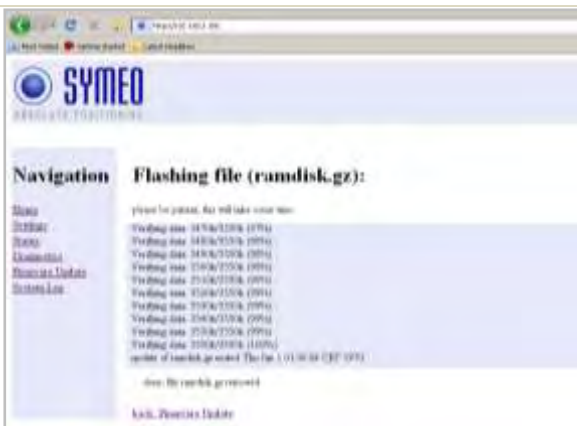

You will know when this operation is complete because a message: "... done, file ramdisk.gz removed" will be output and a link "back: Firmware Update" is provided

⇒ Click the "back: Firmware Update" link.

6.5.2 Step 2 – Linux Kernel

i Note

It is possible to make a copy of the actual firmware by downloading the firmware from the LPR® station. Click the button „Backup zImage“.



⇒ Click the "Browse" button in the "Step 2 – flash zImage" area.

A file browser window will open.

⇒ Navigate to the file you want and click "Open".



⇒ Click the "Upload" button in the "Step 2 – flash zImage" area.



⇒ The file has been transferred.
⇒ Click the "back: Firmware Update" link.



⇒ Click the "Execute" button in the "Step 2 – flash zImage" area to transfer the file to the non-volatile memory.



Transfer progress is displayed in a message window.



You will know when this operation is complete because a message: "... done, file zImage removed" will be output and a link "back: Firmware Update" is provided

⇒ Click the "back: Firmware Update" link.

6.5.3 Step 3 – Optional: Userspace

This step is exclusively for 2D-applications necessary and is executed the same way as described before.

6.5.4 Step 4 – Restart

To complete the firmware update, you must restart the system.

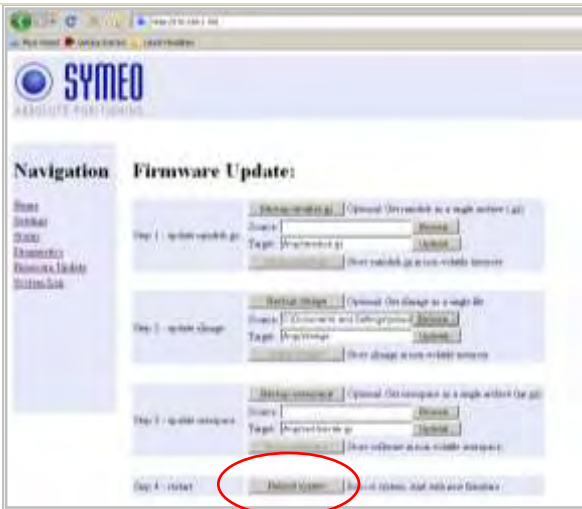

⇒ To do this, click the "Execute" button in the "Step 3 – Restart" button.

The system will be restarted.



i Note

If the new firmware contains additional configuration files the settings you made are set to factory settings. This would be also applied for the IP-address which is set to the default value 192.168.1.99.

Symeo recommends restoring the factory settings after a firmware update and reenter the customer settings.

6.6 System Log

With this function, you can display the system messages (system log). The system messages are written to a 200KB capacity memory. When the memory is full, the oldest messages are overwritten. All messages are deleted upon restart.

i Note

The system messages can also be transmitted to a server on the network at the same time, see the "Syslog" field in the "Network" area in section "Settings".



- ⇒ Click "System Log" in the navigation bar.
- ⇒ If you have not yet provided authentication information, you will be prompted to do so now (see chapter 6.1).

The last 10 system messages will be displayed. The message window is updated about once per second.

7 Protocol XP Description

7.1 General Description

This protocol describes the interface between a LPR® station and the user. The binary protocol XP protocol provides information in high density. Its structure ensures a simple implementation. The transfer is done in single data frames.

The interface for the binary protocol XP can either be a serial (RS232) interface or a TCP/IP or UDP interface. If the serial interface is chosen the data rate can be programmed to standard values (115200, 38400, 19200, 9600 baud). If a low data rate is chosen the measurement rate of the LPR® system may be adapted.

7.1.1 Direction of Data

The interface can be applied bidirectional. However certain data types are defined for one direction. Furthermore it is only allowed to send data to a LPR® station after the LPR® station has sent a send request. Table 1 shows an overview which data packets can be applied in which direction.

Data Type	direction	
	from	To
	LPR®	LPR®
0x00 Distance Data	+	
0x01 User Data	+	+
0x02 Send Request	+	
0x03 Relay Switching Command		+
0x04 6-Channel Distance Data Set	+	
0x05 Cell Coordinates	+	
0x06 Automatic Calibration		+

Tab. 1: direction of data

To send data to the LPR® station is only possible after receiving a send request (Type 0x02). The send request type guarantees the “ready-to-receive” status of the LPR® station. The LPR® can only handle one data packet from one user.

If nevertheless data is sent to the LPR® station without a previous send request, it can result in a reboot of the LPR® station.

Per one send request you can send one data set to the LPR® station.

7.1.2 Structure of Data Packet

To apply the protocol on a RS232 interface each data packet starts and ends with a reserved symbol. This reserved symbol cannot appear in the data stream.

Figure 1 shows the general structure of the data packet.

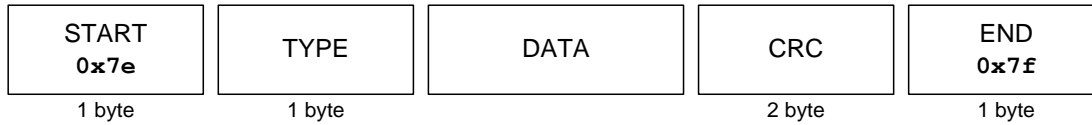

Figure 1: Structure of data the packet

The START and the STOP-field is in each data packet the reserved symbol 0x7e and 0x7f. TYPE indicates the type of the data packet. There can be defined up to 256 different types. The TYPE-field is following the DATA-field. The DATA field contains the real data of the packet of the type TYPE. The CRC-field contains a check sum. The check sum is applied to all previous data fields except the START data field.

All multi byte integers (e.g. CRC field) are encoded in Network-Byte-Order (Big Endian).

7.1.3 Byte Stuffing

The two symbols 0x7E and 0x7F are unique for START and STOP-fields. If those symbols occurs within any other field (TYPE, DATA or CRC), they must be replaced by the following order:

original symbol	replaced by
0x7D	0x7D 0x5D
0x7E	0x7D 0x5E
0x7F	0x7D 0x5F

This byte stuffing scheme ensures that the receiver of the protocol can identify definitely the START-field within a flow of data, even if the symbol of the start field occurs within the DATA-field.

Example: If the symbol 0x7d is read, it must be cancelled. The following symbol must be XOR combined with 0x20 to recreate the original symbol.

Remark: Byte stuffing is deactivated for the fixed frame protocol (compare chapter 7.3).

7.1.4 CRC

The CRC-16-IBM with polynomial $x^{16}+x^{15}+x^2+1$ is used for the CRC. The CRC is calculated over all data fields (TYPE and DATA), but not for the START and END field.

The CRC-calculation is only applied to the original symbols. The appropriate calculation for coding must applied before byte stuffing. If receiving the data from the LPR® system the byte stuffing must be reserved to get the original symbol. Then the CRC is updated with the original symbol.

7.2 Data Types

7.2.1 Type 0x00 – Distance Data

Direction: LPR® → User

Content	Length	Value	Data type
START	1	0x7E	
TYPE	1	0x00	
Source* (LPR® address 7.4.1)	2	0x#####	see chapter 7.4.1
Destination* (LPR® address 7.4.1)	2	0x#####	see chapter 7.4.1
Antenna number**	1	0x##	unsigned integer
Distance [mm]	4	0x#####	signed integer
Velocity [mm/s]	4	0x#####	signed integer
Level [dB]	1	0x##	signed integer
Error	1	0x##	unsigned integer
Status	1	0x00	unsigned integer
CRC	2	0x#####	
END	1	0x7F	

Total length without byte stuffing: 21 byte

*) Any measurement is always executed by a LPR® base station, this means, the base station measures its distance etc. towards a transponder unit. The source field always contains the address of the LPR® base station. The destination field contains the address of the measured transponder. Even if the data set is transferred further on to another unit (e.g. another transponder), the value of the source and destination field is maintained.

**) The field antenna contains the antenna number of the base station as well as the antenna number of the measured transponder. The 4 lower bits represent the antenna number of the base station (values 1..4) and the higher ones the antenna number of the transponder (values 1..4).

7.2.2 Example of Distance Data

```
7E 02 C1 81 7F
7E 00 08 03 08 02 11 00 00 10 62 00 00 00 7A E6 00 00 AF C4 7F
```

Figure 43 - Protocol for a single 1D measurement: request data and following distance data

This protocol shows a simple example for 1D measurement. A distance data set (or also 2 distance data sets) alternate with a send request. The Send Request indicates that the LPR® unit is listening to a data set from the user (for example relays external commands). The Distance Data sends the data to the user (i.e. to a PLC or to a PC/software).

Send request:

```
7E 02 C1 81 7F
```

7E_{hex} START byte
 02_{hex} TYPE (02; Send Request)
 C1 81_{hex} cyclic redundancy check
 7F_{hex} END byte

Distance data:

```
7E 00 08 03 08 02 11 00 00 10 62 00 00 00 7A E6 00 00 AF C4 7F
```

7E_{hex} START byte
 00_{hex} TYPE (00: Distance Data)
 08 03_{hex} = 00001|0000000001|1_{bin} Source LPR® address: GID: 1; SID: 1; BBt: 1
 (master unit/transponder)
 08 02_{hex} = 00001|0000000001|0_{bin} Destination LPR® address: GID: 1; SID: 1; BBt: 0
 (slave unit/ base station)
 11_{hex} = 0001|0001_{bin} Antenna port base station: 1 antenna port transponder: 1
 00 00 10 62_{hex} = 4194_{dec} Distance: 4194 mm
 00 00 00 7A_{hex} = 122_{dec} Velocity: 122 mm/s
 E6_{hex} = 230_{dec} Level: 230 – 256 = -26 dB
 00_{hex} Error status: 0 means no error; unequal 0 means error
 00_{hex} Status
 AF C4_{hex} cyclic redundancy check
 7F_{hex} END byte

7.2.3 Type 0x01 – User Data

Direction: LPR® → User

Content	Length	Value
START	1	0x7E
TYPE	1	0x01
Source (LPR® address ^{7.4.1})	2	0x#####
User Data	8	0x##### ##### ##### #####
CRC	2	0x#####
END	1	0x7F

Total length without byte stuffing: 15 byte

User data can be integrated at a LPR® station and can be transmitted via the frequency channel to another LPR® station.

7.2.4 Type 0x02 – Send Request

Direction: LPR® → User

Content	Length	Value
START	1	0x7E
TYPE	1	0x02
CRC	2	0xC181
END	1	0x7F

Total length without byte stuffing: 5 byte

The user may only send a data frame after receiving a send request.

7.2.5 Type 0x03 – Relays Switching Command

Direction: User → LPR®

Content	Length	Value	Data type
START	1	0x7E	
TYPE	1	0x03	
Destination (LPR® address ^{7.4.1})	2	0x#####	see chapter 7.4.1
Relay Selection (Bitmask) (bit 1..7 → relay 1..7)	1	0x##	unsigned integer
Relay Switch (Bitmask)	1	0x##	unsigned integer
CRC	2	0x#####	

END	1	0x7F	
-----	---	------	--

Total length without byte stuffing: 9 byte

Via the relay selection (bitmask) you set the relays which can be controlled. The relays chosen within the Relay Selection bitmask will be switch according to the Relay Switch bitmask (e.g. a Relay Selection value = $0x14_{hex} = 00010100_{bin}$ and a Relay Switch value = $0xFF_{hex} = 11111111_{bin}$ will switch relays 2 and 4 ON - the state of the other relays remains unchanged).

No acknowledgment of the relay switch command will be sent because this data frame can be forwarded to other LPR® stations and thus no reception on the destination station is guaranteed. In case of faulty data frame (e.g. invalid relays chosen or unknown destination address) the LPR® station will print an error message.

7.2.6 Type 0x04 – 6 Channel Distance Data Set

Direction: LPR® → User

Description	Length	Value	Data type
START	1	0x7E	
TYP	1	0x04	
Source* (LPR® address 7.4.1)	2	0x#####	See chapter 7.4.1
Antenna number**	1	0x##	unsigned integer
Group	2	0x#####	unsigned integer
Measurement Channel 0***	12		see below
Measurement Channel 1	12		see below
Measurement Channel 2	12		see below
Measurement Channel 3	12		see below
Measurement Channel 4	12		see below
Measurement Channel 5	12		see below
Age of Measurement [µs]	4	0x#####	unsigned integer
Status	1	0x00	
CRC	2	0x#####	
END	1	0x7F	

Total length without byte stuffing: 87 byte

*) Source field see chapter 7.2.1

**) Antenna number contains the number of the antenna of the slave station/ base station (values: 1...4)

***) The measurement of the single channels is similar to the distance data set (see chapter 7.2.1):

Distance [mm]	4	0x#####	signed integer
---------------	---	---------	----------------

Velocity [mm/s]	4	0x#####	signed integer
Attenuation [dB]	1	0x##	signed integer
Error	1	0x##	unsigned integer
Quality Criterion	2	0x#####	unsigned integer

7.2.7 Type 0x05 –Coordinates of cell

Direction: LPR® → User

Content	Length	Value
START	1	0x7E
TYP	1	0x05
Source*	2	0x#####
Number of transponders per cell**	1	0x##
Independent coordinate system***	1	
Measurement channel****	1	
x - coordinate [mm]	4	signed
y - coordinate [mm]	4	signed
Altitude [mm]	2	signed
x - direction vector	1	signed
y – direction vector	1	signed
Aperture angle of antenna [°]	2	unsigned
CRC	2	0x#####
END	1	0x7F

Total length without byte stuffing: 24 byte

This data set is sent for each transponder per cell.

*) Source field: The source type is a matter of the LPR® address of the master unlike the other message types.

***) maximum of 6 transponders per cell

****) The coordinate system indicates if the cell has an own coordinate system (1) with no fixed relation to another cell or if the cell is a part of a superior coordinate system, which consists of multiple cells (0). This is important for the demonstration in SYMEO Map.

*****) The measurement channel (0..5) is consistent with the station ID of the appropriate transponder.

7.2.8 Type 0x06 – Automatic Calibration

Direction: User → LPR®

Content	Length	Value
START	1	0x7E
TYP	1	0x06
Source	2	0x####
Number of measurement	2	0x####
Flags*	2	0x0000
CRC	2	0x####
END	1	0x7F

Total length without byte stuffing: 11 Byte

The packet starts a series of measurements between the transponders of a cell. The results are sent as 6-channel distance data set (type 0x04).

*) Flags: for future expansion, at the moment always zero

7.3 TCP/IP option: Fixed Frame Protocol

If the LPR® station has a TCP/IP interface two options are available for the protocol. Either you use the protocol as it is sent from the serial interface (with different data type lengths, byte stuffing) or you use a fixed frame protocol.

In the first case the data symbols 0x7e und 0x7f (which are reserved for the START and END field) are replaced (see chapter 7.1.3). Byte stuffing causes a different protocol length.

For the fixed frame protocol each LPR® data packet is filled up with zero bytes to a fixed length of bytes (i.e. 87 bytes) before the data packet is sent. Byte stuffing does not occur. The START and the END byte are still used but not clear anymore due to not applying byte stuffing. The fixed length of the data packets can be set on the web-interface of the LPR® unit.

For the fixed frame protocol the data packets which are sent to a LPR® unit has to be filled up to a fixed length (i.e. 15 bytes). The START- and the END byte have to be occurred as well and byte stuffing does not occur anymore. It is recommended to fill up the data packet with zero bytes to facilitate a troubleshooting.

If TCP/IP is used the transmitted data have already a checksum. Therefore the checksum in the protocol is not as important as for the serial interface. Two options for the fixed frame are allowed by the protocol inverter for receiving data in a fixed frame. Either 0x0000 is sent as the check sum to the LPR® unit. Then the protocol inverter is calculating the check sum itself. Or another value (differing to 0x0000) is sent as the check sum. Then this check sum is assumed to be the correct check sum. Otherwise the data packet is rejected.

7.3.1 Detailed description TCP Fixed-Frame Protocol

If a TCP fixed-frame protocol is used, a working TCP connection between the PC and the LPR® unit has to be guaranteed. Depending on the configuration of the LPR® protocol inverter either the connection to a port on the LPR® has to be initialized from the PC or the LPR® unit is establishing a connection to a PC.

If the connection is established, the PC has to read the data from the LPR® in fixed data length (i.e. 87 bytes). The first byte is always the START-byte and the second byte is always the TYPE-byte. The relevance of the following data is depending on the data type. Because no byte stuffing occurs the content for a special data type is always constant. For example the measured velocity of the distance data (type 0x00) is always written in the 12.-15 data byte.

Sending data from the PC to LPR® station, a fixed data length has to be chosen (i.e. 15 bayted). The first byte (START byte: 0x7e) follow the TYPE-byte. The following data depends on the chosen type, following by the CRC (correct CRC or 0x0000), following by the STOP byte (0x7f). The data packed has to be filled up with zeros.

Detailed description UDP Fixed-Frame Protocol

If a UDP fixed frame protocol is used, the IP and the UDP port of the PC has to be configured in the LPR® protocol inverter. The converter sends each data packet as a UDP packet of a fixed length (87 byte) to the PC. Compared to the TCP fixed frame option the UDP fixed frame does not verify if the data packed arrived.

The content is the same as for the TCP fixed frame protocol.

If data is sent to the LPR® unit the data has to be packed in a fixed data length (i.e. 15 bytes as for TCP fixed frame option). This data packet is sent as UDP packet to the LPR® unit. The port number of the receiver is the same as for the PC.

In general bidirectional data communication is not recommended for UDP due to loosing singular data packets.

7.4 Remarks

7.4.1 LPR® Address

LPR® station addresses are completely defined by a 16 bit value:



BB – Base station Bit:	Indicates, if the LPR® station is defined as a slave unit/ base station or as a master unit/ transponder (1=base station, 0=transponder)
group ID:	group ID of the station (1..1022)
station ID:	station ID of the station (0..30)

7.4.2 Error messages

The distance data contains an error field which indicates the status of the message. The following errors can occur:

Content	Source	Description	Value
no error		Measurement valid	0x00
no peak detected	Base Station	No measurement signal	0x01
peak too low	Base Station	Measurement signal is imprecise	0x02
nothing received	Transponder	No measurement data received	0x03
implausible speed	Base Station	Velocity is to high	0x04
measurement botched	Base Station	Measurement is not feasible.	0x05
no occupying received	Master Transponder	Measurement channel is not reserved	0x06
no results received	Master Transponder	No measurement data received	0x07
trigger	Transponder	Unit did not attend the measurement	0x08

8 Appendix A: Agency certifications

8.1 United States (FCC) and Canada (Industry Canada)

Radiofrequency radiation exposure Information:

This equipment complies with FCC/IC radiation exposure limits set forth for an uncontrolled environment. This equipment should be installed and operated with minimum distance of 20 cm between the radiator and your body.

This transmitter must not be co-located or operating in conjunction with any other antenna or transmitter.

i Note

Changes or modifications made to this equipment not expressly approved by SYMEO GmbH may void the FCC/IC authorization to operate this equipment.

i Note

This device complies with Part 15 of the FCC Rules and with RSS-210 of Industry Canada.

Operation is subject to the following two conditions:

- ⇒ this device may not cause harmful interference, and
- ⇒ this device must accept any interference received, including interference that may cause undesired operation.

i Note

A direct connection between the power supply unit and AC power line is strictly prohibited. A line filter (e.g. EPCOS B84113-C-B30 or similar characteristics) shall be used to connect the power supply unit and AC power line.

i Note

Installation:

All installation, repair and servicing work must be carried out by qualified and trained technicians!

Repairs:

Repairs to the device must be carried out by authorized technicians.

Unauthorized opening and incorrect repairs could result in severe danger to the user (danger of electric shock, radiated energy, fire hazard).

8.2 United States (FCC)

i Note

This equipment has been tested and found to comply with the limits for a Class B digital device, pursuant to Part 15 of the FCC Rules. These limits are designed to provide reasonable protection against harmful interference in a residential installation. This equipment generates, uses and can radiate radio frequency energy and, if not installed and used in accordance with the instructions, may cause harmful interference to radio communications. However, there is no guarantee that interference will not occur in a particular installation. If this equipment does cause harmful interference to radio or television reception, which can be determined by

turning the equipment off and on, the user is encouraged to try to correct the interference by one or more of the following measures:

- ⇒ Reorient or relocate the receiving antenna.
- ⇒ Increase the separation between the equipment and receiver.
- ⇒ Connect the equipment into an outlet on a circuit different from that to which the receiver is connected.
- ⇒ Consult the dealer or an experienced radio/TV technician for help

i Note

This device has been designed to operate with the antennas listed below. Antennas not included in this list are strictly prohibited for use with this device. Only antenna cables delivered by Symeo are allowed to use. Usage of other antenna cables may void the FCC authorization to operate this equipment.

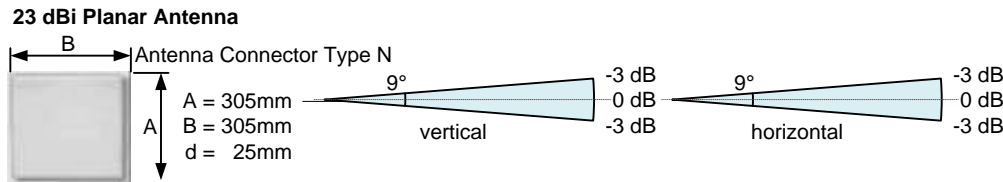

Figure 44: LPR® 1D antenna

8.3 Canada (Industry Canada)

i Note

This Class [B] digital apparatus complies with Canadian ICES-003. Cet appareil numérique de la classe [B] est conforme à la norme NMB-003 du Canada.

i Note

This device has been designed to operate with the antennas listed below and having a maximum gain of 23 dBi. Antennas not included in this list or having a gain greater than 23 dBi are strictly prohibited. The required impedance for antenna and antenna cable is 50 ohms. Only antenna cables delivered by Symeo are allowed to use. Usage of other antenna cables may void the IC authorization to operate this equipment.

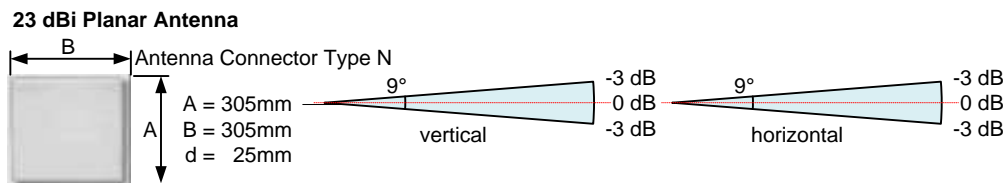

Figure 45: LPR® 1D antenna