

# Voyager® Digital Wireless Auto-Pairing

FEATURING  
**WiSight®** technology

## WVOS43 Digital Wireless Observation System



### KEY FEATURES:

- Easy installation, fits most applications
- 4.3" monitor comes with suction cup mount and 12 Volt DC plug for easy portability
- Camera connects to rear clearance light or 12V circuit
- WiSight® technology- no cable or wiring necessary
- No interference
- Signal transmits through and around objects up to 60+ feet away
- Sharp, clear, uninterrupted picture
- Expandable up to four wireless cameras (WVCMS130AP) and one Voyager wired camera
- Mirror or Normal View selectable

### YOU WILL NEED:

- Voltage Meter
- Water proof sealant
- Drill with 1/8" drill bit
- Phillips head screwdriver

Package includes a 4.3" LCD color monitor, one 12 Volt DC accessory plug, one wired camera cable input, a suction cup monitor mount, one rear color camera, stainless steel hardware, and non-corrosive camera mounting bracket.

**PATENT PENDING**

English

# INSTALLING THE CAMERA

1. Choose a location close to the rear clearance lights so you can easily splice the power and ground connections.
2. Using a voltage meter, measure the clearance light wiring to determine positive/negative polarity.
3. Connect the red wire from the camera to the positive wire in the rear clearance lights.
4. Connect the black wire from the camera to the negative wire in the rear clearance lights.
5. Pre-drill the screw holes for the mounting bracket with an 1/8" drill bit.
6. Apply a weather proof sealant to the pre-drilled holes.
7. Align the bracket to the holes.
8. Install the bracket with the supplied Tapping P/H screws with washers.
9. Apply additional sealant to the screw heads and bracket to ensure a weather proof seal.
10. Align the camera in the bracket (Figure 1).
11. Install with the supplied Hex Socket Head stainless screws and larger washers in the corresponding holes(Figure 2).
12. Camera should be adjusted for optimum view before these screws are fully tightened.

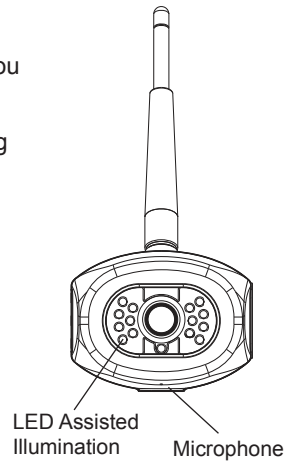

**Installation**

Screw For Use

- Hex socket Head M4xM6L stainless screw
- Flat washers 4.5x9.5x1mm
- Stainless Allen wrench

**Figure 2**

**Figure 1**

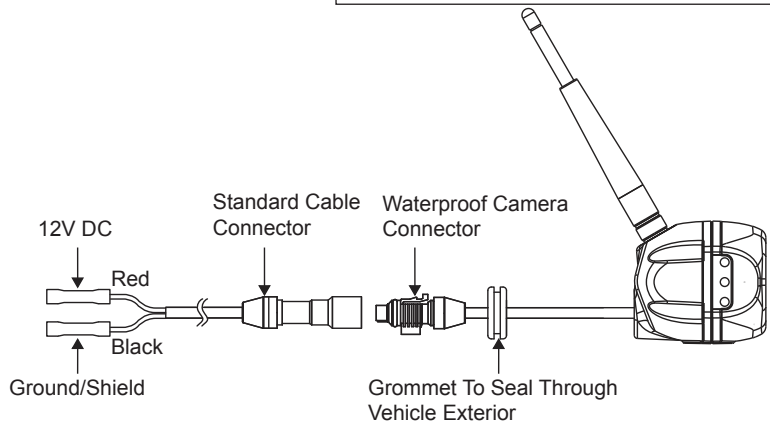

## INSTALLING THE MONITOR

1. Plug power cable into the back of the monitor.
2. Attach the suction cup mount to the rear of the monitor with the supplied bracket.
3. Locate flat section of glass on your windshield (that does not block your vision) and apply suction cup. Snap the lever into the locked position (Figure 5).
4. Connect the power cord to a 12 Volt DC outlet.
5. Align the antenna to its upright position, parallel to the monitor.

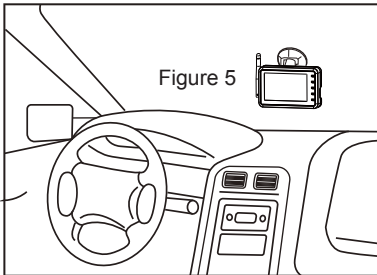

## OPERATION

1. Press the power button on the monitor and turn on your vehicle's parking lights.
2. In the top left corner of the monitor, you will see the signal strength meter.
3. Adjust the suction cup bracket to provide the best viewing angle.

## PAIRING PROCESS

This system has Auto-Pairing function. If your monitor is not receiving a signal from the camera; the two may not be paired correctly.

1. Monitor must be connected to 12 Volt DC power supply.
2. Press the SELECT/PAIR button on the front of the monitor expected mode & select the appropriate AV source (AV1-AV4)
3. Press and hold the "SELECT/PAIR" button on the front of the monitor for 5 seconds and release. (Monitor will display "PAIRING START")
4. Apply 12 Volt DC power to the camera.(Camera 1 - Camera 4 corresponding to Monitor's AV1 - AV4)

If done correctly, monitor will display "SAVE DATA". If pairing is not successful, the monitor will display "PAIRING FAIL". If you receive this message, repeat steps 3-4.

# KEY FUNCTION

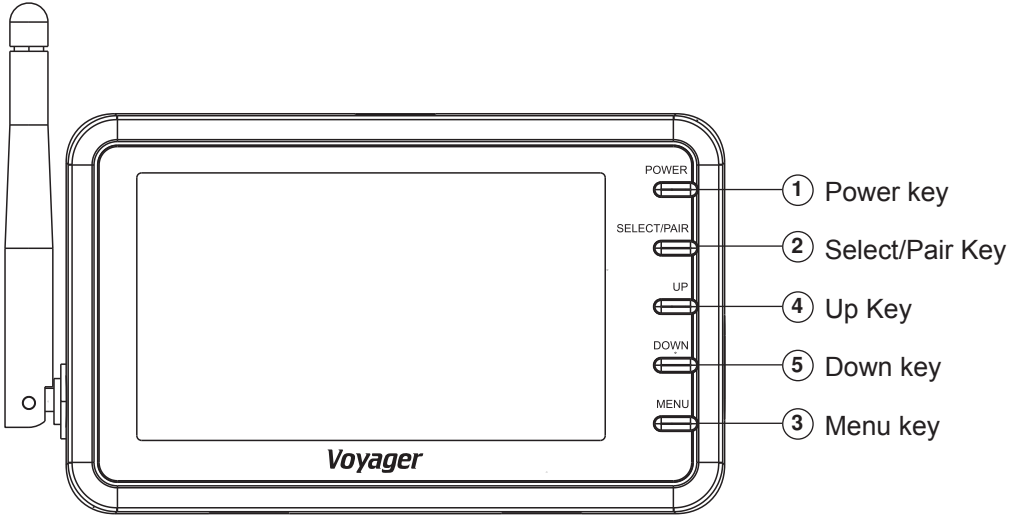

## 1. POWER KEY

- Press once to turn on the monitor.
- Press again to turn off the monitor.

## 2. SELECT/PAIR KEY

- Press the SELECT/PAIR key less 1 second, the channel will be changed.
- Press the SELECT/PAIR key over 5 seconds, the pairing mode is enabling.

## 3. MENU KEY

- Press less than 1 second enters the Contrast, Brightness, Color, Tint, Mirror, AutoPower, Dimming, Screen Saver and Scale Marker adjustment mode.
- Press the up or down key to adjust the level of menu.

Contrast

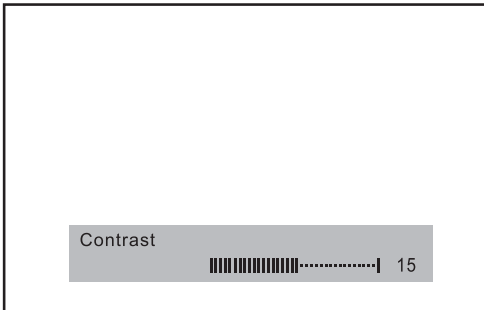

Brightness

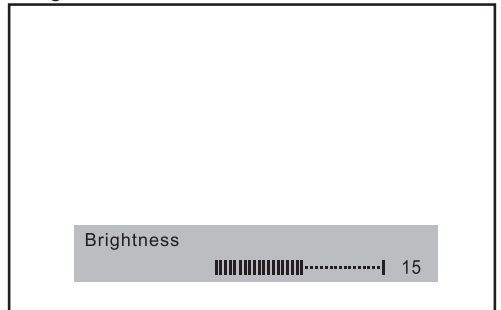

Color

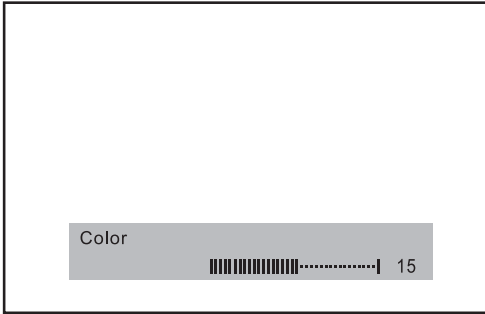

Tint

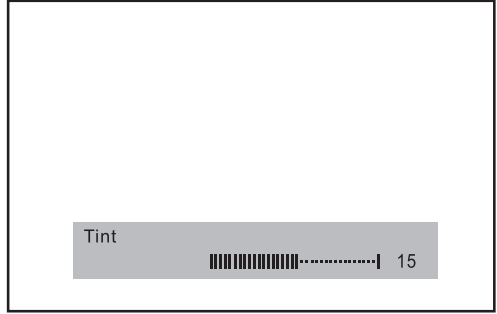

Mirror

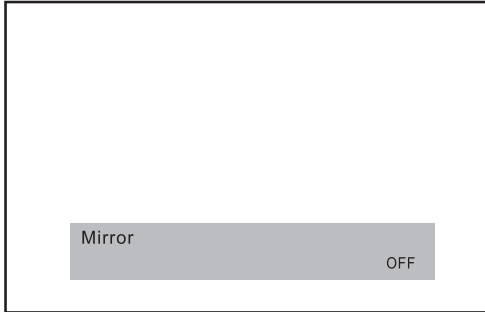

AutoPower

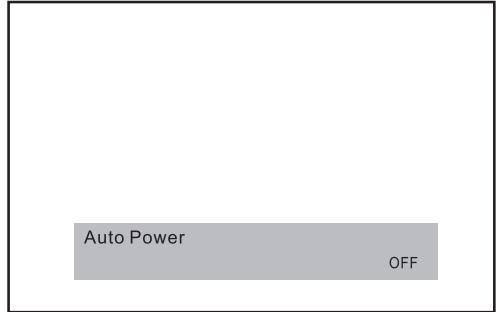

Dimming

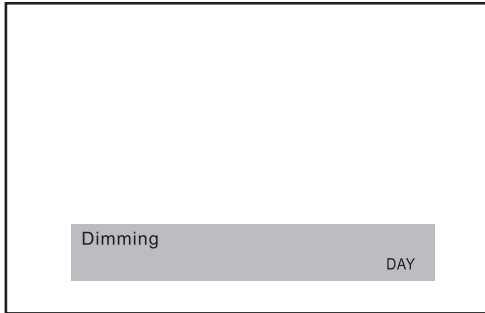

Screen Saver

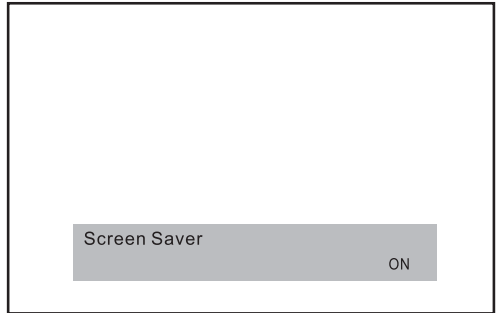

Scale Marker

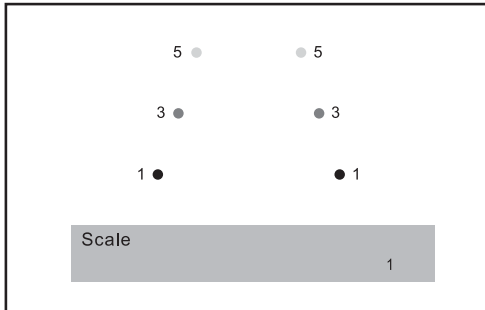

## **4.UP AND 5.Down KEYS**

### **Function for Brightness, Contrast, Color, and Tint Control**

- Pressing “UP” key to increases brightness, contrast, color, or tint level when accessed menu adjust mode.
- Pressing “DOWN” key to decreases brightness, contrast, color, or tint level when accessed menu adjust mode.

### **Function for Mirror Control**

- Pressing “UP” key to change the mirror setting to ON or OFF when accessed menu adjust mode.
- Pressing “DOWN” key to change the mirror setting to OFF or ON when accessed menu adjust mode.

### **Function for AutoPower**

- Pressing “UP” key to change the Autopower setting to ON or OFF when accessed menu adjust mode.
- Pressing “DOWN” key to change the Autopower setting to OFF or ON when accessed menu adjust mode.

Note:

- Auto power on - The system automatically returns to a power on state when switch on.
- Auto power off - The system automatically returns to a power off state when switch on.

### **Function for Dimming**

- Pressing “UP” key to change the Dimming setting to DAY or NIGHT when accessed menu adjust mode.
- Pressing “DOWN” key to change the Dimming setting to DAY or NIGHT when accessed menu adjust mode.

Note:

- The luminance is 100% when DAY mode.
- The luminance is 50% when NIGHT mode.

### **Function for Screen Saver**

- Pressing “UP” key to change the Screen Saver setting to ON or OFF when accessed menu adjust mode
- Pressing “DOWN” key to change the Screen Saver setting to OFF or ON when accessed menu adjust mode.

Note:

- The luminance is 10% when Screen Saver ON.
- The screen saver will run when no any key is presses within 1 minute.
- The luminance will back to DAY or NIGHT when press any key.

### Function for Scale Marker

- Press "UP" or "DOWN" to change the Scale Marker mode.

1.OFF mode

2. Mode1

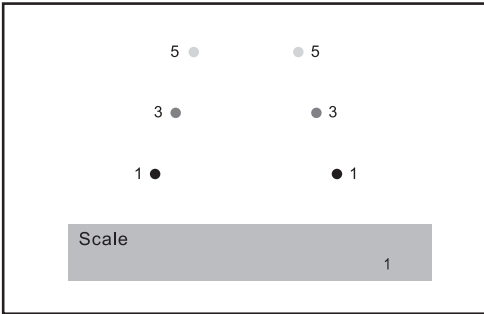

3. Mode 2

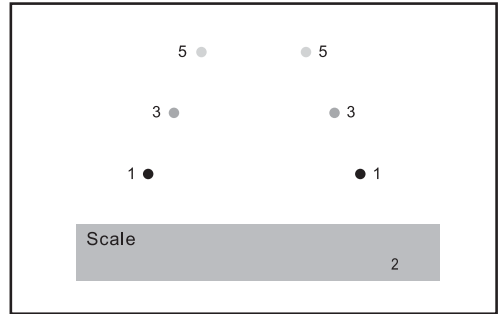

4. Mode 3

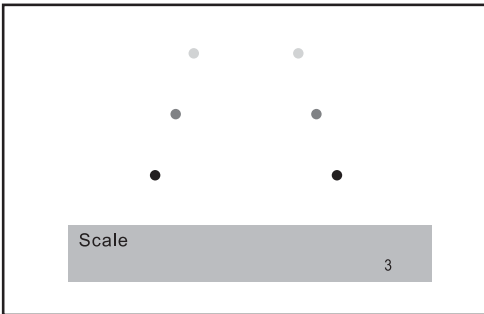

5. Mode 4

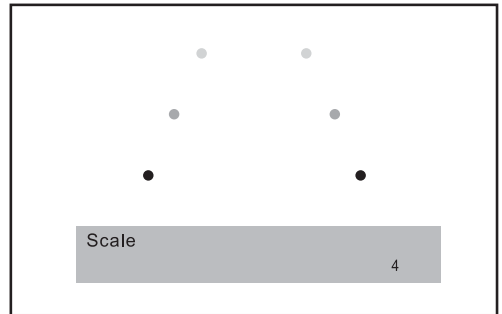

### Function for Speaker Volume Control

- Pressing "UP" key to increases volume level.

- Pressing "DOWN" key to decreases volume level.

Volume

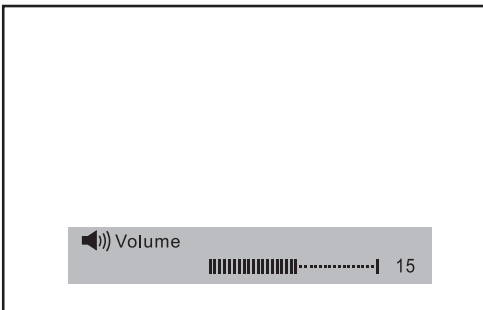

## **FCC IMPORTANT NOTE:**

### **15.105(b)**

This equipment has been tested and found to comply with the limits for a Class B digital device, pursuant to part 15 of the FCC rules. These limits are designed to provide reasonable protection against harmful interference in a residential installation.

This equipment generates, uses and can radiate radio frequency energy and, if not installed and used in accordance with the instructions, may cause harmful interference to radio communications. However, there is no guarantee that interference will not occur in a particular installation. If this equipment does cause harmful interference to radio or television reception, which can be determined by turning the equipment off and on, the user is encouraged to try to correct the interference by one or more of the following measures:

- Reorient or relocate the receiving antenna.
- Increase the separation between the equipment and receiver.
- Connect the equipment into an outlet on a circuit different from that to which the receiver is connected.
- Consult the dealer or an experienced radio/TV technician for help.

### **15.21**

You are cautioned that changes or modifications not expressly approved by the part responsible for compliance could void the user's authority to operate the equipment.

To comply with the FCC RF exposure compliance requirements, the antenna(s) used for this transmitter must be installed to provide a separation distance of at least 20 cm from all persons and must not be co-located or operating in conjunction with any other antenna or transmitter. No change to the antenna or the device is permitted.

Any change to the antenna or the device could result in the device exceeding the RF exposure requirements and void user's authority to operate the device.

### **CAMERA-MONITOR WARNINGS!**

1. Camera/Monitor system aids in the use of, but does not replace vehicle side/rear-view mirrors.
2. Objects in Camera/Monitor view are closer than they appear.  
When backing up, processed cautiously and be prepared to stop.

### **NOTICE 1 :**

The changes or modifications not expressly approved by the party responsible for compliance could void the user's authority to operate the equipment.

### **NOTICE 2:**

Our WiSight wireless technology operates at nearly the same performance level as a wired system. However, slight delays and signal reductions are possible due to application or environmental factors.

It is recommended to maintain at least three feet in between any RF transmitting/receiving devices including the WiSight components. This can include, but not limited to, in-vehicle Wi-Fi systems, personal Wi-Fi hotspots, Bluetooth devices or additional wireless monitors & cameras.

If you have a Voyager WiSight Digital Wireless Observation System along with any other



device that transmits or receives and you are experiencing difficulty in operating the system, the device(s) may be too close to either the WiSight Monitor or Camera.

Change the placement to at least three feet between devices and re-test for proper operation.

## **TROUBLE SHOOTING**

Monitor will not turn on.

- Check power cord connection at monitor and 12VDC socket.
- Check fuse in cigarette socket adapter.

---

Monitor displays "No Signal".

- Check 12VDC power at camera.
- Make sure antenna is tight and pointed correctly.
- Make sure monitor is set to AV1.
- Try manually pairing the system. see pairing Process for instructions.

---

Intermittent reception.

- Make sure antenna is tight and installed vertically.
- 

Features and specifications subject to change with out notice  
For further technical support call: 1-877-305-0445