

# 2151 Low Profile Photoelectronic Plug-in Smoke Detector



3825 Ohio Avenue, St. Charles, Illinois 60174  
1-800-SENSOR2, FAX: 630-377-6495  
www.systemsensor.com

## Specifications

Size	
Height:	1.7 inches (43 mm)
Diameter:	4.0 inches (101 mm)
Weight:	3.6 oz. (102 g)
Operating Temperature Range:	0°C to 49°C (32°F to 120°F)
Operating Humidity Range:	10% to 93% Relative Humidity noncondensing
Latching Alarm:	Reset by momentary power interruption.

## Before Installing

Please thoroughly read the System Sensor manual A05-1003, *Applications Guide for System Smoke Detectors*, which provides detailed information on detector spacing, placement, zoning, wiring, and special applications. Copies of this manual are available from System Sensor.

**NOTICE:** This manual should be left with the owner/user of this equipment.

**IMPORTANT:** The detector used with this base must be tested and maintained regularly following NFPA 72 requirements. The detector used with this base should be cleaned at least once a year.

## General Description

The 2151 low-profile photoelectronic detector uses a state-of-the-art optical sensing chamber. This detector is designed to provide open area protection and to be used with compatible UL listed control panels only. The capability of plugging this detector into a variety of special bases makes it more versatile than equivalent direct-wired models.

Two LEDs on each detector provide local 360° visible alarm indication. They flash every ten seconds indicating that power is applied and the detector is working properly. The LEDs latch on in alarm. Remote LED annunciator capability is standard and may be implemented through an optional accessory RA400Z. The alarm can be reset only by a momentary power interruption. This detector may be tested by activating the internal reed switch with a magnet.

## Base Selection And Wiring Guide

Refer to the installation instructions for the Plug-in Detector Bases for base selection and wiring instructions. System Sensor has a variety of detector bases available for

this smoke detector, including 2-wire applications with and without relays and/or current limiting resistors, 4-wire and 120VAC applications.

All bases are provided with screw terminals for power, ground, remote annunciator connections and relay contact connections, if applicable. The electrical ratings for each detector-base combination are also included in the base installation instructions.

## Installation

**NOTE:** All wiring must conform to applicable local codes, ordinances, and regulations.

**NOTE:** Verify that all detector bases are installed, that the initiating-device circuits have been tested, and that the wiring is correct. (Refer to detector base manual for testing procedure.)



Remove power from initiating-device circuits before installing detectors.

1. Install detectors:
  - a. Place the detector into the detector base.
  - b. Turn the detector clockwise until the detector drops into place.
  - c. Continue turning detector clockwise to lock it in place.
2. Tamper Resistance: The detector bases can be made tamper resistant. When capability is enabled, detectors cannot be removed from the base without the use of a tool. See the detector base installation manual of the detector base for details in using this capability.
3. After all detectors have been installed, apply power to the control unit.

4. Test the detector using the magnet as described under TESTING.
5. Reset the detector at the system control panel.
6. Notify the proper authorities that the system is back on line.

**CAUTION**

Dust covers are an effective way to limit the entry of dust into smoke detector sensing chambers. However, they may not completely prevent airborne dust particles from entering the detector. Therefore, System Sensor recommends the removal of detectors before beginning construction or other dust producing activity.

Be sure to remove the dust covers from any sensors that were left in place during construction as part of returning the system to service.

**CAUTION**

Smoke detectors are not to be used with detector guards unless the combination has been evaluated and found suitable for that purpose.

**Testing**

Before testing, notify the proper authorities that the smoke detector system is undergoing maintenance and will temporarily be out of service. Disable the zone or system undergoing maintenance to prevent unwanted alarms. Detectors must be tested after installation and as part of periodic maintenance. Test the 2151 as follows:

**NOTE:** Before testing the detector, check to ensure the LEDs blink. If they do not, the detector has lost power (check the wiring) or it is defective (return it for repair).

- A. Test Magnet (p/n M02-04-01 or M02-09-00)
  1. Place the magnet against the cover in the location designated by the raised mark to activate the test feature (see Figure 1).
  2. The LEDs should latch ON within 5 seconds indicating alarm and annunciating the panel.

- B. Test Module ( MOD400R)
 

Use the MOD400R with a DMM or voltmeter to check the detector sensitivity as described in the MOD400R manual.

- C. Aerosol Generator (Gemini 501)
 

Set the generator to represent 4% to 5% /ft. obscuration as described in the Gemini 501 Manual. Using the bowl-shaped applicator, apply aerosol until unit alarms.

Notify the proper authorities that the system is back on line.

Detectors that fail these tests should be cleaned as described under MAINTENANCE and retested. If the detectors still fail these tests, they should be returned for repair.

**Maintenance**

It is recommended that the detector be removed from its mounting base to facilitate cleaning. The detector is cleaned as follows:

**NOTE:** Before removing the detector, notify the proper authorities that the smoke detector system is undergoing maintenance and will be temporarily out of service. Disable the zone or system undergoing maintenance to prevent unwanted alarms.

**Figure 1. Bottom and side views showing position of test magnet:**

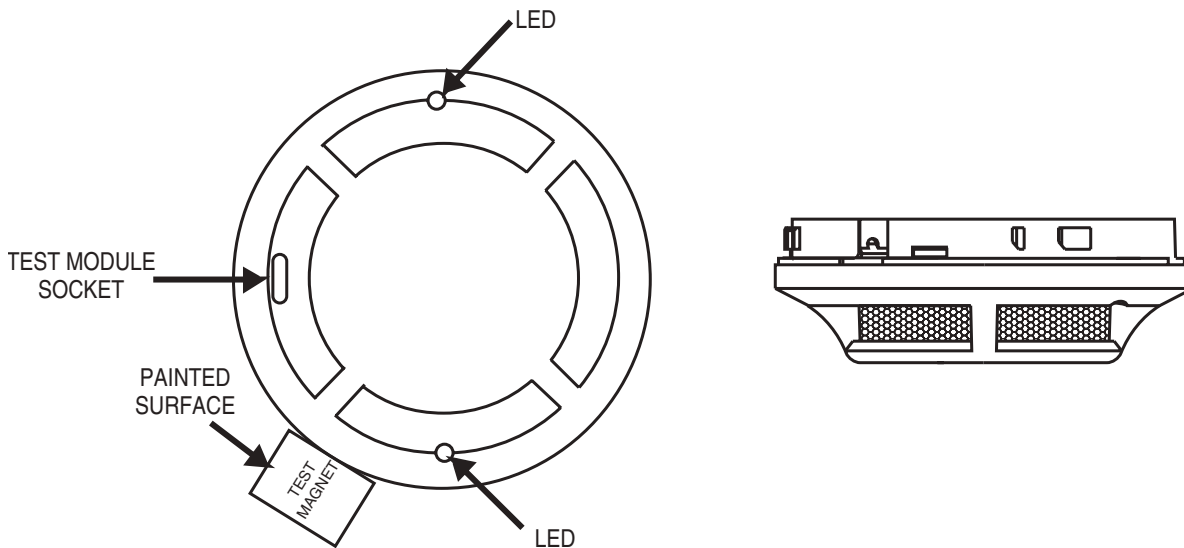

C0627-00

1. Remove the detector cover by prying away the four side tabs with a small-bladed screwdriver, and then pulling the cover from the base.
2. Vacuum the screen carefully without removing it. If further cleaning is required continue with Step 3, otherwise skip to Step 8.
3. Remove the screen assembly by pulling it straight out (see Figure 2).
4. Remove the sensing chamber cover by pulling it straight out.
5. Clean the vaned chamber piece by vacuuming or blowing out dust and particles.
6. Replace the sensing chamber cover, aligning the arrow on the top with arrow on the printed circuit board.
7. To replace the screen, place it over the chamber assembly, turning it until it snaps into place.
8. Replace the cover using the test module socket and LEDs to align the cover and then gently pushing it until it locks into place.
9. Reinstall the detector.
10. Test the detector as described in TESTING.
11. Reconnect disabled circuits.
12. Notify the proper authorities that the system is back on line.

**Figure 2:**

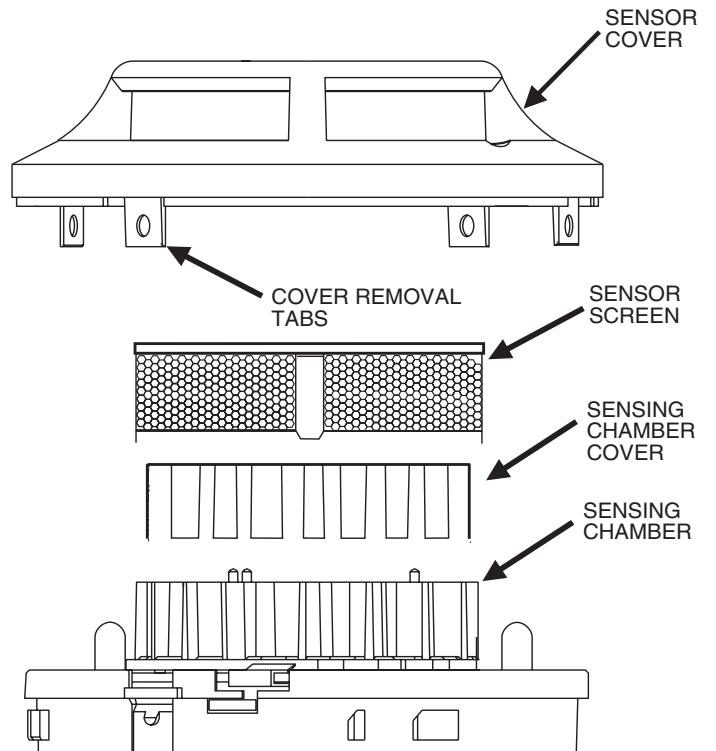

C0253-00

**Special Note Regarding Smoke Detector Guards**

Smoke detectors are not to be used with detector guards unless the combination has been evaluated and found suitable for that purpose.

**Please refer to insert for the Limitations of Fire Alarm Systems**

**Three-Year Limited Warranty**

System Sensor warrants its enclosed smoke detector to be free from defects in materials and workmanship under normal use and service for a period of three years from date of manufacture. System Sensor makes no other express warranty for this smoke detector. No agent, representative, dealer, or employee of the Company has the authority to increase or alter the obligations or limitations of this Warranty. The Company's obligation of this Warranty shall be limited to the repair or replacement of any part of the smoke detector which is found to be defective in materials or workmanship under normal use and service during the three year period commencing with the date of manufacture. After phoning System Sensor's toll free number 800-SENSOR2 (736-7672) for a Return Authorization number, send defective units postage prepaid to: System Sensor, Repair

Department, RA # \_\_\_\_\_, 3825 Ohio Avenue, St. Charles, IL 60174. Please include a note describing the malfunction and suspected cause of failure. The Company shall not be obligated to repair or replace units which are found to be defective because of damage, unreasonable use, modifications, or alterations occurring after the date of manufacture. In no case shall the Company be liable for any consequential or incidental damages for breach of this or any other Warranty, expressed or implied whatsoever, even if the loss or damage is caused by the Company's negligence or fault. Some states do not allow the exclusion or limitation of incidental or consequential damages, so the above limitation or exclusion may not apply to you. This Warranty gives you specific legal rights, and you may also have other rights which vary from state to state.