



**MOTOROLA**

**ASTRO™** Digital XTS 3000™

Portable Radios  
Basic Service Manual

## Foreword

This manual covers all models of ASTRO™ Digital XTS 3000™ portable radios, unless otherwise specified. It includes all the information necessary to maintain peak product performance and maximum working-time using the pass/fail service approach. This basic level of service is typical of some local service centers, self-maintained customers, and some distributors.

Included in this manual are: radio specifications for the 800MHz frequency band; a general description of ASTRO Digital XTS 3000 models; recommended test equipment, service aids, and tools; radio alignment procedures; fundamental disassembly/reassembly procedures; and general maintenance recommendations.

For details on the operation of the radio, or board- or component-level troubleshooting, refer to the applicable manuals available separately. To help you with your selection, a list is provided in this manual, titled “Related Publications.”

### Safety Information

In 1991 the Institute of Electrical and Electronics Engineers (IEEE), and in 1992 the American National Standards Institute (ANSI), updated the 1982 ANSI Standard for safety levels with respect to human exposure to RF energy. Over 120 scientists, engineers, and physicians from universities, government health agencies, and industry, after reviewing the available body of research, developed this updated Standard. In March, 1993, the Federal Communications Commission (FCC) proposed the adoption of this updated Standard.

Motorola subscribes to the same safety standard for the use of its products. Proper operation of this radio will result in user exposure substantially below FCC recommended limits:

- **DO NOT** hold the radio with the antenna very close to, or touching, exposed parts of the body, especially the face, ears, or eyes, while transmitting. Hold the radio in a vertical position with the microphone **two to three inches** away from the lips.
- **DO NOT** hold the transmit switch (PTT) on when not actually desiring to transmit.
- **DO NOT** allow children to play with any radio equipment containing a transmitter.
- **DO NOT** operate this equipment near electrical blasting caps or in an explosive atmosphere. Under certain conditions, radios can interfere with blasting operations. When you are in the vicinity of construction work, look for, and observe, signs cautioning against radio transmissions. If radio transmission is prohibited, you must not transmit until out of the area. Furthermore, you must turn off your radio to prevent any accidental transmission.
- **DO NOT** replace or charge batteries in a hazardous atmosphere. Contact sparking may occur while installing or removing batteries and cause an explosion.
- Turn the radio off when removing or installing a battery.

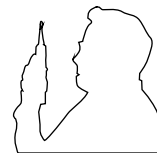

Anyone intending to use a radio in a hazardous area is advised to become familiar with the subject of intrinsic safety and with Section 70 of the National Fire Code, which is commonly referred to as Article 500 of the National Electric Code. Use of anything but factory supplied components may affect the approval and safety of the radio. Likewise, it is advised that servicing should be performed only by qualified personnel who adhere to the following Factory Mutual (FM) required warning:



Modification of FM approved intrinsically safe radios will negate Factory Mutual Research Corporation (FMRC) approval.

### WARNING

#### Airbag Warning Statement



VEHICLES EQUIPPED WITH AIR BAGS

### WARNING

An air bag inflates with great force. DO NOT place objects, including communication equipment, in the area over the air bag or in the air bag deployment area. If the communication equipment is improperly installed and the air bag inflates, this could cause serious injury.

- Installation of vehicle communication equipment should be performed by a professional installer/technician qualified in the requirements for such installations. An air bag's size, shape and deployment area can vary by vehicle make, model and front compartment configuration (for example, bench seat vs. bucket seats).
- Contact the vehicle manufacturer's corporate headquarters, if necessary, for specific air bag information for the vehicle make, model and front compartment configuration involved in your communication equipment installation.

### Manual Revisions

Changes which occur after this manual is printed are described in “FMRs.” These FMRs provide complete information on changes including pertinent parts listing data.

# Table of Contents

Foreword . . . . .	inside front cover
List of Figures . . . . .	ii
List of Tables . . . . .	ii
Related Publications . . . . .	ii
Portable Radio Model Numbering System . . . . .	iii
SPECIFICATIONS FOR 800MHz RADIOS . . . . .	iv
Glossary . . . . .	v
1 - Introduction . . . . .	1
General . . . . .	1
Notations Used in This Manual . . . . .	1
Radio Description . . . . .	2
FLASHport . . . . .	2
2 - Basic Maintenance . . . . .	3
Introduction to This Section . . . . .	3
Preventive Maintenance . . . . .	3
Handling Precautions . . . . .	4
3 - Recommended Test Equipment and Service Aids . . . . .	5
Recommended Test Equipment . . . . .	5
Service Aids . . . . .	5
Field Programming Equipment . . . . .	6
4 - Performance Checks . . . . .	7
Introduction to This Section . . . . .	7
Setup . . . . .	7
Test Mode . . . . .	7
5 - Radio Alignment Procedures . . . . .	13
Introduction to This Section . . . . .	13
General . . . . .	13
Reference Oscillator Alignment . . . . .	15
Transmit Power Alignment . . . . .	16
Transmit Deviation Balance (Compensation) Alignment . . . . .	17
Transmit Deviation Limit Alignment . . . . .	18
6 - Basic Removal/Installation Procedures . . . . .	21
Introduction to This Section . . . . .	21
Antenna . . . . .	21
Battery . . . . .	21
Belt Clip . . . . .	22
Universal Connector Cover . . . . .	23
Frequency Knob . . . . .	23
Volume Knob . . . . .	24

Ⓜ, Motorola, ASTRO, XTS 3000, Private-Line, and Digital Private-Line are trademarks of Motorola, Inc.

7 - Basic Theory of Operation . . . . .	27
General Overview . . . . .	27
Analog Mode of Operation . . . . .	27
ASTRO Mode of Operation . . . . .	28
RF Board Basic Theory of Operation . . . . .	28
Controller Board Basic Theory of Operation . . . . .	29
Vocoder Board Basic Theory of Operation . . . . .	29
8 - Radio-Level Troubleshooting . . . . .	31
Introduction to This Section . . . . .	31
Power-Up Error Codes . . . . .	31
Operational Error Codes . . . . .	32
Replacement Parts Ordering . . . . .	inside back cover

#### List of Figures

Figure 1. Radio Alignment Test Setup . . . . .	13
Figure 2. RSS Service Menu Layout . . . . .	14
Figure 3. Softpot Concept . . . . .	14
Figure 4. Reference Oscillator Alignment Screen . . . . .	15
Figure 5. Transmit Power Alignment Screen . . . . .	16
Figure 6. Transmit Deviation Balance (Compensation) Alignment Screen . . . . .	17
Figure 7. Transmit Deviation Limit Alignment Screen . . . . .	18
Figure 8. Partial Exploded View . . . . .	25

#### List of Tables

Table 1. ASTRO XTS 3000 Basic Features . . . . .	2
Table 2. Recommended Test Equipment . . . . .	5
Table 3. Service Aids . . . . .	6
Table 4. Initial Equipment Control Settings . . . . .	7
Table 5. Test Frequencies . . . . .	8
Table 6. Test Environments . . . . .	8
Table 7. Receiver Performance Checks . . . . .	10
Table 8. Transmitter Performance Checks . . . . .	11
Table 9. Reference Oscillator Alignment . . . . .	16
Table 10. Transmit Power Setting . . . . .	17
Table 11. Transmit Deviation Limit . . . . .	19
Table 12. Partial Exploded View Parts List . . . . .	26
Table 13. Local Oscillator and First IF Frequencies . . . . .	28
Table 14. Power-Up Error Code Displays . . . . .	31
Table 15. Operational Error Code Displays . . . . .	32
Table 16. Receiver Troubleshooting Chart . . . . .	32
Table 17. Transmitter Troubleshooting Chart . . . . .	33
Table 18. Encryption Troubleshooting Chart . . . . .	33

#### Related Publications

ASTRO Digital XTS 3000 Basic Model User's Guide . . . . .	68P81083C70
ASTRO Digital XTS 3000 Full-Featured Model User's Guide . . . . .	68P81083C75
ASTRO Digital XTS 3000 Detailed Service Manual . . . . .	68P81083C90

---

## Computer Software Copyrights

The Motorola products described in this manual may include copyrighted Motorola computer programs stored in semiconductor memories or other media. Laws in the United States and other countries preserve for Motorola certain exclusive rights for copyrighted computer programs, including the exclusive right to copy or reproduce in any form the copyrighted computer program. Accordingly, any copyrighted Motorola computer programs contained in the Motorola products described in this manual may not be copied or reproduced in any manner without the express written permission of Motorola. Furthermore, the purchase of Motorola products shall not be deemed to grant either directly or by implication, estoppel, or otherwise, any license under the copyrights, patents or patent applications of Motorola, except for the normal non-exclusive royalty free license to use that arises by operation of law in the sale of a product.

# Portable Radio Model Numbering System

**Typical Model Number:** H 0 9 U C F 9 P W 7 A N S P 0 1  
**Position:** 1 2 3 4 5 6 7 8 9 10 11 12 13 14 15 16

**Position 1 - Type of Unit**

H = Hand-Held Portable

**Positions 2 & 3 - Model Series**

09 = XTS 3000

**Position 4 - Frequency Band**

A = Less than 29.7MHz	P = 336 to 410MHz
B = 29.7 to 35.99MHz	Q = 403 to 437MHz
C = 36 to 41.99MHz	R = 438 to 482MHz
D = 42 to 50MHz	S = 470 to 520MHz
F = 66 to 80MHz	T = Product Specific
G = 74 to 90MHz	U = 806 to 870MHz
H = Product Specific	V = 825 to 870MHz
J = 136 to 162MHz	W = 896 to 941MHz
K = 146 to 178MHz	Y = 1.0 to 1.6GHz
L = 174 to 210MHz	Z = 1.5 to 2.0GHz
M = 190 to 235MHz	

*Values given represent range only; they are not absolute.*

**Position 5 - Power Level**

A = 0 to 0.7 Watts  
 B = 0.7 to 0.9 Watts  
 C = 1.0 to 3.9 Watts  
 D = 4.0 to 5.0 Watts  
 E = 5.1 to 6.0 Watts  
 F = 6.1 to 10 Watts

**Position 6 - Physical Packages**

A = RF Modem Operation  
 B = Receiver Only  
 C = Standard Control; No Display  
 D = Standard Control; With Display  
 E = Limited Keypad; No Display  
 F = Limited Keypad; With Display  
 G = Full Keypad; No Display  
 H = Full Keypad; With Display  
 J = Limited Controls; No Display  
 K = Limited Controls; Basic Display  
 L = Limited Controls; Limited Display  
 M = Rotary Controls; Standard Display  
 N = Enhanced Controls; Enhanced Display  
 P = Low Profile; No Display  
 Q = Low Profile; Basic Display  
 R = Low Profile; Basic Display, Full Keypad

**Position 7 - Channel Spacing**

1 = 5kHz      5 = 15kHz  
 2 = 6.25kHz    6 = 20/25kHz  
 3 = 10kHz      7 = 30kHz  
 4 = 12.5kHz    9 = Variable/Programmable

**Positions 13 - 16**

"SP" Model Suffix

**Position 12 - Unique Model Variations**

C = Cenelec  
 N = Standard Package

**Position 11 - Version**

Version Letter (Alpha) - Major Change

**Position 10 - Feature Level**

1 = Basic	6 = Standard Plus
2 = Limited Package	7 = Expanded Package
3 = Limited Plus	8 = Expanded Plus
4 = Intermediate	9 = Full Feature/ Programmable
5 = Standard Package	

**Position 9 - Primary System Type**

A = Conventional  
 B = Privacy Plus®  
 C = Clear SMARTNET™  
 D = Advanced Conventional Stat-Alert™  
 E = Enhanced Privacy Plus®  
 F = Nauganet 888 Series  
 G = Japan Specialized Mobile Radio (JSMR)  
 H = Multi-Channel Access (MCA)  
 J = CoveragePLUS™  
 K = MPT1327\* - Public  
 L = MPT1327\* - Private  
 M = Radiocom  
 N = Tone Signalling  
 P = Binary Signalling  
 Q = Phonetnet®  
 W = Programmable  
 X = Secure Conventional  
 Y = Secure SMARTNET™

\* MPT = Ministry of Posts and Telecommunications

**Position 8 - Primary Operation**

A = Conventional/Simplex  
 B = Conventional/Duplex  
 C = Trunked Twin Type  
 D = Dual Mode Trunked  
 E = Dual Mode Trunked/Duplex  
 F = Trunked Type I  
 G = Trunked Type II  
 H = FDMA\* Digital Dual Mode  
 J = TDMA\*\* Digital Dual Mode  
 K = Single Sideband  
 L = Global Positioning Satellite Capable  
 M = Amplitude Companded Sideband (ACSB)  
 P = Programmable

\* FDMA = Frequency Division Multiple Access

\*\* TDMA = Time Division Multiple Access

# SPECIFICATIONS FOR 800 MHz RADIOS

All specifications are per Electronic Industries Association (EIA) 316B unless otherwise noted

GENERAL	RECEIVER	TRANSMITTER
FCC Designation: AZ489FT5774	Frequency Range: 851–870MHz	RF Power: 3 Watts
Temperature Range: Operating: –30°C to +60°C Storage: –40°C to +85°C	Bandwidth: 19MHz	Frequency Range: 806–825MHz 851–870MHz
Power Supply: Nickel-Cadmium Battery (NiCd) or Nickel-Metal-Hydride Battery (NiMH)	Quieting Sensitivity (20dBQ): 0.5µV Max.	Frequency Stability (–30 to +60°C; 25°C ref.): ± .00015%
Battery Voltage: Nominal: 7.5 Volts Range: 6 to 9 Volts	Usable Sensitivity (12dB SINAD): 0.35µV Max.	Emission (Conducted and Radiated): –46dBw
Recommended Battery: Ultra-High Capacity NiMH: H335AC or Ultra-High Capacity NiCd FM: H223AX* or NiMH FM IS: Q393AB Optional FM (Factory Mutual) Battery: * FM Intrinsically Safe: Class I, II, III, Division 1, Groups D, F, and G	Intermodulation: –70dB	FM Hum and Noise (Companion Receiver): –40dB
Dimensions (H x W x D) Note: 2.44" = width at PTT; 2.34" = width at bottom; 1.83" = depth at speaker; 0.97" = depth at keypad Less Battery: 6.58" x 2.44" x 1.83"/6.58" x 2.34" x 0.97" (167.13mm x 61.90mm x 46.42mm/ 167.13mm x 59.49mm x 24.56mm) With Ultra-High Capacity NiMH Battery: 6.58" x 2.44" x 1.83"/6.58" x 2.34" x 1.65" (167.13mm x 61.90mm x 46.42mm/ 167.13mm x 59.49mm x 41.97mm) With Ultra-High Capacity NiCd Battery: 6.58" x 2.44" x 1.83"/6.58" x 2.34" x 1.65" (167.13mm x 61.90mm x 46.42mm/ 167.13mm x 59.49mm x 41.97mm) With NiMH FM IS Battery: 6.58" x 2.44" x 1.83"/6.58" x 2.34" x 1.65" (167.13mm x 61.90mm x 46.42mm/ 167.13mm x 59.49mm x 41.97mm)	Selectivity (25kHz Adjacent Channel): –70dB	Distortion: 3% Typical
	Spurious Rejection: –70dB	Modulation Limiting: (821-824MHz): ±5kHz ±4kHz
	Frequency Stability (–30+60°C; 25°C reference): ±.00015%	Emissions Designators: 20K0F1E, 16K0F3E, 15K0F2D, 15K0F1D, and 8K10F1E
	Rated Audio: 500mW	
	Distortion (At Rated Audio): 3% Typical	
	Channel Spacing: 25kHz	
Weight: (w/Helical Antenna) Less Battery: 14.10oz. (383gm) With Ultra-High Cap. NiMH: 23.45oz. (644gm) With Ultra-High Cap. NiCd: 25.19oz. (693gm) With NiMH FM IS: 23.45oz. (644gm)		

Specifications subject to change without notice

---

## GLOSSARY

A/D	Analog to Digital converter; converts an instantaneous dc voltage level to a corresponding digital value.
ABACUS IC	Custom integrated circuit providing a digital receiver IF backend.
ADSIC	ABACUS/DSP Support IC; custom integrated circuit providing peripheral functions for the DSP.
ALC	Automatic Level Control; a circuit in the transmit RF path that controls RF power amplifier output, provides leveling over frequency and voltage, and protects against high VSWR.
D/A	Digital to Analog converter; converts a digital value to a corresponding dc voltage value.
DTMF	Dual Tone Multi-Frequency
DPL	Digital Private-Line™
DSP	Digital Signal Processor; microcontroller specifically tailored for signal processing computations. In this case refers specifically to Motorola DSP56001.
Firmware	Software or a software/hardware combination of computer programs and data, with a fixed logic configuration stored in a read-only memory; information can not be altered or reprogrammed.
FGU	Frequency Generation Unit
FLASHport™	A Motorola term that describes the ability of a radio to change memory. Every FLASHport radio contains a FLASHport EEPROM memory chip that can be software written and rewritten to, again and again.
Host	Motorola HC11F1 microcontrol unit U204 (see MCU).
Host Port	Parallel memory mapped interface consisting of eight registers in the DSP56001.
IC	Integrated Circuit
IMBE	A sub-band, voice encoding algorithm used in ASTRO digital voice.
ISW	Inbound Signalling Word; data transmitted on the control channel from a subscriber unit to the central control unit.
LSH	Low Speed Handshake; 150 baud digital data sent to the radio during trunked operation while receiving audio.
MCU	MicroControl Unit
MDC	Motorola Digital Communications

MISO	Master In Slave Out; used by the slave device to send data to the master device.
MOSI	Master Out Slave In; used by the master device to send data to the slave device.
OMPAC	Over-Molded Pad-Array Carrier; a Motorola custom IC package, distinguished by the presence of solder balls on the bottom pads.
Open Architecture	A controller configuration that utilizes a microprocessor with extended ROM, RAM, and EEPROM.
OSW	Outbound Signalling Word; data transmitted on the control channel from the central controller to the subscriber unit.
PC Board	Printed Circuit board
PL	Private-Line <sup>®</sup> tone squelch; a continuous sub-audible tone that is transmitted along with the carrier.
PLL	Phase-Locked Loop; a circuit in which an oscillator is kept in phase with a reference, usually after passing through a frequency divider.
PTT	Push-To-Talk; the switch located on the left side of the radio which, when pressed, causes the radio to transmit.
Registers	Short-term data-storage circuits within the microcontrol unit or programmable logic IC.
Repeater	Remote transmit/receive facility that re-transmits received signals in order to improve communications coverage.
RESET	Reset line; an input to the microcontroller that restarts execution.
RF PA	Radio Frequency Power Amplifier
RSS	Radio Service Software
RPT/TA	RePeaTer/Talk-Around
RX DATA	Recovered digital data line.
Signal Qualifier Mode	An operating mode whereby the radio is muted but still continues to analyze receive data to determine RX signal type.
SCI IN	Serial Communication Interface INput line
SLIC	Support-Logic IC; a custom gate array used to provide I/O and memory expansion for the microcontroller.
Softpot	Software potentiometer; a computer-adjustable electronic attenuator.
Software	Computer programs, procedures, rules, documentation, and data pertaining to the operation of a system.
SPI	Serial Peripheral Interface; how the microcontroller communicates to modules and ICs through the CLOCK and DATA lines.



Squelch	Muting of audio circuits when received signal levels fall below a pre-determined value.
SRAM	Static-RAM chip used for volatile, program/data memory.
SSI	Synchronous Serial Interface on the DSP56001 consisting of six signals and used for an RX and TX modulated data interface to the ADSIC.
Standby Mode	An operating mode whereby the radio is muted but still continues to monitor data.
System Central Controllers	Main control unit of the trunked dispatch system; handles ISW and OSW messages to and from subscriber units (see ISW and OSW).
System Select	The act of selecting the desired operating system with the system-select switch (also, the name given to this switch).
TOT	Time-Out Timer; a timer that limits the length of a transmission.
TSOP	Thin Small-Outline Package
UART	Universal Asynchronous Receiver Transmitter.
μC	Microcontrol unit (see MCU).
VCO	Voltage-Controlled Oscillator; an oscillator whereby the frequency of oscillation can be varied by changing a control voltage.
VCOB IC	Voltage-Controlled Oscillator Buffer IC
Vocoder	VOIce enCODER; the DSP-based system for digitally processing the analog signals, includes the capabilities of performing voice compression algorithms or voice encoding.
VOCON	VOcoder/CONtroller board
VSELP	Vector Sum Excited Linear Predictive coding; a voice encoding technique used in ASTRO digital voice.
VSWR	Voltage Standing Wave Ratio



# Introduction



---

## General

This manual covers information needed for level one troubleshooting. Level one troubleshooting consists of radio programming, radio alignment, knobs replacement, and installation and removal of antenna, belt clip, battery, and universal connector cover. This will be the only level of service allowed for the service centers, self-maintained customers, and distributors for the first six months of the life of this product.

Included in this manual are radio specifications for the 800MHz frequency band, a general description of XTS 3000 models, recommended test equipment, service aids, radio alignment procedures, general maintenance recommendations, and procedures for basic assembly and disassembly.

---

## Notations Used in This Manual

Throughout the text in this publication, you will notice the use of warnings, cautions, and notes. These notations are used to emphasize that safety hazards exist, and care must be taken and observed.

*NOTE:* An operational procedure, practice, or condition, etc., which is essential to emphasize.



**Caution**

CAUTION indicates a potentially hazardous situation which, if not avoided, may result in equipment damage.



**WARNING**

WARNING indicates a potentially hazardous situation which, if not avoided, could result in death or injury.



DANGER indicates an imminently hazardous situation which, if not avoided, will result in death or injury.

---

## Radio Description

The ASTRO Digital XTS 3000 radios are among the most sophisticated two-way radios available. The radio is presently available in the 800MHz band; radios in the UHF and VHF bands will be available by the end of 1996.

One of the newest in a long line of quality Motorola products, the ASTRO Digital XTS 3000 radio provides improved voice quality across more coverage area. The digital process called "embedded signalling" intermixes system signalling information with digital voice, resulting in improved system reliability and the capability of supporting a multitude of advanced features. Such features add up to better, more cost-effective two-way radio communications.

ASTRO Digital XTS 3000 radios are available in two basic models. Table 1 provides a description of their basic features.

*Table 1 ASTRO XTS 3000 Basic Features*

<b>Feature</b>	<b>Basic Model</b>	<b>Full-Featured Model</b>
Display	None	LCD 4 lines/ 12 characters per line
Keypad	None	3 x 6 button
Channel Capability	48	255
Dialing from Prestored List	No	Yes
Programmable Softkeys	No	Yes

---

## FLASHport

The ASTRO Digital XTS 3000 radio utilizes Motorola's revolutionary FLASHport technology. FLASHport makes it possible to add software that drives the radio's capabilities both at the time of purchase and later on. Previously, changing a radio's features and capabilities meant significant modifications, or buying a new radio. But now, similar to how a computer can be loaded with different software, the radio's features and capabilities can be upgraded with FLASHport software.

# Basic Maintenance



---

## Introduction to This Section

This section of the manual describes preventive maintenance and handling precautions. Each of these topics provides information vital to the successful operation and maintenance of your radio.

---

## Preventive Maintenance

The ASTRO Digital XTS 3000 radios do not require a scheduled preventive maintenance program; however, periodic visual inspection and cleaning is recommended.

## Inspection

Check that the external surfaces of the radio are clean, and that all external controls and switches are functional. A detailed inspection of the interior electronic circuitry is not needed.

## Cleaning

The following procedures describe the recommended cleaning agents and the methods to be used when cleaning the external surfaces of the radio. External surfaces include the housing assembly and battery case. These surfaces should be cleaned whenever a periodic visual inspection reveals the presence of smudges, grease, and/or grime.

The only recommended agent for cleaning the external radio surfaces is a 0.5% solution of a mild dishwashing detergent, such as JOY®, in water.



### Caution

The effects of certain chemicals and their vapors can have harmful results on certain plastics. Aerosol sprays, tuner cleaners, and other chemicals should be avoided.

## Cleaning External Plastic Surfaces

(The detergent-water solution should be applied sparingly with a stiff, non-metallic, short-bristled brush to work all loose dirt away from the radio. A soft, absorbent, lintless cloth or tissue should be used to remove the solution and dry the radio. Make sure that no water remains entrapped near the connectors, cracks, or crevices.

---

## Handling Precautions

Complementary metal-oxide semiconductor (CMOS) devices, and other high-technology devices, are used in this family of radios. While the attributes of these devices are many, their characteristics make them susceptible to damage by electrostatic discharge (ESD) or high-voltage charges. Damage can be latent, resulting in failures occurring weeks or months later. Therefore, special precautions must be taken to prevent device damage during disassembly, troubleshooting, and repair. Handling precautions are mandatory for this radio, and are especially important in low-humidity conditions.

At this time, troubleshooting and repair of the radio will not be supported by the field or self-maintained customer. ***DO NOT attempt to disassemble the radio.***

# Recommended Test Equipment and Service Aids

# 3

## Recommended Test Equipment

The list of equipment contained in Table 2 includes all of the standard test equipment required for servicing two-way portable radios, as well as several unique items designed specifically for servicing this family of radios. The “Characteristics” column is included so that equivalent equipment may be substituted; however, when no information is provided in this column, the specific Motorola model listed is either a unique item or no substitution is recommended.

*Table 2 Recommended Test Equipment*

<b>Motorola Model Number</b>	<b>Description</b>	<b>Characteristics</b>	<b>Application</b>
R2670 or R2600	System Analyzer	This monitor will substitute for items with an asterisk (*).	Frequency/deviation meter and signal generator for wide-range troubleshooting and alignment.
R1049A*	Digital Multimeter		Recommended for ac/dc voltage and current measurements
R1150C*	Code Synthesizer		Injection of audio and digital signalling codes
S1053D* SKN6008A* SKN6001A*	AC Voltmeter Power Cable for Meter Test Leads for Meter	1mV to 300V, 10-Megohm input impedance	Audio voltage measurements
R1094A	Dual-Trace Oscilloscope	20MHz bandwidth 5mV to 5V/division	Waveform measurements
S1350C* ST1213B (VHF)* ST1223B (UHF)*	Wattmeter Plug-In Element RF Dummy Load	50-ohm, ±5% accuracy 10 watts, maximum 0-1000MHz, 300W	Transmitter power output measurements
R1065	Load Resistor	10-watt Broadband	For use with wattmeter
S1339A	RF Millivolt Meter	100µV to 3V RF	RF-level measurements
R1013A*	SINAD Meter		Receiver sensitivity measurements
S1347D or S1348D (programmable)	DC Power Supply	0-20Vdc, 0-5 Amps current limited	Bench supply for 7.5Vdc

## Service Aids

Refer to Table 3, “Service Aids,” for a listing and description of the service aids designed specifically for servicing this family of radios. These kits and/or parts are available from the Motorola Parts Division offices listed in the “Replacement Parts Ordering” section located on the inside back cover of this manual. While all of these items are available from Motorola, most are standard shop equipment items, and any equivalent item capable of the same performance may be substituted for the item listed.

*Table 3 Service Aids*

Motorola Part Number	Description	Application
RKN-4035D	RIB/Radio/Test Set Cable	Connects radio to RTX-4005B Test Box and RIB.
REX-4424	Battery Eliminator	Interconnects radio to power supply.
RLN-4460A, or RTX-4005B, or both RTX-4005A and RPX-4665A	Portable Test Set	Enables connection to the universal connector. Allows switching for radio testing.
Field Modification Kit RLN-1015A or RLN-4008B	Radio Interface Box	Enables communications between the radio and the computer's serial communications adapter.
01-80357A57	Wall-Mounted Power Supply	Used to supply power to the RIB (120 Vac).
01-80358A56	Wall-Mounted Power Supply	Used to supply power to the RIB (220 Vac).
30-80369B71 or 30-80369B72	Computer Interface Cable	Use B72 for the IBM PC AT. All other IBM models use B71. Connects the computer's serial communications adaptor to the RIB.
RVN-4100F	Radio Service Software	Software on 3-1/2 in. and 5-1/4 in. floppy disks.
58-80348B33	SMA to BNC Adaptor	Adapts radio's antenna port to BNC cabling of test equipment.

**Field  
Programming  
Equipment**

This family of radios can be aligned and programmed in the field. This requires specific equipment and special instructions. Refer to the applicable "Radio Service Software User's Guide" for complete field programming information.



# Performance Checks

# 4

---

## Introduction to This Section

This section covers performance checks used to verify the radio meets published specifications. The recommended test equipment listed in the previous section approaches the accuracy of the manufacturing equipment, with a few exceptions. Accuracy of the equipment must be maintained in compliance with the manufacturer's recommended calibration schedule.

---

## Setup

Supply voltage can be connected from the battery eliminator. The equipment required for alignment procedures is connected as shown in the "Radio Alignment Test Setup" diagram (page 13, Figure 1).

Initial equipment control settings should be as indicated in the following table, and should hold for all alignment procedures except as noted in Table 4.

*Table 4 Initial Equipment Control Settings*

System Analyzer	Test Set	Power Supply
<b>Monitor Mode:</b> Pwr Mon	<b>Spkr Set:</b> A	<b>Voltage:</b> 7.5Vdc
<b>RF Attn:</b> -70dB	<b>Spkr/Load:</b> Speaker	<b>DC On/Standby:</b> Standby
<b>AM, CW, FM:</b> FM	<b>PTT:</b> OFF (center)	<b>Volt Range:</b> 10Vdc
<b>O'scope Source:</b> Mod <b>O'scope Horiz:</b> 10mSec/Div <b>O'scope Vert:</b> 2.5kHz/Div <b>O'scope Trig:</b> Auto <b>Monitor Image:</b> Hi <b>Monitor BW:</b> Nar <b>Monitor Squelch:</b> Mid CW <b>Monitor Vol:</b> 1/4 CW		<b>Current:</b> 2.5Amps

---

## Test Mode

### RF Test Mode

When the ASTRO Digital XTS 3000 radio is operating in its normal environment, the radio's microcomputer controls the RF channel selection, transmitter key-up, and receiver muting. However, when the unit is on the bench for testing, alignment, or repair, it is removed from its normal environment. It cannot receive commands from its system and, therefore, the internal microcomputer will not key the transmitter nor unmute the receiver. This prevents the use of normal tune-up procedures. To solve this problem a special routine, called **TEST MODE** or "air test," has been incorporated in the radio.

To enter the test mode:

1. Turn the radio on and adjust the volume for a comfortable listening level. The volume level remains constant once in the test mode.
2. Within 10 seconds after the “Self Test” is complete, press **Side Button 3** five times in succession.
3. After “RF TEST” appears, press the **Top Programmable Button** (normally programmed as the emergency button) once. “1 CSQ” appears, indicating: test frequency 1, carrier squelch mode.
4. Each additional press of **Side Button 3** will advance to the next test channel. (Refer to Table 5.)
5. Pressing **Side Button 2** will scroll through and access test environments as shown in Table 6.

*NOTE:* Transmit into a load when keying a radio under test.

*Table 5 Test Frequencies*

Test Channel	800MHz
TX #1	806.0125
RX #1	851.0625
TX #2	815.0125
RX #2	860.0625
TX #3	824.9875
RX #3	869.9375
TX #4	851.0125
RX #4	851.0625
TX #5	860.0125
RX #5	860.0625
TX #6	869.9875
RX #6	869.9375
TX #7	None
RX #7	None















*Table 6 Test Environments*

Display	Description	Function
CSQ	Carrier Squelch	<b>RX:</b> unsquelch if carrier detected <b>TX:</b> mic audio
TPL	Tone Private-Line	<b>RX:</b> unsquelch if carrier and tone (192.8 Hz) detected <b>TX:</b> mic audio + tone (192.8 Hz)
AST	ASTRO	<b>RX:</b> none <b>TX:</b> 1200Hz tone *

\* All deviation values are based on deviation tuning of this mode.

## Control Top and Keypad Test Mode

To check the display, buttons, and switches, perform the following tests:

1. Turn the radio on and adjust the volume for a comfortable listening level. The volume level remains constant once in the test mode.
2. Within 10 seconds after the “Self Test” is complete, press **Side Button 3** five times in succession.
3. After “RF TEST” appears on the display, press **Side Button 1** once, “CH TEST” appears on the display.
4. Next, press and hold the **Top Programmable Button**; all segments on the display will light, and the LED on the control top will illuminate a red color.
5. Release the **Top Programmable Button**; “3/0” appears, which indicates that the **Top Programmable Button** is in the open condition.
6. Press the **Top Programmable Button** again; “3/1” appears, which indicates that the **Top Programmable Button** is in the closed condition.
7. Rotate the **Mode/Zone Selector Switch**; “4/0” through “4/15” appears, which indicates that the selector switch is in mode/zone position 1 through 15.
8. Rotate the **Two-Position (A/B) Switch**; “65/0” and “65/1” appear.
9. Rotate the **Three-Position Programmable Switch**; “67/0,” “67/1,” and “67/2” appear.
10. Rotate the **Volume Control**; “2/0” through “2/255” appear.
11. Press **Side Button 1**; “96/1” appears; release, “96/0” appears.
12. Press **Side Button 2**; “97/1” appears; release, “97/0” appears.
13. Press **Side Button 3**; “98/1” appears; release, “98/0” appears.
14. Press the **PTT Switch**; “1/1” appears; release, “1/0” appears.
15. Keypad Checks:
  - Press , “48/1” appears; release, “48/0” appears.
  - Press , “49/1” appears; release, “49/0” appears.
  - Press , “50/1” appears; release, “50/0” appears.
  - Press , “51/1” appears; release, “51/0” appears.
  - Press , “52/1” appears; release, “52/0” appears.
  - Press , “53/1” appears; release, “53/0” appears.
  - Press , “54/1” appears; release, “54/0” appears.
  - Press , “55/1” appears; release, “55/0” appears.
  - Press , “56/1” appears; release, “56/0” appears.
  - Press , “57/1” appears; release, “57/0” appears.
  - Press , “58/1” appears; release, “58/0” appears.
  - Press , “59/1” appears; release, “59/0” appears.
  - Press , “128/1” appears; release, “128/0” appears.
  - Press , “129/1” appears; release, “129/0” appears.
  - Press , “130/1” appears; release, “130/0” appears.

- Press the left-hand  $\ominus$  key on the top row of keys, “131/1” appears; release, “131/0” appears.
- Press the center  $\ominus$  key, “132/1” appears; release, “132/0” appears.
- Press the right-hand  $\ominus$  key, “133/1” appears; release, “133/0” appears.

Table 7 Receiver Performance Checks

Test Name	System Analyzer	Radio	Test Set	Comments
Reference Frequency	<b>Mode:</b> PWR MON 4th channel test frequency❖ <b>Monitor:</b> Frequency error. Input at RF In/Out	TEST MODE, 4 CSQ output at antenna	PTT to continuous (during the performance check)	Frequency error to be $\leq \pm 1.2\text{kHz}$
Rated Audio	<b>Mode:</b> GEN <b>Output level:</b> 1.0mV RF 4th channel test frequency❖ <b>Mod:</b> 1kHz tone at 3kHz deviation <b>Monitor:</b> DVM: ac Volts	TEST MODE, 4 CSQ	PTT to OFF (center); meter selector to Audio PA	Set volume control to 3.74Vrms
Distortion	As above, except to distortion	As above	As above	Distortion < 3.0%
Sensitivity (SINAD)	As above, except SINAD; lower the RF level for 12dB SINAD	As above	PTT to OFF (center)	RF input to be < 0.35 $\mu$ V
Noise Squelch Threshold (only radios with conventional system need to be tested)	RF level set to 1mV RF	As above	PTT to OFF (center); meter selection to Audio PA; spkr/load to speaker	Set volume control to 3.74Vrms
	As above, except change frequency to a conventional system. Raise RF level from zero until radio unsquelches.	Out of TEST MODE; select a conventional system	As above	Unsquelch to occur at < 0.25 $\mu$ V. Preferred SINAD = 8-10dB

❖ See Table 6

**Table 8 Transmitter Performance Checks**

Test Name	System Analyzer	Radio	Test Set	Comments
Reference Frequency	<b>Mode:</b> PWR MON 4th channel test frequency❖ <b>Monitor:</b> Frequency error. Input at RF In/Out	TEST MODE, 4 CSQ	PTT to continuous (during the performance check).	Frequency error to be $\leq \pm 1.2\text{kHz}$ .
Power RF	As above	As above, 4 CSQ	As above	Refer to Maintenance Specifications page in front of manual.
Voice Modulation	<b>Mode:</b> PWR MON 4th channel test frequency❖ atten to -70, input to RF In/Out. <b>Monitor:</b> DVM, ac Volts. Set 1kHz Mod Out level for 0.025Vrms at test set, 80mVrms at ac/dc test set jack	As above, 4 CSQ	As above, meter selector to mic	<b>Deviation: 800MHz:</b> $\geq 3.6\text{kHz}$ but $\leq 5.0\text{kHz}$
Voice Modulation (internal)	<b>Mode:</b> PWR MON 4th channel test frequency❖ atten to -70, input to RF In/Out	TEST MODE, 4 CSQ, output at antenna	Remove modulation input	Press PTT switch on radio. Say "four" loudly into the radio mic. <b>Measure deviation: 800MHz:</b> $\geq 3.8\text{kHz}$ but $\leq 5.0\text{kHz}$
PL Modulation (radios with conventional, clear mode, coded squelch operation only)	Change frequency to a conventional transmit frequency; BW to narrow	Conventional coded squelch personality (clear mode operation) 4 TPL	As above	<b>Deviation: 800MHz:</b> $\geq 500\text{Hz}$ but $\leq 1000\text{Hz}$
Talkaround Modulation (radios with conventional, clear mode, talk-around operation only)	Change frequency to conventional talk-around frequency. <b>Mode:</b> PWR MON deviation, attenuation to -70, input to RF In/Out. <b>Monitor:</b> DVM, ac volts Set 1kHz Mod Out level for 25mVrms at test set.	Conventional talkaround personality (clear mode operation) 1 CSQ	As above	<b>Deviation: 800MHz:</b> $\geq 3.8\text{kHz}$ but $\leq 5.0\text{kHz}$
Talkaround Modulation (radios with conventional, secure mode, talkaround operation only) (**)	Change frequency to conventional talk-around frequency. <b>Mode:</b> PWR MON deviation, attenuation to -70, input to RF In/Out. <b>Monitor:</b> DVM, ac volts <b>Mod:</b> 1kHz out level for 25mVrms at test set.	Conventional talkaround personality (secure mode operation). Load key into radio 1 sec.	As above	<b>Deviation: 800MHz:</b> $\geq 3.6\text{kHz}$ but $\leq 4.4\text{kHz}$

\* 800MHz radios only

\*\* The secure mode, talkaround modulation test is only required for trac mode radios which do not have clear mode talkaround capability.

❖ See Table 6

---

Notes

---

---

---

---

---

---

---

---

---

---

---

---

---

---

---

---

---

---

---

---

---

---

---

---

# Radio Alignment Procedures



## Introduction to This Section

This section describes both receiver and transmitter radio alignment procedures.

## General

An IBM personal computer (PC) and radio service software (RSS) are required to align the radio. Refer to the applicable RSS manual for installation and setup procedures for the software. To perform the alignment procedures, the radio must be connected to the PC, radio interface box (RIB), and a universal test set as shown in Figure 1.

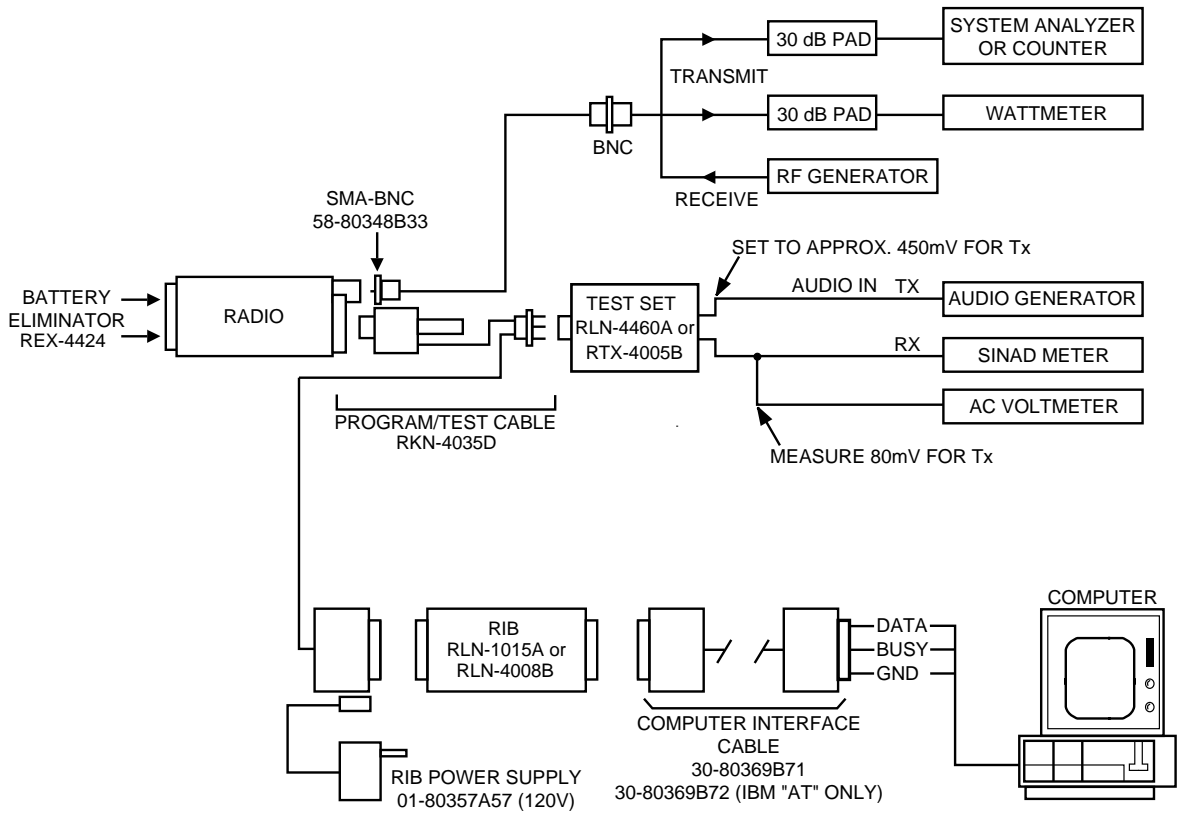
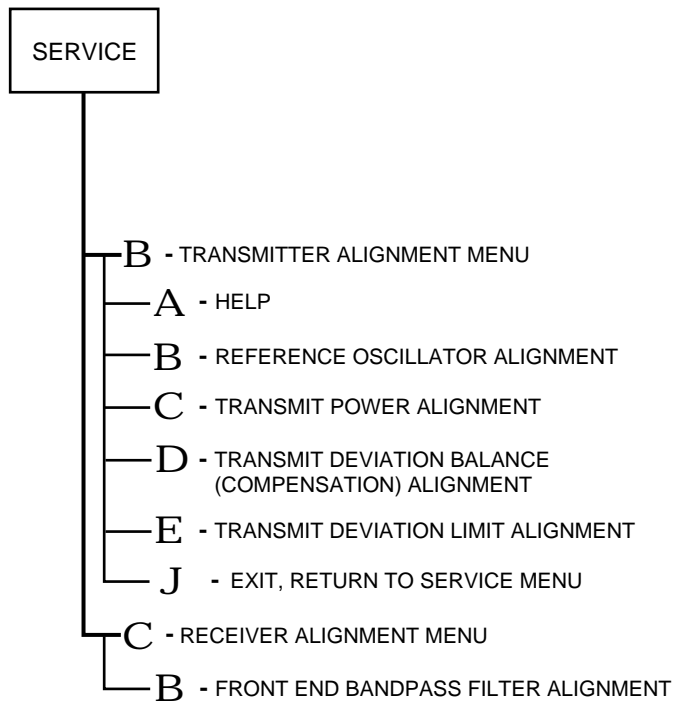

Figure 1 Radio Alignment Test Setup

All service and tuning procedures are performed from the SERVICE menu, which is selected by pressing **B** from the MAIN MENU. Figure 2 illustrates how the RSS alignment SERVICE screens are organized.



*Figure 2 RSS Service Menu Layout*

All SERVICE screens read and program the radio codeplug directly; you do NOT have to use the RSS GET/SAVE functions to use the SERVICE menus.



Do NOT switch radios in the middle of any SERVICE procedure. Always use the EXIT key to return to the MAIN menu screen before disconnecting the radio. Improper exits from the SERVICE screens may leave the radio in an improperly configured state and result in seriously degraded radio or system performance.

The SERVICE screens introduce the concept of the “softpot,” an analog **SOFT**ware-controlled **POT**entiometer used for adjusting all transceiver alignment controls.

Each SERVICE screen provides the capability to increase or decrease the ‘softpot’ value with the keyboard UP/DOWN arrow keys respectively. A graphical scale is displayed indicating the minimum, maximum, and proposed value of the softpot, as shown in Figure 3.

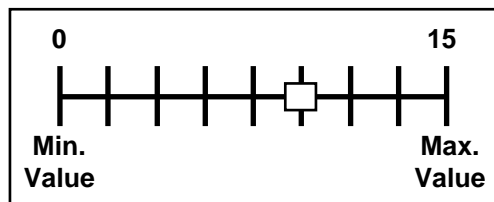

*Figure 3 Softpot Concept*



Adjusting the softpot value sends information to the radio to increase (or decrease) a dc voltage in the corresponding circuit. For example, pressing the UP arrow key at the Reference Oscillator screen instructs the radio's microcomputer to increase the voltage across a varactor in the reference oscillator, which increases the frequency.

In ALL cases, the softpot value is just a relative number corresponding to a digital-to-analog (D/A) generated voltage in the radio.

**Perform the following procedures in the sequence indicated.**

*NOTE:* Some of the following screens may vary depending upon the radio under test and the version of radio service software you are using. Refer to your radio service software user's guide.

## Reference Oscillator Alignment

Adjustment of the reference oscillator is critical for proper radio operation. Improper adjustment will result not only in poor operation, but also in a misaligned radio that will interfere with other users operating on adjacent channels. For this reason, the reference oscillator should be checked every time the radio is serviced. The frequency counter used for this procedure must have a stability of 0.1 ppm (or better).

1. From the SERVICE MENU, press **B** to select the TRANSMITTER ALIGNMENT MENU.
2. Press **B** again to select the REFERENCE OSCILLATOR alignment screen. See Figure 4.

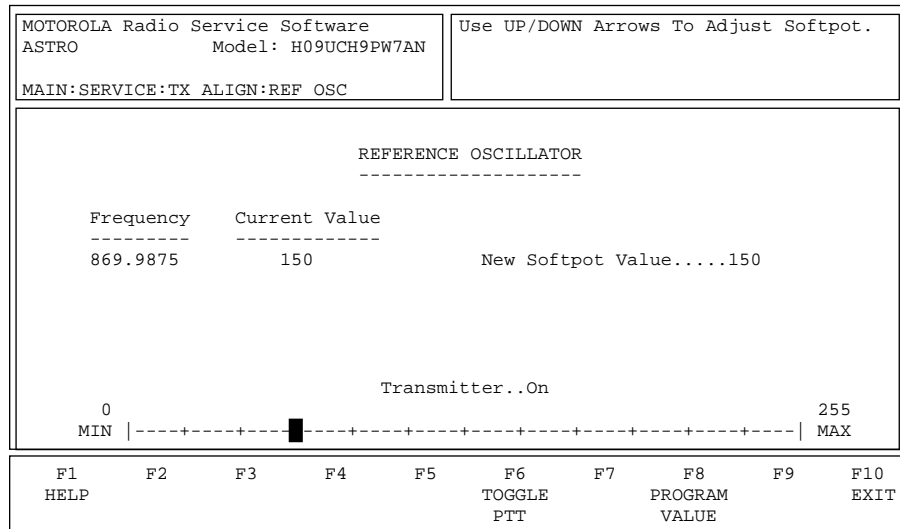

*Figure 4 Reference Oscillator Alignment Screen*

3. Press **P** (or **Z** or **[RETURN]**) to select a frequency field (starting with the highest frequency shown). Then, press **F** to key the radio. The screen will indicate that the radio is transmitting.

4. Measure the transmit frequency on your service monitor.
5. Use the  $\bar{E}/\bar{C}$  arrow keys to adjust the reference oscillator softpot value. See Table 9.

*Table 9 Reference Oscillator Alignment*

Band	Target
800 MHz	±150 Hz

6. Press **F** again to dekey the radio.
7. Press **H** to program the new softpot value.
8. Press **J** once to return to the TRANSMITTER ALIGNMENT MENU, or press **J** twice to return to the SERVICE MENU.

## Transmit Power Alignment

**NOTES:**

- All power measurements are to be made at the antenna port.
- The transmitter power setting keeps the radiated power at or below the level specified in the exclusionary clause for low power devices of IEEE Standard C95.1-1991.

1. From the SERVICE MENU, press **B** to select the TRANSMITTER ALIGNMENT MENU.
2. Press **C** to select the TRANSMIT POWER alignment screen. The screen will indicate the transmit frequencies to be used. See Figure 5.

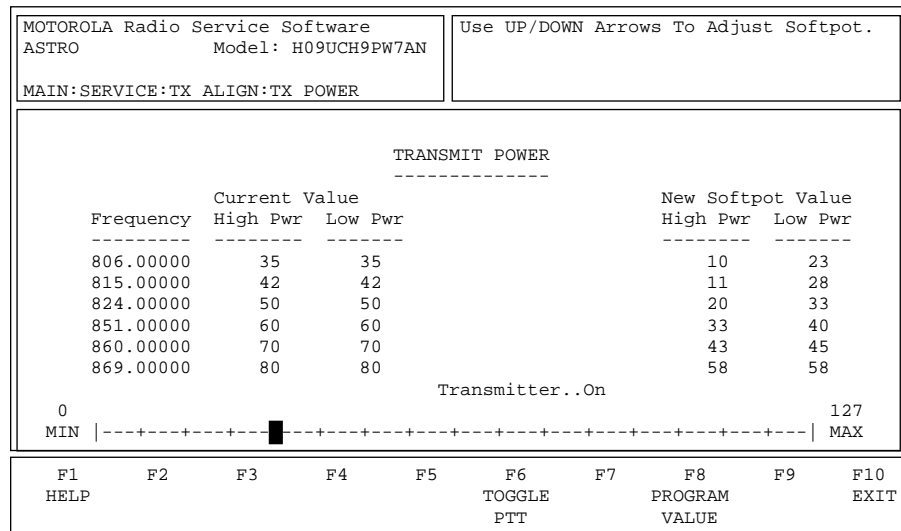

*Figure 5 Transmit Power Alignment Screen*

3. Press **P** (or **Z** or **[RETURN]**) to select a frequency field (starting with the highest frequency shown). Then, press **F** to key the radio. The screen will indicate that the radio is transmitting.
4. Use the  $\bar{E}/\bar{C}$  arrow keys to adjust the transmit power per the values shown in Table 10.

Table 10 Transmit Power Setting

800MHz Power Level	All Test Frequencies
3 Watts	3.2 - 3.4

5. Press **F** to dekey the radio.
6. Press **H** to program the value.
7. Repeat steps 3-6 for the remaining frequencies.
8. Press **J** once to return to the TRANSMITTER ALIGNMENT MENU, or press **J** twice to return to the SERVICE MENU.

Transmit  
Deviation  
Balance  
(Compensation)  
Alignment

Compensation alignment balances the modulation sensitivity of the VCO and reference modulation (synthesizer low-frequency port) lines. The compensation algorithm is critical to the operation of signalling schemes that have very-low-frequency components (for example, DPL) and could result in distorted waveforms if improperly adjusted.

1. From the SERVICE MENU, press **B** to select the TRANSMITTER ALIGNMENT MENU.
2. Press **D** to select the TRANSMIT DEVIATION BALANCE (COMPENSATION) alignment screen. The screen will indicate the transmit frequencies to be used. See Figure 6.

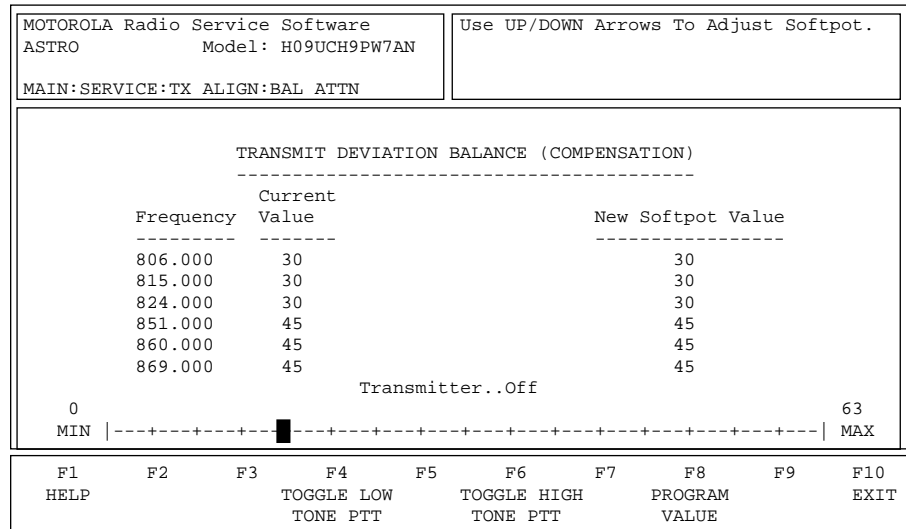

Figure 6 Transmit Deviation Balance (Compensation) Alignment Screen

3. Press **P** (or **Z** or **[RETURN]**) to select a frequency field (starting with the lowest frequency shown).
4. Press **D**. This will cause the radio to key and the radio's DSP IC to inject an 80Hz tone into the RF board.
5. Measure the deviation and record this value.
6. Press **D** to dekey the radio.

7. Press **F** . This will cause the radio's DSP IC to change the injection tone to 3kHz, 100mVrms. Use the **É/Ç** arrow keys to adjust the deviation to within  $\pm 2\%$  of the value recorded in step 5.
8. Repeat steps 4-7 until the 3kHz tone deviation is within  $\pm 2\%$  of the 80Hz tone deviation.
9. Press **F** again to dekey the radio.
10. Press **H** to program the new softpot value.
11. Repeat steps 3-10 for the remaining frequencies.
12. Press **J** once to return to the TRANSMITTER ALIGNMENT MENU, or press **J** twice to return to the SERVICE MENU.

## Transmit Deviation Limit Alignment

### **IMPORTANT NOTE:**

Put the radio in the RF test mode and scroll to the ASTRO test environment, indicated by "AST" on the display (refer to the "Performance Checks" section for details). All other deviation values are derived from the ASTRO test environment mode transmit deviation limit.

1. From the SERVICE MENU, press **B** to select the TRANSMITTER ALIGNMENT MENU.
2. Press **E** to select the TRANSMIT DEVIATION LIMIT alignment screen. The screen will indicate the transmit frequencies to be used. See Figure 7.

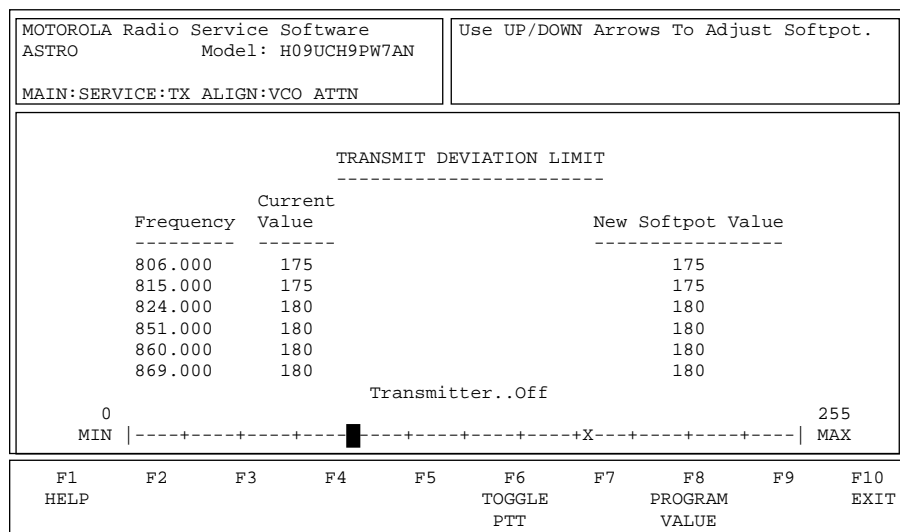

*Figure 7 Transmit Deviation Limit Alignment Screen*

3. Press **P** (or **Z** or **[RETURN]**) to select a frequency field (starting with the lowest frequency shown).
4. Press **F** to key the radio. Then use the **É/Ç** arrow keys to adjust for a deviation per the values shown in Table 11.

*Table 11 Transmit Deviation Limit*

Band	Deviation (Hz)
800 MHz	2785 - 2885

5. Press **F** again to dekey the radio.
6. Press **H** to program the softpot value.
7. Repeat steps 3-6 for the remaining frequencies.
8. Press **J** once to return to the TRANSMITTER ALIGNMENT MENU, or press **J** twice to return to the SERVICE MENU.



# Basic Removal/Installation Procedures

# 6

---

## Introduction to This Section

This section gives basic procedures for removing and installing the XTS 3000 radio's:

- Antenna,
- Battery,
- Belt Clip,
- Universal Connector Cover,
- Volume Knob, and
- Frequency Knob.

---

## Antenna

### Installing the Antenna

Screw the threaded end of the antenna into the antenna receptacle on the top of the radio. Rotate the antenna clockwise until it seats firmly against the bushing.

### Removing the Antenna

Rotate the antenna counterclockwise until its threaded end unscrews from the radio's antenna receptacle.

---

## Battery

**NOTE:** The battery is shipped uncharged, and must be charged before use.



**WARNING**

To avoid a possible explosion:

- DO NOT replace the battery in an area labeled "hazardous atmosphere."
- DO NOT discard batteries in a fire.



**Caution**

If your radio is programmed with volatile-key retention (consult your service technician), encryption keys will be retained for approximately 30 seconds after battery removal.

## Installing the Battery

1. Turn off the radio and hold it with the back of the radio facing upward
2. Insert the top edge of the battery into the area at the top of the radio between the radio's case and chassis. Make sure the three tabs on the radio chassis align with the three slots under the top edge of the battery.
3. Rotate the battery toward the radio, and squeeze the battery and radio together until the battery "clicks" in place.

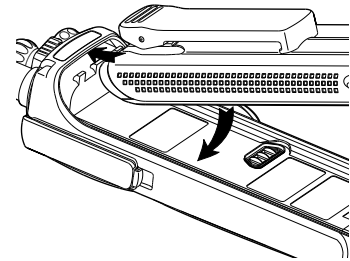

## Removing the Battery

1. Turn off the radio and hold it so that the release button on the bottom of the battery is facing upward.
2. Press downward on the release button so the battery disengages from the radio.
3. Remove the battery completely away from the radio

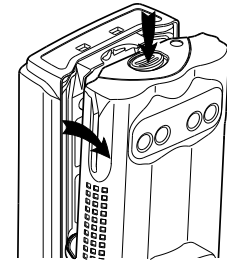

---

## Belt Clip

**NOTE:** The battery must be removed from the radio before the belt clip can be installed or removed.

## Installing the Belt Clip

1. Hold the battery in one hand so that the top of the battery faces upward, and the back of the battery faces you.
2. Holding the belt clip in the other hand with its top facing upward, align the slide assembly on the front of the belt clip with the slots on the back of the battery.
3. Slide the belt clip downward toward the bottom of the battery until the belt clip "clicks" in place.

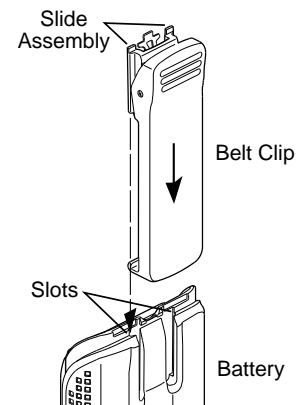

## Removing the Belt Clip

1. Hold the battery (with belt clip installed) in one hand so that the top of the battery faces upward, and the front (radio side) of the battery faces you.
2. At the top of the battery, press down on the belt clip's metal tab and slide the belt clip upward until it disengages from the battery.
3. Continue to slide the belt clip upward until it is free from the battery.

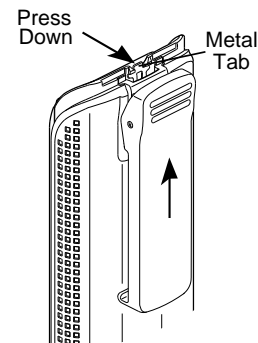



---

## Universal Connector Cover



When the universal connector is not in use, keep it covered with the universal connector cover.

### Caution

## Installing the Universal Connector Cover

1. Looking at the antenna side of the radio, insert the top (flat) hooked end of the cover into the slot on the top of the radio, above the universal connector. Press downward on the cover's top to seat it in the slot.
2. While holding the cover seated in the top slot, insert the cover's bottom (rounded) hooked end into the slot below the universal connector. Press firmly inward on the cover's bottom until it snaps in place.

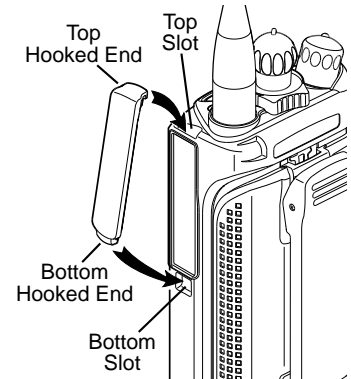

## Removing the Universal Connector Cover

1. Looking at the antenna side of the radio, insert a flat-bladed screwdriver into the area between the lower end of the universal connector cover and the slot below the universal connector.
2. Pry upward on the cover's lower end until it disengages from the radio.

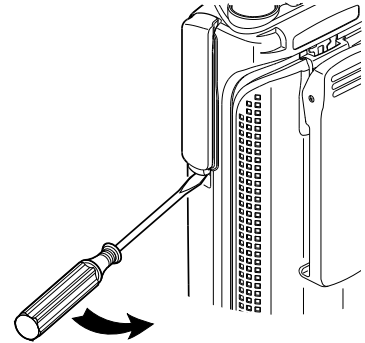

---

## Frequency Knob

### NOTES:

- Refer to Figure 8, the Partial Exploded View, and Table 12, the Partial Exploded View Parts List. Numbers in parentheses ( ) refer to item numbers in Figure 8 and Table 12.
- The battery (7) should be removed from the radio before installing or removing the frequency knob (1).

## Removing the Frequency Knob

1. Hold the radio in one hand so that the top of the radio faces upward, and the front of the radio faces you.
2. With the other hand, grasp the frequency knob (1) and pull it upward, while pushing it toward the back of the radio, until it is free from the frequency insert (3).
3. While pressing the insert's (3) two snap tabs away from the frequency control shaft so that the insert disengages from the shaft, use needle-nosed pliers to lift the insert up and off of the frequency control shaft.
4. Remove the secure lever (4) and the lightpipe (5).

## Installing the Frequency Knob

1. Hold the radio so that the top of the radio faces upward, and the front of the radio faces you.

2. Align the lightpipe (5) so that its straight tab is over the slot for the illuminated pointer. Push the tab down into the slot so that it is securely seated.
3. Place the secure lever (4) on the frequency control shaft, aligning it so that its pointer is at the front of the radio and its two inner slots line up with the two keys on the shaft. Slide the secure lever down to the bottom of the shaft.
4. If you are replacing the escutcheon (2), remove the backing paper from the escutcheon, align its alignment marker with the alignment notch (between numbers 4 and 5) on the insert, and adhere it to the insert.
5. Place the frequency insert (3) and escutcheon (2) on the frequency control shaft, aligning the insert's D-shaped hole with the D-shaped shaft. Press downward firmly on the insert until it "snaps" in place on the shaft.
6. Place the frequency knob (1) on the frequency insert (3), aligning its pointer with the number "1" on the escutcheon (2). Press firmly downward on the knob until it seats securely in place.

## Volume Knob

### *NOTES:*

- Refer to Figure 8, the Partial Exploded View, and Table 12, the Partial Exploded View Parts List. Numbers in parentheses ( ) refer to item numbers in Figure 8 and Table 12.
- The battery (7) should be removed from the radio before installing or removing the volume knob (8).

## Removing the Volume Knob

1. Hold the radio in one hand so that the top of the radio faces upward, and the front of the radio faces you.
2. With the other hand, grasp the volume knob (8) and pull it upward, while pushing it toward the back of the radio, until it is free from the volume insert (9).
3. While pressing the volume insert's (9) two snap tabs away from the volume control shaft so that the insert disengages from the shaft, use needle-nosed pliers to pull the insert up and off of the volume control shaft.
4. Using needle-nosed pliers or some other pointed instrument, remove the o-ring (21).

## Installing the Volume Knob

1. Place the o-ring (21) inside the volume insert (9), and press it downward until it seats securely at the bottom of the insert.
2. Hold the radio so that the top of the radio faces upward, and the front of the radio faces you.
3. Place the volume insert (9) on the volume control shaft, aligning its D-shaped hole with the D-shaped shaft. Press downward firmly on the insert until it "snaps" in place on the shaft.
4. Place the volume knob (8) on the volume insert (9), aligning the two lugs on the inside of the knob with the insert's two snap tabs. Press firmly downward on the knob until it seats securely in place.

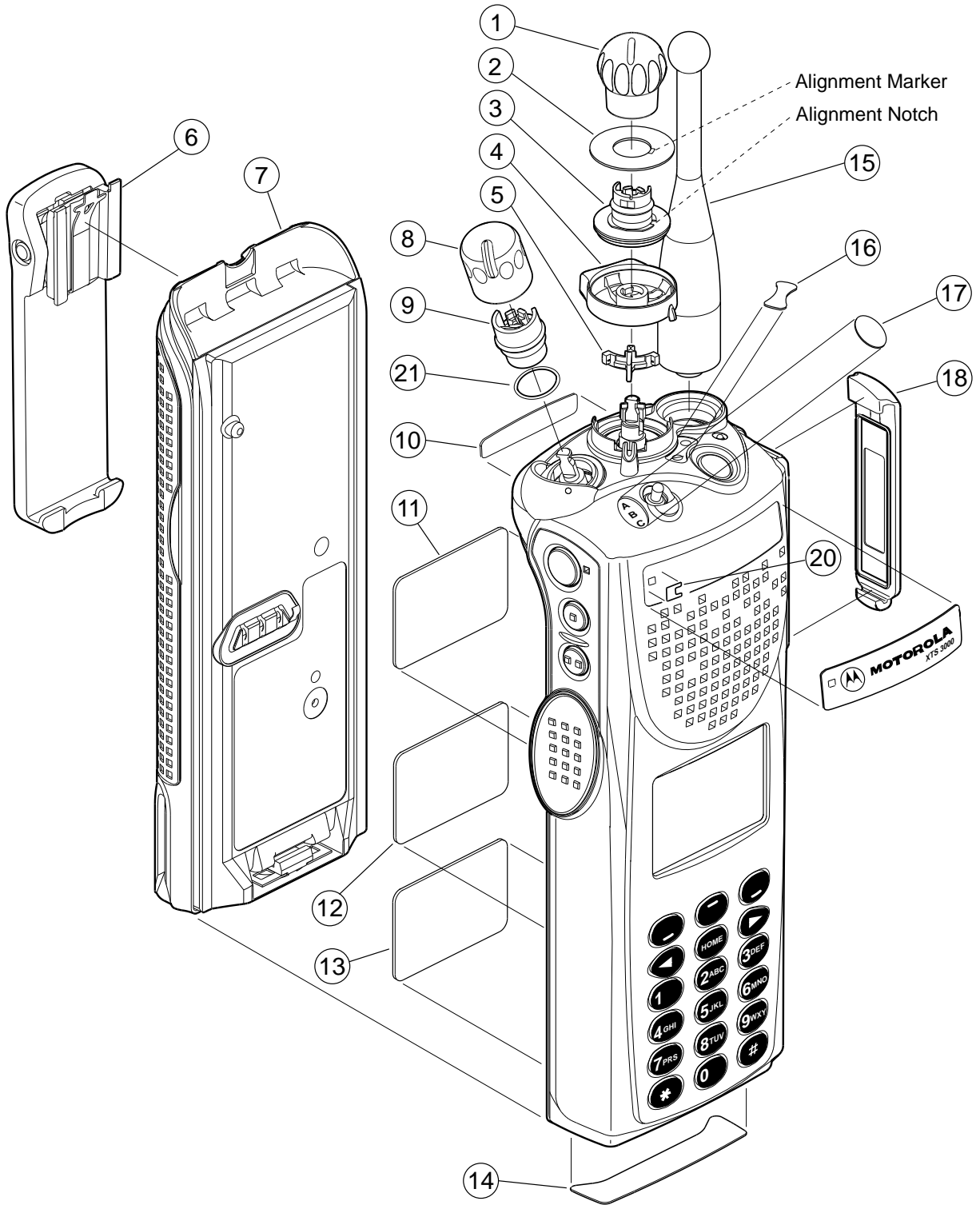

Figure 8 Partial Exploded View

*Table 12 Partial Exploded View Parts List*

ITEM NO.	MOTOROLA PART NO.	DESCRIPTION
1	3605370Z01	KNOB, Frequency
2	1305374Z01	ESCUTCHEON, Frequency
3	4305373Z01	INSERT RETAINER, Frequency Knob
4	4305375Z01	LEVER, Secure Frequency
5	6105376Z01	LIGHTPIPE INDICATOR/STOP, Frequency
6	NTN8266A	CLIP, Belt
7	NTN8298A	Battery, NiCd
8	3605371Z01	KNOB, Volume
9	4305372Z01	INSERT RETAINER, Volume Knob
10	3305574Z01	LABEL, Motorola, Back
11	-----	LABEL, Flashport
12	-----	LABEL, Radio Serial Number
13	-----	LABEL, Approval Agency
14	3305630Z02	LABEL, Bottom
15	NAF5037A or NAF5039A or NAF5042A	ANTENNA, 800MHz Whip (806-870 MHz) ANTENNA, 800MHz Dipole (806-870 MHz) ANTENNA, 800MHz Stubby Quarterwave (806-870 MHz)
16	-----	ESCUTCHEON, Concentric Switch (optional)
17	-----	ESCUTCHEON, Toggle (optional)
18	1505579Z01	COVER, Dust, Universal Connector
19	3305573Z01	LABEL, Motorola, Front
20	3505586Z01	Gortex
21	3205379W01	O-Ring

# Basic Theory of Operation

# 7

---

## General Overview

The ASTRO Digital XTS 3000 radio is a wideband, synthesized, fixed-tuned radio available in the 800MHz band. All ASTRO Digital XTS 3000 radios are capable of both analog operation and ASTRO mode (digital) operation in 12.5kHz or 25kHz bandwidths.

The ASTRO Digital XTS 3000 radio includes the following major assemblies:

- Controller Board - contains the microcontrol unit (MCU) and its associated memory and memory management integrated circuit (IC), the audio power amplifier, and a switching regulator.
- RF Board - contains all transmit, receive, and frequency generation circuitry including the digital receiver back-end IC and the reference oscillator.
- Vocoder Board - contains the digital signal processor (DSP) and its support IC and associated memories.
- Controls/Universal Flex - contains volume/on/off switch, frequency selector switch, push-to-talk (PTT) switch, monitor button, several function-selectable switches, universal connector, speaker, and microphone.
- Display (Full-Featured Model Only) - a four-line, 12-character liquid crystal display (LCD).
- Keypad (Full-Featured Model Only) - a 3 x 6 keypad.

---

## Analog Mode of Operation

When the radio is *receiving*, the signal comes from the antenna connector to the RF board, passes through the RX/TX switch and the receiver front end. The signal is then filtered, amplified, and mixed with the first local-oscillator signal generated by the voltage-controlled oscillator (VCO).

The resulting intermediate frequency (IF) signal is fed to the IF circuitry, where it is again filtered and amplified. This amplified signal is passed to the digital back-end IC, where it is mixed with the second local oscillator to create the second IF at 450kHz. It is then converted to a digital bit stream and mixed a third time to produce a baseband signal. This signal is passed to the vocoder board through a current-driven differential output.

On the vocoder board, the digital- signal-processor-support IC digitally filters and discriminates the signal, and passes it to the digital-signal processor (DSP). The DSP decodes the information in the signal and identifies the appropriate destination for it. For a voice signal, the DSP will route the digital voice data to the DSP-support IC for conversion to an analog signal. The DSP-support IC will then present the signal to the audio power amplifier, which drives the speaker. For signalling information, the DSP will decode the message and pass it to the microcontrol unit.

When the radio is *transmitting*, microphone audio is passed from the audio power amplifier (PA) to the DSP-support IC, where the signal is digitized. The DSP-support IC passes digital data to the DSP, where pre-emphasis and low-pass (splatter) filtering are done. The DSP returns this signal to the DSP-support IC, where it is reconverted into an analog signal and scaled for application to the voltage-controlled oscillator as a modulation signal.

Transmitted signalling information is accepted by the DSP from the microcontrol unit, coded appropriately, and passed to the DSP-support IC, which handles it the same as a voice signal. Modulation information is passed to the synthesizer along the modulation line. A modulated carrier is provided to the RF PA, which transmits the signal under dynamic power control.

## ASTRO Mode of Operation

In the ASTRO mode (digital mode) of operation, the transmitted or received signal is limited to a discrete set of deviation levels, instead of continuously varying. The receiver handles an ASTRO-mode signal identically to an analog-mode signal up to the point where the DSP decodes the received data. In the ASTRO receive mode, the DSP uses a specifically defined algorithm to recover information.

In the ASTRO transmit mode, microphone audio is processed identically to an analog mode with the exception of the algorithm the DSP uses to encode the information. This algorithm will result in deviation levels that are limited to discrete levels.

## RF Board Basic Theory of Operation

The receiver front end consists of a preselector, an RF amplifier, a second preselector, and a mixer. On the 800MHz receiver front end, both preselectors are varactor-tuned, two-pole, fixed-tuned filters. The RF amplifier is a dual-gate, gallium-arsenide based IC. The mixer is a double-balanced, active mixer coupled by transformers. Injection is provided by the VCO through an injection filter. See Table 13 for local oscillator (LO) and first IF information.

*Table 13 Local Oscillator and First IF Frequencies*

	800MHz
LO Frequency Range	732.65-796.65MHz
First IF Frequency	73.35MHz

The frequency generation function is performed by three ICs and associated circuitry. The reference oscillator provides a frequency standard to the synthesizer/prescaler IC, which controls the VCO IC. The VCO IC actually generates the first LO and transmit-injection signals and buffers them to the required power level. The synthesizer/prescaler circuit module incorporates frequency-division and comparison circuitry to keep the VCO signals stable. The synthesizer/prescaler IC is controlled by the microcontrol unit through a serial bus. Most of the synthesizer circuitry is enclosed in rigid metal cans on the RF board to reduce microphonic effects.

The receiver back end consists of a two-pole crystal filter, an IF amplifier, a second two-pole crystal filter, and the digital back-end IC. The two-pole filters are wide enough to accommodate 5kHz modulation. Final IF filtering is done digitally in the DSP-support IC.

The digital back-end IC consists of an amplifier, the second mixer, an IF analog-to-digital converter, a baseband down-converter, and a 2.4MHz synthesis circuit to provide a clock to the DSP-support IC on the vocoder board. The second LO is generated by discrete components external to the IC. The output of the digital back-end IC is a digital bit stream that is current driven on a differential pair for a reduction in noise generation.

The transmitter consists of an RF PA IC that gets an injection signal from the VCO. Transmit power is controlled by two custom ICs that monitor the output of a directional coupler and adjust PA control voltages correspondingly. The signal passes through a RX/TX switch that uses PIN diodes to automatically provide an appropriate interface to transmit or receive signals. Antenna selection is done mechanically in the control top.

---

## Controller Board Basic Theory of Operation

The controller board contains the radio's microcontrol unit with its memory and support circuits, voltage regulators, audio, and power control circuits. Connected to the controller board are the display board, RF board, vocoder board, keypad board, controls/universal flex, and (optional) encryption module.

The microcontrol unit controls receive/transmit frequencies, power levels, display, and other radio functions, using either direct logic control or serial communications paths to the devices. The microcontrol unit executes a stored program located in the FLASH ROM. Data is transferred to and from memory by the microcontrol unit data bus. The memory location from which data is read, or to which data is written, is selected by the address lines.

The support-logic IC acts as an extension of the microcontrol unit by providing logic functions such as lower address latch, reset, memory address decoding, and additional control lines for the radio. The microcontrol unit controls the crystal-pull circuit to adjust the crystal oscillator's frequency on the microcontrol unit, so that the E-clock's harmonics do not cause interference with the radio's receive channel.

The regulator and power-control circuits include an unswitched +5V discrete circuit and the regulator/power-control IC. Switched +5V is used for all circuits on the controller board except the audio PA, which is sourced from 7.5V. The regulator automatically provides 5V when the radio is turned on. The regulator's power-down mode is controlled by the microcontrol unit, which senses the position of the on/off switch.

---

## Vocoder Board Basic Theory of Operation

The vocoder board contains the digital-signal processor (DSP), its memory devices, and the DSP-support IC.

The DSP performs signalling and voice encoding and decoding as well as audio filtering and volume control. This IC performs Private-Line®/Digital Private Line™ (PL/DPL) encode and alert-tone generation. The IC transmits pre-emphasis on analog signals and applies a low-pass (splatter) filter to all transmitted signals. It requires a 33MHz crystal to function. An 8kHz interrupt signal generated by the DSP-support IC is

also required for functionality. It is programmed using parallel programming from the microcontrol unit and the DSP-support IC.

The DSP-support IC performs analog-to-digital and digital-to-analog conversions on audio signals. It contains attenuators for volume, squelch, deviation, and compensation, and it executes receiver filtering and discrimination. The IC requires a 2.4MHz clock to function (generated by the digital back-end IC) and is programmed by the microcontrol unit SPI bus.



# Radio-Level Troubleshooting

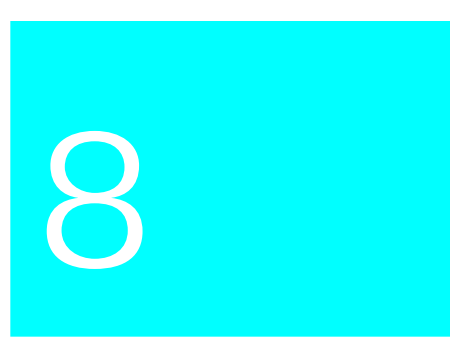

## Introduction to This Section

This section of the manual contains troubleshooting charts and error codes that will help you to isolate a problem. Level one troubleshooting will support only radio alignment, programming, battery replacement, and knob replacement. If the radio needs further troubleshooting, it must be sent to the depot.

Board- and component-level and service information can be found in the “ASTRO Digital XTS 3000 Portable Radios Detailed Service Manual,” Motorola publication number 68P81083C90.

## Power-Up Error Codes

When the radio is turned on (power-up), the radio performs cursory tests to determine if its basic electronics and software are in working order. Problems detected during these tests are presented as error codes on the radio’s display. The presence of an error should prompt the user that a problem exists and that a service technician should be contacted.

Self-test errors are classified as either fatal or non-fatal. Fatal errors will inhibit user operation; non-fatal errors will not. Use Table 14 to aid in understanding particular power-up error code displays.

*Table 14 Power-Up Error Code Displays*

Error Code	Description	Corrective Action
01/02	External EEPROM Checksum Non-Fatal Error	Reprogram codeplug.
01/81	ROM Checksum Failure	Send radio to depot.
01/82	External EEPROM Checksum Failure	Reprogram the codeplug.
01/84	SLIC Initialization Failure	Turn the radio off, then on.
01/88	RAM Failure - Note: not a checksum failure	Turn the radio off, then on.
01/90	General Hardware Failure	Turn the radio off, then on.
01/92	Internal EEPROM Checksum Failure	Reprogram the codeplug.
02/10	DSP support IC checksum Non-Fatal Error	Turn the radio off, then on.
02/81	DSP ROM Checksum Failure	Send radio to depot.
02/88	DSP RAM Failure - Note: not a checksum failure	Turn the radio off, then on.
02/90	General DSP Hardware Failure (DSP startup message not received correctly)	Turn the radio off, then on.
02/A0	ADSIC Checksum Failure - Non-Fatal Error	Turn the radio off, then on.
09/10	Secure Hardware Failure	Send radio to depot.
09/90	Secure Hardware Failure	Send radio to depot.

**Note:** If the corrective action does not fix the failure, send the radio to the depot.

## Operational Error Codes

During radio operation, the radio performs dynamic tests to determine if the radio is working properly. Problems detected during these tests are presented as error codes on the radio's display. The presence of an error code should prompt a user that a problem exists and that a service technician should be contacted. Use Table 15 to aid in understanding particular operational error codes.

*Table 15 Operational Error Code Displays*

Error Code	Description	Corrective Action
FAIL 001	Synthesizer Out-of-Lock	a. Reprogram codeplug b. Send radio to depot
FAIL 002	Selected Mode/Zone Codeplug Checksum Error	Reprogram codeplug

*Table 16 Receiver Troubleshooting Chart*

Symptom	Possible Cause	Correction or Test (Measurements Taken at Room Temperature)
Radio Dead; Display Does Not Light Up	1. Dead Battery	Replace with charged battery.
	2. Blown Fuse	Send radio to depot.
	3. On/Off Switch	
	4. Regulators	
Radio Dead; Display Lights Up	1. Controller Board	Send radio to depot.
	2. RF Board	
No Receiver Audio or Receiver Does Not Unmute	Programming	a. Does the transmitted signal match the receiver configuration (PL, DPL, etc.)? b. With the monitor function enabled, can the radio be unmuted?
Audio Distorted or Not Loud Enough	Synthesizer Not On Frequency	Check synthesizer frequency by measuring the transmitter frequency; if off by more than $\pm 250\text{Hz}$ , realign.
RF Sensitivity Poor	1. Synthesizer Not On Frequency	Check synthesizer frequency by measuring the transmitter frequency; if off by more than $\leq \pm 600\text{Hz}$ , realign.
	2. Antenna Switch	Send radio to depot.
	3. Receiver Front-End Tuning (VHF/ UHF only)	Check RF front-end tuning for optimum sensitivity using the RSS.
Radio Will Not Turn Off	Controller Board	Send radio to depot.

*Table 17 Transmitter Troubleshooting Chart*

Symptom	Possible Cause	Correction or Test (Measurements Taken at Room Temperature)
No RF Power Out	1. TX Power Level or Frequency	Check TX power level and frequency programming (from RSS).
	2. No PTT From Control Top	Send radio to depot.
	3. No Injection To Power Amplifier	
No Modulation; Distorted Modulation	1. Programming	Check deviation and compensation settings using the RSS.
	2. Controller Board	Send radio to depot.
Bad Microphone Sensitivity	1. Check Deviation and Compensation	Realign if necessary.
	2. Microphone	Send radio to depot.
No/Low Signalling (PL, DPL, MDC)	1. Programming	Check Programming
	2. Controller Board	Send radio to depot.
Can't Set Compensation	RF Board	Send radio to depot.

*Table 18 Encryption Troubleshooting Chart*

Symptom	Possible Cause	Corrective Action
No "KEYLOAD" on Radio Display When Keyloading Cable is Attached to the Radio Side Connector	1. Defective Keyload Cable	Send radio to depot.
	2. Defective Radio	
Keyloader Displays "FAIL."	1. Wrong Keyloader	Make Sure the Keyloader is a "T---CX" or "T---DX" Keyloader.
	2. Bad Keyloader	Try Another Keyloader
	3. Defective Radio	Send radio to depot.

**Note:** Keyloaders "T---AX" and "T---BX" must be upgraded to "T---CX" and "T---DX" in order to keyload an XTS 3000 radio.

---

Notes

---

---

---

---

---

---

---

---

---

---

---

---

---

---

---

---

---

---

---

---

---

---

---

---

---

---

# BASIC SERVICE MANUAL QUESTIONNAIRE

We believe that reports from users provide valuable information for producing quality manuals. By taking a few moments to answer the following questions as they relate to this specific manual, you can take an active role in the continuing effort to ensure that our manuals contain the most accurate and complete information of benefit to you. Thank you for your cooperation.

In reference to Manual Number: **68P81083C85-0**

## ASTRO™ Digital XTS 3000™ Portable Radios

1. Please check all the appropriate boxes:

	Complete	Incomplete	Correct	Incorrect	Clear	Confusing	Size Adequate	Size Too Small	Not Covered in This Manual
Performance Checks									
Radio Alignment Procedures									
Disassembly/Reassembly Procedures									
Basic Theory of Operation									

2. How would you rate the overall organization of this manual?

excellent
very good
good
fair
poor

3. Did this service manual provide you with the information necessary to service and maintain the specific equipment?

very much so
generally yes
to some extent
no

4. How do you rate this particular service manual?

excellent
very good
good
fair
poor

5. We would appreciate any corrections or recommendations for improving this manual. Please include the specific page number(s) of the diagram or procedure in question.

- a. Performance Checks: (Page No. \_\_\_\_\_)
- b. Radio Alignment Procedures: (Page No. \_\_\_\_\_)
- c. Disassembly/Reassembly Procedures: (Page No. \_\_\_\_\_)
- d. Basic Theory of Operation: (Page No. \_\_\_\_\_)

CUT ALONG DOTTED LINE

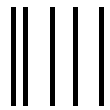

NO POSTAGE  
NECESSARY  
IF MAILED  
IN THE  
UNITED STATES

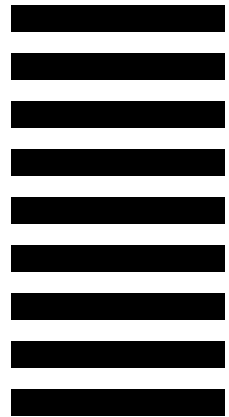

**BUSINESS REPLY MAIL**  
FIRST CLASS MAIL PERMIT NO 9040 FT. LAUDERDALE, FL

POSTAGE WILL BE PAID BY ADDRESSEE



**MOTOROLA**

Attention: Technical Communications  
8000 W. Sunrise Boulevard  
Ft. Lauderdale, FL 33322



.....  
FOLD

.....  
FOLD

Please specify the page number along with any corrections or recommendations for improvement.

6. General comments/suggestions:

(Continued)

Name: \_\_\_\_\_

Company: \_\_\_\_\_

Customer       COSC       MSS       FTR       Other

Address: \_\_\_\_\_

City/State/Zip: \_\_\_\_\_

Phone Number (Please include Area Code): \_\_\_\_\_

PLEASE USE TAPE TO SEAL  
POSTAL REGULATIONS PROHIBIT USE OF STAPLES

# REPLACEMENT PARTS ORDERING

## ORDERING INFORMATION

When ordering replacement parts or equipment information, the complete identification number should be included. This applies to all components, kits, and chassis. If the component part number is not known, the order should include the number of the chassis or kit of which it is a part, and sufficient description of the desired component to identify it.

Crystal and channel element orders should specify the crystal or channel element type number,

crystal and carrier frequency, and the model number in which the part is used.

Orders for active filters, Vibrasender and Vibrasponder resonant reeds should specify type number and frequency, should identify the owner/operator of the communications system in which these items are to be used, and should include any serial numbers stamped on the components being replaced.

## MAIL ORDERS

### Send written orders to the following addresses:

Replacement Parts/  
Test Equipment/Manuals  
Crystal Service Items:

Motorola Inc.  
Americas Parts Division  
Attention: Order Processing  
1313 E. Algonquin Road  
Schaumburg, IL 60196

Federal Government Orders:

Motorola Inc.  
Americas Parts Division  
Attention: Order Processing  
7230 Parkway Drive  
Landover, MD 21076

International Orders:

Motorola Inc.  
Americas Parts Division  
Attention: International Order Processing  
1313 E. Algonquin Road  
Schaumburg, IL 60196

## TELEPHONE ORDERS

Americas Parts Division:

Call: 1-800-422-4210  
1-800-826-1913 (For Federal Government Orders)  
1-708-538-8023 (International Orders)

Field Assist Service Training

(FAST VHS Video Tapes):  
Call: 708-576-8012

## TELEX/FAX ORDERS

Americas Parts Division:

FAX: 708-538-8198 (Domestic)  
708-576-3023 (International)

Parts ID: 708-538-8194

Telex: 280127 (Domestic)  
403305 (International)

Federal Government Orders:

FAX: 410-712-4991

## PARTS CUSTOMER SERVICE

Americas Parts Division:

Call: 1-800-422-4210

Parts Identification:

Call: 708-538-0021

## PRODUCT CUSTOMER SERVICE

Customer Response Center  
(Sales and Service Assistance):

Call: 1-800-247-2346

FAX: 1-800-232-9272



68P81083C85-O

Motorola  
8000 West Sunrise Boulevard  
Fort Lauderdale, Florida 33322