

User's Manual  
TR3-C202-A0-1

**TAKAYA**

---

---

# Introduction

Thank you for purchasing a TR3-C202-A0-1 RFID READER/WRITER.

Be sure to read this manual before using the product.

After reading it, store the manual in a convenient place for future reference.

---

---

# Regulations and Standards

## FCC

This product is conform to the FCC standards.  
FCC Rules (Federal Communications Commission)  
This product complies with Part 15 Subpart C of the FCC Rules.  
FCC ID : MK4TR3-C202-A0-1

### FCC NOTICE

This device complies with part 15 of the FCC Rules. Operation is subject to the following two conditions:

- (1) This device may not cause harmful interference.
- (2) This device must accept any interference received, including interference that may cause undesired operation.

### FCC WARNING

Changes or modifications not expressly approved by the party responsible for compliance could void the user's authority to operate the equipment.

The following sentence has to be displayed on the outside of the device in which the transmitter module is installed : “Contains FCC ID: MK4TR3-C202-A0-1”

## Japan Radio Law

Equipment using high frequencies: Inductive Reading/Writing Communications Equipment  
Conforming standards: Inductive Reading/Writing Communications Equipment;  
Standard: ARIB STD-T82

## Tags

This product can communicate the standard tags of ISO/IEC15693 and ISO/IEC18000-3(Mode1).

Supports	Manufacturer
Tag-it HF-I	Texas Instruments
my-d	Infineon Technologies
I·CODE SLI	NXP Semiconductors
MB89R118	FUJITSU Japan

## RoHS is support

Restriction of Hazardous Substances

## Waste

Dispose of the Products as industrial waste.



---

---

# Safety Precautions

The following symbols are used in this manual to indicate precautions that must be observed to ensure safe use of this product. The precautions provided here contain important safety information. Be sure to observe these precautions.

The following signal words are used in this manual.

 <b>WARNING</b>	Failure to comply with a <b>WARNING</b> may result in serious injury or death.
 <b>CAUTION</b>	Failure to comply with a <b>CAUTION</b> may result in injury to the operator, or damage to the items involved.

## **WARNING**

**Be sure to observe the following precautions to ensure safe use of the Products.**

Decomposition of this product and cable, repair, remodeling, please strictly prohibited. There is the possibility of fire or electric shock injuries.

This product is using the RFID reader writer radio equipment. Therefore, depending on where the applications you use may affect medical equipment. To minimize the impact of medical equipment for use, please observe the following countermeasure. The Japan Automatic Identification Systems Association (JAISA) guidelines are as follows: RFID antennas from implanted cardiac pacemakers or other medical devices please 22cm apart. We recommend that you paste "RFID sticker" at equipment.



← RFID Sticker

## **CAUTION**

**Be sure to observe the following precautions to ensure safe use of the Products.**

Installation and storage environment

1. Do not use the Products in sunlight.
2. Do not use the Products in environment of spray of water, oil or chemicals.
3. Do not use the Products in environments with flammable, explosive, or corrosive gasses.
4. Do not use the Products in environment of hot humid.
5. Do not use the Products in environment of vibration or shock.
6. Do not use the Products in environment of condensation.
7. Do not use the Products in environment of around the metal is covered.
8. Do not use the Products in environment of high temperature.
9. Do not use the Products in environment that has a device that generates magnetic field and shock voltage.
10. Do not use the Products in unstable place.
11. If there is failure, discontinue use immediately, please contact us or the distributor.

Installation

1. Turn off the power before installation or removing.
2. The following effects may not work correctly.
  - Near 13.56MHz radio device
  - Near speakers , Inverter, motor and Plasma Display
3. The communication range may vary due to environment and conditions.

---

---

# Contents

<b>1</b>	<b>Product Overview .....</b>	<b>1</b>
1.1	Features .....	1
<b>2</b>	<b>Names of Parts and Functions .....</b>	<b>2</b>
2.1	TR3-C202-A0-1.....	2
2.2	Antenna.....	3
2.2.1	TR3-A202.....	3
2.2.2	TR3-A302.....	4
2.2.3	TR3-A401.....	4
<b>3</b>	<b>Installation and connection .....</b>	<b>5</b>
3.1	Installation into a host device.....	5
3.1.1	Installation from the Front.....	5
3.1.2	Installation from the Back .....	5
3.2	Antenna installation into a host device.....	6
3.2.1	Screw holes.....	6
3.2.2	Guide .....	6
3.3	Connection .....	7
3.3.1	Attaching the Cable and Antenna.....	7
3.3.2	Direct connection to the Host Device Interface.....	7
3.3.3	Using the interface board to connect to the Host Device Interface .....	8
<b>4</b>	<b>Specifications .....</b>	<b>9</b>
4.1	TR3-C202-A0-1.....	9
4.2	Antenna.....	14
4.2.1	TR3-A202.....	14
4.2.2	TR3-A302.....	15
4.2.3	TR3-A401.....	16
4.3	Cable.....	17
4.3.1	TR3-AC-1A-*** .....	17
4.3.2	TR3-AC-2A-*** .....	17
<b>5</b>	<b>Maintenance .....</b>	<b>18</b>
	<b>Revision History .....</b>	<b>19</b>

# 1 Product Overview

## 1.1 Features

This product uses the 13.56MHz frequency. This product is the electromagnetic induction type non-contact IC can read and write RFID tag data.

This Product is designed to be embedded and integrated within OEM devices and finished products such as label printers, cashless payment terminals or any other device that can benefit from integrated RFID capabilities.

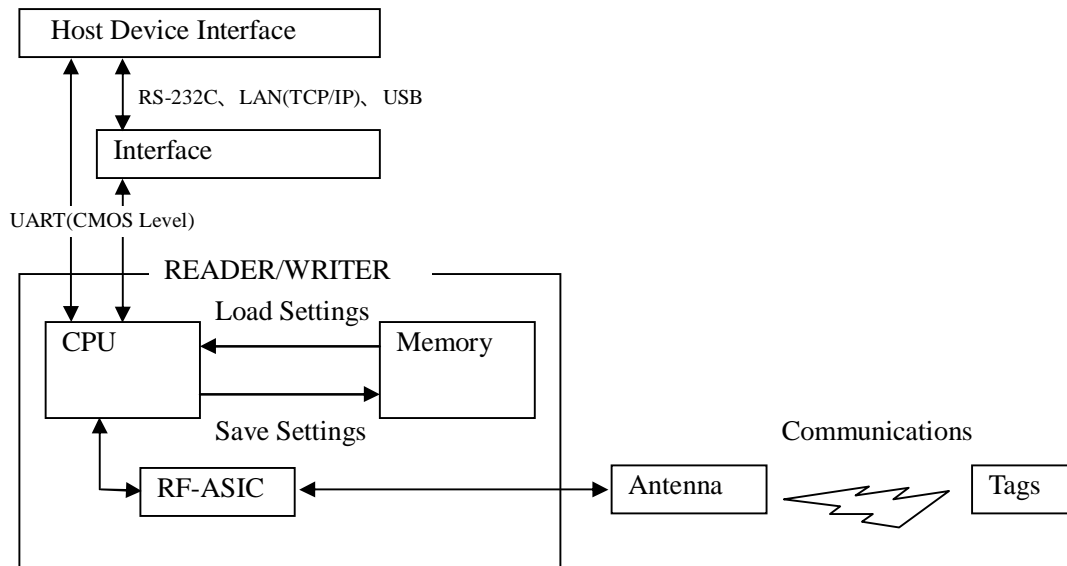

Conform to international standards  
ISO/IEC15693 and ISO/IEC18000-3(Mode1) is supports.

### Rich Products

- Various interface RS-232C, USB, TCP/IP.
- Antennas of various sizes

### Software

- TR3-series common communication protocol
- Software Development Kit

### Useful

- Continuous inventory mode  
UID of the tag automatically sends Host Device.
- RDLoop mode  
UID or User Data of the tag automatically sends Host Device.

For more information please refer to the TR3-PROTOCOL manual.

### Environmentally

EU RoHS(2002/95/EC) Support

# 2 Names of Parts and Functions

## 2.1 TR3-C202-A0-1

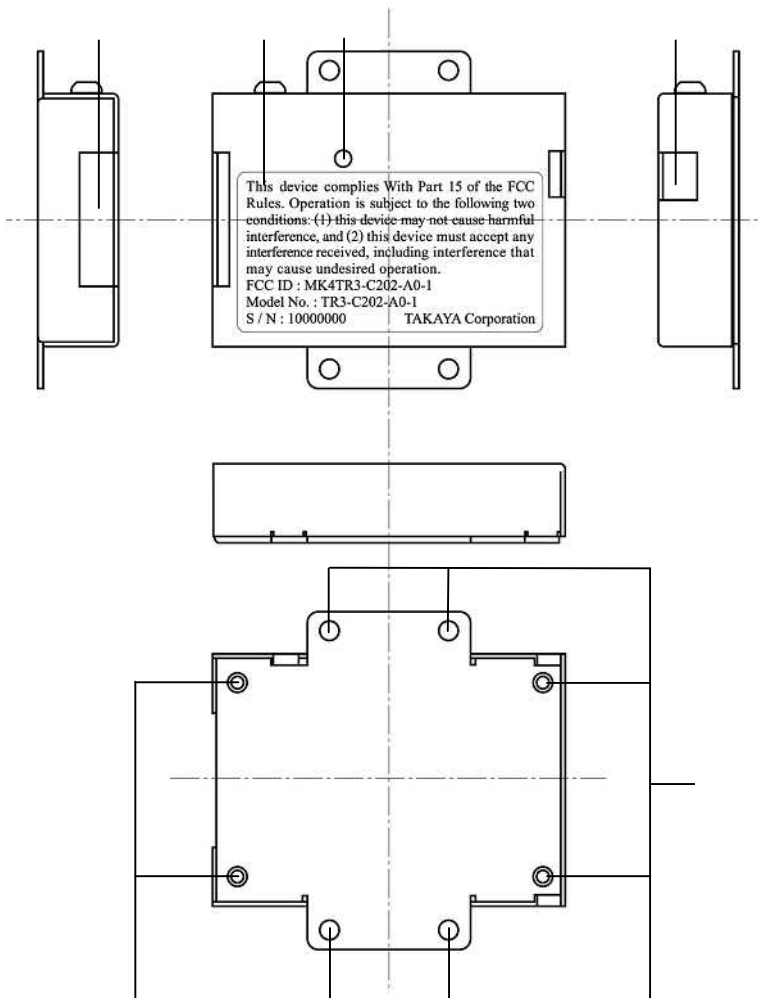

No	Name	Description
	CN1	This connector is for connection to the host.
	FCC ID stickers	Production numbers, will be 8-digit serial number. <div style="border: 1px solid black; padding: 5px; margin: 5px 0;"> <p>This device complies With Part 15 of the FCC Rules. Operation is subject to the following two conditions: (1) this device may not cause harmful interference, and (2) this device must accept any interference received, including interference that may cause undesired operation.                      FCC ID : MK4TR3-C202-A0-1                      Model No. : TR3-C202-A0-1                      S / N : 10000000 TAKAYA Corporation</p> </div> <p style="margin-left: 40px;">Model Name</p> <p style="margin-left: 40px;">Serial number : * * * * * (F)</p>
	LED1	Displays the status of this product.
	CN2	Connect the antenna cable.
	Screw holes	M3 holes

## 2.2 Antenna

### 2.2.1 TR3-A202

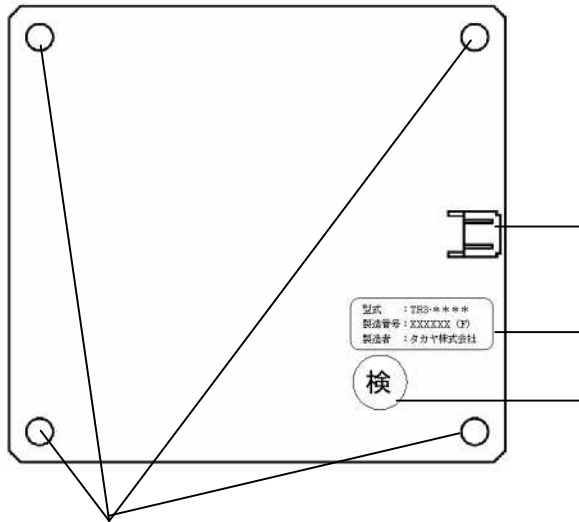

No	Name	Description
	CN1	Connect the antenna cable.
	Nameplate	Production numbers, will be 8-digit serial number. <div style="border: 1px solid black; padding: 5px; display: inline-block;">           型式 : TR3-****      Model Name            製造番号 : XXXXXX (F)      Serial number : * * * * * (F)            製造者 : タカヤ株式会社         </div>
	Inspection mark	
	Screw holes	M3 holes



2.2.2 TR3-A302

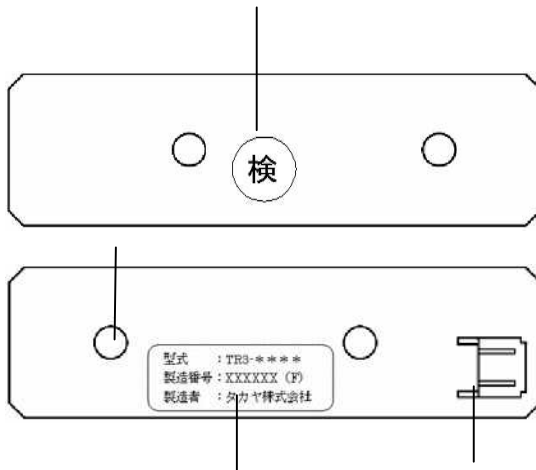

No	Name	Description
	Inspection mark	
	Screw holes	M3 holes
	Nameplate	Production numbers, will be 8-digit serial number. <div style="border: 1px solid black; padding: 5px; margin: 5px 0;">           型式 : TR3-****      Model Name            製造番号 : XXXXXX (F)      Serial number : * * * * * * * * (F)            製造者 : タカヤ株式会社         </div>
	CN1	Connect the antenna cable.

2.2.3 TR3-A401

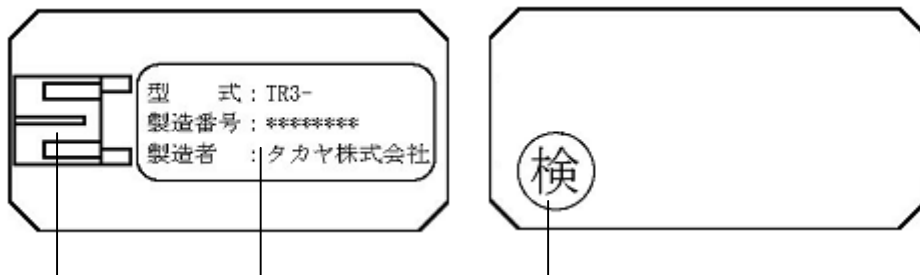

No	Name	Description
	CN1	Connect the antenna cable.
	Nameplate	Production numbers, will be 8-digit serial number. <div style="border: 1px solid black; padding: 5px; margin: 5px 0;">           型式 : TR3-****      Model Name            製造番号 : XXXXXX (F)      Serial number : * * * * * * * * (F)            製造者 : タカヤ株式会社         </div>
	Inspection mark	

## 3 Installation and connection

### 3.1 Installation into a host device

#### 3.1.1 Installation from the Front

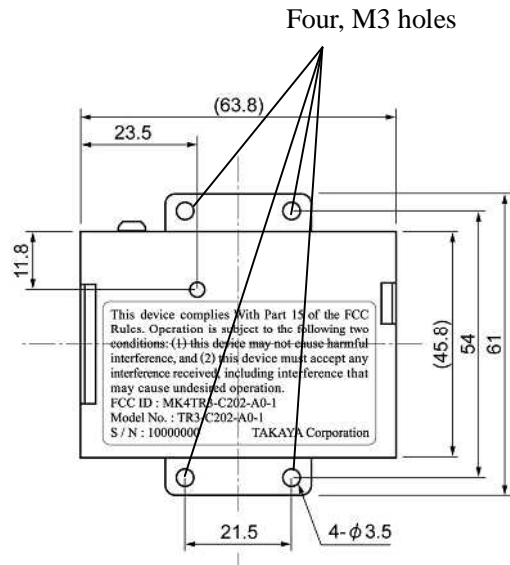
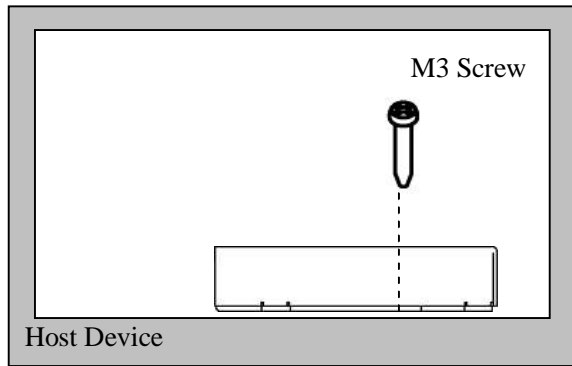

#### 3.1.2 Installation from the Back

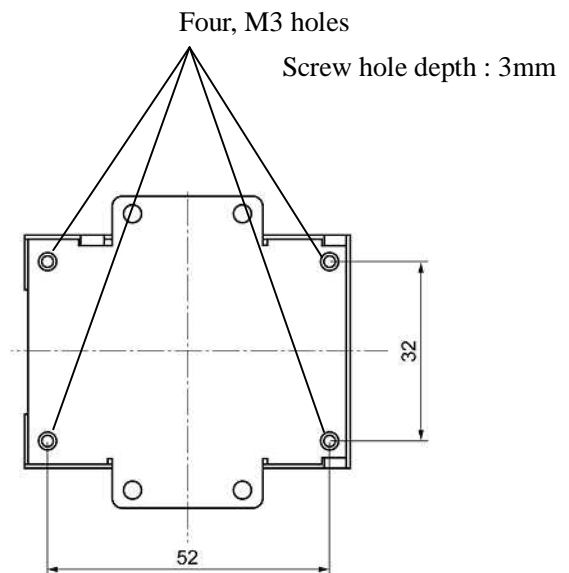
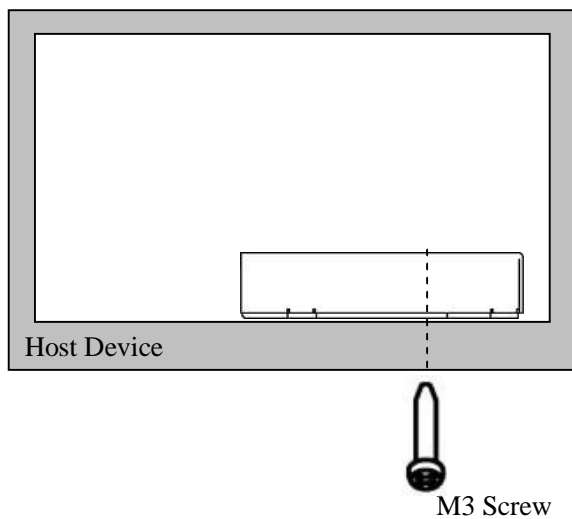

## 3.2 Antenna installation into a host device

### 3.2.1 Screw holes

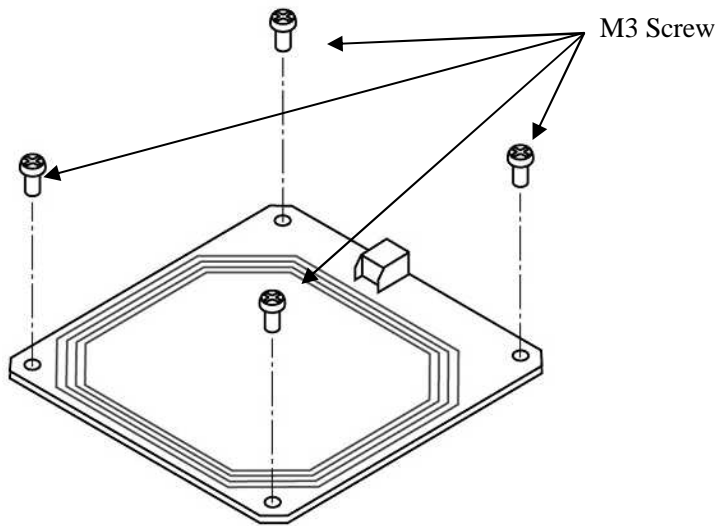

### 3.2.2 Guide

TR3-A401 is recommended that you set up a guide on fixed-like the figure below.

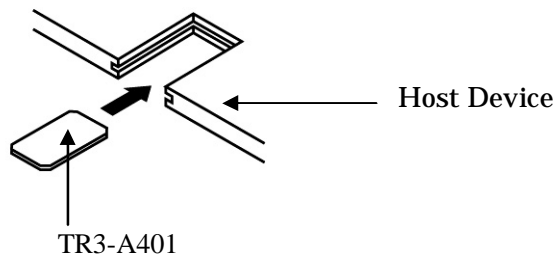

### 3.3 Connection

This product will connect with the antenna and antenna cables.

This product connects with Host Device that direct connection or connect using our interface.

#### 3.3.1 Attaching the Cable and Antenna

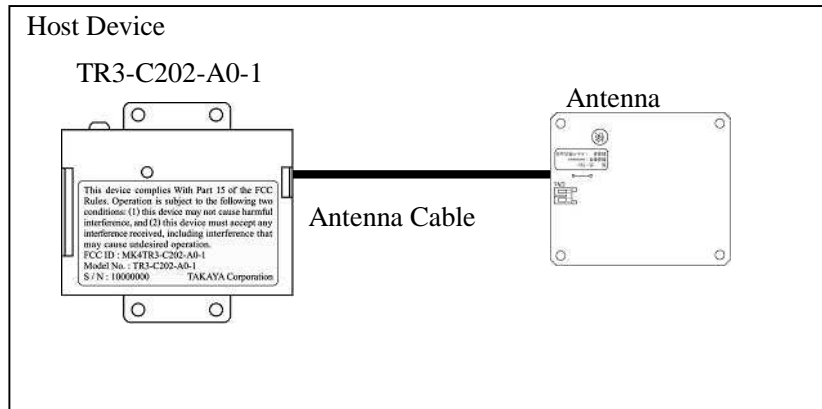

#### 3.3.2 Direct connection to the Host Device Interface

Please prepare to the interface harness.

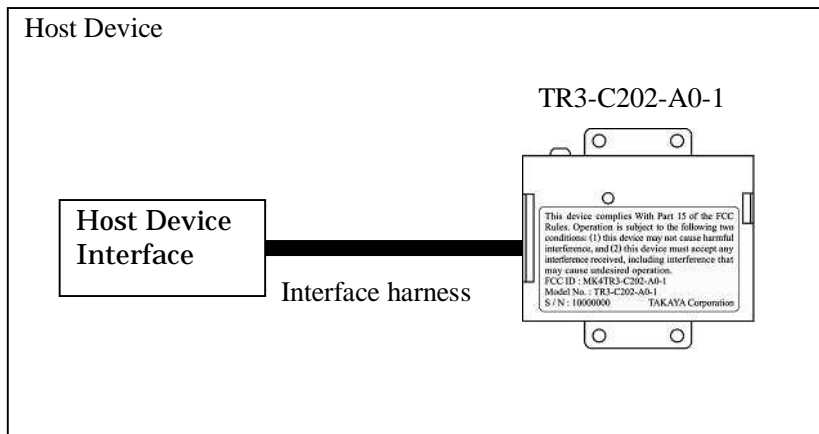

3.3.3 Using the interface board to connect to the Host Device Interface  
Interface board, please contact us.

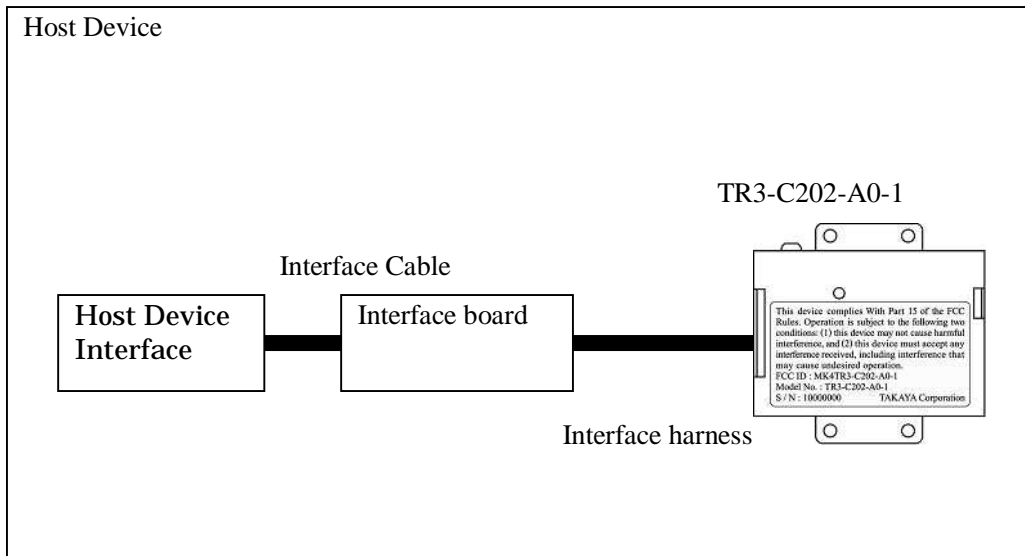

# 4 Specifications

## 4.1 TR3-C202-A0-1

### Specifications

Specifications	Item	Parameter												
Applicable Standards	Japan Radio Law	ARIB STD-T82												
	FCC	FCC Part 15 Subpart C FCC ID : MK4TR3-C202-A0-1												
	RoHS	EU RoHS(2002/95/EC) Supports												
Radio Frequency	Carrier frequency	13.56MHz ±50ppm(Ta=25 ) or less												
	Transmit power or power range	10 ~ 100mW ± 20%(Ta=25 , VCC=5.0V)												
	Standards	ISO/IEC 15693、 ISO/IEC18000-3(Model1)												
	Tags	Tag-it HF-I, my-d, I• CODE SLI, MB89R118( 1)												
	Data rate	<table border="1"> <thead> <tr> <th></th> <th>Speed</th> <th>Data rate</th> </tr> </thead> <tbody> <tr> <td>Reader/Writer Tag</td> <td>1/4</td> <td>26.48kbps</td> </tr> <tr> <td></td> <td>1/256</td> <td>1.65kbps</td> </tr> <tr> <td>Tag Reader/Writer</td> <td colspan="2">26.69kbps</td> </tr> </tbody> </table>		Speed	Data rate	Reader/Writer Tag	1/4	26.48kbps		1/256	1.65kbps	Tag Reader/Writer	26.69kbps	
		Speed	Data rate											
	Reader/Writer Tag	1/4	26.48kbps											
	1/256	1.65kbps												
Tag Reader/Writer	26.69kbps													
Modulation	<table border="1"> <thead> <tr> <th></th> <th>Parameter</th> </tr> </thead> <tbody> <tr> <td>Reader/Writer Tag</td> <td>ASK 10%( 2) / ASK 100%</td> </tr> <tr> <td>Tag Reader/Writer</td> <td>ASK, FSK</td> </tr> </tbody> </table>		Parameter	Reader/Writer Tag	ASK 10%( 2) / ASK 100%	Tag Reader/Writer	ASK, FSK							
	Parameter													
Reader/Writer Tag	ASK 10%( 2) / ASK 100%													
Tag Reader/Writer	ASK, FSK													
Anti-collision	Support													

- 1 : Tag-it HF-I is a registered trademark of Texas Instruments Incorporated.  
my-d is a registered trademark of Infineon Technologies AG.  
I• CODE SLI is a registered trademark of NXP Semiconductors.  
MB89R118 is a registered trademark of FUJITSU Japan.

2 : initialization

Specifications	Item	Parameter																																	
Controll	Command	Please refer to the TR3-Protocol-Manual.																																	
	Host Interface	UART(CMOS) <table border="1" style="margin-left: 20px;"> <thead> <tr> <th>Item</th> <th>Parameter</th> </tr> </thead> <tbody> <tr> <td>Speed</td> <td>9600bps 19200bps( 2) 38400bps</td> </tr> <tr> <td>Data bits</td> <td>8</td> </tr> <tr> <td>Parity</td> <td>None</td> </tr> <tr> <td>Stop bit</td> <td>1</td> </tr> <tr> <td>Flow control</td> <td>None</td> </tr> </tbody> </table>	Item	Parameter	Speed	9600bps 19200bps( 2) 38400bps	Data bits	8	Parity	None	Stop bit	1	Flow control	None																					
	Item	Parameter																																	
Speed	9600bps 19200bps( 2) 38400bps																																		
Data bits	8																																		
Parity	None																																		
Stop bit	1																																		
Flow control	None																																		
LED1	1pc (3 colors, red/green/orange)																																		
Connector	CN1	Connector : JST S10B-PH-SM4-TB(LF)(SN) Housing : JST PHR-10 Contact : JST SPH-002T-P0.5S  Pin assignment <table border="1" style="margin-left: 20px;"> <thead> <tr> <th>Pin No.</th> <th>Symbol</th> <th>Function</th> </tr> </thead> <tbody> <tr><td>1</td><td>VCC</td><td>Power</td></tr> <tr><td>2</td><td>VCC</td><td>Power</td></tr> <tr><td>3</td><td>GND</td><td>GND</td></tr> <tr><td>4</td><td>GND</td><td>GND</td></tr> <tr><td>5</td><td>Rx</td><td>Received data signal</td></tr> <tr><td>6</td><td>Tx</td><td>Transmitted data signal</td></tr> <tr><td>7</td><td>VCC2</td><td>Power output</td></tr> <tr><td>8</td><td>IO1</td><td>Input/Output or Detection signal output H : Detection</td></tr> <tr><td>9</td><td>IO2</td><td>Input/Output or Trigger input L : Trigger ON</td></tr> <tr><td>10</td><td>IO3</td><td>Input/Output</td></tr> </tbody> </table>	Pin No.	Symbol	Function	1	VCC	Power	2	VCC	Power	3	GND	GND	4	GND	GND	5	Rx	Received data signal	6	Tx	Transmitted data signal	7	VCC2	Power output	8	IO1	Input/Output or Detection signal output H : Detection	9	IO2	Input/Output or Trigger input L : Trigger ON	10	IO3	Input/Output
	Pin No.	Symbol	Function																																
1	VCC	Power																																	
2	VCC	Power																																	
3	GND	GND																																	
4	GND	GND																																	
5	Rx	Received data signal																																	
6	Tx	Transmitted data signal																																	
7	VCC2	Power output																																	
8	IO1	Input/Output or Detection signal output H : Detection																																	
9	IO2	Input/Output or Trigger input L : Trigger ON																																	
10	IO3	Input/Output																																	
CN2	Connector : JST S2B-PH-SM4-TB(LF)(SN) Housing : JST PHR-2 Contact : JST SPH-002T-P0.5S  Pin assignment <table border="1" style="margin-left: 20px;"> <thead> <tr> <th>Pin No.</th> <th>Symbol</th> <th>Function</th> </tr> </thead> <tbody> <tr><td>1</td><td>RF</td><td>Analog signal</td></tr> <tr><td>2</td><td>GND</td><td>GND</td></tr> </tbody> </table>	Pin No.	Symbol	Function	1	RF	Analog signal	2	GND	GND																									
Pin No.	Symbol	Function																																	
1	RF	Analog signal																																	
2	GND	GND																																	

2 : initialization

Specifications	Item	Parameter
Mechanical data	Dimensions (W x D x H)	63.8 x 61 x 14.3mm
	Weight	approx. 80g
	Installation	M3 Screw Screw is not included.
Electrical data	Power	Supply Voltage : 5V±10% Current consumption : approx. 120mA Carrier off : approx. 35mA Power down mode : approx. 24mA Consumption : max 1.0W
Ambient Conditions	Temperature Operating range	0 to 55 degree
	Humidity Operating range	30 to 80%RH
	Temperature Storage range	0 to 55 degree
	Humidity Storage range	30 to 80%RH
Other	Accessories	None



Dimensions

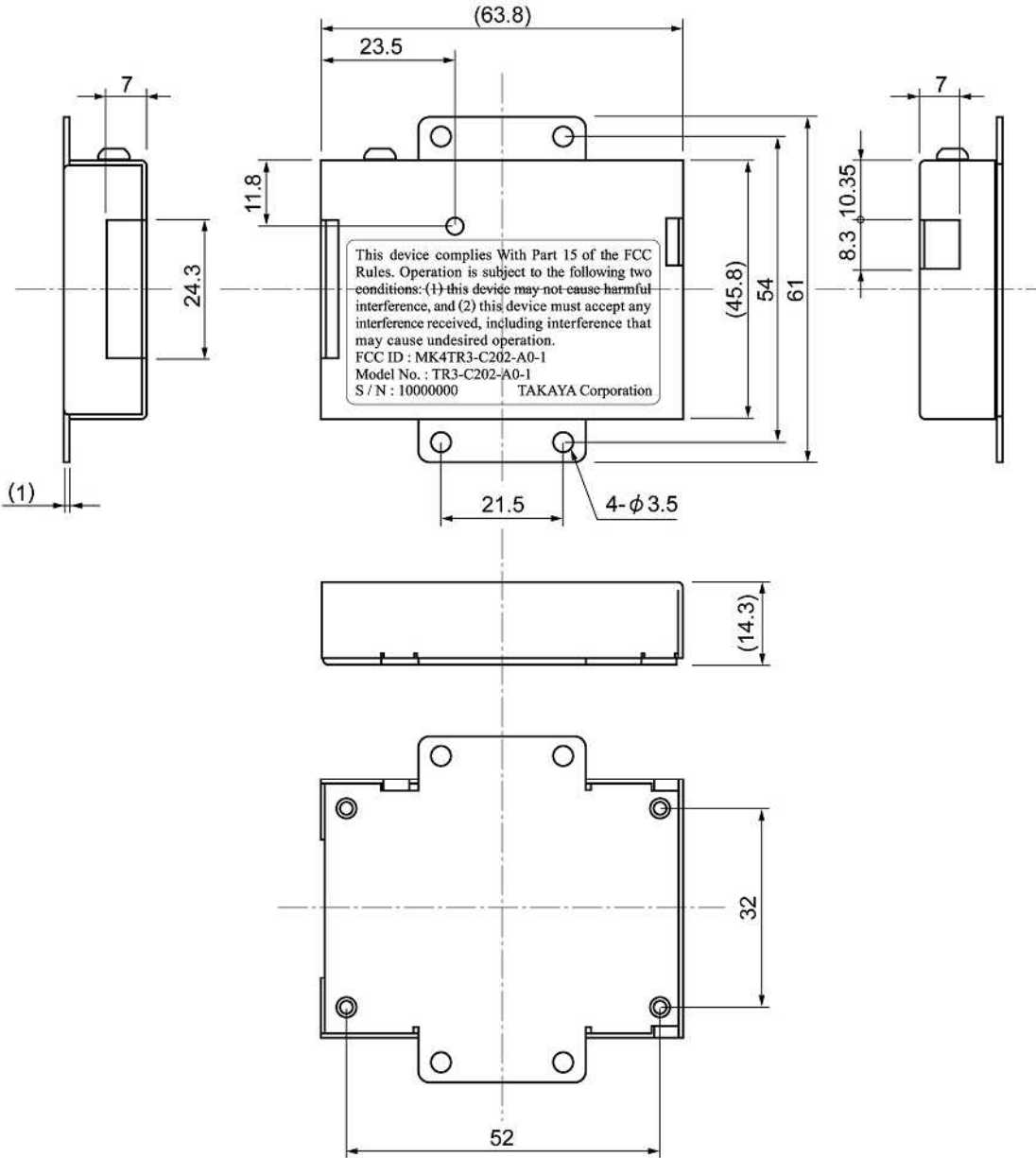

Unit : mm  
 Tolerance :  $\pm 0.3\text{mm}$   
 ( ) is Recommended Dimension  
 Screw hole depth : 3mm

Connections

Names	Model	Notes
Antenna	TR3-A202	
	TR3-A302	
	TR3-A401	
Cable	TR3-AC-1A-***	*** puts the cable length. 9cm ~ 50cm cable are available.
	TR3-AC-2A-***	*** puts the cable length. 10cm ~ 3m cable are available.
Interface board	TR3-IF-1C	RS232C interface
	TR3-IF-N1	TCP/IP interface
	TR3-IF-U1	USB interface

Electrical Characteristics(CN1)

Item	Condition	MIN	TYP	MAX	Unit
H input voltage	RX,IO1,IO2,IO3	2.5		5.0	V
L input voltage	RX,IO1,IO2,IO3	0		1.0	V
H output voltage	IOH=-5mA,-20mA	3.0			V
L output voltage	IOL=5mA,20mA			2.0	V
Pull-up resistor		25.0	50.0	100.0	kΩ

- TX, RX, IO1, IO2 and IO3 is, Pull-up resistor has been connected.
  - TX, RX, IO1, IO2 and IO3 is, 100 ohm resistor has been connected.
- Output port, LED is not driven. If the LED drive, please use the digital transistors.

## 4.2 Antenna

### 4.2.1 TR3-A202 Specifications

Specifications	Item	Parameter							
Applicable Standards	RoHS	EU RoHS(2002/95/EC) Support							
Antenna	Resonant frequency	13.56MHz $\pm$ 40kHz(Ta=25 )							
	Communication distance	Max 10cm (Communication distance depends on the environment.)							
Connector	CN1	Connector : JST S2B-PH-SM4-TB(LF)(SN) Housing : JST PHR-2 Contact : JST SPH-002T-P0.5S							
		Pin assignment <table border="1"> <thead> <tr> <th>Pin No.</th> <th>Symbol</th> <th>Function</th> </tr> </thead> <tbody> <tr> <td>1</td> <td>RF</td> <td>Analog signal</td> </tr> <tr> <td>2</td> <td>GND</td> <td>GND</td> </tr> </tbody> </table>	Pin No.	Symbol	Function	1	RF	Analog signal	2
Pin No.	Symbol	Function							
1	RF	Analog signal							
2	GND	GND							
Mechanical data	Dimensions (W x D x H)	60 x 65 x 9.1 mm							
	Weight	approx. 11g							
	Installation	M3 Screw Screw is not included.							
Ambient Conditions	Temperature Operating range	0 to 55 degree							
	Humidity Operating range	30 to 80% RH							
	Temperature Storage range	0 to 55 degree							
	Humidity Storage range	30 to 80% RH							
Other	Accessories	RFID Sticker 1 sheet Model Name : SEL41400L							

Dimensions

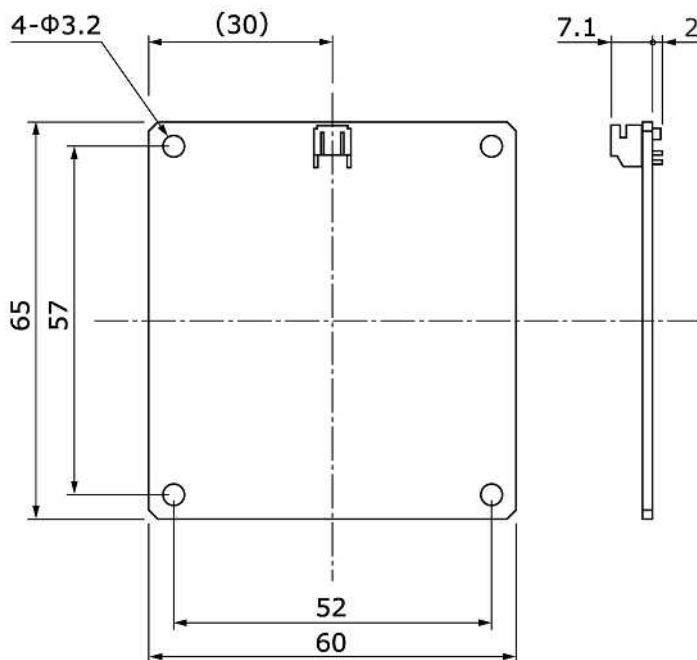

Unit : mm  
Tolerance :  $\pm$ 1mm  
Substrate thickness : 1.6mm

4.2.2 TR3-A302  
Specifications

Specifications	Item	Parameter							
Applicable Standards	RoHS	EU RoHS(2002/95/EC) Support							
Antenna	Resonant frequency	13.56MHz ±40kHz(Ta=25 )							
	Communication distance	Max 7cm (Communication distance depends on the environment.)							
Connector	CN1	Connector : JST S2B-PH-SM4-TB(LF)(SN) Housing : JST PHR-2 Contact : JST SPH-002T-P0.5S							
		Pin assignment <table border="1" style="margin-left: 20px;"> <thead> <tr> <th>Pin No.</th> <th>Symbol</th> <th>Function</th> </tr> </thead> <tbody> <tr> <td>1</td> <td>RF</td> <td>Analog signal</td> </tr> <tr> <td>2</td> <td>GND</td> <td>GND</td> </tr> </tbody> </table>	Pin No.	Symbol	Function	1	RF	Analog signal	2
Pin No.	Symbol	Function							
1	RF	Analog signal							
2	GND	GND							
Mechanical data	Dimensions (W x D x H)	15 x 52.5 x 9.1 mm							
	Weight	approx. 3g							
	Installation	M3 Screw Screw is not included.							
Ambient Conditions	Temperature Operating range	0 to 55 degree							
	Humidity Operating range	30 to 80% RH							
	Temperature Storage range	0 to 55 degree							
	Humidity Storage range	30 to 80% RH							
Other	Accessories	RFID Sticker 1 sheet Model Name : SEL41400L							

Dimensions

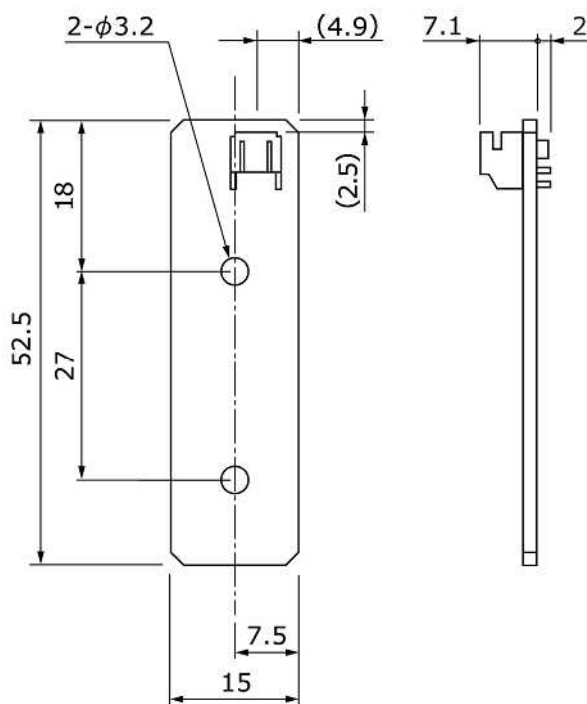

Unit : mm  
Tolerance : ±1mm  
Substrate thickness : 1.6mm

4.2.3 TR3-A401  
Specifications

Specifications	Item	Parameter							
Applicable Standards	RoHS	EU RoHS(2002/95/EC) Support							
Antenna	Resonant frequency	13.56MHz $\pm$ 40kHz(Ta=25 )							
	Communication distance	Max 5cm (Communication distance depends on the environment.)							
Connector	CN1	Connector : JST S2B-PH-K-S(LF)(SN) Housing : JST PHR-2 Contact : JST SPH-002T-P0.5S							
		Pin assignment <table border="1" style="margin-left: 20px;"> <thead> <tr> <th>Pin No.</th> <th>Symbol</th> <th>Function</th> </tr> </thead> <tbody> <tr> <td>1</td> <td>RF</td> <td>Analog signal</td> </tr> <tr> <td>2</td> <td>GND</td> <td>GND</td> </tr> </tbody> </table>	Pin No.	Symbol	Function	1	RF	Analog signal	2
Pin No.	Symbol	Function							
1	RF	Analog signal							
2	GND	GND							
Mechanical data	Dimensions (W x D x H)	15 x 30 x 9.1 mm							
	Weight	approx. 2g							
	Installation	M3 Screw Screw is not included.							
Ambient Conditions	Temperature Operating range	0 to 55 degree							
	Humidity Operating range	30 to 80% RH							
	Temperature Storage range	0 to 55 degree							
	Humidity Storage range	30 to 80% RH							
Other	Accessories	RFID Sticker 1 sheet Model Name : SEL41400L							

Dimensions

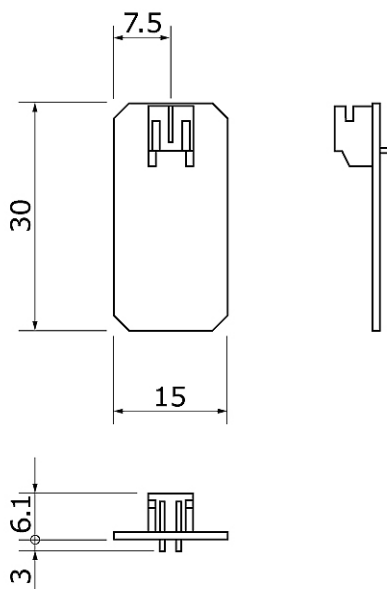

Unit : mm Tolerance : $\pm$ 1mm Substrate thickness : 1.0mm
---

## 4.3 Cable

### 4.3.1 TR3-AC-1A-\*\*\*

Model Name

TR3-AC-1A-\*\*\*

Enter the cable length(Unit:mm)  
090 ~ 500

Specifications

Item	Parameter
RoHS	EU RoHS(2002/95/EC) Support
Linetype	Twisted pair cable
Connector	PH-PH
Cable loss	9cm : approx. 0.061dB 50cm : approx. 0.337dB

Dimensions

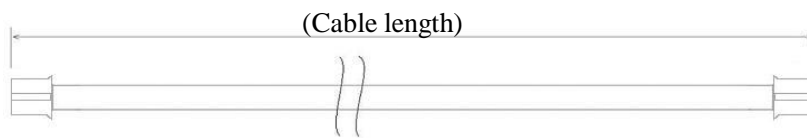

( ) is Recommended Dimension

### 4.3.2 TR3-AC-2A-\*\*\*

Model Name

TR3-AC-2A-\*\*\*

Enter the cable length(Unit:mm)  
100 ~ 3M

Specifications

Item	Parameter
RoHS	EU RoHS(2002/95/EC) Support
Linetype	Coaxial cable 1.5D-2V
Connector	PH-PH
Cable loss	10cm : approx. 0.043dB 3m : approx. 0.255dB

Dimensions

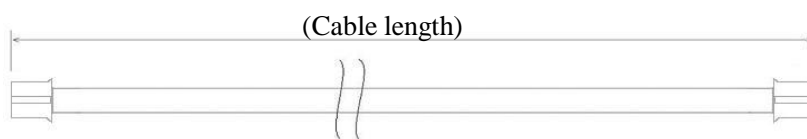

( ) is Recommended Dimension

# 5 Maintenance

This product is mainly used in electronic components and semiconductors. Therefore, the long-term stable operation, the environment and conditions are expected to defect, as shown below.

- Device degradation due to overvoltage and overcurrent.
- Device degradation due to high temperature and long-term stress.
- Poor contact of the connector and cause deterioration of insulation by moisture or dust.
- Connector corrosion by corrosive gases.

In order to use this product at its best, please conduct routine or periodic inspections.

Item		Maintenance	Criteria
Ambient conditions	Temperature	Temperature Operating range	0 to 55 degree
	Humidity	Humidity Operating range	30 to 80%RH
	Enclosure rating	Check the dusty	None
	Corrosive	Check the corrosion	None
Power	Input	Check the voltage	Input Voltage : DC5V±10%
	Voltage fluctuation	Check the Voltage fluctuation	
Attachment	Product	Check the Screw	Checking and verifying
		Check the Connector	
	Cable	Check the Cable break	None
Performance		Check the Performance	Work

---

---

# Revision History

Revision code	Date	Revised contents
1.00	2010/10/28	Original production



---

---

**TAKAYA**

[URL] <http://www.takaya.co.jp/>

[Mail] [rfid@takaya.co.jp](mailto:rfid@takaya.co.jp)

---

---