

Wi-Fi & BT combo Module Datasheet

Model No.: TWM-M7632

TONNLY ELECTRRONICS HOLDINGS LIMMITED.

Address: Section 37, Zhongkai Hi-tech Development Zone, Huizhou Guangdong 516006, P.R.China

Website: <http://www.tonlyele.com>

©20115 TONLY ELECTRONICS HOLDINGS LIMITED. All rights reserved

Legal Notice, Disclaimer, Copyright

This data sheet contains information that is confidential to TONLY ELECTROCICS HOLDINGS LIMITED.

Unauthorized use or disclosure of the information contained herein is prohibited. You may be held responsible for any loss or damages suffered by TONLY ELECTROCICS HOLDINGS LIMITED. For your unauthorized disclosure hereof, in whole or in part.

Information herein is subject to change without noticed. TONLY ELECTROCICS HOLDINGS LIMITED. does not assume any responsibility for any use of, reliance on, the information contained herein THIS DATA SHEET AND ALL INFORMATION CONTAINED HEREIN IS PROVIDED "AS IS" WITHOUT WARRANTY OF ANY KIND, WHETHER EXPRESS, IMPLIED, STATUTORY, OR OTHERWISE. **TONLY ELECTROCICS HOLDINGS LIMITED.** SPECIFICALLY DISCLAIMS ALL IMPLIED WARRANTIES OF MERCHANTABILITY, NON-INFRINGEMENT, AND FITNESS FOR A PARTICULAR PURPOSE. NEITHER DOES **TONLY ELECTROCICS HOLDINGS LIMITED.** PROVIDE ANY WARRANTY WHATSOEVER WITH RESPECT TO THE SOFTWARE OF ANY THIRD PARTY WHICH MAY BE USED BY, INCORPORATED IN, OR SUPPLIED WITH THIS DATA SHEET AND USER AGREES TO LOOK ONLY TO SUCH THIRD PARTY FOR ANY WARRANTY CLAIM RELATING THERETO. **TONLY ELECTROCICS HOLDINGS LIMITED.** SHALL ALSO NOT BE RESPONSIBLE FOR ANY **TONLY ELECTROCICS HOLDINGS LIMITED.** DELIBERABLES MADE TO USER'S SPECIFICATION OR TO CONFORM TO A PARTICULAR STANDARD OR OPEN FORUM.

Tonly is a trademark of TONLY ELECTROCICS HOLDINGS LIMITED. other names mentioned in this document are trademarks/registered trademark of their respective owners.

Document Revision History

Revision	Date	Author	Description
V1.0	2015-12-31	Grant Woo	Frist release
V1.1	2016-04-18	zzhangjiang	<ol style="list-style-type: none"> 1. Additional module logo, legal notice, disclaimer, copyright, certificate and regulation information, package and ordering information, ESD protection, Green policy, recommended temperature reflow profile 2. Confirm RF characteristic
V1.2	2016-07-26	zzhangjiang	<ol style="list-style-type: none"> 1. Update module photos 2. Update module size 3. Update module RF Characteristic 4. Update certificate and regulation

Table of Contents

- Legal Notice, Disclaimer, Copyright
- Document Revision History
- Table of contents
- System overview
- Product Description
- Application Explanation
- Electrical Chart
- RF Characteristic
- Certificate and Regulation information
- Package and Ordering information
- Green Policy
- Recommended Temperature Reflow Profile
- ESD Protection

1. System Overview

1.1 General Descriptions

TWN-M7632 is a IEEE 802.11 a/b/g/n/ac 2T2R Dual Band WLAN Module Integrated Bluetooth 2.1/3.0/4.0 dual mode include BLE

This document is to specify the product specification for IEEE 802.11 a/b/g/n/ac Module. It is based on MTK 7632U chipset that complied with IEEE 802.11 a/b/g/n/ac; The MT7632U is a highly integrated single chip which has built in a 2x2 dual-band wireless LAN radio and Bluetooth radio. It supports IEEE 802.11a/b/g/n standard and provides the highest PHY rate up to 300Mbps, offering feature-rich wireless connectivity and reliable throughput from an extended distance. It includes Bluetooth EDR and LE radio Which complies with Bluetooth v2.1+EDR, v3.0, and v4.0+BLE?

1.2 Features

- Bluetooth® V2.1+EDR, V3.0, V4.0+BLE
- Wi-Fi® IEEE 802.11a/b/g/n/ac 2T2R dual band
- USB V2.0 interface
- Compact 18mm*23mm SMT package
- TCL TONLY Firmware for Controlling
- Wake on WLAN/Bluetooth
- Drivers support Windows

1.3 Block Diagram

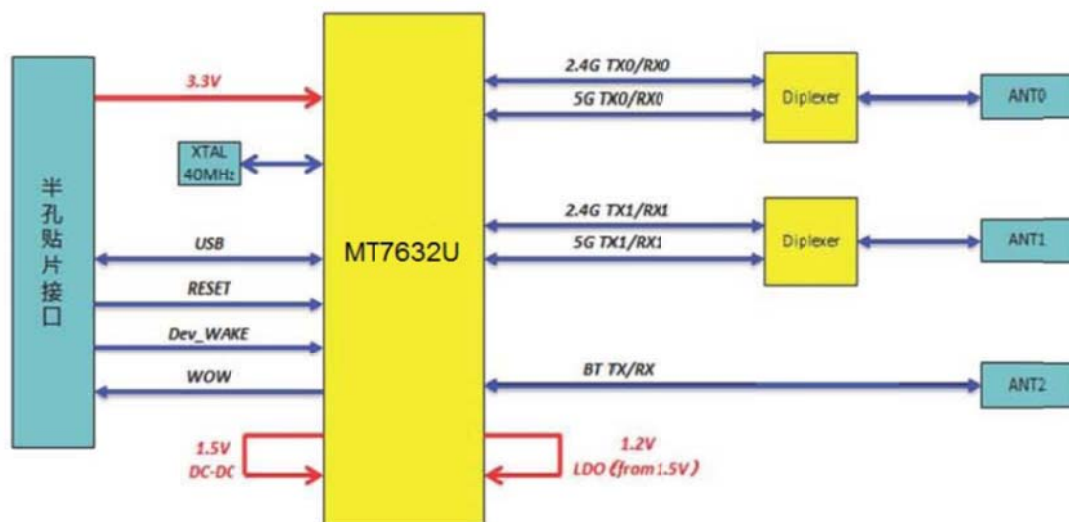

2. Product Description

2.1 Pin Description & Appearance

2.3 Pin Description

PIN No.	Symbol	Description	Remark
1	GND	Ground	GND
2	WL_RF0	WLAN RF in/out 0	In/Out
3	GND	Ground	GND
4	GND	Ground	GND
5	WL_RF1	WLAN RF in/out 1	In/Out
6	GND	Ground	GND
7	GND	Ground	GND
8	BT_RF	Bluetooth RF in/out	In/Out
9	GND	Ground	GND
10	WL_USB_DP	USB D+ signal	In/Out
11	WL_USB_DN	USB D- signal	In/Out
12	VDD (+3.3V)	Positive Supply +3.3V	Power
13	DEV_WAKE	Device Wake Port	In
14	WL_HOST_WAKE	WLAN HOST wake port	In
15	RESET	System Reset	Active low
16	NC	Reserved	N/A

3. Application Explanations

- Soundbar
- Wireless speaker
- DTV

4. Electrical Characteristics

4.1 DC Electrical Characteristics

ELECTRICAL CHARACTERISTICS	
Supply Voltage	DC 3.0 – 3.6V
CURRENT CONSUMPTION	Power supply DC 3.3V
TX/RX active	Max.: 300mA @ RX Max.: 900mA @ TX
WEIGHT AND DIMENSIONS	
Size	18mm * 23mm * 2.3mm (L x W x H)
Weight	1.5g

4.2 Thermal Characteristics

Storage Temperature : -40 ~ + 80°C

Ambient Operating Temperature: 0 ~ 60°C

Junction Temperature: 0 ~ 125°C

5. RF Characteristic

Specification	Description
Bluetooth section-BR&EDR	
Standard	Bluetooth 4.0
Frequency Band	2402 – 2480 MHz
Channel Number	79 Channels
Modulation Method	GFSK, π //4DQPSK,8DPSK
Maximum Data Rate	1/2/3 Mbps
RX Sensitivity	-86 dBm at 0.1% BER GFSK (1Mbps) -86 dBm at 0.1% BER π //4DQPSK (2Mbps) -80 dBm at 0.1% BER 8DPSK (3Mbps)
TX Power	+ 8dBm (Class 1)
Bluetooth section - BLE	
Standard	Bluetooth 4.0
Frequency Band	2402 – 2480 MHz
Channel Number	40 Channels
Modulation Method	GFSK
Maximum Data Rate	1 Mbps
RX Sensitivity	-86 dBm at 0.1% BER GFSK (1Mbps)
TX Power	+ 0 dBm
WLAN Section 802.11n	
Standard	IEEE 802.11 n
Modulation Type	BPSK, QPSK, 16QAM, 64QAM with OFDM
Operating Frequency Range	2.4G band: 2400 – 2483.5MHz 5.0G band: 5150 – 5825 MHz
Data Rate	300 Mbps max.
Transmitter Output Power @ Antenna Connector 25°C (Tolerance \pm 2dB)	2.4G Band/HT20: +15.5 dBm at MCS7 2.4G Band/HT40: +15.5 dBm at MCS7 5.0G Band/HT20: +13.5 dBm at MCS7 5.0G Band/HT40: +13.5 dBm at MCS7
Receiver Sensitivity @ Antenna Connector	2.4G Band HT20 -88dBm at MCS0 -69dBm at MCS7 2.4G Band HT40 -85dBm at MCS0 -68dBm at MCS7 5G Band HT20 -87dBm at MCS0 -66dBm at MCS7 5G Band HT40 -84dBm at MCS0 -63dBm at MCS7
WLAN Section 802.11a	
Standard	IEEE 802.11 a
Modulation Type	BPSK, QPSK, 16QAM, 64QAM with OFDM
Operating Frequency Range	5.0G band: 5150 – 5825 MHz

Channel Numbers	According to Region compliance request
Date Rate	6,9,12,18,24,36,48,54 Mbps
Transmitter Output Power @ Antenna Connector 25°C (Tolerance ±2dB)	+16 dBm at 6/9 Mbps +15 dBm at 12/18 Mbps +14 dBm at 24/36 Mbps +14 dBm at 48/54 Mbps
Receiver Sensitivity @ Antenna Connector	1000PDU, PER<10% @ Temp 25°C -87 dBm at 6 Mbps -69 dBm at 54 Mbps
WLAN Section 802.11b	
Standard	IEEE 802.11 b
Modulation Type	DQPSK, DBPSK, DSSS, CCK
Operating Frequency Range	2400 – 2497 MHz
Channel Numbers	11 channels for USA and Canada 13 channels for Europe and China 14 channels for Japan
Date Rate	11, 5.5, 2, 1 Mbps
Transmitter Output Power @ Antenna Connector 25°C (Tolerance ±2dB)	+17dBm
Receiver Sensitivity @ Antenna Connector	1000PDU, PER<10% @ Temp 25°C -92 dBm at 1 Mbps -82 dBm at 11 Mbps
WLAN Section 802.11a	
Standard	IEEE 802.11 ac
Modulation Type	BPSK, QPSK, 16QAM, 64QAM with OFDM
Operating Frequency Range	5.0G band: 5150 – 5825 MHz
Channel Numbers	According to Region compliance request
Date Rate	58.6, 117, 175.6, 234, 351, 468, 526.6, 585, 702, 780 Mbps
Transmitter Output Power @ Antenna Connector 25°C (Tolerance ±2dB)	+16dBm
Receiver Sensitivity @ Antenna Connector	1000PDU, PER<10% @ Temp 25°C -87 dBm at 58.6 Mbps -69 dBm at 780 Mbps

6. Certificate & Regulation

6.1BQB QDID: 85460

6.2FCC ID: ZVA09

6.3ISED Certification Number: 9976A-09

7. Package & Ordering information

- 60 pcs per every Blister tray
- 600 pcs per every Vacuum packing



8. Green Policy

This module can meet ROHS & REACH compliance.

9. Recommended Temperature Reflow Profile

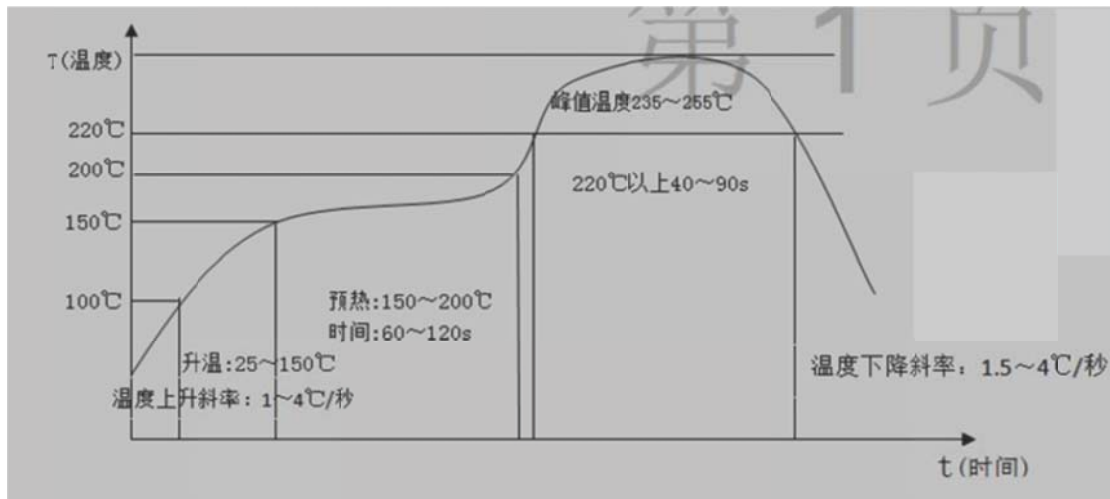

10.ESD Protection

TWM-M7632 is ESD (electrostatic discharge) sensitive) device and may be damaged with ESD or spike voltage. Although TWM-M7632 is with built-in ESD protection circuit, please handle with care to avoid the permanent malfunction or the performance degradation.

FCC Statement

This device complies with part 15 of the FCC rules. Operation is subject to the following two conditions: (1) this device may not cause harmful interference, and (2) this device must accept any interference received, including interference that may cause undesired operation.

Changes or modifications not expressly approved by the party responsible for compliance could void the user's authority to operate the equipment.

NOTE: This equipment has been tested and found to comply with the limits for a Class B digital device, pursuant to part 15 of the FCC Rules. These limits are designed to provide reasonable protection against harmful interference in a residential installation. This equipment generates uses and can radiate radio frequency energy and, if not installed and used in accordance with the instructions, may cause harmful interference to radio communications. However, there is no guarantee that interference will not occur in a particular installation. If this equipment does cause harmful interference to radio or television reception, which can be determined by turning the equipment off and on, the user is encouraged to try to correct the interference by one or more of the following measures:

- Reorient or relocate the receiving antenna.
- Reorient or relocate the receiving antenna.
- Reorient or relocate the receiving antenna.
- Consult the dealer or an experienced radio/TV technician for help important announcement

Important Note:

Radiation Exposure Statement

This equipment complies with FCC radiation exposure limits set forth for an uncontrolled environment. This equipment should be installed and operated with minimum distance 20cm between the radiator and your body.

This transmitter must not be co-located or operating in conjunction with any other antenna or transmitter.

Country Code selection feature to be disabled for products marketed to the US/Canada.

This device is intended only for OEM integrators under the following conditions:

1. The antenna must be installed such that 20 cm is maintained between the antenna and users, and
2. The transmitter module may not be co-located with any other transmitter or antenna,
3. For all products market in US, OEM has to limit the operation channels in CH1 to CH11 for 2.4G band by supplied firmware programming tool. OEM shall not supply any tool or info to the end-user regarding to Regulatory Domain change. (if modular only test Channel 1-11)

As long as the three conditions above are met, further transmitter testing will not be required.

However, the OEM integrator is still responsible for testing their end-product for any additional compliance requirements required with this module installed.

Important Note:

In the event that these conditions cannot be met (for example certain laptop configurations or co-location with another transmitter), then the FCC authorization is no longer considered valid

and the FCC ID cannot be used on the final product. In these circumstances, the OEM integrator will be responsible for re-evaluating the end product (including the transmitter) and obtaining a separate FCC authorization.

End Product Labeling

The final end product must be labeled in a visible area with the following " Contains FCC ID: ZVA09 ".

Manual Information to the End User

The OEM integrator has to be aware not to provide information to the end user regarding how to install or remove this RF module in the user's manual of the end product which integrates this module.

The end user manual shall include all required regulatory information/warning as show in this manual.

Antenna information

The TWM-M7632 has been designed to pass certification with the antenna listed below. The required antenna impedance is 50 ohms.

Model	Type	Connector	Peak gain (dBi)				
			2400-2483.5 MHz	5150-5250 MHz	5250-5350 MHz	5470-5725 MHz	5725-5850 MHz
BAT-POLK-BT	Dipole	RF-SMA	3.0dBi	/	/	/	/
BAT-POLK-WIFI	Dipole	RF-SMA	3.0dBi	3.0dBi	3.0dBi	3.0dBi	3.0dBi
BAT-POLK-WIFI	Dipole	RF-SMA	3.0dBi	3.0dBi	3.0dBi	3.0dBi	3.0dBi

IC Statement

- English: This device complies with Industry Canada license-exempt RSS standard(s). Operation is subject to the following two conditions: (1) This device may not cause interference, and (2) This device must accept any interference, including interference that may cause undesired operation of the device. The digital apparatus complies with Canadian CAN ICES-3 (B)/NMB-3(B).

- French: Le présent appareil est conforme aux CNR d'Industrie Canada applicables aux appareils radio exempts de licence. L'exploitation est autorisée aux deux conditions suivantes: (1) l'appareil ne doit pas produire de brouillage, et (2) l'utilisateur de l'appareil doit accepter tout brouillage radioélectrique subi, même si le brouillage est susceptible d'en compromettre le fonctionnement.

This radio transmitter (ISED certification number: 9976A-09) has been approved by Industry Canada to operate with the antenna types listed with the maximum permissible gain indicated. Antenna types not included in this list, having a gain greater than the maximum gain indicated for that type, are strictly prohibited for use with this device.

Le présent émetteur radio (ISED certification number: 9976A-09) a été approuvé par Industrie Canada pour fonctionner avec les types d'antenne énumérés ci-dessous et ayant un gain admissible maximal. Les types d'antenne non inclus dans cette liste, et dont le gain est supérieur

au gain maximal indiqué, sont strictement interdits pour l'exploitation de l'émetteur.

Antenna information

Model	Type	Connector	Peak gain (dBi)				
			2400-2483.5 MHz	5150-5250 MHz	5250-5350 MHz	5470-5725 MHz	5725-5850 MHz
BAT-POLK-BT	Dipole	RF-SMA	3.0dBi	/	/	/	/
BAT-POLK-WIFI	Dipole	RF-SMA	3.0dBi	3.0dBi	3.0dBi	3.0dBi	3.0dBi
BAT-POLK-WIFI	Dipole	RF-SMA	3.0dBi	3.0dBi	3.0dBi	3.0dBi	3.0dBi

Radiation Exposure Statement

This equipment complies with Canada radiation exposure limits set forth for an uncontrolled environment. This equipment should be installed and operated with minimum distance 20cm between the radiator & your body.

Déclaration d'exposition aux radiations

Cet équipement est conforme Canada limites d'exposition aux radiations dans un environnement non contrôlé. Cet équipement doit être installé et utilisé à distance minimum de 20cm entre le radiateur et votre corps.

This device is intended only for OEM integrators under the following condition:

The transmitter module may not be co-located with any other transmitter or antenna.

As long as the condition above is met, further transmitter test will not be required. However, the OEM integrator is still responsible for testing their end-product for any additional compliance requirements required with this module installed.

Cet appareil est conçu uniquement pour les intégrateurs OEM dans les conditions suivantes:

Le module émetteur peut ne pas être coïmplanté avec un autre émetteur ou antenne.

Tant que les 1 condition ci-dessus sont remplies, des essais supplémentaires sur l'émetteur ne seront pas nécessaires. Toutefois, l'intégrateur OEM est toujours responsable des essais sur son produit final pour toutes exigences de conformité supplémentaires requis pour ce module installé.

Important Note:

In the event that these conditions cannot be met (for example certain laptop configurations or co-location with another transmitter), then the Canada authorization is no longer considered valid and the IC cannot be used on the final product. In these circumstances, the OEM integrator will be responsible for re-evaluating the end product (including the transmitter) and obtaining a separate Canada authorization.

Note Importante:

Dans le cas où ces conditions ne peuvent être satisfaites (par exemple pour certaines configurations d'ordinateur portable ou de certaines co-localisation avec un autre émetteur), l'autorisation du Canada n'est plus considéré comme valide et l' IC ne peut pas être utilisé sur le produit final. Dans ces circonstances, l'intégrateur OEM sera chargé de réévaluer le produit final

(y compris l'émetteur) et l'obtention d'une autorisation distincte au Canada.

End Product Labeling

The final end product must be labeled in a visible area with the following: Contains IC: 9976A-09.

Plaque signalétique du produit final

Le produit final doit être étiqueté dans un endroit visible avec l'inscription suivante: Contient des IC: 9976A-09.

Manual Information to the End User

The OEM integrator has to be aware not to provide information to the end user regarding how to install or remove this RF module in the user's manual of the end product which integrates this module.

The end user manual shall include all required regulatory information/warning as show in this manual.

Manuel d'information à l'utilisateur final

L'intégrateur OEM doit être conscient de ne pas fournir des informations à l'utilisateur final quant à la façon d'installer ou de supprimer ce module RF dans le manuel de l'utilisateur du produit final qui intègre ce module.

Le manuel de l'utilisateur final doit inclure toutes les informations réglementaires requises et avertissements comme indiqué dans ce manuel.

Caution:

- (i) The device for operation in the band 5150–5250 MHz is only for indoor use to reduce the potential for harmful interference to co-channel mobile satellite systems;
- (ii) (ii) For devices with detachable antenna(s), the maximum antenna gain permitted for devices in the bands 5250-5350 MHz and 5470-5725 MHz shall be such that the equipment still complies with the EIRP limit;
- (iii) (iii) For devices with detachable antenna(s), the maximum antenna gain permitted for devices in the band 5725-5850 MHz shall be such that the equipment still complies with the EIRP limits specified for point-to-point and non-point-to-point operation as appropriate; and

Operations in the 5.25-5.35GHz band are restricted to indoor usage only.

Avertissement:

- (i) les dispositifs fonctionnant dans la bande de 5150 à 5250MHz sont réservés uniquement pour une utilisation à l'intérieur afin de réduire les risques de brouillage préjudiciable aux systèmes de satellites mobiles utilisant les mêmes canaux;
- (ii) pour les dispositifs munis d'antennes amovibles, le gain maximal d'antenne permis pour les dispositifs utilisant les bandes de 5250 à 5350MHz et de 5470 à 5725 MHz doit être conforme à la limite de la p.i.r.e;
- (iii) pour les dispositifs munis d'antennes amovibles, le gain maximal d'antenne permis (pour les dispositifs utilisant la bande de 5725 à 5850 MHz) doit être conforme à la limite de la

p.i.r.e. spécifiée pour l'exploitation point à point et l'exploitation non point à point, selon le cas;

Les opérations dans la bande de 5.25-5.35GHz sont limités à un usage intérieur seulement.