

SONY®

4-539-415-11(1)

Home Audio System

Operating Instructions

Getting Started	
Disc	
Tuner	
USB Device	
BLUETOOTH Device	
Other Operations	
Additional Information	

MHC-ECL99BT/MHC-ECL77BT

MHC-ECL99BT/MHC-ECL77BT.4-539-415-11(1)

WARNING

To reduce the risk of fire or electric shock, do not expose this apparatus to rain or moisture.

To reduce the risk of fire, do not cover the ventilation opening of the appliance with newspapers, tablecloths, curtains, etc. Do not expose the appliance to naked flame sources (for example, lighted candles).

To reduce the risk of fire or electric shock, do not expose this appliance to dripping or splashing, and do not place objects filled with liquids, such as vases, on the appliance.

Do not install the appliance in a confined space, such as a bookcase or built-in cabinet.

As the main plug is used to disconnect the unit from the mains, connect the unit to an easily accessible AC outlet. Should you notice an abnormality in the unit, disconnect the main plug from the AC outlet immediately.

Do not expose batteries or appliances with battery-installed to excessive heat, such as sunshine and fire.

The unit is not disconnected from the mains as long as it is connected to the AC outlet, even if the unit itself has been turned off.

CAUTION

The use of optical instruments with this product will increase eye hazard.

Except for customers in the USA and Canada

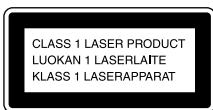

This appliance is classified as a CLASS 1 LASER product. This marking is located on the rear exterior.

Notice for the customers in the USA

Owner's Record

The model and serial numbers are located on the rear of the unit. Record these numbers in the space provided below. Refer to them whenever you call upon your Sony dealer regarding this product.

Model No. _____

Serial No. _____

Important Safety Instructions

- 1) Read these instructions.
- 2) Keep these instructions.
- 3) Heed all warnings.
- 4) Follow all instructions.
- 5) Do not use this apparatus near water.
- 6) Clean only with dry cloth.
- 7) Do not block any ventilation openings. Install in accordance with the manufacturer's instructions.
- 8) Do not install near any heat sources such as radiators, heat registers, stoves, or other apparatus (including amplifiers) that produce heat.
- 9) Do not defeat the safety purpose of the polarized or grounding-type plug. A polarized plug has two blades with one wider than the other. A grounding type plug has two blades and a third grounding prong. The wide blade or the third prong are provided for your safety. If the provided plug does not fit into your outlet, consult an electrician for replacement of the obsolete outlet.
- 10) Protect the power cord from being walked on or pinched particularly at plugs, convenience receptacles, and the point where they exit from the apparatus.
- 11) Only use attachments/accessories specified by the manufacturer.
- 12) Use only with the cart, stand, tripod, bracket, or table specified by the manufacturer, or sold with the apparatus. When a cart is used, use caution when moving the cart/apparatus combination to avoid injury from tip-over.



13) Un
lig
lo
14) Re
pe
th
an
on
sp
ap
ex
no
dr



The f
only
manu
Other
FCC t

NOTE

This e
found
a Clas
Part 1
are de
prote
in a re
equip
radiat
not in
with t
interf

- 13) Unplug this apparatus during lightning storms or when unused for long periods of time.
- 14) Refer all servicing to qualified service personnel. Servicing is required when the apparatus has been damaged in any way, such as power-supply cord or plug is damaged, liquid has been spilled or objects have fallen into the apparatus, the apparatus has been exposed to rain or moisture, does not operate normally, or has been dropped.



This symbol is intended to alert the user to the presence of uninsulated "dangerous voltage" within the product's enclosure that may be of sufficient magnitude to constitute a risk of electric shock to persons.



This symbol is intended to alert the user to the presence of important operating and maintenance (servicing) instructions in the literature accompanying the appliance.

The following FCC statement applies only to the version of this model manufactured for sale in the USA. Other versions may not comply with FCC technical regulations.

NOTE:

This equipment has been tested and found to comply with the limits for a Class B digital device, pursuant to Part 15 of the FCC Rules. These limits are designed to provide reasonable protection against harmful interference in a residential installation. This equipment generates, uses and can radiate radio frequency energy and, if not installed and used in accordance with the instructions, may cause harmful interference to radio communications.

However, there is no guarantee that interference will not occur in a particular installation. If this equipment does cause harmful interference to radio or television reception, which can be determined by turning the equipment off and on, the user is encouraged to try to correct the interference by one or more of the following measures:

- Reorient or relocate the receiving antenna.
- Increase the separation between the equipment and receiver.
- Connect the equipment into an outlet on a circuit different from that to which the receiver is connected.
- Consult the dealer or an experienced radio/TV technician for help.

CAUTION

You are cautioned that any changes or modifications not expressly approved in this manual could void your authority to operate this equipment.

Properly shielded and grounded cables and connectors must be used for connection to host computers and/or peripherals in order to meet FCC emission limits.

This equipment must not be co-located or operated in conjunction with any other antenna or transmitter.

This equipment complies with FCC radiation exposure limits set forth for an uncontrolled environment and meets the FCC radio frequency (RF) Exposure Guidelines. This equipment has very low levels of RF energy that it deemed to comply without maximum permissive exposure evaluation (MPE). But it is desirable that it should be installed and operated keeping the radiator at least 20 cm or more away from person's body (excluding extremities: hands, wrists, feet and ankles).

For customers in Canada

This equipment complies with Industry Canada licence-exempt RSS standard(s). Operation is subject to the following two conditions:

- (1) this equipment may not cause interference, and
- (2) this equipment must accept any interference, including interference that may cause undesired operation of the equipment.

This equipment complies with IC radiation exposure limits set forth for an uncontrolled environment and meets RSS-102 of the IC radio frequency (RF) Exposure rules.

This equipment has very low levels of RF energy that it deemed to comply without maximum permissive exposure evaluation (MPE). But it is desirable that it should be installed and operated keeping the radiator at least 20 cm or more away from person's body (excluding extremities: hands, wrists, feet and ankles).

Disposal of waste batteries and electrical and electronic equipment (applicable in the European Union and other European countries with separate collection systems)



This symbol on the product, the battery or on the packaging indicates that the product and the battery shall not be treated as household waste. On certain batteries

this symbol might be used in combination with a chemical symbol. The chemical symbols for mercury (Hg) or lead (Pb) are added if the battery contains more than 0.0005% mercury or 0.004% lead. By ensuring these products and batteries are disposed of correctly, you will help prevent potentially negative consequences for the environment and human health which could otherwise be caused by inappropriate waste handling. The recycling of the materials will help to conserve natural resources.

In case of products that for safety, performance or data integrity reasons require a permanent connection with an incorporated battery, this battery should be replaced by qualified service staff only. To ensure that the battery and the electrical and electronic equipment will be treated properly, hand over these products at end-of-life to the applicable collection point for the recycling of electrical and electronic equipment.

For all other batteries, please view the section on how to remove the battery from the product safely. Hand the battery over to the applicable collection point for the recycling of waste batteries. For more detailed information about recycling of this product or battery, please contact your local Civic Office, your household waste disposal service or the shop where you purchased the product or battery.

Notice for customers: the following information is only applicable to equipment sold in countries applying EU directives.

This product has been manufactured by or on behalf of Sony Corporation, 1-7-1 Konan Minato-ku Tokyo, 108-0075 Japan. Inquiries related to product compliance based on European Union legislation shall be addressed to the authorized representative, Sony Deutschland GmbH, Hedelfinger Strasse 61, 70327 Stuttgart, Germany. For any service or guarantee matters, please refer to the addresses provided in the separate service or guarantee documents.

Hereby, Sony Corp., declares that this equipment is in compliance with the essential requirements and other relevant provisions of Directive 1999/5/EC.

For details, please access the following URL:
<http://www.compliance.sony.de/>



Note

A Dual...
which...
one si...
the ot...
mater...
Comp...
this p...

Musi... prote...

This p...
discs...
(CD) s...
discs...
techn...
recor...
amon...
do no...
may r...

Hom...
used...
on C...
musi...
stati...
BLUE

Note on DualDiscs

A DualDisc is a two sided disc product which mates DVD recorded material on one side with digital audio material on the other side. However, since the audio material side does not conform to the Compact Disc (CD) standard, playback on this product is not guaranteed.

Music discs encoded with copyright protection technologies

This product is designed to play back discs that conform to the Compact Disc (CD) standard. Recently, various music discs encoded with copyright protection technologies are marketed by some record companies. Please be aware that among those discs, there are some that do not conform to the CD standard and may not be playable by this product.

Home Audio System is designed to be used for playing back music sources on CDs or USB devices, transferring music to USB devices, listening to radio stations, and listening to music on BLUETOOTH devices.

Table of Contents

Guide to parts and controls 7

Getting Started

Hooking up the system
securely..... 10
Inserting batteries 11
Setting the clock..... 11
About the power
management..... 11

Disc

Playing a CD/MP3 disc 12

Tuner

Listening to the radio 14

USB Device

Before using the USB device 15
Transferring music from
a disc..... 16
Playing a file 17

BLUETOOTH Device

About the BLUETOOTH
wireless technology..... 20
Listening to music wirelessly
on a BLUETOOTH device..... 20
Setting the BLUETOOTH audio
codecs..... 24
Setting the BLUETOOTH
standby mode 24
Turning on or off
the BLUETOOTH signal 25
Using "SongPal" via
BLUETOOTH 25

Other Operations

Using an optional audio
component 26
Adjusting the sound..... 26
Changing the display 27
Using the timers 27

Additional Information

Information about compatible
devices 29
Troubleshooting 29
Messages 34
Precautions 34
Specifications..... 36
License and Trademark
Notice..... 39

Guide to parts and controls

This manual mainly explains operations using the remote control, but the same operations can also be performed using the buttons on the unit having the same or similar names.

Unit

For North American, European,
Russian and Australian models

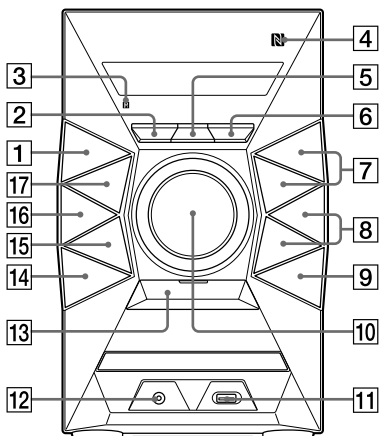

For Mideastern, African and
Latin American models

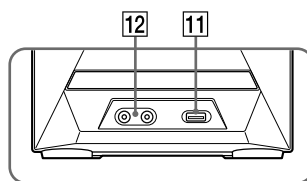





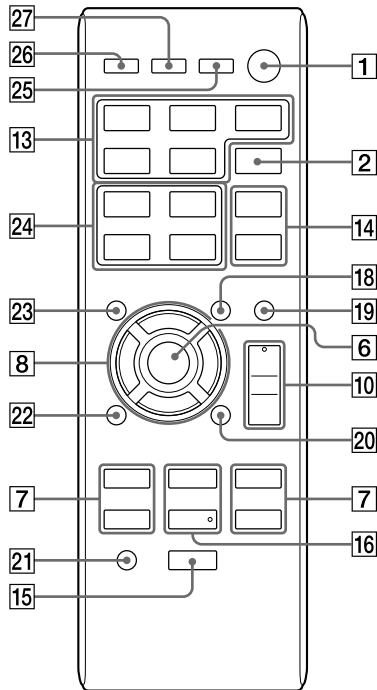

About the child lock function

You can lock the buttons except I/⏻ (on/standby) on the unit to prevent them from being operated by mistake. Hold down ■ (stop) on the unit until "LOCK ON" or "LOCK OFF" appears on the display. The buttons except I/⏻ on the unit will be locked or unlocked.

Remote control



- 1** I/⏻ (on/standby) button
Press to turn on or off the system.
- 2** MEGA BASS button (page 26)
Press to create a more dynamic sound.
- 3** Remote control sensor
- 4**  (N-Mark) (page 22)
Near Field Communication (NFC) touchpoint indication.
- 5** REC TO USB button (page 16)
Press to transfer music from a disc to the connected optional USB device.
- 6** Unit: ENTER button
Remote control: ⊕ button
Press to enter/confirm the settings.

- 7** TUNING+/TUNING- button
Press to tune to the desired station.
◀◀ (go backward)/▶▶ (go forward) button
Press to select a track or file.
◀◀ (rewind)/▶▶ (fast forward) button
Press to find a point in a track or file.
- Remote control: PRESET+/PRESET- button
Press to select a preset radio station.
- 8**  +/ - (select folder) button (page 12, 17)
Press to select a folder.
Unit: PRESET+/PRESET- button
Press to select a preset radio station.
- Remote control:  button
Press to select an item.
- 9**  OPEN/CLOSE button
Press to open or close the disc tray.
- 10** Unit: VOLUME control
Turn to adjust the volume.
Remote control: VOLUME +*/- button
Press to adjust the volume.
- 11**  (USB) port
Connect an optional USB device.
- 12** AUDIO IN jack (for North American, European, Russian and Australian models)
AUDIO IN L/R jacks (for Mideastern, African and Latin American models)
Connect an external audio component.

- 13** **BLUETOOTH (page 21)**
– Press to select the BLUETOOTH function.
– Hold down to activate BLUETOOTH pairing in the BLUETOOTH function.

Unit: BLUETOOTH indicator (page 20)

Remote control: CD button
Press to select the CD function.

Remote control: USB button
Press to select the USB function.

Remote control: AUDIO IN button
Press to select the audio in function.

Remote control: TUNER button
Press to select the tuner function.

- 14** **Unit: EQ button**
Remote control: EQ +/-EQ – button (page 26)
Press to select the preset sound effect.

- 15** **■ (stop) button**
– Press to stop playback.
– Press to stop transfer during music transfer.

- 16** **Unit: ►|| (play/pause) button**
Press to start or pause playback.

Remote control: ► (play)* button
Press to start playback.

Remote control: || (pause) button
Press to pause playback.

- 17** **FUNCTION button**
Press to select the function.

- 18** **PLAY MODE/TUNING MODE button**
– Press to select the play mode of a CD, MP3 disc or USB device (page 12, 17).
– Press to select the tuning mode (page 14).

- 19** **REPEAT/FM MODE button**
– Press to activate repeat playback mode (page 12, 17).
– Press to select the FM reception mode (monaural or stereo) (page 14).

- 20** **OPTIONS button**
Press to enter or exit the option menus.

- 21** **CLEAR button (page 19)**
Press to delete the last step from the program list.

- 22** **RETURN button**
Press to return to the previous display.

- 23** **TUNER MEMORY button (page 14)**
Press to preset the radio station.

- 24** **TUNER MEMORY NUMBER button (page 14)**
Press to tune to a preset radio station.

- 25** **DISPLAY button (page 27)**
Press to change the information on the display.

- 26** **SLEEP button (page 27)**
Press to set the Sleep Timer.

- 27** **TIMER MENU button (page 11, 27)**
Press to set the clock and the Play Timer.

* The VOLUME + and ► buttons on the remote control have a tactile dot. Use the tactile dot as a reference when operating the system.

Getting Started

Hooking up the system securely

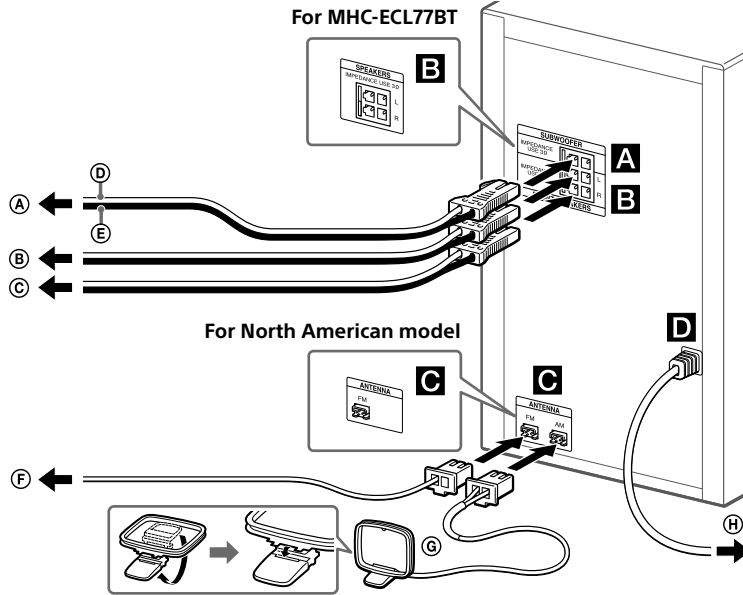

- Ⓐ To subwoofer
- Ⓑ To left speaker
- Ⓒ To right speaker
- Ⓓ Speaker cord (Red/⊕)
- Ⓔ Speaker cord (Black/⊖)

- Ⓕ FM lead antenna (Extend it horizontally.)
- Ⓖ AM loop antenna (except for North American model)
- Ⓗ To wall outlet

Ⓐ SUBWOOFER (MHC-ECL99BT only)

Connect the subwoofer cord to the SUBWOOFER jack. Place the subwoofer vertically to obtain a better bass reproduction. Also, position the subwoofer:

- on a solid floor where resonance is unlikely to occur.
- at least a few centimeters away from the wall.
- away from the center of the room or place a bookshelf against a wall, to avoid generating a standing wave.

Ⓑ FRONT SPEAKERS (MHC-ECL99BT)/SPEAKERS (MHC-ECL77BT)

Connect the speaker cords.

Ⓒ ANTENNA

When inserting the connector of antenna, make sure to insert it in the correct orientation.

Find a location and orientation that provide good reception when you set up the antenna.

Keep the antenna away from the speaker cords and the power cord to avoid picking up noise.

Ⓓ Power

Connect the power cord to a wall outlet.

Attaching the speaker pads

(North American, European, Russian and Australian models only)

Attach the supplied speaker pads to the bottom of the front speakers and subwoofer to prevent them from slipping.

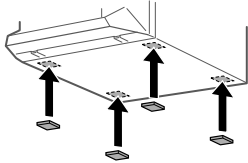

When carrying this system

Make sure that there is no disc loaded and no USB device is connected, and remove the power cord from the wall outlet.

Inserting batteries

Insert an R6 (size AA) battery (supplied), matching the polarity shown below.

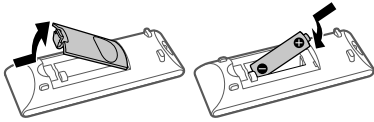

Notes on using the remote control

- With normal use, the battery should last for about six months.
- If you do not use the remote control for a long period of time, remove the battery to avoid damage from battery leakage and corrosion.

Setting the clock

- 1 Press **I/⏻** to turn on the system.
- 2 Press **TIMER MENU** to select the clock set mode.
If "SELECT" appears, press **◀/▶** repeatedly to select "CLOCK," and then press **⊕** (ENTER).
- 3 Press **↑/↓** repeatedly to set the hour, then press **⊕**.
- 4 Use the same procedure to set the minutes.

Notes

- The clock settings are lost when you disconnect the power cord or if a power failure occurs.
- When setting the clock, select a function other than the audio in function beforehand.

To display the clock when the system off

Press **DISPLAY**. The clock is displayed for a few seconds.

About the power management

By default, this system is set to turn off automatically in about 15 minutes when there is no operation, and no audio signal is detected (BLUETOOTH standby mode). For details, see "Setting the BLUETOOTH standby mode" (page 24).

Disc

Playing a CD/MP3 disc

1 Select the CD function.

Press CD.

2 Place a disc.

Press \blacktriangle OPEN/CLOSE on the unit to open the disc tray, then place a disc with the label side up in the disc tray.

3 Press \blacktriangle OPEN/CLOSE on the unit to close the disc tray.

4 Start playback.

Press \blacktriangleright (play).

Other operations

To	Press
Pause playback	II . To resume play, press \blacktriangleright .
Stop playback	\blacksquare . To resume play, press \blacktriangleright . To cancel resume play, press \blacksquare again.
Select a folder on an MP3 disc	$\text{Folder} + / \text{Folder} -$ repeatedly.
Select a track or file	$\text{Left Arrow} / \text{Right Arrow}$.
Find a point in a track or file	Hold down $\text{Left Arrow} / \text{Right Arrow}$ during playback, and release the button at the desired point.
Select Repeat Play	REPEAT/FM MODE repeatedly until "REP ONE" ¹⁾ , "REP FLDR" ²⁾ or "REP ALL" ³⁾ appears.
Change the play mode	PLAY MODE/TUNING MODE repeatedly while the player is stopped. You can select normal play ("FLDR" for all MP3 files in the folder on the disc), shuffle play ("SHUF" or "FLDRSHUF" for folder shuffle), or program play ("PROGRAM").

¹⁾ "REP ONE": Repeats the current track or file.

²⁾ "REP FLDR" (MP3 disc only): Repeats the current folder.

³⁾ "REP ALL": Repeats all tracks or files.

Notes on playing MP3 discs

- Do not save other types of files or unnecessary folders on a disc that has MP3 files.
- Folders that have no MP3 files are skipped.
- MP3 files are played back in the order that they are recorded onto the disc.
- The system can only play MP3 files that have a file extension of ".mp3."
- Even when file name has the correct file extension, if the actual file differs, playing this file may generate a loud noise by which the system may malfunction.
- The maximum number of:
 - folders is 256 (including the root folder).
 - MP3 files is 999.
 - folder levels (the tree structure of files) is 8.
- Compatibility with all MP3 encoding/writing software, recording device, and recording media cannot be guaranteed. Incompatible MP3 discs may produce noise or interrupted audio or may not play at all.

Note on playing multisession discs

The system can play back continuous sessions on a disc when they are recorded in the same session format as the first session. When a session recorded in a different session format is encountered, that session and the ones following it cannot be played back. Note that even if the sessions are recorded in the same format, some sessions may not play back.

Creating your own program (Program Play)

1 Select the CD function.

Press CD.

2 Select the play mode.

Press PLAY MODE/TUNING MODE repeatedly until "PROGRAM" appears while the player is stopped.

3 Select the desired track or file number.

Press ◀▶/▶▶ repeatedly until the desired track or file number appears.

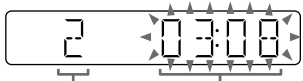

Selected track or file number

Total playing time of the selected track (CD-DA disc only)

When programming MP3 files in a specific folder, press +/ - repeatedly to select the desired folder, and then select the desired file.

4 Program the selected track or file.

Press ⊕ to enter the selected track or file.

5 Repeat steps 3 through 4 to program additional tracks or files, up to a total of 64 tracks or files.

6 To play your program of tracks or files, press ▶.

The program is cleared when you perform one of the following operations:

- changing the function.
- turning off the system.
- disconnecting the power cord.
- opening the disc tray.

To play the same program again, press ▶.

To cancel Program Play

Press PLAY MODE/TUNING MODE.

To delete the last step from the program list

Press CLEAR when playback is stopped.

Disc

Tuner

Listening to the radio

1 Select the tuner function.

For North American model

Press TUNER (or FUNCTION on the unit repeatedly) to select the **FM** function.

For other models

Press TUNER (or FUNCTION on the unit) repeatedly to select the FM or AM function.

2 Perform tuning.

For automatic scanning

Press PLAY MODE/TUNING MODE repeatedly until "AUTO" appears, and then press TUNING+/TUNING-. Scanning stops automatically when a station is found.



If the scanning does not stop, press **■** to stop scanning, then perform manual tuning (below).

For manual tuning

Press PLAY MODE/TUNING MODE repeatedly until "MANUAL" appears, and then press TUNING+/TUNING- repeatedly to tune to the desired station.

When you tune to a station that provides RDS services, the station name appears on the display (European model only).

Hint

To reduce static noise on a weak FM stereo station, press REPEAT/FM MODE repeatedly until "MONO" appears to turn off stereo reception. You will lose stereo effect, but reception will improve.

Presetting radio stations

1 Tune to the desired station.

2 Press TUNER MEMORY to select the tuner memory mode.

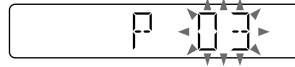

3 Press PRESET+/PRESET- repeatedly to select the desired preset number.

If another station is already assigned to the selected preset number, the station is replaced by the new station.

4 Press **⊕** to store the station.

5 Repeat steps 1 through 4 to store other stations.

The preset stations are retained for about half a day even if you disconnect the power cord or if a power failure occurs.

For North American model

You can preset up to 20 FM stations.

For other models

You can preset up to 20 FM and 10 AM stations.

To tune to a preset radio station

If you registered a radio station to a preset number 1 to 4, the radio station will be tuned in by just pressing the TUNER MEMORY NUMBER (1 to 4) when the tuner function is selected. If you registered a radio station to a preset number 5 or higher, press PLAY MODE/TUNING MODE repeatedly until "PRESET" appears then press PRESET+/PRESET- repeatedly to select the desired preset number.

USB Device

Before using the USB device

For compatible USB devices, see “Information about compatible devices” (page 29). (You can use your Apple devices with this system via BLUETOOTH connection only.)

Notes

- When USB cable connection is necessary, connect the USB cable supplied with the USB device to be connected. See the operation manual supplied with the USB device to be connected for details on the operation method.
- It may take a long time before “SEARCH” appears depending on the type of USB device connected.
- Do not connect the system and the USB device through a USB hub.
- When the USB device is inserted, the system reads all the files on the USB device. If there are many folders or files on the USB device, it may take a long time to finish reading the USB device.
- With some connected USB devices, after an operation is performed, there may be a delay before it is performed by this system.
- Compatibility with all encoding/writing software cannot be guaranteed. If audio files on the USB device were originally encoded with incompatible software, those files may produce noise or interrupted audio, or may not play at all.
- This system does not necessarily support all the functions provided in a connected USB device.
- Do not remove the USB device during transferring or erase operations. Doing so may corrupt the data on the device or damage the device itself.

To use the system as a battery charger

You can use the system as a battery charger for USB devices that have a rechargeable function.

Connect the USB device to the ⏏ (USB) port.

The charging begins when the USB device is connected to the ⏏ (USB) port. For details, see the user’s guide of your USB device.

Transferring music from a disc

You can transfer music from a disc (CD-DA disc or MP3 disc) by using the following transfer modes of this system.

CD SYNC transfer: Transfer all the CD-DA tracks from the CD-DA disc.

MP3 folder transfer: Transfer MP3 files in a specific folder from the MP3 disc.

REC1 transfer: Transfer a currently playing track or MP3 file from the disc.

1 Select the CD function.

Press CD.

2 Connect the USB device to the ψ (USB) port.

3 Load a disc you want to transfer.

4 Prepare for transferring.

Proceed to step 5 in case of CD SYNC transfer.

For MP3 folder transfer

To transfer MP3 files in a specific folder, press +/ - repeatedly to select the folder you want. Then start playback and press once. Make sure the elapsed playing time has stopped on the display.

For REC1 transfer

Press / to select the track or MP3 file you want to transfer, then start playback.

To transfer an MP3 file in a specific folder, press +/ - repeatedly to select the folder you want, then press / to select the MP3 file you want to transfer. Then start playback.

5 Press REC TO USB on the unit.

"READY" appears on the display.

6 Press .

Transferring starts, then "USB REC" appears on the display. Do not remove the USB device until transferring is completed. When transferring is completed, "COMPLETE" appears on the display and audio files in MP3 format will be created.

To stop transfer

Press .

Folder and file generation rules

When first transferring to a USB device, a folder ("CDDA001*", "MP3_REC1" or "CD_REC1") is created directly below the "ROOT" (in case of MP3 folder transfer, a folder that has the same name as the transferring source is created below the "ROOT"). Folders and files are generated as follows.

CD SYNC transfer

Transferring source	Folder name	File name
CD-DA	"CDDA001"*	"TRACK001"*

MP3 folder transfer

Transferring source	Folder name	File name
MP3	Same as the transferring source	

REC1 transfer

Transferring source	Folder name	File name
MP3	"MP3_REC1"	Same as the transferring source
CD-DA	"CD_REC1"	"TRACK001"*

* Folder and file numbers are assigned serially thereafter.

- If you repeat is au
- CD-T the e not s
- Tran – th tr – th or fo re
- If a f to tr devi num over
- Do n or ut trans

The tra use or limit r holder

Notes

- If you start transferring in shuffle play or repeat play mode, the selected play mode is automatically changed to normal play.
- CD-TEXT information is not transferred in the created MP3 files. This system does not support the CD-TEXT standard.
- Transferring stops automatically if:
 - the USB device runs out of space during transferring.
 - the number of audio files and folders on the USB device reaches the limit for the number that the system can recognize.
- If a folder or file that you are trying to transfer already exists on the USB device with the same name, a sequential number is added after the name without overwriting the original folder or file.
- Do not use buttons on the remote control or unit during transferring to prevent transferring from stopping.

Note on copyright-protected content

The transferred music is limited to private use only. Use of the music beyond this limit requires permission of the copyright holders.

Playing a file

The audio formats that can be played back on this system are MP3/WMA*.

* Files with DRM (Digital Rights Management) copyright protection cannot be played back on this system. Files downloaded from an online music store may not be played back on this system.

1 Select the USB function.

Press **USB**.

2 Connect the USB device to the Ψ (USB) port.

3 Start playback.

Press **▶**.

Other operations

To	Press
Pause playback	 . To resume play, press ▶ .
Stop playback	■ . To resume play, press ▶ ¹⁾ . To cancel resume play, press ■ again.
Select a folder	📁 +/ 📁 - repeatedly.
Select a file	◀◀/▶▶ .
Find a point in a file	Hold down ◀◀/▶▶ during playback, and release the button at the desired point.
Select Repeat Play	REPEAT/FM MODE repeatedly until "REP ONE ²⁾ ", "REP FLDR ³⁾ " or "REP ALL ⁴⁾ " appears.
Change the play mode	PLAY MODE/TUNING MODE repeatedly while the USB device is stopped. You can select normal play ("FLDR" for all files in the folder on the USB device), shuffle play ("SHUF" or "FLDRSHUF" for folder shuffle), or program play ("PROGRAM").

USB Device

- 1) When playing a VBR MP3/WMA file, the system may resume playback from a different point.
- 2) "REP ONE": Repeats the current file.
- 3) "REP FLDR": Repeats the current folder.
- 4) "REP ALL": Repeats all files on a USB device.

Notes

- This system cannot play audio files on the USB device in the following cases;
 - when the number of audio files in a folder exceeds 999.
 - when the total number of audio files on a USB device exceeds 999.
 - when the number of folders on a USB device exceeds 256 (including the "ROOT" folder and empty folders).

These numbers may vary depending on the file and folder structure. Do not save other types of files or unnecessary folders on a USB device that has audio files.

- The system can play back to a depth of 8 folders only.
- Files and folders are displayed in the order of their creation on the USB device.
- Folders that have no audio files are skipped.
- The audio formats that you can listen to with this system are as follows:
 - MP3: file extension ".mp3"
 - WMA: file extension ".wma"

Note that even when file name has the correct file extension, if the actual file differs, the system may produce noise or may malfunction.

To erase audio files or folders from the USB device

- 1 Select the USB function.
Press USB.
- 2 Connect the USB device to the ψ (USB) port.
- 3 Press $\blacktriangleleft/\blacktriangleright$ or $\text{Folder} +/\text{Folder} -$ repeatedly to select the audio file or folder you want to erase, then start playback.
- 4 Press OPTIONS.
- 5 Press \uparrow/\downarrow repeatedly to select "ERASE," then press \oplus .
- 6 Press \uparrow/\downarrow to select "FOLDER" or "FILE," then press \oplus .
"ERASE??" flashes on the display.
- 7 Press \oplus .
"COMPLETE" appears on the display.

Creating your own program (Program Play)

1 Select the USB function.

Press USB.

2 Select the play mode.



Press PLAY MODE/TUNING MODE repeatedly until "PROGRAM" appears while the player is stopped.

3 Select the desired file number.

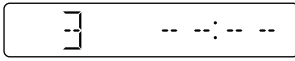
Press ◀▶ repeatedly until the desired file number appears.



Selected file number

When programming MP3/WMA files in a specific folder, press  +/  - repeatedly to select the desired folder, and then select the desired file.

4 Program the selected file.

Press ⊕ to enter the selected file.

5 Repeat steps 3 through 4 to program additional files, up to a total of 64 files.

6 To play your program of files, press ▶.

The program is cleared when you perform one of the following operations:

- changing the function.
- turning off the system.
- disconnecting the power cord.

To play the same program again, press ▶.

To cancel Program Play

Press PLAY MODE/TUNING MODE.

To delete the last step from the program list

Press CLEAR when playback is stopped.

USB Device

BLUETOOTH Device

About the BLUETOOTH wireless technology

BLUETOOTH wireless technology is a short-range wireless technology that enables wireless data communication between digital devices. BLUETOOTH wireless technology operates within a range of about 10 meters (33 feet).

Supported BLUETOOTH version, profiles and codecs

Supported BLUETOOTH version:

- BLUETOOTH Standard version 3.0

Supported BLUETOOTH profiles:

- A2DP (Advanced Audio Distribution Profile)
- AVRCP 1.3 (Audio Video Remote Control Profile)
- SPP (Serial Port Profile)

Supported BLUETOOTH codecs:

- SBC (Sub Band Codec)
- AAC (Advanced Audio Coding) (except for North American model)

Listening to music wirelessly on a BLUETOOTH device

You can listen to music from your BLUETOOTH device over a wireless connection.

About the BLUETOOTH indicator

The BLUETOOTH indicator lights up or flashes in blue to show the BLUETOOTH status.

System status	Indicator status
BLUETOOTH standby	Flashes slowly
BLUETOOTH pairing	Flashes quickly
BLUETOOTH connecting	Flashes
BLUETOOTH connection is established	Lights up

Pairing this system with a BLUETOOTH device

Pairing is an operation where BLUETOOTH devices register with each other beforehand. Once a pairing operation is performed, it does not need to be performed again. If your device is an NFC-compatible smartphone, the manual pairing procedure is not necessary.

1 Place the BLUETOOTH device within 1 meter (3 feet) from the system.

2 Press BLUETOOTH to select the BLUETOOTH function.

If the BLUETOOTH function is selected when the system has no pairing information, the system enters the pairing mode automatically.

Note

If the BLUETOOTH connection is established, terminate the BLUETOOTH connection. See "To terminate the BLUETOOTH connection" (page 23).

3 Hold down BLUETOOTH for 5 seconds or more.

"PAIRING" flashes on the display.

4 Perform the pairing procedure on the BLUETOOTH device.

For details, refer to the operating instructions of your BLUETOOTH device.

5 Select the model number of the unit on the display of the BLUETOOTH device.

For example, select "SONY:MHC-ECL99BT" or "SONY:MHC-ECL77BT."

If passkey is required on the BLUETOOTH device, enter "0000".

6 Perform the BLUETOOTH connection on the BLUETOOTH device.

When pairing is completed and the BLUETOOTH connection is established, "BT AUDIO" appears on the display.

Depending on the BLUETOOTH device, connection may start automatically after pairing is completed.

Notes

- You can pair up to 8 BLUETOOTH devices. If the 9th BLUETOOTH device is paired, the oldest paired device will be deleted.
- "Passkey" may be called "Passcode," "PIN code," "PIN number" or "Password," etc., depending on the device.
- The pairing standby status of the system is canceled after about 5 minutes. If pairing is not successful, repeat from step 1.
- If you want to pair with another BLUETOOTH device, repeat steps 1 to 6.

To cancel the pairing operation

Press **BLUETOOTH**.

Connecting a smartphone with one touch (NFC)

When you touch the system with an NFC-compatible smartphone, the system automatically:

- turns on in the BLUETOOTH function.
- completes pairing.
- completes the BLUETOOTH connection.

What is “NFC”?

NFC (Near Field Communication) is a technology enabling short-range wireless communication between various devices, such as mobile phones and IC tags. Thanks to the NFC function, data communication can be achieved easily just by touching the designated touchpoint on the NFC-compatible devices.

1 Download and install the “NFC Easy Connect” app.

Download the free Android™ app from Google Play™ by searching for “NFC Easy Connect” or access it by using the two-dimensional code below. Data communication fees may be charged.

Two-dimensional code* for direct access

* Use a two-dimensional code reader app.



Notes

- The App may not be available in some countries and/or regions.
- Depending on your smartphone, you can use the NFC function without installing the app. In this case, the operations and specifications may differ. For details, refer to the operating instructions of your smartphone.

Compatible smartphones

Smartphones with a built-in NFC function (OS: Android 2.3.3 or later, excluding Android 3.x)

2 Start the “NFC Easy Connect” app on the smartphone.

Make sure that the application screen is displayed.

3 Touch the smartphone to the N-Mark on the system until the smartphone vibrates.

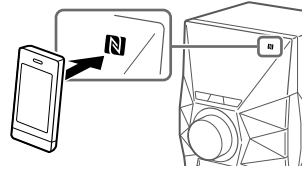

Complete the connection by following the instructions displayed on the smartphone.

When the BLUETOOTH connection is established, the BLUETOOTH indicator stops flashing and remains light up. “BT AUDIO” appears on the display.

You can switch the sound source from the smartphone to another NFC-compatible BLUETOOTH device.

For details, refer to the operating instructions of your BLUETOOTH device.

Hint

If pairing and the BLUETOOTH connection fail, do the following.

- Relaunch “NFC Easy Connect” and move the smartphone slowly over the N-Mark.
- Remove the case from the smartphone if using a commercially available smartphone case.

Listening to music on a BLUETOOTH device

You can operate a BLUETOOTH device by connecting the system and the BLUETOOTH device using AVRCP. Check the following before playing music:

- The BLUETOOTH function of the BLUETOOTH device is turned on.
- Pairing has been completed.

To play music on an NFC-incompatible BLUETOOTH device

1 Press BLUETOOTH to select the BLUETOOTH function.
“BT AUDIO” appears on the display.

2 Establish connection with the BLUETOOTH device.

The last connected BLUETOOTH device will be connected automatically. Perform the BLUETOOTH connection from the BLUETOOTH device if the device is not connected.

3 Press ►.
Depending on the BLUETOOTH device,
– you may need to press ► twice.
– you may need to start playback of an audio source on the BLUETOOTH device.

Notes

- When the system is not connected to any BLUETOOTH device, the system will connect from the last connected BLUETOOTH device automatically when you press ►.
- If you try to connect another BLUETOOTH device to the system, the current connected BLUETOOTH device will be disconnected.

To play music on an NFC-compatible smartphone

Touch the smartphone to the N-Mark on the system to establish the BLUETOOTH connection. Start playback of an audio source on the smartphone. For details on playback, refer to the operating instructions of your smartphone.

To terminate the BLUETOOTH connection

■ For NFC-incompatible BLUETOOTH devices

- 1 Press OPTIONS.
- 2 Press ▲/▼ repeatedly to select “DISCONNECT,” then press ⊕.

Depending on the BLUETOOTH device, the BLUETOOTH connection may be terminated automatically when you stop playback.

■ For NFC-compatible smartphones

Touch the smartphone to the N-Mark on the system again.

Erasing all the pairing registration information

To erase all the pairing registration information, the system should be reset to the factory settings. See “To reset the system to factory settings” (page 33).

Setting the BLUETOOTH audio codecs

(except for North American model)

You can select the BLUETOOTH audio codecs when the connected BLUETOOTH device supports Advanced Audio Coding (AAC).

- 1 Press **OPTIONS**.
- 2 Press **↑/↓** repeatedly to select **"BT AAC,"** then press **⊕**.
- 3 Press **↑/↓** repeatedly to select **"ON"** or **"OFF,"** then press **⊕**.
 - ON: Select this setting if the BLUETOOTH device supports Advanced Audio Coding (AAC).
 - OFF: Select this setting if the BLUETOOTH device only supports Sub Band Codec (SBC).

Notes

- You can enjoy high quality sound if the AAC is selected. In case you cannot listen to AAC sound from your device, select "OFF."
- If you change this setting while the system is connected to a BLUETOOTH device, the BLUETOOTH device will be disconnected. To connect to the BLUETOOTH device, perform the BLUETOOTH connection again.

Setting the BLUETOOTH standby mode

The BLUETOOTH standby mode enables the system to turn off automatically in about 15 minutes when there is no operation, no audio signal is detected, and the automatic standby function (page 33) is turned on.

By default, this mode is enabled.

- 1 Press **OPTIONS**.
- 2 Press **↑/↓** repeatedly to select **"BT:STBY,"** then press **⊕**.
- 3 Press **↑/↓** repeatedly to select **"ON"** or **"OFF,"** then press **⊕**.

When the BLUETOOTH standby mode is set to on, the system waits for a BLUETOOTH connection even when the system has been turned off. When a BLUETOOTH connection is established, the system turns on automatically.

Hint

Disable the BLUETOOTH standby mode to reduce the power consumption in standby mode (eco mode).

Turn BLU

You c
from
in all
BLUE
BLUE
defau

Use t
this o

Hold
abou
"BT O
displa

Note

- You
oper
to ot
– Pa
– Se
– Se
– U
- Whe
off, t
conr
BLU

Turning on or off the BLUETOOTH signal

You can connect to the system from a paired BLUETOOTH device in all functions when the system's BLUETOOTH signal is set to on. The BLUETOOTH signal is turned on by default.

Use the buttons on the unit to perform this operation.

Hold down EQ and ENTER for about 5 seconds.

"BT ON" or "BT OFF" appears on the display.

Notes

- You cannot perform the following operations when BLUETOOTH signal is set to off:
 - Pairing with BLUETOOTH device
 - Setting the BLUETOOTH audio codecs
 - Setting the BLUETOOTH standby mode
 - Using "SongPal" via BLUETOOTH
- When the BLUETOOTH signal is set to off, this system cannot be detected and connection cannot be established from BLUETOOTH device.

Using "SongPal" via BLUETOOTH

(except for North American model)

About App

A dedicated app for this model is available on both Google Play and App Store. Search for "SongPal" and download the free app to find out more about the convenient features.

BLUETOOTH Device

25^{GB}

Other Operations

Using an optional audio component

- 1 Prepare the sound source.**
Connect an optional audio component to the AUDIO IN jack(s) on the unit using an audio analog cord (not supplied).
- 2 Press VOLUME – repeatedly until “VOL MIN” appears on the display.**
- 3 Select the audio in function.**
Press AUDIO IN.
- 4 Start playback.**
Start playback of the connected component and adjust the volume.

Note

The system may enter standby mode automatically if the volume level of the connected component is too low. Adjust the component's volume accordingly. See “To turn off the automatic standby function” (page 33).

Adjusting the sound

To	Press
Adjust the volume	VOLUME +/-.
Generate a more dynamic sound	MEGA BASS.
Set the sound effect	EQ +/-EQ – repeatedly until desired sound effect is displayed.

Cha

To

Chan
inform
on th
displa

* For
such
albu

The s
displa

Displ mode

Power
mode

Notes

- Chan
appe
- The
– to
U
– re
W
- The
– el
fil
ra
– fo
ei
th

Changing the display

To	Press
Change information on the display*	DISPLAY repeatedly when the system is on.

* For example, you can view information, such as track number, file/folder name, album name and artist name.

The system offers the following display mode.

Display mode	When the system is off
Power Saving mode	The display is turned off to conserve power. The clock continues to operate.

Notes on the display information

- Characters that cannot be displayed appear as “_”.
- The following are not displayed;
 - total playing time for an MP3 disc and a USB device.
 - remaining playing time for an MP3/WMA file.
- The following are not displayed correctly;
 - elapsed playing time of an MP3/WMA file encoded using VBR (variable bit rate).
 - folder and file names that do not follow either the ISO9660 Level 1/Level 2 in the expansion format.

Using the timers

The system offers two timer functions. If you use both timers, the Sleep Timer has priority.

Sleep Timer:

You can fall asleep to music. This function works even if the clock is not set.

Press SLEEP repeatedly. If you select “AUTO,” the system automatically turns off after the current disc or USB device stops, or within 100 minutes.

Play Timer:

You can wake up to a CD, FM reception, AM reception (except for North American model) or USB device at a preset time.

Make sure you have set the clock.

1 Prepare the sound source.

Prepare the sound source, and then press VOLUME +/- to adjust the volume.

2 Select the timer set mode.

Press TIMER MENU. If the clock is not set, the system will be in clock set mode. In that case, set the clock.

3 Set the play timer.

Press ◀▶ repeatedly to select “PLAY SET,” then press ⊕.

4 Set the time to start playback.

Press ▲/▼ repeatedly to set the hour, then press ⊕. Follow the same procedure to set the minutes.

5 Follow the same procedure as in step 4 to set the time to stop playback.

6 Select the sound source.

Press ▲/▼ repeatedly until the desired sound source appears, then press ⊕.

7 Turn off the system.

Press I/⏻. The system automatically turns on before the preset time.

If the system is on at the preset time, the Play Timer will not be activated. Do not operate the system from the time the system turns on until the playback starts.

To check the setting

- 1 Press TIMER MENU.
- 2 Press ◀◀/▶▶ repeatedly to select "SELECT," and then press ⊕.
- 3 Press ◀◀/▶▶ repeatedly to select "PLAY SEL," and then press ⊕.

To cancel the timer

Repeat the same procedure as in "To check the setting" until "OFF" appears in step 3, and then press ⊕.

To change the setting

Start over from step 1 of "Using the timers."

Hint

The Play Timer setting remains as long as the setting is not canceled manually.

Additional Information

Information about compatible devices

About supported USB devices

- This system supports USB Mass Storage Class only.
- This system supports FAT formatted USB devices only (except exFAT).
- Some USB devices may not work with this system.

About BLUETOOTH communication for iPhone and iPod touch

Made for

- iPhone 5s
- iPhone 5c
- iPhone 5
- iPhone 4s
- iPhone 4
- iPod touch (5th generation)
- iPod touch (4th generation)

Troubleshooting

- 1 Make sure the power cord and speaker cords are correctly and firmly connected.**
- 2 Find your problem in the checklist below, and take the indicated corrective action.**
If the issue persists, contact your nearest Sony dealer.

If "PROTECT" appears on the display

Immediately unplug the power cord, and check the following items after "PROTECT" disappears.

- Are you using only the supplied speakers?
- Is anything blocking the ventilation holes of the system?

After you have checked these above items and found no problems, reconnect the power cord, and turn on the system. If the issue persists, contact your nearest Sony dealer.

If "OVER CURRENT" appears on the display

A problem has been detected with the level of electrical current from the ⚡ (USB) port. Turn off the system and remove the USB device from the ⚡ (USB) port. Make sure there is no problem with the USB device. If this display pattern persists, contact your nearest Sony dealer.

General

The system does not turn on.

- Is the power cord plugged in?

The system has entered standby mode unexpectedly.

- This is not a malfunction. The system enters standby mode automatically in about 15 minutes when there is no operation or audio signal output. See "Setting the BLUETOOTH standby mode" (page 24) and "To turn off the automatic standby function" (page 33).

The clock setting or the Play Timer operation has been canceled unexpectedly.

- If about a minute elapses with no operation, the clock setting or Play Timer setting is canceled automatically. Perform the operation again from the beginning.

There is no sound.

- Check the speaker connections.
- Are you using only the supplied speakers?
- Is anything blocking the ventilation holes of the system?
- The specified station may have temporarily stopped broadcast.

Sound comes from one channel, or the left and right volumes are unbalanced.

- Place the speakers as symmetrically as possible.
- Connect only the supplied speakers.

There is severe hum or noise.

- Move the system away from sources of noise.
- Connect the system to a different wall outlet.
- Install a noise filter (available separately) to the power cord.

The remote control does not function.

- Remove any obstacles between the remote control and the remote control sensor on the unit, and position the unit away from fluorescent lights.
- Point the remote control at the system's sensor.
- Move the remote control closer to the system.

Except I/⏻, no buttons on the unit work, and "LOCK ON" appears on the display.

- The child lock function has been enabled. To disable the child lock, hold down ■ on the unit until "LOCK OFF" appears on the display.

A disc cannot be ejected and "LOCKED" appears on the display.

- Contact your Sony dealer or local authorized Sony service facility.

CD/MP3 disc

The sound skips, or the disc will not play.

- Wipe the disc clean, and replace it.
- Move the system to a location away from vibration (for example, on top of a stable stand).
- Move the speakers away from the system, or place them on separate stands. At high volume, speaker vibration may cause the sound to skip.

Playback does not start from the first track.

- Set the play mode to normal play mode.

Starting playback takes more time than usual.

- The following discs can increase the time it takes to start playback;
 - a disc recorded with a complicated tree structure.
 - a disc recorded in multisession mode.
 - a disc that has not been finalized (a disc to which data can be added).
 - a disc that has many folders.

USB device

The connected USB device cannot be charged.

- Make sure the USB device is connected securely.

The USB device does not work properly.

- If you connect an unsupported USB device, the following problems may occur. See “Information about compatible devices” (page 29).
 - The USB device is not recognized.
 - File or folder names are not displayed on this system.
 - Playback is not possible.
 - The sound skips.
 - There is noise.
 - A distorted sound is output.

There is no sound.

- The USB device is not connected correctly. Turn off the system, then reconnect the USB device.

There is noise, skipping, or distorted sound.

- Turn off the system, then reconnect the USB device.
- The music data itself contains noise, or the sound is distorted. Noise may have been entered during music creation process using this system or the computer. Create the music data again.
- The bit rate used when encoding the files was low. Send files encoded with higher bit rates to the USB device.

“SEARCH” is displayed for an extended time, or it takes a long time before playback starts.

- The reading process can take a long time in the following cases.
 - There are many folders or files on the USB device.
 - The file structure is extremely complex.
 - The memory capacity is excessive.
 - The internal memory is fragmented.

Erroneous display

- Characters that cannot be displayed appear as “_”.

The USB device is not recognized.

- Turn off the system and reconnect the USB device, then turn on the system.
- See “Information about compatible devices” (page 29).

Transferring results in an error.

- See “Information about compatible devices” (page 29).
- The USB device is not formatted correctly. Refer to the operating instructions of the USB device on how to format.
- Turn off the system and remove the USB device. If the USB device has a power switch, turn the USB device off and then on again after removing it from the system. Then perform transferring again.
- The USB device was disconnected or the power was turned off during transferring. Delete the partially transferred file, and perform transferring again. If this does not fix the problem, the USB device may be broken. Refer to the operating instructions of the USB device on how to deal with this problem.

Audio files or folders on the USB device cannot be erased.

- Check if the USB device is write-protected.
- The USB device was disconnected or the power was turned off during the erase operation. Delete the partially-erased file. If this does not fix the problem, the USB device may be broken. Refer to operating instructions of the USB device on how to deal with this problem.

Playback does not start.

- Turn off the system and reconnect the USB device, then turn on the system.
- See "Information about compatible devices" (page 29).
- Press ► to start playback.

Playback does not start from the first track.

- Set the play mode to normal play mode.

Files cannot be played back.

- The audio files may have inappropriate file extensions. The file extensions supported by this system are as follows:
 - MP3: file extension ".mp3"
 - WMA: file extension ".wma"
- USB storage devices formatted with file systems other than FAT16 or FAT32 are unsupported.*
- If you use a partitioned USB storage device, only files on the first partition can be played back.
- Files that are encrypted or protected by passwords, etc. cannot be played back.

* This system supports FAT16 and FAT32, but some USB storage devices may not support all of these FAT. For details, see the operation manual of each USB storage device or contact the manufacturer.

Tuner

There is severe hum or noise, or stations cannot be received.

- Connect the antenna properly.
- Try another place and orientation for better antenna reception.
- Keep the antenna away from the speaker cords and the power cord to avoid picking up noise.
- Turn off nearby electrical equipment.

BLUETOOTH device

Pairing cannot be performed.

- Move the BLUETOOTH device closer to the system.
- Pairing may not be possible if other BLUETOOTH devices are present around the system. In this case, turn off the other BLUETOOTH devices.
- Make sure to enter the correct passkey when selecting the model number (this system) on the BLUETOOTH device.

Connection is not possible.

- The BLUETOOTH device you attempted to connect does not support the A2DP profile, and cannot be connected with the system.
- Enable the BLUETOOTH function of the BLUETOOTH device.
- Establish a connection from the BLUETOOTH device.
- The pairing registration information has been erased. Perform the pairing operation again.
- Erase the pairing registration information of the BLUETOOTH device by resetting the system to factory settings (page 33) and perform the pairing operation again (page 21).

The sound skips or fluctuates, or the connection is lost.

- The system and the BLUETOOTH device are too far apart.
- If there are obstacles between the system and your BLUETOOTH device, remove or avoid the obstacles.
- If there is equipment that generates electromagnetic radiation, such as a wireless LAN, other BLUETOOTH device, or a microwave oven nearby, move them away.

The sound of your BLUETOOTH device cannot be heard on this system.

- Increase the volume on your BLUETOOTH device first, then adjust the volume using VOLUME +/-.

There is severe hum, noise or distorted sound.

- If there are obstacles between the system and your BLUETOOTH device, remove or avoid the obstacles.
- If there is equipment that generates electromagnetic radiation, such as a wireless LAN, other BLUETOOTH device, or a microwave oven nearby, move them away.
- Turn down the volume of the connected BLUETOOTH device.

To change the AM tuning interval (except for North American, European and Russian models)

The AM tuning interval is preset to 9 kHz or 10 kHz by factory default.

Use buttons on the unit to change the AM tuning interval.

- 1 Tune to any AM station.**
- 2 Hold down MEGA BASS on the unit until "530" (10 kHz) or "531" (9 kHz) appears on the display.**
All the AM preset stations are erased.

To reset the system to factory settings

If the system still does not operate properly, reset the system to factory settings.

- 1 Disconnect and reconnect the power cord, and then turn on the system.**
- 2 Hold down ■ and EQ on the unit until "RESET" appears.**
All user-configured settings, such as preset radio stations, the pairing registration information, timer, and the clock are reset to factory default settings.

To turn off the automatic standby function

This system is equipped with an automatic standby function. With this function, the system enters standby mode automatically in about 15 minutes when there is no operation and no audio signal is detected. By default, the automatic standby function is turned on.

Hold down I/⏻ while the system is on, until "AUTO STANDBY OFF" appears.

To turn on the function, repeat the procedure until "AUTO STANDBY ON" appears.

Notes

- The automatic standby function is invalid for the tuner function.
- The system may not enter standby mode automatically in the following cases:
 - when an audio signal is detected.
 - during playback of audio tracks or files.
 - while the preset Play Timer or Sleep Timer is in process.

Messages

DISC ERR

You have loaded a disc that cannot be played.

ERROR

You cannot transfer music to the USB device because the USB device is write-protected or the memory of the USB device is full.

FULL

You tried to program more than 64 tracks or files (steps).

NO FILE

There are no playable files on the CD-R/CD-RW discs or on the USB device.

NO STEP

All of the programmed steps have been erased.

NO USB

No USB device is connected or an unsupported USB device is connected.

PLAY SET

You tried to select the timer when the Play Timer is not set.

PLS STOP

You pressed PLAY MODE/TUNING MODE during playback.

SELECT

You pressed TIMER MENU during timer operation.

TIME NG

The Play Timer start and end times are set to the same time.

Precautions

Discs that this system CAN play

- Audio CD
- CD-R/CD-RW (audio data/MP3 files)

Discs that this system CANNOT play

- CD-ROM
- CD-R/CD-RW other than those recorded in music CD format, conforming to ISO9660 Level 1/Level 2
- CD-R/CD-RW recorded in multisession that have not ended by "closing the session"
- CD-R/CD-RW of poor recording quality, CD-R/CD-RW that have scratches or are dirty, or CD-R/CD-RW recorded with an incompatible recording device
- CD-R/CD-RW which is finalized incorrectly
- Discs containing files other than MPEG 1 Audio Layer-3 (MP3) files
- Discs of non-standard shape (for example, heart, square, star)
- Discs that have adhesive tape, paper, or sticker attached to them
- Rental or used discs with attached seals where the glue extends beyond the seal
- Discs that have labels printed using ink that feels tacky when touched

Notes on discs

- Before playing, wipe the disc with a cleaning cloth from the center outward to the edge.
- Do not clean discs with solvents, such as benzine, thinner, or commercially available cleaners or anti-static spray intended for vinyl LPs.
- Do not expose discs to direct sunlight or heat sources such as hot air ducts, nor leave them in a car parked in direct sunlight.

On safety

- Completely disconnect the power cord (mains lead) from the wall outlet (mains) if it is not going to be used for an extended period of time. When unplugging the unit, always grip the plug. Never pull the cord itself.
- Should any solid object or liquid get into the system, unplug the system, and have it checked by qualified personnel before operating it again.
- The AC power cord can be changed only by a qualified service facility.

On placement

- Do not place the system in an inclined position or in locations that are extremely hot, cold, dusty, dirty, or humid or lacking adequate ventilation, or subject to vibration, direct sunlight or a bright light.
- Be careful when placing the unit or speakers on surfaces that have been specially treated (for example, with wax, oil, polish) as staining or discoloration of the surface may result.
- If the system is brought directly from a cold to a warm location or is placed in a very damp room, moisture may condense on the lens inside the CD player, and cause the system to malfunction. In this situation, remove the disc, and leave the system turned on for about an hour until the moisture evaporates.

On heat buildup

- Heat buildup on the unit during operation is normal and is not cause for alarm.
- Do not touch the cabinet if it has been used continuously at a high volume because the cabinet may have become hot.
- Do not obstruct the ventilation holes.

On the speaker system

This speaker system is not magnetically shielded, and the picture on nearby TV sets may become magnetically distorted. In this situation, turn off the TV, wait 15 to 30 minutes, and turn it back on.

If there is no improvement, move the speakers far away from the TV.

Cleaning the cabinet

Clean this system with a soft cloth slightly moistened with a mild detergent solution. Do not use any type of abrasive pad, scouring powder, or solvent, such as thinner, benzene, or alcohol.

On BLUETOOTH Communication

- BLUETOOTH devices should be used within approximately 10 meters (33 feet) (unobstructed distance) of each other. The effective communication range may become shorter under the following conditions:
 - When a person, metal object, wall or other obstruction is between the devices with a BLUETOOTH connection
 - Locations where a wireless LAN is installed
 - Around microwave ovens that are in use
 - Locations where other electromagnetic waves occur
- BLUETOOTH devices and wireless LAN (IEEE 802.11b/g) use the same frequency band (2.4 GHz). When using your BLUETOOTH device near a device with wireless LAN capability, electromagnetic interference may occur. This could result in lower data transfer rates, noise, or inability to connect. If this happens, try the following remedies:
 - Try connecting this system and BLUETOOTH device when you are at least 10 meters (33 feet) away from the wireless LAN equipment.
 - Turn off the power to the wireless LAN equipment when using your BLUETOOTH device within 10 meters (33 feet).
- The radio waves broadcast by this system may interfere with the operation of some medical devices. Since this interference may result in malfunction, always turn off the power on this system and BLUETOOTH device in the following locations:
 - In hospitals, on trains, in airplanes, at gas stations, and any place where flammable gases may be present
 - Near automatic doors or fire alarms
- This system supports security functions that comply with the BLUETOOTH specification as a means of ensuring security during communication using BLUETOOTH technology. However, this security may be insufficient depending on the setting contents and other factors, so always be careful when performing communication using BLUETOOTH technology.
- Sony cannot be held liable in any way for damages or other loss resulting from information leaks during communication using BLUETOOTH technology.
- BLUETOOTH communication is not necessarily guaranteed with all BLUETOOTH devices that have the same profile as this system.

- BLUETOOTH devices connected with this system must comply with the BLUETOOTH specification prescribed by the Bluetooth SIG, Inc., and must be certified to comply. However, even when a device complies with the BLUETOOTH specification, there may be cases where the characteristics or specifications of the BLUETOOTH device make it impossible to connect, or may result in different control methods, display or operation.
- Noise may occur or the audio may cut off depending on the BLUETOOTH device connected with this system, the communications environment, or surrounding conditions.

Specifications

Main unit

AUDIO POWER SPECIFICATIONS

POWER OUTPUT AND TOTAL HARMONIC DISTORTION:

(The United States model only)

With 3 ohms loads, both channels driven, from 120 – 10,000 Hz; rated 30 watts per channel minimum RMS power, with no more than 0.7% total harmonic distortion from 250 milliwatts to rated output.

Amplifier section

MHC-ECL99BT

U.S. model:

Front speaker:
Output power (reference):
235 W + 235 W (per channel at 3 ohms, 1 kHz)
Subwoofer:
Output power (reference):
230 W (at 3 ohms, 100 Hz)

Other models:

Front speaker:
Power output (rated):
60 W + 60 W (at 3 ohms, 1 kHz, 1% THD)
Output power (reference):
235 W + 235 W (per channel at 3 ohms, 1 kHz)
Subwoofer:
Output power (reference):
230 W (at 3 ohms, 100 Hz)

MHC-ECL77BT

U.S. model:

Output power (reference):
235 W + 235 W (per channel at 3 ohms, 1 kHz)

Brazilian model:

Output power (reference):
160 W + 160 W (per channel at 3 ohms, 1 kHz)

Other models:

Power output (rated):
60 W + 60 W (at 3 ohms, 1 kHz, 1% THD)
Output power (reference):
235 W + 235 W (per channel at 3 ohms, 1 kHz)

Input

Mideastern, African and Latin American models:

AUDIO IN L/R: Sensitivity 800 mV, impedance 10 kilohms

Other models:

AUDIO IN (stereo mini jack):
Sensitivity 800 mV, impedance
10 kilohms

Outputs

FRONT SPEAKERS (MHC-ECL99BT)/
SPEAKERS (MHC-ECL77BT): Accepts
impedance of 3 ohms
SUBWOOFER (MHC-ECL99BT only):
Accepts impedance of 3 ohms

CD player section

System: Compact disc and digital audio system

Laser Diode Properties

Emission Duration: Continuous

Laser Output*: Less than 44.6 μ W

* This output is the value
measurement at a distance of
200mm from the objective lens
surface on the Optical Pick-up Block
with 7mm aperture.

Tuner section

FM stereo

North American model:

FM superheterodyne tuner

Other models:

FM/AM superheterodyne tuner

Antenna:

FM lead antenna

AM loop antenna (except for North
American model)

FM tuner section:

Tuning range:

North American and Brazilian
models: 87.5 MHz – 108.0 MHz
(100 kHz step)

Other models: 87.5 MHz – 108.0 MHz
(50 kHz step)

AM tuner section (except for North
American model):

Tuning range:

European and Russian models:
531 kHz – 1,602 kHz (9 kHz step)

African and Mideastern models:
531 kHz – 1,602 kHz (9 kHz step)
530 kHz – 1,610 kHz (10 kHz step)

Other models:

531 kHz – 1,710 kHz (9 kHz step)
530 kHz – 1,710 kHz (10 kHz step)

USB section

⚡ (USB) port: Type A, maximum current
1.5 A

BLUETOOTH section

Communication system:

BLUETOOTH Standard version 3.0

Output:

BLUETOOTH Standard Power Class 2

Maximum communication range:

Line of sight approx. 10 m (33 feet)¹⁾

Frequency band:

2.4 GHz band (2.4000 GHz – 2.4835 GHz)

Modulation method:

FHSS (Freq Hopping Spread Spectrum)

Compatible BLUETOOTH profiles²⁾:

A2DP (Advanced Audio Distribution Profile)

AVRCP 1.3 (Audio Video Remote Control Profile)

SPP (Serial Port Profile)

Supported codecs:

SBC (Sub Band Codec)

AAC (Advanced Audio Coding)³⁾

- ¹⁾ The actual range will vary depending on factors such as obstacles between devices, magnetic fields around a microwave oven, static electricity, reception sensitivity, antenna's performance, operating system, software application, etc.
- ²⁾ BLUETOOTH standard profiles indicate the purpose of BLUETOOTH communication between devices.
- ³⁾ Except for North American model

Supported audio formats

Supported bit rate:

MP3 (MPEG 1 Audio Layer-3):

32 kbps – 320 kbps, VBR

WMA*: 32 kbps – 192 kbps, VBR

Sampling frequencies:

MP3 (MPEG 1 Audio Layer-3):

32/44.1/48 kHz

WMA*: 44.1 kHz

* USB devices only

Speaker

Front speaker

North American, European, Russian and Australian models: SS-EC719iP

Other models: SS-ECL77BT

Speaker system: 2-way speaker system, Bass reflex

Speaker units:

Woofers: 160 mm (6 1/2 in), cone type

Tweeter: 40 mm (1 1/2 in), horn type

Rated impedance: 3 ohms

Dimensions (W/H/D):

North American, European, Russian and Australian models: Approx.

230 mm × 300 mm × 205 mm (9 in × 11 3/4 in × 8 1/8 in)

Other models: Approx. 230 mm × 304 mm × 205 mm (9 in × 12 in × 8 1/8 in)

Mass: Approx. 2.5 kg (5 lb 8 1/8 oz) net per speaker

Quantity: 2 pieces

Subwoofer for MHC-ECL99BT only

North American, European, Russian and Australian models: SS-WG919iP

Other models: SS-WEC99BT

Speaker system: Subwoofer system, Bass reflex

Speaker unit: 200 mm (8 in), cone type

Rated impedance: 3 ohms

Dimensions (W/H/D):

North American, European, Russian and Australian models: Approx.

280 mm × 300 mm × 290 mm (11 in × 11 3/4 in × 11 3/8 in)

Other models: Approx. 280 mm × 304 mm × 290 mm (11 in × 12 in × 11 3/8 in)

Mass: Approx. 5.0 kg (11 lb 3/8 oz) net per speaker

Quantity: 1 piece

General

Power requirements:

North American model: AC 120 V, 60 Hz

Mexican and Brazilian models: AC 120 V – 240 V, 60 Hz

Other models: AC 120 V – 240 V, 50/60 Hz

Power consumption:

MHC-ECL99BT: 90 W

MHC-ECL77BT: 75 W

Standby power consumption (at the Power Saving mode):

When BLUETOOTH standby mode is set to off: 0.5 W (eco mode)

When BLUETOOTH standby mode is set to on: 4 W (all wireless network ports on)

Dimensions (W/H/D, including largest protrusions) (excl. speakers):

MHC-ECL99BT: Approx. 193 mm × 300 mm × 260 mm (7 5/8 in × 11 3/4 in × 10 1/4 in)

MHC-ECL77BT: Approx. 193 mm × 300 mm × 260 mm (7 5/8 in × 11 3/4 in × 10 1/4 in)

Mass (excl. speakers):

MHC-ECL99BT: Approx. 3.1 kg (6 lb 13 3/8 oz)

MHC-ECL77BT: Approx. 3.1 kg (6 lb 13 3/8 oz)

Quantity of the main unit: 1 piece

Supplied accessories:

Remote control (1)

R6 (size AA) battery (1)

FM lead antenna (1)

AM loop antenna (1) (except for North American model)

Speaker pads MHC-ECL99BT (12)/ MHC-ECL77BT (8) (North American, European, Russian and Australian models only)

Design and specifications are subject to change without notice.

License and Trademark Notice

- MPEG Layer-3 audio coding technology and patents licensed from Fraunhofer IIS and Thomson.
- Windows Media is either a registered trademark or trademark of Microsoft Corporation in the United States and/or other countries.
- This product is protected by certain intellectual property rights of Microsoft Corporation. Use or distribution of such technology outside of this product is prohibited without a license from Microsoft or an authorized Microsoft subsidiary.
- The BLUETOOTH® word mark and logos are registered trademarks owned by Bluetooth SIG, Inc. and any use of such marks by Sony Corporation is under license. Other trademarks and trade names are those of their respective owners.
- The N Mark is a trademark or registered trademark of NFC Forum, Inc. in the United States and in other countries.
- Android™ is a trademark of Google Inc.
- Google Play™ is a trademark of Google Inc.
- iPhone and iPod touch are trademarks of Apple Inc., registered in the U.S. and other countries. App Store is a service mark of Apple Inc.
- “Made for iPod” and “Made for iPhone” mean that an electronic accessory has been designed to connect specifically to iPod or iPhone, respectively, and has been certified by the developer to meet Apple performance standards. Apple is not responsible for the operation of this device or its compliance with safety and regulatory standards. Please note that the use of this accessory with iPod or iPhone may affect wireless performance.
- All other trademarks and registered trademarks are of their respective holders. In this manual, ™ and ® marks are not specified.



<http://www.sony.net/>



©2014 Sony Corporation Printed in China



* 4 5 3 9 4 1 5 1 1 * (1)