

mr Handsfree[®]
Blue Perfection



Advanced Bluetooth[®] Carkit



SMART MOBILE TECHNOLOGY[™]

GB NL F D I E

P GR HU HR PL SV RU

www.mrhandsfree.com

DECLARATION OF CONFORMITY

We, the undersigned,

Company:	TE-GROUP nv
Address:	Kapelsestraat 61, 2950 Kapellen - BELGIUM

declare, that the following equipment :

Product Name:	mr Handsfree BLUE PERFECTION
Product Type:	Bluetooth® Carkit

Conforms with the requirements of European Council Directive 89/336/EEC amended with 92/31/EEC



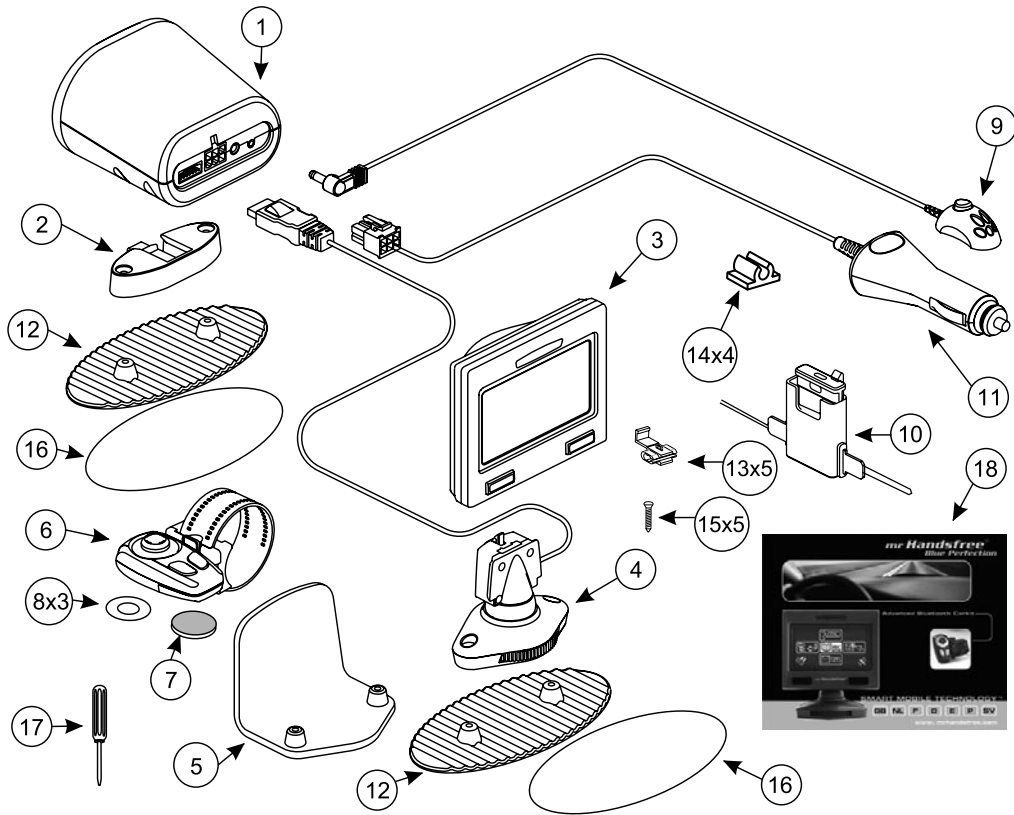

TABLE OF CONTENTS

SAFETY INSTRUCTIONS	2
WHAT DOES MR HANDSFREE BLUE PERFECTION INCLUDE?	2
DESCRIPTION	3
INSTALLATION	6
OPERATION	10
TROUBLE-SHOOTING	23
TECHNICAL PARAMETERS	24
BLUETOOTH®	25
CARE AND TECHNICAL MAINTENANCE	25

SAFETY INSTRUCTIONS

1. Before starting the installation, make sure that the car ignition is off.
2. Make sure that the operation of the carkit will never influence your safety.
3. Make sure not to damage electrical cables, fuel or brake lines or safety equipment during the installation.
4. Make sure not to impact the steering or braking system or other key systems essential for the proper operation of the car when installing the carkit. Make sure that the deployment of the airbags is not blocked or impaired in any way.
5. The carkit may only be used at an operating voltage of 12V with the minus pole earthed. Failure to observe this requirement may result in damage to the car's electronics system.
6. Do not operate your carkit off the car battery for a long time, i.e. with the engine switched off, as this may cause your battery to be empty.

WHAT DOES MR HANDSFREE BLUE PERFECTION INCLUDE?

1. Handsfree unit with built-in speaker **(SM1)**
2. Bracket of the handsfree unit
3. Screen **(D1)**
4. Bracket for the screen with system cord **(SC1)**
5. Angle bracket for fixation of the screen to vertical surfaces
6. Infrared remote control **(J1)**
7. Lithium battery for Infrared remote control, CR2032, 3B
8. Set of decorative inlays for the infrared remote control – 3 pcs.
9. Microphone **(M1)**
10. System cable with adapter for connecting the handsfree unit to the power supply of the car, the ignition system and to mute the radio **(SC2)**
11. Adapter for connecting the handsfree unit to the power supply of the car via the cigarette lighter **(SC3)**. It includes a changeable fuse and coil cord.
12. Fixing plates for the brackets of the screen and the handsfree unit – 2 pcs.
13. Contact clips for connecting the cables – 5 pcs.
14. Clips for guiding the microphone cable – 4 pcs.
15. Set of screws
16. Double sided tape plate - 2 pcs.
17. Screw driver
18. User's manual

DESCRIPTION

HANDSFREE UNIT (SM1)

The handsfree unit includes built-in speaker, echo canceller, noise suppressor and Bluetooth® wireless technology, which provides a wireless connection with Bluetooth® mobile phones.

Since devices with Bluetooth® technology communicate through radio waves, your carkit and your mobile phone do not need to be in direct line-of-sight. The 2 devices only need to be within a maximum of 10 meters of each other, so you do not need to take your phone out of your pocket or bag to make and receive calls via the carkit.

Since Bluetooth® phones produced by different manufacturers provide various functionalities, some functions described in this user's manual could be different or may not be available.

The handsfree unit has the following jacks for connecting external units:

1. Socket for system cable SC1.
2. Socket for cables SC2 and SC3.
3. Socket for external speaker (Use this only with mr Handsfree original accessories).
4. Microphone socket M1.

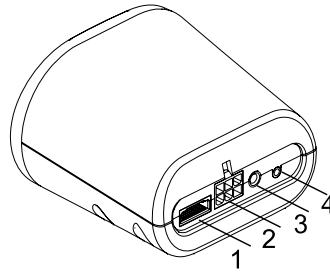

SCREEN (D1)

The screen unit includes:

1. LCD with big symbols and icons.
2. Convenient adjustable fixation system which allows you to choose the best viewing position of the LCD and to release the unit easily from the dashboard to avoid theft.
3. Automatic backlight with variable light colors, contrast and brightness settings.
4. Infrared receiver for the infrared remote control.

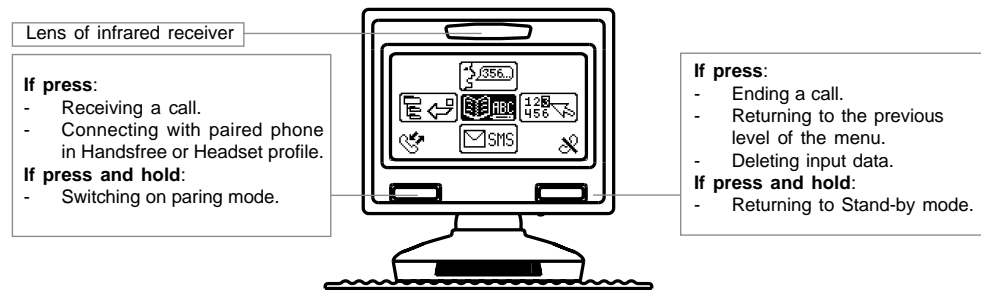

REMOTE CONTROL (J1)

The remote control should be fixed on the steering wheel. It has 2 buttons and a directional joystick. The remote control and its functionality are developed to make access to your mobile phone as easy and clear as possible. The connection between the remote control and the receiver in the screen unit is performed through an infrared channel. The remote control could be fixed on the left or right side of the steering wheel (See chapter "*Installation*").

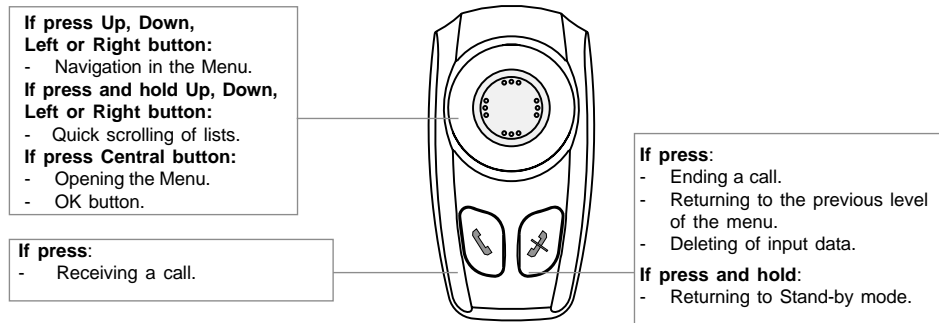

MICROPHONE (M1)

The microphone is developed especially for in-car usage. The location of the microphone significantly influences the acoustic quality (For a recommendation on locating the microphone, see the "Installation" chapter).

The microphone has a 2 positional button for adjusting its sensitivity. Press the button on the microphone to increase the volume to the other caller.

BRACKET FOR SCREEN UNIT WITH SYSTEM CORD SC1

The bracket for the screen unit can be fixed using the fixing wheel (1). The bracket allows you to adjust vertical and horizontal angles of the screen to achieve its best view. On the back side of the bracket there is a button (2) for releasing the screen.

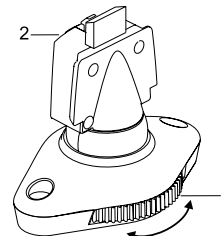

SYSTEM CABLES SC2 AND SC3

The system cable SC2 connects the handsfree unit with the power supply and the ignition system and is used for muting the radio. The system cable SC3 is used for plug & play installation. It provides power supply via the cigarette lighter.

Both system cables are supplied with changeable fuses. How to change the fuses is described in the picture below.

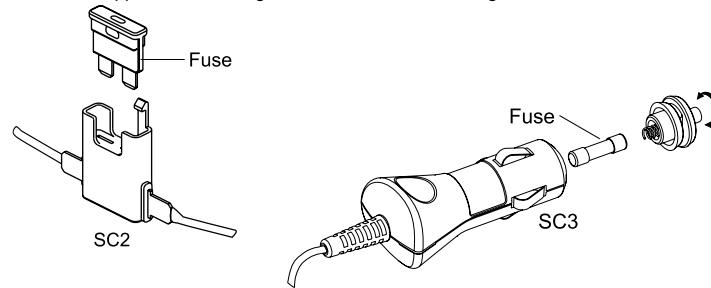

INSTALLATION

HANDSFREE UNIT (SM1)

We recommend mounting the handsfree unit at a less visible position in the car. However, make sure that the unit can provide good acoustic, by directing the speaker towards the user and by placing the unit at a distance of more than 1 meter from the microphone.

Search for a location in your car where the handsfree unit fits and where it is comfortable for use. Make sure that the location in your car where you would like to install your handsfree unit is free from dust and dirt.

The bracket for the handsfree unit should be installed so that the handsfree unit slides into place and could be easily removed if necessary.

The bracket can be fixed in 2 ways:

1. Immediately to the dashboard or to any other place in the car using the installation screws.
2. To the fixing plate using the installation screws. The fixing plate should then be fixed to the dashboard or to any other place in the car by means of the double sided tape plate.

REMOTE CONTROL (J1)

1. Install the lithium battery (1) in the unit in correct polarity (text towards the battery compartment cover) and close the battery compartment.
2. Fix the unit on the bracket by a screw.
3. Click in the decorative inlay (2) and the joystick button (3).
4. Move the remote control into the bracket until it clicks.

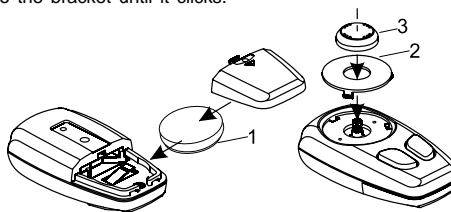

The fixation system of the remote control allows placing the unit on the right or on the left side of the steering wheel. The suggested position for the remote control is at 10 o' clock or 2 o' clock on the steering wheel.

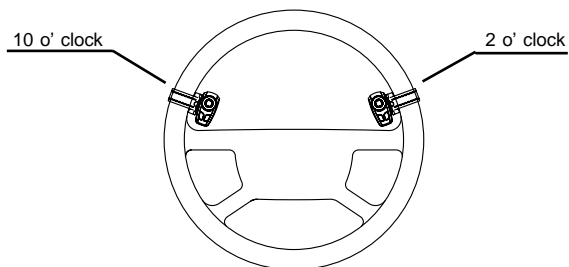

The backside of the remote control is transmitting infrared light and needs to be directed towards the infrared receiver of the screen. Do not cover the backside of the remote control! The screen needs to be placed at the same side of the steering wheel as the remote control. If you have installed the remote control at the right side, you need to install the screen also on the right side.

The fixation needs to be done as it is shown in the picture below.

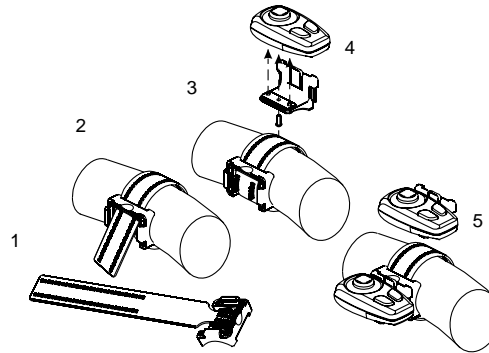

SCREEN UNIT (D1)

Mount the bracket of the screen unit (SC1) on the dashboard or any other place where it is clearly visible, but do not impair control or operation of the vehicle. Take into consideration that the infrared receiver for the remote control is built-in in the screen unit, so for a reliable operation make sure that the screen and the remote control are in visible area at 40-50 cm distance and in an angle of about 30 degrees.

Search for a location in your car where the screen unit fits and where it is comfortable for use. Make sure that the location in your car where you would like to install your screen unit is free from dust and dirt.

The bracket for the screen unit can be fixed in 2 ways:

1. Immediately to the dashboard using the installation screws.
2. To the fixing plate using the installation screws. The fixing plate should then be fixed to the dashboard or to any other place in the car by means of the double sided tape plate.
3. If you want to fix the screen unit on a vertical surface of the dashboard, you can use the angle bracket.

MICROPHONE (M1)

Mount the microphone close to the user's head (30 cm is optimal) and position it so that it is directed towards the mouth. Experience has shown that the best location is near the rearview mirror or to the left of the sun visor. To avoid echo we recommend having a minimum distance of 1 meter between the microphone and the handsfree unit.

Make sure to mount the microphone so that it is not exposed to air streams from the vents. Do not lay the microphone cable in the heating, ventilation or AC systems. Fix the microphone using Velcro.

SYSTEM CABLE (SC1)

The system cable SC1 comes out of the bracket of the screen unit and is used for connecting the screen unit to the handsfree unit via a socket.

Ensure that the cable is placed so that it will not be damaged (e.g. not laid under car seats or over sharp edges).

CONNECTING TO THE POWER

There are 2 ways of connecting the Blue Perfection to the car's electronic system:

1. Plug & play connection: via the adapter for the cigarette lighter (SC3).
2. Built-in connection: immediately to the car's electronic system via system cable SC2.

The wires of the cable SC2 are color coded. They are listed in Table 1 in column A and each wire should be connected to the corresponding item listed in column B.

Table 1.

A	B
Red wire	The + voltage of the car's power supply
Black wire	The negative GND connection
Blue wire	Ignition
Brown wire	Used for Car Radio muting (CRM) and has to be connected to the Car Radio (Mute)

- To avoid distortions make sure that the cables are laid far away from the electronic systems of the car.
- Connect the wires with the contact clips. Put the car wire in the through groove of the clips and the cable wire in the groove with the confining rib.

Attention!

If there is no "Ignition" wire or if it is unavailable, you should connect the blue cable wire to the red wire of the handsfree unit and the red cable wire to the "Discontinuous" wire of the car which keeps the voltage when the ignition is turned off.

CAR RADIO MUTING (CRM)

The Blue Perfection allows muting your Car Radio when there is an incoming call.

- Check the user's manual of your Car Radio to make sure that it has a Mute function. If additional settings have to be set from the Car Radio menu, make sure that they are done correctly.
- Remove the control panel of the Car Radio.
- Remove the decorative panel and take out the Car Radio from the sleeve using the handles. Disconnect the Car Radio plug.

- Connect the wires of the Blue Perfection to the corresponding wires from the car jack or from the ISO jack of the Car Radio according to Table 1. Use 4 contact clips for the connection.
- Restore the connection and installation of the Car Radio.

OPERATION

SWITCHING ON/OFF

If mr Handsfree Blue Perfection is connected to the power via the adapter with cable SC3, you can switch on the unit by clicking the adapter into the cigarette lighter.

If mr Handsfree Blue Perfection is connected to the power with cable SC2, the unit will switch on automatically when you turn the ignition key.

Mr Handsfree Blue Perfection will turn off automatically when the ignition is off.

MENU STRUCTURE

All functions of the unit are grouped in the menu.

To access the menu press the central button of the joystick once. The menu of quick access appears on the display.



To move in the menu, use the joystick and the 2 control buttons of the remote control.
The menu structure is shown below:

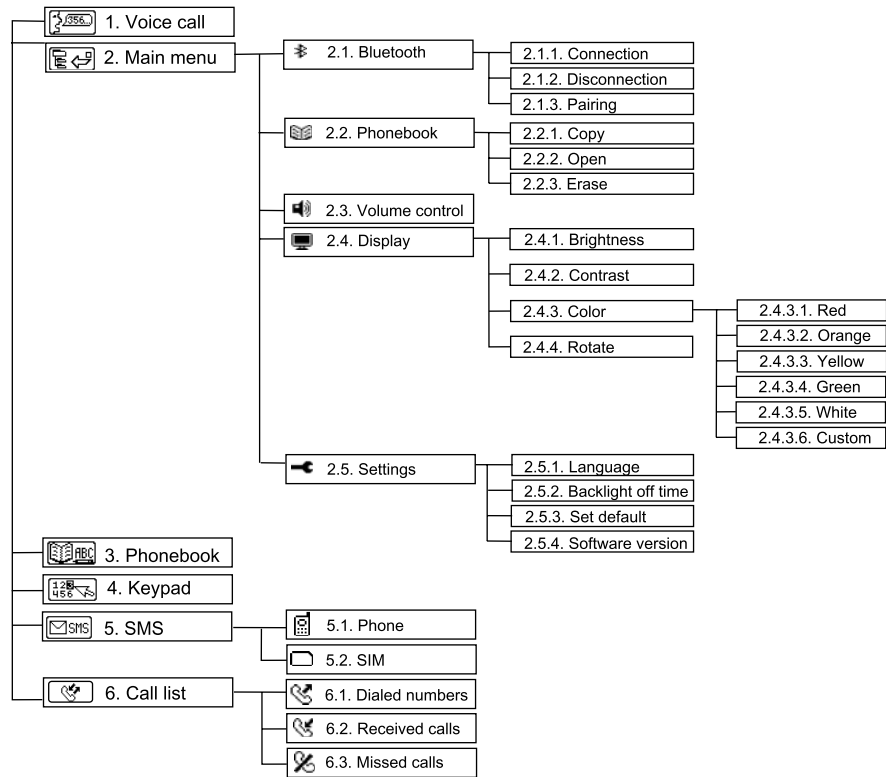

PAIRING, CONNECTION AND DISCONNECTION

A. PAIRING

- For pairing mr Handsfree Blue Perfection with your Bluetooth® mobile phone, use the remote control to go to **Main menu** ⇒ **Bluetooth** ⇒ **Pairing** and press . Now mr Handsfree Blue Perfection is in registration mode. The corresponding message appears on the display and a confirmation tone will be heard.



- Activate the Bluetooth® function in your mobile phone.
- Search for available Bluetooth® devices by entering the corresponding submenu of the phone. Your phone will find all Bluetooth® devices within 10 m distance and display them as a list.
- Select *"BLUE PERFECTION"* from the list.
- Enter the passkey "0000". *"PAIRING OK"* will appear on the display and the device will turn to Standby mode. "Blue Perfection" will be stored in the list of paired devices in your phone.

Note:

If necessary, the pairing mode could be activated by pressing the left button on the screen unit. The button should be pressed and held for more than 5 sec.

B. CONNECTION

In some cases the device could be disconnected from your phone. For example, if the Blue Perfection was switched off. To restore the connection between the Blue Perfection and your phone:

- Switch on the power and the connection will be restored automatically; OR
- Use the joystick to go to **Main menu** ⇒ **Bluetooth** ⇒ **Connection**. *"CONNECTION.."* will appear on the display; OR
- Press and hold the left button on the screen unit for more than 5 sec.

C. DISCONNECTION

Sometimes you need to disconnect your phone from the Blue Perfection. For example, if the phone should communicate with another Bluetooth® device.

To disconnect the Blue Perfection and your phone:

- Switch off the Blue Perfection; OR
- Select the menu item: **Main menu** ⇨ **Bluetooth®** ⇨ **Disconnection**; OR
- Take the phone away from the Blue Perfection on more than 10 meters; OR
- Disconnect the Blue Perfection and the phone through the phone's menu.

Note:

If the Blue Perfection and your phone were disconnected and you want to connect them again, it is not necessary to pair these devices again. Restoring the connection will be performed without asking for the access code.

FUNCTIONS

1. VOICE DIALING

If your phone supports voice dialing and there are saved voice tags (names), you can use this function via the Blue Perfection.

2. MAIN MENU

2.1 Bluetooth®



2.1.1 Connection

Use this item to connect the Blue Perfection and your phone.

2.1.2 Disconnection

Use this item for destroying the connection between the Blue Perfection and your mobile phone.

2.1.3 Pairing

Use this item to pair the Blue Perfection and your Bluetooth® mobile phone.

2.2 Phonebook settings



2.2.1 Copy

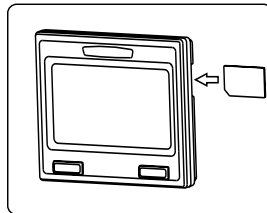

Use this item to copy the phonebook of your phone to the Blue Perfection phonebook. The maximum number of phonebook records is 200.

Since not all Bluetooth® phones support phonebook copying using Bluetooth®, you can also use the built-in SIM card reader to download your phonebook data in the Blue Perfection memory. To copy the phonebook using the SIM card reader, please disconnect the screen from the bracket SC1, insert the SIM card into the SIM card holder according to the picture, and connect the screen to the bracket. Make sure that you push the card deep enough, until it clicks into place.

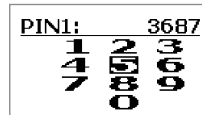

If the SIM card is PIN code protected, the screen keypad will appear:



- Enter the PIN code by using the Up, Down, Left and Right buttons to select digits.
- Use  to confirm your choice. The selected digits will appear on the top part of the display.
- To delete an incorrect digit, press .
- Press  to confirm the PIN code.
- The phonebook copying will start accordingly. The existing phonebook, stored in the Blue Perfection, will be erased automatically.
- If your SIM card is not PIN code protected, the phonebook copying process will start automatically.
- As soon as the phonebook copying process is finished, you can disconnect the screen from the bracket and remove the SIM card from the holder. To release the card from the holder, you should press it.

- Insert the SIM card in your mobile phone and switch it on.
- Connect the screen to the bracket.
- Activate the main menu of the Blue Perfection and select **Bluetooth®** ⇔ **Connection**.
- Press  to confirm your choice.
- The connection should be restored.

2.2.2. Open

Use this item to view the phonebook records.

2.2.3. Erase

Use this item to delete all the phonebook records.

2.3 Volume of conversation and call ring

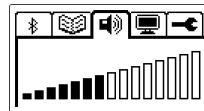

This item is used for setting the desired volume of the speaker of the Blue perfection in Talk mode and the volume of the incoming call ringer.

Use the Up and Down buttons of the joystick to set the volume. There are 16 volume-levels.



2.4 Display settings



2.4.1 Brightness

Choose this menu item for setting the brightness of the display backlight.





- Use the Up and Down buttons of the joystick to choose the desired brightness.
 - Press  to confirm or  to restore the previous setting of the brightness.
- The custom setting of brightness has 16 levels. Level 0 switches the backlight off, level 15 is the maximum.

2.4.2 Contrast

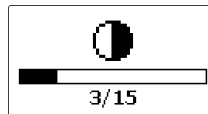
Choose this menu item for setting the contrast of the display.



- Use the Left and Right buttons of the joystick to choose the desired contrast.
 - Press  to confirm or  to restore the previous setting of the contrast.
- The contrast has 16 levels. Level 0 is the minimum, level 15 is the maximum.

2.4.3 Color



Choose this menu item for setting the color of the display backlight.

Choose one of the available colors:

1. Red
2. Orange
3. Yellow
4. Green
5. White
6. Custom

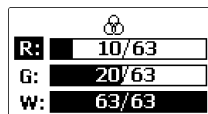
Choose the menu item "CUSTOM" to set the color of the backlight smoothly.



- Use the Up and Down buttons of the joystick to choose the desired color.
- Use the Left and Right buttons of the joystick to choose the desired level of the color.
- Press  to confirm or  to restore the previous setting of the color.

2.4.4 Rotate

For mounting in upside down position, you can rotate the screen.



Choose the menu item "ROTATE" and press  to confirm.

2.5 Settings



2.5.1 Language

Choose the menu item "SETTINGS" .



- Choose the "LANGUAGE" item and press .
- Choose one of the available languages (English, Russian, Dutch ...).
- Press  to confirm or  to restore the previous setting of the language.





2.5.2 Backlight off time

- Choose "BACKLIGHT OFF TIME" to set the time after which the backlight will be switched off.
- Press .
- Use the Left and Right buttons of the joystick to set the timer. If you chose "ALWAYS ON", the backlight will not be switched off. Timer steps are 10 sec, the maximum is 1 min.
- Press  to confirm or  to restore the previous setting and exit the menu.



2.5.3 Set Default

With this item you can restore the factory settings of the Blue Perfection.

Parameter	Value
Brightness	15/15 (max)
Contrast	8/15 (mid)
Backlight Color	White
Language	English
Backlight off time	10 sec

- In the submenu "SETTINGS" , select the item "SET DEFAULT" and press  to confirm.
- "SET DEFAULT" will appear on the display. Press  to confirm or  to cancel.

2.5.4 Software version

- In the submenu "SETTINGS" , select the item "SOFTWARE VERSION" and press  to confirm.
- The number of the software version will appear on the display.

3. PHONEBOOK

You can use the phonebook for dialing out. The records of the phonebook are displayed in alphabetical order in the top part of the display. The Blue Perfection phonebook can store up to 200 records. For a quick search of the desired name, find its first letter with the cursor in the bottom part of the display using the navigation buttons of the joystick. The phonebook copying process is described in chapter 2.2.1.

4. LCD KEYPAD

- By using the LCD keypad and the joystick of the remote control you can dial out any number.
- Use the Up, Down, Left and Right buttons of the joystick to move and choose a digit on the display.
 - Press the  button to confirm.

Note:

The cursor always moves back to "5" after you have selected a digit. This is because the "5" is close to all of the other digits.

5. SMS

With this item of the menu you can copy received SMS from your phone's memory or SIM card (up to 20). You will see the first word of each message. By clicking these words, you will open the message and see more details.

Note:

This function is not supported by some mobile phones due to their specific functionality.

6. CALL LIST

This item of the menu could be accessed by a single press of the  button on the remote control when you are in the main menu. Then you can choose 1 of 3 lists:

- List of outgoing calls.
- List of incoming calls.
- List of missed/rejected calls.

Every list can store up to 10 numbers and names if they are saved in the phonebook.

MAKING CALLS

1. STAND-BY MODE

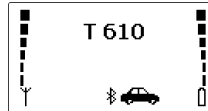

In Stand-by mode the display shows the current parameters of your phone:

1. Signal strength of the cellular network at the current location. The higher the bars, the stronger the signal. The number of bar-segments may differ slightly from your phone due to Bluetooth® implementation for this software.
2. Capacity of the battery. The higher the capacity, the more bars. If the battery is almost discharged, the icon will flash. If the phone is in charging mode, the charger icon will appear near the battery icon.
3. The Bluetooth® name of the connected mobile phone.
4. If the Bluetooth® connection is activated, there will be a "Car" icon on the display.



2. VOICE DIALING

Before using this function, make sure that you have saved voice tags for voice dialing in your phone.

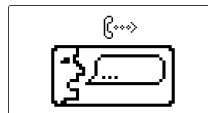

- To activate voice dialing, press  and select the item "VOICE CALL"  in the menu.
- Press .
- The below picture will appear on the display.



- After the beep, say the tag.
- The Blue Perfection will record the corresponding tag from its memory and dial the number.

3. DIALING FROM THE PHONEBOOK

You can dial a number from the phonebook stored in the Blue Perfection memory.

- In Stand-by mode, press  to enter the Menu and select the item "PHONEBOOK" .
- Press .
- The below picture will appear on the display.

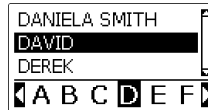

- Use the Left and Right buttons to move in the bottom part of the display and to select the first letter of the name.
- Use the Up and Down buttons to scroll through the phonebook list.
- Press to view detailed information of the record (name and phone number).
- Press to return to the Phonebook.
- Press for dialing.

Note:

The bottom line with the letters only contains the letters corresponding to the phonebook records.

4. DIALING FROM THE LCD KEYPAD

You can use the LCD keypad to enter a number.

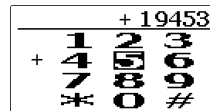

- In Stand-by mode, press to enter the Menu and select the item "KEYPAD"
- Press .
- The following keypad will appear on the display:



- Use the Up, Down, Left and Right buttons to select digits.
- Use to confirm the choice. Selected digits will appear on the top part of the display. After every selection the cursor will return to the center of the numerical keypad, to digit "5".
- To delete an incorrect digit, press .
- Press to dial the number.

5. REDIAL

Redial is done from the call lists. By selecting the outgoing call list, you can redial the last 10 numbers that have been dialed with the Blue Perfection after switch on.



- In Stand-by mode, press  and then .
- Three lists will appear on the display:



You can choose the desirable number from every list:

- Outgoing calls.
- Incoming calls.
- Missed/rejected calls.

The maximum capacity of every list is 10 records. If a number was stored in the phonebook, the name will be displayed.





- To move from one list to another, use the Left and Right buttons.
- To scroll the lists, use the Up and Down buttons.
- Press  to dial the number.
- Press  to return to Stand-by mode.

6. DURING A CALL

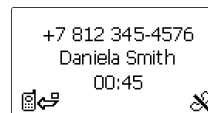
During a call, the display shows the following information:

1. Telephone number.
2. Name.
3. Duration of a call.
4. Icons of the remote control buttons.



- During a call you can adjust the volume using the Up and Down buttons.
- Transfer the call from the Blue Perfection to the phone by pressing .
- Transfer a call from the phone to the Blue Perfection through the corresponding item in the phone's menu.
- If you need to dial the DTMF command, press  and the screen keypad will appear.
- Use the Up, Down, Left and Right buttons to select the digits.
- Use  to confirm your choice. The selected digits will appear on the top part of the display.
- To delete an incorrect digit, press .
- Press  to send the DTMF command.

7. ENDING A CALL

Press  to end a call.

8. ANSWERING A CALL

If there is an incoming call, the number of the caller will appear on the display.

If the name and number are stored in the Phonebook of the Blue Perfection the name will appear on the display as well.







Press  to answer a call.



9. REJECTING A CALL

If you do not want to receive a call press .

SMS

OVERVIEW LIST OF SMS

- To view the SMS list in Stand-by mode, press , choose the item "SMS"  and press  again.
- The SMS list of the phone memory will be displayed.
- Move the joystick to the right to view SMS from the SIM card memory.
- Choose an SMS and press  to view it.

- Press  to see the telephone number/name of the SMS sender and the message receiving date and time.
- Press  to dial this telephone number.
- Press  to exit the SMS viewing mode.

TROUBLE-SHOOTING

Problem	Reason	Elimination
The device does not work. The green LED of the Power Adapter is off.	<ol style="list-style-type: none"> 1. The cigarette lighter jack is damaged. 2. No contact between the Power Adapter and the cigarette lighter jack. 3. 1.5 A fuse in the Power Adapter is burned. 4. The Power Adapter is damaged. 	<ol style="list-style-type: none"> 1. Check if the cigarette lighter functions normally. 2. Clean the contact of the cigarette lighter jack and the Power Adapter. 3. Change the fuse. 4. If items 1-3 did not help, apply to a service center.
A caller does not hear you.	<ol style="list-style-type: none"> 1. The microphone is disconnected. 2. The microphone's cord is damaged. 	<ol style="list-style-type: none"> 1. Check the connection of the microphone and the microphone jack of the Handsfree unit. 2. Apply to a service center.
The device does not work. It is connected to the Car Radio through the adapter. The Car Radio works.	<ol style="list-style-type: none"> 1. No contact between the wires. 2. Car Radio wires have smaller diameter than necessary (with cross section area less than 0.75 mm²). 3. 1.5 A fuse in the Adapter is burned. 	<ol style="list-style-type: none"> 1. Check the contact in the connection points. 2. For the connection, use contact clips which correspond to the standard of your car or another suitable type of connection. 3. Change the fuse.
The device is connected to the Car Radio but does not mute it during a call.	The Car Radio Mute function needs additional settings to be activated.	Check your Car Radio user's manual and make the necessary settings.

TECHNICAL PARAMETERS

Car battery voltage

12.6 V (10.8 – 13.5)
with negative pole of GND.

Consumption current

In Talk mode – 0.8 A
In Stand-by mode – 50 m A

Fuse

1.5 A

SYSTEM CABLE SC2

- Red: +12B
- Black: GND
- Blue: ignition, ACC/IGN
- Brown: Mute function of Car Radio. In Talk mode voltage switches from +12 V to 0 V.

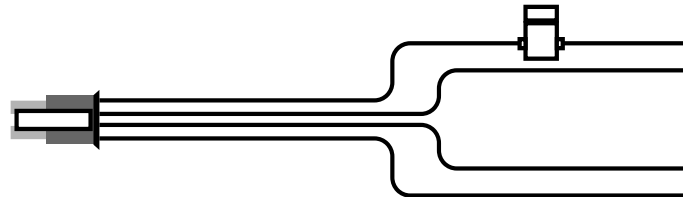

BLUETOOTH®

The *Bluetooth*® word mark and logos are owned by the Bluetooth SIG, Inc. and any use of such marks by TE-Group NV is under license. Other trademarks and trade names are those of their respective owners.

CARE AND TECHNICAL MAINTENANCE

The Blue Perfection is a product of superior design and craftsmanship and should be treated with care. The suggestions below will help you to fulfill any warranty obligations and to enjoy this product for many years.

- Keep the device and all its parts dry. Precipitation, humidity and all types of liquids or moistures can contain minerals that will corrode the electronic circuitry.
- Do not store the device in hot areas. High temperature can shorten the life of electronic devices, damage batteries and warp or melt certain plastics.
- Do not store the device in cold areas. When it warms up (to its normal temperature), moisture can form inside, which may damage the electronic circuitry boards.
- Do not attempt to open the device. Non-expert handling may damage it.
- Do not use harsh chemicals, cleaning solvents or strong detergents to clean the device.

Mr Handsfree wishes you a nice and safe trip!

FCC Statements

This device complies with part 15 of the FCC Rules. Operation is subject to the following two conditions: (1) This device may not cause harmful interference; and (2) This device must accept any interference received, including interference that may cause undesired operation.

WARNING:

Changes or modifications to this unit not expressly approved by the party responsible for compliance could void the user's authority to operate the equipment.

NOTE: This equipment has been tested and found to comply with the limits for a Class B digital device, pursuant to Part 15 of the FCC Rules. These limits are designed to provide reasonable protection against harmful interference in a residential installation. For body worn operation, this phone has been tested and meets the FCC RF exposure guidelines when used with the belt clip supplied or designated for this product. Use of other accessories may not ensure compliance with FCC RF exposure guidelines. This equipment generates, uses and can radiate radio frequency energy and, if not installed and used in accordance with the instructions, may cause harmful interference to radio communications. However, there is no guarantee that interference will not occur in a particular installation. If this equipment does cause harmful interference to radio or television reception, which can be determined by turning the equipment off and on, the user is encouraged to try to correct the interference by one or more of the following measures:

- Reorient or relocate the receiving antenna.
- Increase the separation between the equipment and receiver.
- Connect the equipment into an outlet on a circuit different from that to which the receiver is connected.
- Consult the dealer or an experienced radio/TV technician for help.