

Name : **1 Circuit 2-Way --- Touch,RF,RS485**

Model No. : LM-312P

Loading: LM-312P (AC-110V, Max.1,000W)

Wiring Diagram:

PLS check **Annex A** for the detail & install switches according to the site environment

Button/Circuit(s) Settings

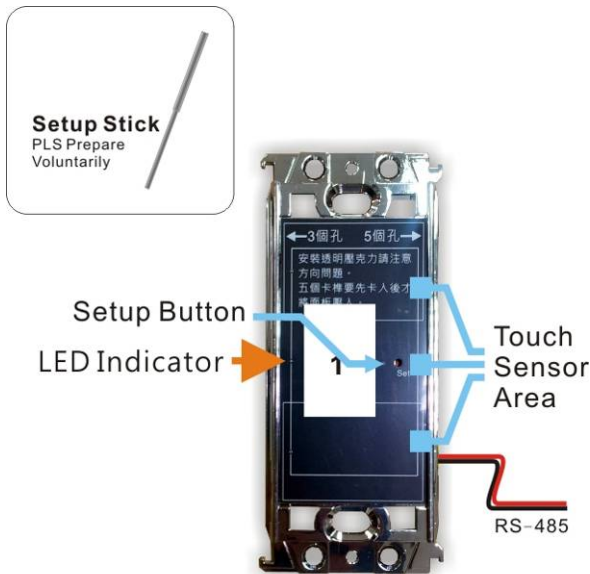

1. Please use [-] screwdriver (wound with tape) to dismantle the panel
2. Press & hold the Touch Sensor Area w/ your finger
3. **Take a stick to press the Setup Button (feel a “click”), when the red light on, let go your finger & setup stick.**
4. The red light on, means the switch is under the setting mode (window = 10 Sec.), if not, PLS repeat step (1) & (2).
5. Take a **remote** (ex. RC-07/RC-09), select **Zone (Zone 1,2 or 3)**, press **number** (position) then press **ON** to send the **RF** code to the switch.
6. When red led blinks then turns off, it means the setting is completed. PLS use the **remote** to control the switch **ON/OFF**, to confirm the setting.
7. PLS wait 30 sec. after installed the panel, till the sensor adapt the thickness of the panel, then you may touch the panel to switch ON/OFF the light.
8. **Control:** a.) **Touch sensor area to turn ON/OFF the light.** b.) **Remote:** select **Zone (Zone 1,2 or 3)**, press **number** (position) then press **ON/OFF**.
9. **This product can also set ID via RS-485 link, PLS follow step 1~4 & send code (Light No. [X] [ON]) by PC to the switch to complete the setting.**

Warning!

1. **This switch may co-work with a mechanical 2-way SW, PLS prepare voluntarily before installation.**
2. This series of SW can be install on wall or collected on the roof. Possesses 2-way cut & RS-485 communication functions
3. PLS use " Twisted pair + Isolation cloth " cable for RS-485 linkage
4. PLS use M type as doing the RS-485 connection, to ensure the communication signal stable.
5. The largest circuit of each of the RS-485 communication is limited to 32 sets of nodes, more than 32 sets of nodes or the distance is too long, please use RS-485 node connector.
6. Note: RS-485-type switches, are designed for specific engineering applications Please be sure to contact your dealer or the company's Technical Services Department before ordering.
7. Be sure to determine the correct wiring of the power supply polarity, wrong wiring will result in damage to the product and may endanger the safety
8. **Before setup, make sure the voltage loading of the circuit switch complies with local regulations. Improper usage of electric power and exceeding loading voltage will cause damage to the product.**
9. This product is a low-power RF wireless carrier communications transmission systems, in order to reduce environmental obstacles lead to remote insensitive, please try not to use the larger than the average residential space (details contact Dealer)

Annex A : Wiring Diagram

Powered From e²-LiVE 2-way

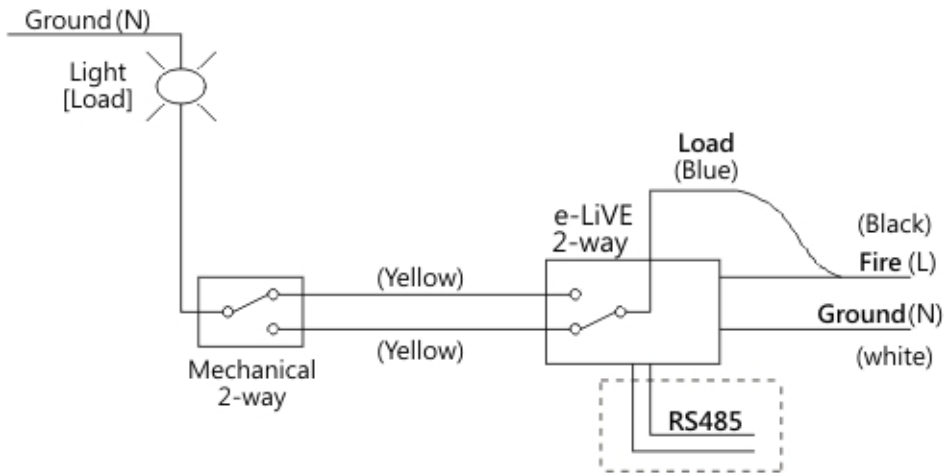

A-1 [Mechanical 2-way directly control the Light]

For LM,LC Series

4 Wires

FCC WARNING

This device complies with Part 15 of the FCC Rules. Operation is subject to the following two conditions:

- (1) This device may not cause harmful interference, and
- (2) this device must accept any interference received, including interference that may cause undesired operation.

NOTE 1: Any changes or modifications to this unit not expressly approved by the party responsible for compliance could void the user's authority to operate the equipment.