



Engine Operator's Manual

OV490EA

Four-Cycle Engine • Vertical Crankshaft • Air-Cooled

Table of Contents

IMPORTANT NOTICE! Safety Definitions.....	ii
I. General Safety Precautions	1
II. How to Get Service	3
III. Oil and Fuel Specifications.....	4
IV. Before Starting Your Engine.....	4
V. Starting Your Engine	6
VI. Stopping Your Engine and Short-Term Storage	10
VII. Maintenance	10
VIII. Transporting Your Engine.....	13
IX. Storing Your Engine	13
X. Preventing Forest, Brush and Grass Fires.....	15
XI. Maintenance Intervals.....	16
California & US EPA Emission Control Warranty Statement.....	20
Emission Control System Warranty	21
XII. Warranty Information.....	22

Visit our web site at www.TecumsehPower.com

- > Register Your Tecumseh Engine
- > Maintenance Tips
- > Parts Look-Up System
- > Great Tecumseh Apparel
- > Nearest Authorized Tecumseh Servicing Dealer Location

181-887-14
(English) 02/01/06

IMPORTANT NOTICE!

Safety Definitions

Statements in this manual preceded by the following words and graphics are of special significance:

 **WARNING**

Or

 **WARNING**

WARNING indicates a potentially hazardous situation which if NOT avoided, could result in death or serious injury.

NOTE

Refers to important information and is placed in italic type.

It is recommended that you take special notice of all items discussed on the next two pages and wear the appropriate safety equipment.

Before operating this engine *it is your responsibility* to read this Operator's Manual. Follow these basic rules for your personal safety:

- Keep this manual handy at all times for future reference.
- Read it carefully and familiarize yourself with operating, maintenance, components and safety instructions.

Notice Regarding Emissions

NOTE

Engines which are certified to comply with California and U.S. EPA emission regulations for SORE (Small Off Road Equipment), are certified to operate on regular unleaded gasoline, and may include the following emission control systems: (EM) Engine Modification and (TWC) Three-way Catalyst (if so equipped).

Tecumseh Contact Information

For engine adjustments, repairs or warranty service NOT covered in this manual, consult your local Authorized Tecumseh Servicing Dealer, call 1-800-558-5402, or go to www.TecumsehPower.com for additional information.

©Copyright 2004

Tecumseh Power Company

All Rights Reserved

I. General Safety Precautions

⚠ WARNING

Read equipment manufacturer's manual and this material thoroughly before using this engine. Failure to do so can result in serious injury or death. Consult your local Authorized Tecumseh Servicing Dealer, call 1-800-558-5402, or go to www.TecumsehPower.com for additional information.

A. Avoid Carbon Monoxide Poisoning

All engine exhaust contains carbon monoxide, a deadly gas. Breathing carbon monoxide can cause headaches, dizziness, drowsiness, nausea, confusion and eventually death.

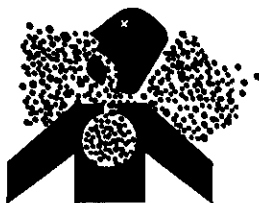

Carbon monoxide is a colorless, odorless, tasteless gas which may be present even if you DO NOT see or smell any engine exhaust. Deadly levels of carbon monoxide can collect rapidly and you can quickly be overcome and unable to save yourself. Also, deadly levels of carbon monoxide can linger for hours or days in enclosed or poorly-ventilated areas. If you experience any symptoms of carbon monoxide poisoning, leave the area immediately, get fresh air, and **SEEK MEDICAL TREATMENT**.

To prevent serious injury or death from carbon monoxide:

- NEVER run engine indoors. Even if you try to ventilate engine exhaust with fans or open windows and doors, carbon monoxide can rapidly reach dangerous levels.
- NEVER run engine in poorly-ventilated or partially enclosed areas such as barns, garages, basements, carports, under dwellings, or in pits.
- NEVER run engine outdoors where engine exhaust can be drawn into a building through openings such as windows and doors.

B. Avoid Gasoline Fires

Gasoline (fuel) vapors are highly flammable and can explode. Fuel vapors can spread and be ignited by a spark or flame many feet away from engine. To prevent injury or death from fuel fires, follow these instructions:



- NEVER store engine with fuel in fuel tank inside a building with potential sources of ignition such as hot water and space heaters, clothes dryers, electric motors, etc.
- NEVER remove fuel cap or add fuel when engine is running.
- NEVER start or operate the engine with the fuel fill cap removed.

- Allow engine to cool before refueling.
- NEVER fill fuel tank indoors. Fill fuel tank outdoors in a well-ventilated area.
- DO NOT smoke while refueling tank.
- Use only an approved red GASOLINE container to store and dispense fuel. Tecumseh recommends purchasing gasoline in containers with a capacity of 2.5 gallons or less. Small containers are easier to handle and help eliminate spillage during refueling.
- DO NOT pour fuel from engine or siphon fuel by mouth. To empty the fuel tank see "I. Draining Fuel" instructions on page 14.

C. Adult Supervision of Operation, Refueling and Maintenance

The manufacturer of the application may provide information about who is allowed to use this engine (see equipment manufacturer's manual). NOT everyone who is allowed to use this engine is capable of safely and responsibly operating, maintaining and/or fueling it. Tecumseh recommends the following:

- An adult should fuel this engine. NEVER allow children to refuel this engine. See "C. Filling Fuel Tank" instructions on page 5.
- An adult should perform maintenance on this engine. See "VII. Maintenance" instructions on page 10. Only allow children to perform maintenance if an adult has determined they are experienced and capable of such operation.
- An adult should start the engine. See "G. Avoid Accidental Starts" instructions on page 2. Only allow children to start the engine if an adult has determined they are experienced and capable of such operation.
- To avoid unsupervised operation of the engine, especially by children, NEVER leave it unattended when it is running.

D. Stay Away from Rotating Parts

NEVER operate the engine with an unguarded engine shaft.

The equipment manufacturer may attach a sprocket and chain or pulley and belt to the engine shaft. If these parts are NOT properly guarded, or if you are NOT sure whether they are properly guarded, DO NOT use your engine; contact the equipment manufacturer. Hands, feet, hair, jewelry, clothing, etc. can become entangled in rotating parts, leading to serious injury or death. To avoid serious injury or death, be sure the flywheel guard is in place.

See Figure 1, on page 2.



E. DO NOT Modify Engine

To avoid serious injury or death, DO NOT modify engine in any way. Tampering with the governor setting can lead to a runaway engine and cause it to operate at unsafe speeds. NEVER tamper with factory setting of engine governor.

⚠ WARNING

Use of this engine on fun-carts, go-karts, or mini-bikes can result in serious injury or death. Tecumseh manufactures the Power Sport line of engines for use in such applications. Consult your local Authorized Tecumseh Servicing Dealer, call 1-800-558-5402, or go to www.TecumsehPower.com for additional information.

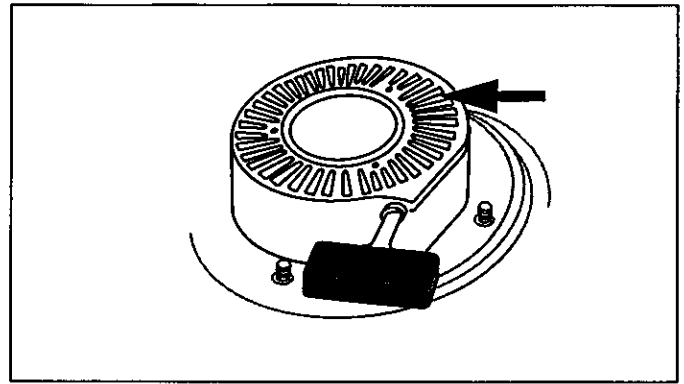

Figure 1. Typical Flywheel Guard Location

F. Avoid Burns and Fire from Hot Surfaces

The muffler and other engine parts become extremely hot during operation and remain hot after the engine has stopped.



- To avoid severe burns on contact, NEVER operate the engine without the muffler guard in place, and avoid hot areas of the engine.
- To reduce the risk of fire keep all materials that can burn, including grass and leaves, away from muffler and rest of engine. DO NOT operate, idle or park the engine application in long dry grass or other dry ground cover.

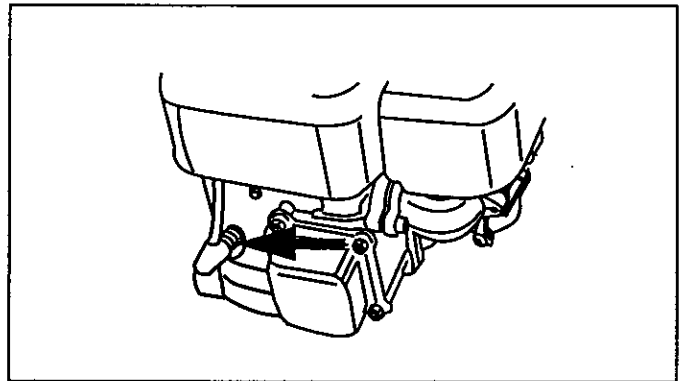

Figure 2. Typical Spark Plug Connection

G. Avoid Accidental Starts

To prevent accidental starting when working on equipment always:

- Carefully disconnect spark plug wire and keep it away from spark plug. See Figures 2 and 3.
 - Keep the disconnected spark plug wire securely away from metal parts where arcing could occur.
 - Carefully attach the spark plug wire to the grounding post, if provided.
- Disconnect battery at negative terminal first, if engine is equipped with an electric starter.
- Turn off all engine switches.
- Remove ignition key, if provided.

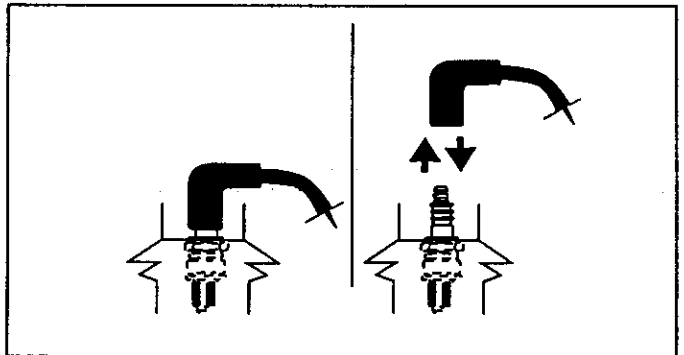

Figure 3. Disconnecting/Connecting Spark Plug

H. Use Hearing Protection

Engine noise may cause hearing damage. Always wear hearing protection when operating an engine.

II. How to Get Service

For engine adjustments, repairs or warranty service NOT covered in this manual, consult your local Authorized Tecumseh Servicing Dealer, call 1-800-558-5402, or go to www.TecumsehPower.com for additional information.

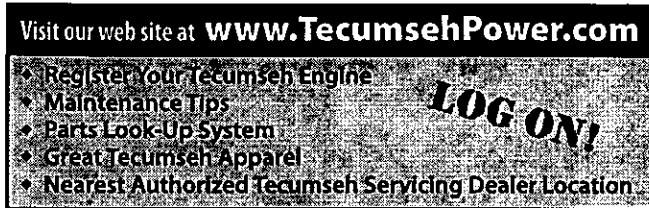

A. Engine Identification Decal

A sample engine identification decal (See Figure 4.) indicates the engine's model number, specification of engine and the date of manufacture (D.O.M.). Please look at the decal on your engine and fill in this information in the spaces provided for future reference.

The engine identification decal also includes engine life specifications for the emissions-related useful life period of your engine. This period relates to the emission compliance life as certified by EPA and/or CARB. To find the life period specification for your engine, please look on your engine's decal and find the letter enclosed by quotation marks between the words MODERATE and LIFE PERIOD. Match one of the following letters with the letter printed on your decal. For example, OV models are designated as "C" 250 hours, "B" 500 hours, and "A" 1000 hours.

B. Tecumseh Technician's Handbook

If you have a general understanding of internal combustion engines and wish to repair and service your engine and/or engine emission control systems yourself, a Technician's Handbook is available from your Authorized Tecumseh Servicing Dealer. See Figure 5. This handbook covers repairs and adjustments NOT covered within this Operator's Manual, and it is intended for individuals who have had adequate training, experience and who practice proper tool usage. Service procedures should be clearly understood and practiced when servicing Tecumseh Engines. Order as part no. 695244A for OV models.

Tecumseh manufactures and is responsible only for the engine used on this power equipment. If repair or service is needed for anything other than the engine, contact the service source recommended by the equipment manufacturer.

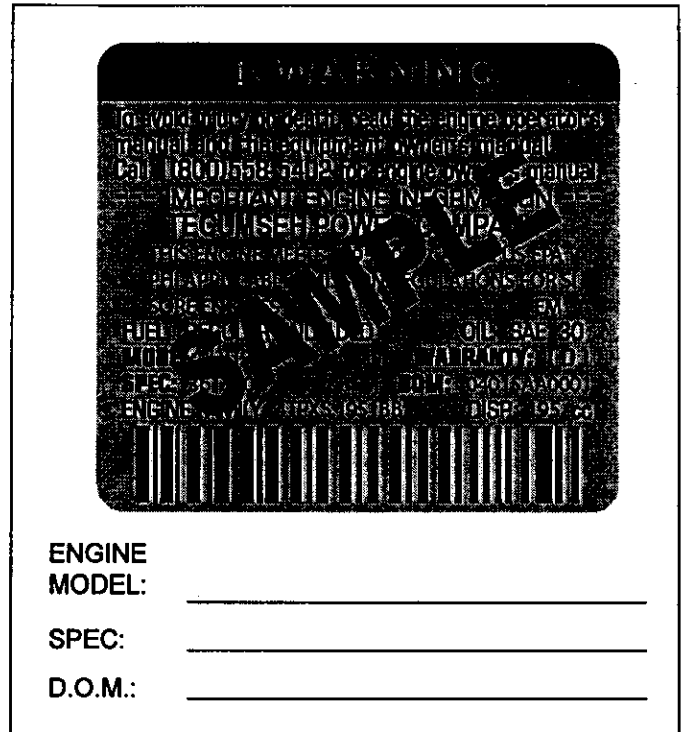

Figure 4. Engine Identification Decal

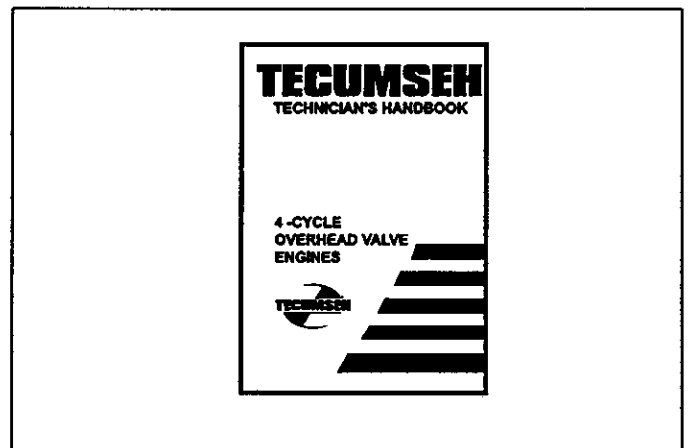

Figure 5. Technician's Handbook

III. Oil and Fuel Specifications

A. Oil

To operate engine you need to use a clean, high quality, detergent oil. For recommended engine oil, See Table 1.

NOTES

Be sure original container is marked A.P.I. Service "SL/SJ".

Using multigrade oil above 32°F (0°C) will increase oil consumption. SAE10W40 is NOT recommended.

The oil sump capacity (including oil filter) is 62 ounces or 3-7/8 U.S. Pints (1.83 liters).

The oil sump capacity (without oil filter) is 55 ounces or 3-7/16 U.S. Pints (1.62 liters).

Tecumseh special-formulated oils are available at your Authorized Tecumseh Servicing Dealer.

B. Fuel

Use unleaded regular, unleaded premium or reformulated automotive fuel only. You may use gasoline containing the following components identified in Table 2.

- DO NOT use leaded fuel.
- Fuel must be fresh and clean. NEVER use fuel left over from last season or stored for long periods.
- NEVER mix oil with fuel.
- DO NOT use fuel containing Methanol (Wood Alcohol).

IV. Before Starting Your Engine

A. Checking Oil Level

To avoid engine damage, it is important to:

- Check oil level before each use and every 5 operating hours when engine is warm. Check oil level more frequently during engine break-in.
- Keep oil level between "FULL" and "ADD" marks on dipstick. See Figure 6.
- Be sure oil fill cap/plug is tightened securely.

NOTES

DO NOT overfill oil filler. Doing so may result in oil carry-over to the air cleaner and equipment malfunction or damage.

DO NOT allow oil level to fall below the "ADD" mark on dipstick. Doing so may result in equipment malfunction or damage.

Contact your Authorized Tecumseh Servicing Dealer for Tecumseh Oil.

Table 1. Recommended Oil Usage

Table 2. Recommended Fuel

Fuel Component	Percentage
Ethanol	10%
Grain Alcohol ("Gasohol")	10%
MTBE (Methyl Tertiary Butyl Ether)	15%
ETBE (Ethyl Tertiary Butyl Ether)	15%

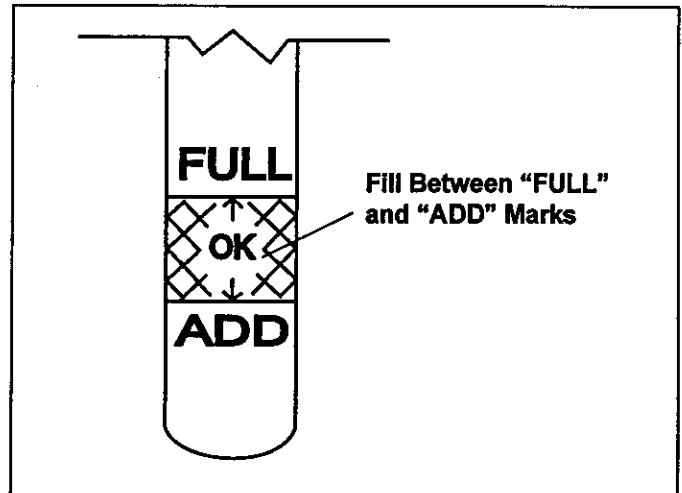

Figure 6. Engine Oil Level

B. Filling Oil Sump

1. Be sure engine is upright and level.
2. Unscrew oil fill cap from oil filler tube and wipe dipstick clean. See Figure 7.
3. Screw oil fill cap back into oil filler tube. Tighten securely.
4. Unscrew and remove oil fill cap from oil filler tube. Note oil level. If oil reading on dipstick is below "ADD" mark, slowly add oil to reach "FULL" level. See Figure 6, on page 4. Afterward, continue reading instructions below.
5. Screw oil fill cap back into oil filler tube. Tighten securely.
6. Wipe away any spilled oil.

C. Filling Fuel Tank

⚠ WARNING An adult should fuel this engine. NEVER allow children to refuel this engine. Gasoline (fuel) vapors are highly flammable and can explode. Fuel vapors can spread and be ignited by a spark or flame many feet away from engine. To prevent injury or death from fuel fires, follow these instructions:

1. Stop engine and allow it to cool before refueling.
2. Be sure engine is outdoors and in a well-ventilated area.
3. Clean area around fuel fill cap and remove fuel fill cap.
4. Using an approved red GASOLINE container, add fuel slowly, being careful to avoid spilling. DO NOT overfill fuel tank. Leave space in the tank to allow fuel to expand without overflowing.
5. Replace fuel fill cap securely and wipe up spilled fuel before starting engine. If fuel is spilled DO NOT start engine. Move machine away from area of spillage. Avoid creating any source of ignition until fuel vapors are gone.

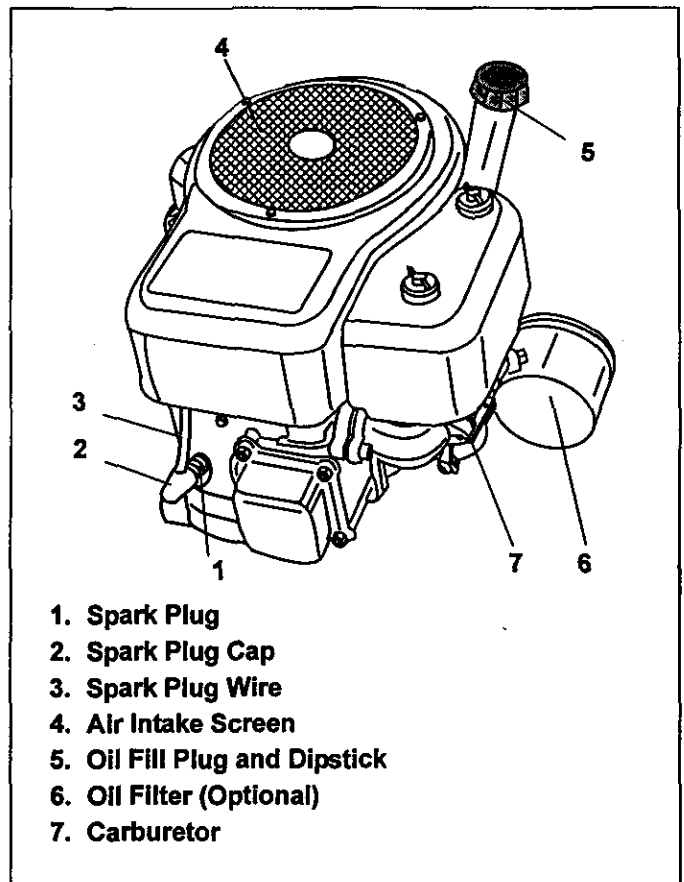

Figure 7. Engine with Oil Fill Dipstick

V. Starting Your Engine

⚠ WARNING

An adult should start the engine. Only allow children to start engine if an adult has determined they are experienced and capable of such operation.

⚠ WARNING

If you are unable to start this engine after following instructions in this manual, contact your Authorized Tecumseh Servicing Dealer. To avoid serious burn injuries or damage to your engine, DO NOT attempt to start or troubleshoot this engine in any other way. For example:

- DO NOT use starting fluid.
- DO NOT spray flammable vapors into carburetor or onto air cleaner.
- DO NOT put flammable liquids into carburetor or onto air cleaner.
- DO NOT operate engine or pull on starter rope with spark plug removed. Fuel can spray from spark plug hole and ignite.

This section contains starting instructions for electric and manual start engines. In order to locate the instructions that apply to your engine, first determine what type of starter you have. If you have an electric starter see "A. Engines with Electric Starters" instructions. If you have a manual recoil starter see "B. Engines with Recoil Starters" instructions on page 8.

A. Engines with Electric Starters

Only one of the following two sections will apply to your engine. See Table 3.

I. Combined Speed and Choke Control

1. To avoid carbon monoxide poisoning, be sure engine is outdoors in a well-ventilated area.
2. Move combined control to "CHOKE" or "START" position (see equipment manufacturer's instructions). See Figures 8 and 9.

NOTE

If restarting a warm engine after a short shutdown, move combined control to "FAST" instead of "CHOKE" or "START" position. See Figures 8 and 9.

3. Push starter button or turn ignition switch key (see equipment manufacturer's instructions) to start engine.

NOTES

DO NOT operate an electric starter for more than 5 seconds each attempt.

If engine fails to start after 3 attempts repeat steps 2 thru 3.

4. When engine starts:
 - a. Release starter button or ignition switch key.
 - b. Next, move combined control to "FAST" position.
 - c. Finally, move combined control to desired speed in "RUN" range.

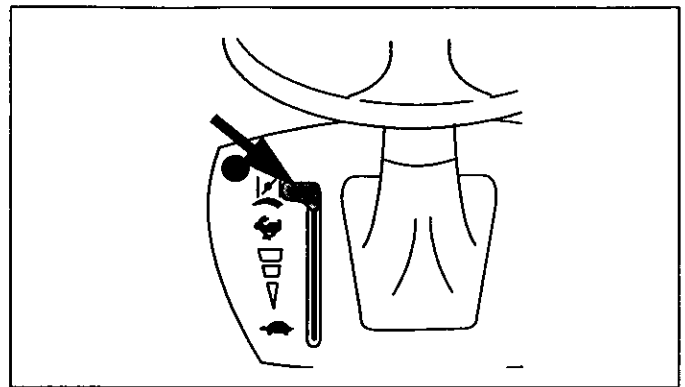

Figure 8. Combined Speed and Choke Control

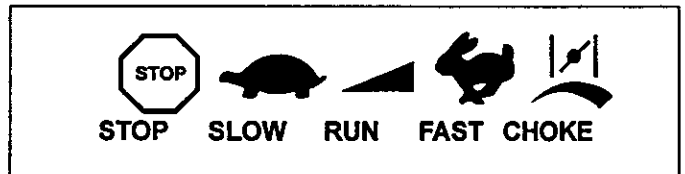

Figure 9. Typical Engine Symbols

Table 3. Engine Sections with Electric Starters

If your engine has	Go to
Combined Speed and Choke Control	Section A.I
Independent Speed and Choke Controls	Section A.II

NOTES

If engine starts, but falters when combined control is moved to "FAST" position:

- a. Momentarily move combined control back to "CHOKE" position.
- b. Next, move combined control to "FAST" position.
- c. Finally, move combined control to desired speed in "RUN" range.

If engine dies after combined control is moved to "FAST" position, repeat steps 2 thru 4 to restart engine.

5. If engine fires but does NOT continue to run, move combined control lever to "FAST" position and then start engine.
6. If engine fails to start after 3 attempts with combined control in "FAST" position, move combined control to "CHOKE" position and push button or turn key to start engine again.
7. If engine does NOT start after following steps 1 thru 6, contact your Authorized Tecumseh Servicing Dealer. DO NOT attempt to start or troubleshoot this engine in any other way.

II. Independent Speed and Choke Controls

1. To avoid carbon monoxide poisoning, be sure engine is outdoors in a well-ventilated area.
2. Move independent speed control to "FAST" position and set independent choke control to "FULL CHOKE" position (see equipment manufacturer's instructions). See Figures 9 thru 11.

NOTES

Generator and Water Pump applications may have the independent choke lever mounted on the engine. See Figure 12.

If restarting a warm engine after a short shutdown, move independent speed control to "FAST" position and move independent choke control to "NO CHOKE" position.

3. Push starter button or turn ignition switch key (see equipment manufacturer's instructions) to start engine.

NOTES

DO NOT operate an electric starter for more than 5 seconds each attempt.

If engine fails to start after 3 attempts repeat steps 2 thru 3.

4. When engine starts:
 - a. Release starter button or ignition switch key.
 - b. Next, move independent choke control to "1/2 CHOKE" position until engine runs smoothly.
 - c. Next, move independent choke control to "NO CHOKE" position.
5. Finally, move independent speed control to desired speed in "RUN" range.

NOTES

If engine starts, but falters when independent choke control is moved to "NO CHOKE" position:

- a. Momentarily move independent choke control back to "FULL CHOKE" position.
- b. Next, move independent choke control to "1/2 CHOKE" position until engine runs smoothly.
- c. Finally, move independent choke control to "NO CHOKE" position.

If engine dies after independent choke control is moved to "NO CHOKE" position, repeat steps 2 thru 5 to restart engine.

6. If engine fires but does NOT continue to run, move independent choke control lever to "NO CHOKE" position and start engine.
7. If engine fails to start after 3 attempts in the "NO CHOKE" position, move independent choke control to "FULL CHOKE" position and start engine.
8. If engine does NOT start after following steps 1 thru 7, contact your Authorized Tecumseh Servicing Dealer. DO NOT attempt to start or troubleshoot this engine in any other way

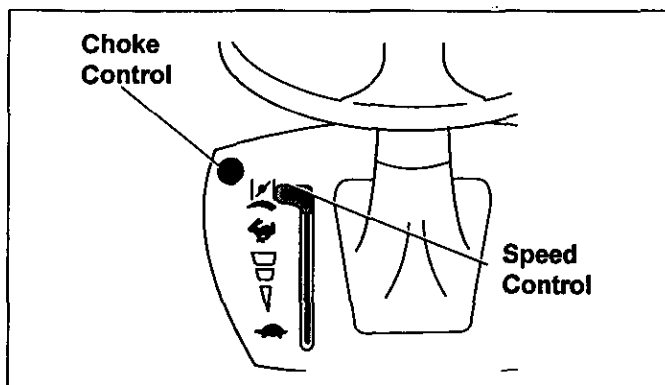

Figure 10. Independent Speed and Choke Controls

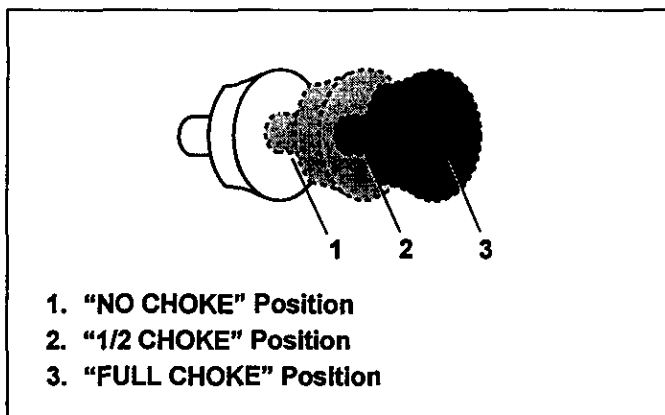

Figure 11. Choke Control Positions

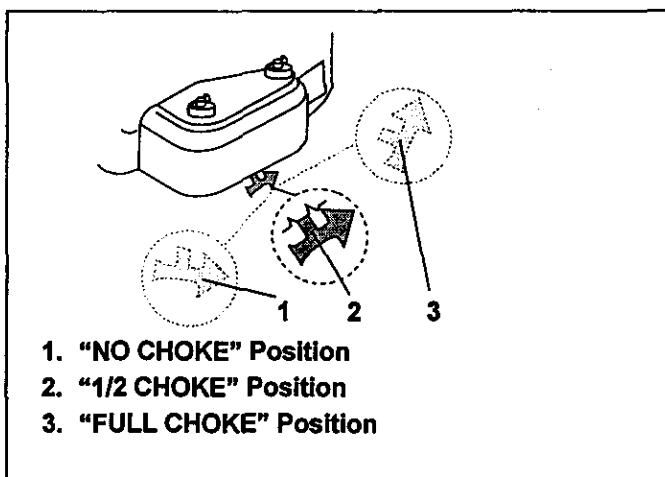

Figure 12. Engine Mounted Choke Lever

B. Engines with Recoil Starters

If you have an electric starter see "A. Engines with Electric Starters" instructions on page 6. Only one of the following two sections will apply to your engine. See Table 4.

Table 4. Engine Sections with Recoil Starters

If your engine has:	Go to:
Combined Speed and Choke Control	Section B.I
Independent Speed and Choke Controls	Section B.II

I. Combined Speed and Choke Control

- To avoid carbon monoxide poisoning, be sure engine is outdoors in a well-ventilated area.
- Move combined control to "CHOKE" or "START" position, if present (see equipment manufacturer's instructions). See Figures 13 and 14.

NOTE

If restarting a warm engine after a short shutdown, move combined control to "FAST" instead of "CHOKE" or "START" position. See Figures 13 and 14.

WARNING

When pulling starter rope, the rope can unexpectedly jerk back toward engine causing serious injury. To avoid this risk, carefully follow these instructions:

- Grasp starter cord handle. See Figure 15.
 - Pull rope out slowly until you feel drag.
 - Without allowing the rope to retract, continue pulling rope with one rapid full arm stroke.
 - Return rope *slowly* to original position.

NOTES

Following the instructions listed in the steps above avoids potential damage to the recoil mechanism.

If engine fails to start after 3 pulls repeat steps 2 thru 3.

- When engine starts:
 - Move combined control to "FAST" position.
 - Next, move combined control to desired speed in "RUN" range.

NOTES

If engine starts, but falters when combined control is moved to "FAST" position:

- Momentarily move combined control back to "CHOKE" position.

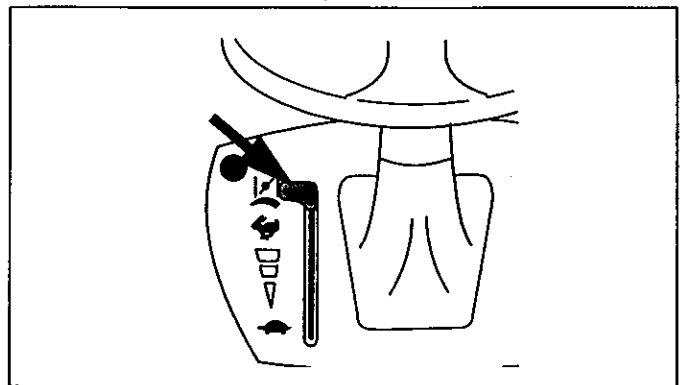

Figure 13. Combined Speed and Choke Control

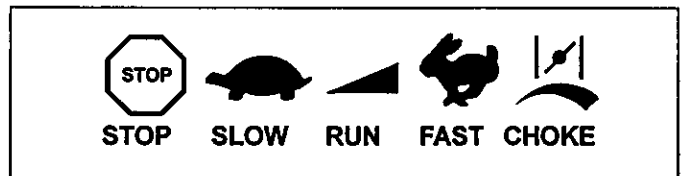

Figure 14. Typical Engine Symbols

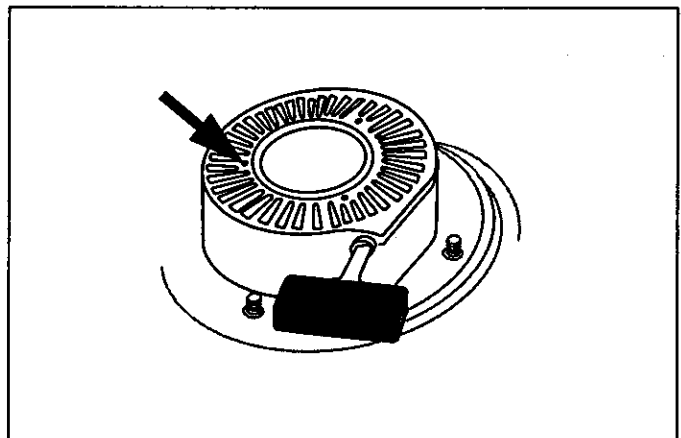

Figure 15. Recoil Starter

- Next, move combined control to "FAST" position.
- Finally, move combined control to desired speed in "RUN" range.

If engine dies after combined control is moved to "FAST" position, repeat steps 2 thru 4 to restart engine.

- If engine fires but does NOT continue to run, move combined control lever to "FAST" position and pull the starter rope.
- If engine fails to start after 3 attempts with combined control in the "FAST" position, move combined control to "FULL CHOKE" position and pull the starter rope again.
- If engine does NOT start after following steps 1 thru 6, contact your Authorized Tecumseh Servicing Dealer. DO NOT attempt to start or troubleshoot this engine in any other way.

II. Independent Speed and Choke Controls

1. To avoid carbon monoxide poisoning, be sure engine is outdoors in a well-ventilated area.
2. Move independent speed control to "FAST" position and set independent choke control to "FULL CHOKE" position (see equipment manufacturer's instructions). See Figures 14, 16, and 17.

NOTES

Generator and Water Pump applications may have the independent choke lever mounted on the engine. See Figure 18.

If restarting a warm engine after a short shutdown, move independent speed control to "FAST" position and move independent choke control to "NO CHOKE" position.

⚠ WARNING

When pulling starter rope, the rope can unexpectedly jerk back toward engine causing serious injury. To avoid this risk, carefully follow these instructions:

3. Grasp starter cord handle. See Figure 15.
 - a. Pull rope out slowly until you feel drag.
 - b. Without allowing the rope to retract, continue pulling rope with one rapid full arm stroke.
 - c. Return rope *slowly* to original position.

NOTE

Following the instructions listed in the steps above avoids potential damage to the recoil mechanism.

If engine fails to start after 3 pulls repeat steps 2 thru 3.

4. When engine starts:
 - a. Move independent choke control to "1/2 CHOKE" position until engine runs smoothly.
 - b. Next, move independent choke control to "NO CHOKE" position.
5. Finally, move independent speed control to desired speed in "RUN" range.

NOTES

If engine starts but falters when independent choke control is moved to "NO CHOKE" position:

- a. Momentarily move independent choke control back to "FULL CHOKE" position.
- b. Next, move independent choke control to "1/2 CHOKE" position until engine runs smoothly.
- c. Finally, move independent choke control to "NO CHOKE" position.

If engine dies after independent choke control is moved to "NO CHOKE" position repeat steps 2 thru 5 to restart engine.

6. If engine fires but does NOT continue to run, move independent choke control to "NO CHOKE" position and pull starter rope again.
7. If engine fails to start after 3 attempts in the "NO CHOKE" position, move independent choke control to "FULL CHOKE" position and pull starter rope again.

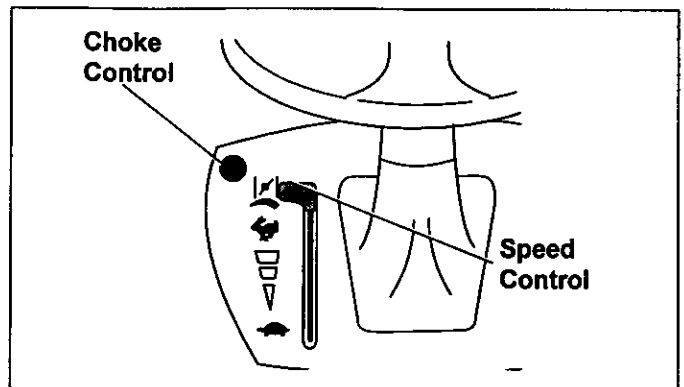

Figure 16. Independent Speed and Choke Controls

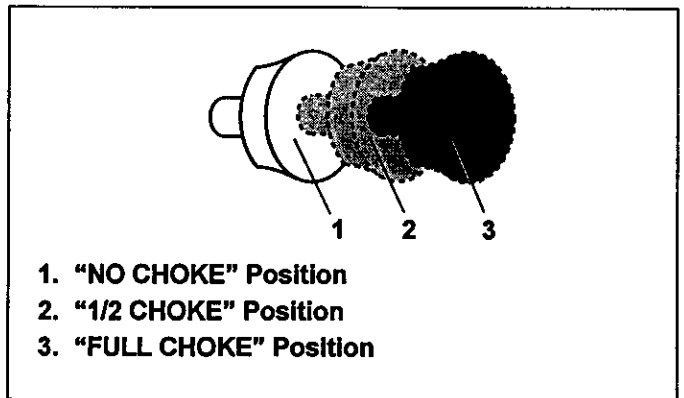

Figure 17. Choke Control Positions

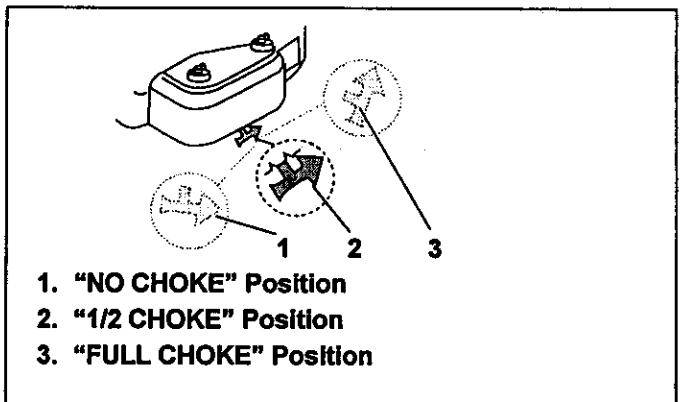

Figure 18. Engine Mounted Choke Lever

8. If engine does NOT start after following steps 1 thru 7, contact your Authorized Tecumseh Servicing Dealer. DO NOT attempt to start or troubleshoot this engine in any other way.

VI. Stopping Your Engine and Short-Term Storage

Stop engine according to equipment manufacturer's instructions.

⚠ WARNING

To avoid unsupervised operation of an engine, especially by children, NEVER leave it unattended when it is running. Always turn off the engine after use and remove ignition key, if provided.

⚠ WARNING

NEVER store the engine with fuel in the fuel tank inside a building with potential sources of ignition such as hot water and space heaters, clothes dryers, electric motors, etc.

VII. Maintenance

⚠ WARNING

An adult should perform maintenance on this engine. Only allow children to perform maintenance if an adult has determined they are experienced and capable of such operation.

⚠ WARNING

To prevent accidental starting when working on equipment, always:

- Carefully disconnect spark plug wire and keep it away from spark plug. See "G. Avoid Accidental Starts" instructions on page 2. Afterward, continue reading instructions below.
- Keep the disconnected spark plug wire securely away from metal parts where arcing could occur.
 - Carefully attach the spark plug wire to the grounding post, if provided.
 - Disconnect battery at negative terminal first, if engine is equipped with an electric starter.
- Turn off all engine switches.
- Remove ignition key, if provided.

A. Checking and Changing Oil

To avoid engine damage, it is important to:

- Check oil level before each use and every 5 operating hours when engine is warm. See "A. Checking Oil Level" instructions on page 4. Afterward, continue reading instructions below.
 - Change oil after first 2 operating hours and every 50 operating hours thereafter; more often if operated in extremely dusty or dirty conditions. Engine should still be warm but NOT hot from recent use.
1. Be sure you find the correct drain plug location, if present. (See equipment manufacturer's instructions). See Figure 19.
 2. Carefully disconnect spark plug wire and keep it away from spark plug. See "G. Avoid Accidental Starts" instructions on page 2. Afterward, continue reading instructions below.
 3. Be sure the gas cap is on and is tightened securely.
 4. Clean area around oil drain plug. See Figure 19.

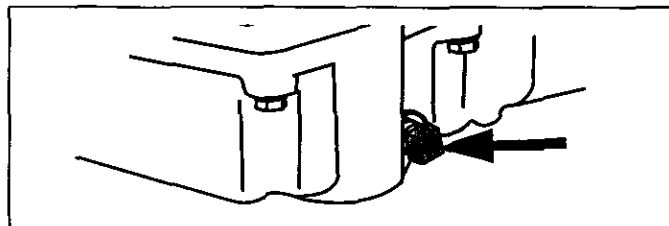

Figure 19. Oil Drain Plug Location

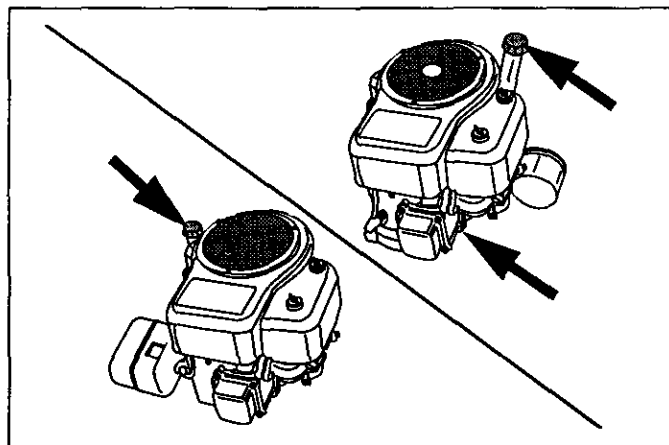

Figure 20. Oil Filler Locations

5. Place approved recyclable oil container under oil drain plug. (See equipment manufacturer's instructions).

NOTE

Used oil must be disposed of at a proper collection center.



6. Remove oil drain plug and drain oil into an approved container. See Figure 19.
7. Install oil drain plug and tighten securely.
8. Fill with recommended oil. See "III. Oil and Fuel Specifications" instructions on page 4. See "Table 1. Recommended Oil Usage" instructions on page 4. See Figure 20. Afterward, continue reading instructions below.
9. Wipe away any spilled oil.
10. Carefully disconnect spark plug wire from grounding post, if provided. See "G. Avoid Accidental Starts" instructions on page 2. See Figure 25, on page 15. Afterward, continue reading instructions below.
11. Carefully re-connect spark plug wire to spark plug. See Figure 26, on page 15. Afterward, continue reading instructions below.

NOTES

The oil filter if so equipped, should be changed every 100 operating hours or at least once a year.

The filter should be changed more often if the engine is operated in extremely dust or dirty conditions.

Changing the oil filter requires that additional oil be added to fill the filter.

Contact your Authorized Tecumseh Servicing Dealer for a Tecumseh Oil Filter.

B. Removing Debris from Engine

Before each use, remove the air cleaner cover. Discard grass clippings, dirt and debris from the following areas:

- Levers and Linkage
- Cooling Fins
- Air Intake Screen
- Air Inlet
- Guards

Removing debris will insure adequate cooling, correct engine speed and reduce the risk of fire. See Figure 21.

NOTES

Before removing air cleaner cover see "III. Filter Removal/Installation" instructions on page 12. Special care should be taken to prevent damage when removing air cleaner cover. See Figure 21. Afterward, continue reading instructions below.

DO NOT bend levers and linkage with fingers. See Figure 22.

1. Remove air cleaner cover and filters. See Figure 21.
2. Remove debris from air inlet, air cleaner cover and air intake screen.
3. Inspect filter(s) for discoloration or dirt accumulation. If either is present, see "I. Servicing Foam Pre-Filter" instructions on page 12 or see "II. Servicing Paper Filters" instructions on page 12. Afterward, continue reading instructions below.
4. Replace air cleaner cover and filters.

C. Spark Plug

Check spark plug yearly or every 100 operating hours.

1. Clean area around spark plug.
2. Remove and inspect spark plug.
3. Replace spark plug if porcelain is cracked or if electrodes are:
 - Pitted
 - Burned
 - Fouled with Deposits
4. Check electrode gap with wire feeler gauge and set gap to—.030 in. (0.76mm) if necessary. See Figure 23.
5. Install spark plug and tighten securely.

NOTE

A resistor spark plug must be used for replacement. Contact your Authorized Tecumseh Servicing Dealer for a Tecumseh Resistor Spark Plug.

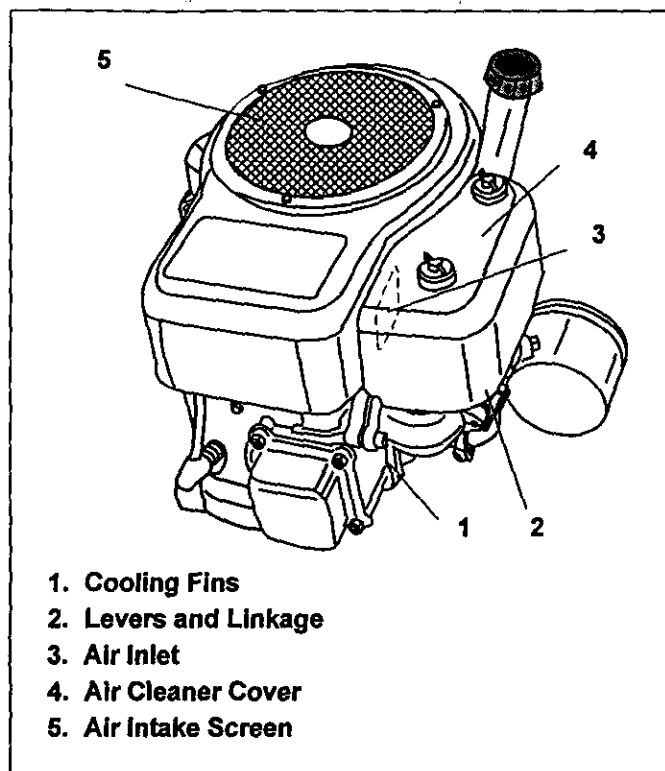

Figure 21. Debris Locations

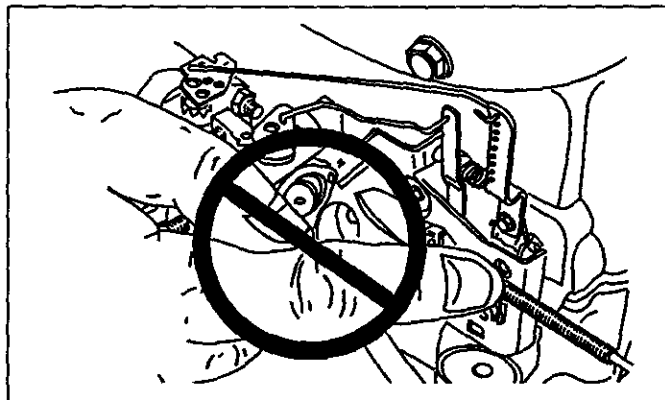

Figure 22. Linkage and Lever Bending

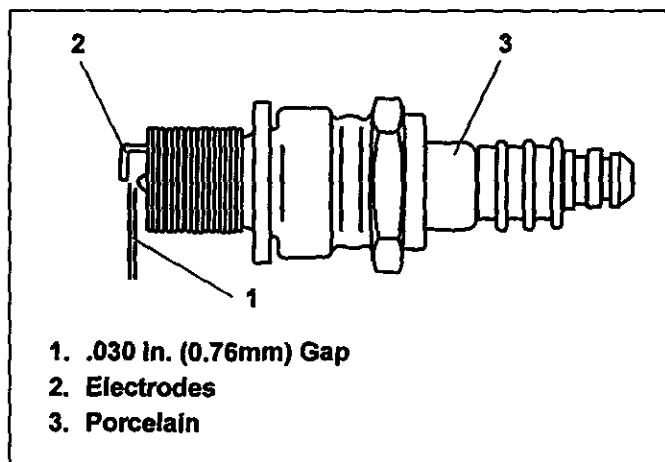

Figure 23. Spark Plug

D. Cleaning/Replacing Air Cleaner

Your engine has an air cleaner which helps prevent premature engine wear and failure. NEVER run engine without complete air cleaner installed on engine. Your air cleaner periodically needs to be cleaned or replaced.

NOTES

ALWAYS inspect filter(s) for discoloration or dirt accumulation. If either is present, see "I. Servicing Foam Pre-Filter" instructions and/or see "II. Servicing Paper Filters" instructions on this page.

Contact your Authorized Tecumseh Servicing Dealer for a Tecumseh Air Cleaner.

I. Servicing Foam Pre-Filter

Clean foam pre-filter every 3 months or every 25 operating hours. Clean daily if used in extremely dusty conditions. After removing the pre-filter, follow these cleaning instructions below:

1. Wash in warm water and detergent solution then press (DO NOT twist) until all dirt is removed.
2. Rinse thoroughly until water is clear.
3. Wrap in a clean cloth and press (DO NOT twist) until completely dry.

NOTE

DO NOT oil foam pre-filter.

4. Replace foam pre-filter onto paper filter.

II. Servicing Paper Filters

Paper filters cannot be cleaned and must be replaced once a year or every 100 operating hours; more often if used in extremely dusty conditions. Replacement filters are available at an Authorized Tecumseh Servicing Dealer.

NOTE

DO NOT put oil on or clean a paper filter.

III. Filter Removal/Installation

1. Remove wing nuts from air cleaner cover. See Figure 24.
2. Remove air cleaner cover while lifting upward then outward.
3. Remove fasteners.
4. Remove and inspect filter(s) for discoloration or dirt accumulation. If either is present, see "I. Servicing Foam Pre-Filter" instructions or see "II. Servicing Paper Filters" instructions on this page. Afterward, continue reading instructions below.
5. Clean inside of cover and body thoroughly.
6. Install paper filter (see equipment manufacturer's instructions).
7. Install fasteners.
8. Install foam pre-filter (see equipment manufacturer's instructions).

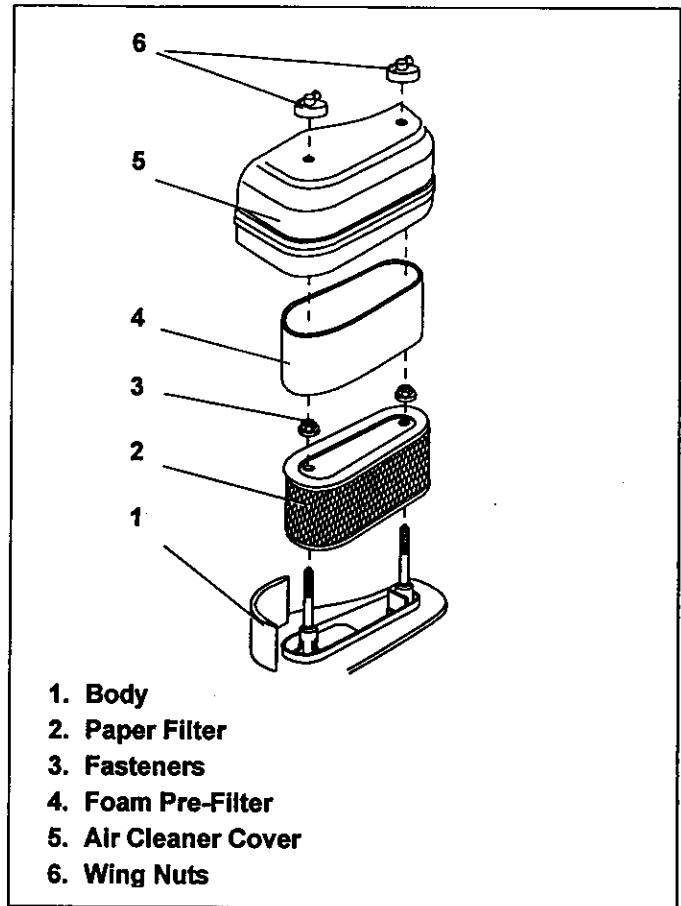

Figure 24. Air Cleaner Components

9. Install cover by pushing down onto body securely.
10. Install wings nuts and tighten securely.

E. Carburetor

If you think your carburetor needs adjusting, see your nearest Authorized Tecumseh Servicing Dealer. Engine performance should NOT be affected at altitudes up to 7,000 feet (2,134 meters). For operation at higher elevations, contact your Authorized Tecumseh Servicing Dealer.

F. Engine Speed

⚠ WARNING

To avoid serious injury or death, DO NOT modify engine in any way.

Tampering with the governor setting can lead to a runaway engine and cause it to operate at unsafe speeds. NEVER tamper with factory setting of engine governor.

Running the engine faster than the speed set at the factory can be dangerous and will VOID THE ENGINE WARRANTY.

G. Adjustments

DO NOT make any engine adjustments. Factory settings are satisfactory for most conditions. If adjustments are needed, contact your Authorized Tecumseh Servicing Dealer.

VIII. Transporting Your Engine

⚠ WARNING NEVER transport this engine inside another vehicle or in any enclosed space if there is any gasoline in the tank. Fuel vapor or spilled fuel may ignite.

⚠ WARNING If there is fuel in the fuel tank, close the fuel shut off valve, if equipped, and transport the engine upright in an open vehicle, such as an open trailer or open bed of a pickup truck.

If you DO NOT have an open vehicle and have to transport the engine upright in a closed vehicle, follow these steps for emptying the fuel tank before transporting:

1. Empty fuel tank by using a commercially available suction device designed for use with gasoline.

⚠ WARNING DO NOT pour fuel from engine or siphon fuel by mouth.

2. Drain fuel into an approved red GASOLINE container, being careful to avoid spilling.
3. Run the engine until remaining fuel is consumed.

⚠ WARNING NEVER leave the engine unattended when it is running and NEVER run engine in enclosed areas.

IX. Storing Your Engine

A. Short Term/Seasonal Storage

I. Clean Engine

Before servicing the engine remove the air cleaner cover and/or blower housing. Discard grass clippings, dirt and debris from the following areas:

- Cooling Fins
- Air Intake Screen
- Levers
- Linkage
- Guards
- Carburetor
- Head

Removing debris will facilitate adequate cooling, correct engine speed and reduce the risk of fire.

II. Fuel Storage

⚠ WARNING NEVER store engine with fuel in fuel tank inside a building with potential sources of ignition such as hot water and space heaters, clothes dryers, electric motors, etc. Failure to do so may result in an explosion and result in death or serious injury.

NOTES

If engine fuel stored in the gas tank and/or an approved gas container is to be unused without gasoline stabilizer for more than 15-30 days, prepare it for short term/seasonal storage. See "IV. Fuel Treatment" instructions on page 14. Afterward, continue reading instructions below.

If engine fuel is to be stored for more than one season, without gasoline stabilizer, it will gradually deteriorate. Also, if it is stored in the engine's gas tank without gasoline stabilizer it is likely that your carburetor will have gum deposits, a clogged fuel system and will void your warranty. Prepare the fuel for extended storage. See "B. Extended Storage" instructions on page 14. Afterward, continue reading instructions below.

If you operate the engine during all 4 seasons, it is NOT necessary to lubricate the cylinder bore.

III. Fuel System

To avoid stale gas and carburetor problems, treat the fuel system in the following method below:

NOTES

*Tecumseh recommends using **ULTRA-FRESH™** or Fuel Saver Plus Gasoline Stabilizer plus Fuel System Cleaner as an acceptable method of minimizing formation of fuel gum deposits during storage. This product is available from your Authorized Tecumseh Servicing Dealer.*

Always follow mix ratio found on stabilizer container. Failure to do so may result in equipment damage.

It is NOT necessary to drain stabilized gas from carburetor.

IV. Fuel Treatment

1. Add fuel stabilizer according to manufacturer's instructions.
2. Run engine at least 10 minutes after adding stabilizer to allow it to reach carburetor.

⚠ WARNING NEVER store the engine with fuel in the fuel tank inside a building with potential sources of ignition such as hot water and space heaters, clothes dryers, electric motors, etc.

NOTE

Instead of using a fuel preservative/stabilizer, you can empty the fuel tank as described under "I. Draining Fuel" instructions.

B. Extended Storage

I. Draining Fuel

NOTES

Clean debris from engine before draining fuel from carburetor. See "I. Clean Engine" instructions on page 13. Afterward, continue reading instructions below.

If you have prepared your fuel for short term storage it is NOT necessary to drain fuel that contains stabilizer from your carburetor. See "A. Short Term/Seasonal Storage" instructions on page 13. Afterward, continue reading instructions below.

⚠ WARNING To avoid severe injury or death, DO NOT pour fuel from engine or siphon fuel by mouth.

1. To prevent serious injury from fuel fires, empty fuel tank by running engine until it stops from lack of fuel. DO NOT attempt to pour fuel from engine.
2. Run the engine while waiting until the remaining fuel is consumed.

⚠ WARNING NEVER leave the engine unattended when it is running and NEVER run engine in enclosed areas.

3. Begin servicing the cylinder bore. See "II. Oil Cylinder Bore" instructions on page 15.

II. Oil Cylinder Bore

⚠ WARNING

When lubricating cylinder bore, fuel may spray from spark plug hole. To prevent serious injury from fuel fires, follow these instructions:

1. Carefully disconnect spark plug wire and keep it away from spark plug. See "G. Avoid Accidental Starts" instructions on page 2. See Figures 25 and 26. Afterward, continue reading instructions below.
 - Keep the disconnected spark plug wire securely away from metal parts where arcing could occur.
 - Carefully attach the spark plug wire to the grounding post, if provided.
 - Disconnect battery at negative terminal first, if engine is equipped with an electric starter.
 - Turn off all engine switches.
 - Remove ignition key, if provided.
2. Remove spark plug.
3. Squirt 1oz. (30ml) of clean engine oil into spark plug hole.
4. Cover spark plug hole with rag to prevent fuel from spraying from spark plug hole when starter rope is pulled.

NOTES

For engines equipped with recoil starters proceed to Step 5.

For engines equipped with electric starters proceed to Step 6.

5. Grasp starter cord handle and pull out slowly using a full arm stroke. Repeat once. (This will distribute oil throughout the cylinder to prevent corrosion during storage.)
6. Install spark plug.
7. Carefully disconnect spark plug wire from grounding post, if provided.
8. Carefully re-connect spark plug wire before attempting to start engine. See Figures 25 and 26.

III. Oil

Change oil if NOT changed within the last 3 months. See "A. Checking and Changing Oil" instructions on page 10.

IV. Battery

See equipment manufacturer's instructions for proper battery storage, if present.

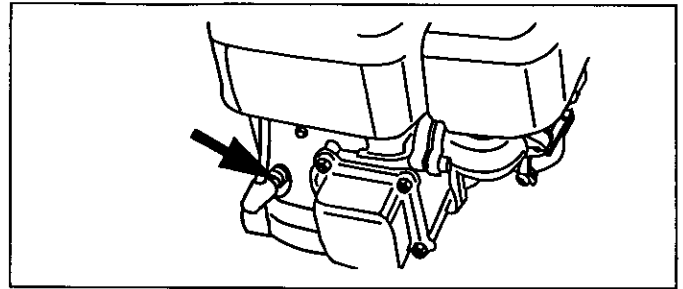

Figure 25. Typical Spark Plug Connection

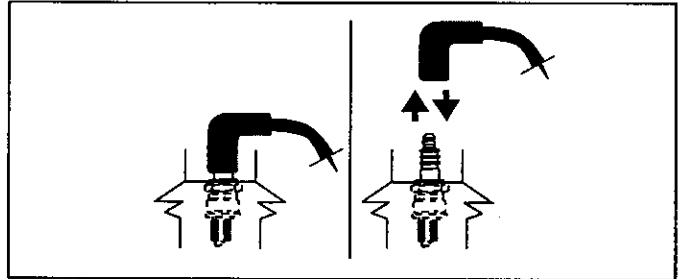

Figure 26. Disconnecting/Connecting Spark Plug

X. Preventing Forest, Brush and Grass Fires

Local, state and federal laws may require use of a spark arrester to prevent fires. For example, it is a violation of California Public Resources Code (section 4442) to use or operate engine on any forest-covered, brush-covered or unimproved grass-covered land unless engine is equipped with a spark arrester. Spark arrester must be maintained in effective working order by owner and/or operator.

To determine if your engine has a spark arrester, locate the muffler on your engine. For example, the muffler discharge will have a spark arrester cover that reads "Tecumseh Screen Type 36085".

If your engine does NOT have a spark arrester, you may purchase one from your Authorized Tecumseh Servicing Dealer. In some cases the muffler may need to be replaced to allow the spark arrester to be installed.

XI. Maintenance Intervals

Maintenance is one of the most important things that you can do to extend the life of your Tecumseh Engine. If you are unable to perform maintenance intervals yourself, consult your local Authorized Tecumseh Servicing Dealer, call 1-800-558-5402, or go to www.TecumsehPower.com for additional information.

ALWAYS promptly follow maintenance intervals listed in this manual. See Table 5.

Table 5. Maintenance Intervals

Procedure	Time
Change Oil	After First 2 hrs. When Engine is Warm
Check Oil Level	5 hrs. Or Before Each Use
Clean Cooling Fins	5 hrs. Or Before Each Use
Clean Foam Pre-Filter	25 hrs. Or 3 mos.
Change Oil	50 hrs. Or 3 mos.
Replace Paper and Oil Filter	100 hrs. Or Seasonally
Check Spark Plug	100 hrs. Or Seasonally
Replace Spark Plug	200 hrs. Or Seasonally

First Scheduled Maintenance

After First 2 Hours When Engine is Warm

1. Change Oil

Date _____ Owner/Dealer

CALIFORNIA & US EPA EMISSION CONTROL WARRANTY STATEMENT

The U. S. Environmental Protection Agency ("EPA"), the California Air Resources Board ("CARB") and Tecumseh Power Company are pleased to explain the Federal and California Emission Control Systems Warranty on your new small off-road engine. In California, new 1995 and later small off-road engines must be designed, built and equipped to meet the State's stringent anti-smog standards. In other states, new 1997 and later model year engines must be designed, built and equipped, at the time of sale, to meet the U.S. EPA regulations for small non-road engines. Tecumseh Power Company will warrant the emission control system on your small off-road engine for the periods of time listed below, provided there has been no abuse, neglect, unapproved modification, or improper maintenance of your small off-road engine.

Your emission control system may include parts such as the carburetor, air cleaner assembly, ignition system, exhaust system, crankcase breather assembly and, the evaporative control system. Also included may be the compression release system and other emission-related assemblies.

Where a warrantable condition exists, Tecumseh Power Company will repair your small off-road engine at no cost to you for diagnosis, parts and labor.

MANUFACTURER'S EMISSION CONTROL SYSTEM WARRANTY COVERAGE

Emission control systems on 1995 and later model year California small off-road engines are warranted for two years as hereinafter noted. In other states, 1997 and later model year engines are also warranted for two years. If, during such warranty period, any emission-related part on your engine is defective in materials or workmanship, the part will be repaired or replaced by Tecumseh Power Company.

OWNER'S WARRANTY RESPONSIBILITIES

As the small off-road engine owner, you are responsible for the performance of the required maintenance listed in your Operator's Manual, but Tecumseh Power Company will not deny warranty solely due to the lack of receipts or for your failure to provide written evidence of the performance of all scheduled maintenance.

As the small off-road engine owner, you should, however, be aware that Tecumseh Power Company may deny you warranty coverage if your small off-road engine or a part thereof has failed due to abuse, neglect, improper maintenance or unapproved modifications.

You are responsible for presenting your small off-road engine to a Tecumseh Authorized Service Outlet (any Tecumseh Registered Service Dealer, Tecumseh Authorized Service Distributor or Tecumseh Central Warehouse Distributor) as soon as a problem exists. The warranty repairs should be completed in a reasonable amount of time, not to exceed 30 days.

Warranty service can be arranged by contacting either an Authorized Tecumseh Servicing Dealer and/or Tecumseh Power Company, c/o Service Manager, 900 North Street, Grafton, WI 53024-1499. Telephone 1-262-377-2700 [or in USA/Canada call 1-800-558-5402].

IMPORTANT NOTE

This warranty statement explains your rights and obligations under the Emission Control System Warranty ("ECS Warranty") which is provided to you by Tecumseh Power Company pursuant to California law. Tecumseh Power Company also provides to original purchasers of new Tecumseh Power Company engines the Tecumseh Power Company Limited Warranties for New Tecumseh Engines and Electronic Ignition Modules. The Tecumseh Power Company Limited Warranties for New Tecumseh Engines and Electronic Ignition Modules ("Tecumseh Power Company Warranty") are located on the back cover of the Operator's Manual, enclosed with all new Tecumseh Power Company engines. The ECS Warranty applies only to the emission control system of your new engine. To the extent that there is any conflict in terms between the ECS Warranty and the Tecumseh Power Company Warranty, the ECS Warranty shall apply except in any circumstances in which the Tecumseh Power Company Warranty may provide a longer warranty period. Both the ECS Warranty and the Tecumseh Power Company Warranty describe important rights and obligations with respect to your new engine.

Warranty service can only be performed by a Tecumseh Power Company Authorized Servicing Dealer. At the time of requesting warranty service, evidence must be presented of the date of sale to the original purchaser. The purchaser shall pay any charges for making service calls and/or for transporting the products to and from the place where the inspection and/or warranty work is performed. The purchaser shall be responsible for any damage or loss incurred in connection with the transportation of any engine or any part(s) thereof submitted for inspection and/or warranty work.

If you have any questions regarding your warranty rights and responsibilities, you should contact Tecumseh Power Company at 1-262-377-2700 or in USA/Canada call 1-800-558-5402.

Revised July, 2005

IMPORTANT!

The emission Regulations may be different for your country. The emissions Control Warranty Statement is only applicable to engines with an emissions compliance statement and decal that references "Emissions Regulations".

EMISSION CONTROL SYSTEM WARRANTY

Emission Control System Warranty ("ECS Warranty") for 1995 and later model year California small off-road engines (for other states, 1997 and later model year engines):

A. APPLICABILITY: This warranty shall apply to 1995 and later model year California small off-road engines (for other states, 1997 and later model year engines). The ECS Warranty Period shall begin on the date the new engine or equipment is delivered to its original, end-use purchaser, and shall continue for 24 consecutive months thereafter.

B. GENERAL EMISSIONS WARRANTY COVERAGE:

Tecumseh Power Company warrants to the original, end-use purchaser of the new engine or equipment and to each subsequent purchaser that each of its small off-road engines is:

1. Designed, built and equipped so as to conform with all applicable regulations adopted by the Air Resources Board pursuant to its authority in Chapters 1 and 2, Part 5, Division 26 of the Health and Safety Code, and
2. Free from defects in materials and workmanship which, at any time during the ECS Warranty Period, will cause a warranted emissions-related part to fail to be identical in all material respects to the part as described in the engine manufacturer's application for certification.

C. THE ECS WARRANTY ONLY PERTAINS TO EMISSION-RELATED PARTS ON YOUR ENGINE AS FOLLOWS:

1. Any warranted, emissions-related parts which are not scheduled for replacement as required maintenance in the Operator's Manual shall be warranted for the ECS Warranty Period. If any such part fails during the ECS Warranty Period, it shall be repaired or replaced by Tecumseh Power Company according to Subsection 4 below. Any such part repaired or replaced under the ECS Warranty shall be warranted for any remainder of the ECS Warranty Period.
2. Any warranted, emissions-related part which is scheduled only for regular inspection as specified in the Operator's Manual shall be warranted for the ECS Warranty Period. A statement in such written instructions to the effect of "repair or replace as necessary", shall not reduce the ECS Warranty Period. Any such part repaired or replaced under the ECS Warranty shall be warranted for the remainder of the ECS Warranty Period.
3. Any warranted, emissions-related part which is scheduled for replacement as required maintenance in the Operator's Manual, shall be warranted for the period of time prior to the first scheduled replacement point for that part. If the part fails prior to the first scheduled replacement, the part shall be repaired or replaced by Tecumseh Power Company according to Subsection 4 below. Any such emissions-related part repaired or replaced under the ECS Warranty, shall be warranted for the remainder of the ECS Warranty Period prior to the first scheduled replacement point for such emissions-related part.
4. Repair or replacement of any warranted, emissions-related part under this ECS Warranty shall be performed at no charge to the owner at a Tecumseh Authorized Service Outlet.

5. The owner shall not be charged for diagnostic labor which leads to the determination that a part covered by the ECS Warranty is in fact defective, provided that such diagnostic work is performed at a Tecumseh Authorized Service Outlet.
6. Tecumseh Power Company shall be liable for damages to other original engine components or approved modifications proximately caused by a failure under warranty of an emission-related part covered by the ECS Warranty.
7. Throughout the ECS Warranty Period, Tecumseh Power Company shall maintain a supply of warranted emission-related parts sufficient to meet the expected demand for such emission-related parts.
8. Any Tecumseh Power Company authorized and approved emission-related replacement part may be used in the performance of any ECS Warranty maintenance or repair and will be provided without charge to the owner. Such use shall not reduce Tecumseh Power Company ECS Warranty obligations.
9. Unapproved add-on or modified parts may not be used to modify or repair a Tecumseh Power Company engine. Such use voids this ECS Warranty and shall be sufficient grounds for disallowing an ECS Warranty claim. Tecumseh Power Company shall not be liable hereunder for failures of any warranted parts of a Tecumseh Power Company engine caused by the use of such an unapproved add-on or modified part.

EMISSION-RELATED PARTS INCLUDE THE FOLLOWING:

1. Carburetor Assembly including internal components:
 - a) Carburetor gaskets
 - b) Intake pipe
2. Air Cleaner Assembly including components:
 - a) Air filter element
3. Ignition System including components:
 - a) Spark plug
 - b) Ignition module
 - c) Flywheel assembly
4. Exhaust System including components:
 - a) Catalytic muffler (*if so equipped*)
 - b) Muffler gasket (*if so equipped*)
 - c) Exhaust manifold (*if so equipped*)
5. Crankcase Breather Assembly including components
 - a) Breather connection tube
6. Evaporative Control System including components:
 - a) Fuel line(s)
 - b) Fuel filter
 - c) Canister (*if so equipped*)
 - d) Fuel tank (*if so equipped*)
 - e) Fuel fill cap (*if so equipped*)

Revised July, 2005

IMPORTANT!

The emission Regulations may be different for your country. The emissions Control Warranty Statement is only applicable to engines with an emissions compliance statement and decal that references "Emissions Regulations".

XII. Warranty Information

LIMITED WARRANTY FOR NEW TECUMSEH ENGINES AND ELECTRONIC IGNITION MODULES

For the time period shown below from the date of purchase and subject to the exceptions and limitations described herein, Tecumseh Power Company will, at its option as the exclusive remedy, either repair or replace for the original purchaser, free of charge, any part of any new Tecumseh engine which is found, upon examination by any Authorized Tecumseh Servicing Outlet or by Tecumseh's factory in Grafton, Wisconsin, to be DEFECTIVE IN MATERIAL AND/OR WORKMANSHIP. This Limited Warranty DOES NOT COVER (i) any Tecumseh engine or part(s) thereof used to power any vehicle in competitive racing and/or used on any commercial or rental track, or (ii) defects or damage caused by alterations or modifications of new Tecumseh engines or parts or by normal wear, accidents, improper maintenance, improper use or abuse of the product, or failure to follow the instructions contained in an Instruction Manual for the operation of the new Tecumseh engine or part. The cost of normal maintenance or replacement of service items which are not defective shall be paid for by the original purchaser. At the time warranty service is requested, evidence must be presented of the date of purchase by the original purchaser. Any charge for making service calls and/or for transporting any engine or part(s) thereof to and from the place where the inspection and/or warranty work is performed is payable solely by the purchaser. The purchaser is responsible for any damage or loss incurred in connection with the transportation of any engine or part(s) thereof submitted for inspection and/or warranty work. **WARRANTY SERVICE CAN ONLY BE PERFORMED BY A TECUMSEH AUTHORIZED SERVICE OUTLET.** Warranty service can be arranged by contacting a Tecumseh Authorized Service Outlet (any Tecumseh Registered Service Dealer, Tecumseh Authorized Service Distributor, or Tecumseh Central Warehouse Distributor) or by contacting Tecumseh c/o Service Manager, 900 North Street, Grafton, Wisconsin 53024-1499.

Warranty	"CONSUMER USE" (4)		"COMMERCIAL USE" (5)	
	Within	Outside	Within	Outside
Category	U.S.A. and Canada	U.S.A. and Canada	U.S.A. and Canada	U.S.A. and Canada
(A)	90 Day	90 Day ⁽¹⁾	No Warranty	No Warranty
(B)	1 Year	1 Year ⁽¹⁾	1 Year	1 Year
(C)	2 Years	1 Year ⁽¹⁾	1 Year	1 Year
(D)	2 Years	2 Years ⁽²⁾	1 Year	1 Year
(E)	2 Years	2 Years	1 Year	1 Year
(H)	2 'n 10 ⁽³⁾	2 'n 10 ⁽³⁾	1 Year	1 Year
(K)	2 'n 10 ⁽³⁾	2 'n 10 ⁽³⁾	2 'n 10 ⁽³⁾	1 Year
(M) ⁽⁷⁾	3 Years	3 Years	1 Year	1 Year

- (1) 2 years for Member States of the European Union. Consumers may have additional legal rights not affected by the terms of this warranty pursuant to EU Directive 1999/44/EC and the national legislation of certain Member States of the European Union.
- (2) 1 year for Australian/New Zealand for rotary mower engines.
- (3) 2 years on engine and 10 years (the first 5 years covering parts and labor only; the second 5 years covering parts only) on electronic ignition.
- (4) For purposes of this warranty policy, "consumer use" shall mean consumer's personal, residential, household use by the original retail purchaser.
- (5) For purposes of this warranty policy, "commercial use" shall mean all other uses, including use for commercial, income producing, or rental purposes.
- (6) The engine warranty category of your engine can be determined by review of the engine model number on the "Important Engine Information" decal. One letter in the engine model number will be surrounded by parenthesis (A), (B), (C), (D), (E), (H) (K) or (M) and that letter is your engine warranty category designation.
- (7) Qualification for three (3) year consumer use warranty under engine warranty category (M) may be determined by notation of an (M) designation on the "Important Engine Information" decal located on the engine housing or an addendum decal affixed adjacent thereto.

THIS EXPRESS WARRANTY IS SUPPLEMENTED BY THE TECUMSEH CALIFORNIA EMISSION CONTROL WARRANTY STATEMENT, if any.

THIS EXPRESS WARRANTY IS IN LIEU OF ALL OTHER EXPRESS WARRANTIES. Neither Tecumseh nor any of its affiliates makes any warranties, representations, or promises, written or oral, as to the quality of the engine or any of its parts, other than as set forth herein. ANY IMPLIED WARRANTY OF MARKETABILITY, MERCHANTABILITY, OR FITNESS FOR A PARTICULAR PURPOSE, TO THE EXTENT THAT EITHER MAY APPLY TO ANY TECUMSEH ENGINE OR PART(S) THEREOF, SHALL BE LIMITED IN DURATION TO THE PERIODS OF THE EXPRESS WARRANTIES SHOWN IN THE WARRANTY PERIOD CHART ABOVE AND TO THE EXTENT PERMITTED BY LAW ANY AND ALL IMPLIED WARRANTIES ARE EXCLUDED. IN NO EVENT WILL TECUMSEH BE LIABLE FOR ANY INDIRECT, INCIDENTAL, CONSEQUENTIAL OR SPECIAL DAMAGES AND/OR EXPENSES, INCLUDING, BUT NOT LIMITED TO, ANY LOSS OF TIME, INCONVENIENCE, LOSS OF UNIT USE OR ANY COST OR EXPENSE OF SUBSTITUTE UNITS DURING PERIODS OF MALFUNCTION OR NON-USE. Some states do not allow limitations on how long an implied warranty lasts or the exclusion or limitation of incidental or consequential damages, so the above limitation(s) or exclusion(s) may not apply to you. This Limited Warranty gives you specific legal rights and you may also have other legal rights which vary from state-to-state.

Tecumseh neither assumes nor authorizes any other person, natural or corporate, to assume for Tecumseh any other obligations or liabilities in connection with or with respect to any Tecumseh product or parts. The seller or dealer of a Tecumseh Product or part has no authority, whatsoever, to make any representations or promises on behalf of Tecumseh or to modify the terms or limitations of Tecumseh's warranty in any way.

Revised January, 2004

WARNING CALIFORNIA PROPOSITION 65

The engine exhaust from this product contains chemicals known to the State of California to cause cancer, birth defects or other reproductive harm.



Tecumseh Power Company • Grafton, Wisconsin 53024-1499 • USA
Telephone: 1-800-558-5402

Visit us at: www.TecumsehPower.com

181-887-14
(English) 02/01/06