



## Quick Installation Guide

Smart Wi-Fi Light Switch 3-Way  
SS6

### Package contents

- Smart Wi-Fi Light Switch 3-Way x1
- Wall plate x1
- Wire label x1
- Wire nut x5
- Screw x2
- Quick installation guide x1

For product or function details, please go to [www.tendacn.com](http://www.tendacn.com) to download the user guide.

### Technical Support

Shenzhen Tenda Technology Co., Ltd.  
6-8 Floor, Tower E3, NO.1001, Zhongnanyuan Road,  
Nanshan District, Shenzhen, China. 518052

USA hotline: 1-800-570-5892

Toll Free: 7x 24 hours

Canada hotline: 1-888-998-8966

Toll Free: Mon - Fri 9 am - 6 pm PST

Hong Kong hotline: 00852-81931998

Global hotline: +86 755-2765 7180 (China Time Zone)

Website: [www.tendacn.com](http://www.tendacn.com)

E-mail: [support@tenda.com.cn](mailto:support@tenda.com.cn)

### Copyright

© 2020 Shenzhen Tenda Technology Co., Ltd. All rights reserved.  
Tenda is a registered trademark legally held by Shenzhen Tenda Technology Co., Ltd. Other brand and product names mentioned herein are trademarks or registered trademarks of their respective holders. Specifications are subject to change without notice.

## Get to know Smart Wi-Fi Switch

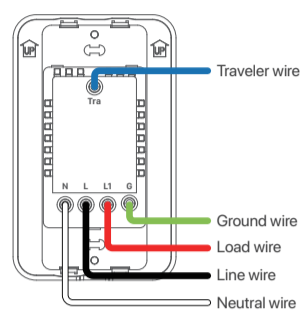
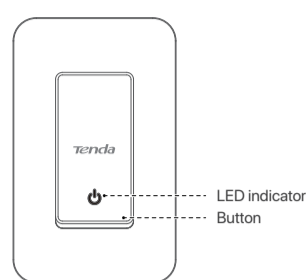

LED Indicator	<b>Blinking orange:</b> Initializing and starting.
	<b>Blinking blue:</b> Connecting to a 2.4 GHz Wi-Fi network.
	<b>Solid blue:</b> Connected to a 2.4 GHz Wi-Fi network and switched on.
	<b>Solid orange:</b> Disconnected from a 2.4 GHz Wi-Fi network.
Button	<b>Dark blue:</b> Switched off.
	<b>On/Off:</b> Press the button once.
	<b>Reset:</b> Hold down the button for about 5 seconds to 8 seconds and release it when the LED indicator blinks orange. The Smart Wi-Fi Switch is reset successfully. Follow this guide to configure it again.

## Install the device



- Note:**
- A certain amount of electrical knowledge is required to install a Smart Wi-Fi Switch. If you are not comfortable with basic electrical wiring, please consult an electrician.
  - You may need a screwdriver, pliers, wire strippers and a voltage detector for the installation. Please prepare them in advance.
  - This product is for indoor dry location use only.
  - If you do not have neutral wire at home, the Smart Wi-Fi Switch is not applicable.
  - This Smart Wi-Fi Switch 3-way can be used with our Smart Wi-Fi Switch 3-Way, or with ordinary non-smart 3-way switch.

### Step 1: TURN OFF THE POWER

- Turn off the circuit breaker of your light switch.
- Make sure power is off by turning your light switch on and off a few times.

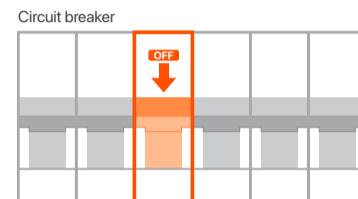

### Step 2: Remove the old switch

- Remove the screws that secure your old wall plate.

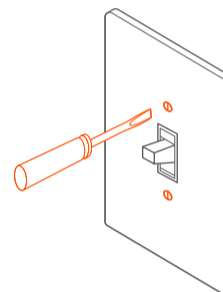

- Verify that no electricity is going through the wire using the voltage detector.

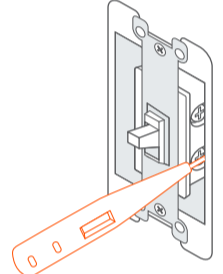

- Remove the screws securing your old switch to the wall box.

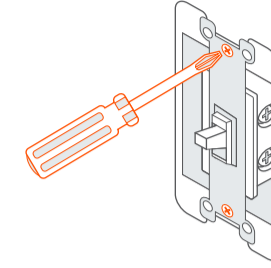

- Pull the switch out gently but do not disconnect the wires yet.

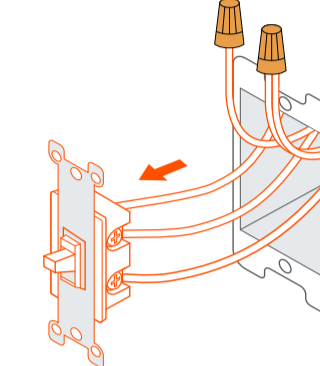

- In the wall box, identify the **Neutral, Ground, Line, Load** (if any) and **Traveler** wire, then label them.

- Tips:**  
If your line and load wire are both black, refer to **Q4 in FAQ**.

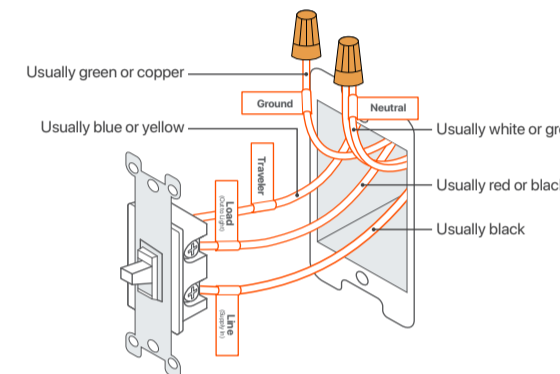

- Disconnect all wires from the old switch, and make sure not to remove any of the wire labels.

- Tips:**  
If you want to replace both old 3-way switches, please repeat **Step 1** and **Step 2** to remove the other old switch.

## Step 3: Install the Smart Wi-Fi Switch

- Match the wires of the Smart Wi-Fi Switch with those in the wall box according to the wire labels, and secure them using the wire nuts.

- Tips:**  
If you want to replace only one old 3-way switch, please replace the old 3-way switch installed in the wall box with load wire.

- In the wall box with Load wire

Secure the **Neutral wire, Ground wire, Line wire, Load wires** and **Traveler wire** from Smart Wi-Fi Switch and the wall box correspondingly.

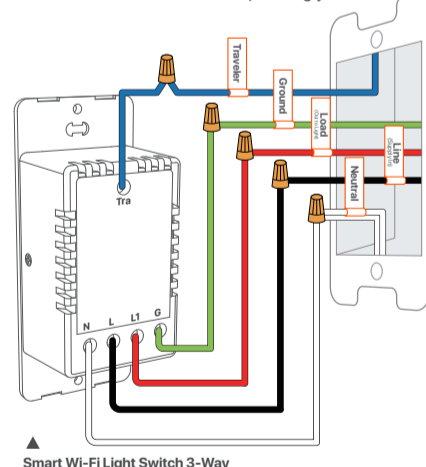

- In the wall box without Load wire

Secure the **Neutral wire, Ground wire and Line wire** from Smart Wi-Fi Switch and the wall box correspondingly.

Secure the **Load wire** from the Smart Wi-Fi Switch to the **Traveler wire** coming from the wall box.

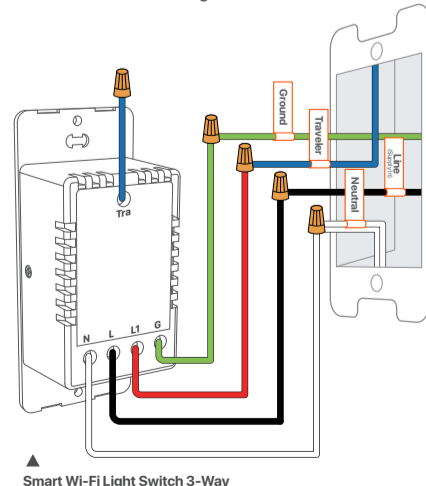

- Gently fold all wires back into the wall box and line up the Smart Wi-Fi Switch with the mounting holes. Secure it with included screws.

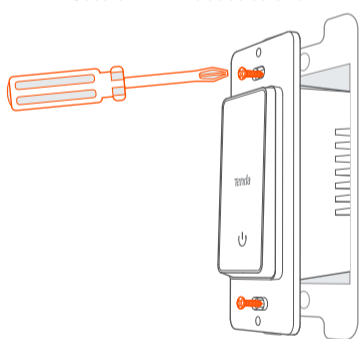

- Turn main power ON at the circuit breaker. Verify that the light can be turned on or off by pressing the Smart Wi-Fi Switch.

- Tips:**  
If the light is not on, try the following solutions:
- Confirm that the power is on.
  - Check that the wire match is correct.
  - If the problem persists, please consult an electrician.

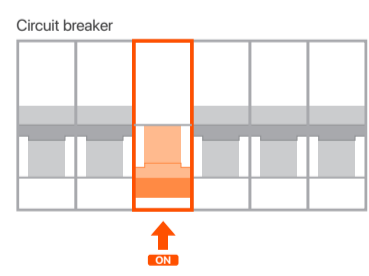

- Install the wall plate.

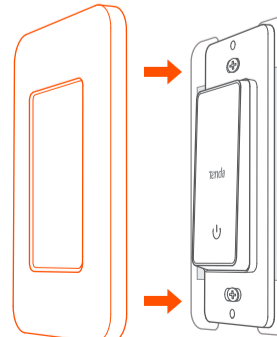

## Configure the device



- Tips:**
- The Smart Wi-Fi Switch only supports 2.4 GHz Wi-Fi network.
  - The default SSID (Wi-Fi name) of the Smart Wi-Fi Switch is **Tenda\_Smart Switch\_XXXX\_XXXX** indicates the last four characters of its MAC address which can be found on the device.

- Download the **Tenda Bell** App onto your mobile Wi-Fi-enabled device, such as a smart phone, by searching for **Tenda Bell** in the **App Store** or **Google Play** or by scanning the QR code.

- Follow the instructions in the App to add your **Smart Wi-Fi Switch**.



## FAQ

**Q1: What should I do when I failed to control the Smart Wi-Fi Switch After adding it on the Tenda Bell App?**

**A1:** Try the following solutions:  
If the LED indicator of the Smart Wi-Fi Light Switch lights solid blue:  
• Check whether the Wi-Fi network of your wireless router is enabled. If not, enable it.  
• Check whether the Wi-Fi name or password of your wireless router is changed. If so, reset the Smart Wi-Fi Switch, and re-configure it using the Tenda Bell App.

If the LED indicator of the Smart Wi-Fi Light Switch lights solid orange:  
• Check whether the router is connected to the Internet successfully.  
• Check whether the Wi-Fi name or password of your wireless router is changed. If so, reset the Smart Wi-Fi Switch, and re-configure it using the Tenda Bell App.  
**Reset method:** Hold down the button for about 5 seconds to 8 seconds and release it when the LED indicator blinks orange.

**Q2: What devices can I control with the Smart Wi-Fi Switch?**

**A2:** You can control bedside lamp, LED lamp, ceiling lamp, and any other lamps in your home whose rated power does not exceed the maximum power (450W) of the Smart Wi-Fi Switch.

**Q3: How to control the Smart Wi-Fi Switch with voice-activated devices, such as Amazon Alexa or Google Assistant?**

**A3:** In your Tenda Bell App, tap the Smart Wi-Fi Switch in the Device page, then (for Amazon Alexa) or (for Google Assistant) to get the help.

**Q4: If Line and Load are both black, how should I distinguish them?**

**A4:** Try the following solutions:  
• The Load wire is usually coming from the top of the box. The line wire is usually coming from the bottom of the box.  
• Before removing the switch, test each wire with a voltage tester.

**NOTE:** Risk of electric shock. DO NOT touch any wires during this process and **TURN OFF THE POWER** before continuing the installation.

- Very carefully, press the voltage pen against each wire.
- The wire that causes the pen to glow red is the line wire.
- The wire that does not cause the pen to glow red is the Load wire.



## FCC Statement

This equipment has been tested and found to comply with the limits for a Class B digital device, pursuant to Part 15 of the FCC Rules. These limits are designed to provide reasonable protection against harmful interference in a residential installation. This equipment generates, uses and can radiate radio frequency energy and, if not installed and used in accordance with the instructions, may cause harmful interference to radio communications. However, there is no guarantee that interference will not occur in a particular installation. If this equipment does cause harmful interference to radio or television reception, which can be determined by turning the equipment off and on, the user is encouraged to try to correct the interference by one or more of the following measures:

- Reorient or relocate the receiving antenna.
- Increase the separation between the equipment and receiver.
- Connect the equipment into an outlet on a circuit different from that to which the receiver is connected.
- Consult the dealer or an experienced radio/TV technician for help.

Operation is subject to the following two conditions: (1) this device may not cause harmful interference, and (2) this device must accept any interference received, including interference that may cause undesired operation.

## Radiation Exposure Statement

This device complies with FCC radiation exposure limits set forth for an uncontrolled environment and it also complies with Part 15 of the FCC RF Rules. This equipment should be installed and operated with minimum distance 20cm between the device and your body.

## Caution:

Any changes or modifications not expressly approved by the party responsible for compliance could void the user's authority to operate this equipment.

This transmitter must not be co-located or operating in conjunction with any other antenna or transmitter.

Operating frequency: 2412-2462MHz

**NOTE:** (1) The manufacturer is not responsible for any radio or TV interference caused by unauthorized modifications to this equipment. (2) To avoid unnecessary radiation interference, it is recommended to use a shielded RJ45 cable.



## RECYCLING

This product bears the selective sorting symbol for Waste electrical and electronic equipment (WEEE). This means that this product must be handled pursuant to European directive 2012/19/EU in order to be recycled or dismantled to minimize its impact on the environment. User has the choice to give his product to a competent recycling organization or to the retailer when he buys a new electrical or electronic equipment.

Operating Temperature: 0°C - 40°C (32°F - 104°F)  
Operating Humidity: (10% - 90%)RH, non-condensing