PENTAX

W-1502N Series

Total Station Instruction Manual



Dear Customer:

Congratulations! We, PENTAX are proud to present you with an W-1502N instrument. Your total station is a rugged and reliable instrument whose performance and design are not surpassed.

To fully appreciate and protect your investment, we suggest that you take the necessary time to read and fully understand this manual. We have a dedicated service organization. If the need arises, please don't hesitate to call us.

Thank you for your trust and confidence.

NOTE:

Don't collimate the sun directly

Avoid insulating the instrument, and don't collimate the sun directly for protecting eyes and instrument.

Set up the instrument on the tripod

When using it please insure the connection between tripod and instrument is firm. It is better to work with wooden tripod for the measurement accuracy.

Assemble the tribrach on the instrument

The setting of tribrach would influence the accuracy. The tribrach should be checked frequently, the screw which connects the tribrach and alidade must be locked tightly. And the central fixing screw should be tight.

Avoiding the librations on the instrument

When transporting, keep the instrument in the case and try your best to lighten librations.

Carry the instrument

When carrying, the instrument handle must be held tight.

High temperature condition

If put the instrument in high temperature condition for a long time, it is bad for the instrument performance.

Temperature changing sharply

The sharp temperature changing on the instrument or prism will shorten the distance measurement range, for example, after taking the instrument out from a warm car to a cold condition, wait for some time, it can be used when it adapts to the surrounding condition.

Check the battery power

Before using it, you should check the power whether it is enough.

Take out the battery

It is not suggested to take out the battery when the instrument is on, otherwise, the stored data may be lost, so it is better to replace the battery after power off the instrument.

Stored data responsibility

PENTAX should not be held liability for the lost data because of wrong operation.



The noise from the instrument

When the instrument is working, it is normal if you hear the noise from instrument motor, it will not affect the instrument work.

Definition of Indication

For the safety of your product and prevention of injury to operators and other persons as well as prevention of property damage, items which should be observed are indicated by an exclamation point within a triangle used with WARNING and CAUTION statements in this manual.

The definitions of the indication are listed below. Be sure you understand them before reading the manual's main text.

	WARNING: Ignoring this indication and making an operation error could possibly result in death or serious injury to the operator.
	CAUTION: Ignoring this indication and making an operation error could possibly result in personal injury or property damage.

PRECAUTIONS FOR SAFE OPERATION

WARNING

- Only PENTAX authorized distributors can disassemble or rebuilt the instrument.
- Do not collimate the sun directly. The eye injury or blind could result.
- Cover the charger maybe result fire when charging.
- If use defection power cable, socket or plug, there is danger of fire, or electronic shock.
- Using wet battery or charger maybe result fire, or electronic shock.
- Do not close the instrument to burning gas or liquid, and do not use the instrument in coal mine. Blast could be result.
- Do not put the battery in the fire or high temperature condition. Explosion, damage could result.
- If use the battery which is not specified by PENTAX, there is a danger of fire, electric shock or burn.
- If use the power cable which is not specified by PENTAX, there is a danger

of fire.

- If short circuit of the battery, there is a danger of fire..
- When this product encounters disturbance of severe Electrostatic Discharge, perhaps it will have some degradation of performance like switching on/off automatically and so on.



CAUTION

- If touch the instrument with wet hand, there is danger of electric shock.
- Stand or seat on the carrying case, or turn over the carrying case arbitrarily, the instrument maybe damaged.
- Be careful of the tripod tiptoe when setup or move it.
- Drop the instrument or the carrying case, or use defective belt, agraffe or hinge, instrument damage could result.
- Do not touch liquid leaking from the instrument or battery. Harmful chemicals could cause burn or blisters.
- Please assemble the tribrach carefully, if the tribrach is not stable, series damage could result.
- Drop the instrument or tripod, series damage could result. Before use it, check the central screw is tight.

User

1) This product is for professional user only!

The user is required to be a qualified surveyor or have a good knowledge of surveying, in order to understand the user manual and safety instructions, before operating, inspecting or adjusting.

2) Wear the required protectors (safety shoes, helmet, etc.) when operating.

Exceptions from Responsibility

1) The user of this product is expected to follow all operating instructions and make periodic checks of the product's performance.

2) The manufacturer assumes no responsibility for results of a faulty or intentional usage or misuse including any direct, indirect, consequential damage, and loss of profits.

3) The manufacturer assumes no responsibility for consequential damage,

and loss of profits by any disaster, (an earthquake, storms, floods etc.).

4) The manufacturer assumes no responsibility for any damage, and loss of profits due to a change of data, loss of data, an interruption of business etc., caused by using the product or an unusable product.

5) The manufacturer assumes no responsibility for any damage, and loss of profits caused by usage except for explained in the user manual.

6) The manufacturer assumes no responsibility for damage caused by wrong transport, or action due to connecting with other products.

Safety Standards for Laser

W-1502N series adopts the safe and visible laser on the basis of "Specification Standard of radiant products" (FDA CDRH.21CFR Part 1040.10 and 1040.11) and "Safety of laser products – parts 1: Equipment classification, requirements and user's guide" (IEC 60825-1:2001).

According to above standards, W-1502N series is class IIIa/3R laser products. When the prism or reflective sheet is selected in Config mode as target, the output is equivalent to the safer class 1.

Once the instrument is damaged, do not disassemble it. You'd better contact PENTAX or local dealer.

Labels

Follow the safety instructions on the labels as well as in this manual to ensure safe use .



Note for Safety



WARNING

- Never point the laser beam at other's eyes, it could cause serious injury.
- Never look directly into the laser beam source, it could cause permanent eye damage.
- Never stare at the laser beam, it could cause permanent eye damage.
- Never look at the laser beam through a telescope or other optical devices, it could cause permanent eye damage.

FCC Statement

This equipment has been tested and found to comply with the limits for a Class B digital device, pursuant to Part 15 of the FCC Rules. These limits are designed to provide reasonable protection against harmful interference in a residential installation. This equipment generates uses and can radiate radio frequency energy and, if not installed and used in accordance with the instructions, may cause harmful interference to radio communications. However, there is no guarantee that interference will not occur in a particular installation. If this equipment does cause harmful interference to radio or television reception, which can be determined by turning the equipment off and on, the user is encouraged to try to correct the interference by one or more of the following measures:

- Reorient or relocate the receiving antenna.
- Increase the separation between the equipment and receiver.
- Connect the equipment into an outlet on a circuit different from that to which the receiver is connected.
- Consult the dealer or an experienced radio/TV technician for help.

This device complies with part 15 of the FCC Rules. Operation is subject to the following two conditions:

(1) This device may not cause harmful interference, and (2) this device must accept any interference received, including interference that may cause undesired operation.

Changes or modifications not expressly approved by the party responsible for compliance could void the user's authority to operate the equipment.

CONTENT

1. Nomenclature and Functions.....	1
1.1 Nomenclature.....	1
1.2 Keyboard.....	3
1.3 Main menu.....	4
1.3.1 Basic Measurement.....	4
1.3.2 STD Measurement(Optional).....	5
1.3.3 Instrument Setup.....	5
1.3.4 About.....	6
1.3.5 Professional field software.....	6
1.3.6 Convenient panel.....	6
1.4 Shortcut key.....	7
1.5 Touch screen calibration.....	8
1.6 Battery.....	9
1.6.1 Battery Power indicator.....	9
1.6.2 Replace and mount battery.....	10
1.6.3 Recharge battery.....	10
1.7 USB connection.....	11
1.8 Guide light(Optional).....	12
2. Preparation before Measurement.....	13
2.1 Setting up the instrument.....	13
2.2 Levelling-Up.....	13
2.3 Centering.....	16
2.3.1 Centering with Optical Plummet (Optional).....	16
2.3.2 Centering with Laser Plummet.....	16
3. Instrument settings.....	17
3.1 INST Setup.....	17
3.1.1 Setting the measure condition.....	18
3.1.2 Setting the units.....	18
3.1.3 Setting parameters of communication ports.....	19
3.1.4 Instrument parameters review.....	19
3.2 Illumination settings.....	20
4. Basic measurement program.....	21
4.1 Run the program “Basic Measurement”.....	21
4.2 Basic measurement screen introduction.....	21
4.3 Angle measurement mode.....	22

4.3.1 Horizontal angle(right angle) and vertical angle measurements. .	22
4.3.2 Horizontal angle switch between right and left.	23
4.3.3 Setting horizontal angle with the "L.Angle" key.	24
4.3.4 Setting horizontal angle with the "S.Angle" key.	25
4.3.5 Setting "vertical angle and percent grade" mode with the "V/%" key.	26
4.3.6 Carrying out angle retesting with the "Repeat" key.	27
4.4 Distance measurement mode.	31
4.4.1 Distance measurement and measuring mode setting.	31
4.4.2 Fine/Tracking distance measurement.	32
4.4.3 Accurate Measurement and Track mode.	34
4.4.4 Exchange of distance units.	35
4.4.5 Distance stake out measurement.	35
4.4.6 Remote Elevation Measurement (REM)	37
4.4.7 Missing Line Measurement (MLM).	42
4.4.8 Line-height Measurement.	45
4.5 Coordinate Measurement Mode.	50
4.5.1 Setting coordinate of occupied point.	50
4.5.2 Setting backsight point.	51
4.5.3 Setting instrument height and prism height.	53
4.5.4 Operation of coordinate measurement.	54
4.5.5 Traverse Surveying.	55
4.5.6 Offset Measurement Mode.	58
4.6 About.	68
5. Check and Adjustment.	69
5.1 The Instrument Constant.	69
5.2 Plate Level and Circular Level.	70
5.2.1 Plate Level.	70
5.2.2 Circular Level.	70
5.3 The Optical Sight.	71
5.4 Optical Plummet and Laser Plummet.	71
5.4.1 Optical Plummet(factory optional).	71
5.4.2 Laser Plummet.	72
5.5 Vertical Cross-hair on Telescope.	73
5.6 Horizontal Collimation Error C.	74
5.7 Vertical Index Error.	75
5.8 EDM Optical Axis and the Telescope Sighting Axis Error.	77
6. Specifications.	78
8. Standard components.	81
Appendix I: Atmospheric correction formula and chart(Just for reference)	

.....	82
Appendix II: Correction for refraction and earth curvature.....	84
Appendix III: Assembling and disassembling for three-jaw tribrach.....	85

1. Nomenclature and Functions

1.1 Nomenclature





Eyepiece

Battery clamp

Plate

Vertical clamp knob

Vertical tangent knob

Battery clamp

Tribrach clamp

Horizontal clamp knob

Horizontal tangent

USB port

1.2 Keyboard



W-1502N series is equipped with two color touch screens and alphanumeric keypad, operation by both touching screen and pressing keyboard is possible.

Do not touch the screen with ball-pen, pencil or other sharp thing to avoid damage on instrument.

Keys	Name	Functions
0~9/ A~!	Alphanumeric keypad	Enter text and numerical values.
α	Shift key for character entry	The current entry method can shift among number, smaller letter and capital letter.
★	Star key	Normal configurations can be set here
Tab	Tab key	Move the cursor right or next position
BS	BackSpace key	Move the cursor left and delete one character
Ctrl	Ctrl key	Same with the Ctrl key of PC
Space	Space key	Enter the space
Enter	Enter key	Confirm an entry or selection
ESC	Escape key	Quit a screen or edit mode without saving changes. Return next higher level
FUNC	Function key	Perform variable functions defined

		by program screen
▲▼	Navigation key	Control the focus bar within the screen and the entry bar within a field
①	Power key	Turn on/off the instrument

1.3 Main menu

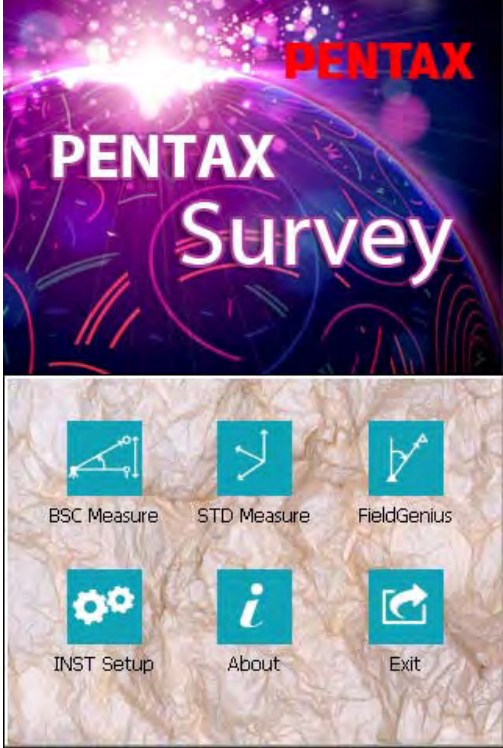
Function introduction	Display
<p>After initiating the instrument the screen will go to present "Welcome Interface" which is shown right. PENTAX Survey consists of several functions, that is, "BSC Measure (Basic Measurement)", "STD Measure (Standard Measurement)", "Engineering Surveying FieldGenius", "INST Setup (Instrument Setup)" and "About (Relevant Information)".</p>	

1.3.1 Basic Measurement

Function introduction	Display
<p>Click "BSC Measure" key to activate basic measuring. This function is used for simple measuring and calculating, including angle measurement, distance measurement, coordinate measurement and parameter setting. Distance measurement mode underpins Remote Elevation Measurement and Line-height Measurement. Coordinate measurement mode includes Traverse Surveying, Angle Offset Measurement,</p>	

<p>Distance Offset Measurement, Plane Offset Measurement, and Column Offset Measurement.</p> <p>Besides, basic measurement is also used for performance testing for total station.</p>	
--	--

1.3.2 STD Measurement(Optional)

Function introduction	Display
<p>STD measurement function is used to resolve and calculate applied measurements during conventional surveying. It contains "project management", "import/export", "instrument station setup and orientation", "foresight measurement", "backsight measurement", "side-looking measurement", "cross-sectional measurement", "setting out of point, bunch and alignment", "road design", "traverse adjustment", "coordinate geometry", "batter board label", "steel ruler connection survey", "data query and editing" and so on.</p> <p>NOTE: This part is optional, it is normal to display as right figure.</p>	 <p>The screenshot shows a software window titled "STD Measure" with a menu bar (Project, Record, Edit, Program, Help) and a status bar. The main area displays "PRJ Info:" with the following details:</p> <ul style="list-style-type: none"> Cur PRJ: Default.fpj Mea Data: 0 Coor Data: 0 Fixed Data: 0 STA.PT: BKS.PT: SS.PT: FS.PT: <p>Below the software window is a large advertisement for Pentax TI Asahi Co., Ltd. featuring the text "WinCE Total Station" and version information: B.M V2.2.0.2 131002, S.T V2.2.0.2 131002, and C.D V2.2.0.2 131002.</p>

1.3.3 Instrument Setup

Function introduction	Display
<p>Instrument setup function is mainly applied for instrument settings, instrument calibration and generation and management of instrument constant. It is made up of a series of functions such as "compensator linear correction", "compensator zero correction", "horizontal axis error correction", "index correction", "instrument settings", "distance constant settings", "communication port settings", "configuration management", etc.</p>	

1.3.4 About

Function introduction	Display
<p>The "About" function Offers information of manufacturer and software version.</p>	

1.3.5 Professional field software

Function introduction	Display
-----------------------	---------

W-1502N provides professional surveying and cartography program, such as "PENTAX FieldGenius". In fact, PENTAX W-1502N supports more third-party softwares.

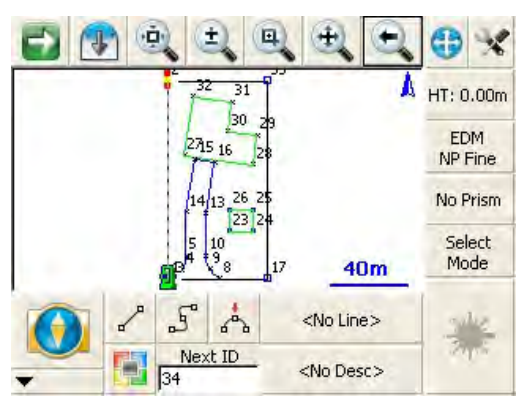

1.3.6 Convenient panel

Function introduction	Display
Click ★ key to enter into convenient panel. Electronic bubble function on this panel is used for dynamic display of electronic bubble during leveling up. Furthermore, functions like settings of meteorological condition, observed object, illumination, prism constant and communication port are provided.	

1.4 Shortcut key

1) Some shortcut keys are applied in 350 series.

Key combination	Description
⊙	Power on/off
★	Enter into setting mode directly/turn on the electronic bubble
α	Shift among number, smaller letter and capital letter
FUNC+BS+⊙	Enter this combination at the same time before starting up to backup all settings
FUNC+CTRL+⊙	Enter this combination at the same time before starting up to restore all settings
FUNC+SP+⊙	Enter this combination at the same time before starting up to erase all settings
FUNC+BS	Turn on/off backlight of key panel in face left position

FUNC+TAB	Turn on/off backlight of key panel in face right position
CTRL+ESC	Enter boot menu
CTRL+TAB	Start touch screen calibration
FUNC+CTRL	Turn on/off soft keyboards
FUNC+ ↑	Increase backlight brightness of LCD
FUNC+ ↓	Decrease backlight brightness of LCD
FUNC+←	Turn on/off LCD display in face left position
FUNC+→	Turn on/off LCD display in face right position

2) method for character entry switch

Press α key, current character entry method will be changed, on the lower right corner, the inputting method will display for a moment.

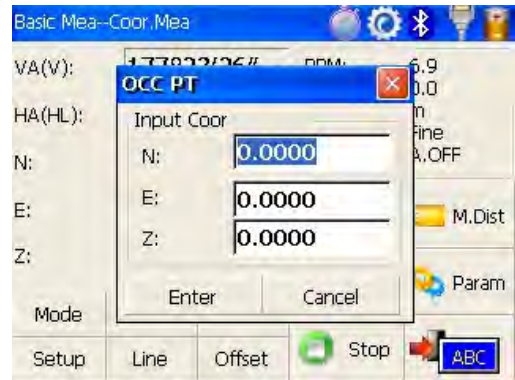
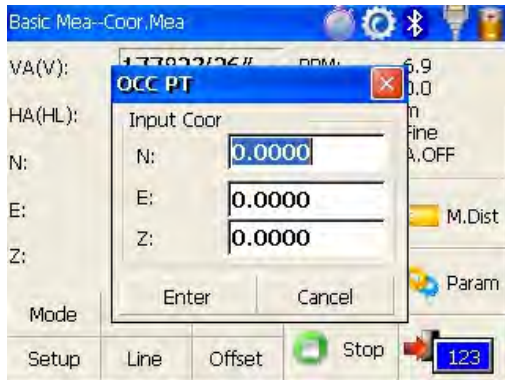

1.5 Touch screen calibration

When you operate on the screen, if your device isn't responding to you taps, you may need to recalibrate your screen. In any picture, press the combination key "CTRL+TAB" so as to enter into touch screen calibration. The calibration process is shown in the figure below.

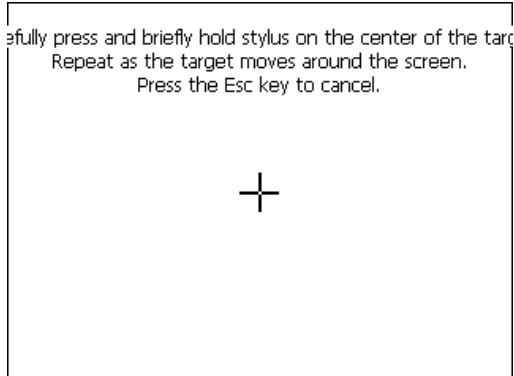

1) Carefully press and briefly hold stylus on the center of the target. Repeat as the target moves around the screen.

2) After all the targets are clicked, the screen will display as left, tap the screen to register saved data. The screen goes back to Stylus Properties menu.

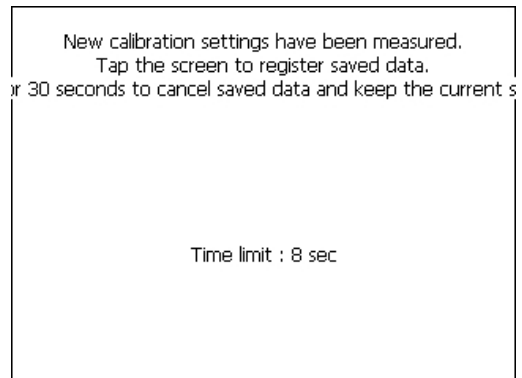

1.6 Battery

1.6.1 Battery Power indicator

At any screen, press 【★】 key to open fast setting menu.

Select Battery, battery level will be seen following **Battery Level**.

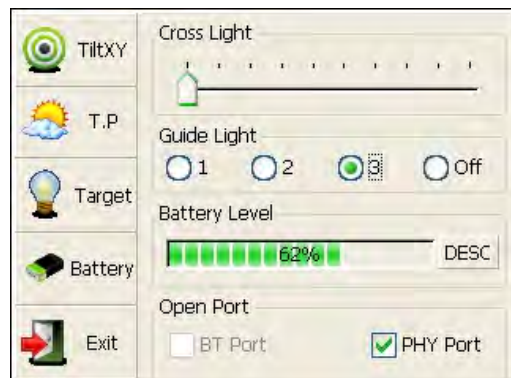



NOTE:

1. The battery's working time will be affected by many factors, such as ambient temperature, recharging time, recharging and discharging times. So we suggest the users recharge the battery full or prepare several full batteries before operation.
2. The battery symbol only indicates power capability for current measurement mode. The power consumption in distance measurement mode is more than in angle mode, if the instrument enters into distance measurement mode from angle mode, the power maybe auto-off because of lower battery.
3. The symbol only indicates the supply power but not the instantaneous power change. And if the measurement mode changes, the symbol will not show the power's decrease or increase immediately.
4. It is suggested that user should check every battery power before field work.

1.6.2 Replace and mount battery



Two battery are equipped with W-1502N, any one can work individually, so it is possible to take off one battery for recharging when the instrument is working.

1. Battery take off

- 1) As left figure shown, push down the flat battery clamp to take off the upper battery case.
- 2) As left figure shown, anticlockwise turn the round battery clamp 90° to take off the lower battery case.

2. Mount the battery

- 1) Put battery into battery case with contactor towards inside.
- 2) Push one battery case towards upper one box into the end, upper battery case will lock automatically

3) Push one battery case towards lower one box into the end,, clockwise turn the round battery clamp 90°to mount the lower battery case

1.6.3 Recharge battery

1)With battery power contactors touch with charger contactor, put battery into charger case by bayonet lock

2)Plug the charger on 100V/240V power supply.The red lamp becomes lighting,which indicates recharging.If interval-time is longer,the connector isn't fixed well.

3) That the green lamp flashes means recharging is complete.



NOTE: 1) New battery (or battery does not used for several months) should be recharged for several times.Please recharge it more than 10 hours, and then the battery can attain best status.

2) Please recharge the battery continuously for another 1~2 hours after the light green,which is good for the battery.

1.7 USB connection



- The file in the instrument could be read through ActiveSync software by USB cable.
 - External memory stick could be used by USB Host connector. The file in the external memory stick could be read in the instrument interface.
- 1) Open the cover of USB which behind the display panel;
 - 2) Input external memory stick into USB Host connector;
 - 3) The external memory stick could be recognized as hard disk automatically. It could be file copy etc.

1.8 Guide light(Optional)

Guide light is optional in W-1502N series total station. It is mainly used to stake out. The Surveyor could adjust the position of prism and station through the guide light color. It will be faster to set the prism.

The guide light could be seen within 100M. The distance will be effective by atmospheric conditions and others.

Under the face left, the Surveyor should move to left direction when he only saw the green light or the light became bigger; If only saw the red light or red light became bigger, the surveyor should move to the right direction. The move direction will be contrary when the telescope is in face right.

Guide light on/off: press **【★】** to open fast setting menu, select Battery, if the instrument is equipped with guide light module, 4 options for Guide light are active, ① ② ③ are for adjusting guide light intensity, select {Off} to turn off guide light.

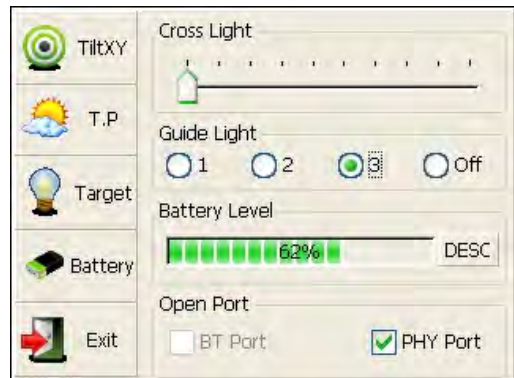
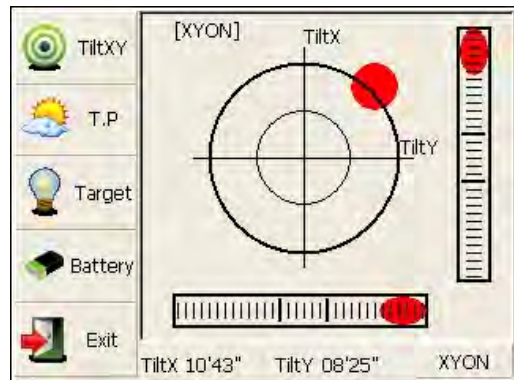

2. Preparation before Measurement

2.1 Setting up the instrument

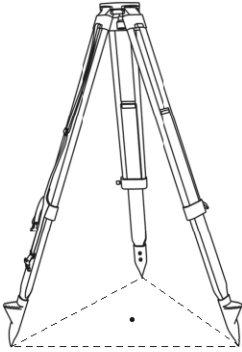

(1) Set up the tripod first: extend the extension legs to suitable lengths and tighten the screws on the legs. Make sure the legs are spaced at equal intervals and the head is approximately level. Set the tripod so that the head is positioned over the surveying point. Make sure the tripod shoes are firmly fixed in the ground.

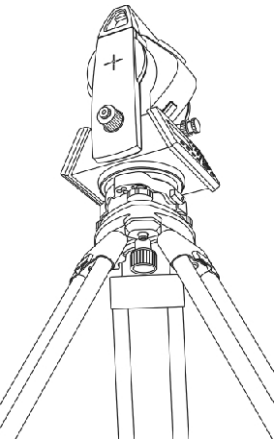

(2) Attaching the instrument on the tripod head: mount the instrument carefully on the tripod head. Supporting it with one hand, tighten the centering screw on the bottom of the unit to make sure it is secured to the tripod.

2.2 Levelling-Up

(1) Basic Levelling-Up with the circular level

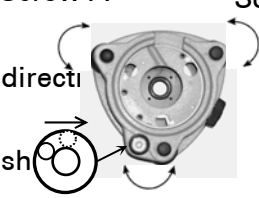
 <p>Screw A</p> <p>Screw</p> <p>directi</p> <p>sh</p> <p>Screw</p>	<p>1. Move the foot screws A and B in opposite directions so that the circular bubble is perpendicular to a line between screw A and B. The direction of rotation in left hand thumb indicates the movement of the circular bubble.</p>
---	---

2. Move the bubble to the center of the circle by screw C.

(2) Accurate Levelling-Up with plate level

	<p>1. Loosen the horizontal motion clamp, and turn the instrument till the plate level is parallel to a line shaped with screws A and B. Adjust the screws A and B to make the bubble in the center of the level.</p>
	<p>2. Loosen the horizontal motion clamp, and turn the instrument approximately 90°. Adjust the screw C until the bubble in the center of the level.</p>
<p>3. Repeat above steps until the bubble remains in the center of the plate level while the instrument is rotated to any position.</p>	

(3) Accurate Levelling-Up with Electronic Level on the screen

It is convenient for W-1502N series to level-up with electronic level, especially when it is difficult to observe the circular level and plate level.



Firstly, press the key 【★】 to turn on the electronic bubble as shown in left figure. On the electronic bubble screen, five function keys are displayed in the left column, which is listed as follows:

【TiltXY】 dynamic display of electronic bubble

【T.P】 observation and setting of temperature and atmospheric pressure

【Target】 target condition of surveying

【Battery】 dynamic display of battery level

【Exit】 exit the electronic bubble screen

Secondly, level it by turning three foot screws and ensure the bubble is in the plate level. Make sure the red spot is in the center.

Note:

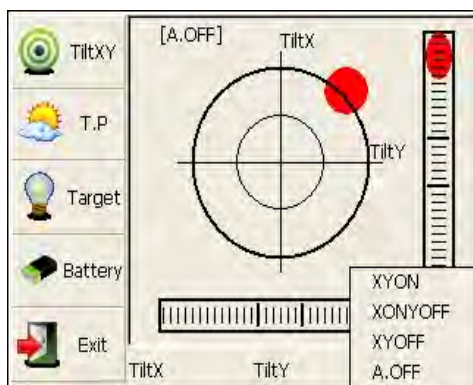

As shown, you can realize transformation of compensation options by pressing the lower right button.

【XYON】 compensate horizontal angle and vertical angle at the same time

【XONYOFF】 just compensate X axis

【XYOFF】 don't compensate X axis and Y axis

【A.OFF】 don't compensate X axis and Y axis, and turn off the popup function of electronic bubble.

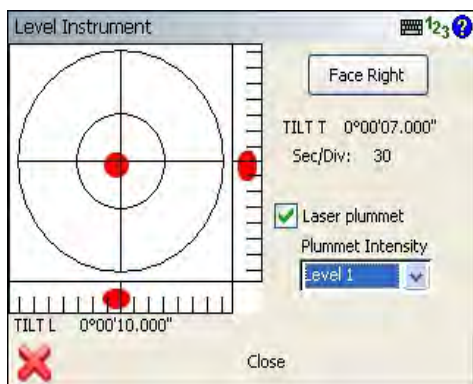

In PENTAX FieldGenius software, the Level display is always shown as left figure.

2.3 Centering

2.3.1 Centering with Laser Plummet

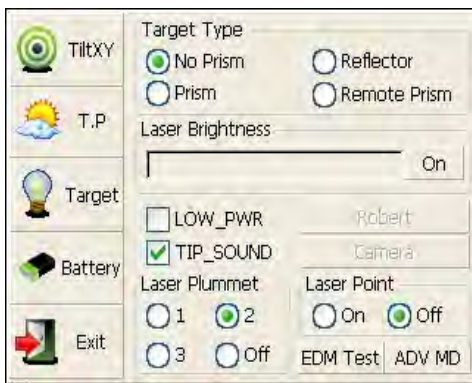

Press the key 【★】 to enter into the display as shown in the left figure.

Operation Steps:

① Click the “target” button, and you can turn on laser plummet and set it as three levels of brightness. Thus, that laser emits downwards can be seen.

② Loosen the center screw of tripod, and move the base plate on tripod head until the laser spot

coincides with ground mark point. Then tighten the center screw.

③ Repeat leveling and two steps until the instrument keeps leveling and the laser spot coincides with ground mark point when rotating alidade of instrument in any direction.

④ After centering, please turn off laser plummet to save power.

3 Instrument settings

Instrument settings software is applied for settings and calibration of instrument, generation and management of instrument constant. It is made up of a series of functions such as "compensator linear correction", "compensator zero correction", "horizontal axis error correction", "index correction", "instrument settings", "distance constant settings", "communication port settings", "configuration management", etc.

3.1 INST Setup





Tap or keys to display other settings

Enter "instrument settings" program by clicking "INST Setup" icon on the desktop. And then input the password "12345678" to display configuration settings screen. On the screen tap or keys, different setting screen can be shifted.

NOTE: This password is open for all users, current configuration settings can be checked here, but not be adjusted. If you want to adjust these settings, please contact local distributor or PENTAX company.

3.1.1 Setting the measure condition

Operation:

1. The distance measurement mode will be: Fine, Coarse, Repeat Fine, Average Fine, Tracking.

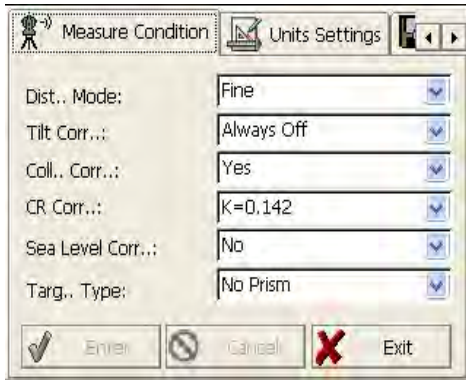

2. Tilt correction mode will be: HV, V, NO, Always off.

3. Collimator correction mode will be: Yes or No.

4. CR correction mode will be: K=0.142, K=0.2, No.

5. Sea Level correction mode will be: Yes or No.

6. Target Type mode will be: Prism, No Prism, Reflector. You could press

“Enter” to keep the setting or press cancelled.

3.1.2 Setting the units



Operation:

1. Angle unit mode will be: DMS, GON, MIL.

2. Angle Precision mode will be: 1 second, 0.1 second or 0.5 second.

3. Distance Unit mode will be: Meter, US Feet, Feet.

4. Distance precision mode will be: 1mm or 0.1mm.

You could press “Enter” to keep the

setting or press cancelled.

3.1.3 Setting parameters of communication ports

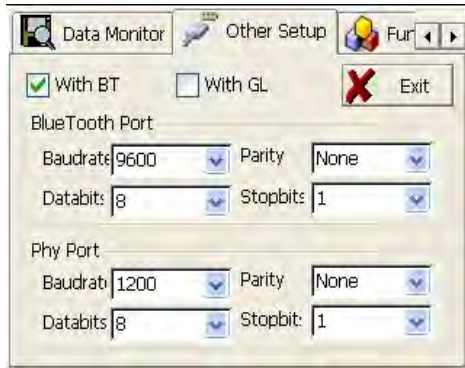

As left shows,click “Other Setup”,you can activate bluetooth(BT) and guidelight(GL),and set parameters of “Bluetooth Port” and “Phy Port”.

3.1.4 Instrument parameters review

Click “Data Monitor” used for reviewing the setting parameters.



3.2 Illumination settings



Press the 【★】 button and click “Target” and “Battery” keys in order to go on with illumination settings including “Cross Light”, “Guide Light”, and “Laser Point”.

Cross Light: Click this item to turn on the reticle illumination, and move the

slipping button to adjust reticle illumination.

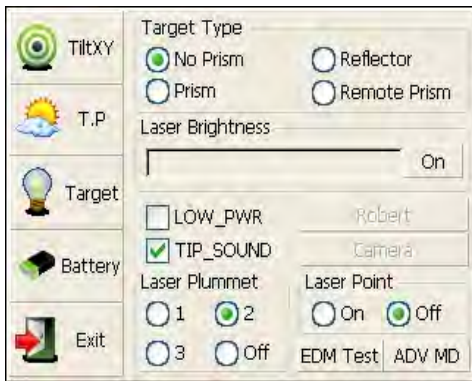

Guide Light: Click “Battery” key, resulting in display on which guide light could be adjusted.

Laser Point: Turn on/off the laser flash before distance measurement.



4. Basic measurement program

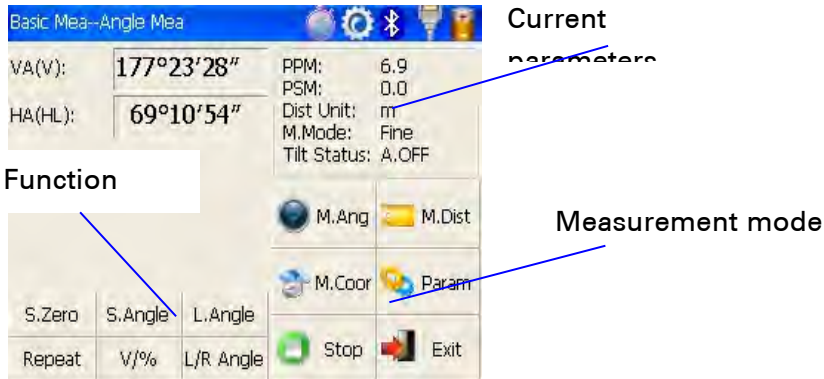

4.1 Run the program "Basic Measurement"

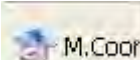

4.2 Basic measurement screen introduction

The function keys display in the lower left corner of screen, and they vary from one measurement mode to another. There are some function keys under every measurement mode being listed in the following table.

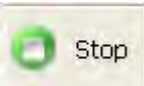
Measurement mode	key	function
	S.Zero	Set current horizontal angle as zero
	S.Angle	Set current horizontal angle
	L.Angle	Lock horizontal angle
	Repeat	Retest horizontal angle
	V/%	Switch between vertical angle and percent grade
	L/R Angle	Horizontal angle switch between left and right
	Mode	Set Fine, N Fine, Loop Fine, Track measurement mode
	m/ft	Switch among meter, international feet and American feet in terms of distance unit
	Setout	Set out measurement mode
	REM	Start REM function
	MLM	Start MLM function
	LHM	Start LHM function
	Mode	Set Fine, N Fine, Loop Fine, Track measurement mode



	OCC PT	Set the coordinate of instrument station
	S.BS	Set the coordinate of a backsight point
	Setup	Set instrument height and target height
	Line	Start traverse surveying
	Offset	Start offset measurement(ANG.Offset,DIST Offset,PLANE Offset,CYL.Offset) function
	Coor Order	Set displayed coordinate order as NEZ or ENZ
	Save Coor	Save coordinate of instrument station or not
	Ang.Unit	Set Ang.Unit as DMS,GON,MIL
	Dist Unit	Set Dist Unit as m,UsFeet,IntFeet
	Stop	Stop distance measurement
	Exit	Exit basic measurement program

4.3 Angle measurement mode

4.3.1 Horizontal angle(right angle) and vertical angle measurements

At first, make sure the operation is under angle measurement mode.

Operation steps	Keys	Display
① Collimate the first target A	Collimate A	

<p>②Set horizontal angle as zero for target A.Click the “S.Zero” button,and choose “OK” in the popup dialog box.</p>	<p>【S.Zero】 【OK】</p>	
<p>③Collimate the second first target B,and the horizontal angle and vertical angle will display on the screen of instrument.</p>	<p>Collimate B</p>	

4.3.2 Horizontal angle switch between right and left



Make sure the operation is under angle measurement mode.

Operation steps	Keys	Display
<p>①Make sure the operation is under angle measurement mode</p>		

<p>②switch horizontal angle between left and right by Clicking “L/R Angle” key ※1</p>	<p>【 L/RAngle 】</p>	
<p>※1 Left angle or right angle will be switched in turn every time you click the “L/R Angle” key.</p>		

4.3.3 Setting horizontal angle with the “L.Angle” key

Make sure the operation is under angle measurement mode.

Operation steps	Keys	Display
<p>①Turn horizontal circle unit in the needed direction with horizontal clamp and tangent part.</p>		
<p>②Click “L.Angle” key, and activate the function of locking horizontal angle.</p>	<p>【L.Angle】</p>	

<p>③Collimate target point used for Orientation. ※1</p>		
<p>④Click “unlock” key to deactivate the function of locking horizontal angle.Then the screen will return normal angle measurement mode,and meantime horizontal angle will be set as locked angle.</p>	<p>【Unlock】</p>	
<p>※1 Click “Cancel” key before it returns to Previous mode.</p>		

4.3.4 Setting horizontal angle with the “S.Angle” key

Make sure the operation is under angle measurement mode.



Operation steps	Keys	Display
<p>①Collimate target point used for Orientation.</p>		

<p>②Click “S.Angle” key, and a dialog box will be ejected, as is showed in the right figure.</p> <p>③Input horizontal angle you need.</p> <p>※ 1 Such as: 232°26'26"</p>	<p>【S.Angle】</p> <p>input horizontal angle</p>	
<p>④With data entry complete, click “Enter” key, and angle measurement after orientation will go on.</p>	<p>【Enter】</p>	
<p>※1 Data entry should be referred to the format shown in the dialog box.</p>		

4.3.5 Setting “vertical angle and percent grade” mode with the “V/%” key

Make sure the operation is under angle measurement mode.

Operation steps	Keys	Display
-----------------	------	---------



<p>① Make sure the operation is under angle measurement mode.</p>		
<p>② Click "V/%" key. ※1</p>	<p>【V/%】</p>	
<p>※1 Vertical angle and percent grade will be switched in turn every time you click "V/%" key.</p>		

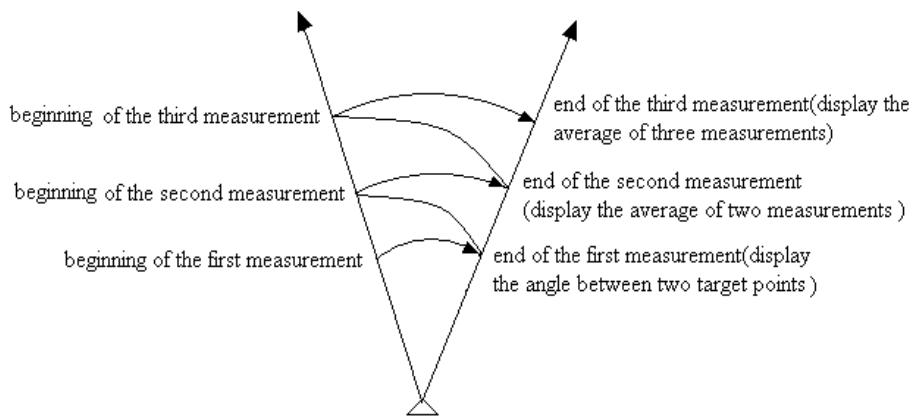

4.3.6 Carrying out angle retesting with the "Repeat" key

This program is applied for adding up angle retesting values, displaying the sum and the average of all observed values, and meantime recording the number of observations.



Operation steps	Keys	Display
<p>①Click "Repeat" key, and activate angle retesting function.</p>	<p>【Repeat】</p>	<p>The screenshot shows the following data and controls:</p> <ul style="list-style-type: none"> VA(V): 63°18'11" HA(HR): 232°21'22" PPM: 6.9 PSM: 0.0 Dist Unit: m M.Mode: Fine Tilt Status: A.OFF Buttons: M.Ang, M.Dist, M.Coor, Param, S.Zero, S.Angle, L.Angle, Repeat, V/%, L/R Angle, Stop, Exit

<p>②Collimate the first target A.</p>	<p>Collimate A</p>	
<p>③Click "S.Zero" key, and set horizontal angle as zero.</p>	<p>【S.Zero】</p>	
<p>④Collimate the second target B using horizontal clamp and tangent part.</p>	<p>Collimate B</p>	



<p>⑤Click “L.Angle” key.</p>	<p>【L.Angle】</p>	
<p>⑥Collimate the first target A again using horizontal clamp and tangent part. ⑦Click “Unlock” key.</p>	<p>Collimate A again 【Unlock】</p>	
<p>⑧Collimate the second target B again using horizontal clamp and tangent part. ⑨Click “L.Angle” key.And then the screen displays the sum and the average of all angles. ※1</p>	<p>Collimate B again 【L.Angle】</p>	
<p>⑩Repeat steps ⑥ ~ ⑨ according to the requirement,and carry out angle retesting. ※2</p>		
<p>※ 1 Click “Exit” key to finish angle retesting ※ 2 Ht:the sum of multiple observed values</p>		

Hm: the average of multiple observed values

4.4 Distance measurement mode

4.4.1 Distance measurement and measuring mode setting



Operation steps	Keys	Display
①Collimate the centre of prism.	Collimate	 <p>The screenshot shows the instrument's display in 'Basic Mea--Angle Mea' mode. The display is divided into several sections:</p> <ul style="list-style-type: none"> Top Bar: 'Basic Mea--Angle Mea' with icons for settings, Bluetooth, and other functions. Angle Readings: VA(V): 63°18'11" and HA(HR): 232°21'22". Parameters: PPM: 6.9, PSM: 0.0, Dist Unit: m, M.Mode: Fine, Tilt Status: A.OFF. Function Buttons: M.Ang (blue circle), M.Coor (blue globe), Stop (green square), M.Distance (yellow rectangle), Param (blue gear), and Exit (red arrow). Sub-parameters: S.Zero, S.Angle, L.Angle, Repeat, V/% (vertical), and L/R Angle (horizontal).

<p>②Click “M.Distance” key to enter distance measurement mode, and then the system will carry out measurement based on previous setting mode.</p>	<p>【M.Distance】</p>	
<p>③Click “Mode” key to activate setting function of distance measurement mode. Take “Loop Fine” as example here.</p> <p>Fine: single fine measuring mode N Fine: n times fine measuring mode Loop Fine: Continuous measuring mode Track: tracking measuring mode</p>	<p>【Mode】</p>	
<p>④Display the result of measurement. ※1~※2</p>		
<p>※ 1 Click “mode” key if you wanna change measurement mode,as step ③ shows.</p>		

※ 2 Click “M.Ang” key to return angle measurement mode.

4.4.2 Fine/Tracking distance measurement

When you preset the measuring times, the instrument will carry out distance measurement and display the average distance according to the setting times. If you preset single observation, the average distance won't be displayed. In general, the factory default is set as single observation.

Operation steps	Keys	Display
<p>① Under distance measurement mode, click “Mode” key to activate setting function of distance measurement mode. The default setting is “single observation”.</p>	<p>【Mode】</p>	
<p>② Click “N Fine” key with stylus, and then input the number of needed observations in the upper right column of screen.</p>	<p>【N Fine】 input the number of observations</p>	



<p>③Click “Enter” key, collimate the centre of prism,and then the system will carry out measurement based on previous setting. ※1</p>		
<p>※1 Click “M.Ang” key to return angle measurement mode.</p>		

4.4.3 Accurate Measurement and Track mode

Accurate Measurement mode:it’s a normal measurement mode.

Track mode:Track mode takes less time than accurate measurement.It is mainly applied for setting-out survey and useful for tracking moving target.



Operation steps	Keys	Display
-----------------	------	---------

<p>①Collimate the centre of prism.</p>	<p>Collimate prism</p>	
<p>②Click "Mode" key to activate setting function of distance measurement mode.And this mode is set as "Track".</p>	<p>【Mode】</p>	
<p>③Click "Enter" key, collimate the centre of prism, and the system will carry out measurement based on previous setting.</p>	<p>【Enter】</p>	

4.4.4 Exchange of distance units

Change distance unit on the screen of distance observation.

Operation steps	Keys	Display
-----------------	------	---------

①Click "m/ft" key.	【m/ft】	
②Changed distance unit will display in the upper right corner. ※1		
※1 Distance unit will be exchanged among meter,american feet and international feet every time you click "m/ft" key.		



4.4.5 Distance stake out measurement

This function can display the difference between measured distance and preset distance.

Displayed Value=Observed Value - Standard(Preset) Distance

Setting out among all sorts of distance measurement modes(such as slope distance, horizontal distance and elevation difference) can be carried on.

Operation steps	Keys	Display
-----------------	------	---------

<p>①Click "Setout" key under distance measurement mode.</p>	<p>【Setout】</p>	
<p>②Select distance measurement mode (SD,HD,VD)to be set out, input required data and then click "Enter" key. ※1</p>		
<p>③Start setting out.</p>		
<p>※1 First of all,a prompt that reminds you to input SD to be set out is displayed in the popup dialog box. Click "Enter" key to execute SD setting out after inputing data. If you want HD setting out,need to input zero in "SD dialog box", click "Enter",and the system will eject "HD dialog box" automatically. HD setting out can go on after HD data entry. If you want VD setting out,need to input zero in both "SD dialog box" and "HD dialog box", thus the system will remind you to input elevation difference to be set out.</p>		

4.4.6 Remote Elevation Measurement (REM)

The Remote Elevation program calculates the vertical distance (VD) of a remote object relative to ground. When using a prism height, the remote elevation measurement will start from the prism (reference point). If no prism height is used, the remote elevation will start from any reference point in which the vertical angle is established. In both modes, the reference point should be perpendicular to the remote object.

1) With prism height (PH) input

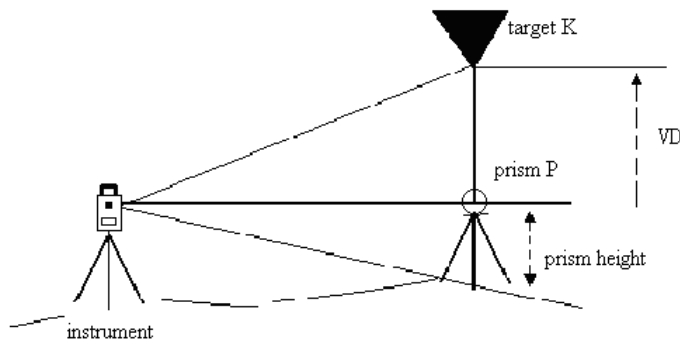



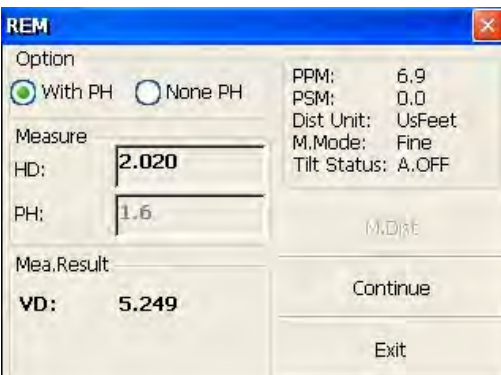
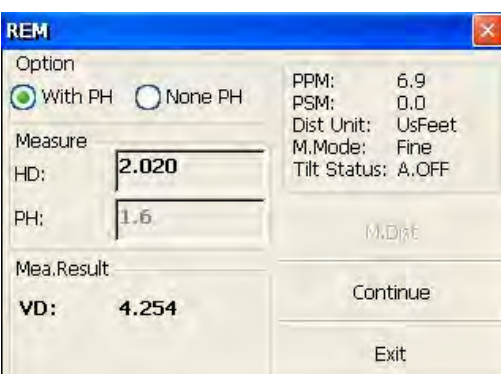

Operation steps	Keys	Display
① Under distance measurement mode, click "REM" key to activate remote elevation measurement.	【REM】	

<p>②Select “with PH” button with stylus.</p>	<p>【with PH】</p>	 <p>The screenshot shows the 'REM' menu with the 'Option' section where 'With PH' is selected (indicated by a green dot) and 'None PH' is unselected. The 'Measure' section has empty input fields for 'HD' and 'PH'. On the right, the status shows PPM: 6.9, PSM: 0.0, Dist Unit: UsFeet, M.Mode: Fine, and Tilt Status: A.OFF. At the bottom, there are buttons for 'M.Distance', 'Continue', and 'Exit'.</p>
<p>③Input the prism height following PH.</p>	<p>Input prism height</p>	 <p>The screenshot shows the 'REM' menu with 'With PH' selected. The 'PH' input field now contains the value '1.6'. The 'HD' field remains empty. The status and buttons at the bottom are the same as in the previous screenshot.</p>
<p>④Collimate the centre P of prism. ⑤Click “M.Distance” key to start measuring. ⑥Horizontal distance between instrument and prism will be shown.</p>	<p>Collimate prism 【M.Distance】</p>	 <p>The screenshot shows the 'REM' menu with 'With PH' selected. The 'HD' input field now contains the value '2.020' and the 'PH' field contains '1.6'. The status and buttons at the bottom are the same as in the previous screenshots.</p>

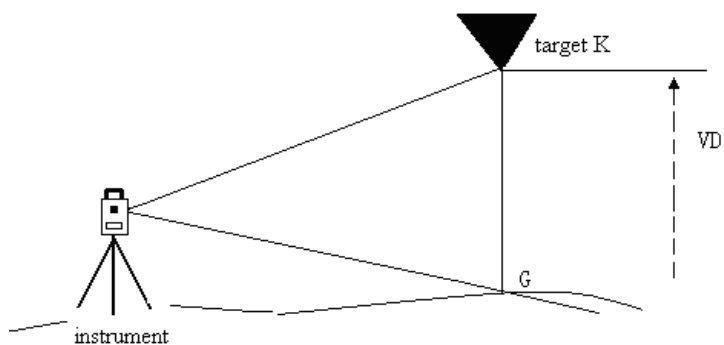
<p>⑦Click “Continue” key, and position of prism is locked, that means reference point is confirmed.</p>	<p>【 Continue 】</p>	
<p>⑧Collimate target K and click “Continue”, vertical distance (VD) will be shown. ※1)</p>	<p>【 Collimate K】</p>	
<p>※1)Click “Exit” key to finish REM.</p>		

2)without prism height input

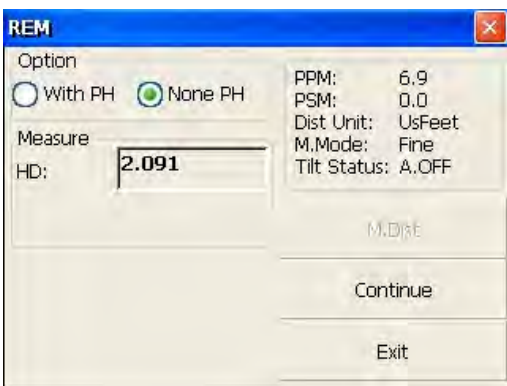

Operation steps	Keys	Display
<p>①Select “None PH” button with stylus.</p>	<p>【None PH】</p>	
<p>②Collimate the ground point. ③Click “M.Distance” key to start observing. ④Horizontal distance between instrument and prism will be shown.</p>	<p>Collimate prism 【M.Distance】</p>	
<p>⑤Click “Continue” key, and position of ground point G is locked that means reference point is confirmed.</p>	<p>【 Continue】</p>	

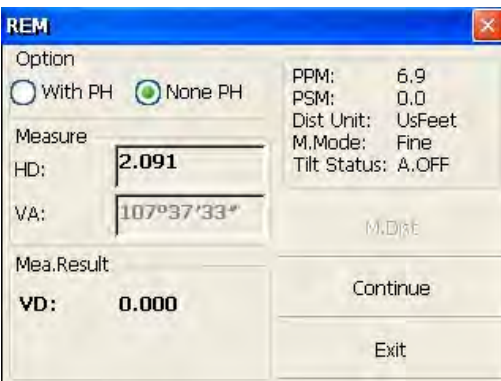
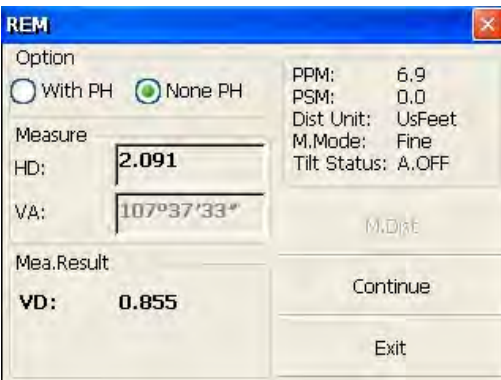
<p>⑥Click “Continue” key.</p>	<p>【 Continue 】</p>	
<p>⑦Collimate remote target distance(VD) will be shown. ※1)</p>	<p>Collimate target</p>	
<p>※1) Click “Exit” to finish REM.</p>		

4.4.7 Missing Line Measurement (MLM)

The Missing Line Measurement program calculates the horizontal distance (dHD), slope distance (dSD) and elevation (dVD) between two target prisms.



The instrument can accomplish this in two ways:

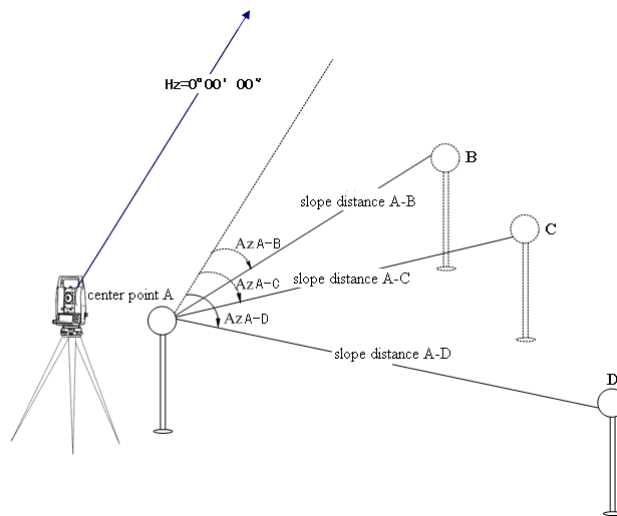

1. MLM Method (A-B, A-C): Measurement is A-B, A-C, A-D,

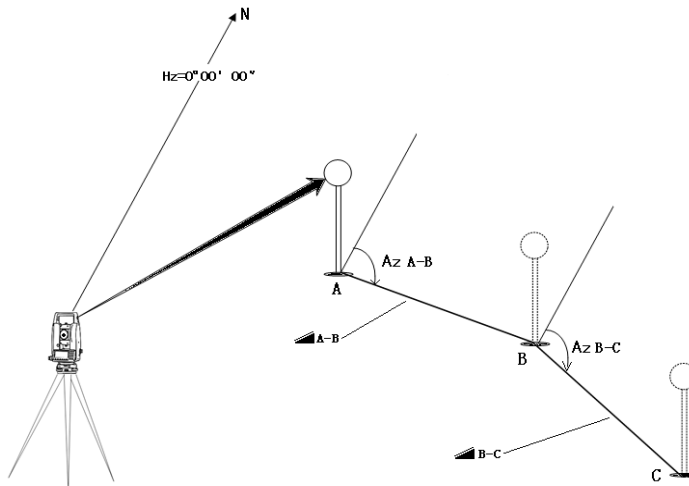

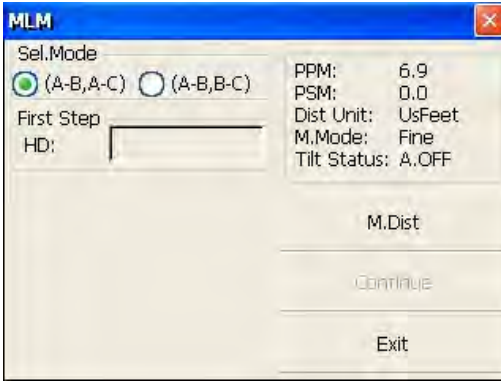
2. MLM Method (A-B, B-C): Measurement is A-B, B-C, C-D,



Operation steps	Keys	Display
<p>① Under distance measurement, click “MLM” key to activate Missing Line Measurement.</p>	<p>【MLM】</p>	
<p>② Select method (A-B, A-C) with stylus.</p>		
<p>③ Collimate prism A, click “M.Distance” key. Horizontal distance between instrument and prism A will be shown.</p>	<p>【M.Distance】</p>	

<p>④Collimate prism B,click “M.Distance” key.</p>	<p>【M.Distance】</p>	
<p>⑤Click “Continue” key,then horizontal distance(dHD), elevation difference(dVD) and slope distance (dSD) between prism A and prism B will display. ※1)</p>	<p>【Continue】</p>	
<p>⑥In order to calculate the horizontal distance between points A and C, collimate prism C, and click “M.Distance” key again. Thus horizontal distance between instrument and prism C will be shown..</p>	<p>【M.Distance】</p>	

<p>⑦Click “Continue” key,then dHD, dVD and dSD between prism A and prism C will be shown.</p>	<p>【Continue 】</p>	
<p>※1) Click “Exit” key to return main menu.</p>		

●Procedure of MLM Method (A-B, B-C) is completely same as Method (A-B, A-C) Method.

4.4.8 Line-height Measurement



This function is applied for measuring and determining a height of line(like electric wire)above ground which is hard to reach.

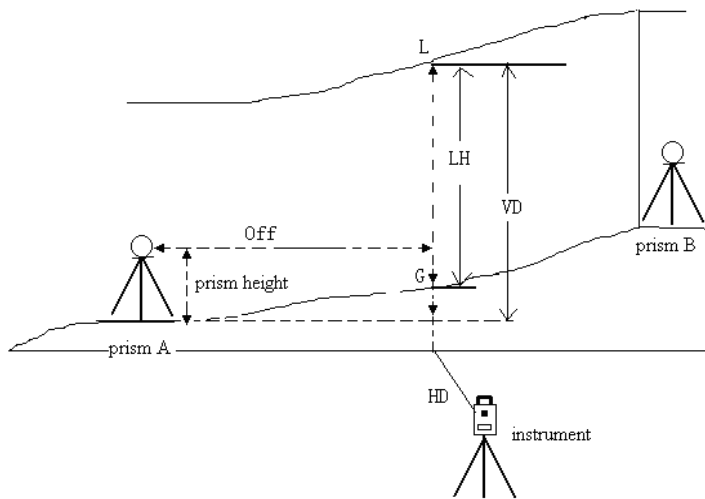

See following image, L is point on the overhead line, G is projective point on the ground, which is also difficult to set target, A and B are baseline which are set up in a certain distance under line. After measuring horizontal distances from instrument to prisms A/B and confirm the base line, VD between A and B, VD between L and G, HD between instrument and L(G),offset distance from A to L(G) will be determined and shown.

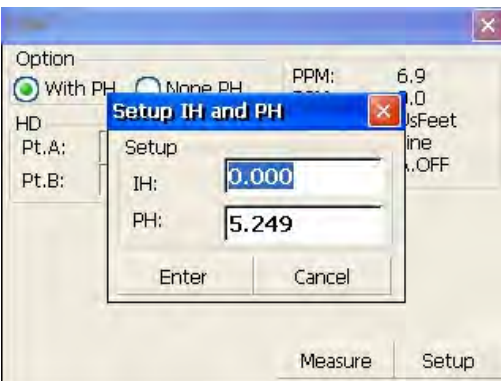
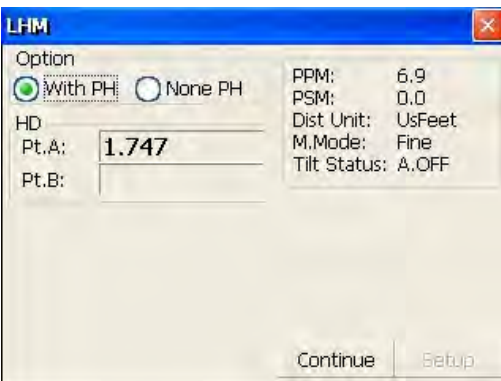
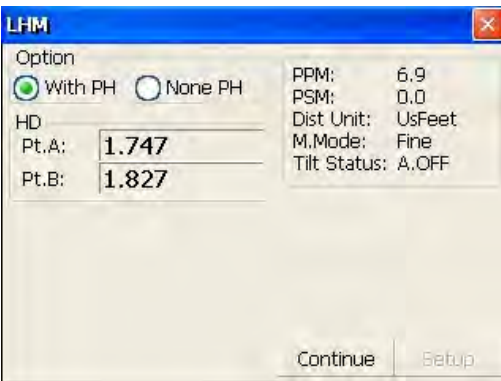

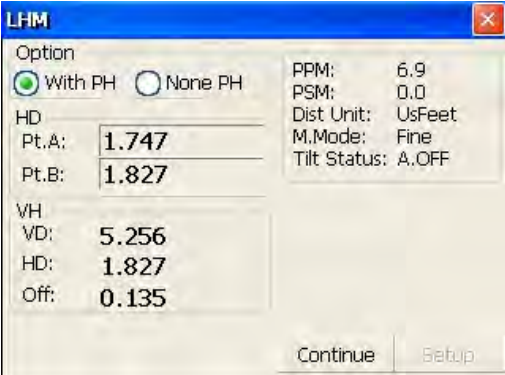
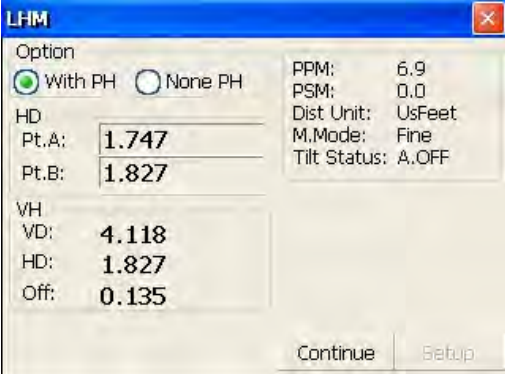
Operation steps	Keys	Display
① Under distance measurement mode, click "LHM" key to activate line-height measurement program.	【LHM】	
② Select "With PH" button with stylus.	With PH	

<p>③Click "Setup" key to input instrument height(IH) and prism height(PH).After that click "Enter" key.</p>	<p>【Setup】</p>	
<p>④Collimate prism A, click "Measure" key, and distance measurement begins. After that click "Continue" key.</p>	<p>【Measure】</p>	
<p>⑤Collimate prism B, click "Measure" key, and distance measurement begins.</p>	<p>【Measure】</p>	

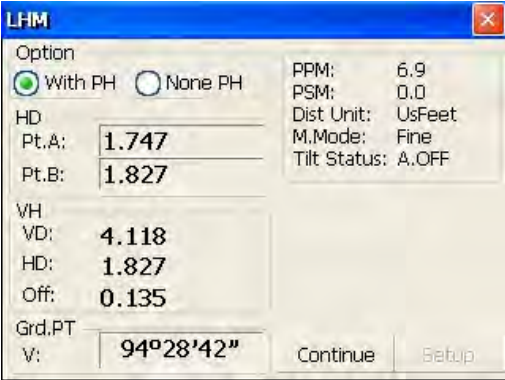
<p>⑥After measurement click "Continue" key.</p>	<p>【Continue】</p>	
<p>⑦Collimate point L on overhead line. The screen displays measuring data of collimating L. VD : Vertical distance between A and L. HD: Horizontal distance between instrument and L. Off: Horizontal distance between A and L.</p>		
<p>⑧Click "Continue" key which is used for measuring height between overhead line and ground. Operation steps: ●Collimate point on overhead line before clicking "Continue" key. ● Lock instrument on horizontal direction, move telescope on vertical direction until aim at ground point G.</p>	<p>【Continue】</p>	

<p>⑨Collimate ground point G by screwing vertical tangent part.</p>	<p>Collimate G</p>	
<p>⑩Click "Continue" key again, and then height of overhead line(LH) and horizontal distance(Off) will display. ※1)~※3)</p>	<p>【Continue】</p>	
<p>※1) Click "X" key to end measurement. ※2) Click "VH" key to return operation step⑦.</p>		



4.5 Coordinate Measurement Mode

4.5.1 Setting coordinate of occupied point

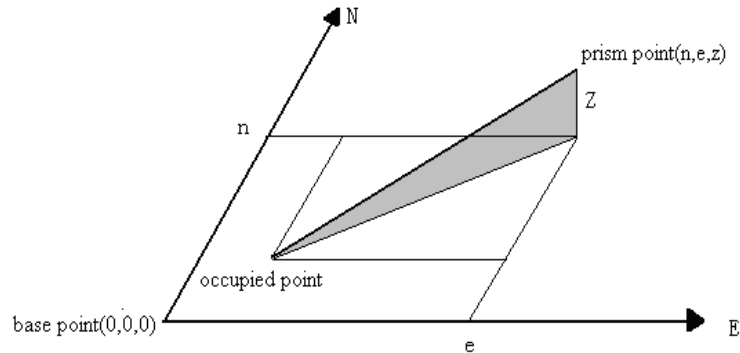
After input coordinate of occupied point (instrument location), unknown point coordinate will be measured and displayed with this program.





Operation steps	Keys	Display
①Click "M.Coor" key to enter coordinate measurement mode.	【M.Coor】	
②Click "OCC PT" key.	【OCC PT】	

<p>③Input coordinate of occupied point from N to Z.</p>		
<p>④Finishing data entry,click “Enter” key and return coordinate measurement interface.</p>	<p>【Enter】</p>	

4.5.2 Setting backsight point

Operation steps	Keys	Display
<p>①Click “S.BS” key to set backsight point.</p>	<p>【S.BS】</p>	

<p>②Input coordinate of backsight point and click “Enter” key.</p>	<p>【Enter】</p>	
<p>③A dialog box is ejected as figure shows.</p>		
<p>④Collimate backsight point, click “Yes” key. And then the system will define backsight azimuth angle which displays in the upper left corner of coordinate measurement screen.</p>	<p>【Yes】</p>	

4.5.3 Setting instrument height and prism height

Coordinate measurement must be based on instrument height and prism height, thus coordinate of unknown point can be calculated easily and directly.

Operation steps	Keys	Display
①Click "Setup" key.	【Setup】	
②Input instrument height (IH) and prism height (PH).	Input IH and PH	
③Finishing data entry, click "Enter" key to return coordinate measurement screen.	【Enter】	

4.5.4 Operation of coordinate measurement

With coordinate of occupied point, backsight azimuth angle, Instrument height and prism height set up, you can directly calculate coordinate of unknown point.

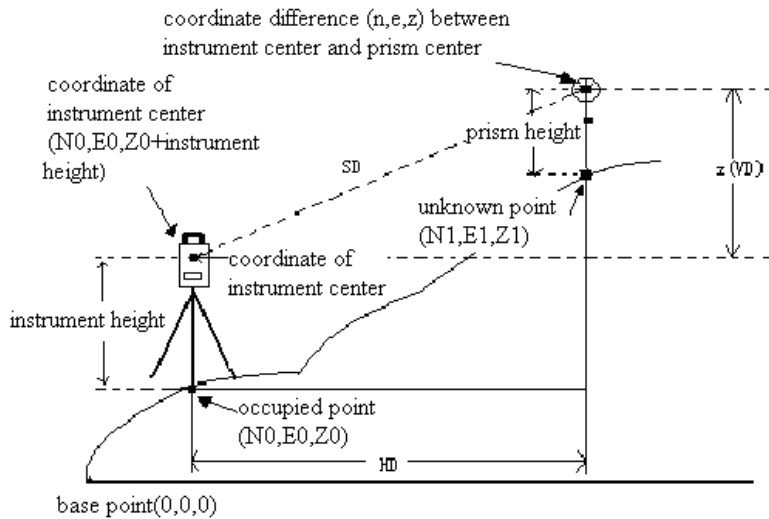

Operation steps	Keys	Display
① Set coordinate of occupied point and instrument height/prism height. ※1) ② Set backsight azimuth angle. ※2) ③ Collimate target. ※3)		

<p>④Click “M.Coor” key to finish operation. ※4)</p>	<p>【M.Coor】</p>	
<p>※1)If don't input coordinate of occupied point, previous coordinate of occupied point is set as default. If don't input instrument height and prism height, the previous is set as default too. ※ 2)refer to “4.3.4 Setting horizontal angle with the S.Angle key” or “4.5.2 Setting backsight point”。 ※3)Click “Mode” key to change distance measurement method(Fine/N Fine/Loop Fine/Track) ※4) Click “M.Angle” or “M.Dist” to return normal angle or distance measurement mode.</p>		

4.5.5 Traverse Surveying

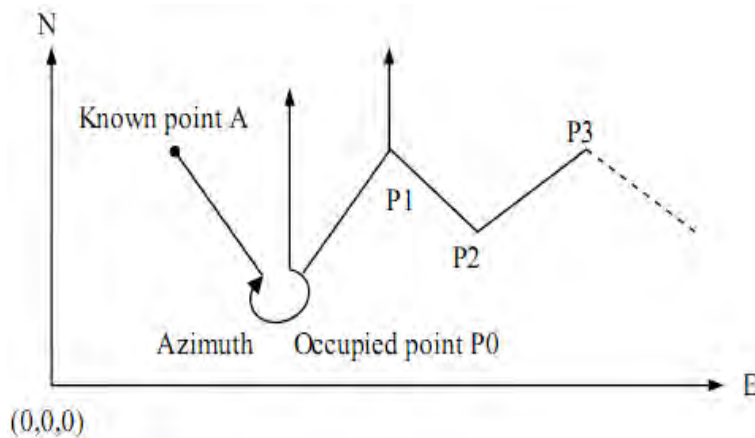

Measure the coordinate of foresight point and save it in the list, this point would be taken as the occupied point after transferring to point 2, and the previous occupied point will be taken as the backsight point, the azimuth angle will be calculated and set.

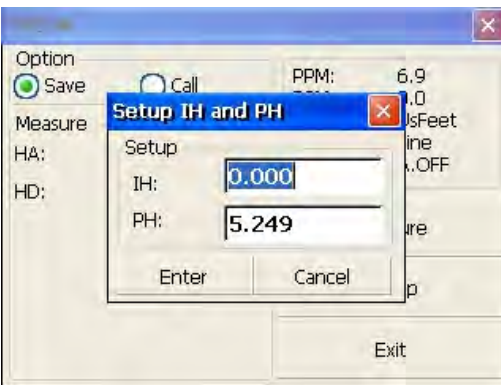
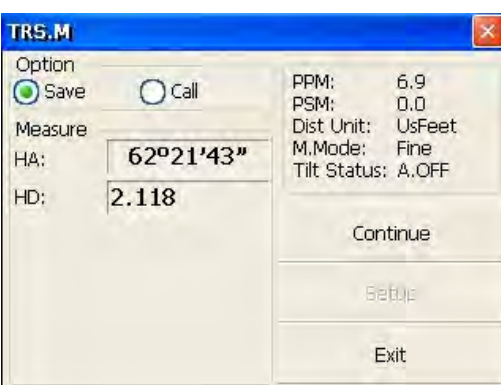
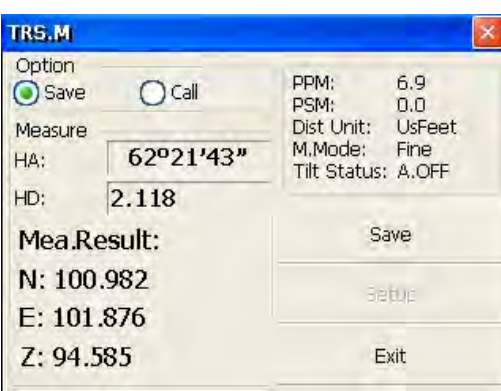

- ③ Set coordinate of occupied point p0 and azimuth angle from point P0 to known point A.

Operation steps	Keys	Display
① Click "Line" key.	【Line】	
② Click "Save" key with stylus.	【Save】	

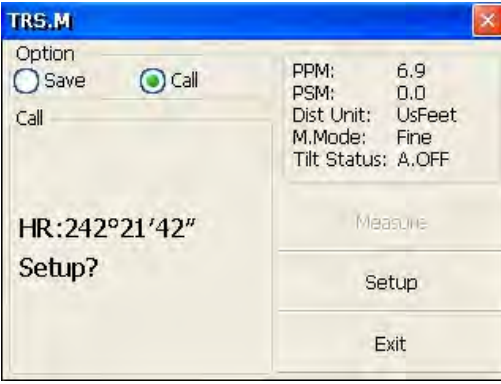
<p>③Click “Setup” key to reset instrument height and prism height. And then click “Enter” key.</p>	<p>【Setup】</p>	
<p>④Collimate prism in target point P1 where instrument will be transferred. Meantime click “Measure” key.</p>	<p>【Measure】</p>	
<p>⑤Click “Continue” key and coordinate of Point P1 displays in the lower left corner of screen.</p>	<p>【 Continue】</p>	

<p>⑥Click “Save” key. Coordinate of P1 can be ascertained and it will return main menu. At last power off and transfer instrument to P1 (transfer prism from P1 to P0 meantime).</p>	<p>【Save】</p>	
<p>⑦After instrument is established in P1, enter into traverse surveying of coordinate measurement and select “Call” button with stylus. ※1)</p>		
<p>⑧Collimate last occupied point P0. Click “Setup” key, then coordinate of P1 and azimuth angle from P1 to P0 will be ascertained. And it returns to main menu at the same time.</p>		
<p>⑨Repeat steps ① ~ ⑧, and carry on according to the sequence of guidelines till the end.</p>		
<p>※1) Click “Exit” key to finish Traverse Surveying.</p>		

4.5.6 Offset Measurement Mode

There are four kinds of Offset Measurement Modes:

- ③ Angle Offset Measurement
- ③ Distance Offset Measurement
- ③ Plane Offset Measurement
- ③ Column Offset Measurement

1) Angle Offset Measurement

This program is used to measure the point where it's difficult to set prism. Place the prism at the same horizontal distance from the instrument as that of point A0 to measure.

- When measuring coordinate of ground point A1 (projection of point A0), set instrument height and prism height.
- When measuring coordinate of point A0, set instrument height only (Prism height is set as 0).

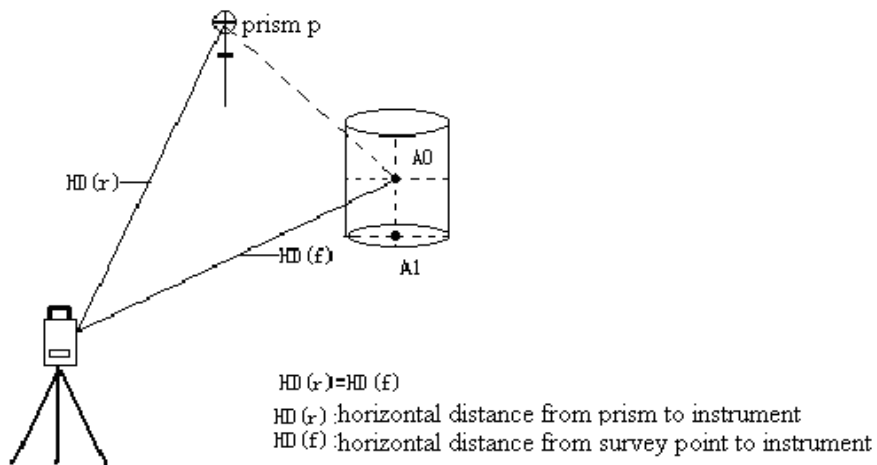





● Under angle offset measurement mode, there are two methods to set vertical angle:

1. Free vertical angle: vertical angle ranges from up-and-down movement of telescope.
2. Lock vertical angle: vertical angle is locked and can't range from up-and-down movement of telescope.

Thus, if collimate A0 with the first method, vertical angle ranges from up-and-down movement of telescope, and meantime slope distance (SD) and

elevation difference(VD) will change too. But if collimate A0 with the second method, vertical angle is locked in the direction where prism is located and can't range from up-and-down movement of telescope.

Operation steps	Keys	Display
<p>① Click "Offset" key.</p>	<p>【Offset】</p>	 <p>The screenshot shows the 'Basic Mea--Coor, Mea' screen with the following data: VA(V): 94°28'49", HA(HR): 242°21'42", N: 100.982, E: 101.875, Z: 94.585. A context menu is open over the 'Offset' key, listing options: ANG. Offset, DIST Offset, PLANE Offset, and CYL. Offset. Other visible options include M. Ang, M. Dist, Param, and Exit.</p>
<p>② Click "ANG.Offset" key in ejecting dialog box.</p> <p>③ Select "Free VA"(or "Lock VA") with stylus to to start angle offset measurement.(User makes a choice on the basis of own demand)</p>		 <p>The screenshot shows the 'ANG Offset' dialog box with the following options: Option: <input checked="" type="radio"/> Free VA, <input type="radio"/> Lock VA. Other data includes PPM: 6.9, PSM: 0.0, Dist Unit: UsFeet, M.Mode: Fine, and Tilt Status: A.OFF. Buttons at the bottom include Measure, Continue, Setup, and Exit.</p>

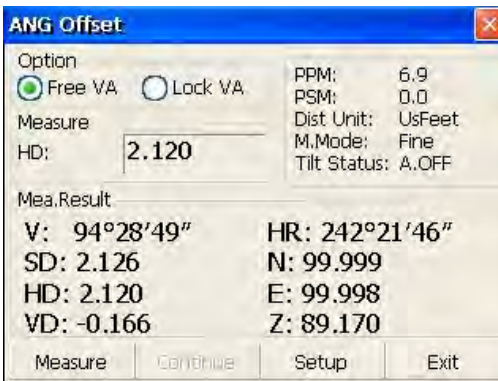
<p>④ Collimate prism P, and click "Measure" key.</p>	<p>Collimate prism P</p>	
<p>⑤ Collimate target A0 with horizontal clamp and tangent part.</p>	<p>Collimate A0</p>	
<p>⑤ Click "Continue" key. Then slope distance, horizontal distance and elevation difference from instrument to A0 and coordinate of A0 will be shown. ※1), ※2)</p>	<p>【 Continue 】</p>	
<p>※1) Click "Setup" key to set instrument height and prism height. ※2) Click "Exit" to finish Angle Offset Measurement</p>		

- Set instrument height/prism height before Offset Measurement.
- Refer to "4.5.1" to set coordinate of occupied point.

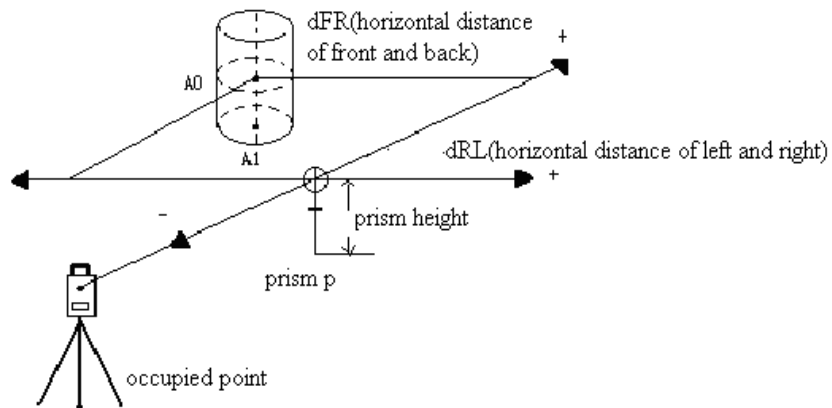

2) Distance Offset Measurement

The measurement of a target point apart from a prism is possible by inputting offset horizontal distance of front and back/left and right.



- When measuring coordinate of ground point A1, set instrument height and prism height.
- When measuring coordinate of point A0, set instrument height only (Prism height is set as 0).
- Refer to "4.5.1" to set coordinate of occupied point.

Operation steps	Keys	Display
<p>① Click "DIST Offset" key in ejecting dialog box.</p>	<p>【 DIST Offset 】</p>	
<p>② Finish data entry with stylus.</p>		

<p>③Collimate prism and click “Measure” key.</p>	<p>【Measure】</p>	
<p>④Click “Continue” key,and result displays with the correction of offset distance. ※1), ※2)</p>	<p>【 Continue 】</p>	
<p>※1) Click “Setup” key to set instrument height and prism height. ※2) Click “Exit” key to finish Distance offset measurement.</p>		

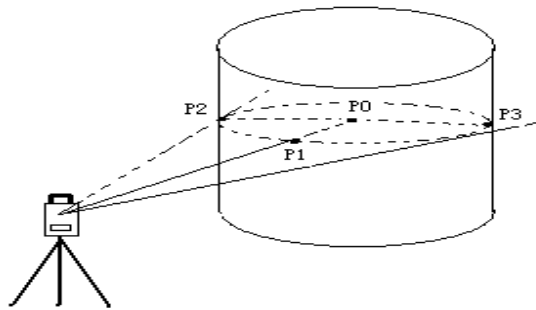

3) Column Offset Measurement

It is possible to measure circumscription point(P1) of column directly,the distance to the center of column(P0),coordinate and direction angle can be calculated by measured circumscription points P2 and p3.The direction angle of the center of column is 1/2 of total direction angle of circumscription points P2 and P3.



- Refer to “4.5.1” to set coordinate of occupied point.

Operation steps	Keys	Display
① Click “CYL.Offset” key.	【CYL.Offset】	

<p>②Collimate the center(P1) of column surface,and then click "Measure" key.</p>	<p>【Measure】</p>	
<p>③Collimate left point(P2) of column surface,and then click "Continue" key.</p>	<p>【Continue】</p>	
<p>④Collimate right point(P3) of column surface.</p>		

<p>② Click "Continue" key, and relational values between instrument and the center of column(P0) can be calculated and shown. ※1), ※2)</p>	<p>【 Continue 】</p>	
<p>※1) Click "Setup" key to set instrument height and prism height. ※2) Click "Exit" key to finish column offset measurement.</p>		

4) Plane Offset Measurement

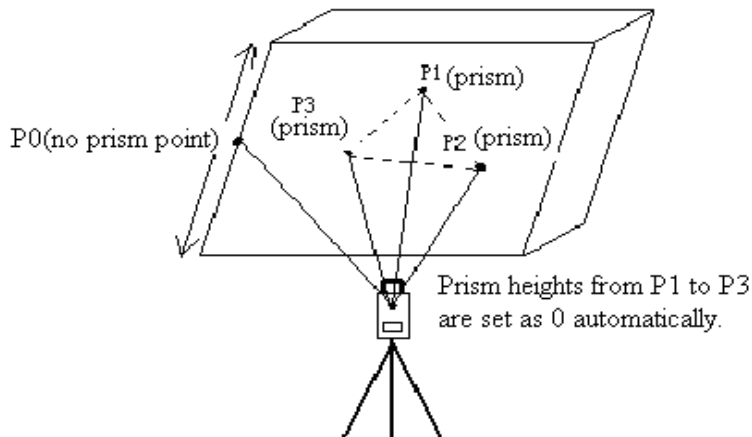

Measuring will be taken for the place where direct measuring can not be done, for example distance or coordinate measuring for an edge of a plane. Three random points(P1,P2,P3) on a plane will be measured at first in the plane offset measurement to determine the measured plane, collimate the measuring point(P0), the instrument calculates and displays coordinate and distance value of cross point between collimation axis and of the plane.

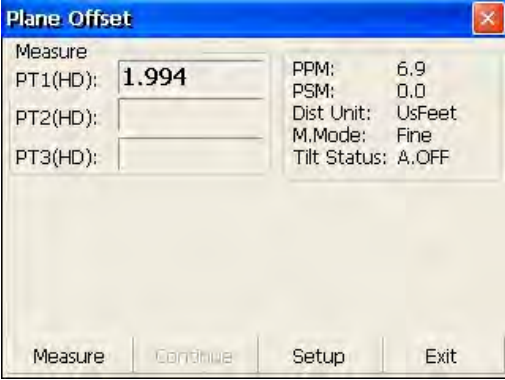
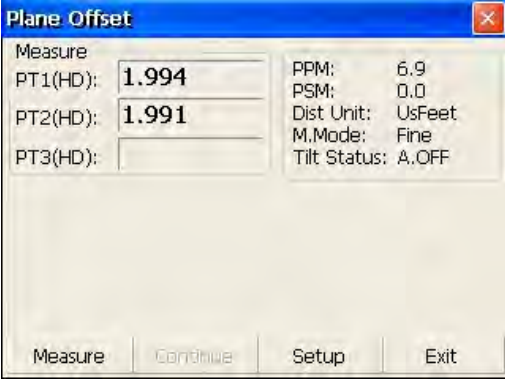

● Refer to "4.5.1" to set coordinate of occupied point.

Operation steps	Keys	Display
-----------------	------	---------

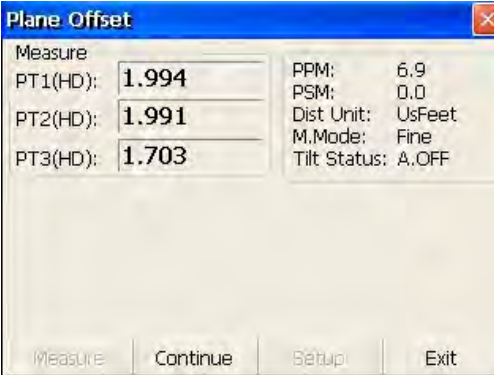
<p>① Click "PLANE Offset" key.</p>	<p>【 PLANE Offset 】</p>	 <p>The screenshot shows the 'Basic Mea--Coor, Mea' menu. The 'Mode' section has 'OCC PT' selected, and a sub-menu is open with 'PLANE Offset' highlighted. Other options in the sub-menu include 'ANG. Offset', 'DIST Offset', and 'CYL. Offset'. The 'Setup' section has 'Line' selected. The main menu also shows 'Coor' and 'Param' options.</p>
<p>② Collimate prism P1, and click "Measure" key.</p>	<p>【 Measure 】</p>	 <p>The screenshot shows the 'Plane Offset' dialog box. The 'Measure' section has 'PT1(HD):' set to '1.994'. The 'PT2(HD):' and 'PT3(HD):' fields are empty. The 'PPM:' field is set to '6.9', 'PSM:' to '0.0', 'Dist Unit:' to 'UsFeet', 'M.Mode:' to 'Fine', and 'Tilt Status:' to 'A.OFF'. The 'Measure' button is highlighted.</p>
<p>③ Collimate prism P2, and click "Measure" key.</p>	<p>【 Measure 】</p>	 <p>The screenshot shows the 'Plane Offset' dialog box. The 'Measure' section has 'PT1(HD):' set to '1.994' and 'PT2(HD):' set to '1.991'. The 'PT3(HD):' field is empty. The 'PPM:' field is set to '6.9', 'PSM:' to '0.0', 'Dist Unit:' to 'UsFeet', 'M.Mode:' to 'Fine', and 'Tilt Status:' to 'A.OFF'. The 'Measure' button is highlighted.</p>

<p>④Collimate prism P3, and click “Measure” key.</p>	<p>【 Measure 】</p>	
<p>⑤Click “Continue” key to calculate relational values between collimation axis and plane. ※1)</p>	<p>【 Continue 】</p>	
<p>※1)Click “Setup” key to set instrument height and prism height.</p>		

●If the three observing points can't determine a plane,the system will display error message.Thus observe the first point once again.

●When collimation axis doesn't intersect with determined plane, the system will display error message.

4.6 About



Operation:

1. Click "about" icon on desktop.
2. Press "Exit" to return the basic measurement.

5. Check and Adjustment

5.1 The Instrument Constant

1) Check

It is suggested to observe and compare the instrument with a testing line which is set on stable ground with a particular accuracy, though error is not generally included in the instrument constant. If the testing line is unavailable, you can set it for 20 meters or so by yourselves, then check and compare it with your new instrument.

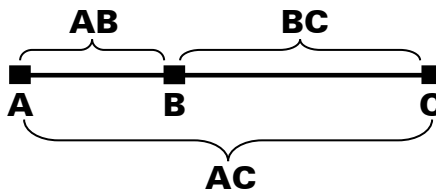

1. Select a point B on the approximately horizontal line AC with about 100 meters long. Measure the distances of lines AB , AC and BC .
2. The instrument constant can be calculated;
$$\text{instrument constant} = \text{AB} + \text{BC} - \text{AC}$$
3. If there is a difference between the instrument standard constant and the calculated value , colligate the measured constant and the prism constant to get a new value ,then input the value into the instrument as a prism constant .
4. Compare length of the instrument's testing line again with a certain standard testing line .
5. If the difference is over 5 mm after the preceding operations, it is necessary to reset the instrument constant .

2) Adjustment

About instrument constant setting, you must contact PENTAX distributor to do that.

5.2 Plate Level and Circular Level

5.2.1 Plate Level

1) Check

1. Mount the instrument on a stable device (as tripod , adjusting device),and fix it.
2. Level the instrument until the plate level is parallel to a line linking leveling foot screws A and B, then adjust the two screws to center the air bubble.
3. Turn the instrument 180°, observe the moving direction of the bubble, if it is still centered, no adjustment is necessary, if not, you have to adjust it.

2) Adjustment

1. Mount the instrument on a stable device and fix it.
2. Level it roughly.
3. Turn the instrument and make the plate level be parallel to a line linking two leveling foot screws, then adjust the two screws to center the air bubble .
4. Turn the instrument 180°, adjust the Adj-screw with adjustment pin slightly to correct half of the bubble's displacement when it doesn't move,
5. Repeat the operation (3) and (4) until the air bubble remains centered in any position .

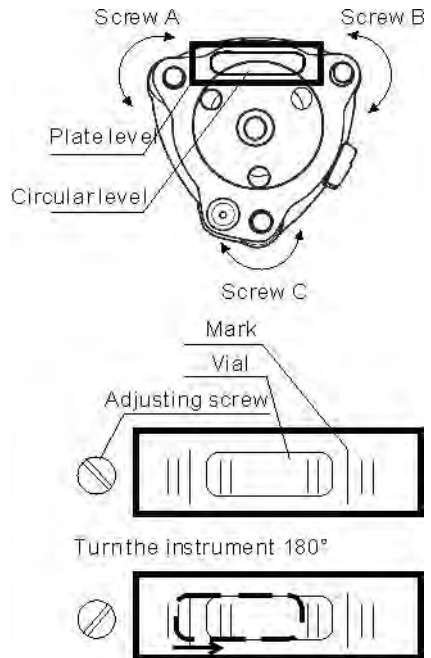

5.2.2 Circular Level

1) Check

1. Mount the instrument on a stable device and fix it.
2. Level it accurately by the plate level.
3. Observe the bubble of the circular level, if it is centered, no adjustment is necessary, if not, you have to adjust it.

2) Adjustment

4. Mount the instrument on a stable device and fix it.
5. Level it accurately by the plate level.
6. Adjust the three adjusting screws to center the bubble by a wrench.

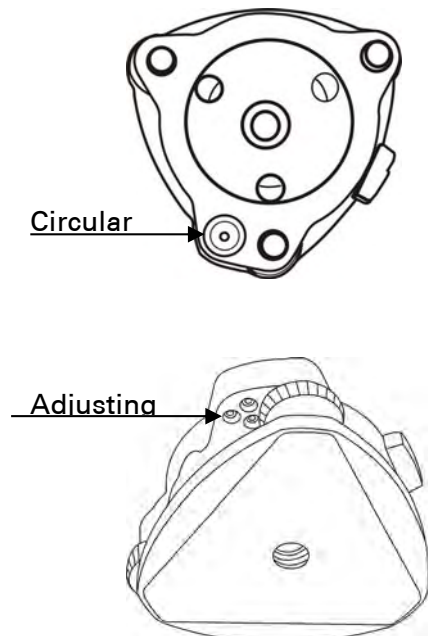

Note: Be careful when adjusting the three screws, and the tightening tension is identical for them.

5.3 The Optical Sight

1) Check

1. Mount the instrument on a tripod and fix it.
2. Set a cross mark target which apart from the instrument about 50m.
3. Take the telescope sight the cross mark.
4. Observe the optical sight collimator whether collimating the cross mark, if collimate the mark, adjustment is not necessary; if not, adjust it.

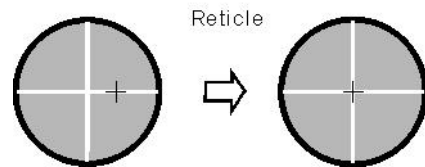
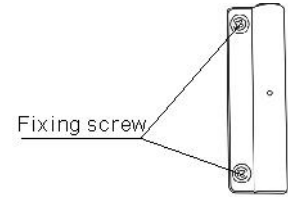

2) Adjustment

1. Mount the instrument at the tripod and fix it.
2. Set a cross mark target which apart from the instrument about 50m.
3. Take the telescope sight the cross mark.
4. Loosen two fixing screws, adjust the collimator, then fix the two screws again.

5.4 Laser Plummet

5.4.2 Laser Plummet

1)Check

1. Set the instrument on the tripod, and place a piece of white paper with a cross drawn on it right under the instrument.
2. Move the paper so that the intersecting point of the cross comes to the centre of the laser mark.
3. Rotate the instrument around the vertical axis, and observe the centre mark position against the intersecting point of the cross at each 90° rotation.
4. If the laser mark always coincides with the intersecting point, no adjustment is necessary.

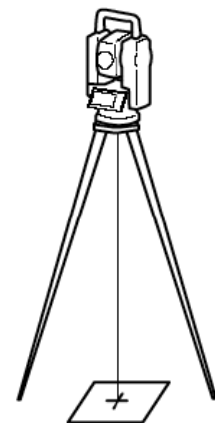

2) Adjustment

When a centre part where a cross intersection and the laser mark look the brightest shifts by 0.5mm or more (at the instrument height 1.5m), it is necessary to adjust it.

A repair engineer does this adjustment. Please contact the LINERTEC dealer.

5.5 Vertical Cross-hair on Telescope

1) Check

(1) Set the instrument up the tripod and carefully level it.

(2) Set a point A front the instrument 50m apart;

(3) Collimate the point A and adjust the vertical tangent screw; If the point appears to move continuously on the hair, adjustment is not required. Otherwise, adjust it.

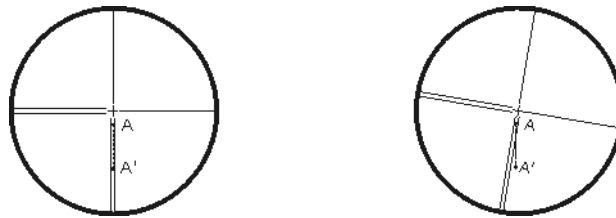

2) Adjustment

(1) Set the instrument, and set the point A front the instrument 50m apart.

(2) Take off cover of telescope eyepiece, there are 4 screws for the reticle part.

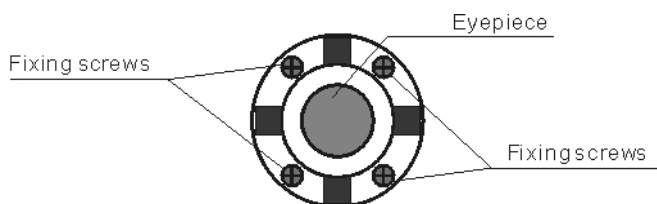

(3) Loosen all four fixing screws slightly with the cross screw-drive.

(4) Revolve the eyepiece section so that the vertical cross-hair coincides to point A, finally, re-tighten the four screws.

(5) Repeat the checking and adjusting until there is no deviation.

NOTE:

1) After the adjustment of cross-hair, please check the collimation error and vertical index error.

2) Refer to the chapter "5.9 EDM Optical Axis and the Telescope Sighting Axis Error" to check the axis. At last check the collimator error again.

5.6 Horizontal Collimation Error C

If the telescope's sight line isn't perpendicular to the horizontal axis, the collimation error will appear. The assembling, transportation and operation will cause this error.

If the collimation error isn't over the permitted range, with the program the instrument can correct this collimation error.

NOTE: After the program correction this deviation error is also on the instrument.

1) Check

(1) Set-up the instrument on tripod or adjustment platform and leveling accurately.

(2) Aim at the cross-hairs of collimator or the obvious target at a distance. Get the face left angle reading H1 and the face right angle reading Hr.

(3) Calculating the horizontal collimation error C according to $C = (Hl - Hr \pm 180^\circ) / 2$, if $C < 8''$, no adjustment will be necessary. If $C > 8''$, proceed with the following adjustment.

2) Adjustment by program:

Set-up the instrument on tripod or adjustment platform, and leveling accurately.



Procedures:

1. Power on, run the software "TS810Setup", on the screen tap or keys until Collimation displays, tap it to display collimation error and vertical index error setting menu.

2. Aim at the cross-hair of collimator at telescope left, tap "Left value" to read the horizontal and vertical angles.

3. Aim at the cross-hair of collimator at telescope right, tap "Right value" to read the horizontal and vertical angles.

4. The software will calculate the new collimation error and vertical index error automatically.

5. Tap "Enter" to save the new values, or tap "Cancel" to use old values.

Note:

The adjustment can be performed by the program when $C < 30''$, if $C > 30''$, adjust the reticle.

Reticle Adjusting:

1. Rotate the instrument in face right position, turning horizontal tangent screw until $Hr' = Hr + C$.

2. Loosen the shield of telescope's reticle.

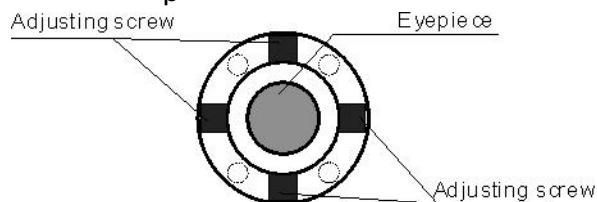

3. Adjusting two screws at left and at right until the vertical hairs of telescope's reticle coincides with the cross-hairs of collimator or target.

4. Repeat the check and adjustment procedure until the error is accepted.

NOTE:

1. When adjust the screws of reticle, firstly loosen the screw on the moving direction of reticle, secondly tighten another screw by the same mount, clockwise turning is for tightening, and anticlockwise turning is for loosening, the turning mount for tightening or loosening should be same.

2. After the reticle adjustment, it is necessary to adjust the vertical index error by program.

5.7 Vertical Index Error

The deviation between vertical circle zero position and horizontal direction is vertical index (i), it is necessary to concern this error when measure vertical angle. The instrument program applied a formula to remove this error. This correction can offer the index for the formula.

Warning: Before starting this operation, be sure to read manual carefully, otherwise it may cause data faulty.

Because of the close relationship between vertical index and compensator zero position, it is necessary to check and adjust compensator zero position when adjust the vertical circle, the value should be stable when reading.

1) Check:

Please adjust the reticle of telescope and correct the collimation error before this operation.

(1) Mount the instrument at the tripod or a stable device and level it accurately, then turn on the instrument.

(2) Aim at the cross-hairs of collimator or the obvious target at a distance, VA should be about $\pm 10^\circ$. Read the face left angle VI and face right angle Vr.

(3) Calculate the index error according to the formula below:

$$i = (VI + Vr - 360^\circ) / 2$$

(4) If $|i| < 10''$, no adjustment is necessary, or you have to adjust it.

2) Adjustment by program:

Set-up the instrument on tripod or adjustment platform, and leveling accurately.



Procedures

1. Power on, run the software "TS810Setup", on the screen tap or keys until Collimation display, tap it to display collimation error and vertical index error setting menu.
2. Aim at the cross-hair of collimator at telescope left, tap "Left value" to read the horizontal and vertical angles.
3. Aim at the cross-hair of collimator at telescope right, tap "Right value" to read the horizontal and vertical angles.
4. The software will calculate the new collimation error and vertical index error automatically.
5. Tap "Enter" to save the new values, or tap "Cancel" to use old values.

5.8 EDM Optical Axis and the Telescope Sighting Axis Error

It is necessary to check this error after the adjustment of telescope reticle error.

1) Checking (For 350 series)

(1) Install the instrument at the tripod or a stable device and level it accurately, then power on the instrument.

(2) Set a prism about 2m far away from the instrument.

(3) Aim at the prism center with telescope reticle.

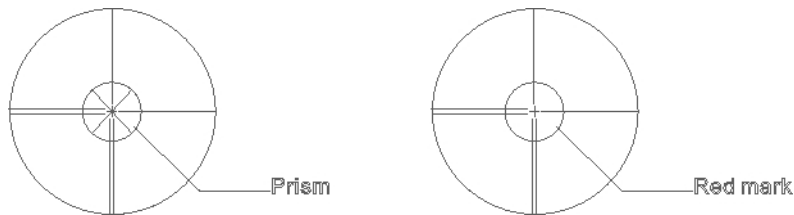

(4) Enter EDM signal testing screen.

(5) Observe through eyepiece, turn the focusing knob until the red mark is clear, if the deviation between mark and cross-hair is not over 1/5 of red mark diameter, adjustment is unnecessary.

2) Checking (For W-1502N series)

(1) Install the instrument at the tripod or a stable device and level it accurately, then power on the instrument.

(2) Set a reflective sheet about 5m-20m far away from the instrument.

(3) Aim at the sheet cross-mark with telescope reticle.



(4) Enter EDM signal testing screen.

(5) Observe the laser spot, if the laser spot coincides with the cross-mark of reflective sheet, adjustment is unnecessary.

NOTE:

Laser radiation do not stare into beam.

3) Adjustment

If the instrument needs adjustment, please contact with our dealers.



6. Specifications

W-1502N series

Telescope

Length	156mm
Image	Erect
Magnification	30x
Aperture	45mm
Field of view	1°30'
Minimum focus	1.0m

Angle measurement

Reading system	Absolute encoder
Circle diameter	79mm
Angle unit	360degree/400gon/6400mil, selectable
Minimum display	0.5" / 1" / 5" ,selectable 0.1mgon/0.2mgon/1mgon, selectable
Detecting mode	Double
Accuracy	2" / 5"

Distance measurement

Display resolution(m/inch selectable)	0.1mm/1mm	
Laser class	Prism	Class
1	Reflectorless/Reflective sheet	Class
3R		
Distance unit	m/ft, selectable	
Measurement range(good condition)	Single prism	1 to
5000m	Reflective sheet/RP60	1 to 800m
	Reflectorless	1 to 500m
Mini-reading	Fine	mode
0.1mm/1mm(0.001ft/0.01ft)	Tracking mode	10mm (0.1ft)
Accuracy	Prism:2mm+2ppm	
	Reflective sheet/RP60:3mm+2ppm	
	Reflectorless:1-200m:3mm+2ppm/	≥
200:5mm+3ppm		
Measurement time	Initial: 2.5s	

	Fine mode: 1.5 s
	Rapid mode: 0.9s
	Tracking mode: 0.5s
Prism	typ.1.0-1.5s
Reflective sheet/Rp60	typ.1.5s
Reflectorless	typ.1.5-5s,max.20s
Temperature unit	°C/°F, selectable
Pressure unit	hPa/mmHg/inchHg, selectable
Temperature input range	-30°C to +60°C (1°C steps)
Pressure input range	510hPa to 1066hPa(1hPa setps)
Prism constant condition	-99.9mm to +99.9mm
Refraction and earth curvature correction	OFF/0.14/0.2, selectable
Reflecting prism constant correction	-99.9mm to +99.9mm

Level vial sensitivity

Plate level	30" / 2mm
Circular level	8' / 2mm

Compensation

System	Dual-axis
Liquid type	
Range	± 3'
Resolving power	1"

Data processing system

Operating system	Windows CE
CPU	32 bit

Laser plummet(Standard)

Accuracy	±1.0mm/1.5m
Laser class	Class 2/IEC60825-1
Laser spot size/brightness	Adjustable
Laser wave length	635nm

Display

LCD screen	3.5" color TFT LCD(320x240dots), touch
	transflective sunlight readable display

Internal memory

Internal memory	SD Card
-----------------	---------

Power

Battery	3400 mAh Li-ion Rechargeable
---------	------------------------------

battery	
Voltage	7.4V DC
Continuous operation time every 30 seconds)	About 10 hours(single distance measurement)
Chargers	FDJ6-Li(100V to 240V)
Charging time (at +20°C)	Approx. 4 hours

Application programs

Data collection/Stake out/Resection/REM/MLM/Point to line
 AREA/Z coordinate/OFFset/3D Road/Traverse adjustment
 Tape measurement/section/axis positioning measurement

Others

CPU	ARM9 Core
Memory	2G internal memory
Guide Light System	Factory optional
Sensors	Built-in temperature and pressure sensors
Keyboard	Alphanumerical illuminated key board,both sides
Operating temperature	-20°~+50°C
Storage temperature	-40°~+70°C
Dimension(W×D×H)	210×210×360mm
Weight(including batteries)	5.5kg
Dimensions(W×D×H)	185×220×360mm
Interface	USB host/USB slave/RS-232C/Bluetooth(Optional)
Water and dust protection	IP55 (IEC60529)
Data collector	PS236,fully rugged PDA(Optional)

8. Standard components

● Carrying case	1 each
● Instrument	1 each
● Battery	2 each
● Charger	1 each
● Adjusting pins	2 each
● Cleaning cloth	1 each
● Cleaning brush	1 each
● Screwdriver	1 each
● Wrench	2 each
● Silica gel	1 each
● Instruction manual	2 each
● CD	1 each
● USB Communication cable	1 each
● RS232C Communication cable	1 each
● Rainproof	1 each
● Reflective sheet/RP30	4 each
● Reflective sheet/RP60	1 each
● Laser caution sign board	1 each

Appendix I: Atmospheric correction formula and chart(Just for reference)

Factory setting: temperature: 20°C, pressure:1013hpa, 0ppm

The correction:

$$K_{pt} = 274.417 - 0.2905 * p / (1 + 0.0036 * t)$$

Where: p--Pressure value (hPa)

t--Temperature value (°C)

K_{pt}--Atmospheric correction (ppm)

Example:

t=20°C, p=1013hpa, L₀=1000m.

Then: K_{pt}=0ppm

$$L = L_0(1 + K_{pt}) = 1000 \times (1 + 0 \times 10^{-6}) = 1000.000m$$

The atmospheric value is obtained easily with the atmospheric correction chart. Find the measured temperature in horizontal axis, and pressure in vertical axis on the chart.

Read the value from the diagonal line, which is the required atmospheric correction value.

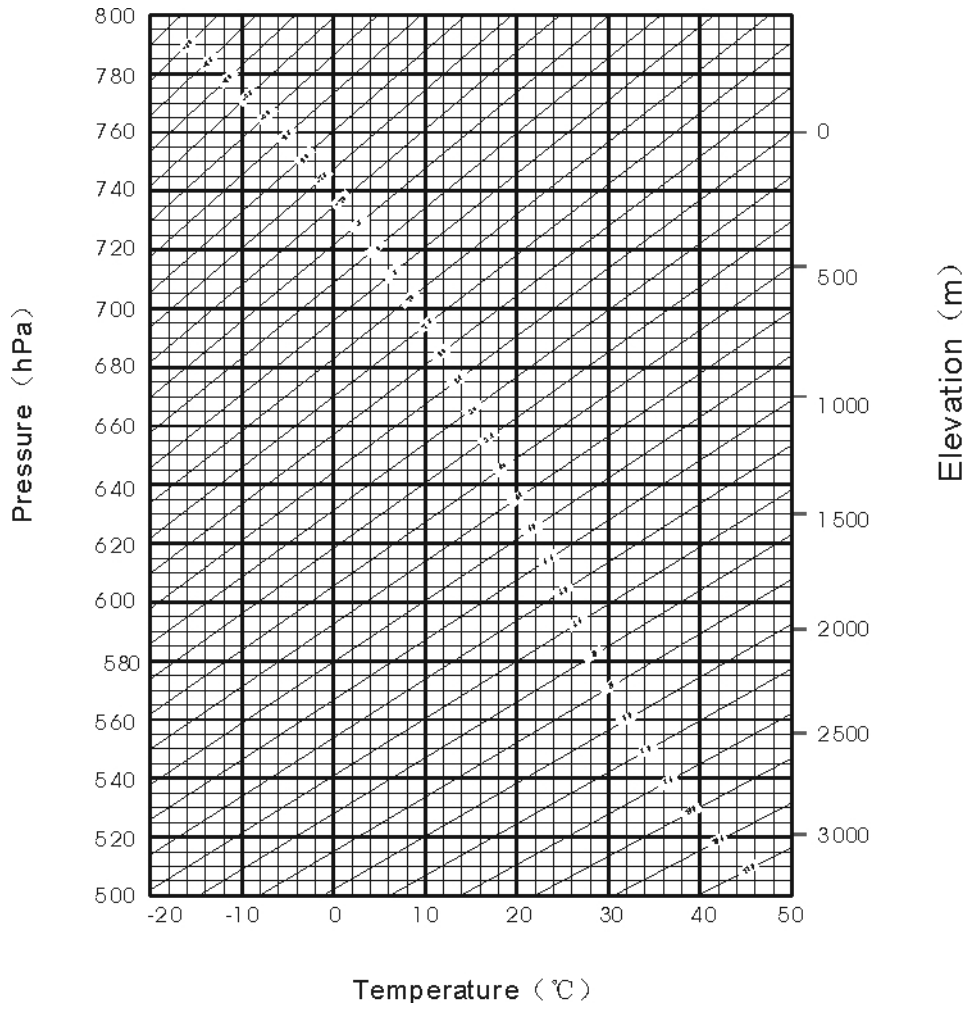

Appendix II: Correction for refraction and earth curvature

Considering the correction of refraction and earth curvature for distance measurement, the formula for slope distance, horizontal distance and vertical distance applied in the instrument are as followings:

$$SD = D_0 \times (1 + ppm \times 10^{-6}) + mm$$

SD — Displayed slope distance (m)

D_0 — Real measured distance (m)

ppm — Scale coefficient (mm/km)

mm — Target constant (mm)

$$HD = Y - A \times X \times Y$$

$$VD = X + B \times Y^2$$

HD — Horizontal distance (mm)

VD — Vertical distance (mm)

$$Y = SD \cdot |\sin \xi|$$

$$X = SD \cdot \cos \xi$$

ξ — Zenith angle

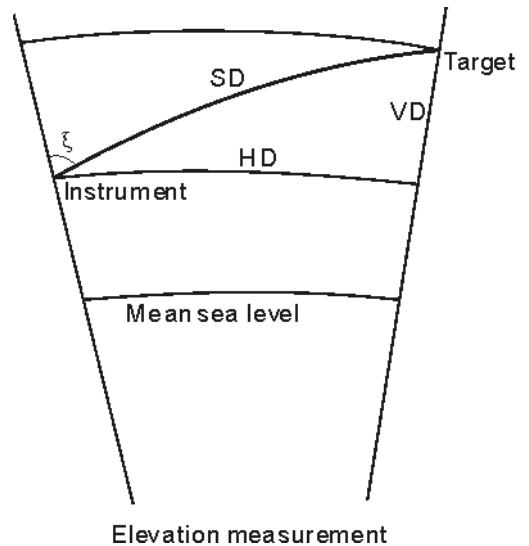

$$A = \frac{1 - \frac{K}{2}}{R}$$

$$B = \frac{1 - \frac{K}{2}}{2R}$$

$$K = 0.142 \text{ or } 0.20$$

$$R = 6.37 \times 10^6 \text{ (m)}$$

The conversion formula for horizontal and vertical distance is as follows when correction for refraction and earth curvature is not applied:

$$HD = SD \cos \xi$$

$$VD = SD |\sin \xi|$$

NOTE:

The factory setting for the refraction coefficient K is 0.142.

Refer to the section 3.10 to change the value of K.

NOTE:

These designs, figures and specifications are subject to change without notice. We shall not be held liable for damages resulting from errors in this instruction manual.