

保密文件
严禁拷贝

受控文件
TRCC

TP-LINK[®]
The Reliable Choice

Easy Wi-Fi Extension Flexible Placement

AC 1200 Wi-Fi Range Extender

RE380D

1910011476

REV 1.0.0

COPYRIGHT & TRADEMARKS

Specifications are subject to change without notice. **TP-LINK**[®] is a registered trademark of TP-LINK TECHNOLOGIES CO., LTD. Other brands and product names are trademarks or registered trademarks of their respective holders.

No part of the specifications may be reproduced in any form or by any means or used to make any derivative such as translation, transformation, or adaptation without permission from TP-LINK TECHNOLOGIES CO., LTD. Copyright ©2015 TP-LINK TECHNOLOGIES CO., LTD.

All rights reserved.

<http://www.tp-link.com>

FCC STATEMENT



This equipment has been tested and found to comply with the limits for a Class B digital device, pursuant to part 15 of the FCC Rules. These limits are designed to provide reasonable protection against harmful interference in a residential installation. This equipment generates, uses and can radiate radio frequency energy and, if not installed and used in accordance with the instructions, may cause harmful interference to radio communications. However, there is no guarantee that interference will not occur in a particular installation. If this equipment does cause harmful interference to radio or television reception, which can be determined by turning the equipment off and on, the user is encouraged to try to correct the interference by one or more of the following measures:

- Reorient or relocate the receiving antenna.
- Increase the separation between the equipment and receiver.
- Connect the equipment into an outlet on a circuit different from that to which the receiver is connected.
- Consult the dealer or an experienced radio/ TV technician for help.

This device complies with part 15 of the FCC Rules. Operation is subject to the following two conditions:

- 1) This device may not cause harmful interference.
- 2) This device must accept any interference received, including interference that may cause undesired operation.

Any changes or modifications not expressly approved by the party responsible for compliance could void the user's authority to operate the equipment.

Note: The manufacturer is not responsible for any radio or tv interference caused by unauthorized modifications to this equipment. Such modifications could void the user's authority to operate the equipment.

FCC RF Radiation Exposure Statement

This equipment complies with FCC RF radiation exposure limits set forth for an uncontrolled environment. This device and its antenna must not be co-located or operating in conjunction with any other antenna or transmitter.

“To comply with FCC RF exposure compliance requirements, this grant is applicable to only Mobile Configurations. The antennas used for this transmitter must be installed to provide a separation distance of at least 20 cm from all persons and must not be co-located or operating in conjunction with any other antenna or transmitter.”

The device operates in 5.15 ~ 5.25GHz frequency range. It is restricted in indoor environment only. This device meets all the other requirements specified in Part 15E, Section 15.407 of the FCC Rules.

CE Mark Warning



This is a class B product. In a domestic environment, this product may cause radio interference, in which case the user may be required to take adequate measures.

RF Exposure Information

This device meets the EU requirements (1999/519/EC) on the limitation of exposure of the general public to electromagnetic fields by way of health protection.

The device complies with RF specifications when the device used at 20 cm from your body.

National Restrictions

This device is intended for home and office use in all EU countries (and other countries following the EU directive 1999/5/EC) without any limitation except for the countries mentioned below:

Country	Restriction	Reason/remark
Belarus	Not implemented	
Norway	Implemented	This subsection does not apply for the geographical area within a radius of 20 km from the centre of Ny-Ålesund on Svalbard.
Italy	Implemented	The public use is subject to general authorisation by the respective service provider.
Russian Federation	Limited implementation	1. SRD with FHSS modulation 1.1. Maximum 2.5 mW e.i.r.p. 1.2. Maximum 100 mW e.i.r.p. Permitted for use SRD for outdoor applications without restriction on installation height only for purposes of gathering telemetry information

for automated monitoring and resources accounting systems. Permitted to use SRD for other purposes for outdoor applications only when the installation height is not exceeding 10 m above the ground surface.

1.3. Maximum 100 mW e.i.r.p. Indoor applications.

2. SRD with DSSS and other than FHSS wideband modulation

2.1. Maximum mean e.i.r.p. density is 2 mW/MHz. Maximum 100 mW e.i.r.p.

2.2. Maximum mean e.i.r.p. density is 20 mW/MHz. Maximum 100 mW e.i.r.p. It is permitted to use SRD for outdoor applications only for purposes of gathering telemetry information for automated monitoring and resources accounting systems or security systems.

2.3. Maximum mean e.i.r.p. density is 10 mW/MHz. Maximum 100 mW e.i.r.p. Indoor applications.

Ukraine	Limited implementation	e.i.r.p. ≤ 100 mW with built-in antenna with amplification factor up to 6 dBi
---------	------------------------	--

ATTENTION: Due to EU law, the country settings must be identical to the country where the device is operating (important due to non-harmonised frequencies in the EU).

Restricted to indoor use.

Canadian Compliance Statement

This device complies with Industry Canada license-exempt RSSs. Operation is subject to the following two conditions:

- 1) This device may not cause interference, and
- 2) This device must accept any interference, including interference that may cause undesired operation of the device.

Le présent appareil est conforme aux CNR d'Industrie Canada applicables aux appareils radio exempts de licence. L'exploitation est autorisée aux deux conditions suivantes :

- 1) l'appareil n' doit pas produire de brouillage, et
- 2) l'utilisateur de l'appareil doit accepter tout brouillage radioélectrique subi, même si le brouillage est susceptible d'en compromettre le fonctionnement.

Caution

The device for operation in the band 5150–5250 MHz is only for indoor use to reduce the potential for harmful interference to co-channel mobile satellite systems.

Avertissement

Le dispositif fonctionnant dans la bande 5150-5250 MHz est réservé uniquement pour une utilisation à l'intérieur afin de réduire les risques de brouillage préjudiciable aux systèmes de satellites mobiles utilisant les mêmes canaux.

Radiation Exposure Statement

This equipment complies with IC radiation exposure limits set forth for an uncontrolled environment. This equipment should be installed and operated with minimum distance 20cm between the radiator & your body.

Déclaration d'exposition aux radiations

Cet équipement est conforme aux limites d'exposition aux rayonnements IC établies pour un environnement non contrôlé. Cet équipement doit être installé et utilisé avec un minimum de 20 cm de distance entre la source de rayonnement et votre corps.

Industry Canada Statement

CAN ICES-3 (B)/NMB-3(B)

Korea Warning Statements

당해 무선설비는 운용중 전파혼신 가능성이 있음.

NCC Notice & BSMI Notice

注意!

依據 低功率電波輻射性電機管理辦法

第十二條 經型式認證合格之低功率射頻電機，非經許可，公司、商號或使用者均不得擅自變更頻率、加大功率或變更原設計之特性或功能。

第十四條 低功率射頻電機之使用不得影響飛航安全及干擾合法通行；經發現

有干擾現象時，應立即停用，並改善至無干擾時方得繼續使用。前項合法通信，指依電信規定作業之無線電信。低功率射頻電機需忍受合法通信或工業、科學以及醫療用電波輻射性電機設備之干擾。

減少電磁波影響，請妥適使用。

安全諮詢及注意事項

- 請使用原裝電源供應器或只能按照本產品注明的電源類型使用本產品。
- 清潔本產品之前請先拔掉電源線。請勿使用液體、噴霧清潔劑或濕布進行清潔。
- 注意防潮，請勿將水或其他液體潑灑到本產品上。
- 插槽與開口供通風使用，以確保本產品的操作可靠並防止過熱，請勿堵塞或覆蓋開口。
- 請勿將本產品置放於靠近熱源的地方。除非有正常的通風，否則不可放在密閉位置中。
- 請不要私自打開機殼，不要嘗試自行維修本產品，請由授權的專業人士進行此項工作。



Продукт сертифіковано згідно с правилами системи УкрСЕПРО на відповідність вимогам нормативних документів та вимогам, що передбачені чинними законодавчими актами України.



Safety Information

- When product has power button, the power button is one of the way to shut off the product; when there is no power button, the only way to completely shut off power is to disconnect the product or the power adapter from the power source.
- Don't disassemble the product, or make repairs yourself. You run the risk of electric shock and voiding the limited warranty. If you need service, please contact us.
- Avoid water and wet locations.
- Adapter shall be installed near the equipment and shall be easily accessible.
- The plug considered as disconnect device of adapter.
-  Use only power supplies which are provided by manufacturer and in the original packing of this product.

This product can be used in the following countries:

AT	BG	BY	CA	CZ	DE	DK	EE
ES	FI	FR	GB	GR	HU	IE	IT
LT	LV	MT	NL	NO	PL	PT	RO
RU	SE	SG	SK	TR	UA	US	

DECLARATION OF CONFORMITY

For the following equipment:

Product Description: **AC1200 Wi-Fi Range Extender**

Model No.: **RE380D**

Trademark: **TP-LINK**

We declare under our own responsibility that the above products satisfy all the technical regulations applicable to the product within the scope of Council Directives:

Directives 1999/5/EC, Directives 2004/108/EC, Directives 2006/95/EC, Directives 1999/519/EC, Directives 2011/65/EU

The above product is in conformity with the following standards or other normative documents

EN 300 328 V1.8.1

EN 301 489-1 V1.9.2 & EN 301 489-17 V2.2.1

EN 55022: 2010 + AC: 2011

EN 55024: 2010

EN 60950-1: 2006 + A11: 2009 + A1: 2010 + A12: 2011 +A2: 2013

EN 50385: 2002

EN 301 893 V1.7.1

The product carries the CE Mark:

CE 1588 

Person responsible for marking this declaration:



Yang Hongliang

Product Manager of International Business

Date of issue: 2015-10-11

Contents

<i>Appearance</i>	1
LED Explanation	1
Button Explanation	2
Positioning the Product	2
Option ONE: Horizontal Installation	2
Option TWO: Vertical Installation	3
<i>Connect the Extender to the Internet</i>	4
Before You Begin	4
Quick Setup	5
Option ONE: Using Web Browser	5
Option TWO: Using WPS (Wi-Fi Protected Setup)	9
Entertainment Adapter	10
<i>View the Information of the Extender</i>	12
View the Extender's Current Status	12
View the Information about the Host Network, the Extender and the Clients	13
<i>Manage the Extended Network and Security Settings</i>	14
Extend another Network	14
Change the Extended SSIDs	16
Manage the Extender's Security Settings	17
Admin Account	17
Access Control to the Extender	17
Change the Extender's IP Address	19
DHCP Server	20
Set the DHCP Server	20
View the DHCP Client List	21
<i>Manage the Extender</i>	22
Time Settings	22
LED Control	22
Firmware Upgrade	23
Backup & Restore	23
Backup Configurations	23
Restore Configurations	24
Factory Default Restore	24
System Log	24
Reboot	25
Logout	25
<i>Appendix</i>	26
Factory Default Settings	26
Troubleshooting	26
Specifications	27
Glossary	28

1



Appearance

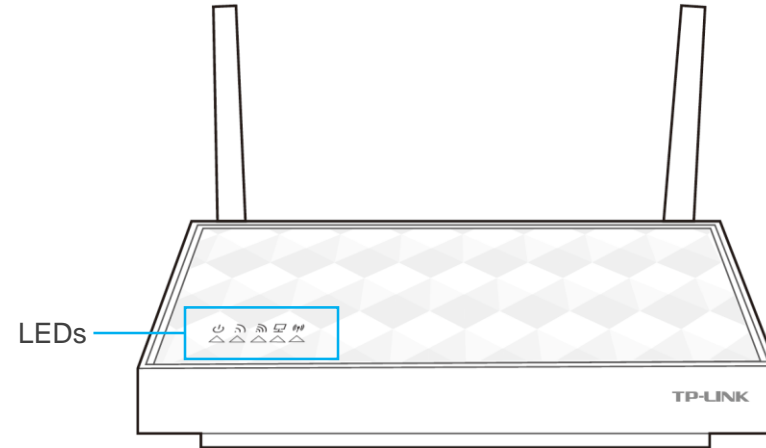

This chapter covers the following topics:

- **LED Explanation**
- **Button Explanation**
- **Positioning the Product**

LED Explanation



Name	Status	Indication
 (RE)	Solid blue	The extender has established a secure connection, and the signal strength is adequate.
	Solid orange	The extender has established a secure connection, but the signal strength is too weak.
	Blinking	WPS connection is in process.
	Off	No active connection.
 (5GHz)/  (2.4GHz)	On	The extender is connected to the 2.4GHz or 5GHz wireless network of your host network.
	Off	No connection.

 (Power)	On	The extender is on.
	Blinking	The extender is initializing.
	Off	The extender is off.
 (Ethernet)	On	The Ethernet port is connected.
	Off	The Ethernet port is not connected.

Button Explanation

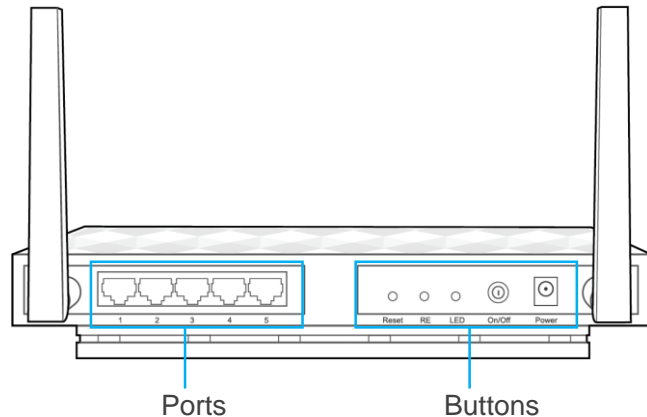

- ◆ **(RE/WPS) Button:** If your Wireless router supports WPS or QSS function, you can press the WPS or QSS button and then press the RE button to establish a secure connection between the Wireless router and the extender.
- ◆ **Reset Button:** This button is used to restore the extender's factory default settings. There are two ways to reset the extender:

Option One: With the extender powered on, use a pin to press the **RESET** button until all the LEDs turn on momentarily, then release the button and wait the extender to reboot to its factory default settings.

Option Two: Restore the default settings from “**System Tools > Backup & Restore**” of the extender's Web-based Management page.

- ◆ **LED Button:** You can press the LED button to light up or turn off all the LEDs. After the LEDs are off, the extender can still work normally.
- ◆ **Power Button :** You can press the Power button to turn on or off the extender.
- ◆ **Ethernet Port:** Five 10/100/1000Mbps RJ45 Ethernet ports used to add wireless connectivity to an Ethernet-enabled device such as Internet TV, DVR, Gaming console and so on. Please note that this port is not allowed to be connected with router.

Positioning the Product

Option ONE: Horizontal Installation

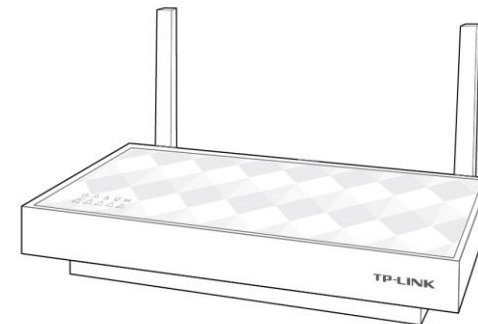

Option TWO: Vertical Installation

Find the provided base support, insert its clips into the slots marked with ▲, then push it leftwards.

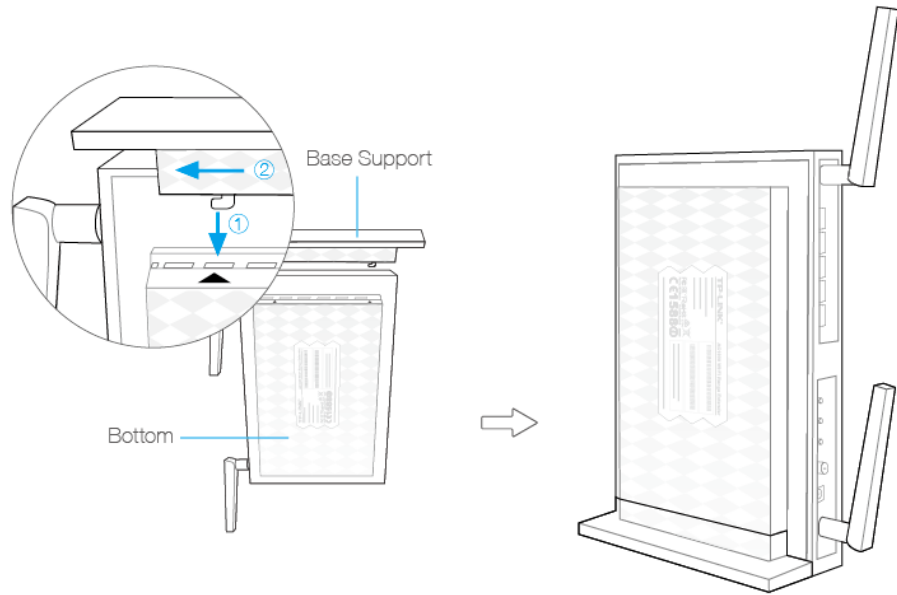

2

Connect the Extender to the Internet

This chapter covers the following topics:

- **Before You Begin**
- **Quick Setup**
- **Entertainment Adapter**

Before You Begin

Please read this chapter carefully before using the device. The operating distance range of your wireless connection can vary significantly depending on the physical position of the wireless devices. Factors that can weaken signals by getting in the way of your network's radio waves are metal appliances or obstructions, and walls. Typical ranges vary based on the types of materials and background RF (radio frequency) noise in your home or office.

In order to optimize the performance of the extender, please follow the instructions below to achieve an **ideal location** (please make sure it is always within the wireless coverage of the wireless router).

- **Half-way Between** - Generally, the ideal location for the extender is half-way between the Wireless router and Wireless Client. If the wireless signal is not satisfactory, you may place the extender somewhat nearer to the Wireless router.

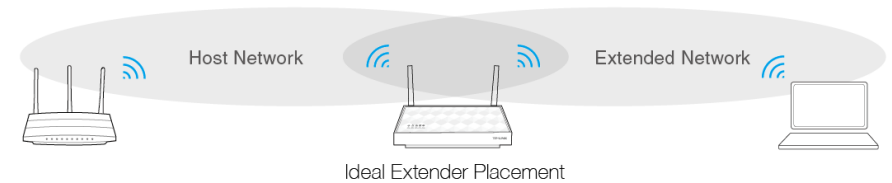

- **No Obstacles and Spacious** - Clear obstacles in the way between the extender and Wireless router. It's better to locate it in a spacious place.
- **No Interference** - Choose a location away from Bluetooth devices and other household electronics, such as cordless phone, microwave, and baby monitor, etc., to minimize signal interference.

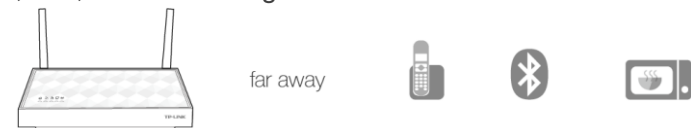

Basic Requirements

- ◆ Place your extender in a well-ventilated place far from direct sunlight, any heater or heating vent.
- ◆ Leave at least 2 inches (5cm) space around the device for heat dissipation.
- ◆ Turn off your extender and unplug the power adapter in a lightning storm to avoid damage.
- ◆ Use Web browser, such as Microsoft Internet Explorer 5.0 or above, Netscape Navigator 6.0 or above.
- ◆ Operating temperature of the extender should be 0°C~40°C (32°F~104°F).
- ◆ Operating humidity of the extender should be 10%~90%RH (Non-condensing).

Quick Setup

Option ONE: Using Web Browser

1 Power On

Plug the extender's adapter into an electrical outlet near your router, then turn on the extender and wait until the Power LED  is lit and solid blue.

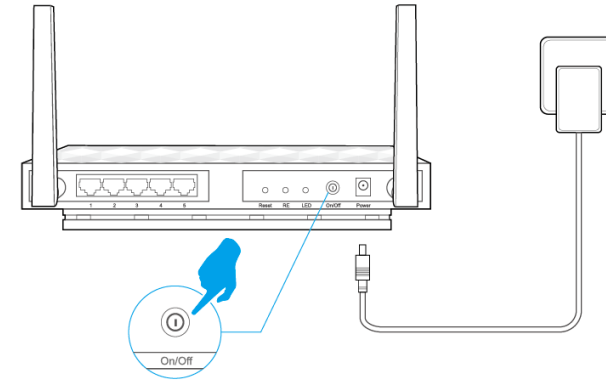

2 Connect to the Extender

• Via Wireless

- 1) Disconnect the Ethernet (wired) connection to your computer.
- 2) Click the Wi-Fi icon on the taskbar and connect to the extender's network (e.g. TP-LINK_Extender_2.4GHz or _5GHz).

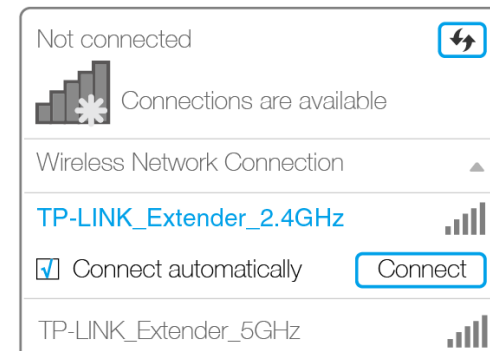

• Via Ethernet Cable

- 1) Disconnect the wireless connection to your computer.

2) Connect the extender to your computer via an Ethernet cable.

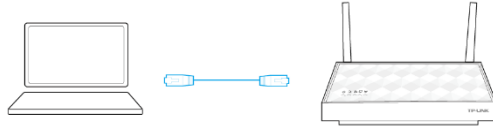

3 Configure

1) Launch a web browser and type **http://tplinkrepeater.net** into the URL field and use **admin** (all lowercase) for both Username and Password to log in.

A screenshot of the login page. It features a green user icon next to a text input field containing 'admin'. Below it is a green key icon next to a password input field with masked characters. A green 'Login' button is positioned below the password field.

2) **Create a new username and password** to log in the web management page, then click **Confirm**.

A screenshot of a dialog box titled 'Create a new username and password.' It contains three input fields: 'New Username:' with the text 'username', 'New Password:' with masked characters and a strength indicator showing 'Low', 'Middle', and 'High' (with 'Middle' highlighted), and 'Confirm Password:' with masked characters and a green checkmark. A green 'Confirm' button is at the bottom right.

3) Select your country/region, then click **Next**.

A screenshot of the wireless settings page. At the top, a progress bar shows four steps: '2.4GHz Host Network', '5GHz Host Network', 'Wireless Settings', and 'Summary'. The 'Wireless Settings' step is active. Below the progress bar, there is a 'Region:' label and a dropdown menu with the text 'Please select your country/region.'. A green 'Exit' button and a grey 'Next' button are at the bottom right.

Per FCC regulations, all Wi-Fi products marketed in the U.S. are fixed to the U.S. region.

A screenshot of the wireless settings page, identical to the previous one, but with 'United States' selected in the 'Region:' dropdown menu. The 'Next' button is now greyed out.

- 4) Select your router's 2.4GHz host network and enter the password, then click **Next**.

Wireless Settings

Region 2.4GHz Host Network 5GHz Host Network Summary

Please select 2.4GHz host network or skip this network.

ID	SSID	Signal	MAC Address	Security
<input checked="" type="radio"/> 1	TP-LINK_841906	📶	00-0A-EB-84-19-05	🔒
<input type="radio"/> 2	CMCC	📶	80-F6-2E-00-F6-21	🔒
<input type="radio"/> 3	CMCC-FREE	📶	80-F6-2E-00-F6-22	🔒
<input type="radio"/> 4	CMCC-WEB	📶	80-F6-2E-00-F6-20	🔒
<input type="radio"/> 5	inadvance	📶	B8-09-8A-B9-34-65	🔒
<input type="radio"/> 6	CMCC-FREE	📶	80-F6-2E-0C-C6-03	🔒
<input type="radio"/> 7	CMCC-WEB	📶	80-F6-2E-0C-C6-00	🔒

Host 2.4GHz Password:

Next

Back **Other...** **Rescan** **Skip**



If you want to connect the extender only to the router's 5GHz wireless network, please click **Skip**.

- 5) Select your router's 5GHz host network and enter the password, then click **Next**.

Wireless Settings

Region 2.4GHz Host Network 5GHz Host Network Summary

Please select 5GHz host network or skip this network.

ID	SSID	Signal	MAC Address	Security
<input checked="" type="radio"/> 1	TP-LINK_841906_5G	📶	40-16-9F-BF-59-15	🔒
<input type="radio"/> 2	TP-LINK_5G_E836	📶	F8-1A-67-2E-E8-36	🔒
<input type="radio"/> 3	TP-LINK_5G_FF67	📶	D8-5D-4C-10-FF-67	🔒
<input type="radio"/> 4	TP-LINK_5116_5G	📶	00-1D-0F-BF-51-15	🔒
<input type="radio"/> 5	TP-LINK_721C_5G	📶	00-0A-EB-AD-72-1B	🔒
<input type="radio"/> 6	TP-LINK_0057_5G	📶	40-16-9F-00-00-59	🔒
<input type="radio"/> 7	TP-LINK_5G_D99E	📶	EC-26-CA-6C-D9-A0	🔒

Host 5GHz Password:

Next

Back **Other...** **Rescan** **Skip**



If your router does not support 5GHz wireless network, please click Skip to continue.

- 6) Either keep the same SSIDs as your host network or create new names for the extended networks, then click **Next**.

2.4GHz Host Network Wireless Settings

Region 5GHz Host Network Summary

Extended 2.4GHz SSID:

Hide SSID broadcast

Note: The extended 2.4GHz password is the same as your Host password.

Extended 5GHz SSID:

Hide SSID broadcast

Note: The extended 5GHz password is the same as your Host password.

- 7) Verify your wireless settings and click **Finish**. The corresponding LEDs (2.4GHz and 5GHz) should turn on and stay solid.

2.4GHz Host Network Wireless Settings

Region 5GHz Host Network Summary

Finish

Router Range Extender

Router

2.4GHz Wireless

SSID: TP-LINK_841906

Password: 80966159

5GHz Wireless

SSID: TP-LINK_841906_5G

Password: 80966159

Range Extender

2.4GHz Wireless

SSID: TP-LINK_841906

Hide SSID: Off

Password: 80966159

5GHz Wireless

SSID: TP-LINK_841906_5G

Hide SSID: Off

Password: 80966159

4 Relocate

- 1) Plug in the extender about halfway between your router (Host Network) and the Wi-Fi dead zone.
- 2) Wait until the (📶) LED is lit with a solid blue. If not, relocate the extender closer to the router to achieve a good (or better) signal quality.

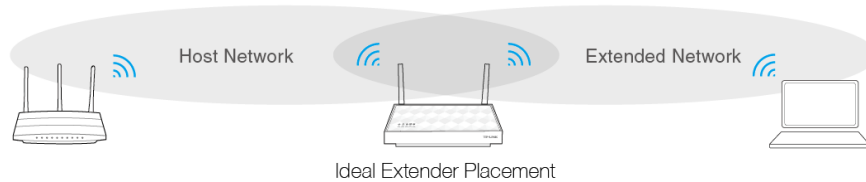

Enjoy!

Both extended networks share the same Wi-Fi password as your main network, but may have different wireless network names if you customize the SSIDs during the configuration.

Option TWO: Using WPS (Wi-Fi Protected Setup)



Your router should support WPS. Otherwise, please use [Option ONE: Using web browser](#).

1 Power On

Plug the extender's adapter into an electrical outlet near your router, then turn on the extender and wait until the Power LED  is lit and solid blue.

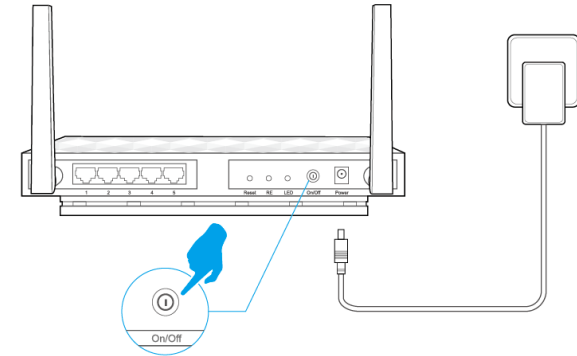

2 Connect

- 1) Press the **WPS button** on your router.

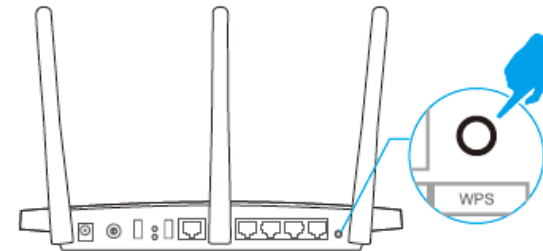

For more information about using WPS on your router, please refer to the router manufacturer's user guide.

- 2) Immediately press the **RE button** on your extender. The (📶) LED should change from blinking to solid, indicating that WPS connection is successful.

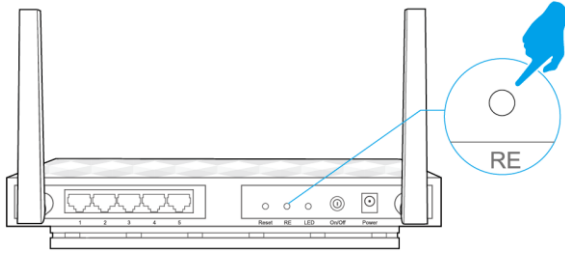

- If the RE LED does not change from blinking to solid, please refer to [Option ONE: Using Web Browser](#).
- Some ISP gateways disable the WPS function by default, if the WPS method fails, please refer to [Using your Web Browser](#).

3) If you are connecting the extender to a dual-band router but only 2.4GHz (📶) or 5GHz (📶) LED is on, repeat step 1) and 2) to connect the other band.

3 Relocate

- 1) Plug the extender into an electrical outlet about halfway between your router (Host Network) and the Wi-Fi dead zone.
- 2) Wait until the (📶) LED is lit with a solid blue. If not, relocate the extender closer to the router to achieve a good (or better) signal quality.

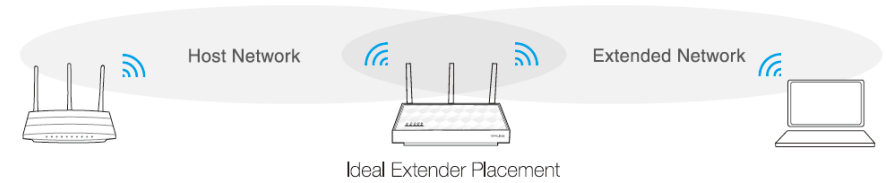

Enjoy!

The extender shares the same wireless network name (SSID) and wireless password as your router.

Entertainment Adapter

The extender can be used as a wireless adapter to connect any Ethernet-enabled device, such as a Blu-ray player, game console, DVR, or smart TV, to your wireless network.

First, connect the extender to your router using Option ONE or Option TWO, then you can connect an Ethernet-enabled device to the extender's Ethernet port using an Ethernet cable.



By default, the Ethernet ports connect to the 5GHz wireless network. If you want your Ethernet-enabled device to connect to the 2.4GHz host wireless network only, please follow the steps below to finish the settings:

- 1) Launch a web browser and log into <http://tplinkrepeater.net>, then go to **Settings > Network** page.

2) Select **2.4GHz** as the following figure shows.

Ethernet Port

Host Network for the Ethernet port: 2.4GHz 5GHz

Save

3) Click **Save** to save the settings.

3

View the Information of the Extender

This chapter covers the following topics:

- **View the Extender's Current Status**
- **View the Information about the Host Network, the Extender and the Clients**

View the Extender's Current Status

- 1) Launch a web browser and log into <http://tplinkrepeater.net>, then go to **Settings > Status** page.
- 2) You can view the network connection in the Status webpage.

- The normal status.

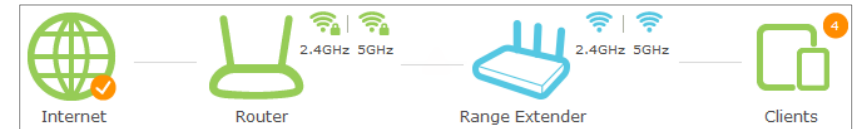

- The extender is failed to connect to your router.

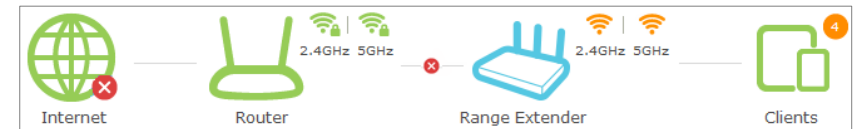

- The extender is connected to your router normally, but no transmitting data. Please check your host network.

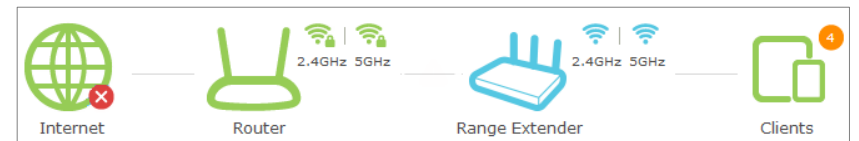

- The extender is connected to the router unnormally. Maybe the gateway is set incorrectly in the Static IP. You can select "Obtain an IP address automatically" on the "Settings > Network" page.

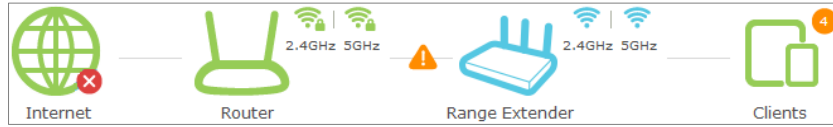

Instructions for the icons of 2.4GHz/5GHz wireless status:

Icon	Instructions
	The wireless is on and encrypted.
	The wireless is on and unencrypted.
	Router: The wireless is off, or the connection is failed. Extender: The wireless is off.
	The icons are selected.

Settings > Status page.

- Click the icons of your router, the extender and clients. The detailed informations of the corresponding icon are displayed below.

The screenshot shows the network status icons at the top, with the Range Extender icon selected. Below the icons, a green header bar reads "Range Extender". The main content area displays the following information:

Extended 2.4GHz		Extended 5GHz	
SSID:	TP-LINK_08B0	SSID:	TP-LINK_08B0_5G
Channel:	2	Channel:	36
MAC Address:	00:0A:EB:13:7B:00	MAC Address:	00:0A:EB:13:7B:02
Wired			
DHCP Server:	Auto (On)		
IP Address:	192.168.0.254		
Type:	Dynamic IP		

View the Information about the Host Network, the Extender and the Clients

- Launch a web browser and log into <http://tplinkrepeater.net>, then go to

4

Manage the Extended Network and Security Settings

This chapter covers the following topics:

- **Extend another Network**
- **Change the Extended SSIDs**
- **Manage the Extender's Security Settings**
- **Change the Extender's IP Address**
- **DHCP Server**

Extend another Network

If you want to extend another network, you can refer to the following steps to finish it quickly.

- 1) Launch a web browser and log into <http://tplinkrepeater.net>, then go to **Settings > Wireless > Connect to Network** page.
- 2) Enable **Connect to 2.4GHz / 5GHz Network**. Then click **Wireless Scanner** to scan the wireless network.

Connect to Host Network

2.4GHz Network: Connect to 2.4GHz Network

Wireless Scanner

Host 2.4GHz SSID:

Host 2.4GHz Security: No Security ▼

Host 2.4GHz Password:

5GHz Network: Connect to 5GHz Network

Wireless Scanner

Host 5GHz SSID:

Host 5GHz Security: No Security ▼

Host 5GHz Password:

Save

3) Select the network you want to extend from the list.

Select a 2.4GHz Host Network Rescan

	ID	SSID	Signal	MAC Address	Security
<input type="radio"/>	1	TP-LINK_08B0		E8:94:F6:FA:08:B0	
<input type="radio"/>	2	TP-LINK_Network		80:F6:2E:0A:A3:60	
<input type="radio"/>	3	TP-LINK_GUEST		80:F6:2E:00:AB:70	
<input type="radio"/>	4	TP-LINK_8B07		00:19:66:CA:8B:07	
<input type="radio"/>	5	hi		94:DE:80:5F:B4:07	
<input type="radio"/>	6	and-Business		80:F6:2E:00:AB:72	
<input type="radio"/>	7	TP-LINK_0E99		80:F6:2E:00:AB:71	
<input type="radio"/>	8	TP-LINK_abcd		FC:D7:33:10:0E:99	
<input type="radio"/>	9	TP-LINK_at12		94:DE:80:6F:B4:07	
<input type="radio"/>	10	TPGuest_2070		02:69:00:27:20:70	

If the network you want to extend is on but not shown in the list, please try the following methods:

- Move the extender closer to your router. Then click **Refresh** on the top-right corner of the list to scan the network again.
- You can also enter the information of the network manually on the **Connect to Network** page. Then click **Save** to connect to the host network.

4) Once a network is selected, the SSID and security settings of that network

will automatically be filled in. If the host network is encrypted, enter the password. And then click **save**.

Connect to Host Network

2.4GHz Network: Connect to 2.4GHz Network Wireless Scanner

Host 2.4GHz SSID: TP-LINK_08B0

Host 2.4GHz Security: WPA-PSK/WPA2-PSK

Host 2.4GHz Password: 12345678

5GHz Network: Connect to 5GHz Network Wireless Scanner

Host 5GHz SSID: TP-LINK_08B0_5G

Host 5GHz Security: WPA-PSK/WPA2-PSK

Host 5GHz Password: 12345678

Save

When **Host 2.4GHz/5GHz Security** is WEP, please select the index same with the host network.

5) **Relocate**

Plug in the extender halfway between your wireless router (Host Network) and the Wi-Fi dead zone.

Wait for the extender to reconnect and the LED turns solid blue. If

not, relocate it closer to the router to achieve a good (or better) signal quality.

Enjoy!

The extender shares the same wireless network name (SSID) and wireless password as your host network. If you want to change the wireless network name (SSID), please refer to [Change the Extended SSIDs](#).

Change the Extended SSIDs

On the Extended Network page, you can enable or disable the wireless network of the extender, change and hide the extender's wireless network names (SSIDs).

- 1) Launch a web browser and log into <http://tplinkrepeater.net>, then go to **Settings > Wireless > Extended Network** page.
- 2) Configure the settings as shown in the figure below.

Extended Network Settings

Extended 2.4GHz: Enable

Extended 2.4GHz SSID: [Copy Host SSID](#)

Hide SSID broadcast

Extended 2.4GHz password is the same as the Host password.

Extended 5GHz: Enable

Extended 5GHz SSID: [Copy Host SSID](#)

Hide SSID broadcast

Extended 5GHz password is the same as the Host password.

[Save](#)

- ◆ **Extended 2.4GHz/5GHz:** Enable or disable the 2.4GHz/5GHz wireless function of the extender.
 - ◆ **Extended 2.4GHz/5GHz SSID:** Either copy the host SSID or create a new name using up to 32 characters. This field is case-sensitive.
 - ◆ **Hide SSID broadcast:** Select this checkbox if you want to hide the extender's SSID from the Wi-Fi network list. If you want to connect to the hidden SSID, please enter the SSID and the password manually.
- 3) Click **Save** to save the settings.

Manage the Extender's Security Settings

Admin Account

- 1) Launch a web browser and log into <http://tplinkrepeater.net>, then go to **Settings > System Tools > Admin Account** page.
- 2) Create a new username and password as shown in the figure below.

Admin Account

Old Username:

Old Password:

New Username:

New Password:

Low Middle High

Confirm Password: ✓

Save

- ◆ **Old Username / Password:** Enter your current username / password.
 - ◆ **New Username / Password:** Enter a new username / password.
 - ◆ **Confirm Password:** Re-enter your new password.
- 3) Click **Save** to save the settings.

Access Control to the Extender

For increased security, you can restrict access to the extender's wireless by allowing only specific Wi-Fi devices in the white list, or blocking the devices that are in the black list from connecting to the wireless network of the extender.

Blacklist Mode

The devices in the Blacklist are not allowed to connect to the extender.

- 1) Launch a web browser and log into <http://tplinkrepeater.net>, then go to **Settings > Wireless > Access Control** page.
- 2) Click the button to enable the Access Control function.

Access Control: On

- 3) Select **Blacklist** as shown in the figure below, then click **Save**.

Access Mode

Default Access Mode: Blacklist Whitelist

Save



- 4) Add the device to the blacklist by following the below ways.

- Add the Online Devices to the blacklist.

In the Online Devices list, you can view the information about the devices connected to the extender. For one device, you can click the

icon  to add the device to the blacklist. For several devices, select them and click **Block** to add them at the same time.

Online Devices



 Refresh  Block

<input type="checkbox"/>	ID	Device Name	IP Address	MAC Address	Connection Type	Modify
<input type="checkbox"/>	1	SophianiPhone77	192.168.0.101	70-14-A6-C7-40-84	Wireless	

- Add the device to the blacklist manually, if the device is not in the Online Devices list.

Click **Add** and enter the device name and MAC address in XX-XX-XX-XX-XX-XX format (e.g. 00-11-22-33-44-AA). And then click **Save**.

Devices in Blacklist

 Add  Delete

<input type="checkbox"/>	ID	Device Name	MAC Address	Modify
--	--	--	--	--

Device Name:

MAC Address:

Whitelist Mode

Only the devices in the Whitelist are allowed to connect to the extender.

- 1) Launch a web browser and log into <http://tplinkrepeater.net>, then go to **Settings > Wireless > Access Control** page.

- 2) Click the button to enable the Access Control function.

Access Control: On



- 3) Select **Whitelist** as shown in the figure below, then click **Save**.

Access Mode

Default Access Mode: Blacklist Whitelist

- 4) Click the **Add** button, and enter the device name and MAC address in XX-XX-XX-XX-XX-XX format (e.g. 00-11-22-33-44-AA). And then click **OK**.

Devices in Whitelist

 Add  Delete





<input type="checkbox"/>	ID	Device Name	MAC Address	Modify
--	--	--	--	--

Device Name:

MAC Address:

Modify or Remove a Device in the Blacklist/Whitelist

- 1) Launch a web browser and log into <http://tplinkrepeater.net>, then go to **Settings > Wireless > Access Control** page.
- 2) You can modify or remove the devices in the Blacklist or Whitelist.

<input type="checkbox"/>	ID	Device Name	MAC Address	Modify
<input type="checkbox"/>	1	my phone	2A-47-56-85-67-10	 
<input type="checkbox"/>	2	host	48-89-11-25-57-95	 

- Modify a Device in the Blacklist or Whitelist: Click the icon , and then enter the device name and MAC address. Click **OK** to save the settings.

Device Name:	<input type="text" value="my phone"/>
MAC Address:	<input type="text" value="2A-47-56-85-67-10"/>
<input type="button" value="Cancel"/> <input type="button" value="OK"/>	

- Remove a Device in the Blacklist or Whitelist: For one device, you can click the icon  to remove the device from the list. For several devices, select them and click **Delete** to remove them at the same time.

Change the Extender's IP Address

By default, the extender is set to obtain an IP address automatically from the host router. If you want to use a specific IP address appropriate to your network demand, please refer to the steps below.



We do NOT recommend you change the IP address unless you are quite sure about the IP setting for special network demand, random changes may lead to Internet disconnection.

- 1) Launch a web browser and log into <http://tplinkrepeater.net>, then go to **Settings > Network** page.
- 2) Select **Use the following IP address**, then enter the IP address and gateway manually.

Network Settings	
	<input type="radio"/> Obtain an IP address automatically
	<input checked="" type="radio"/> Use the following IP address
IP Address:	<input type="text" value="192.168.0.254"/>
Subnet Mask:	<input type="text" value="255.255.255.0"/>
Default Gateway:	<input type="text" value="192.168.0.254"/>
<input type="button" value="Save"/>	

- ◆ **IP Address:** Enter the IP address in dotted-decimal notation (192.168.0.254 by default).

- ◆ **Subnet Mask:** Enter the subnet mask in dotted-decimal notation that determines the size of the network (255.255.255.0 by default).
- ◆ **Default Gateway:** Enter the gateway that is in the same subnet as the IP address in dotted-decimal notation. It is usually the LAN IP address of your router.

3) Click the **Save** button.

DHCP Server

The extender can be configured as a DHCP (Dynamic Host Configuration Protocol) server to assign IP addresses automatically to the clients on the LAN.



To use the extender's DHCP server function, you must set all computers on the LAN to "Obtain an IP Address automatically" .

Set the DHCP Server

- 1) Launch a web browser and log into <http://tplinkrepeater.net>, then go to **Settings > Network** page.
- 2) The DHCP server is set to be auto by default, and the function will automatically be turn on or off according to the DHCP settings of the host network.
 - If you select **on**, please configure it manually.

DHCP Server Settings

DHCP Server: Auto On Off

IP Address Pool: -

Address Lease Time: minutes (1 default, 2880 maximum)

Default Gateway: (Optional)

Primary DNS: (Optional)

Secondary DNS: (Optional)

- ◆ **IP Address Pool:** The start address and end address must be on the same subnet with LAN IP. Your extender will assign addresses within this specified range to its clients.
 - ◆ **Address Lease Time:** The amount of time in which a DHCP client can lease its current dynamic IP address assigned by your extender. After the dynamic IP address expires, the client will be Automatically assigned a new dynamic IP address.
 - ◆ **Default Gateway (Optional):** Enter the LAN IP address of your host router.
 - ◆ **Primary / Secondary DNS (Optional):** Enter the DNS IP address provided by your ISP.
- If you select **Off**, please make sure the DHCP server of your host network is on. Otherwise, you have to set the IP address for each client manually.
- 3) Click **Save** to save your changes.

View the DHCP Client List

The DHCP Client List displays the Client Name, MAC Address, Assigned IP and Lease Time for each DHCP Client connect to the extender.

- 1) Launch a web browser and log into **http://tplinkrepeater.net**, then log in to **Settings > Network** page.
- 2) You can view the information of the DHCP clients connected to the extender in the DHCP Client List.

DHCP Client List				
Total Clients: 1				 Refresh
ID	Client Name	MAC Address	Assigned IP Address	Lease Time
1	admin-PC	74-D4-35-92-30-7E	192.168.0.100	00:00:54

- ◆ **Client Name:** The name of the DHCP client.
- ◆ **MAC Address:** The MAC address of the DHCP client.
- ◆ **Assigned IP Address:** The IP address that is assigned to the client by the DHCP server.
- ◆ **Lease Time:** The time duration that the IP address is leased to the DHCP client.

Click **Refresh** to refresh the DHCP Client List.

5

Manage the Extender

This chapter covers the following topics:

- **Time Settings**
- **LED Control**
- **Firmware Upgrade**
- **Backup & Restore**
- **Factory Default Restore**
- **System Log**
- **Reboot**
- **Logout**

Time Settings

The extender can obtain the current time from the Internet automatically. You can set the time zone at the Time Settings page.

- 1) Launch a web browser and log into **<http://tplinkrepeater.net>**, then log in to **Settings > System Tools > Time Settings** page.
- 2) Select your time zone, and click **Save**.

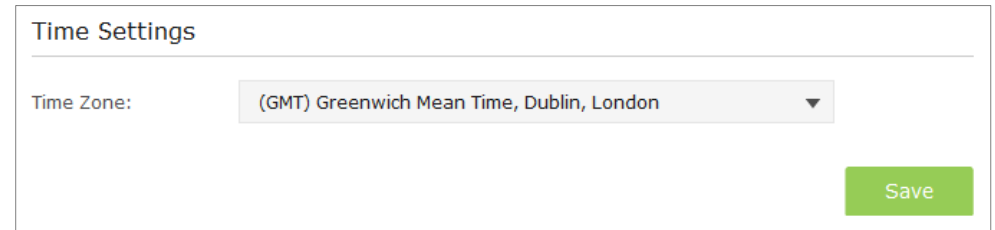

Time Settings

Time Zone: (GMT) Greenwich Mean Time, Dublin, London

Save

LED Control

LED Control can turn off the extender's LEDs at the specific time. The extender can still work normally while the LEDs are off.

- 1) Launch a web browser and log into **<http://tplinkrepeater.net>**, then go to **Settings > System Tools > LED Control** page.
- 2) Tick the **Night Mode** to enable the LED Control function.
- 3) Set the time period to turn off the LEDs.

LED Control

Night Mode

LED Off Time: 21 : 00 - 09 : 00

Note: Before enabling the LED Control, make sure [Time Settings](#) is correct.

Save

- 4) Click **Save** to save your settings.

Firmware Upgrade

- 1) On your computer, download the latest firmware file from our support page at <http://tp-link.com>.
- 2) Launch a web browser and log into <http://tplinkrepeater.net>, then go to **Settings > System Tools > Firmware Upgrade** page.
- 3) Make sure the firmware version you downloaded is same as the hardware version displayed on this page, then click **Browse** to select the downloaded file.

Firmware Upgrade

New Firmware File: **Browse**

Firmware Version: 1.0.0 Build 20150811 Rel. 40166

Hardware Version: RE380D v1.0

Upgrade

- 4) Click **Upgrade**. The upgrade takes a few minutes to complete and the extender will automatically reboot itself when finished.



Please DO NOT power off the extender during the upgrade process.

Backup & Restore

It is highly recommended to backup your current configurations, in case a recovery is needed to restore the system to a previous state or from the factory defaults.

Backup Configurations

- 1) Launch a web browser and log into <http://tplinkrepeater.net>, then go to **Settings > System Tools > Backup & Restore** page.
- 2) Click **Backup** to save your current configurations as a config.bin file on your computer. Make sure to save it in a safe location where you can retrieve it when needed.

Backup

Save a copy of your current settings.

Backup



Please DO NOT power off the extender during the backup process.

Restore Configurations

- 1) Launch a web browser and log into <http://tplinkrepeater.net>, then go to **Settings > System Tools > Backup & Restore** page.
- 2) Click **Browse** to select your backup file. And then click **Restore** restore the extender. The restore process may take a few minutes to complete and the extender will automatically reboot itself when finished.

Restore

Restore saved settings from a file.

File: Browse

Restore



Please DO NOT power off the extender during the restore process.

Factory Default Restore

- 1) Launch a web browser and log into <http://tplinkrepeater.net>, then go to **Settings > System Tools > Backup & Restore** page.
- 2) Click **Factory Default Restore** to reset your extender to its factory default settings.

Factory Default Restore

Revert all settings to factory defaults.

Factory Restore



Factory Restore will erase all settings that you have configured for the extender. To re-login to the extender's management page, use the default **admin** for both username and password.

System Log

System Log can help you know what happened to your extender, facilitating you to locate the malfunctions. For example when your extender does not work properly, you may need to save the system log and send it to the technical support for troubleshooting.

- 1) Launch a web browser and log into <http://tplinkrepeater.net>, then go to **Settings > System Tools > System Log** page.
- 2) You can filter out and view the specific logs by choosing log type and

level.

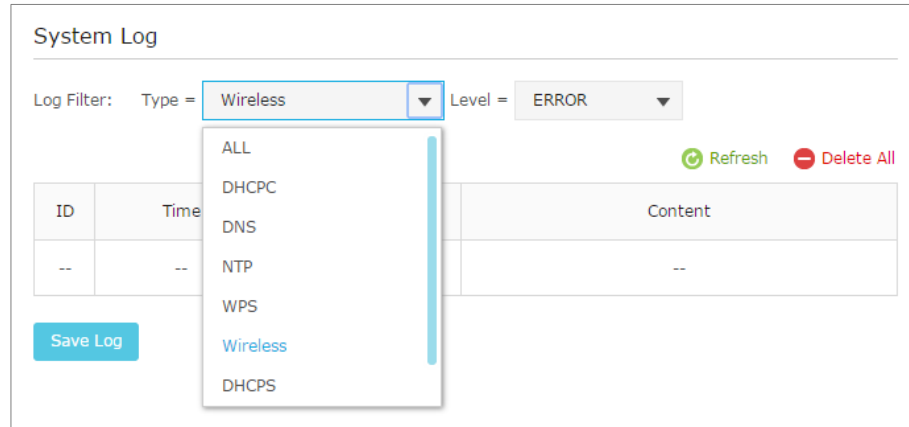

- 3) Click **Save Log** to save all the logs in txt file on your computer.

Reboot

- 1) Launch a web browser and log into **http://tplinkrepeater.net**.
- 2) Click **Reboot** on the top right corner to reboot the extender.

Logout

If you have logged into the web management page **http://tplinkrepeater.net**, click **Logout** on the top right corner to log out safely.

6

Appendix

This chapter covers the following topics:

- **Factory Default Settings**
- **Troubleshooting**
- **Specifications**
- **Glossary**

Factory Default Settings

Name	Status
Username	admin
Password	admin
IP Address	192.168.0.254
Subnet Mask	255.255.255.0
Domain	http://tplinkrepeater.net
Network Name (SSID)	2.4GHz: TP-LINK_Extender_2.4GHz 5GHz: TP-LINK_Extender_5GHz
Wireless Security	Disabled
Access Control	Disabled

Troubleshooting

T1. How do I restore my extender to its factory default settings?

There are two ways to reset the extender:

- Option One: With the extender powered on, use a pin to press and hold the **Reset** button until all LEDs turn on momentarily, then release the

button.

- Option Two: Log into the extender's Web-based Management page, and go to **System Tools > Restore & Backup** page, click **Factory Restore**.



Once the extender is reset, the current settings will be lost and you need to reconfigure it.

T2. What can I do if I forget my login password?

- 1) Restore the extender to its factory default settings. If you don't know how to do that, please refer to previous **T1**;
- 2) Use the default admin for both username and password to log in.
- 3) Reconfigure your extender by following the instructions of this guide.

T3. What can I do if I cannot access the web management page?

- Check to verify all the connections (either wireless or wired ones) are proper. If yes, please proceed to the next step;
- Try to obtain an IP address and gateway; if succeed, open your web-browser, and log into **http://tplinkrepeater.net**. If you are unable to log in, please RESET the device, and then use the default IP address to log into web management page, reconfigure the device.
- Feel free to contact our technical support, if the problem still persists.

T4. How can I know that my wireless signal has been repeated and boosted by the extender?

An easy way is to compare the signal strength of your target wireless network (symbolized by its SSID), with the extender in operation vs. out of

operation. Before comparison, you'd better make sure your computer can obtain an IP address from your target wireless network and thus access the Internet, either via the extender or without.

T5. Will the extender work if I connect the ETHERNET port of it to the router via Ethernet cable?

Sorry, it won't work. The extender is designed to connect wirelessly to the router, while the ETHERNET port is designed to connect with a wired device, like Internet TV, Gaming console, DVR and so on.

T6. Why does the wireless transmission rate speed down, while the wireless signal is stronger after repeated by the extender?

In compliance with the wireless transmission protocol, all the extender devices are set to work in half-duplex instead of full-duplex mode. In other words, the extender has to process one-way communication between your root Wireless router (or AP) and the terminal clients; so the transmission time will be double-increased, while the speed will be decreased. TP-LINK recommends that you connect to the extender when your home network connection is poor, or when you want a larger wireless coverage to eliminate "dead zones".

Specifications

General	
Standards and Protocols	IEEE 802.3, IEEE 802.3u, IEEE 802.11a, IEEE 802.11n, IEEE 802.11b, IEEE 802.11g, IEEE 802.1x, IEEE 802.11e, IEEE 802.11i, IEEE 802.11ac, TCP/IP, DHCP

Safety & Emission	CE
Ports	Five 10/100/1000M Auto-Negotiation LAN RJ45 ports
Wireless	
Frequency Band	2.4GHz: 2.4~2.4835GHz 5GHz: 5.15~5.25GHz
Radio Data Rate	2.4GHz: 11n: up to 300Mbps 11g: 54/48/36/24/18/12/9/6Mbps 11b: 11/5.5/2/1Mbps 5GHz: 11ac: up to 866Mbps 11a: 54/48/36/24/18/12/9/6Mbps
Security	WEP, WPA-PSK, WPA2-PSK
Physical and Environment	
Working Temperature	0°C~40°C (32°F~104°F)
Working Humidity	10% ~ 90% RH, Non-condensing
Storage Temperature	-40°C~70°C (-40°F~158°F)
Storage Humidity	5% ~ 95% RH, Non-condensing

Glossary

- **802.11b** - The 802.11b standard specifies a wireless networking at 11 Mbps using direct-sequence spread-spectrum (DSSS) technology and operating in the unlicensed radio spectrum at 2.4GHz, and WEP encryption for security. 802.11b networks are also referred to as Wi-Fi networks.
- **802.11g** - specification for wireless networking at 54 Mbps using direct-sequence spread-spectrum (DSSS) technology, using OFDM modulation and operating in the unlicensed radio spectrum at 2.4GHz, and backward compatibility with IEEE 802.11b devices, and WEP encryption for security.
- **802.11n** - 802.11n builds upon previous 802.11 standards by adding MIMO (multiple-input multiple-output). MIMO uses multiple transmitter and receiver antennas to allow for increased data throughput via spatial multiplexing and increased range by exploiting the spatial diversity, perhaps through coding schemes like Alamouti coding. The Enhanced Wireless Consortium (EWC) was formed to help accelerate the IEEE 802.11n development process and promote a technology specification for interoperability of next-generation wireless local area networking (WLAN) products.
- **Access Point (Range Extender)** - A wireless LAN transceiver or "base station" that can connect a wired LAN to one or many wireless devices. Access points can also bridge to each other.
- **DNS** (Domain Name System) – An Internet Service that translates the names of websites into IP addresses.
- **Domain Name** - A descriptive name for an address or group of addresses on the Internet.
- **DoS** (Denial of Service) - A hacker attack designed to prevent your computer or network from operating or communicating.
- **DSL** (Digital Subscriber Line) - A technology that allows data to be sent or

received over existing traditional phone lines.

- **ISP** (Internet Service Provider) - A company that provides access to the Internet.
- **MTU (Maximum Transmission Unit)** - The size in bytes of the largest packet that can be transmitted.
- **SSID** - A Service Set Identification is a thirty-two character (maximum) alphanumeric key identifying a wireless local area network. For the wireless devices in a network to communicate with each other, all devices must be configured with the same SSID. This is typically the configuration parameter for a wireless PC card. It corresponds to the ESSID in the wireless Access Point and to the wireless network name.
- **WEP** (Wired Equivalent Privacy) - A data privacy mechanism based on a 64-bit or 128-bit or 152-bit shared key algorithm, as described in the IEEE 802.11 standard.
- **Wi-Fi** - A trademark of the Wi-Fi Alliance and the brand name for products using the IEEE 802.11 family of standards.
- **WLAN** (Wireless Local Area Network) - A group of computers and associated devices communicate with each other wirelessly, which network serving users are limited in a local area.
- **WPA (Wi-Fi Protected Access)** - WPA is a security technology for wireless networks that improves on the authentication and encryption features of WEP (Wired Equivalent Privacy). In fact, WPA was developed by the networking industry in response to the shortcomings of WEP. One of the key technologies behind WPA is the Temporal Key Integrity Protocol (TKIP). TKIP addresses the encryption weaknesses of WEP. Another key component of WPA is built-in authentication that WEP does not offer. With this feature, WPA provides roughly comparable security to VPN tunneling with WEP, with the benefit of easier administration and use. This is similar to 802.1x support and requires a RADIUS server in order to implement. The

Wi-Fi Alliance will call this, WPA-Enterprise. One variation of WPA is called WPA Pre Shared Key or WPA-Personal for short - this provides an authentication alternative to an expensive RADIUS server. WPA-Personal is a simplified but still powerful form of WPA most suitable for home Wi-Fi networking. To use WPA-Personal, a person sets a static key or "passphrase" as with WEP. But, using TKIP, WPA-Personal automatically changes the keys at a preset time interval, making it much more difficult for hackers to find and exploit them. The Wi-Fi Alliance will call this, WPA-Personal.