



# **USER'S MANUAL**

## **MOBILE HIGH BAND VHF RF POWER AMPLIFIER SERIES PA3-1XE**

**3370 N SAN FERNANDO ROAD, #206**

**LOS ANGELES, CA 90065**

**TEL: (323) 256-3000      FAX: (323) 254-321**

**E-Mail: [sales@tplcom.com](mailto:sales@tplcom.com)**

**Web site: [www.tplcom.com](http://www.tplcom.com)**

## **TABLE OF CONTENTS**

- I. PRODUCT DESCRIPTION
- II. GENERAL SPECIFICATION
- III. OPTIONS
- IV. CAUTION
- V. OPERATING PRECAUTIONS
- VI. INSTALLATION
- VII. WARRANTY
- VIII. SERVICE

## I. PRODUCT DESCRIPTION

The PA3-1XE model is a VHF RF power amplifier series intended for use in the mobile applications. This amplifier can deliver RF power from 40 to 125 W when driven with 1 to 50 W (model dependant) and it will cover the frequency range from 136 - 174 MHz. The mobile amplifier is designed to be installed in the interior of a car or in the trunk. The amplifier's dimensions are: 11.6" L x 3.0" H x 5.5" W (see figure 1) and the weight is 5 lbs.

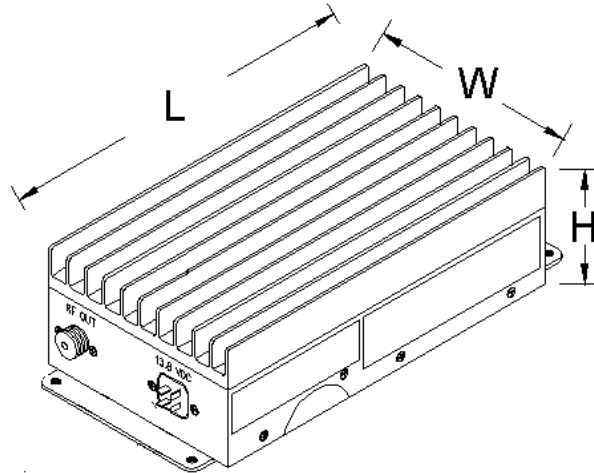

Figure 1. Dimension (D package).

## II. GENERAL SPECIFICATIONS

### ELECTRICAL SPECIFICATIONS @ $V_{DD} = 13.8 \text{ VDC Nom.}$ , $T_A = +25^\circ \text{ C}$

Parameter	Symbol	Min.	Typ.	Max.	Unit	Condition
Frequency Range	BW	136		174	MHz	
Operating bandwidth within range	OBW			38	MHz	
Input Power	$P_{IN}$	1		50	Watt	Model dependant
Output Power	$P_{OUT}$	40	125	130	Watt	See Note 1
Output Flatness	$\Delta P_{OUT}$			$\pm 0.5$	dB	
Gain	G			16	dB	
Duty Cycle	D			40	%	per EIA/TIA-603-C
Harmonic Emissions	Har		-70	-65	dBc	$P_{OUT} = 125 \text{ W}$
Spurious Emissions	Spur		-80	-75	dBc	$P_{OUT} = 125 \text{ W}$
Operating Voltage	$V_{DD}$	11	13.8	15	Volt	
Supply Current	$I_{DD}$		14		Amp	$P_{OUT} = 125 \text{ W}$
Input VSWR	S11		1.3:1	2:1	VSWR	
Operating Mode	Mode	FM/CW				
Emission Designators	ED	F1E, F1D, F1W, F3E, F2D, F7W, FXD, FXE				
Input / Output Impedance	$Z_{IN} / Z_{OUT}$		50		$\Omega$	
Receive Path Insertion Loss	IL		0.5	1	dB	
SSR Attack Time	$t_{ATK}$		100	250	$\mu\text{S}$	

#### ENVIRONMENTAL CHARACTERISTICS

Parameter	Symbol	Min.	Typ.	Max.	Unit	Condition
Operating Temperature	T <sub>O</sub>	-20		+50	°C	
Storage Temperature	T <sub>S</sub>	-40		+85	°C	
Operating Humidity	H <sub>O</sub>	0		85	%	relative, non-condensing
Storage Humidity	H <sub>S</sub>	0		95	%	relative, non-condensing

#### MECHANICAL PROPERTIES

Parameter	Value	Units	Limits	Condition
Dimensions	11.6 L x 3.0 H x 5.5 W	inch	max	
Weight	5	lb	max	
RF Connectors, In/Out	UHF (SO-239)			Type N optional
DC Connector	Cinch 4-pin male			
Cooling	Convection			

#### NOTES:

1. The rated output power of this amplifier is for single carrier operation. For situations when multiple carrier signals are present, the rating would have to be reduced by 3.5 dB, especially when the output signal is re-radiated and can cause interference to adjacent band users. This power reduction is to be by means of input power or gain reduction and not by an attenuator at the output of the device.

#### OPERATING VOLTAGE:

Nominal DC operating voltage is 13.8VDC and the specifications are given at this voltage, as measured at the DC input connector. Reduced DC input voltage will result in lower output power and efficiency.

#### EIA DUTY CYCLE:

**NOTE:** Use of TPL Mobile Amplifiers above the recommended duty cycle or in repeater applications is not recommended and voids the warranty.

#### CONFIGURATION:

All mobile amplifiers are supplied with **Solid State Carrier Operated Relay (SSR)**.

### **III. OPTIONS**

**TPL Communications' VHF Mobile Power Amplifiers** are available with several options: input, output, frequency ranges and configurations, special logos, etc., when specified at the time of order. We work closely with you, our customer, to develop products that are in complete compliance with your needs and specifications.

### **IV. CAUTION**

Inspect the amplifier thoroughly upon receipt for visible damage. If any is noticed, please call **TPL Communications** at **800 HI POWER** to request an **RMA** (Return Material Authorization) number. If purchase through a dealer or distributor, ask them to also follow this procedure for best results.

**EXPENSIVE COMPONENTS MAY BE DESTROYED IF THE AMPLIFIER IS TURNED ON IN A DAMAGE CONDICTION.**

### **FCC CERTIFICATION**

**TPL Communications** commercial amplifiers are FCC and IC certified for the use in Land and Marine mobile/fixed services. The technician installing this amplifier must hold a General Radio Telephone permit and be familiar with the pertinent FCC and IC rules and regulations.

Harmonics, and other spurious, signals from this amplifier are attenuated according to or beyond FCC and IC requirements. For further details consult the appropriate publications.

## V. OPERATING PRECAUTIONS

### CAUTION:

This amplifier produces RF voltages that can cause painful and dangerous burns. Use caution! Connect and disconnect all RF connections with the drive power and DC power off.

### DRIVE POWER:

RF power transistors, although quite rugged in most respects, are easily damaged by overdrive. Be careful not to overdrive the amplifier even momentarily (before applying any drive signal please check table I for details). Higher-than-rated drive power may destroy the transistors and **VOID ANY WARRANTY**.

### SUPPLY VOLTAGE:

The maximum operating voltage is 15VDC. When using the DC power supply make sure that it is not adjusted above 15 volts. If it is possible for the voltage to go above 15 Volts for any reason, including failure of the power supply, install a “crowbar” circuit to prevent damage to the amplifier in the event of excess voltage.

### CASE TEMPERATURE

High power can mean high temperatures. Mount the amplifier where air can freely circulate over it and where clothing, blankets, etc. will not accidentally be placed over it. Keep duty cycle below limits.

### TERMINATIONS

The efficiency of this amplifier will degrade if it is operated into anything but a 50  $\Omega$  load. Lowered efficiency may mean any or all of the following: lower power output, increased current drain, higher operating temperature, and reduced life time.

## **EXPOSURE TO RADIO FREQUENCY ENERGY**

### National and International Standards and Guidelines

Your two-way radio, which generates and radiates radio frequency (RF) electromagnetic energy (EME), is designed to comply with the following national and international standards and guidelines regarding exposure of human beings to radio frequency electromagnetic energy:

Federal Communications Commission Report and Order NO. FCC 96-326 (August 1996)

American National Standards Institute (C95-1-1992)

National Council on Radiation Protection and Measurements (NCRP-1986)

International Commission on Non-Ionizing Radiation Protection (ICNRP - 1986)

European Committee for Electrotechnical Standardization (CENELEC)

Env. 50166 - 1 1995E - Human Exposure to Electromagnetic Fields Low Frequency (0 Hz to 10 kHz)

Env. 50166 - 2 1995E - Human Exposure to Electromagnetic Fields High Frequency (10 kHz to 300 GHz)

Proceedings of SC211/8 1996 - Safety Consideration for Human Exposure to E.M.F's from Mobile Telecommunications Equipment (M.T.E.) in the Frequency Range 30 MHz to 6 GHz (E.M.F. - Electromagnetic Fields)

## **ELECTROMAGNETIC INTERFERENCE/COMPATIBILITY**

NOTE: Nearly every electronics device is susceptible to electromagnetic interference (EMI) if inadequately shielded, designed or otherwise configured for electromagnetic compatibility.

To avoid electromagnetic interference and/or compatibility conflicts, turn off your radio in any facility where posted notices instruct you to do so. Hospitals or

health care facilities may be using equipment that is sensitive to external RF energy.

## **FOR VEHICLES WITH AN AIR BAG**

Do not place a portable radio or amplifier in the area over an air bag or in the air bag deployment area. Air bags inflate with great force. If a portable radio or amplifier is placed in the air bag deployment area and the air bag inflates, the radio or amplifier may be propelled with great force and cause serious injury to occupants of the vehicle.

## **POTENTIALLY EXPLOSIVE ATMOSPHERES**

Turn off your two-way radio when you are in any area with a potentially explosives atmosphere, unless it is a radio type especially qualified for use in such areas (for example, Factory Mutual Approved). Sparks in a potentially explosive atmosphere can cause an explosion or fire resulting in bodily injury or even death.

### **Blasting Caps and Areas**

To avoid possible interference with blasting operations, turn off your radio when you are near electrical blasting caps, in a blasting area, or in areas posted: "Turn off two-way radio". Obey all signs and instructions.

**NOTE:** The areas with potentially explosive atmospheres referred to above include fueling areas such as: below decks on boats: fuel or chemical transfer or storage facilities; areas where the air contains chemicals or particles, such as grain, dust or metal powders; and any other area where you would normally be advised to turn off your vehicle engine. Areas with potentially explosive atmospheres are often but not always posted.

## **MOBILE RADIO OPERATION AND EME EXPOSURE**

To assure optimal radio performance and that human exposure to radio frequency electromagnetic energy is within the guidelines referenced earlier in this document, transmit only when people inside and outside the vehicle are at least the minimum distance away from a properly installed, externally-mounted antenna. For this amplifier that distance is at least two feet.



## Mobile Antenna Installation

Install the vehicle antenna external to the vehicle and in accordance with:

- a) The requirements of the antenna manufacturer/supplier
- b) Instructions in the Radio Installation Manual

## VI. INSTALLATION

The PA3-1XE amplifier installation is illustrated in figure 2. Mount the amplifier as close to the antenna as practical. Keep coaxial cable runs short, avoiding sharp bends and pinching. Avoid loose connectors at the ends of the coaxial cables. The antenna should be matched to an SWR better than 1.5:1 for best results. Higher SWR will degrade the performance of the amplifier.

1. Mount the amplifier away from the sources of heat, and where air can freely circulate around it. Avoid mounting the amplifier in the engine compartment or near the exhaust pipe system.

It is also important to securely fasten the unit. An improperly mounted piece of equipment is subjected to damage as it moves about and can cause serious injuries in an accident. Use bolts through the holes in the amplifiers flange to fasten the unit to a secure mounting surface (see figure 2).

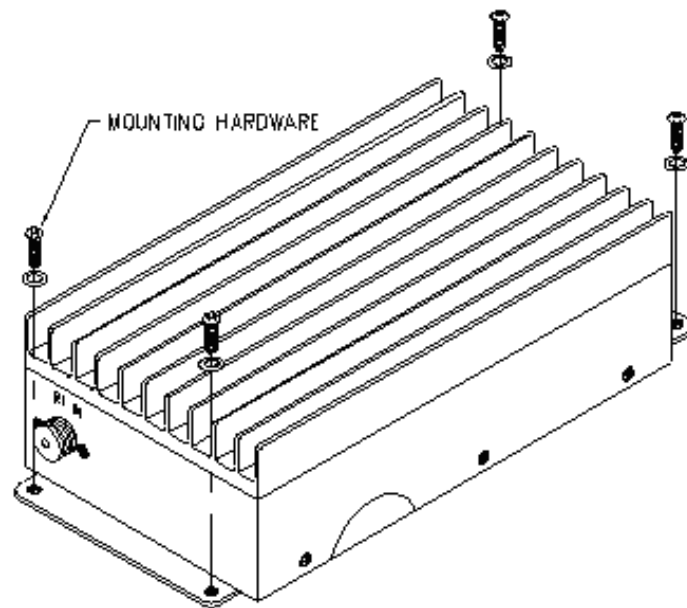

Figure 2. Amplifier installation

2. Wire the DC power connector (Cinch 4 pin female) directly to the battery if possible. Do not use the present vehicle wiring. Use #10 AWG if possible and certainly no lighter than #12 AWG. To avoid a possible fire, or other possible damage, make sure a fuse or circuit breaker is installed at the battery end of the wire. Use the same size as the internal fuse listed in table I.

Attach DC input wires in accordance to the diagram in figure 3. If wires are too large for the holes, solder them to the sides of the blades.

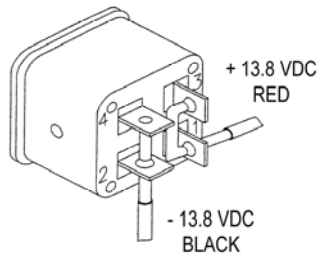

Figure 3. DC connector internal wiring

3. Connect the antenna to the “**RF OUT**” terminal with a 50Ω coaxial cable and a PL-259 male connector according to figure 4.
4. **Turn off** your radio transceiver. **Connect it** to the “**RF INPUT**” terminal with a 50Ω coaxial cable.

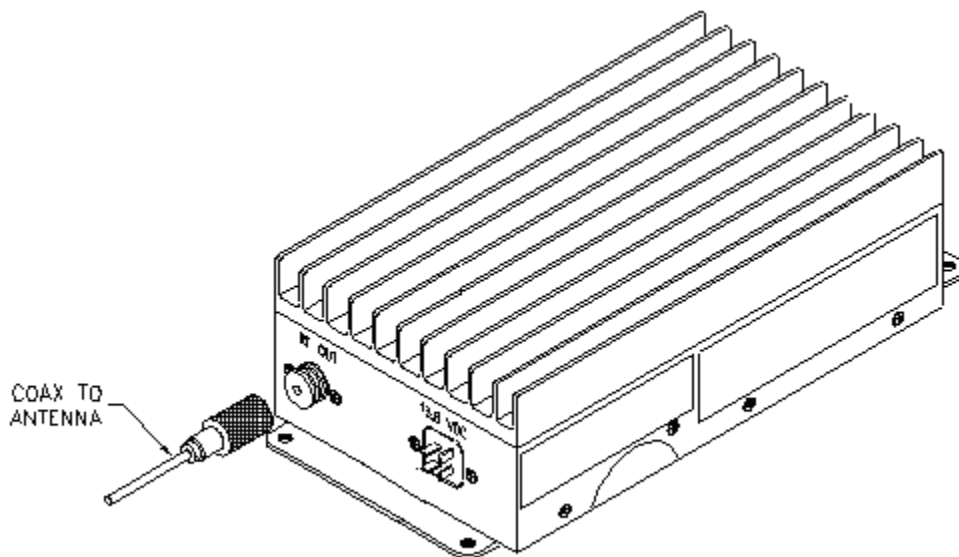
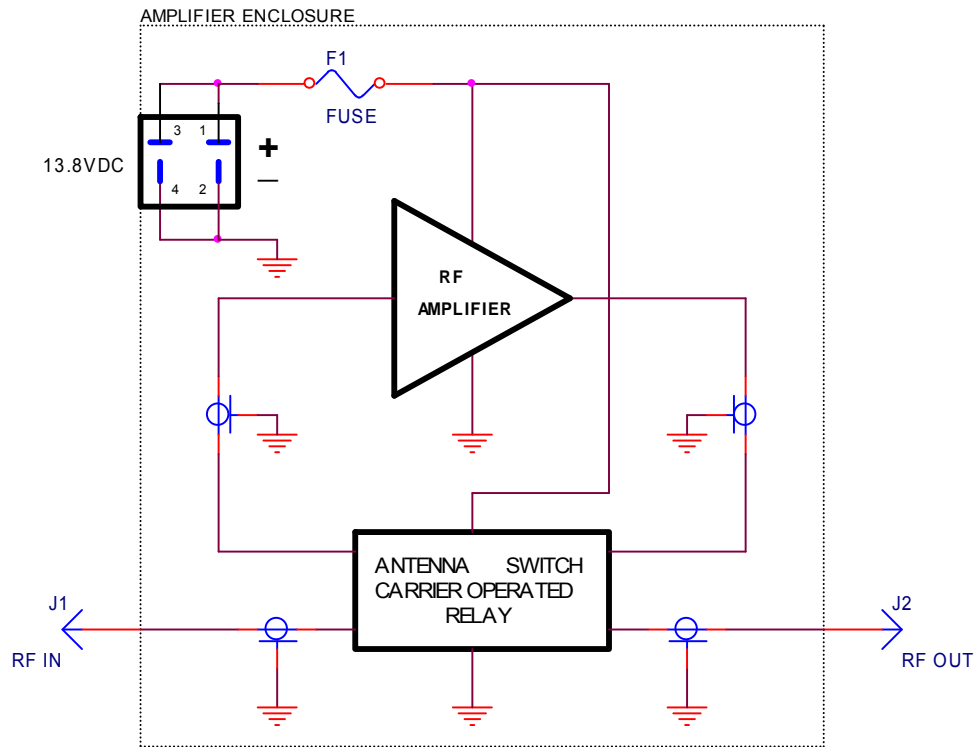

Figure 4. Antenna connection



# MOBILE CONFIGURATION BLOCK DIAGRAM



## **VII. WARRANTY**

**TPL COMMUNICATIONS** has tested and found this unit to function properly and to operate within the parameters of its stated specifications.

**TPL COMMUNICATIONS** warrants that this product is free from defects in material and workmanship. If found to be defective within five (5) years from the date of purchase, the factory will, at its discretion, either repair or replace the unit at no cost, provided the unit is delivered by the owner to the factory intact. The warranty does not apply to any product which has been subjected to misuse, neglect, accident, improper installation or used in violation of the instructions furnished by **TPL**, nor does it extend to units which have been repaired or altered outside our service department, nor where the serial number has been removed, defaced or changed.

## **VIII. SERVICE**

For service on this amplifier, contact:

**TPL COMMUNICATIONS**  
Customer service department  
Phone: (323) 256-3000  
(800) HI POWER  
FAX: (323) 254-3210  
E-MAIL: [tech.support@tplcom.com](mailto:tech.support@tplcom.com)

For information on other  
TPL products visit our web site at:  
[www.tplcom.com](http://www.tplcom.com)