

USER MANUAL

**MOBILE RF
POWER AMPLIFIERS**

**PA3-1AB-M
PA6-1ABL-M
PA6-1ABH-M
PA8-1AA-M**

Leadership by tradition.

TPL
COMMUNICATIONS

L-PAX-1AX-M

GENERAL SPECIFICATIONS MOBILE RF POWER AMPLIFIERS

These amplifiers are provided in four standard communication bands. Specifications which vary for the different bands are as follows:

	PA3-1AB-M	PA6-1ABL-M	PA6-1ABH-M	PA8-1AB-M
	VHF	UHF-L	UHF-H	800 BAND
FREQUENCY RANGE, MHz:				
	136-174	380-470	450-520	806-870
INPUT POWER, Watts:				
	1-6	1-5	1-5	1-3
OUTPUT POWER, Watts:				
	10-50	5-45	7-45	15-25

The following specifications apply to all models:

OPERATING MODE: FM

OPERATING TEMPERATURE RANGE: -30° to +60° Celsius

OPERATING VOLTAGE: Minimum 11 VDC, maximum 16.6 VDC, as measured at the DC input connector. Rated voltage is 13.8 Volts and all specifications are given at 13.8 Volts. Reduced DC voltage will result in a decrease in power output and efficiency.

NOMINAL CURRENT DRAIN: 3-5 Amperes at maximum power and 13.8 VDC. Standby current is less than 10 mA.

DUTY CYCLE: Intermittent (TIA/EIA-603)(Typically 25% max)

NOTE: Using this amplifier at above the recommended duty cycle, or in repeater service, may cause damage and will void the warranty.

RECEIVER PATH LOSS: 1 dB Maximum, over the specified transmit range.

SPURIOUS AND HARMONIC ATTENUATION: Models meet or exceed FCC requirements.

CONNECTORS: Mini UHF on RF input and output. Cinch 4-pin (Male) DC input.

FUSING: An internal 7.5 Ampere fuse is provided. If an external fuse is used, the same value is recommended.

EXPOSURE TO RADIO FREQUENCY ENERGY

National and International
Standards and Guidelines

Your two-way radio, which generates and radiates radio frequency (RF) electromagnetic energy (EME), is designed to comply with the following national and international standards and guidelines regarding exposure of human beings to radio frequency electromagnetic energy:

Federal Communications Commission Report and Order No. FCC 96-326 (August 1996)

American National Standards Institute (C95-1-1992)

National Council on Radiation Protection and Measurements (NCRP - 1986)

International Commission on Non-Ionizing Radiation Protection (ICNRP - 1986)

European Committee for Electrotechnical Standardization
(CENELEC)

Env. 50166 - 1 1995E - Human Exposure to Electromagnetic
Fields Low Frequency (0 Hz to 10kHz)

Env. 50166 - 2 1995E - Human Exposure to Electromagnetic
Fields High Frequency (10kHz to 300GHz)

Proceedings of SC211/8 1996 - Safety Considerations for
Human Exposure to E.M.Fs from Mobile
Telecommunications Equipment (M.T.E.) in the Frequency
Range 30MHz - 6GHz (E.M.F - Electromagnetic Fields)

ELECTROMAGNETIC INTERFERENCE/COMPATIBILITY

NOTE: Nearly every electronic device is susceptible to
electromagnetic interference (EMI) if inadequately shielded,
designed or otherwise configured for electromagnetic
compatibility.

To avoid electromagnetic interference and/or compatibility
conflicts, turn off your radio in any facility where posted notices
instruct you to do so. Hospitals or health care facilities may be
using equipment that is sensitive to external RF energy.

FOR VEHICLES WITH AN AIR BAG

Do not place a portable radio or amplifier in the area over an air
bag or in the air bag deployment area. Air bags inflate with great
force. If a portable radio or amplifier is placed in the air bag
deployment area and the air bag inflates, the radio or amplifier
may be propelled with great force and cause serious injury to
occupants of the vehicle.

POTENTIALLY EXPLOSIVE ATMOSPHERES

Turn off your two-way radio when you are in any area with a
potentially explosive atmosphere, unless it is a radio type
especially qualified for use in such areas (for example, Factory
Mutual Approved). Sparks in a potentially explosive
atmosphere can cause an explosion or fire resulting in bodily
injury or even death.

Blasting Caps and Areas

To avoid possible interference with blasting operations, turn off
your radio when you are near electrical blasting caps, in a
blasting area, or in areas posted: "Turn off two-way radio".
Obey all signs and instructions.

NOTE: The areas with potentially explosive atmospheres
referred to above include fueling areas such as: below decks
on boats; fuel or chemical transfer or storage facilities; areas
where the air contains chemicals or particles, such as grain,
dust or metal powders; and any other area where you would
normally be advised to turn off your vehicle engine. Areas with
potentially explosive atmospheres are often but not always
posted.

Mobile Radio Operation And EME Exposure

To assure optimal radio performance and that human exposure to radio frequency electromagnetic energy is within the guidelines referenced earlier in this document, transmit only when people inside and outside the vehicle are at least the minimum distance away from a properly installed, externally-mounted antenna. For this amplifier, that distance is at least two feet.

Mobile Antenna Installation

Install the vehicle antenna external to the vehicle and in accordance with:

- a) The requirements of the antenna manufacturer/supplier
- b) Instructions in the Radio Installation Manual

NOTE:

These amplifiers have been tuned to the frequencies specified. Adjustment or tuning should not be attempted without reference to a service manual. If required, a service manual is available at the TPL web site listed on page 11.

CAUTION!

Check the amplifier upon receipt for visible damage. If any is noticed, please call TPL at 800 HI POWER to request an RMA number (Return Material Authorization). If purchased through a dealer, ask them to follow this procedure for best results.

EXPENSIVE COMPONENTS MAY BE DESTROYED IF THE AMPLIFIER IS TURNED ON IN A DAMAGED CONDITION.

TYPE ACCEPTANCE

TPL Communications commercial amplifiers are FCC type accepted for use in the Land and Marine mobile/fixed services. The technician installing this amplifier must hold a General Radio Telephone permit and be familiar with the pertinent FCC rules and regulations.

Harmonic, and other spurious, signals from this amplifier are attenuated beyond FCC requirements.

For further details, consult the appropriate publications.

INSTALLATION

Mount the amplifier as close to the antenna as practical. Keep coaxial cable runs short, avoiding sharp bends and pinching. The antenna should be matched to an VSWR of better than 1.2:1 for best results. Higher VSWR will degrade the performance.

Mount the amplifier away from sources of heat, and where air can freely circulate around it. In mobile applications, avoid mounting the amplifier in the engine compartment or near the exhaust pipe or catalytic converter.

In any mobile installation, it is important to securely fasten the unit. An improperly mounted piece of equipment is subject to damage as it moves about and can cause serious injuries in an accident. Use bolts through the holes in the amplifier flange to fasten the unit to a secure mounting surface.

Wire the DC power connector (Cinch 4 pin female), for the amplifier, directly to the battery if possible. Do not use present vehicle wiring. Use #14 AWG if possible and certainly no lighter than #18 AWG. To avoid a possible fire, or other damage, make sure you install a fuse or automotive circuit breaker at the battery end of the wire. Use the same size as the internal fuse listed in the specifications.

Connect the radio transceiver to the "RF INPUT" terminal and the antenna to the "RF OUTPUT" terminal on the amplifier, with 50-ohm coaxial cable and Mini UHF plugs as appropriate. For your convenience, terminating information for the DC connector is given on page 10.

These amplifier produces sufficient power to cause heating of low quality coaxial cable and fittings. Use high quality cables and fittings to reduce heating and keep losses low.

OPERATING PRECAUTIONS

CAUTION: This amplifier produces RF voltages that can cause painful and dangerous RF burns. Use cautions! Connect and disconnect all RF connections with DC power and drive power off.

DRIVE POWER: RF power transistors and modules, although quite rugged in most respects, are easily damaged by overdrive. Be careful not to overdrive this amplifier, even for an instant. Higher than rated drive power may destroy the transistors and **VOID ANY WARRANTY.**

SUPPLY VOLTAGE: The maximum operating voltage is 16.6 Volts. When using an AC power supply, make sure the voltage cannot be adjusted above 16.6 Volts.

CASE TEMPERATURE: High power can mean high temperatures. Mount the amplifier where air can easily circulate over it and where clothing, blankets, etc., will not accidentally be placed over it.

TERMINATIONS: The efficiency of this amplifier will degrade if it is operated into anything but a 50 Ohm load. Lowered output, increased current drain, higher operating temperature, and reduced life may result.

DIAGRAM

DC CONNECTOR WIRING

Attach DC input wires in accordance with this diagram.

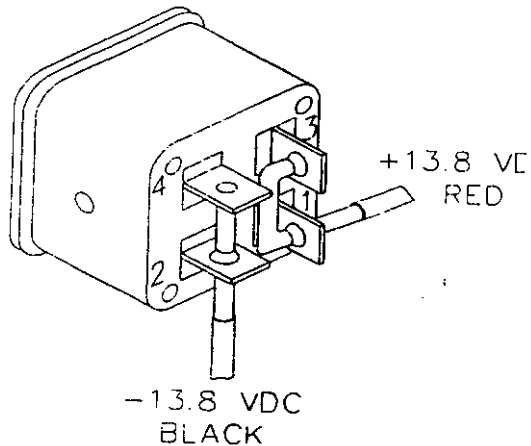

WARRANTY

TPL Communications has tested and found this unit to function properly and to operate within the parameters of its stated specifications.

TPL Communications warrants that this product is free from defects in material and workmanship. If found to be defective within two years from the customer's date of purchase, the manufacturer, at its discretion, will either repair or replace the unit at no cost, provided the unit is delivered by the owner to the manufacturer intact. Warranty does not apply to any product which has been subjected to misuse, neglect, accident, improper installation, or used in violation of instructions furnished by manufacturer; nor does it extend to units which have been repaired or altered outside our service department, or where the serial number has been removed, defaced or changed.

SERVICE

For service on this amplifier, contact:

TPL COMMUNICATIONS
Customer Service Department
PHONE: (323) 256-3000 or (800) HI POWER
FAX: (323) 254 3210

For a complete service manual and further information on these products, visit our Web site at:

www.tplcom.com

APPENDIX B
OPERATING/SERVICE/INSTRUCTION MANUAL