



**USER MANUAL
MOBILE UHF
RF POWER AMPLIFIER
PA6-1AC**

3370 SAN FERNANDO RD., #206
LOS ANGELES, CA 90065
TEL: (323)256-3000 FAX: (323)254-3210
www.tplcom.com

TABLE OF CONTENTS

| | |
|------------------------------|---|
| PRODUCT DESCRIPTION | 2 |
| GENERAL SPECIFICATIONS | 2 |
| OPERATING PRECAUTIONS | 4 |
| INSTALLATION | 5 |
| WARRANTY | 7 |

PRODUCT DESCRIPTION

The PA6-1AC model is a mobile UHF high band RF power amplifier intended for use in the mobile applications. This amplifier can deliver RF power from 10 to 50 W when driven with 1 to 4W and it will cover the frequency range from 400 - 512 MHz. The mobile amplifier is designed to be installed in the interior of a car or in the trunk. The amplifier's dimensions are: 9.5"L x 3.0"H x 4.5" W (see figure 1) and the weight is 4 lbs.

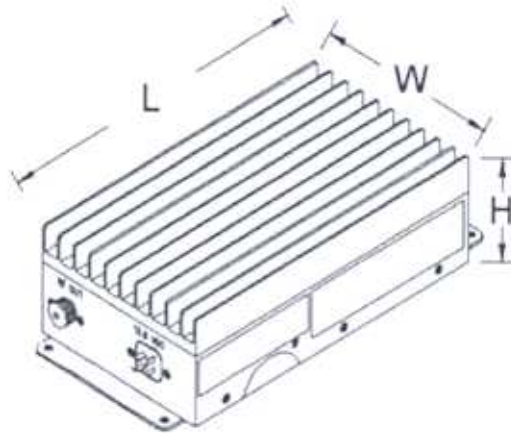

Figure 1. Dimension (C package).

GENERAL SPECIFICATIONS

The general specifications for the PA6-1AC amplifier are shown in this section.

TABLE 1

| MODEL | INPUT POWER | OUTPUT POWER | NOMINAL CURRENT | NOMINAL VOLTAGE | FUSE |
|---------|-------------|--------------|-----------------|-----------------|------|
| PA6-1AC | 1-4 W | 10-50 W | 8A | 13.8 VDC | 15A |

OPERATION MODE: FM / CW

OPERATING VOLTAGE: Nominal DC operating voltage is 13.8VDC and the specifications are given at this voltage. However, the minimum DC operating voltage is 11 Volts and the maximum DC operating voltage is 15 Volts as measured at the VDC input connector. Reduced DC input voltage will result in lower output power and efficiency.

EIA DUTY CYCLE: WITH NO EXTERNAL COOLING:
50 W Output (FM) → 50% duty cycle

NOTE: Use of TPL Mobile Amplifiers above the recommended duty cycle or in repeater applications is not recommended and voids the warranty

GENERAL SPECIFICATIONS

(Continued)

| | |
|--|---|
| HARMONIC AND SPURIOUS ATTENUATION: | Meets or exceeds FCC requirements. |
| IMPEDANCE: | Input: 50Ω. Output: 50 Ω. |
| RF CONNECTORS: | Input: SO-239 (case marked: "RF IN"). Output: SO-239 (case marked: "RF OUT"). |
| DC INPUT CONNECTOR | Cinch 4 pin male (case marked: "13.8VDC"). |
| RECEIVER PATH INSERTION LOSS (400-512 MHz): | 1 dB maximum. |
| CONFIGURATION: | All mobile amplifiers are supplied with solid state Carrier Operated Relay (COR) . |
| OPERATING TEMPERATURE RANGE: | -20 to +50° C / Ambient. |
| STORAGE TEMPERATURE: | -40 to +85° C. |
| OPERATING HUMIDITY: | 0 to 85% RH (non-condensing). |
| STORAGE HUMIDITY: | 0 to 95% RH (non-condensing). |

OPTIONS

TPL Communications' UHF Mobile Power Amplifiers are available with several options: input, output, frequency ranges and configurations, special logos, etc., when specified at the time of order. We work closely with you, our customer, to develop products that are in complete compliance with your needs and specifications.

CAUTION!

Inspect the amplifier thoroughly upon receipt for visible damage. If any is noticed, please call **TPL Communications** at **800 HI-POWER** to request an **RMA** (Return Material Authorization) number. If purchased through a dealer or distributor, ask them to also follow this procedure for best results.

EXPENSIVE COMPONENTS MAY BE DESTROYED IF THE AMPLIFIER IS TURNED ON IN A DAMAGED CONDITION

FCC CERTIFICATION

TPL Communications commercial amplifiers are FCC certified for the use in Land mobile/fixed services. The technician installing this amplifier must hold a General Radio Telephone permit and be familiar with the pertinent FCC rules and regulations.

Harmonics, and other spurious, signals from this amplifier are attenuated according to or beyond FCC requirements. For further details consult the appropriate publications.

OPERATING PRECAUTIONS

CAUTION:

This amplifier produces RF voltages that can cause painful and dangerous burns. Use caution! Connect and disconnect all RF connections with the drive power and DC power off.

DRIVE POWER:

RF power transistors, although quite rugged in most respects, are easily damaged by overdrive. Be careful not to overdrive the amplifier even momentarily (before applying any drive signal please check table I for details). Higher-than-rated drive power may destroy the transistors and **VOID ANY WARRANTY**.

SUPPLY VOLTAGE:

The maximum operating voltage is 15VDC. When using the DC power supply make sure that it is not adjusted above 15 volts. If it is possible for the voltage to go above 15 Volts for any reason, including failure of the power supply, install a "crowbar" circuit to prevent damage to the amplifier in the event of excess voltage.

CASE TEMPERATURE:

High power can mean high temperatures. Mount the amplifier where air can freely circulate over it and where clothing, blankets, etc. will not accidentally be placed over it. Keep duty cycle below limits.

TERMINATIONS:

The efficiency of this amplifier will degrade if it is operated into anything but a 50 Ω load. Lowered efficiency may mean any or all of the following: lower power output, increased current drain, higher operating temperature, and reduced life time.

INSTALLATION

The PA6-1AC amplifier installation is illustrated in figure 2. Mount the amplifier as close to the antenna as practical. Keep coaxial cable runs short, avoiding sharp bends and pinching. Avoid loose connectors at the ends of the coaxial cables. The antenna should be matched to an SWR better than 1.5:1 for best results. Higher SWR will degrade the performance of the amplifier.

1. Mount the amplifier away from the sources of heat, and where air can freely circulate around it. Avoid mounting the amplifier in the engine compartment or near the exhaust pipe system.

It is also important to securely fasten the unit. An improperly mounted piece of equipment is subjected to damage as it moves about and can cause serious injuries in an accident. Use bolts through the holes in the amplifiers flange to fasten the unit to a secure mounting surface (see figure 2).

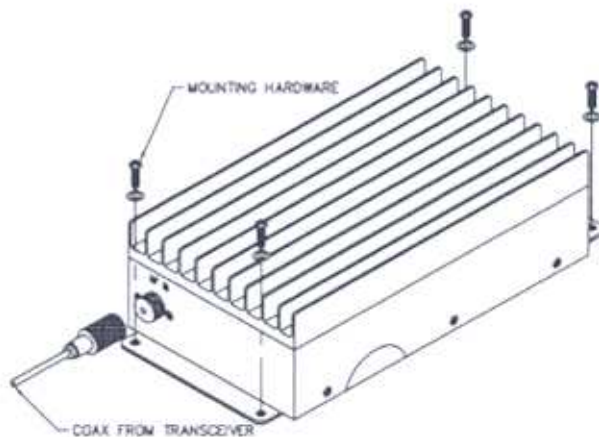

Figure 2. Amplifier installation

2. Wire the DC power connector (Cinch 4 pin female) directly to the battery if possible. Do not use the present vehicle wiring. Use #14 AWG if possible and certainly no lighter than #16 AWG. To avoid a possible fire, or other possible damage, make sure a fuse or circuit breaker is installed at the battery end of the wire. Use the same size as the internal fuse listed in table I.

Attach DC input wires in accordance to the diagram in figure 3. If wires are too large for the holes, solder them to the sides of the blades.

INSTALLATION

(Continued)

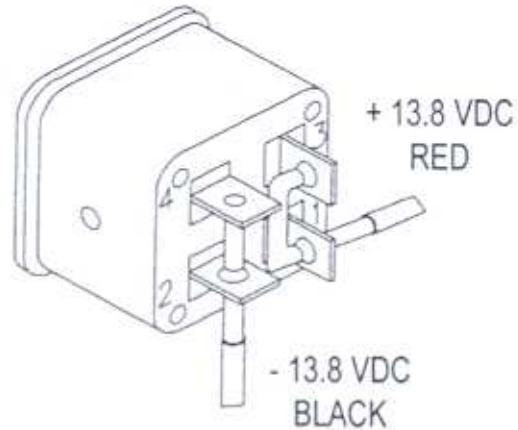

Figure 3. DC connector internal wiring

3. Connect the antenna to the "RF OUT" terminal with a 50 Ω coaxial cable and a PL-259 UHF male connector according to figure 4.
4. **Turn off** your radio transceiver. **Connect it** to the "RF INPUT" terminal with a 50 Ω coaxial cable.

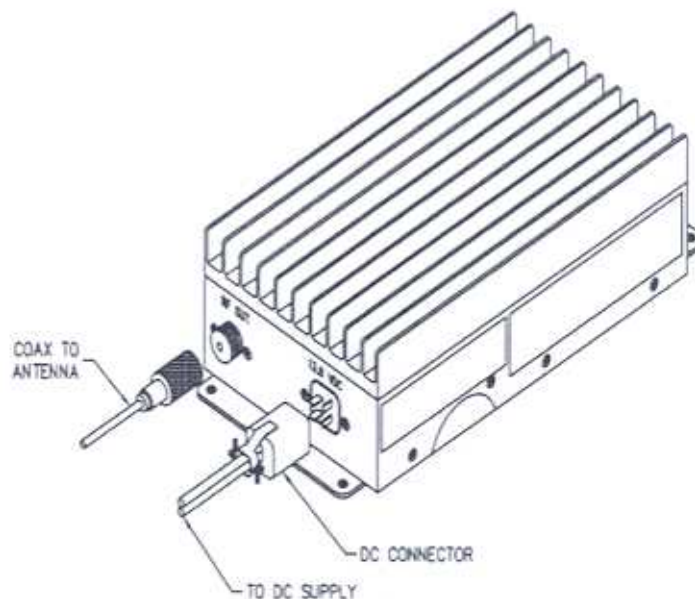

Figure 4. Antenna connection

WARRANTY

TPL COMMUNICATIONS has tested and found this unit to function properly and to operate within the parameters of its stated specifications.

TPL COMMUNICATIONS warrants that this product is free from defects in material and workmanship. If found to be defective within five (5) years from the date of purchase, the factory will, at its discretion, either repair or replace the unit at no cost, provided the unit is delivered by the owner to the factory intact. The warranty does not apply to any product which as been subjected to misuse, neglect, accident, improper installation or used in violation of the instructions furnished by **TPL**, nor does it extend to units which have been repaired or altered outside our service department, nor where the serial number has been removed, defaced or changed.

SERVICE

For service on this amplifier, contact:

TPL COMMUNICATIONS
Customer service department
Phone: (323) 256-3000
(800) HI POWER
FAX: (323) 254-3210
EMAIL: sales@tplcom.com

For information on other
TPL products visit our web site at:
www.tplcom.com