

MANUAL

**KENWOOD KVC-9A
VEHICULAR ADAPTER
VHF AMPLIFIER PO: 30W

KENWOOD CORPORATION**

TPL Communications

SPECIFICATION

KVA Vehicular Adapter

1.0 General Specifications

1.1 This specification defines a mobile radio vehicular adapter which supports a portable radio and gives it most of the functionality of a mobile radio.

1.2 Nomenclature:

This unit is give the abbreviated nomenclature "KVA". KVC-8A indicates a VHF unit for use with the TK-290K portable radio. KVC-9A indicates a UHF unit to be used with the TK-390K radio.

1.2 Compatibility:

The KVA is compatible with and supports at least the following Kenwood radios:

TK-290K, VHF, 150-174 Mhz
TK-290K3, above with keypad
TK-390K, UHF, 450-512 MHz
TK-390K4, above with keypad

1.3 Primary Components:

Main components of the KVA are a mechanical assembly which firmly supports the radio, battery charging contacts, a side connector which makes semi-automatic connection to the side connector of the radios, an automatic fast/trickle charger for the battery, an audio power amplifier, an RF power amplifier and a vehicle mounting bracket.

1.4 Controls:

The following controls are accessed on the front of the unit:

POWER ON/OFF
MONITOR (Access to PF function)
AUX (access to second PF function)
REPEAT
Connector Control Lever
Key Pad (on radio)

1.5 Indicators:

The POWER and REPEAT push buttons are LED illuminated. In addition another LED indicates Rapid/Trickle Charge mode.

1.6 In/Out Connectors:

Connectors are provided for DC power input, Accessory connector, RF In/Out, and microphone.

Rev. C

2.0 Physical Characteristics

- 2.1 Dimensions are 7.0" high by 5.25" wide by 2.8" deep.
- 2.2 Weight is 3.0 lbs.
- 2.3 The unit is configurable for either vertical or horizontal mounting by change of a decal which defines control functions. The mounting bracket is adaptable for either orientation.
- 2.4 Radio connection: Connections to the radio battery are made automatically when it is inserted into the pocket. Side connections are made when a single lever is moved laterally. A press on the lever releases the radio. A tapered pin is installed into the side connector of the radio to accurately index the sliding connector.
- 2.5 Ruggedness: The unit is designed to be very rugged so as to provide an acceptable level of crash safety in the mobile vehicular environment.

3.0 Battery Charging

- 3.1 The unit provides "intelligent" charging controls with the following characteristics:
 - 3.1.1 The rapid charge rate is 500 mA or higher which will, for example, charge a fully discharged 1.0 AH battery in approximately 2.5 hours.
 - 3.1.2 The trickle charge rate is typically 40 mA.
 - 3.1.3 The charger uses a digitally controlled negative Delta V charging algorithm.
 - 3.1.4 The charger first assesses battery status. If battery voltage is too low, a trickle rate is applied until voltage rises to an acceptable level. If voltage or temperature is too high, rapid charge will not commence until this condition is corrected. If temperature is too low, trickle rate is applied until temperature becomes acceptable. A timer will cut off rapid charge if other parameters should fail to do so.
 - 3.1.5 The charger automatically senses whether a battery is in the pocket.
- 3.2 Controller: Charging is controlled by an integrated circuit incorporating the above functions. It also controls a very efficient switching regulator for low dissipation. The charging is done by constant current control.
- 3.3 Charge Indicator: Charge state monitoring is provided by an LED with Off or On states and Red/Green colors which indicate charge and battery status.
- 3.4 Charging Control: An ignition sense function is provided to enable or disable the charging function.

4.0 Battery and Radio Compatibility

- 4.1 The KVA is compatible with the KNB-17A battery or other of the same size.
- 4.2 The KVA is compatible with the radio when a belt clip is attached.
- 4.3 The keypad and display are accessible when the radio is inserted.

5.0 Keylock

- 5.1 A key lock is incorporated to provide radio security.

6.0 Microphone

- 6.1 The unit provides compatibility with the Kenwood model KMC-27B microphone.
- 6.2 An RJ type connector with 8 pins is provided for microphone compatibility.

7.0 Accessory Connector

- 7.1 This connector accommodates various functions including remote speaker, ignition sense, repeater control, and switched B+.

8.0 RF Connector: A UHF female connector is provided for connection to an antenna.

9.0 Universal Connector

- 9.1 Electrical compatibility is provided with the various functions available at this connector, including the switched RF connection.
- 9.2 The KVA uses the Kenwood supplied microphone connector parts kit W01-0438-05 to insure mechanical compatibility.

10.0 RF Amplifier:

An amplifier is provided internally to the KVA. See Appendices A and B for detailed specifications. General characteristics are as follows:

- 10.1 The amplifier covers the same frequency band as the radio specified. The KVC-8A covers the VHF band as does the TK-290K radio (150-174 MHz). The KVC-9A covers the UHF band corresponding to the TK-390K radio (450-512 MHz).
- 10.2 The VHF version uses the 1 to 5W output from the TK-290K. The UHF version uses the 1- 4W drive as provided by the TK-390K.
- 10.3 The amplifier operates within TIA/EIA and FCC specifications. Harmonics and spurious outputs are suppressed by more than 63 dBC.
- 10.4 The unit provides PIN diode solid state switching for receive mode bypass. Insertion loss in this mode is 1 dB maximum.
- 10.5 Nominal power output at VHF is 35 watts. At UHF it is 25 watts.

11.0 Audio Amplifier

- 11.1 An audio amplifier is provided. It is designed to be electrically compatible with the audio output from the radio and with the KES-4 remote speaker.
- 11.2 The amplifier shall produce at least 5 watts at maximum 5% distortion.
- 11.3 Loudness from the speaker is controlled by the volume control of the radio.

11.0 General Specifications:

- 11.1 Supply voltage: 13.8 VDC nominal, +/- 15%.
- 11.2 Standby current drain: 10.0 mA maximum, off state; 100 mA, on state.
- 11.2 RF Impedance: 50 ohms
- 11.3 Operating temperature: - 30 to + 60 degrees C.
- 11.4 Current consumption, Transmit Mode: 6.0 Amps typical, 8.0 Amps maximum.

12.0 Options: The following options are supplied with the KVA product package:

12.1 The KVA Vehicular Adapter

12.2 DC Supply cable

12.2 Accessory Connector with Ignition Sense jumper installed

12.3 Mounting bracket with hex head attachment screws

12.4 A user manual containing installation, operating instructions, and warranty, with content provided by Kenwood with appropriate inputs from TPL.

13.0 Product Appearance

13.1 The paint finish shall be semi-gloss black with light texture using powder coat.

13.2 Trim colors shall be silver gray and white or as otherwise approved.

13.3 The Kenwood logo and model number will be provide and located as specified.

13.4 A rear label is provided with content approved by Kenwood.

**VHF RF POWER AMPLIFIER
SPECIFICATION**

APPENDIX A

CONDITIONS:

TEMPERATURE: -30°C TO +60°C, 13.8 VDC, except as noted.

ALLOW -3dB degradation on Power Output at -30°C and 11.0 VDC input.

Maximum Duty Cycle transmit is 25%.

PARAMETER	MIN	TYP.	MAX	CONDITION	METHOD OF MEASUREMENT
Frequency Range	150 MHz	n/a	174 MHz	n/a	n/a
Voltage Range	11.0V	13.8V	16.6V		
Standby Current drain	n/a	n/a	1 mA	No TX or RX	Current through DC line
Transit current drain	n/a	6A	8A	5W input	Current through DC line
Receive path attenuation	n/a	0.7dB	1dB	n/a	From Antenna port to Radio port.
Carrier Output Pwr. @ 5W input	30W	35W	50W	5W input	See conditions
Carrier Output Pwr. @ 1W input	10W	20W	35W	1W input	See conditions
Radiated Spurious emission	n/a	n/a	-60dBc	n/a	n/a
Conducted Spurious emission	n/a	n/a	-60dBc	n/a	n/a
Amplifier stability into VSWR		n/a	-60dBC	3:1	n/a
Reflected Power	n/a	200mW	400mW	5W input	n/a
Input/Output Impedance	n/a	50 Ohm	n/a	150-174 MHz	n/a

03/13/00

VHFRFPWRAMPSPEC150.doc

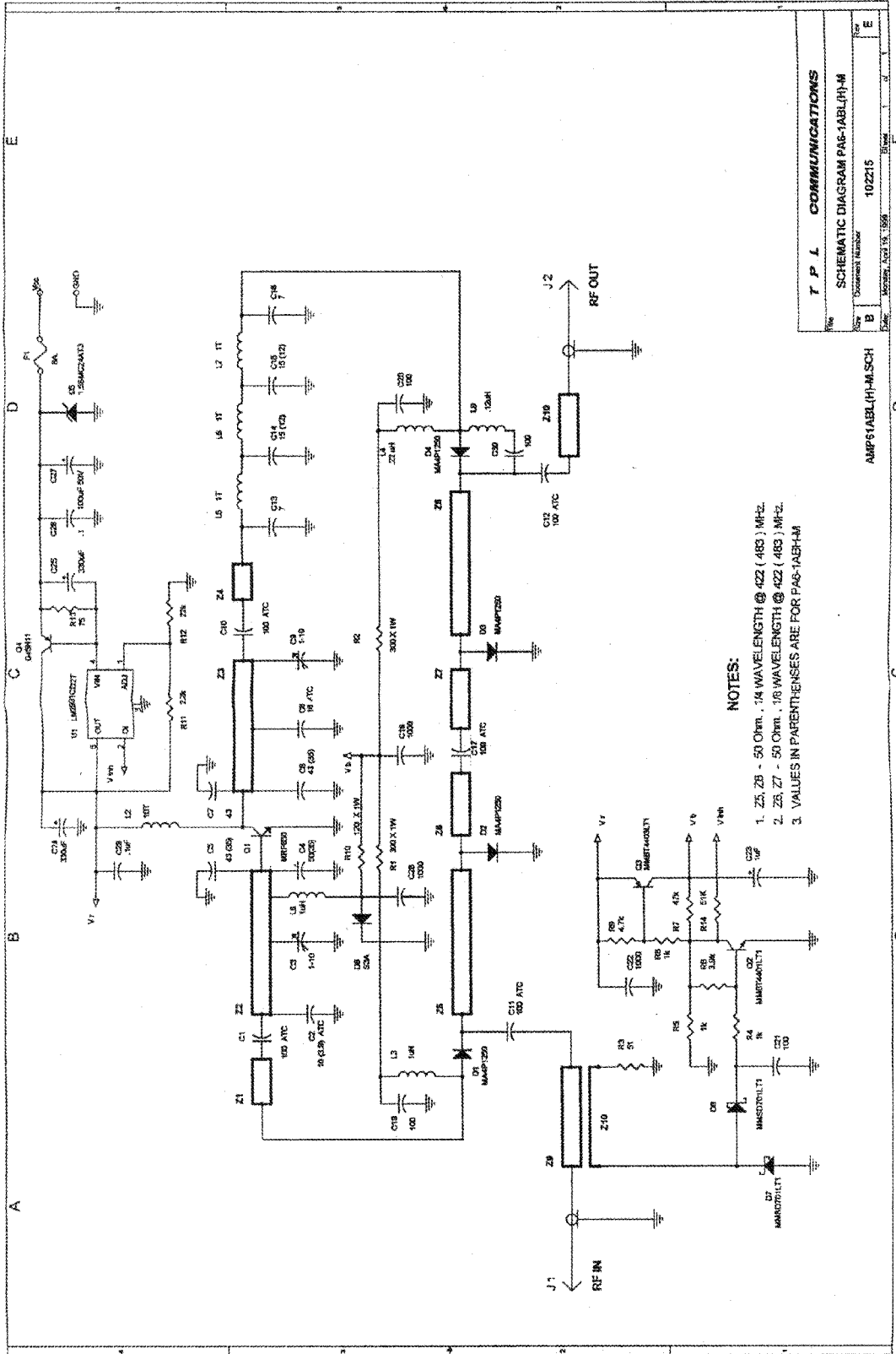

File	T P L COMMUNICATIONS
Document Number	102215
Date	Monday, April 19, 1999
Page	1 of 1

AMP 61ABL(H)-MILSCH

NOTES:

1. Z5, Z6 - 50 Ohm, 14 WAVELENGTH @ 422 (463) MHz.
2. Z5, Z7 - 50 Ohm, 18 WAVELENGTH @ 422 (463) MHz.
3. VALUES IN PARENTHESES ARE FOR PA6-1ABH-M

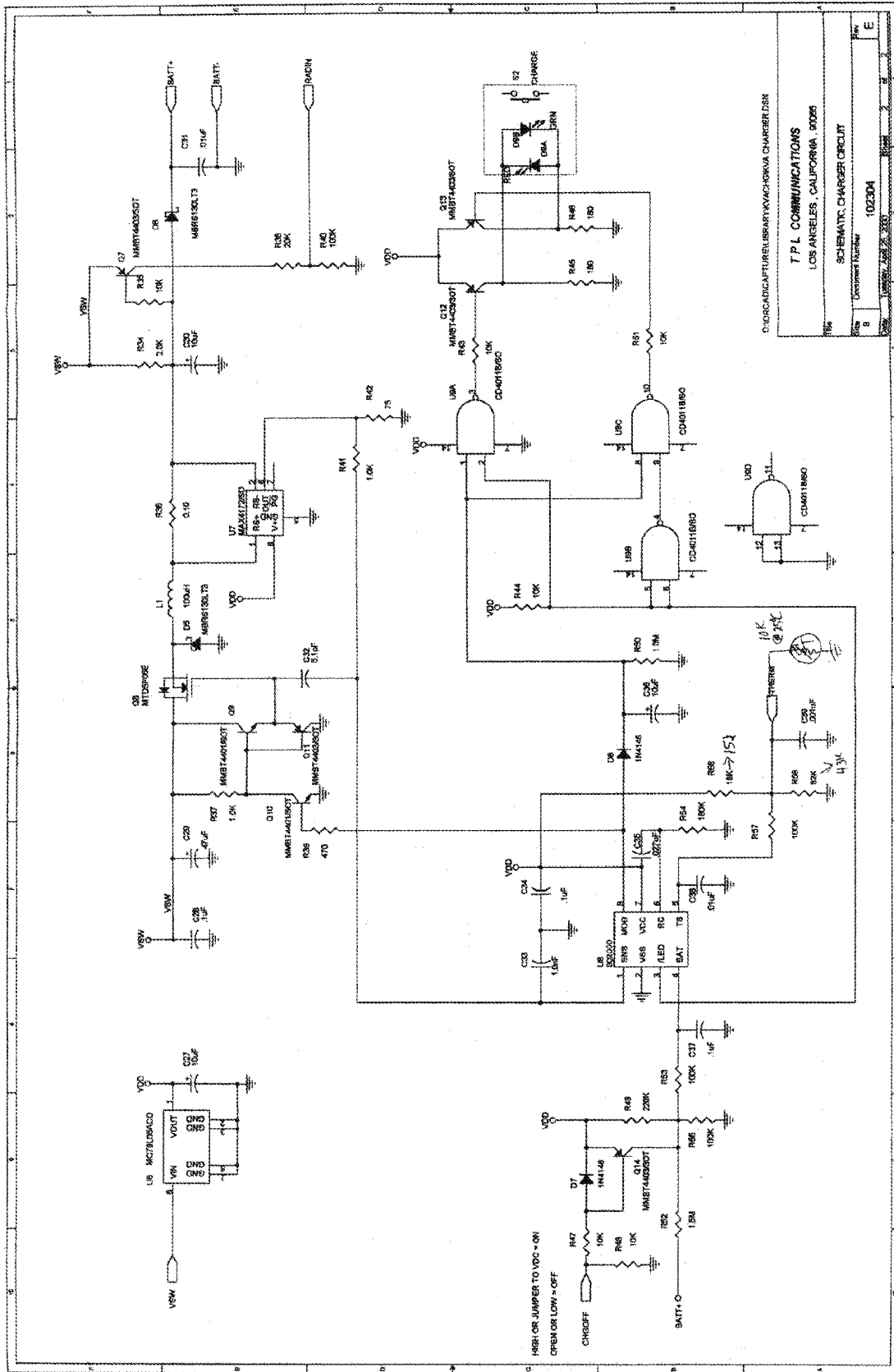

© 1998 CALIFORNIA ELECTRONIC INDUSTRIES, INC. ALL RIGHTS RESERVED.
 T. P. L. COMMUNICATIONS
 LOS ANGELES, CALIFORNIA 90008
 Document Number: 102304
 Rev: B

Micro-U=U=U=

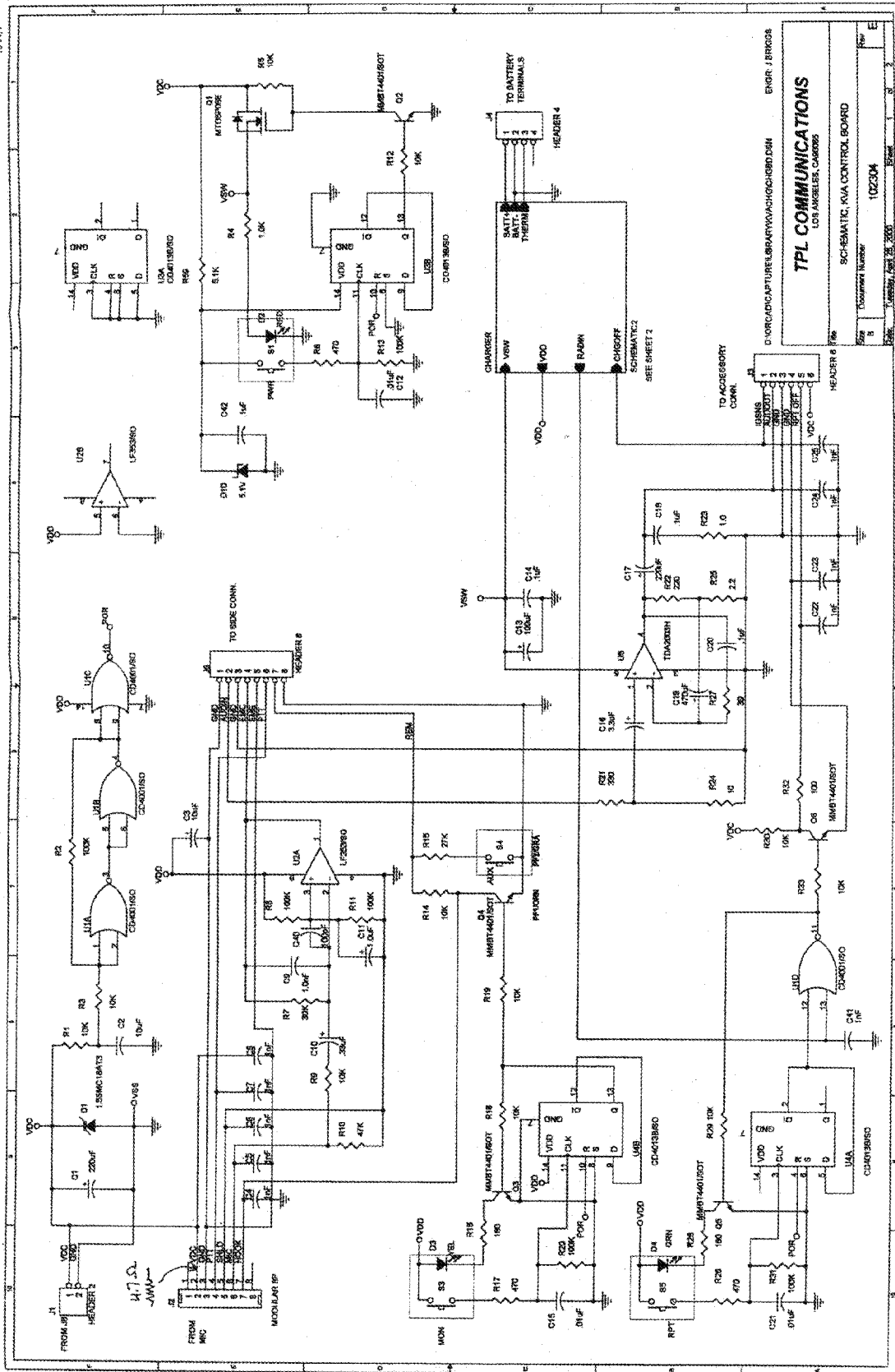

D:\Orcad\CAPTURE\LIBRARY\CHGBD2\ChgCont\chgbd.bom

1: KVA CONTROL BOARD
 2: 102254/BOM SCHEMATIC : 102304D
 3: Tuesday, October 26, 1999 Revised: April 25, 2000
 4:
 5: TEL COMMUNICATIONS
 6: LOS ANGELES, CA90065
 7:
 8: Bill Of Materials
 9:

Page 1 of 2

10: Item	Quantity	Reference	Descript.	Value	Size	P/N	Mfg.
11:							
12:							
13:	1	C1	ELEC CAP	220uF/35V		A2-203	
14:	7	C14,C18,C20,C42	CER CAP	.1uF	~		
15:		C28,C34,C37					
16:	5	C2,C3,C27,C30,C36	ELEC CAP	10uF/35V		NACE100M35V5X5.5	
17:	4	C4,C5,C6,C7,C8,C22,	CER CAP	1nF	~		
18:		C23,C24,C25,C33,C39,C41					
19:	5	C9	CER CAP	1.0nF	~		
20:	6	C10	ELEC CAP	.33uF/50V		NACER3350V4X5.5	
21:	7	C11	ELEC CAP	1.0uF/50V		NACEW1ROM50V4X5.5	
22:	8	C12,C15,C21,C31,C38	CER CAP	.01uF	~		
23:	9	C13	ELEC CAP	100uF/16V		NACE101M16V6.3X5.5	
24:	10	C16	ELEC CAP	3.3uF/50V		NACE3R3M50V4X5.5	
25:	11	C17	ELEC CAP	220uF/16V		NACE221M16V6.3X8	
26:	12	C19	ELEC CAP	330uF/6.3V		NACE331M6.3V6.3X8	
27:	13	C29	ELEC CAP	47uF/50V		NACE470M50V6.3X8	
28:	14	C32	CER CAP	5.1pF	~		
29:	15	C35	CER CAP	.027uF	1210		
30:	17	C40	CER CAP	100pF	~		
31:	18	D1	TRANSORB			1.5SMC18AT3 Mot	
32:	19	D2	RED LED,T1			(in S1)	
33:	20						
34:	21	D4	GRN LED,T1			(in S5)	
35:	22	D9AB	BICOLOR,T1			(in S2)	
36:	23	D5,D6	SCHOTKY			MBRS130LT3 Mot	
37:	23	D7,D8	DIODE			1N4148,SM equiv.	
38:	25	D10	DIODE, ZENER			CMPZ5231B	
39:	26	J1	HEADER 2			53253-0210 MOLEX	
40:	27	J2	MODULAR 8P			GM-SMT-S-88 KYCON	
41:	28	J3	HEADER 6			53253-0610 MOLEX	
42:	29	J4	HEADER 4			53253-0410 MOLEX	
43:	30	J6	HEADER 8			53253-0810 MOLEX	
44:	31	L1	INDUCTOR	100uH		DO3316P-104 Coilcraft	
45:	32	Q1,Q8	FET TRANS			MTD5P06E	
46:	33	Q2,Q3,Q4,Q5,Q6,Q9,Q10	TRANS NPN			MMBT4401	
47:	34	Q7,Q11,Q12,Q13,Q14	TRANS PNP			MMBT4403	
48:	35	R1,R3,R5,R9,R12,	RES	10K	~		
49:		R14,R18,R19,R29,R30,					
50:		R33,R35,R43,R44,					
51:		R47,R48,R51					
52:	36	R2,R6,R11,R13,R20	RES	100K	~		
53:		R31,R40,R53,R55,R57					
54:	37	R4,R37,R41	RES	1.0K	~		
55:	38	R7	RES	30K	~		
56:	39	R10	RES	47K	~		
57:	40	R15	RES	27K	~		
58:	41	R16,R26,R45,R46	RES	180	~		
59:	42	R21	RES	330	~		
60:	43	R32	RES	100	~		
61:	44	R22	RES	220	~		
62:	45	R23	RES	1	~		
63:	46	R24	RES	10	~		
64:	47	R25	RES	2.2	~		
65:	48	R27	RES	.39	~		
66:	49	R34	RES	2.0K	~		
67:							
68:							
69:							
70:							
71:							

D:\Oread\CAPTURE\LIBRARY\CHGBD2\ChgCont\chgbd.bom

72:									
73:	50	1	R36	RES	0.10	1220	RL1220SR10F	GARRET/TFT	
74:	51	1	R38	RES	20K	~			
75:	52	4	R8, R17, R28, R39	RES	470	~			
76:	53	1	R42	RES	75	~			
77:	54	1	R49	RES	220K	~			
78:	55	1	R50	RES	1.0M	~			
79:	56	1	R52	RES	1.5M	~			
80:	57	1	R54	RES	180K	~			
81:	58	1	R56	RES	18K	~			
82:	59	1	R58	RES	82K	~			
83:	60	1	R59	RES	5.1K	~			
84:	61	1	S1 PWR	PB SW	RED	-	97-350.037 +	97-951.2 EAO	
85:	62	1	S2 CHARGE	PB SW	BICOLOR	-	97-081.007 +	97-951.9 EAO	
86:	63	1	S3 MON	PB SW	YEL,NO LED	-	97-350.037 +	97-951.4 EAO	
87:	64	1	S4 AUX	PB SW	WHT,NO LED	-	97-350.037 +	97-951.9 EAO	
88:	65	1	S5 RPT	PB SW	GRN	-	97-350.037 +	97-951.5 EAO	
89:	66	1	U1	CMOS IC		SOIC	CD4001BD		
90:	67	1	U2	OPAMP		SOIC	LF353M		
91:	68	2	U3,U4	CMOS IC		SOIC	CD4013BD		
92:	69	1	U5	AUD AMP			TDA2003H (Horiz. Mount)		
93:	70	1	U6	V REG		SO	MC78L05ACD		
94:	71	1	U7	I SENSE IC		SSO	MAX4172ESA		
95:	72	1	U8	BAT CHG		SOIC	BQ2000SN	UNITRODE	
96:	73	1	U9	CMOS IC		SOIC	CD4011BD		
97:	74	1	-	PC BOARD			102262		
98:	NOTES:								
99:	1) ALL CHIP PARTS WITH SIZE SHOWN AS ~ ARE 1206.								
100:	2) ELECTROLYTIC CAPACITORS ARE NIC, (GARRET) SERIES NACE OR EQUIV.								
101:	3) MOLEX MATCHING HOUSINGS ARE 51065-CXX0, X=# OF PINS								
102:	RECEPTACLES (PINS) ARE 50212-8100, LOOSE, OR 50212-8000, REEL (FOR WIRE 26-30 AWG)								
103:	CRIMP TOOL REQUIRED.								