



It's Hard To Stop A Trane.®

INSTALLER'S GUIDE

TTP-IN-1D 18-AC34D1-5

Library	Service Literature
Product Section	Unitary
Product	Split System Cooling
Model	TTP
Literature Type	Installer's Guide
Sequence	1D
Date	June 2000
File No.	SV-UN-S/S-TTP-IN-1D 6/00
Supersedes	TTP-IN-1C

Model:

TTP018-024C, TTP030-048D & TTP060E Condensing Units

IMPORTANT — This Document is **customer property** and is to remain with this unit. Please return to service information pack upon completion of work.

These instructions do not cover all variations in systems nor provide for every possible contingency to be met in connection with installation. All phases of this installation must comply with NATIONAL, STATE AND LOCAL CODES. Should further information be desired or should particular problems arise which are not covered sufficiently for the purchaser's purposes, the matter should be referred to your installing dealer or local distributor.

A. GENERAL

The following instructions cover TTP018-024C, TTP030-048D & TTP060E Condensing Units.

NOTICE: These outdoor units may be used with indoor units equipped with Capillary Tube, Thermostatic Expansion Valve or the Accutron™ Flow Control Check Valve (F.C.C.V.) assembly for refrigerant flow control.

Check for transportation damage after unit is uncrated. Report promptly, to the carrier, any damage found to the unit.

To determine the electrical power requirements of the unit, refer to the nameplate of the unit. The electrical power available must agree with that listed on the nameplate.

B. LOCATION & PREPARATION OF THE UNIT

1. The unit should be set on a level support pad at least as large as the unit base pan.
2. The support pad must NOT be in direct contact with any structure. Unit must be positioned a minimum of 12" from any wall or surrounding shrubbery to insure adequate airflow. Clearance must be provided in front of control box (access panels) & any other side requiring service access to meet National Electrical Code. Also, the unit location must be far enough away from any structure to prevent excess roof run-off water from pouring directly on the unit.
3. The top discharge area must be unrestricted for at least five (5) feet above the unit.
4. When the outdoor unit is mounted on a roof, be sure the roof will support the unit's weight. Properly selected isolation is recommended to prevent transmission to the building structure.

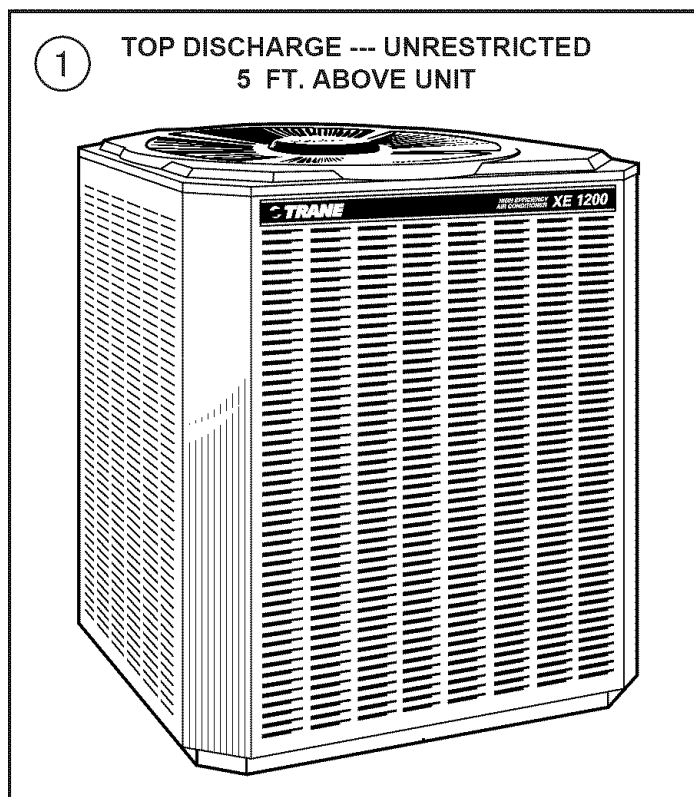

5. The maximum length of refrigerant lines from outdoor to indoor unit should NOT exceed sixty (60) feet.
6. If outdoor unit is mounted above the air handler, maximum lift should not exceed sixty (60) feet (suction line). If air handler is mounted above condensing unit, maximum lift should not exceed sixty (60) feet (liquid line).

NOTE: Refer to Refrigerant Piping Software, Pub. No. 22-3312-01.

7. Locate and install indoor coil or air handler in accordance with instruction included with that unit.

Since The Trane Company has a policy of continuous product and product data improvement, it reserves the right to change design and specifications without notice.

INSTALLER'S GUIDE

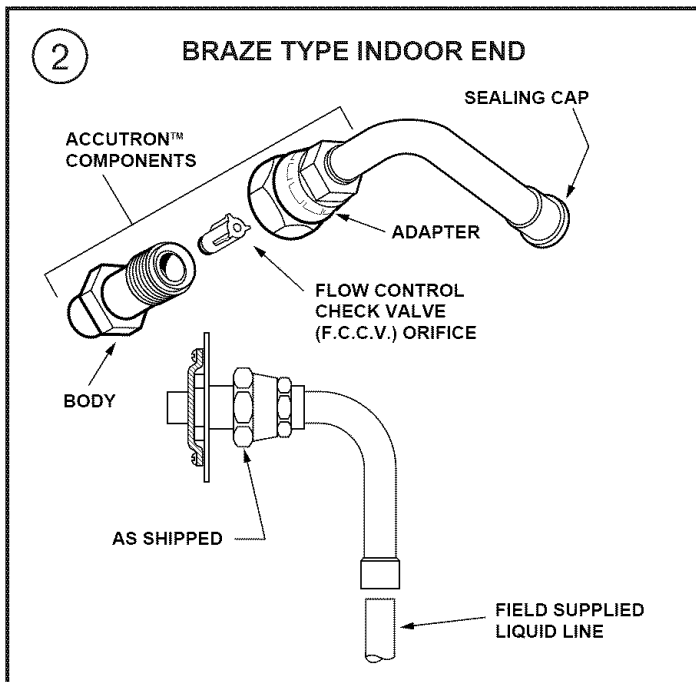

C. ACCUTRON™ FLOW CONTROL VALVE

If the indoor unit System Refrigerant Flow control is an Accutron™ orifice and check valve assembly, an orifice size change will be necessary.

The outdoor model determines the required orifice size. Check the listed orifice size on nameplate of the selected outdoor model. If the indoor unit is factory shipped with a different orifice size, the orifice must be changed to obtain system rated performance.

IMPORTANT: The outdoor unit is shipped with the proper size orifice and a stick-on orifice size label in an envelope attached to the outdoor unit. Outdoor unit nameplate will have correct orifice size specified as BAYFCCV - - - A for rated performance.

D. INSTALLING REFRIGERANT LINES

Condensing units have provisions for braze connections.

Pressure taps are provided on the service valves of outdoor unit for compressor suction and liquid pressures.

The indoor end of the recommended refrigerant line sets may be straight or with a 90 degree bend, depending upon situation requirements. This should be thoroughly checked out before ordering refrigerant line sets.

The gas line must always be insulated.

The units are factory charged with the system charge required when using fifteen (15) feet of connecting line. Unit nameplate charge is the same.

Final refrigerant charge adjustment is necessary. Use the Charging Charts in the outdoor unit Service Facts.

1. Determine the most practical way to run the lines.
2. Consider types of bends to be made and space limitations.

NOTE: Large diameter tubing will be very difficult to rebend once it has been shaped.

3. Determine the best starting point for routing the refrigerant tubing- **INSIDE OR OUTSIDE THE STRUCTURE.**

4. Provide a pull-thru hole of sufficient size to allow both liquid and gas lines. The location of this hole (if practical) should be just above the wall plate which is resting on the foundation.

5. Be sure the tubing is of sufficient length.

6. Uncoil the tubing --- do not kink or dent.

7. Route the tubing making all required bends and properly secure the tubing before making connections.

8. To prevent a noise within the building structure due to vibration transmission from the refrigerant lines, the following precautions should be taken:
 - a. When the refrigerant lines have to be fastened to floor joists or other framing in a structure, use isolation type hangers.
 - b. Isolation hangers should also be used when refrigerant lines are run in stud spaces or enclosed ceilings.
 - c. Where the refrigerant lines run through a wall or sill, they should be insulated and isolated.
 - d. Isolate the lines from all ductwork.

- a. When the refrigerant lines have to be fastened to floor joists or other framing in a structure, use isolation type hangers.

- b. Isolation hangers should also be used when refrigerant lines are run in stud spaces or enclosed ceilings.

- c. Where the refrigerant lines run through a wall or sill, they should be insulated and isolated.

- d. Isolate the lines from all ductwork.

E. SERVICE VALVE OPERATION

BRASS LIQUID LINE SERVICE VALVE

The Brass Liquid Line Service Valve is factory shipped in the seated position to hold factory charge. The pressure tap service port (when depressed) opens only to the field brazing side of the valve when the valve is in the seated position. The liquid line valve is **not** a back seating valve (see **WARNING** below).

⚠ WARNING: Extreme caution should be exercised so the internal steel stem retaining ring is not damaged by backing out the valve stem when opening the valve. If the valve stem is forced out past the retaining ring, system pressure could force the valve stem out of the valve body. If the retaining ring is missing, do not attempt to open the valve. See Figure 3.

BRASS GAS LINE SERVICE VALVE

The Brass Gas Line Service Valve is shipped in the closed position to hold the factory refrigerant charge. The pressure tap service port (when depressed) opens only to the field brazing side when the valve is in the closed position.

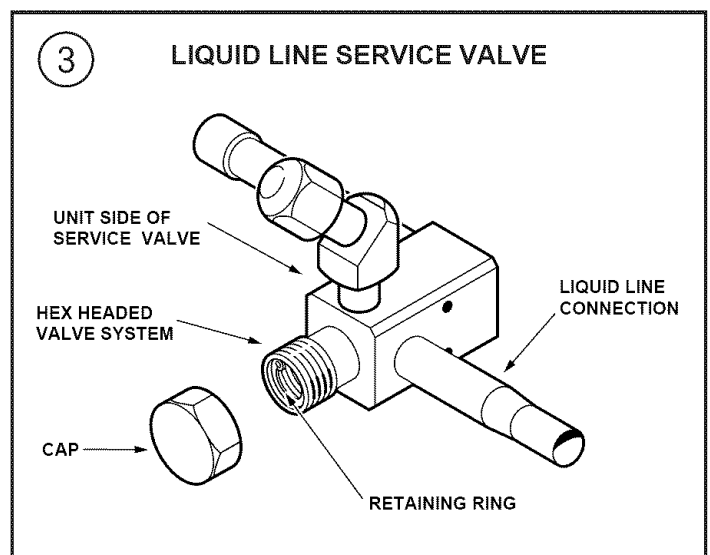

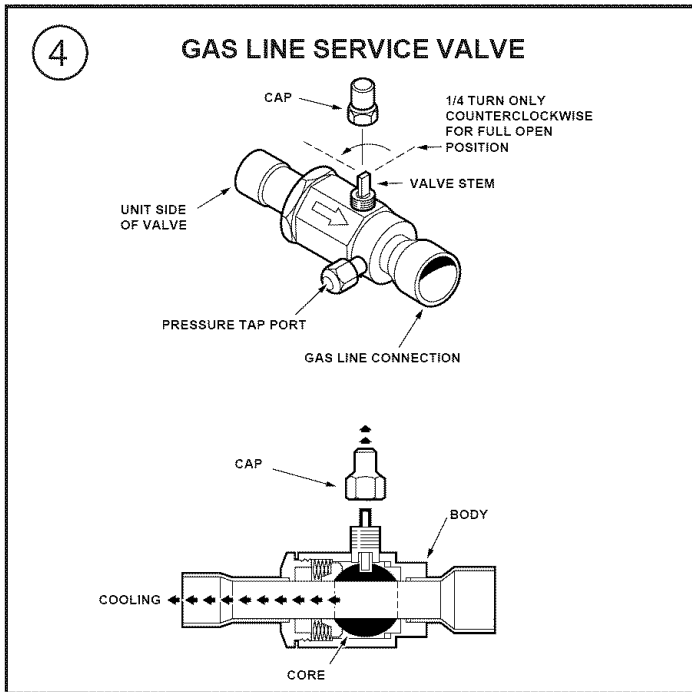

The Gas Line Service Valve is full open with a 1/4 turn. See Figure 4.

BRAZING REFRIGERANT LINES

1. Before brazing, remove plugs from external copper stub tubes. Clean internal and external surfaces of stub tubes prior to brazing.
2. Cut and fit tubing minimizing the use of sharp 90° bends.
3. Insulate the entire gas line and its fittings.
4. Do **NOT** allow uninsulated liquid line to come in direct contact with bare gas line.
5. Precautions should be taken to avoid heat damage to the pressure tap valve core during brazing. It is recommended that the pressure tap port valve core be removed and a wet rag wrapped around the valve body.

▲ CAUTION: Use care to make sure that no moisture enters pressure tap port, while wet rag is being used.

6. Remove braze shield from clear plastic bag. Soak pad in water and place over suction and liquid lines to protect unit finish. See Figure 5. Discard pad when finished with brazing.
7. Use a Dry Nitrogen Purge and Brazing Alloy without flux when brazing the field line to the copper factory connection. Flow dry nitrogen into either valve pressure tap port, thru the tubing and out the other port while brazing.
8. Braze using accepted good brazing techniques.

LEAK CHECK

▲ CAUTION: In scroll compressor applications, dome temperatures may be hot. Do not touch top of compressor, may cause minor to severe burning.

IMPORTANT: Replace pressure tap port valve core before attaching hoses for evacuation.

After the brazing operation of refrigerant lines to both the outdoor and indoor unit is completed, the field brazed connections must be checked for leaks. Pressurize through the service valve ports, the indoor unit and field refrigerant lines with dry nitrogen to 200 psi. Use soap bubbles or other leak-checking methods to see that all field joints are leak-free! If not, **release pressure**; then repair!

SYSTEM EVACUATION

NOTE: Since the outdoor unit has a refrigerant charge, the gas and liquid line valves must remain closed.

1. Upon completion of leak check, evacuate the refrigerant lines and indoor coil before opening the gas and liquid line valves.
2. Attach appropriate hoses from manifold gauge to gas and liquid line pressure taps.

NOTE: Unnecessary switching of hoses can be avoided and complete evacuation of all lines leading to sealed system can be accomplished with manifold center hose and connecting branch hose to a cylinder of HCFC-22 and vacuum pump.

3. Attach center hose of manifold gauges to vacuum pump.
4. Evacuate until the micron gauge reads no higher than 350 microns.
5. Close off valve to vacuum pump and observe the micron gauge. If gauge pressure rises above 500 microns in one (1) minute, then evacuation is incomplete or system has a leak.
6. If vacuum gauge does not rise above 500 microns in one (1) minute, the evacuation should be complete.
7. With vacuum pump and micron gauge blanked off, open valve on HCFC-22 cylinder and charge refrigerant lines and indoor coil with vapor to tank pressure of HCFC-22 supply.

NOTE: DO NOT VENT REFRIGERANT INTO THE ATMOSPHERE.

8. Close valve on HCFC-22 supply cylinder. Close valves on manifold gauge set and remove refrigerant charging hoses from liquid and gas pressure tap ports.

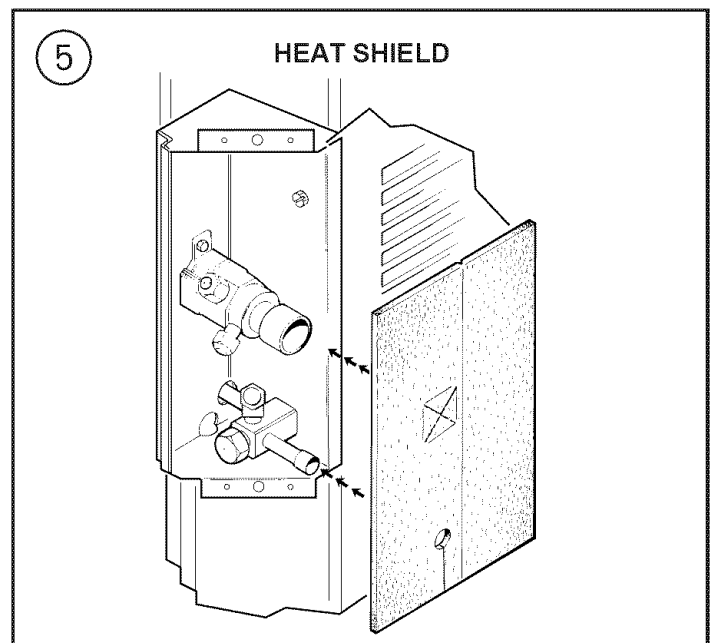

INSTALLER'S GUIDE

NOTE: A 3/16" Allen wrench is required to open liquid line service valve. A 1/4" Open End or Adjustable wrench is required to open gas line valve. A 3/4" Open End wrench is required to take off the valve stem cap.

9. The liquid line shut-off valve can now be opened. Remove shut-off valve cap. Fully insert hex wrench into the stem and backout counterclockwise until valve stem just touches retainer ring (approximately five (5) turns) observing **WARNING** statement on page 2. See Figure 3.

10. Replace liquid service pressure tap port cap and valve stem cap. These caps **MUST BE REPLACED** to prevent leaks. Replace valve stem and pressure tap cap finger tight, then tighten an additional 1/6 turn.

11. The gas valve can now be opened. Open the gas valve by removing the shut-off valve cap and turning the valve stem 1/4 turn counterclockwise, using 1/4" Open End or Adjustable wrench. See Figure 4.

12. The gas valve is now open for refrigerant flow. Replace valve stem cap to prevent leaks. See Figure 4.

If refrigerant lines are longer than 25 feet and/or a different size than recommended, it will be necessary to adjust system refrigerant charge upon completion of installation.

F. ELECTRICAL CONNECTIONS

⚠ CAUTION: Three phase scroll compressors will run in reverse if powered up with improper phasing. If the compressor is running backwards there will be little or no difference in suction and discharge pressure and it will make a distinct louder sound. Reversing any two of the field installed power leads will correct the compressor rotation. Failure to change the power leads to correct compressor rotation may result in compressor damage during operation.

⚠ WARNING: When installing or servicing this equipment, ALWAYS exercise basic safety precautions to avoid the possibility of electric shock.

⚠ CAUTION: Three phase scroll compressors will run in reverse if powered up with improper phasing.

1. Power wiring and grounding of equipment must comply with local codes.
2. Power supply must agree with equipment nameplate.
3. Install a separate disconnect switch at the outdoor unit.
4. Ground the outdoor unit per local code requirements.
5. Provide flexible electrical conduit whenever vibration transmission may create a noise problem within the structure.
6. The use of color coded low voltage wire is recommended to simplify connections between the outdoor unit, the thermostat and the indoor unit.

Table 1 --- NEC Class II Control Wiring

24 VOLTS	
WIRE SIZE	MAX. WIRE LENGTH
*22 AWG	30 FT.
20 AWG	100 FT.
18 AWG	150 FT.
16 AWG	225 FT.
14 AWG	300 FT.

*If 22 AWG is used, make sure it is **high** quality wire.

7. Table 1 defines maximum **total** length of low voltage wiring from outdoor unit, to indoor unit, and to thermostat.

8. Mount the indoor thermostat in accordance with instruction included with the thermostat. Wire per appropriate hook-up diagram (included in these instructions).

G. COMPRESSOR SUMP HEAT

All models are equipped with compressor sump heat except TTP030, 036, 042, & 048D100A.

After all electrical wiring is complete, SET THE THERMOSTAT SYSTEM SWITCH IN THE OFF POSITION SO COMPRESSOR WILL NOT RUN, and apply power by closing the system main disconnect switch. This will activate the compressor sump heat. Do not change the Thermostat System Switch until power has been applied long enough to evaporate any liquid HCFC-22 in the compressor (30 minutes for each pound of HCFC-22 in the system as shown on the nameplate). Following this procedure will prevent compressor damage at the initial start-up.

Record the "POWER APPLIED DATE" on the designated lines below:

Time _____ A.M./P.M. Date _____

By _____
(Electrician)

H. OPERATIONAL AND CHECKOUT PROCEDURES

Final phases of this installation are the unit Operational and Checkout Procedures which are found in this instruction. To obtain proper performance, all units must be operated and charge adjustments made in accordance with procedures found in the Service Facts.

I. ELECTRIC HEATERS

Electric heaters, if used, are to be installed in the air handling device according to the instructions accompanying the air handler and the heaters.

J. START CONTROL

The single phase units have quick start components which are factory installed, except for TTP030-48D100A & TTP060E100A. Provisions are made in the these units for field installed BAYKSKT252A plug-in accessory start kit, as required. The kit is installed inside the control box of the unit.

K. OUTDOOR THERMOSTAT

An outdoor thermostat TAYSTAT250A may be field installed. For data, see wiring diagram attached to unit and instruction sheet packaged with outdoor thermostat.

INSTALLER'S GUIDE

A TYPICAL FIELD WIRING DIAGRAM FOR TTP018-060 WITH AIR HANDLER

NOTES:

1. POWER WIRING AND GROUNDING OF EQUIPMENT MUST COMPLY WITH LOCAL CODES.
2. BE SURE POWER SUPPLY AGREES WITH EQUIPMENT NAMEPLATE.
3. LOW VOLTAGE WIRING TO BE NO. 18 A.W.G. MINIMUM CONDUCTOR.
4. USE COPPER CONDUCTORS ONLY.
5. POLARIZED PLUG SECTION PM-A IS ATTACHED TO HEATER CONTROL BOX. SECTION 1-PF IS FACTORY WIRED INTO AIR HANDLER.
6. IF ODT IS NOT USED, THEN CONNECT APPROPRIATE JUMPER FROM W1 TO W2 ON LVTB.

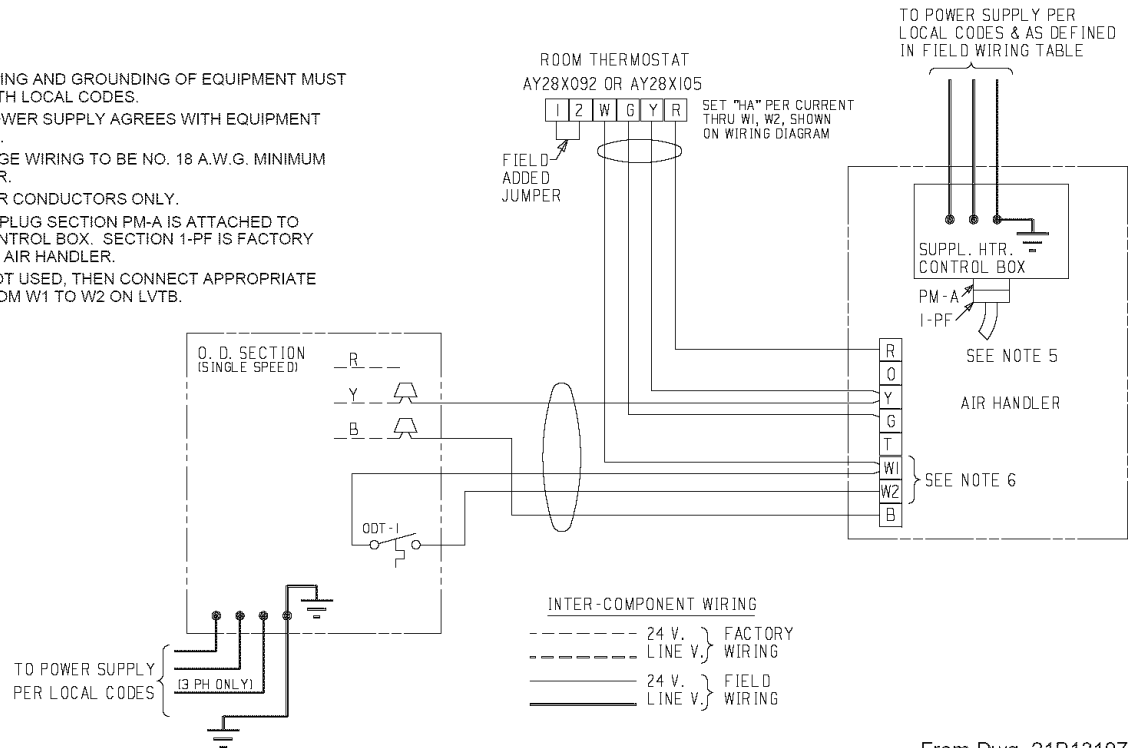

From Dwg. 21B131075 Rev. 2

A TYPICAL FIELD WIRING DIAGRAM FOR TTP018-060 WITH FURNACE FOR SINGLE STAGE HEATING, SINGLE STAGE COOLING

FIELD WIRING DIAGRAM

FOR SINGLE STAGE HEATING/COOLING
(OUTDOOR SECTION WITHOUT TRANSFORMER)

NOTES:

1. BE SURE POWER AGREES WITH EQUIPMENT NAMEPLATE(S).
2. LOW VOLTAGE (24 V. WIRING) TO BE NO. 18 A.W.G. MIN.
3. GROUNDING OF EQUIPMENT MUST COMPLY WITH LOCAL CODES.
4. SET THERMOSTAT HEAT ANTICIPATOR PER UNIT WIRING DIAGRAM.
5. THESE LEADS PROVIDE 115 V. POWER FOR CONNECTION OF ELECTRONIC AIR CLEANER AND HUMIDIFIER MAX. LOAD 1.0 AMPS EACH.
6. THE "Y" TERMINAL FROM THE THERMOSTAT MUST BE WIRED TO THE "Y" TERMINAL OF THE FURNACE CONTROL FOR PROPER BLOWER OPERATION DURING COOLING.
7. IGNITION CONTROL IS POLARITY SENSITIVE, HOT LEG OF 120 VOLT POWER SUPPLY MUST BE CONNECTED TO THE BLACK LINE POWER LEAD AS INDICATED ON THE WIRING DIAGRAM OR IGNITION LOCKOUT WILL OCCUR.

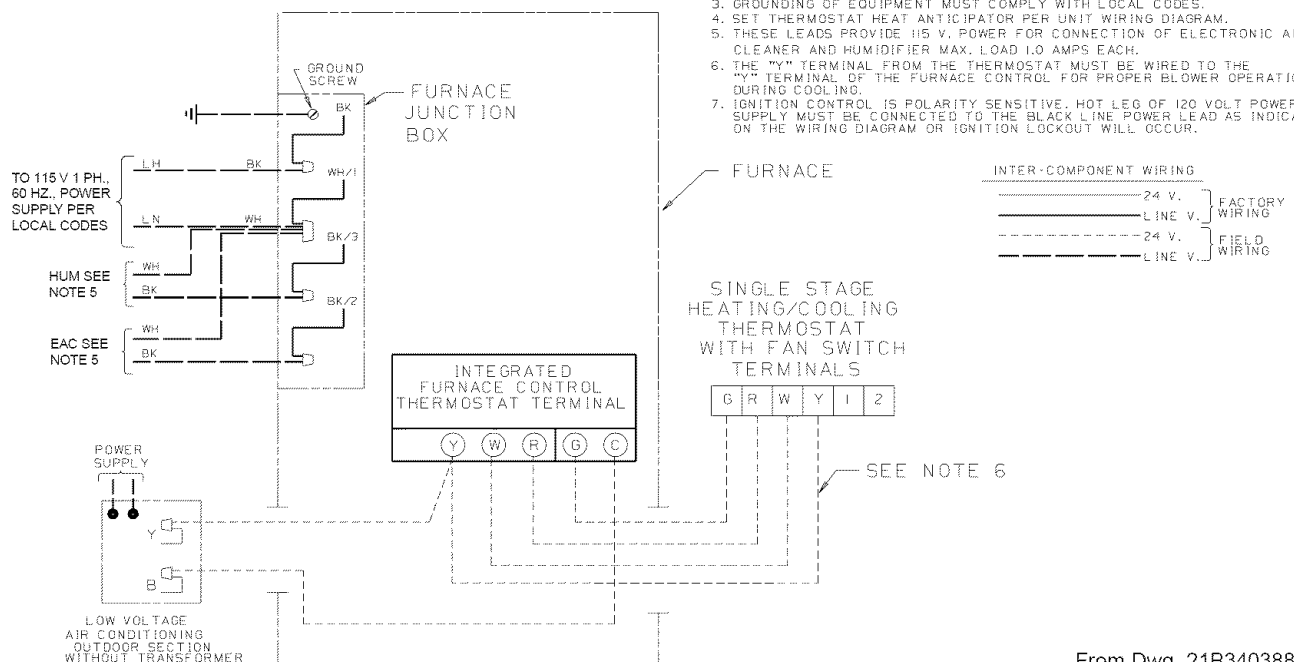

From Dwg. 21B340388 Rev. 1

INSTALLER'S GUIDE

TTP018-060 OUTLINE DRAWING

SERVICE PANEL →
ELECTRICAL AND REFRIGERANT
COMPONENTS CLEARANCES
PER PREVAILING CODES.

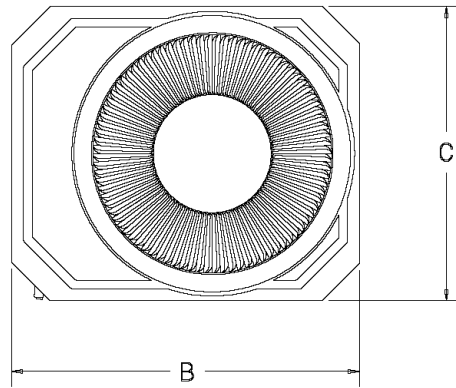

**NOTE: ALL DIMENSIONS IN
MM (INCHES).**

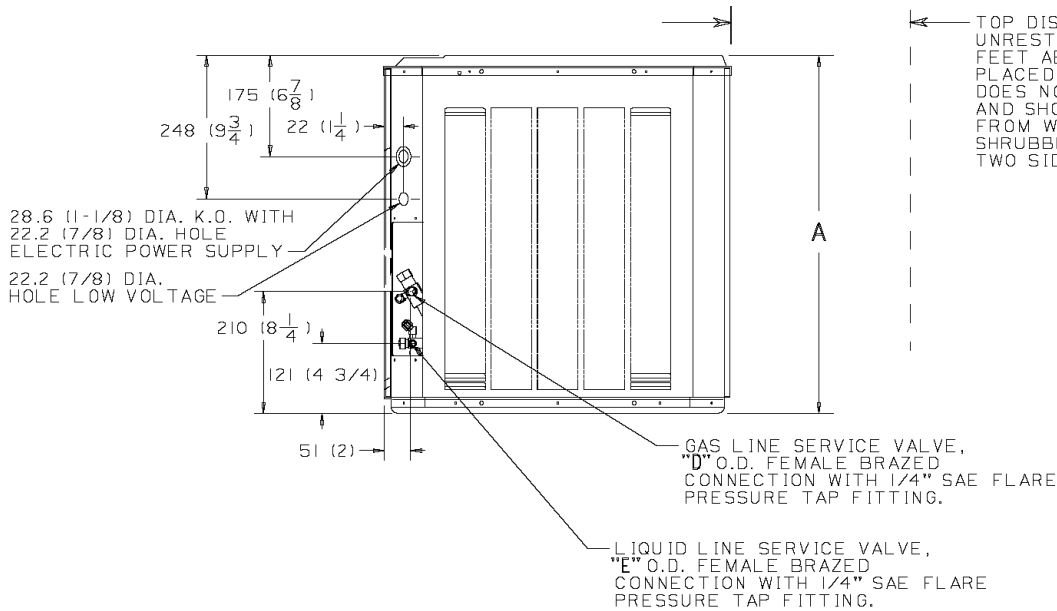

TOP DISCHARGE AREA SHOULD BE
UNRESTRICTED FOR AT LEAST FIVE (5)
FEET ABOVE UNIT. UNIT SHOULD BE
PLACED SO ROOF RUN-OFF WATER
DOES NOT POUR DIRECTLY ON UNIT,
AND SHOULD BE AT LEAST 305 (12")
FROM WALL AND ALL SURROUNDING
SHRUBBERY ON TWO SIDES. OTHER
TWO SIDES UNRESTRICTED.

FIG. 1

MODELS	FIG.	A	B	C	D	E
TTP018C	2	28-5/8	32-7/8	28-3/4	5/8	1/4
TTP024C	2	32-3/4	32-7/8	28-3/4	3/4	5/16
TTP030D	2	40-5/8	32-7/8	28-3/4	3/4	5/16
TTP036D	2	40-5/8	32-7/8	28-3/4	7/8	3/8
TTP042D	2	37	38-7/8	34-3/4	7/8	3/8
TTP048D	2	37	38-7/8	34-3/4	1-1/8	3/8
TTP060E	2	37	38-7/8	34-3/4	1-1/8	3/8

NOTE: TABLE IN INCHES ONLY.

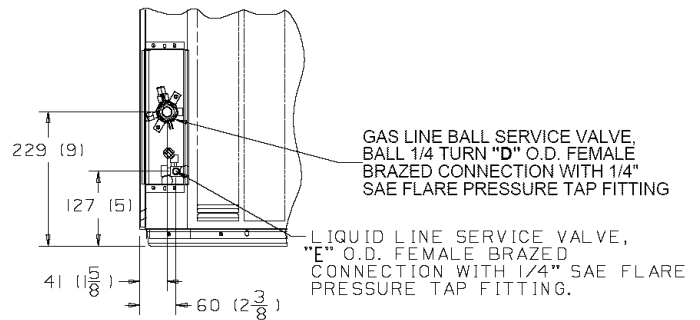

FIG. 2

From Dwg. 21D147561 Rev. 10

INSTALLER'S GUIDE

CHECKOUT PROCEDURE

After installation has been completed, it is recommended that the entire system be checked against the following list:

1. Refrigerant Line, Leak checked []
2. Suction Lines and Fittings properly insulated []
3. Have all Refrigerant Lines been secured and isolated properly? []
4. Have passages through masonry been sealed? If mortar is used, prevent mortar from coming into direct contact with copper tubing []
5. Indoor coil drain line drains freely. Pour water into drain pan []
6. Supply registers and return grilles open and unobstructed []
7. Return air filter installed []
8. Thermostat thermometer is accurate. Check against a reliable thermometer. Adjust per instructions with thermostat []
9. Is correct speed tap being used? (Indoor blower motor) []

SYSTEM OPERATIONAL CHECK

IMPORTANT: To prevent compressor damage which may result from the presence of LIQUID refrigerant in the crankcase, these procedures should be followed at initial Start-Up and at anytime the power has been off for 12 hours or more.

1. Before proceeding with this "Operational Check," go to "Compressor Sump Heat Section" of this instruction to determine the time compressor heat has been "ON," and make entry of the designated lines, in Step 2.
2. Start-Up Time _____ A.M./P.M. Power Applied Time _____ A.M./P.M.
Time Lapse _____ Hours _____ Minutes.
3. If Steps 1 and 2 cannot be used, then place thermostat's system switch in the "OFF" position and apply power by closing system disconnect switch. This energizes compressor heat and evaporates the liquid in the crankcase. **TO EVAPORATE LIQUID ALLOW AT LEAST ONE-HALF HOUR PER POUND (HCFC-22), AS SHOWN ON UNIT NAMEPLATE.**

OPERATING PRESSURES: After the unit has operated in the cooling mode for a short period of time, install pressure gauges on the gauge ports of the discharge and suction line valves. Check the suction and discharge pressures and compare them to the normal operating pressures provided in the unit's Service Facts.

NOTE: Use the pressures from Service Facts to determine the unit refrigerant charge. To charge the system accurately, use superheat charging, or pressures depending on flow control.

4. Except as required for safety while servicing: **DO NOT OPEN SYSTEM DISCONNECT SWITCH.**

SUPPLEMENTARY HEATERS CHECKOUT PROCEDURES, IF USED

DOES HEATER REQUIRE A SEPARATE CIRCUIT?

1. Be sure the fused disconnect switch is "OFF," and safety label (if any) is attached []
2. Check on field wiring for sound connections and grounding according to codes []
3. Check fuses for proper size per nameplate specifications []
4. Check control box panel — in place and secured []

NOTE: OPERATION OF HEATERS MUST BE CHECKED DURING THE OPERATION CHECK OF THE TOTAL SYSTEM.

INSTALLER'S GUIDE

CHECKOUT PROCEDURE WITH MAIN POWER DISCONNECTS CLOSED (ON)

Step No.	TO CHECK	INDOOR THERMOSTAT SWITCH SETTING				COMPONENT OPERATION					
		Off	① Cool	① Heat	Fan Switch		Indoor Blower Runs	Outdoor Fan Runs	Compressor Runs	Comp. Sump Heater	Furnace Heat Comes On
					Auto	On					
1	Sump Heat	X			X					X	
2	Indoor Fan Operation	X				X	X			X	
3	Cooling Operation		X		X		X	X	X	X	
4	Checking Performance & Charge		X		X		X	X	X	X	
← USE CHARTS ATTACHED TO O.D. UNIT →											
5	Heating ②			X	X		X			X	X
6	Inform owner on how to operate system and what to expect of it. At the same time deliver Owner's Use and Care Booklet.										

① Also set thermostat dial to call for cooling or heating as necessary.

② Check only necessary if heating unit is used for indoor section and wiring has been disturbed during installation of cooling equipment.

Since American-Standard has a policy of continuous product and product data improvement, it reserves the right to change design and specifications without notice.

Technical Literature - Printed in U.S.A.

The Trane Company
 Unitary Products Group
 6200 Troup Highway
 Tyler, TX 75707