



18 - CD19D6 - 31

Available in French Canadian (FC)

Installer's Guide

Upflow/ Horizontal and Downflow/ Horizontal Gas-Fired, Direct Vent Condensing Furnaces

- | | | |
|----------------|----------------|----------------|
| *UX1B040A9241A | *UX1C080A9601A | *DX1B040A9241A |
| *UX1B060A9241A | *UX1C100A9361A | *DX1B060A9361A |
| *UX1B060A9361A | *UX1C100A9481A | *DX1B080A9421A |
| *UX1B080A9241A | *UX1D100A9601A | *DX1C100A9481A |
| *UX1B080A9421A | *UX1D120A9601A | *DX1D120A9601A |

*__First letter may be "A" or "T"

ALL phases of this installation must comply with NATIONAL, STATE AND LOCAL CODES

IMPORTANT — This Document is **customer property** and is to remain with this unit. Please return to service information pack upon completion of work.



*UX-1

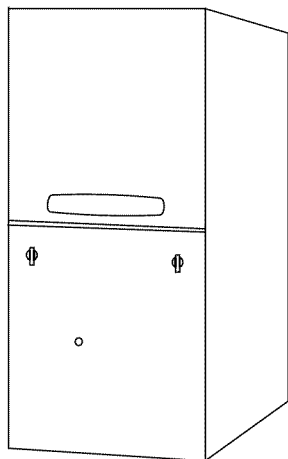

AIR FLOW

UPFLOW

*DX-1

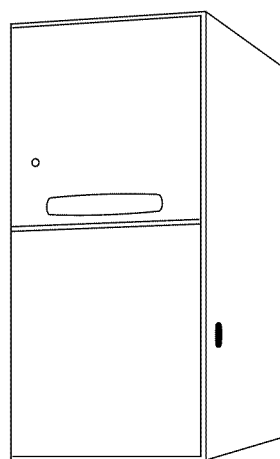

DOWNFLOW

AIR FLOW

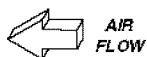

AIR FLOW

UPFLOW/HORIZONTAL

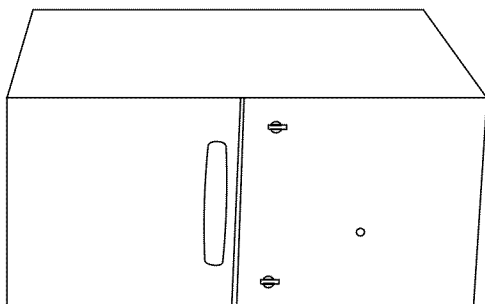

DOWNFLOW/HORIZONTAL

AIR FLOW

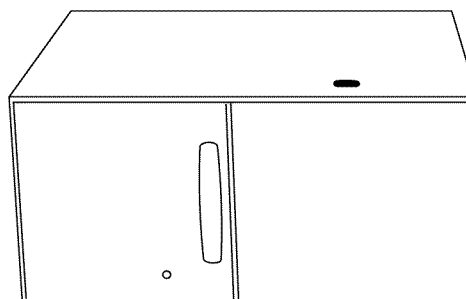

Installer's Guide

SAFETY SECTION

The following safety practices and precautions must be followed during the installation, servicing, and operation of this furnace.

1. Use only with the type of gas approved for this furnace. Refer to the furnace rating plate.
2. Install this furnace only in a location and position as specified in "Location and Clearances" (page 4), of these instructions.
3. Provide adequate combustion and ventilation air to the furnace space as specified in "Air for Combustion and Ventilation" (pages 8-9), of these instructions.
4. Combustion products must be discharged outdoors. Connect this furnace to an approved vent system only, as specified in the "Venting" section (starting on page 15), of these instructions.
5. Never test for gas leaks with an open flame. Use a commercially available soap solution made specifically for the detection of leaks to check all connections, as specified in "Gas Piping" (pages 31-33), of these instructions.
6. Always install the furnace to operate within the furnace's intended temperature-rise range with a duct system which has an external static pressure within the allowable range, as specified on the unit rating plate. Airflow with temperature rise for cfm versus static is shown in the Service Facts accompanying this furnace.
7. When a furnace is installed so that supply ducts carry air circulated by the furnace to areas outside the space containing the furnace, the return air shall also be handled by a duct(s) sealed to the furnace casing and terminating outside the space containing the furnace.
8. A gas-fired furnace for installation in a residential garage must be installed as specified in "Location and Clearances" section (page 4), of these instructions.
9. The furnace may be used for temporary heating of buildings or structures under construction only when the following conditions have been met:
 - a. The furnace venting system must be complete and installed per manufacturer's instructions.
 - b. The furnace is controlled only by a room thermostat (no field jumpers).
 - c. The furnace return air duct must be complete and sealed to the furnace and clean air filters are in place.
 - d. The furnace input rate and temperature rise must be verified to be within nameplate marking.
 - e. 100% of the furnace combustion air requirement must come from outside the structure.

- f. The furnace return air temperature range is between 55 and 80 degrees Fahrenheit.
- g. Clean the furnace, duct work, and components upon substantial completion of the construction process, and verify furnace operating conditions including ignition, input rate, temperature rise and venting, according to the manufacturer's instructions.

10. This product must be gas piped by a Licensed Plumber or Gas Fitter in the Commonwealth of Massachusetts.

WARNING

CARBON MONOXIDE POISONING HAZARD

Failure to follow the steps outlined below for each appliance connected to the venting system being placed into operation could result in carbon monoxide poisoning or death.

The following steps shall be followed for each appliance connected to the venting system being placed into operation, while all other appliances connected to the venting system are not in operation:

1. Seal any unused openings in the venting system.
2. Inspect the venting system for proper size and horizontal pitch, as required in the National Fuel Gas Code, ANSI Z223.1/NFPA 54 or the CAN/CGA B149 Installation Codes and these instructions. Determine that there is no blockage or restriction, leakage, corrosion and other deficiencies which could cause an unsafe condition.
3. As far as practical, close all building doors and windows and all doors between the space in which the appliance(s) connected to the venting system are located and other deficiencies which could cause an unsafe condition.
4. Close fireplace dampers.
5. Turn on clothes dryers and any appliance not connected to the venting system. Turn on any exhaust fans, such as range hoods and bathroom exhausts, so they are operating at maximum speed. Do not operate a summer exhaust fan.
6. Follow the lighting instructions. Place the appliance being inspected into operation. Adjust the thermostat so appliance is operating continuously.
7. If improper venting is observed during any of the above tests, the venting system must be corrected in accordance with the National Fuel Gas Code, ANSI Z221.1/NFPA 54 and/or CAN/CGA B149.1 Installation Codes.
8. After it has been determined that each appliance connected to the venting system properly vents where tested as outlined above, return doors, windows, exhaust fans, fireplace dampers and any other gas-fired burning appliance to their previous conditions of use.

Safety signal words are used to designate a degree or level of seriousness associated with a particular hazard. The signal words for safety markings are **WARNING** and **CAUTION**.

- a. **WARNING** indicates a potentially hazardous situation which, if not avoided, could result in death or serious injury.
- b. **CAUTION** indicates a potentially hazardous situation which, if not avoided, may result in minor or moderate injury. It is also used to alert against unsafe practices and hazards involving only property damage.

WARNING

FIRE OR EXPLOSION HAZARD

Failure to follow the safety warnings exactly could result in serious injury, death or property damage. Improper servicing could result in dangerous operation, serious injury, death, or property damage.

GENERAL INSTALLATION INSTRUCTIONS

The manufacturer assumes no responsibility for equipment installed in violation of any code or regulation. It is recommended that Manual J of the Air Conditioning Contractors Association (ACCA) or A.R.I. 230 be followed in estimating heating requirements. When estimating heating requirements for installation at altitudes above 2000 ft., remember the gas input may need to be reduced (See High Altitude Installation).

Material in this shipment has been inspected at the factory and released to the transportation agency without known damage. Inspect exterior of carton for evidence of rough handling in shipment. Unpack carefully after moving equipment to approximate location. If damage to contents is found, report the damage immediately to the delivering agency.

Codes and local utility requirements governing the installation of gas fired equipment, wiring, plumbing, and flue connections must be adhered to. In the absence of local codes, the installation must conform with latest edition of the National Fuel Gas Code ANSI Z223.1 • National Installation Code, CAN/CGA B149.1. The latest code may be obtained from the American Gas Association Laboratories, 400 N. Capitol St. NW, Washington D.C. 20001.

1-800-699-9277 or www.aga.org

These furnaces have been classified as CATEGORY IV furnaces in accordance with latest edition of ANSI Z21.47 • CAN/ CGA 2.3 standards.

Contents

INSTALLATION INSTRUCTIONS

General Installation Instructions	3
Location and Clearances	4
Outline Drawings	5
Upflow Installation	7
Downflow Installation	7
Horizontal Installation	7
Air For Combustion and Ventilation	8
Duct Connections	10
Return Air Filters	11
General Venting Instructions	15
Venting Material	16
Venting Tables	17-19
Horizontal Venting	20
Venting Through The Wall	20
Venting Through The Roof	23
Downward Venting	23
Venting Through a Masonry Chimney	23
Condensate Drain Instructions	26
Electrical Connections	29
Field Wiring Diagrams	28-30
Gas Piping	31
Combustion Input Checks	32

Start Up and Adjustment

Preliminary Inspections	35
Lighting Instructions	35
Sequence Of Operation	36
Control And Safety Switch Adjustments	36
Airflow Adjustment	36

Abnormal Conditions

IFC Error Flash Code	39
----------------------	----

Category IV furnaces operate with positive vent static pressure and with a flue loss less than 17 percent. These conditions require special venting systems, which must be gas tight and water tight. These Category IV Direct Vent furnaces are approved for installation in Manufactured/ Mobile housing when used with BAYMFGH100A.

Installer's Guide

⚠ CAUTION

To prevent shortening its service life, the furnace should not be used as a "Construction Heater" during the finishing phases of construction until the requirements listed in item 9, a-g of the safety section of this publication have been met. Condensate in the presence of chlorides and fluorides from paint, varnish, stains, adhesives, cleaning compounds, and cement create a corrosive condition which may cause rapid deterioration of the heat exchanger.

⚠ CAUTION

Do NOT install the furnace in a corrosive or contaminated atmosphere.

⚠ WARNING

EXPLOSION HAZARD!
PROPANE GAS IS HEAVIER THAN AIR AND MAY COLLECT IN ANY LOW AREAS OR CONFINED SPACES. IN ADDITION, ODORANT FADE MAY MAKE THE GAS UNDETECTABLE EXCEPT WITH A WARNING DEVICE. IF THE GAS FURNACE IS INSTALLED IN A BASEMENT, AN EXCAVATED AREA OR A CONFINED SPACE, IT IS STRONGLY RECOMMENDED TO CONTACT A GAS SUPPLIER TO INSTALL A GAS DETECTING WARNING DEVICE IN CASE OF A GAS LEAK.

NOTE: The manufacturer of your furnace does NOT test any detectors and makes no representations regarding any brand or type of detector.

LOCATION AND CLEARANCES

The location of the furnace is normally selected by the architect, the builder, or the installer. However, before the furnace is moved into place, be sure to consider the following requirements:

1. Is the location selected as near the vent and as centralized for heat distribution as practical?
2. Do all clearances between the furnace and enclosure equal or exceed the minimums shown in the Table 1.
3. Is there sufficient space for servicing the furnace and other equipment? A minimum of 24 inches front accessibility to the furnace must be provided. Any access door or panel must permit removal of the largest component.
4. Are there at least 3 inches of clearance between the furnace front panel and any closed panel or door provided?
5. Are the vent pipe and combustion air inlet pipe within vent table lengths? Will the pipes remain unobstructed?
6. Allow sufficient height in supply plenum above or below the furnace to provide for cooling coil installation if the cooling coil is not installed at the time of this furnace installation.
7. A furnace shall be installed so electrical components are protected from water.
8. If the furnace is installed in a **residential garage**, it must be installed so that the burners and the ignition source are located not less than 18 inches (46 cm) above the floor and the furnace must be located or protected to avoid physical damage from vehicles.

IMPORTANT:

The furnace must be installed level. The only allowable variation would be slightly to the left and/or forward in upflow installations or slightly toward the front in horizontal installations. This is necessary for proper condensate drainage.

*DX-C DOWNFLOW / HORIZONTAL OUTLINE DRAWING (ALL DIMENSIONS ARE IN INCHES)

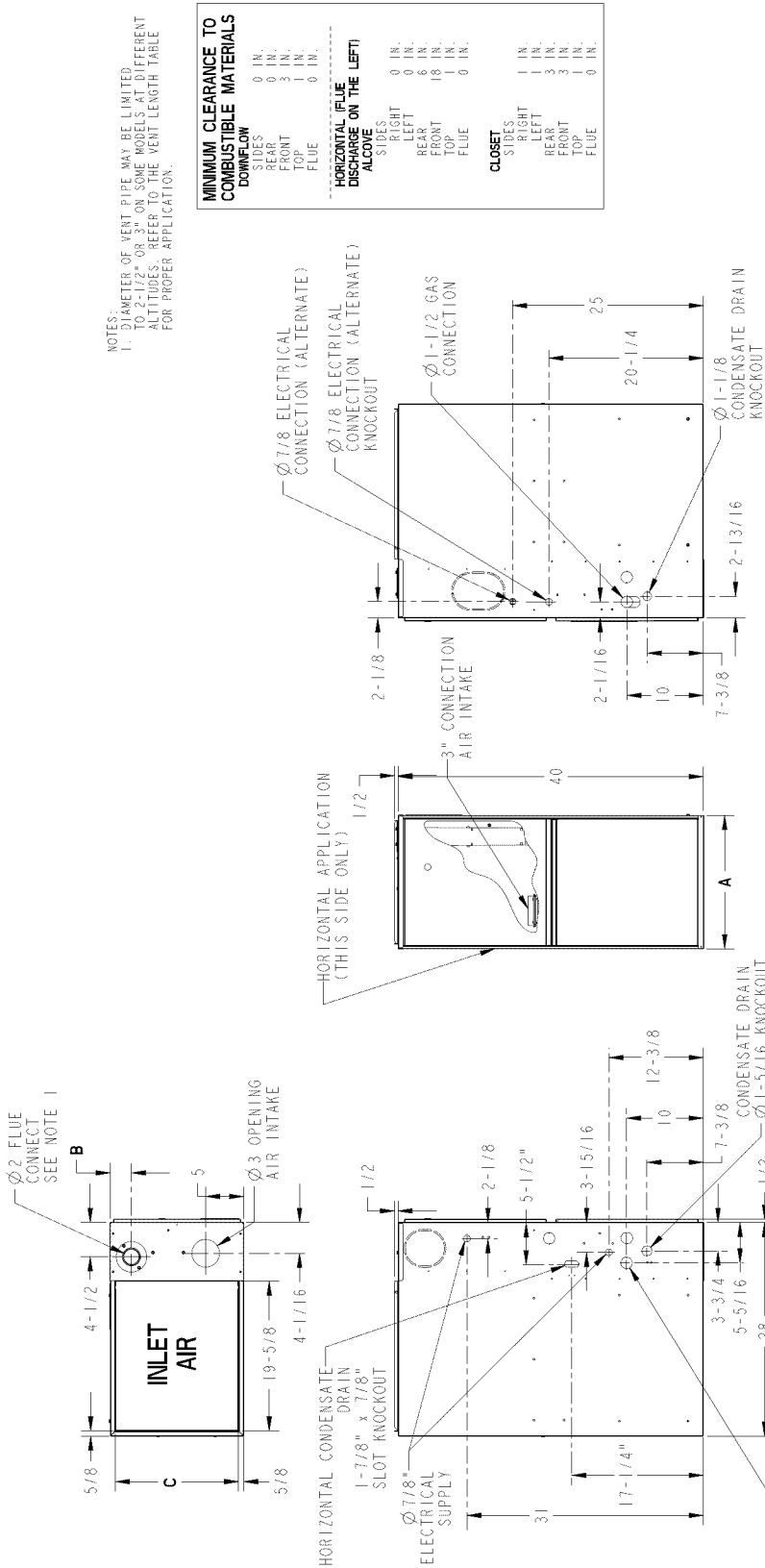

* PREFIX MAY BE "A" OR "T"
 ** SUFFIX LETTER MAY BE "D" - 0 THRU 9
 *** SUFFIX LETTER MAY BE "W" - 0 THRU 9
 ^^ SUFFIX LETTER MAY BE A - Z

MODEL (SEE NOTE 1)	DIM "A"	DIM "B"	DIM "C"	DIM "D"
*DX1B040A9241^^	17-1/2"	2-1/4"	16-1/4"	16"
*DX1B060A9361^^				
*DX1B080A9421^^				
*DX2B060A9362^^				
*DX2B080A9422^^				
*DY060R9V3***				
*DY080R9V3***				
*DX1B040A9H21^^				
*DX1B060A9H31^^				
*DX1B080A9H31^^				
*DX1C100A9481^^	21"	2-1/2"	19-3/4"	19-1/2"
*DX2C100A9482^^				
*DY100R9V4***				
*DX1D120A9H51^^	24-1/2"	2-15/16"	23-1/4"	23"
*DX1D120A9601^^				
*DX2D120A9602^^				
*DY120R9V5***				
*DX1D120A9H51^^				

UPFLOW INSTALLATION

Standoffs and screws (See Figure 1) are included with the cased coils for attachment to the furnace. There are clearance alignment holes near the bottom of the coil wrapper. Drill screws are used to engage the furnace top flanges. The standoff is inserted into the cabinet alignment hole. The drill screws are inserted through the standoffs then screwed into the furnace flange.

The coil is always placed downstream of the furnace airflow.

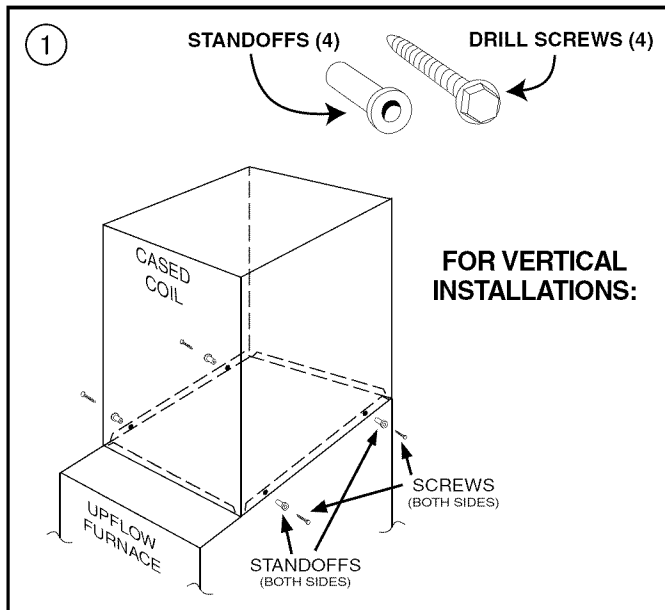

DOWNFLOW INSTALLATIONS

⚠ WARNING

Do NOT install the furnace directly on carpeting, tile or other combustible material other than wood flooring. For vertical downflow application, subbase (BAYBASE-205) must be used between the furnace and combustible flooring. When the downflow furnace is installed vertically with a cased coil, a subbase is not required.

Required floor opening:

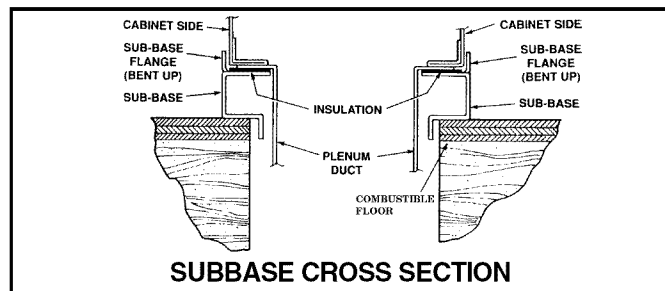
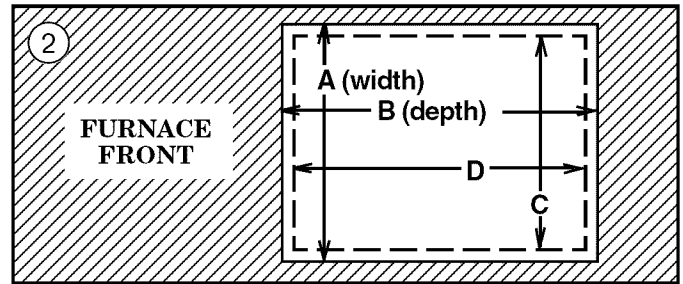

TABLE 1

CABINET WIDTH	RETURN DUCT WIDTH	FLOOR OPENING		PLENUM OPENING	
		"A"	"B"	"C"	"D"
17-1/2"	16-1/4"	16-5/8"	20-1/8"	15-5/8"	19-3/8"
21"	19-3/4"	20-1/8"	20-1/8"	19-1/8"	19-3/8"
24-1/2"	23-1/4"	23-5/8"	20-1/8"	22-5/8"	19-3/8"



HORIZONTAL INSTALLATION

The coil and furnace must be fully supported when used in the horizontal position. It is always recommended that an auxiliary drain pan be installed under a horizontally installed evaporator coil or 90% gas furnace. Connect the auxiliary drain line to a separate drain line (no trap is needed in this line).

Three brackets (with screws) are included with downflow furnaces for installation to stabilize and secure the furnace and TXC cased coil in the **horizontal position**. See Figure 4.

IMPORTANT:

The 2/4TXC cased coil must be placed downstream of the furnace. In horizontal installations, the apex of the coil may point either toward or away from the furnace. See the 2/4TXC coil Installer's Guide for more details.

The cased coil is secured to the furnace and both the furnace **and** the cased coil must be properly supported. The brackets mount using the rear screws on the coil case and use the screws provided to secure the bracket to the furnace. The remaining bracket is placed as close to center as possible (horizontally) between the coil case front and the furnace bottom channel (for downflow/horizontal furnace). Use four of the screws provided to secure the bracket. The upflow furnace, converted to horizontal, aligns and attaches the TXC coil as in Figure 1. However, the coil requires additional support.

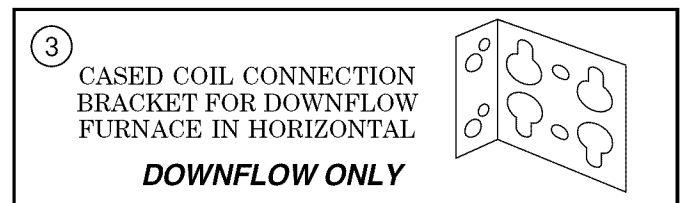

The furnace may be installed in an attic or crawl space in the horizontal position by placing the furnace *on the left side* (as viewed from the front in the vertical position). The horizontal furnace installation in an attic should be on a service platform large enough to allow for proper clearances on all sides and service access to the front of the furnace (See Figure 4 & Clearance Table). Line contact is only permissible between lines formed by intersections of the top and two sides of the furnace casing and building joists, studs, or framing.

Installer's Guide

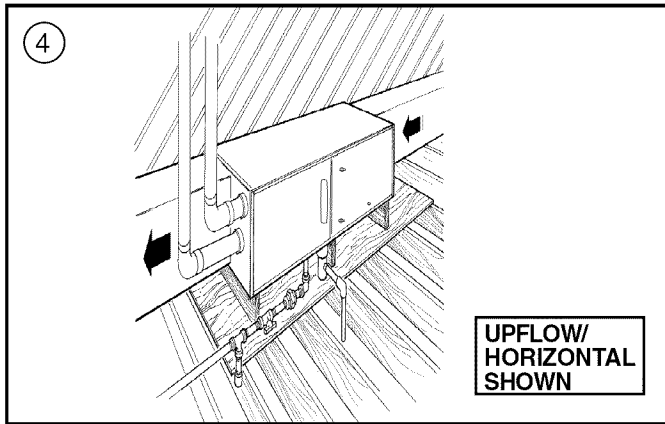

The furnace may be placed horizontally in a crawl space on a pad or other noncombustible material which will raise the unit for sufficient protection from moisture. **The furnace must be supported at both ends and the middle when installed horizontally.**

The furnace must also be elevated a minimum of 6 inches to allow clearance for the condensate drain to exit the cabinet in the horizontal position.

The horizontal furnace may also be suspended from the joists using 3/8" all-thread rods with pieces of angle iron underneath the furnace to form a hanging rack at both ends and the midpoint. The rods need to be of sufficient length to allow for proper clearances from combustible materials. The angle iron needs to be at least 32" in length to allow for access to service panels.

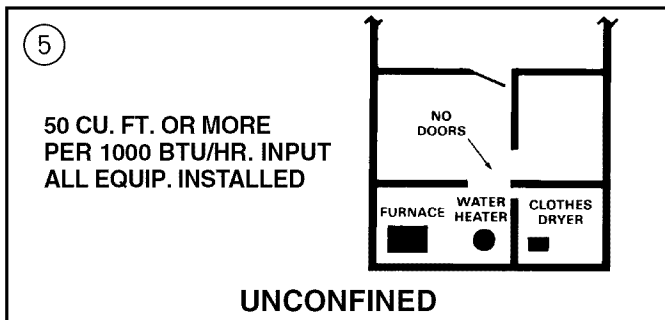

AIR FOR COMBUSTION AND VENTILATION

If these furnaces are installed in a nondirect vent capacity then the adequate flow of combustion and ventilating air must not be obstructed from reaching the furnace. Air openings provided for combustion air must be kept free of obstructions which restrict the flow of air. Airflow restrictions affect the efficiency and safe operation of the furnace. Keep this in mind should you choose to remodel or change the area which contains your furnace. Furnaces must have a free flow of air for proper performance.

Provisions for combustion and ventilation air shall be made in accordance with latest edition of Section 5.3, Air for Combustion and Ventilation, of the National Fuel Gas Code, ANSI Z223.1 — CAN/CGA B149.1 or applicable provisions of the local building codes. Special conditions created by mechanical exhausting of air and fireplaces must be considered to avoid unsatisfactory furnace operation.

OUTSIDE AIR IS RECOMMENDED

The use of indoor air for most applications is acceptable, unless **there is the presence of corrosive chemicals or contamination.** Certain types of installation will **require** the use of outside air for combustion.

The following types of installations will **require** use of OUTDOOR AIR for combustion, due to chemical exposures:

- * Commercial buildings
- * Buildings with indoor pools
- * Furnaces installed in "confined" laundry rooms
- * Furnaces installed in "confined" hobby or craft rooms
- * Furnaces installed near chemical storage areas.

Exposure to the following substances in the combustion air supply will also require OUTDOOR AIR for combustion:

- * Permanent wave solutions
- * Chlorinated waxes and cleaners
- * Chlorine based swimming pool chemicals
- * Water softening chemicals
- * Deicing salts or chemicals
- * Carbon Tetrachloride
- * Halogen type refrigerants
- * Cleaning solvents (such as perchloroethylene)
- * Printing inks, paint removers, varnish, etc.
- * Hydrochloric acid
- * Cements and glues
- * Antistatic fabric softeners for clothes dryers
- * Masonry acid washing materials

Furnace locations may be in a "confined space" or an "unconfined space".

Unconfined space is defined in Figure 5. These spaces may have adequate air by infiltration to provide air for combustion and ventilation. Buildings with tight construction (for example, weather stripping, heavily insulated, caulked, vapor barrier, etc.), may need additional air to be provided as described for *confined space*. *Confined spaces* are installations with less than 50 cu. ft. of space per 1000 BTU/hr input from all equipment installed. Air for combustion and ventilation requirements can be supplied from inside the building as in Figure 8 or from the outdoors, as in Figure 9.

6 MINIMUM AREA IN SQUARE FEET FOR UNCONFINED SPACE INSTALLATIONS	
FURNACE MAXIMUM BTUH INPUT RATING	WITH 8 FT. CEILING MINIMUM AREA IN SQUARE FEET OF UNCONFINED SPACE
60,000	375
80,000	500
100,000	625
120,000	875

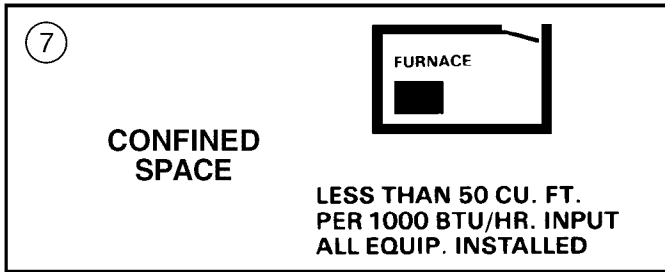

1. All air from inside the building as in Figure 8: The confined space shall be provided with two permanent openings communicating directly with an additional room(s) of sufficient volume so that the combined volume of all spaces meets the criteria for an unconfined space. The total input of all gas utilization equipment installed in the combined space shall be considered in making this determination. Refer to Table 2 for minimum open areas requirements.
2. All air from outdoors as in Figure 9: The confined space shall be provided with two permanent openings, one commencing within 12 inches of the top and one commencing within 12 inches of the bottom of the enclosure. The openings shall communicate directly, or by ducts, with the outdoors or spaces (crawl or attic) that freely communicate with the outdoors. Refer to Table 2, for minimum open areas requirements.

TABLE 2
MINIMUM FREE AREA IN SQUARE INCHES EACH OPENING (FURNACE ONLY)

Furnace Maximum BTUH/INPUT Rating	Air From Inside	Air From Outside	
		Vertical Duct	Horizontal Duct
60,000	100	15	30
80,000	100	20	40
100,000	100	25	50
120,000	120	30	60

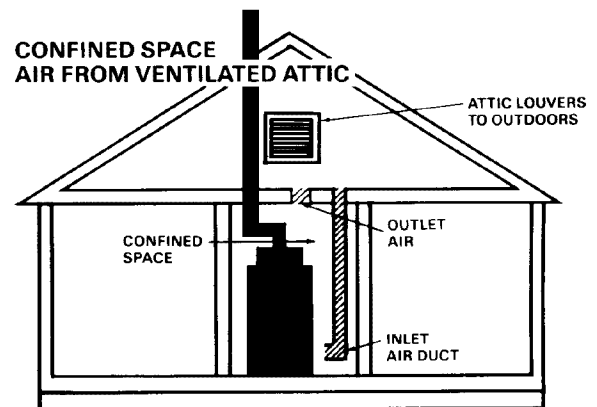
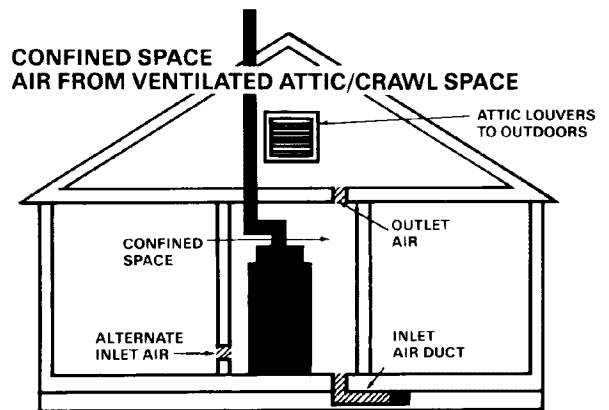
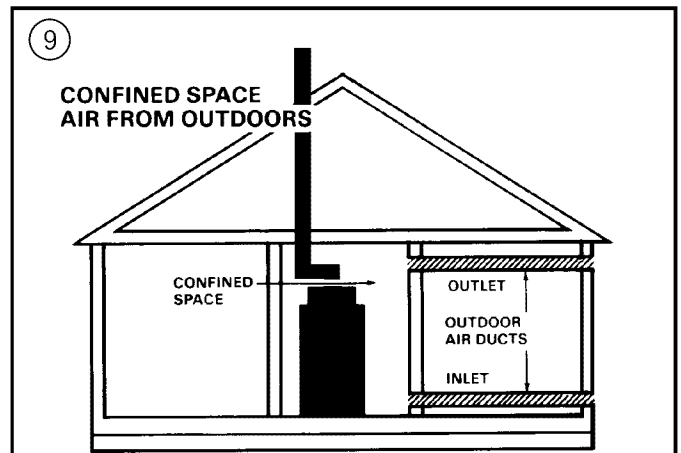
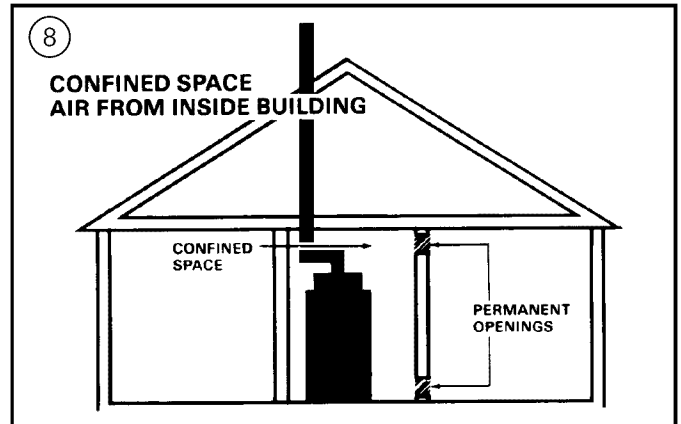

Installer's Guide

DUCT CONNECTIONS

Air duct systems should be installed in accordance with standards for air conditioning systems, National Fire Protection Association Pamphlet No. 90. They should be sized in accordance with ACCA Manual D or whichever is applicable.

Central furnaces, when used in connection with cooling units, shall be installed in parallel or on the upstream side of the cooling coil to avoid condensation in the heat exchanger. With a parallel flow arrangement, the dampers or other means used to control flow of air shall be adequate to prevent chilled air from entering the furnace, and if manually operated, must be equipped with means to prevent operation of either unit unless the damper is in full heat or cool position.

On any job, flexible connections of nonflammable material may be used for return air and discharge connections to prevent transmission of vibration. Though these units have been specifically designed for quiet, vibration free operation, air ducts can act as sounding boards and could, if poorly installed, amplify the slightest vibration to the annoyance level.

When the furnace is located in a utility room adjacent to the living area, the system should be carefully designed with returns to minimize noise transmission through the return air grille. Although these furnaces are designed with large blowers operating at moderate speeds, any blower moving a high volume of air will produce audible noise which could be objectionable when the unit is located very close to a living area. It is often advisable to route the return air ducts under the floor or through the attic. Such design permits the installation of air return remote from the living area (i.e. central hall).

When the furnace is installed so that the supply ducts carry air circulated by the furnace to areas outside the space containing the furnace, the return air shall also be handled by a duct(s) sealed to the furnace and terminating outside the space containing the furnace.

RETURN AIR DUCT SYSTEMS

Where there is no complete return duct system, the return connection must be run full size from the furnace to a location outside the utility room, basement, attic, or crawl space.

Do Not install return air through the back of the furnace cabinet

Do Not install return air through the side of the furnace cabinet on horizontal applications.

NOTE:

Minimum return air temperature is 55° F.

All return air duct systems should provide for installation of return air filters.

1. Set the furnace in place.
2. For upflow side return installations, remove the insulation around the opening in the blower compartment.
3. The side panels of the upflow furnace include locating notches that are used as guides for cutting an opening for return air, refer to Figure 10 and the outline drawing on page 4 for duct connection dimensions for various furnaces.

NOTE:

On upflow 5 ton airflow models, if the airflow requirement exceeds 1800 CFM, these models will require return air openings and filters on both sides; OR 1 side and the bottom; OR just the bottom.

4. If a 3/4" flange is to be used for attaching the air inlet duct, add to cut where indicated by dotted lines in Figure 10. Cut corners diagonally and bend outward to form flange.
5. If flanges are not required, and a filter frame is installed, cut between locating notches (See Figure 10).
6. The bottom panel of the upflow furnace must be removed for bottom return air. Lay the furnace on its back. Remove the two 1/4" hex screws securing the bottom front channel to the cabinet. Lower the front edge of the bottom front channel and pull forward to remove the channel. The bottom return air panel will now easily slide out of the cabinet. Reinstall the bottom front channel for upflow bottom return installations.
7. Use the filter retainer on side or bottom if filter is to be used within the furnace cabinet on upflow only installations.
8. ***The horizontal installation of the upflow furnace requires an external filter section. Filter kits are available for horizontal applications.***
9. Connect duct work to furnace. See Outline Drawing for supply and return duct size and location. Flexible duct connectors are recommended to connect both supply and return air ducts to the furnace. If only the front of the furnace is accessible, it is recommended that both supply and return air plenums are removable.

RETURN AIR FILTERS (Filters not supplied with unit) TYPICAL UPFLOW RETURN AIR FILTER INSTALLATIONS

These furnaces require high velocity type air filters. The filters may be located within the furnace blower compartment for UPFLOW furnaces in either a BOTTOM or SIDE (left side or right side) return air inlet.

TABLE 3

MODELS NUMBERS	CABINET WIDTH	FILTER QTY & SIZE
*UX1B040A9241A *UX1B060A9241A *UX1B060A9361A *UX1B080A9241A *UX1B080A9421A	17-1/2"	1 - 17" X 25" X 1"
*UX1C080A9601A *UX1C100A9361A *UX1C100A9481A	21"	1 - 20" X 25" X 1"
*UX1D100A9601A *UX1D120A9601A	24-1/2"	1 - 24" X 25" X 1"

*First letter may be "A" or "T"

*** NOTE - On 5 ton airflow models, if the airflow requirement exceeds 1800 CFM, these models will require filters on both sides; OR 1 side and the bottom; OR just the bottom.

NOTE:

On upflow 5 ton airflow models, if the airflow requirement exceeds 1800 CFM, these models will require return air openings and filters on both sides; OR 1 side and the bottom; OR just the bottom.

The upflow furnace blower door has a hinge at the bottom which allows the door to tilt forward for filter replacement without the door being removed (See Figure

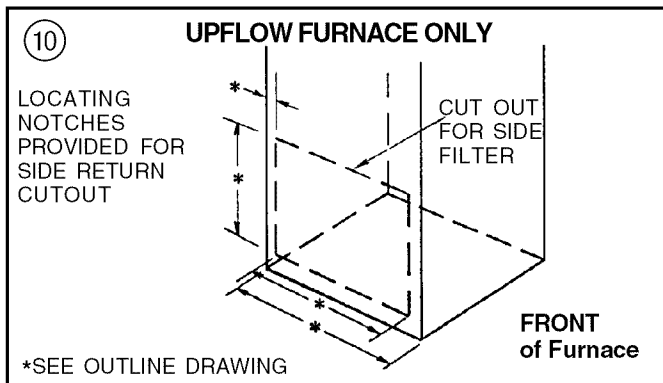

11). The optional furnace filter in the bottom or side configuration can be removed by simply turning the two latches on the blower door and tilting the door forward. The filter rails are spring loaded for automatic adjustment to allow standard size, locally obtainable replacement filters. The filter rack itself slides to adjust to the required width needed for bottom or side return (See Figure 12).

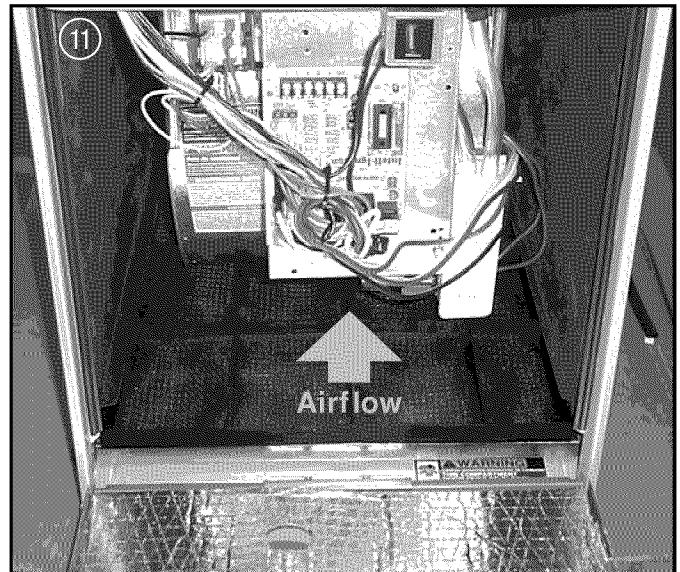

Blower Door Hinge and Bottom Filter Rack Installation

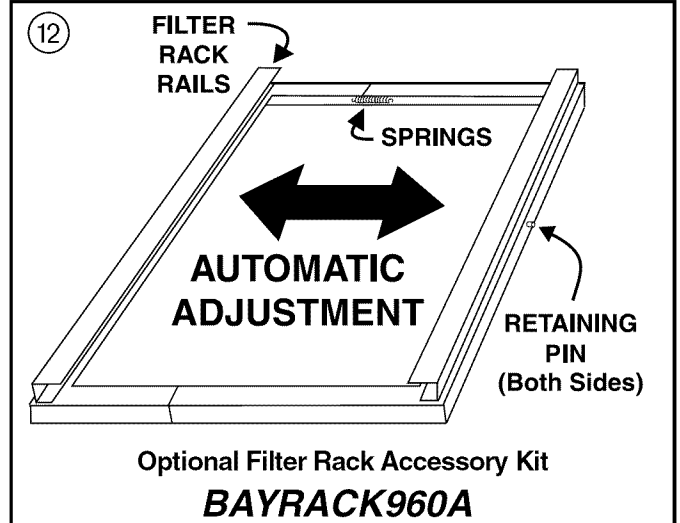

Optional Filter Rack Accessory Kit
BAYRACK960A

OPTIONAL BOTTOM FILTER RACK INSTALLATION

With the filter removed, the filter rack is compressed and then inserted into the bottom of the furnace. The retaining screw/ pin on each side inserts into engagement holes at the bottom of the furnace cabinet side.

OPTIONAL FILTER RACK INSTALLATION FOR SIDE RETURN AIR ON UPFLOW FURNACES (Left or Right)

NOTE:

The optional filter rack installation is not allowed for right side return on the following model: *UX1C080-A9601.

Installer's Guide

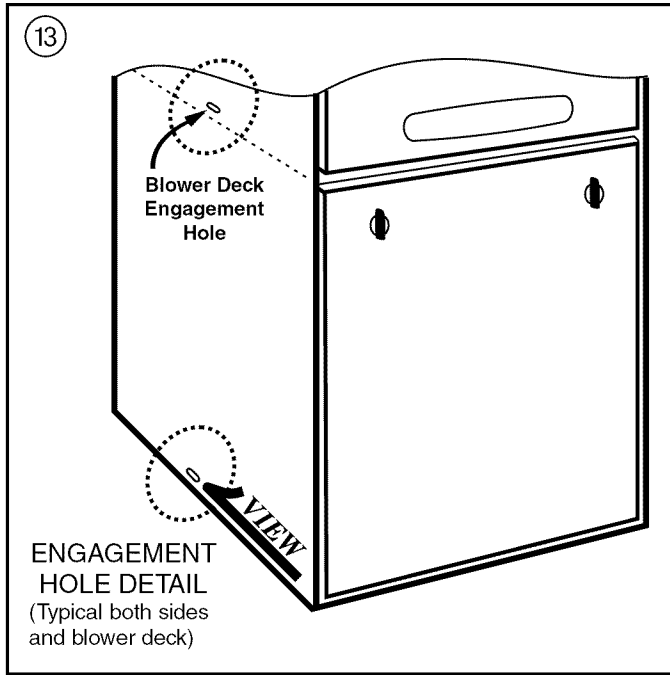

If side air return is desired, the following instructions should be used:

- Open or remove the blower door.
- Leave the bottom panel in place.
- After the side cutout is made following the directions in the "Return Air Duct Connections" section on pages 8 and 9, compress the optional filter rack and reinstall in the side of the furnace. Confirm that the upper retaining pin/screw locks into the engagement hole in the blower deck and the lower pin/screw rests against the side of the bottom panel. See Figures 14 - 18.
- Install the optional furnace filter on the side inserting the chamfer end first.

RETURN AIR FILTERS FOR UPFLOW FURNACE IN HORIZONTAL CONFIGURATION

When the Upflow Furnace is installed in the horizontal configuration, the return air filters must be installed exterior to the cabinet. Remote filter grilles may be used for homeowner convenience or the filters may be installed in the duct work upstream of the furnace. See Figure 20.

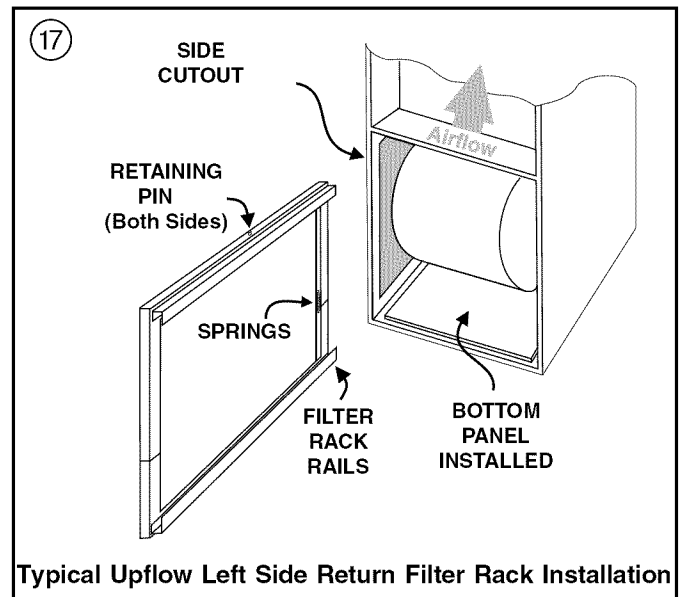
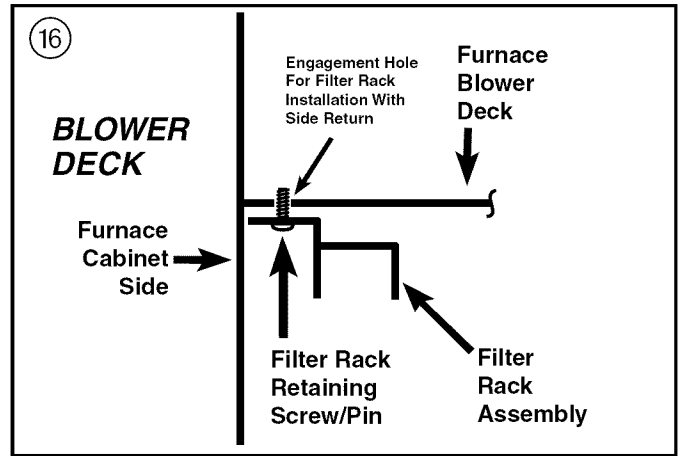
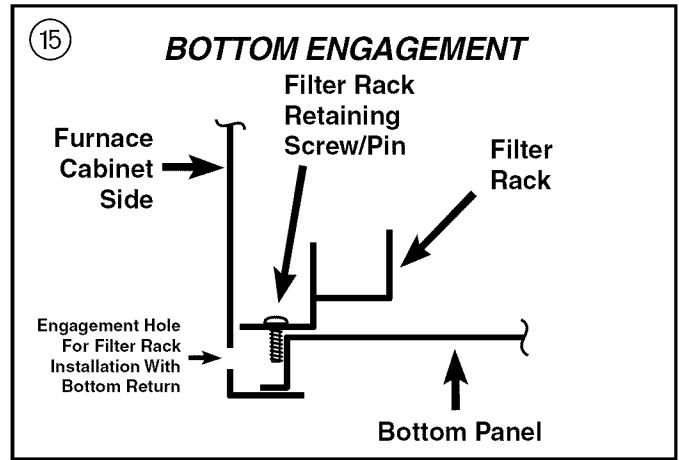
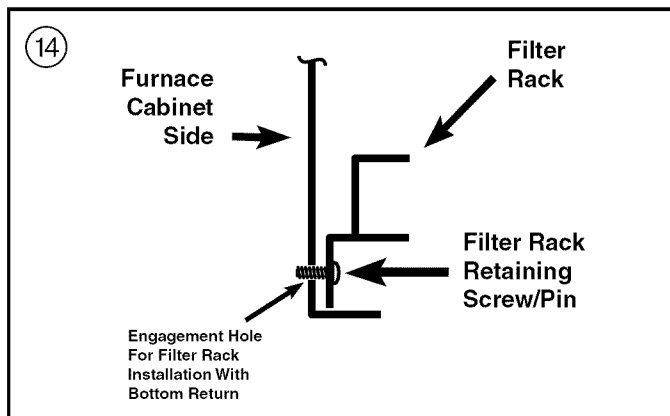

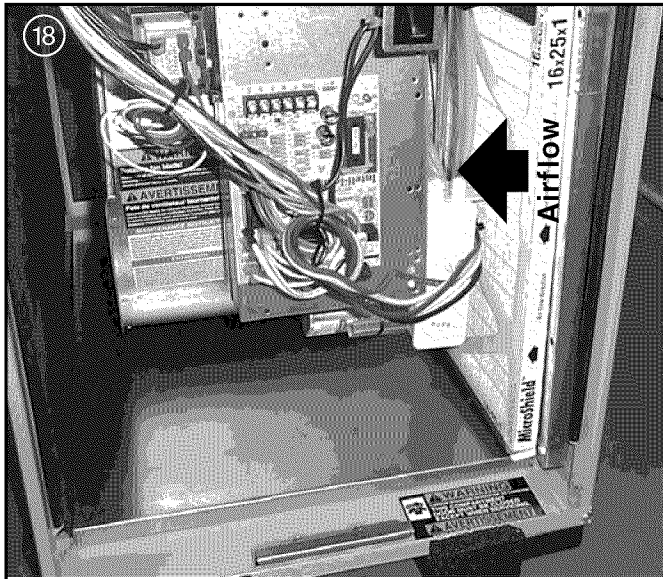

Typical Upflow Right Side Return Filter Rack Installation

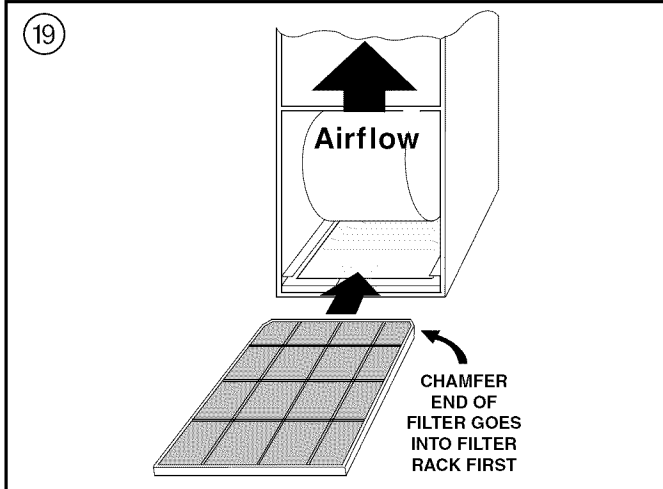

BLOWER DOOR/ HINGE REMOVAL

If clearance or other problems create a problem in using the tilting door, the blower door hinge may be removed without creating any problems with the seal of the furnace. To remove the blower door, tilt the door forward 2 to 3 inches and pull up. To remove the tilt feature, simply remove the lower hinge as shown in Figure 21. The bottom of the blower door will catch in the bottom of the furnace front channel for door replacement.

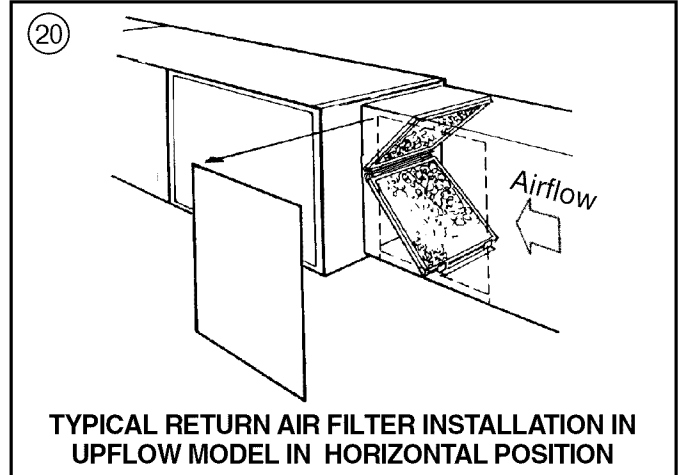

TYPICAL RETURN AIR FILTER INSTALLATION IN UPFLOW MODEL IN HORIZONTAL POSITION

ALTERNATE UPFLOW FILTER CLIP/ BRACKET INSTALLATION

1. Determine the location to be used. The furnace cabinet has dimples for location of the alternate furnace clips (*Side return only*). Pre-drill clearance holes with a 3/16" drill. Bottom return holes are pre-drilled.
2. Install the clips in front and rear of the desired location using the screws provided. The filter clip with the leaf spring mounts in the rear of the cabinet.

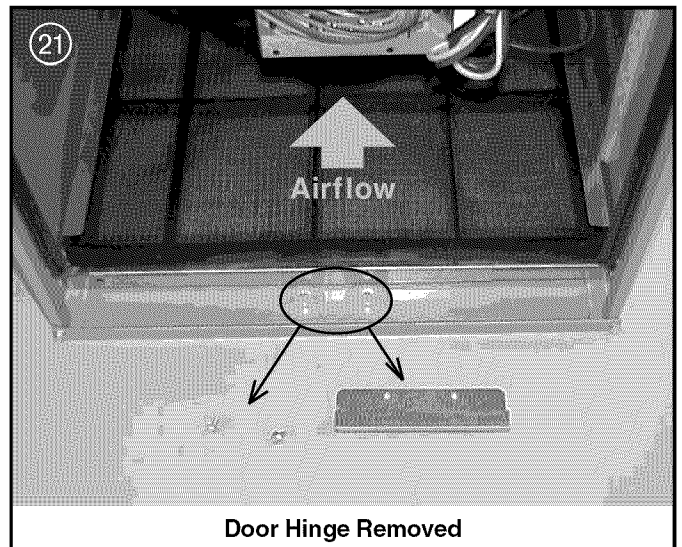

Door Hinge Removed

INSTALLING THE FILTER

The optional filter may need to be cut to fit the unit depending on the location of the return air filter. A score line and the words "CUT HERE" are located on the end of the filter. If your application requires cutting the filter, do so as indicated by the score mark.

Installer's Guide

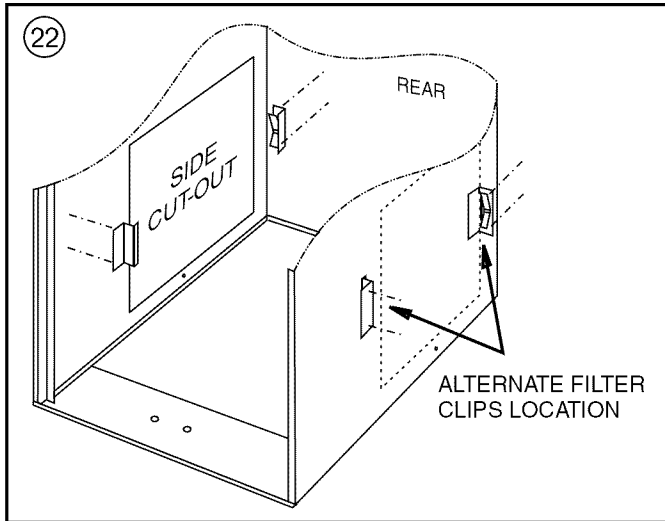

TYPICAL DOWNFLOW FURNACE RETURN AIR FILTER INSTALLATIONS

Two high velocity type air filters are required for each downflow furnace. Downflow furnace filters must be located outside the furnace cabinet. Typical installations are shown in Figure 23. Tables 5 and 6 provide information for installation of the filter retaining brackets with downflow furnaces.

TABLE 4

MODELS NUMBERS	CABINET WIDTH	FILTER QTY & SIZE
*DX1B040A9241A *DX1B060A9361A *DX1B080A9421A	17-1/2"	2 - 14" X 20" X 1"
*DX1C100A9481A	21"	2 - 16" X 20" X 1"
*DX1D120A9601A	24-1/2"	2 - 16" X 20" X 1"

*First letter may be "A" or "T"

UNIT SIZE	RETURN AIR	
	BOTTOM	SIDE
17-1/2"	DO NOT CUT	DO NOT CUT
21"	DO NOT CUT	CUT ON LINE
24-1/2"	DO NOT CUT	CUT ON LINE

TABLE 5

LOCATING FILTER RETAINER BRACKETS IN DUCTWORK

CABINET WIDTH	RETURN DUCT WIDTH	DIMENSION "A"	DIMENSION "B"	FILTER BRACKET LOCATION*
17-1/2"	16-1/4"	15"	14"	14-3/8"
21"	19-3/4"	19-1/2"	14"	13-1/8"
24-1/2"	23-1/4"	22"	14"	13-5/8"

* LOCATION DIMENSION IS FROM END OF DUCT AGAINST THE FURNACE TO THE SCREW HOLES FOR THE BRACKET.

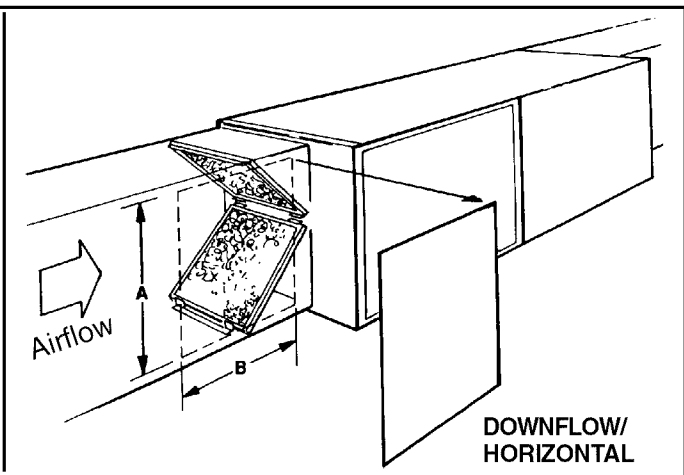
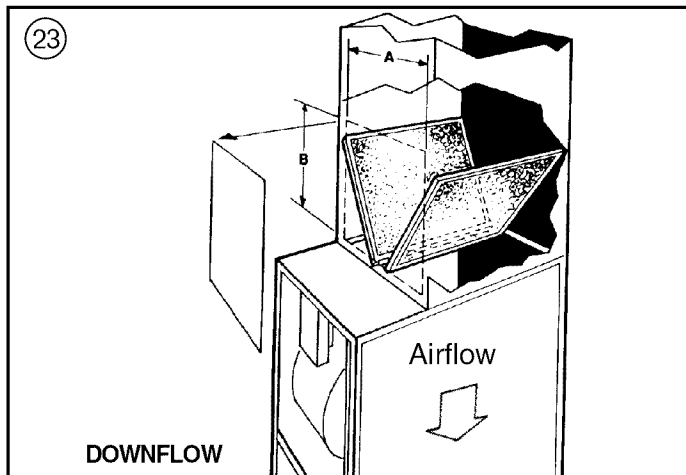

TABLE 6

MINIMUM CLEARANCE FROM COMBUSTIBLE MATERIALS FOR UPFLOW/HORIZONTAL AND DOWNFLOW/ HORIZONTAL FURNACES			
FURNACE SURFACE	UNIT LOCATION		
	VERTICAL CLOSET	HORIZONTAL CLOSET	HORIZONTAL ALCOVE / ATTIC
SIDES	0"	1"	0"
BACK	0"	3"	6"
TOP	1"	1"	1"
FRONT	3"	3"	18"
VENT	0"	0"	0"

NOTE: CLEARANCE REQUIRED AT TOP OF PLENUM IS 1"

GENERAL VENTING

THIS FURNACE MUST BE VENTED TO THE OUTDOORS.

THESE FURNACES ARE INDUCED DRAFT VENTED AND MUST **NOT** BE CONNECTED TO ANY VENT SERVING ANOTHER APPLIANCE. PLEASE NOTE THAT THESE FURNACES USE **POSITIVE-PRESSURE VENT SYSTEMS**.

Proper venting is essential to obtain maximum efficiency from a condensing furnace. Proper installation of the vent system is necessary to assure drainage of the condensate and prevent deterioration of the vent system.

American Gas Association has certified the design of condensing furnaces for a minimum of 0" clearance from combustible materials with a single wall plastic vent pipe.

The recommended system is assembled from 2", 2-1/2", or 3" plastic pipe and fittings (See Table 7, page 14). Where the system is routed to the outdoors through an existing masonry chimney containing flue products from another gas appliance, or where required by local codes, then 3" venting of Type 29-4C stainless steel must be used in place of PVC material.

These furnaces have been classified as CATEGORY IV furnaces in accordance with the latest edition of ANSI Z21.47 • CAN/ CGA-2.3 Standards. Category IV furnaces operate with positive vent pressure and with a vent gas temperature less than 140°F above the dewpoint. These conditions require special venting systems, which must be gas tight and water tight.

NOTE:

When an existing furnace is removed from a venting system serving other gas appliances, the venting system is likely to be too large to properly vent the remaining attached appliances.

IMPORTANT:

*These furnaces may be installed as Direct Vent (sealed combustion) or as Nondirect vent (single pipe). The furnaces are shipped **DIRECT VENT** with sealed combustion.*

For DIRECT VENT APPLICATION: The furnaces must be vented to the exterior of the house and combustion air **MUST** come through the inlet air pipe **FROM OUTSIDE AIR**.

For NONDIRECT VENT APPLICATION: The furnace shall be vented to the exterior of the house, but combustion air may enter from the surrounding area as long as combustion air requirements are met. (See **AIR FOR COMBUSTION AND VENTILATION**)

The following steps shall be followed with each appliance remaining connected to the common venting system placed in operation, while the other appliances remaining connected to the common venting system are not in operation.

1. Seal any unused openings in the common venting system.
2. Visually inspect the venting system for proper size and horizontal pitch and determine there is no blockage or restriction, leakage, corrosion or other deficiencies which could cause an unsafe condition.
3. Insofar as is practical, close all building doors and windows and all doors between the space in which the appliances remaining connected to the common venting system are located and other spaces of the building. Turn on clothes dryers and any appliances not connected to the common venting system. Turn on any exhaust fans, such as range hoods and bathroom exhausts, so they will operate at maximum speed. Do not operate a summer exhaust fan, close fireplace dampers.
4. Follow the lighting instructions. Place the appliance being inspected in operation. Adjust thermostat so appliance will operate continuously.
5. Test for spillage at the draft hood relief opening after 5 minutes of main burner operation. Use the flame of a match or candle, or smoke from a cigarette, cigar, or pipe.
6. After it has been determined that each appliance remaining connected to the common venting system properly vents when tested as outlined above, return door, windows, exhaust fans, fireplace dampers and any other gas-burning appliance to their previous conditions of use.

If improper venting is observed during any of the above tests, the remaining common venting system must be corrected. Correction of the remaining common vent system should be done by referring to the latest edition of the National Fuel Gas Code (ANSI Z223.1) • CAN/ CGA B149.1 Installation Codes or "Exhibit J" of ANSI Z21.47 • CAN/ CGA-2.3 Standards. The following are general steps to be used to correct or resize a remaining vent system when a furnace which may not be common vented is removed from the system:

- a. Determine the Btu per hour input of all remaining appliances attached to the venting system.
- b. Determine the diameter, rise, and lateral of the existing venting system, as well as quantity and type of bends.
- c. Use the appropriate tables in the latest edition of the National Fuel Gas Code (ANSI Z223.1 • CAN/ CGA B149.1 Installation Codes or "Exhibit J" of ANSI Z21.47 • CAN/ CGA-2.3 Standards. "Exhibit J" includes examples and drawings of typical venting systems.

Installer's Guide

PVC VENT FITTING MATERIAL

These fittings are available from your Gas Furnace Distributors.

Straight Pipe Sections, Couplings, 45° Elbows, 60° Elbows, 90° Elbows, Vent or Sanitary Tee, or other necessary fittings may be 2", 2½", 3", or 4" diameter. The allowable materials are shown in Table 7.

VENT FITTING MATERIAL – PLASTIC

Gas and liquid tight single wall vent fittings, designed for resistance to corrosive flue condensate, **MUST** be used throughout.

Listed in Table 8 & 9 are 2", 2½", 3", and 4" size fittings that meet these requirements. The materials listed are various grades of PVC and ABS plastic.

PIPE JOINTS: All joints must be fastened and sealed to prevent escape of combustion products into the building.

NOTE:

It is recommended that the first joints from the furnace be connected and sealed with high temperature RTV. This will enable the pipes to be removed later without cutting.

Be sure to properly support these joints.

BONDING OF PVC

Commercially available solvent cement must be used to join the pipe and fittings. Follow instructions on the container carefully.

Procedure for Cementing Joints:

1. Cut pipe square, remove ragged edges and burrs. Chamfer end of pipe, then clean fitting socket and pipe joint area of all dirt, grease, moisture or chips.

2. After checking pipe and socket for proper fit, wipe socket and pipe with cleaner-primer. Apply a liberal coat of primer to inside surface of socket and outside of pipe.

DO NOT ALLOW PRIMER TO DRY BEFORE APPLYING CEMENT.

3. Apply a thin coat of cement evenly in the socket. Quickly apply a heavy coat of cement to the pipe end and insert pipe into fitting with a slight twisting movement until it bottoms out.
4. Hold the pipe in the fitting for 30 seconds to prevent tapered socket from pushing the pipe out of the fitting.
5. Wipe all excess cement from the joint with a rag. Allow 15 minutes before handling. Cure time varies according to fit, temperature and humidity.

IMPORTANT:

Products installed in Canada must use vent systems that are certified to the Standard for Type BH Gas Venting Systems (ULC S636) for Class II-A venting systems (up to 65°C). Components of the vent system must not be interchanged with other vent systems or unlisted pipe or fittings. Plastic components, specified primers, and glues must be from a single system manufacturer and not intermixed with other system manufacturer's vent system parts. In addition, the first three feet of the vent pipe must be visible for inspection.

TABLE 7

PLASTIC PIPE DESIGNATIONS			
PVC			
ASTM STANDARD	PIPE TYPE	ALLOWABLE TEMPERATURE	MARKING
F891	CELLULAR CORE	*158	ASTM F891
D2665	DWV PIPE	**158	ASTM D2665
D1785	SCH 40, 80, 120	**158	ASTM D1785
D2241	SDR SERIES	**158	ASTM D2241
CPVC			
ASTM STANDARD	PIPE TYPE	ALLOWABLE TEMPERATURE	MARKING
D2846	CPVC 41	**212	ASTM D2846
F441	SCH 40, 80	**212	ASTM F441
F442	SDR SERIES	**212	ASTM F442
ABS			
ASTM STANDARD	PIPE TYPE	ALLOWABLE TEMPERATURE	MARKING
D2661	SCH 40 DWV	***180	ASTM D2661
F628	SCH 40 DWV CELLULAR CORE	***180	ASTM F628
* - Allowable temperatures based on classifications covered in ASTM D4396 [Deflection Temps Under Load (264 PSI)]			
** - Allowable temperatures based on classifications covered in ASTM D1784 [Deflection Temps Under Load (264 PSI)]			
*** - Allowable temperatures based on classifications covered in ASTM D3965 [Deflection Temps Under Load (264 PSI)]			

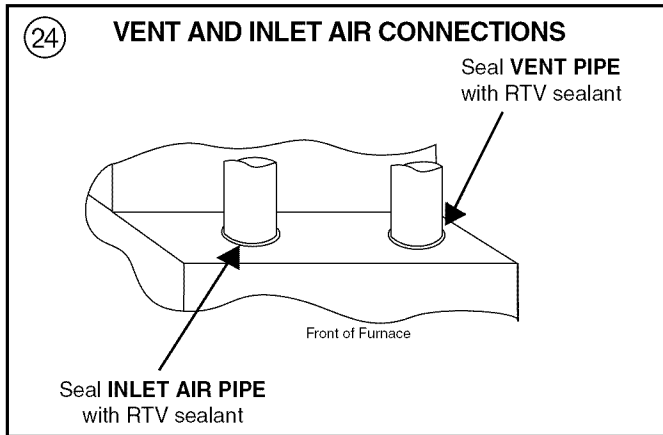

NOTE:
Follow venting instructions carefully when using PVC cement.

IMPORTANT:
All joints must be water tight. Flue condensate is somewhat acidic, and leaks can cause equipment damage.

Connection of the pipe and collar of the **combustion air inlet** should just be a friction fit. It is recommended that the inlet air joint be sealed with RTV type sealant to allow the joint to be separated for possible future service. The inlet and vent pipes must be properly supported throughout the entire length.

Connection of the **vent pipe** to the vent collar should also be accomplished using RTV type sealant. This type sealant provides a connection which remains flexible and can be separated in the future if service needs require the removal of the vent pipe for service or clearance.

NOTE:
To ensure proper operation at the vent lengths indicated, the combustion air inlet and vent terminals should be in the same pressure zone. Terminating the vent and inlet in different pressure zones will change the maximum vent lengths and may cause nuisance tripping of the pressure switch(es). The amount of change can not be predicted. The selection of the inlet and outlet terminal locations are the responsibility of the designer/installer. If the installer chooses separate pressure zones for the terminals, the combustion air inlet termination must be in the higher (more positive) pressure zone.

UPFLOW/ HORIZONTAL VENTING TABLE
TABLE 8

MAXIMUM VENT LENGTH:								
MODEL	DIRECT VENT (2 PIPE SYSTEM) - MAXIMUM TOTAL EQUIVALENT FEET FOR VENT AND INLET AIR PIPES (See Notes)				NONDIRECT VENT (1 PIPE SYSTEM) -MAXIMUM TOTAL EQUIVALENT FEET FOR VENT PIPE ONLY (See Notes)			
	2" PIPE & FITTINGS	2-1/2" PIPE & FITTINGS	3" PIPE & FITTINGS	4" PIPE & FITTINGS	2" PIPE & FITTINGS	2-1/2" PIPE & FITTINGS	3" PIPE & FITTINGS	4" PIPE & FITTINGS
*UX1B040A9241A	60	80	100	130	50	80	80	130
*UX1B060A9241A	60	80	100	130	50	80	80	130
*UX1B060A9361A	60	80	100	130	50	80	80	130
*UX1B080A9241A	50	80	100	130	40	80	80	130
*UX1B080A9421A	50	80	100	130	40	80	80	130
*UX1C080A9601A	NOT ALLOWED	60	100	130	NOT ALLOWED	60	80	130
*UX1C100A9361A	NOT ALLOWED	40	100	130	NOT ALLOWED	40	80	130
*UX1C100A9481A	NOT ALLOWED	40	100	130	NOT ALLOWED	40	80	130
*UX1D100A9601A	NOT ALLOWED	40	100	130	NOT ALLOWED	40	80	130
*UX1D120A9601A	NOT ALLOWED	15	60	130	NOT ALLOWED	25	70	130

NOTES: * - First letter may be "A" or "T"

- The INLET AIR of one pipe systems require the installation of a 90° elbow (to prevent dust and debris from falling straight into the furnace) and a 2 foot horizontal or vertical straight pipe section connected before or after the elbow.
- DO NOT MIX PIPE DIAMETERS IN THE SAME LENGTH OF PIPE OUTSIDE THE FURNACE CABINET (Except adapters at the top of the furnace). If different inlet and vent pipe sizes are used, the vent pipe must adhere to the maximum length limit shown in the table above (See Note 7 below for exception). The inlet pipe can be of a larger diameter, but never smaller than the vent pipe.
- MAXIMUM PIPE LENGTHS MUST NOT BE EXCEEDED! THE LENGTH SHOWN IS NOT A COMBINED TOTAL, IT IS THE MAXIMUM LENGTH OF EACH (Vent or Inlet air pipes in two pipe systems).
- One standard radius 90° elbow is equivalent to 12' of 4" pipe; one SHORT radius 90° elbow is equivalent to 10' of 3" pipe and one LONG radius elbow is equivalent to 6' of 3" pipe. One SHORT/LONG radius 90° elbow is equivalent to 7½' of 2½" pipe, & 5' of 2" pipe. Two 45° elbows equal one 90° elbow.
- The termination tee or bend must be included in the total number of elbows. If the BAYVENT100 termination kit is used, the equivalent length of pipe is 5 feet. There is zero equivalent length for the BAYVENT200.
- Pipe adapters are field supplied.
- 4" pipe may be reduced to 3" for termination with BAYAIR30AVENTA or BAYVENT200 without additional length restriction.

Installer's Guide

DOWNFLOW/HORIZONTAL VENTING TABLE
TABLE 9

MAXIMUM VENT LENGTH:								
MODEL	DIRECT VENT (2 PIPE SYSTEM) - MAXIMUM TOTAL EQUIVALENT FEET FOR VENT AND INLET AIR PIPES (See Notes)				NONDIRECT VENT (1 PIPE SYSTEM) - MAXIMUM TOTAL EQUIVALENT FEET FOR VENT PIPE ONLY (See Notes)			
	2" PIPE & FITTINGS	2-1/2" PIPE & FITTINGS	3" PIPE & FITTINGS	4" PIPE & FITTINGS	2" PIPE & FITTINGS	2-1/2" PIPE & FITTINGS	3" PIPE & FITTINGS	4" PIPE & FITTINGS
*DX1B040A9241A	60	80	100	130	50	80	80	130
*DX1B060A9361A	50	80	100	130	50	80	80	130
*DX1B080A9421A	45	80	100	130	40	80	80	130
*DX1C100A9481A	NOT ALLOWED	80	100	130	NOT ALLOWED	80	80	130
*DX1D120A9601A	NOT ALLOWED	15	60	130	NOT ALLOWED	25	70	130

- NOTES:** * - First letter may be "A" or "T"
- The INLET AIR of one pipe systems require the installation of a 90° elbow (to prevent dust and debris from falling straight into the furnace) and a 2 foot horizontal or vertical straight pipe section connected before or after the elbow.
 - DO NOT MIX PIPE DIAMETERS IN THE SAME LENGTH OF PIPE OUTSIDE THE FURNACE CABINET (Except adapters at the top of the furnace). If different inlet and vent pipe sizes are used, the vent pipe must adhere to the maximum length limit shown in the table above (See Note 7 below for exception). The inlet pipe can be of a larger diameter, but never smaller than the vent pipe.
 - MAXIMUM PIPE LENGTHS MUST NOT BE EXCEEDED! THE LENGTH SHOWN IS NOT A COMBINED TOTAL, IT IS THE MAXIMUM LENGTH OF EACH (Vent or Inlet air pipes in two pipe systems).
 - One standard radius 90° elbow is equivalent to 12' of 4" pipe; one SHORT radius 90° elbow is equivalent to 10' of 3" pipe and one LONG radius elbow is equivalent to 6' of 3" pipe. One SHORT/LONG radius 90° elbow is equivalent to 7½' of 2½" pipe, & 5' of 2" pipe. Two 45° elbows equal one 90° elbow.
 - The termination tee or bend must be included in the total number of elbows. If the BAYVENT100 termination kit is used, the equivalent length of pipe is 5 feet. There is zero equivalent length for the BAYVENT200.
 - Pipe adapters are field supplied.
 - 4" pipe may be reduced to 3" for termination with BAYAIR30AVENTA or BAYVENT200 without additional length restriction.

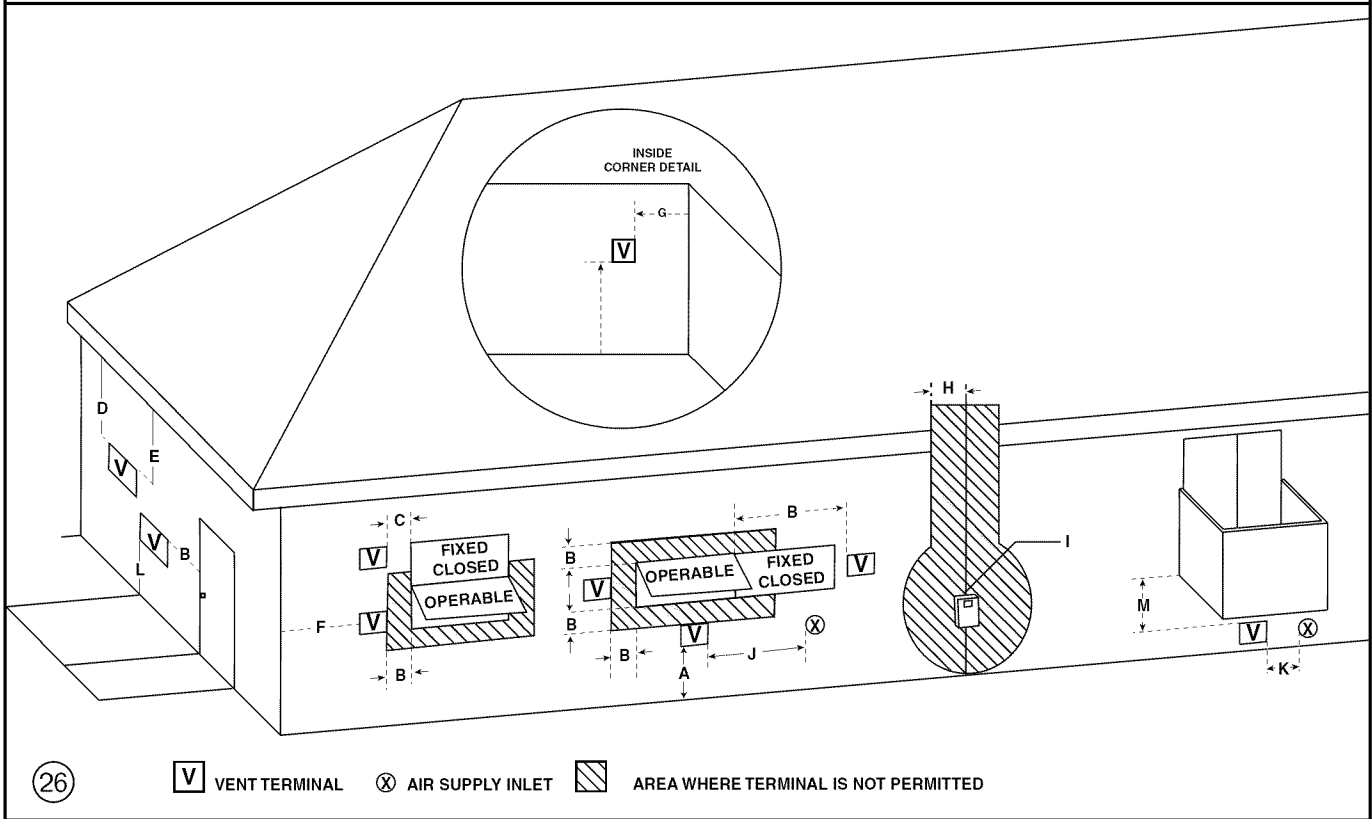
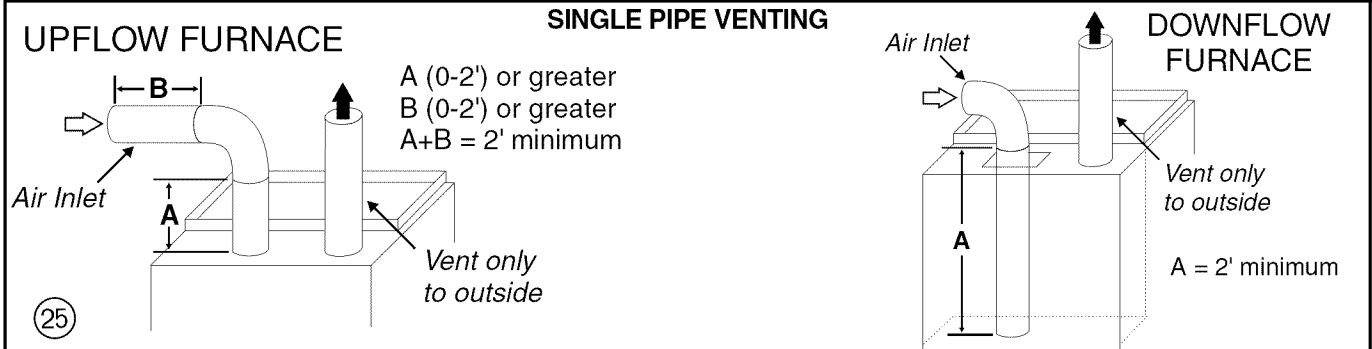

Installer's Guide

Direct Vent Terminal Clearances			
		Canadian Installations	US Installations
A=	Clearance above grade, veranda, porch, deck, or balcony	12 inches (30 cm)	12 inches (30 cm)
B=	Clearance to window or door that may be opened	6 inches (15 cm) for appliances \leq 10,000 Btuh (3 kw), 12 inches (30 cm) for appliances > 10,000 Btuh (3 kw) and \leq 100,000 Btuh (30 kw), 36 inches (91 cm) for appliances > 100,000 Btuh (30 kw)	6 inches (15 cm) for appliances \leq 10,000 Btuh (3 kw), 9 inches (23 cm) for appliances > 10,000 Btuh (3 kw) and \leq 50,000 Btuh (15 kw), 12 inches (30 cm) for appliances > 50,000 Btuh (15 kw)
C=	Clearance to permanently closed window	*	*
D=	Vertical clearance to ventilated soffit located above the terminal within a horizontal distance of 2 feet (61 cm) from the center line of the terminal	*	*
E=	Clearance to unventilated soffit	*	*
F=	Clearance to outside corner	*	*
G=	Clearance to inside corner	*	*
H=	Clearance to each side of center line extended above meter/regulator assembly	3 feet (91 cm) with a height 15 feet (4.5 m) above the meter/regulator assembly	*
I=	Clearance to service regulator vent outlet	3 feet (91 cm)	*
J=	Clearance to nonmechanical air supply inlet to building or the combustion air inlet to any other appliance	6 inches (15 cm) for appliances \leq 10,000 Btuh (3 kw), 12 inches (30 cm) for appliances > 10,000 Btuh (3 kw) and \leq 100,000 Btuh (30 kw), 36 inches (91 cm) for appliances > 100,000 Btuh (30 kw)	6 inches (15 cm) for appliances \leq 10,000 Btuh (3 kw), 9 inches (23 cm) for appliances > 10,000 Btuh (3 kw) and \leq 50,000 Btuh (15 kw), 12 inches (30 cm) for appliances > 50,000 Btuh (15 kw)
K=	Clearance to a mechanical air supply inlet	6 feet (1.83m)	3 feet (91 cm) above if within 10 feet (3m) horizontally
L=	Clearance above a paved sidewalk or paved driveway located on public property	7 feet (2.13 m) †	*
M=	Clearance under veranda, porch, deck, or balcony	12 inches (30 cm) ‡	*

Notes:

- In accordance with the current CSA B149.1 Natural Gas and Propane Installation Code.
- In accordance with the current ANSI Z223.1/NFPA 54 National Fuel Gas Code.

†. A vent shall not terminate directly above a sidewalk or paved driveway that is located between two single family dwelling and serves both dwellings.
‡. Permitted only if veranda, porch, deck, or balcony is fully open on a minimum of two sides beneath the floor.
* Clearance in accordance with local installation codes and the requirements of the gas supplier and the manufacturer's Installation Instructions.

Non-Direct Vent Terminal Clearances			
		Canadian Installations	US Installations
A=	Clearance above grade, veranda, porch, deck, or balcony	12 inches (30 cm)	12 inches (30 cm)
B=	Clearance to window or door that may be opened	6 inches (15 cm) for appliances \leq 10,000 Btuh (3 kw), 12 inches (30 cm) for appliances > 10,000 Btuh (3 kw) and \leq 100,000 Btuh (30 kw), 36 inches (91 cm) for appliances > 100,000 Btuh (30 kw)	4 feet (1.2m) below or to the side of opening; 1 foot (0.3m) above opening.
C=	Clearance to permanently closed window	*	*
D=	Vertical clearance to ventilated soffit located above the terminal within a horizontal distance of 2 feet (61 cm) from the center line of the terminal	*	*
E=	Clearance to unventilated soffit	*	*
F=	Clearance to outside corner	*	*
G=	Clearance to inside corner	*	*
H=	Clearance to each side of center line extended above meter/regulator assembly	3 feet (91 cm) with a height 15 feet (4.5 m) above the meter/regulator assembly	*
I=	Clearance to service regulator vent outlet	3 feet (91 cm)	*
J=	Clearance to nonmechanical air supply inlet to building or the combustion air inlet to any other appliance	6 inches (15 cm) for appliances \leq 10,000 Btuh (3 kw), 12 inches (30 cm) for appliances > 10,000 Btuh (3 kw) and \leq 100,000 Btuh (30 kw), 36 inches (91 cm) for appliances > 100,000 Btuh (30 kw)	4 feet (1.2 m) below or to side of opening; 1 foot (300 m) above opening
K=	Clearance to a mechanical air supply inlet	6 feet (1.83m)	3 feet (91 cm) above if within 10 feet (3m) horizontally
L=	Clearance above a paved sidewalk or paved driveway located on public property	7 feet (2.13 m) †	7 feet (2.13 m)
M=	Clearance under veranda, porch, deck, or balcony	12 inches (30 cm) ‡	*

Notes:

- In accordance with the current CSA B149.1 Natural Gas and Propane Installation Code.
- In accordance with the current ANSI Z223.1/NFPA 54 National Fuel Gas Code.

†. A vent shall not terminate directly above a sidewalk or paved driveway that is located between two single family dwelling and serves both dwellings.
‡. Permitted only if veranda, porch, deck, or balcony is fully open on a minimum of two sides beneath the floor.
* Clearance in accordance with local installation codes and the requirements of the gas supplier and the manufacturer's Installation Instructions.

Installer's Guide

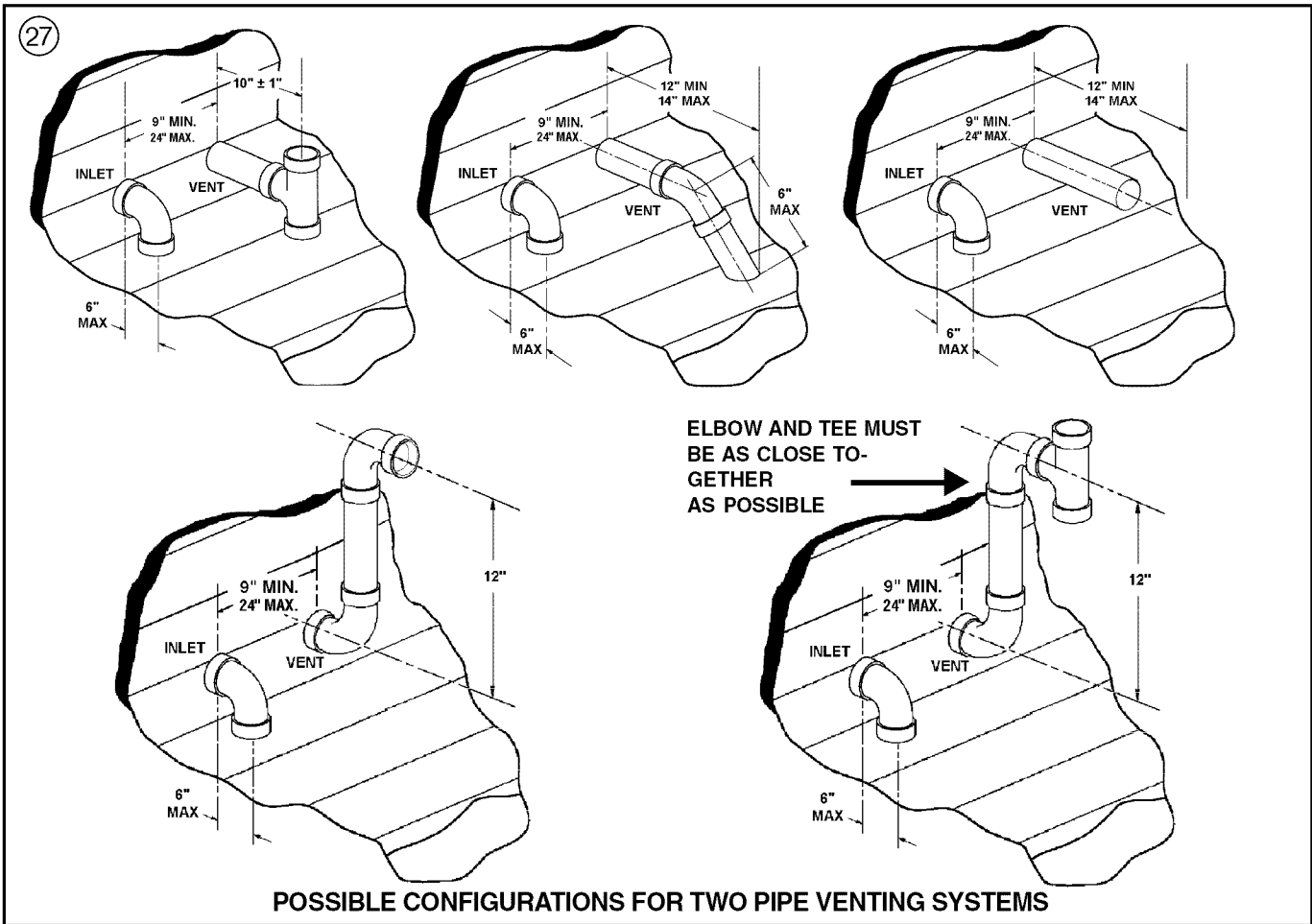

HORIZONTAL VENTING

NOTE:
Vent termination kit **BAYAIR30AVENTA** or **BAYVENT200B** may be used instead of the horizontal and vertical termination options shown in the following figures.

CAUTION

When the vent pipe is exposed to temperatures below freezing, i.e., when it passes through unheated spaces, etc., the pipe must be insulated with 1/2 inch (22.7 mm) thick Armaflex-type insulation or equal. If the space is heated sufficiently to prevent freezing, then the insulation would not be required. If domestic water pipes are not protected from freezing then it is assumed the space meets the condition of a heated space.

HORIZONTAL VENTING THROUGH WALL

These furnaces may be installed as direct vent (as shipped) or as nondirect vent. Installation must conform to national, state, and local codes.

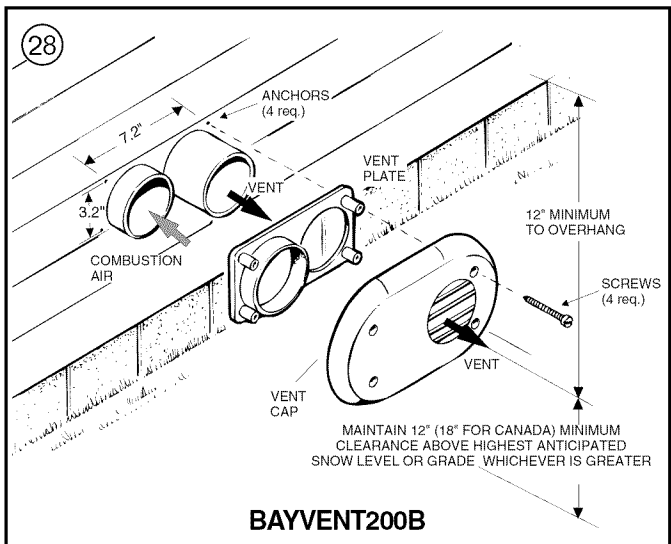

The vent & inlet terminals must be located at least 12" minimum above normally expected snow accumulation level.

Avoid areas where staining or condensate drippage may be a problem.

Location of the vent/ wind terminal should be chosen to meet the requirements of Figure 26 for either direct or non-direct vent applications.

PITCH - Venting through the wall must maintain 1/4" per foot pitched upward to insure that condensate drains back to the furnace.

FLUE GAS DEGRADATION - The moisture content of the flue gas may have a detrimental effect on some building materials. This can be avoided by using the roof or chimney venting option. When wall venting is used on any surface that can be affected by this moisture, it is recommended that a corrosion resistant shield (24 inches square) be used behind the vent termi-

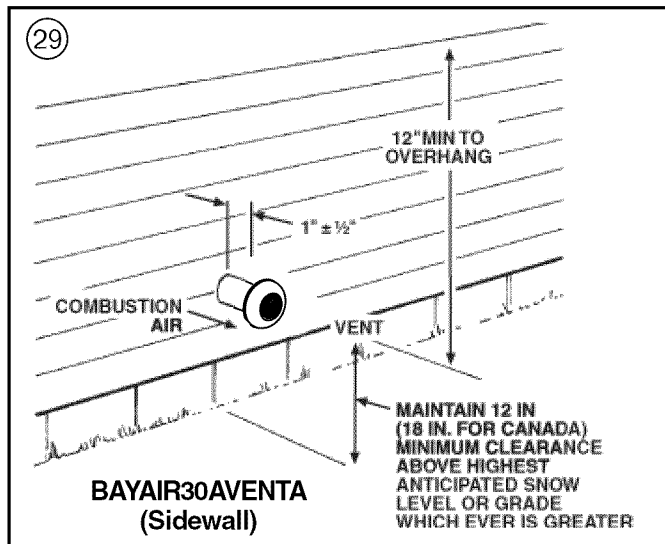

nal. This shield can be wood, plastic, sheet metal, etc. Also, silicone caulk all cracks, seams and joints within 3 feet of the vent terminal.

COMBUSTIBLE MATERIAL WALL

A minimum clearance of 1" to combustible materials must be maintained when using single wall stainless steel venting. See Figure 30 above.

Shield material to be a minimum of 24 gauge stainless or aluminized sheet metal. Minimum dimensions are 12"x12". Shield must be fastened to both inside and outside of wall. Use screws or anchor type fasteners suited to the outside or inside wall surfaces.

NONCOMBUSTIBLE MATERIAL WALL

The hole through the wall must be large enough to maintain pitch of vent and properly seal.

Use cement mortar seal on inside and outside of wall. See Figure 31.

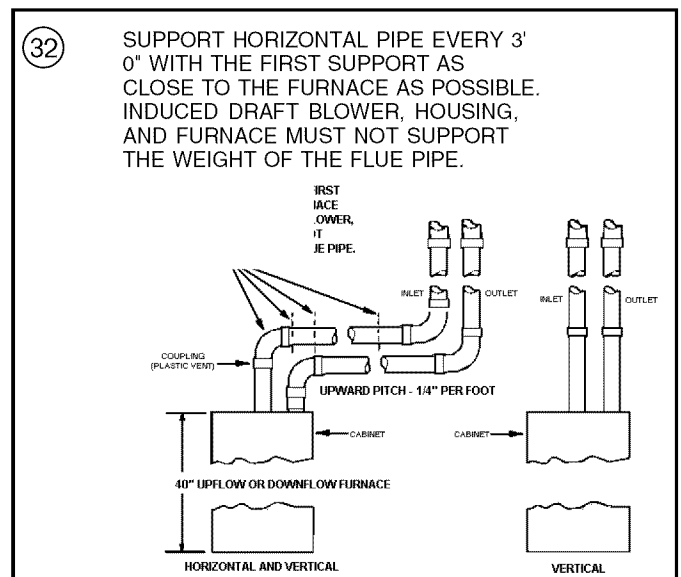
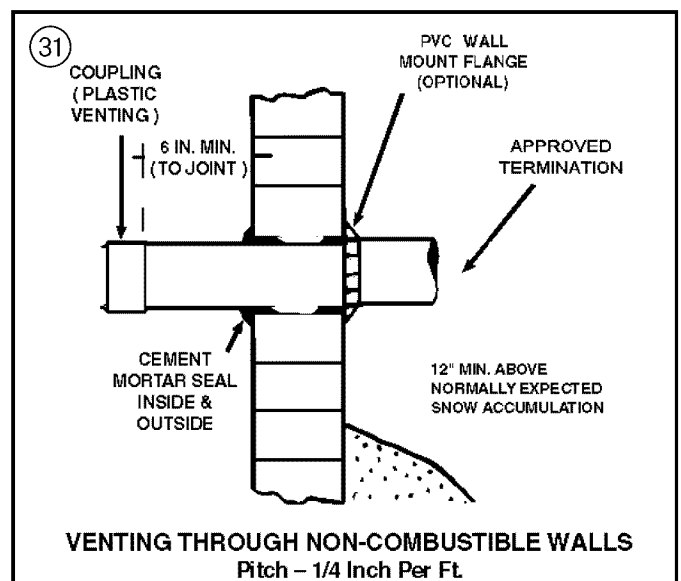
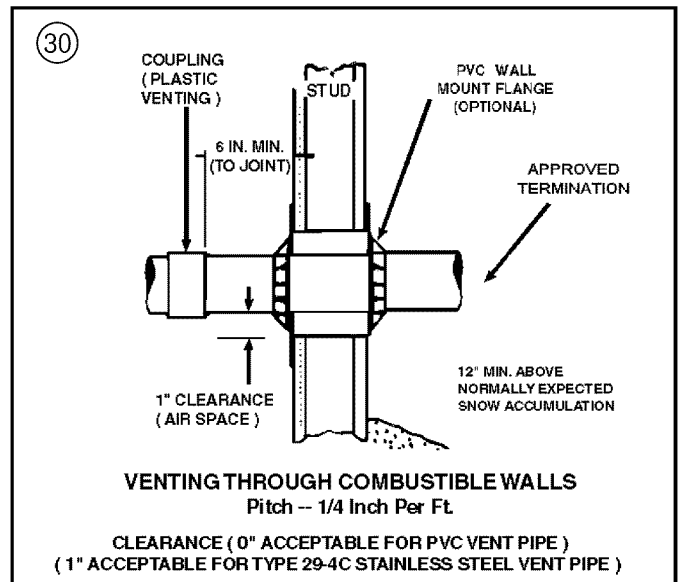

Installer's Guide

33

NOTE: VENT AND INLET MUST BE SUPPORTED AT A MAXIMUM OF 3' INTERVALS

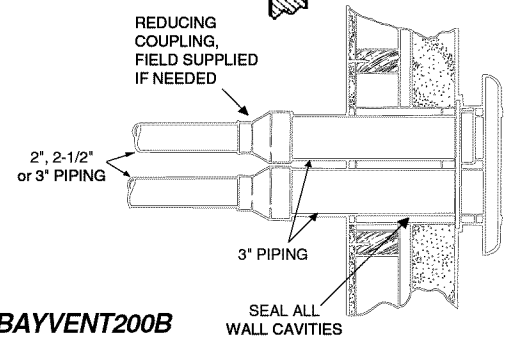
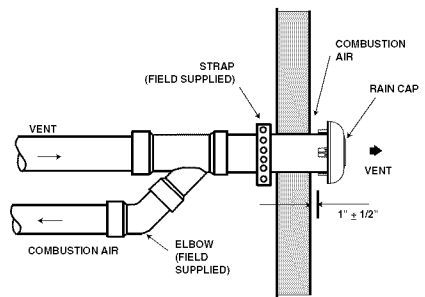
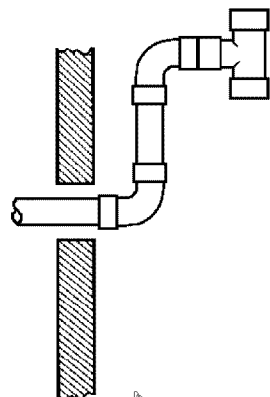
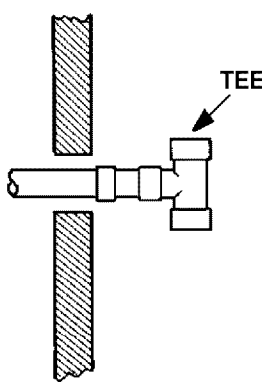
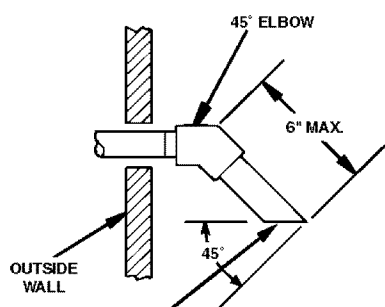
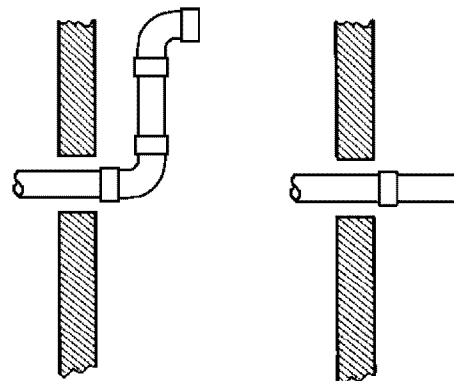
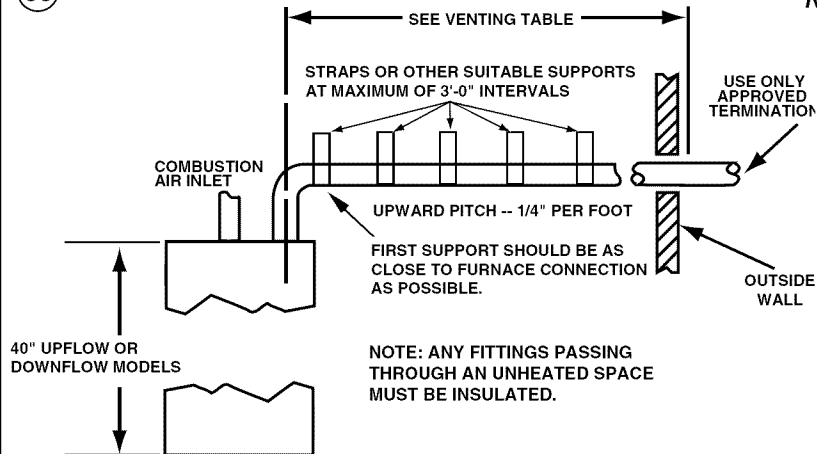

BAYAIR30AVENTA

BAYVENT200B

DOWNWARD VENTING

Furnace may be in vertical or horizontal configuration.

34

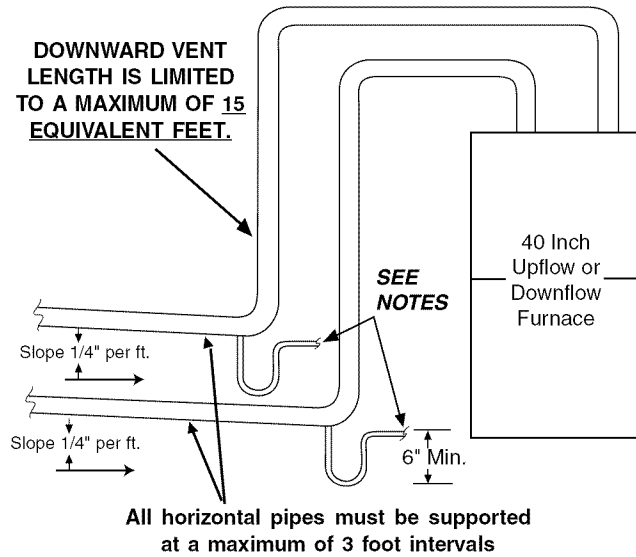

NOTES:

- Condensate trap for vent pipe must be a minimum of 6 inches in height.
- Condensate trap for vent and inlet pipe must be connected into a condensate drain pump; an open or vented drain; or it can be connected to the outlet hose of the furnace's condensate trap. Outdoor draining of the furnace and coil condensate is permissible if allowed by local codes. Caution should be taken to prevent drains from freezing or causing slippery conditions that could lead to personal injury. Excessive draining of condensate may cause saturated ground conditions that may result in damage to plants.
- The condensate trap should be primed at initial start up prior to heating season operation.

VENTING THROUGH THE ROOF

When penetrating roof with a 2" PVC vent pipe, a 2" electrical conduit flashing may be used for a weather tight seal. Lubricate flexible seal on flashing before PVC pipe is pushed through the seal. (Field Supplied)

NOTE:

No vent cap as shown in Figure 35 is the preferred method for vertical vent termination in extremely cold climates.

In extreme climate conditions, insulate the exposed pipe above the roof line with Armaflex type insulation.

VENTING ROUTED THROUGH A MASONRY CHIMNEY

VENT FITTING MATERIAL – STAINLESS STEEL

Gas and liquid tight single wall metal vent fitting, designed for resistance to corrosive flue condensate such as Type 29-4C MUST be used throughout.

These fittings and fitting accessories are to be supplied locally.

DIRECTION OF STAINLESS STEEL FITTING

All stainless steel fitting must be installed with male end towards the furnace.

All horizontal stainless steel sections must be positioned with the seam on top.

All long horizontal sections must be supported to prevent sagging.

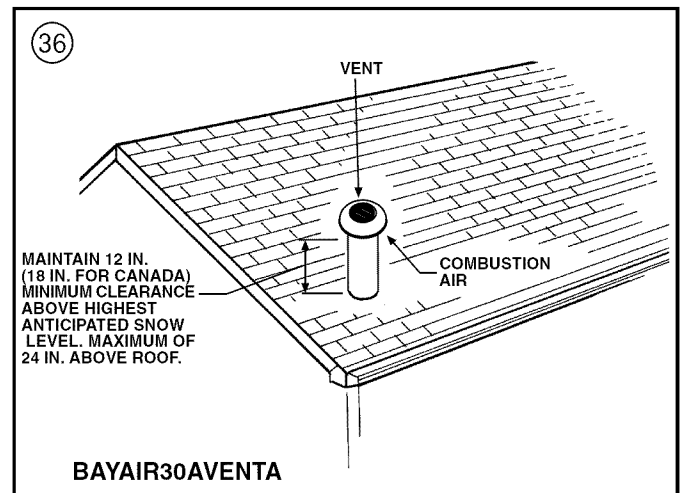
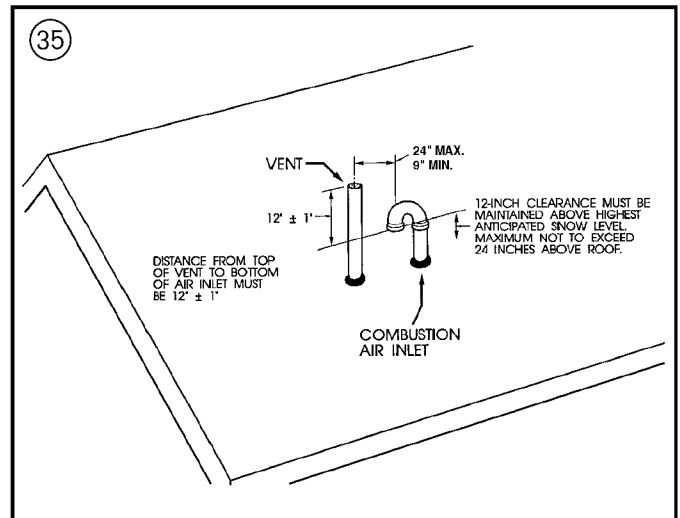

BAYAIR30AVENTA

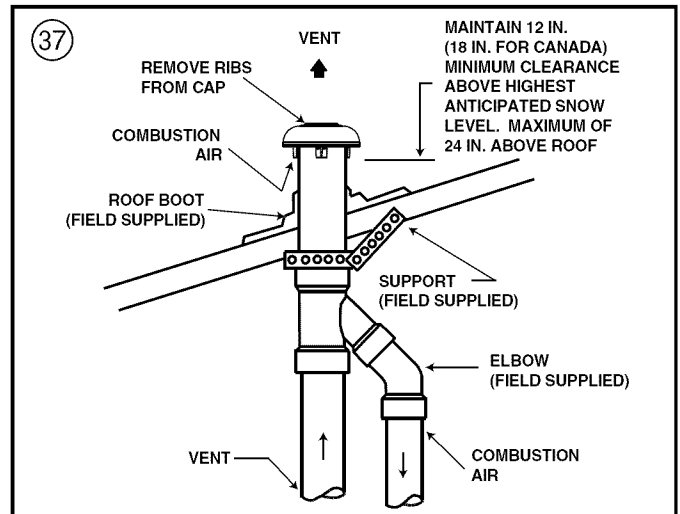

Installer's Guide

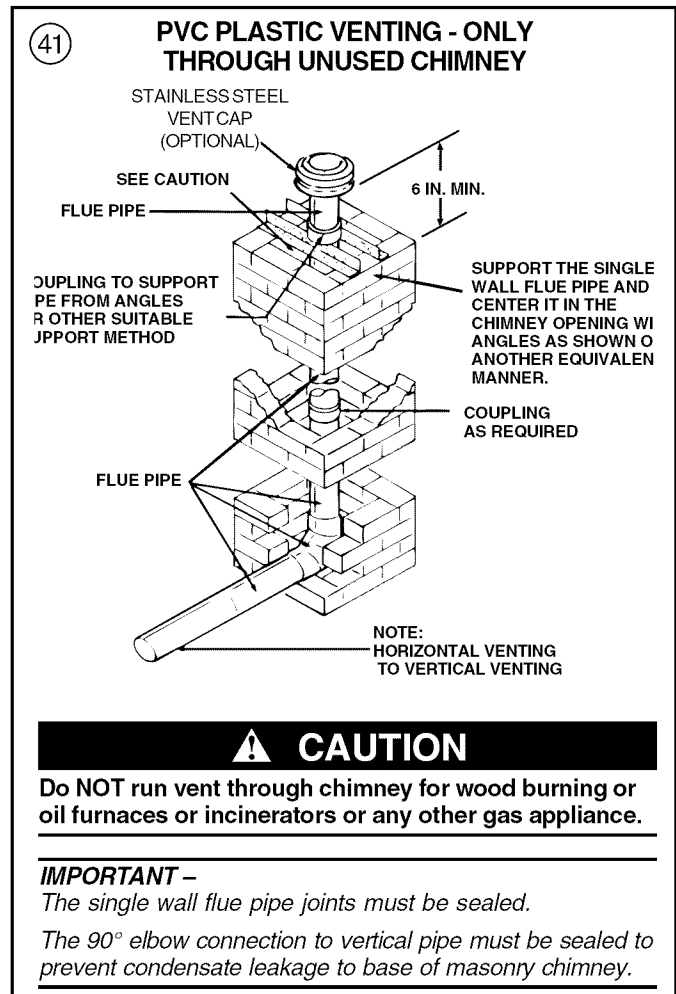
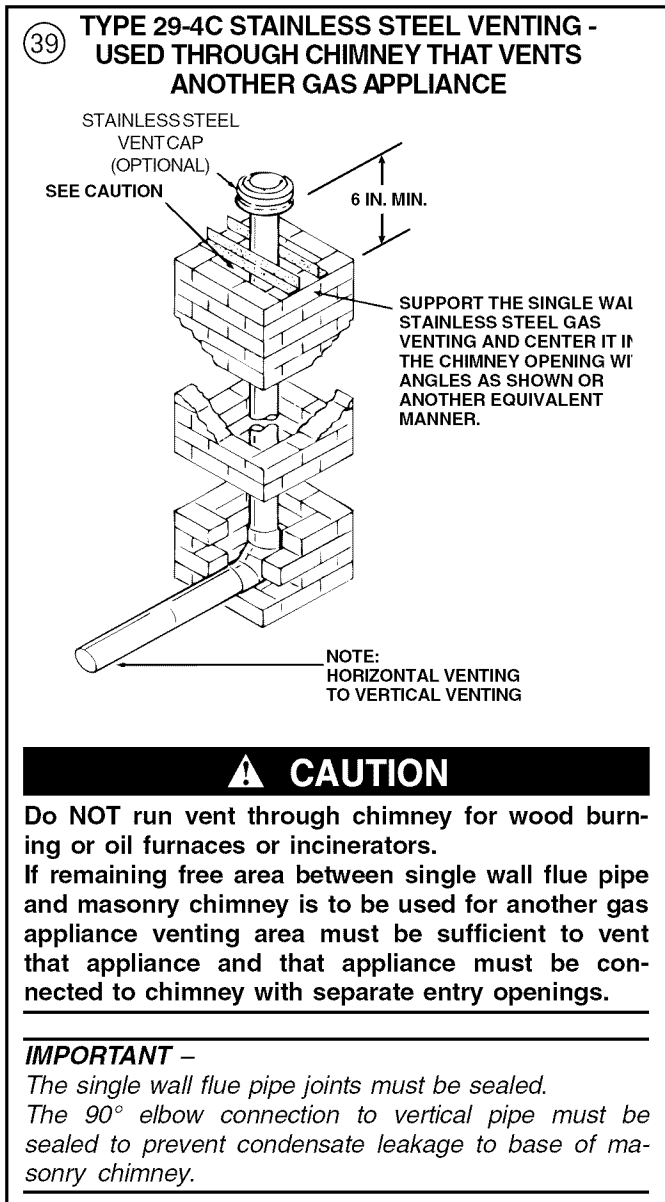
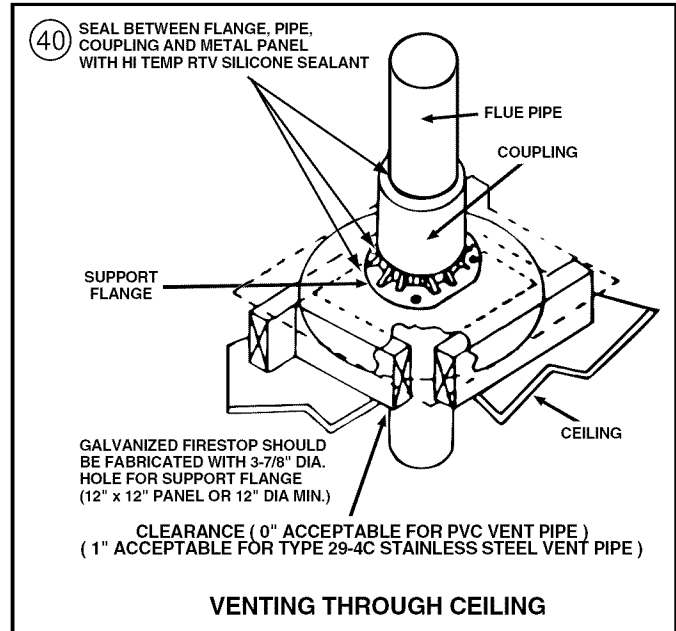
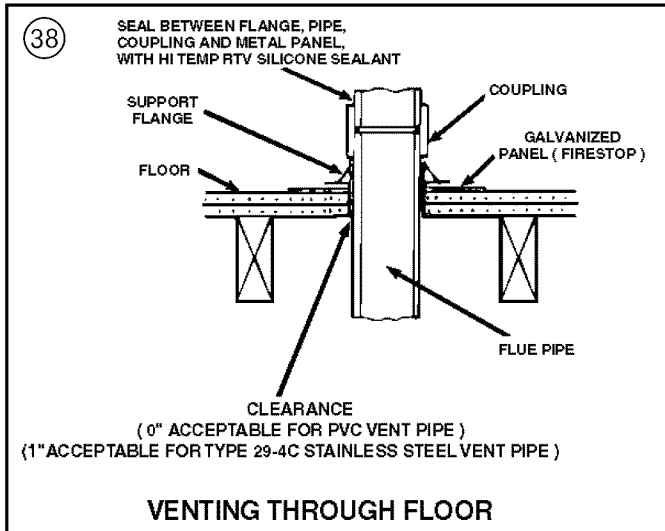

IMPORTANT:

The Commonwealth of Massachusetts requires compliance with regulation 248 CMR 4.00 and 5.00 for installation of through – the – wall vented gas appliances as follows:

For all side wall horizontally vented gas fueled equipment installed in every dwelling, building or structure used in whole or in part for residential purposes, including those owned or operated by the Commonwealth and where the side wall exhaust vent termination is less than seven (7) feet above finished grade in the area of the venting, including but not limited to decks and porches, the following requirements shall be satisfied:

1. **INSTALLATION OF CARBON MONOXIDE DETECTORS.** At the time of installation of the side wall horizontal vented gas fueled equipment, the installing plumber or gasfitter shall observe that a hard wired carbon monoxide detector with an alarm and battery back-up is installed on the floor level where the gas equipment is to be installed. In addition, the installing plumber or gasfitter shall observe that a battery operated or hard wired carbon monoxide detector with an alarm is installed on each additional level of the dwelling, building or structure served by the side wall horizontal vented gas fueled equipment. It shall be the responsibility of the property owner to secure the services of qualified licensed professionals for the installation of hard wired carbon monoxide detectors

a. In the event that the side wall horizontally vented gas fueled equipment is installed in a crawl space or an attic, the hard wired carbon monoxide detector with alarm and battery back-up may be installed on the next adjacent floor level.

b. In the event that the requirements of this subdivision can not be met at the time of completion of installation, the owner shall have a period of thirty (30) days to comply with the above requirements; provided, however, that during said thirty (30) day period, a battery operated carbon monoxide detector with an alarm shall be installed.

2. **APPROVED CARBON MONOXIDE DETECTORS.** Each carbon monoxide detector as required in accordance with the above provisions shall comply with NFPA 720 and be ANSI/UL 2034 listed and IAS certified.

3. **SIGNAGE.** A metal or plastic identification plate shall be permanently mounted to the exterior of the building at a minimum height of eight (8) feet above grade directly in line with the exhaust vent terminal for the horizontally vented gas fueled heating appliance or equipment. The sign shall read, in print size no less than one-half (1/2) inch in size, "GAS VENT DIRECTLY BELOW. KEEP CLEAR OF ALL OBSTRUCTIONS".

4. **INSPECTION.** The state or local gas inspector of the side wall horizontally vented gas fueled equipment shall not approve the installation unless, upon inspection, the inspector observes carbon monoxide detectors and signage installed in accordance with the provisions of 248 CMR 5.08(2)(a)1 through 4.

This appliance requires a special venting system. If BAYAIR30AVENTA or BAYVENT200B are used, a copy of the installation instructions for the kit shall remain with the appliance or equipment at the completion of installation. The venting system installation instructions can be obtained from the manufacturer by writing to the following address:

American Standard, Inc.
6200 Troup Highway
Tyler, TX 75707
Attention: Manager of Field Operations Excellence

Installer's Guide

HORIZONTAL INSTALLATION (Upflow/ Horizontal or Downflow/ Horizontal)

NOTE:
In horizontal venting when the factory supplied "off-set" (2X3 reducing coupling) is used for 3" vent pipe installation, make sure the marking "Top" is located on the top side of the pipe. The straight side must be on bottom for proper condensate drainage. This coupling is factory supplied only with the following models: *UC120 & *DC120, *UX120 & *UY120 *UX100 & *UY100, *UX808C960, and all *DX & *DY models.

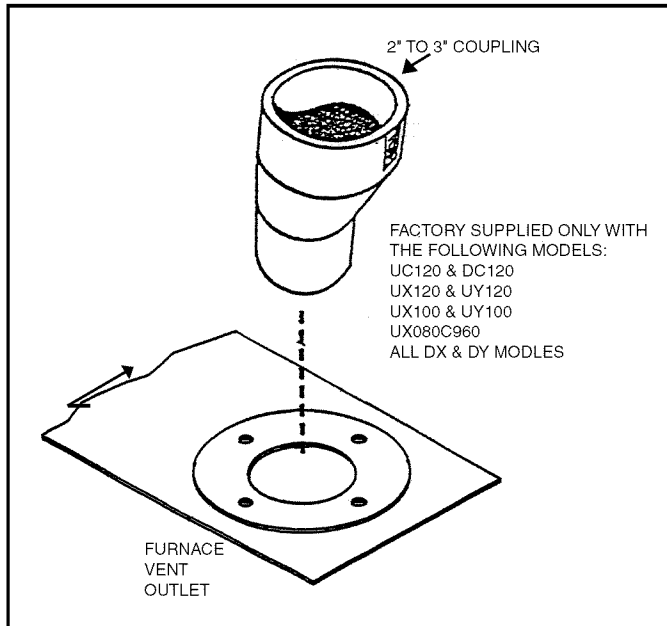
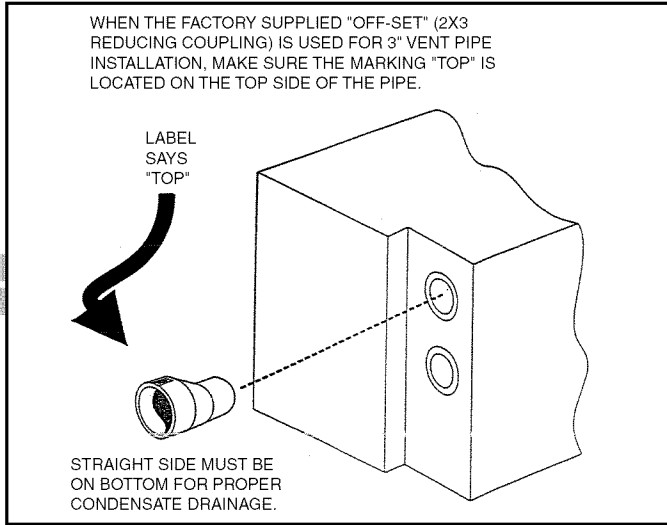

All pipe joints must be fastened and sealed to prevent escape of combustion products into the building.

NOTE:
Both venting methods shown in Figure 39 & 41 must also have the combustion air inlet installed - meeting dimension requirements of Figure 35.

CONDENSATE DRAIN INSTRUCTIONS

CAUTION
IT IS RECOMMENDED THAT A DRAIN PAN BE INSTALLED UNDER THE FURNACE TO PREVENT PROPERTY DAMAGE, PERSONAL INJURY OR DEATH FROM LEAKING CONDENSATE.

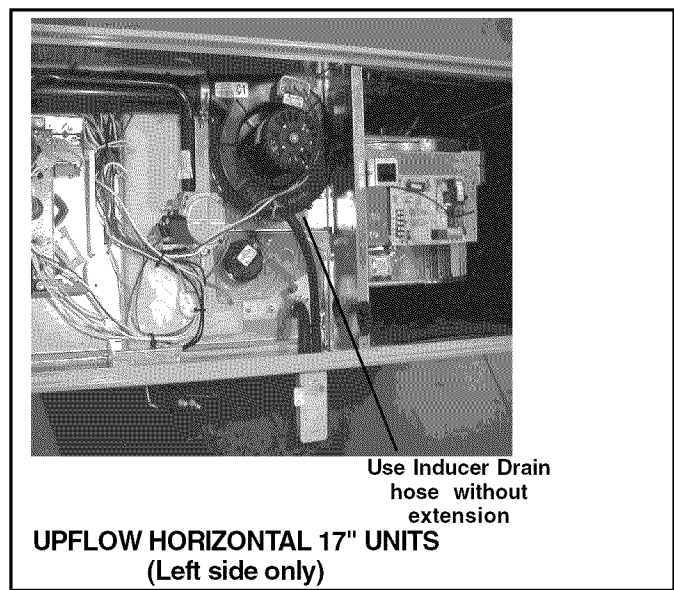
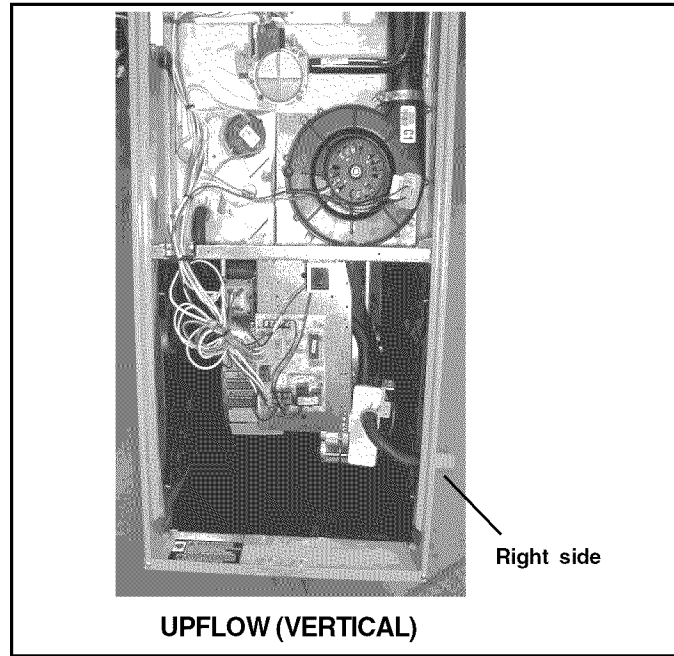

VERTICAL APPLICATIONS

Upflow furnace - The connection tubing for left and right side drainage is shipped in the blower compartment. Install the connection tubing from the trap to the side of the unit and trim all excess tubing to avoid kinks.

Downflow furnace - The furnace is shipped with the left side drainage setup. To change the right side drain, remove the drain lines from the trap, rotate the trap 180° so it exits to the right, reconnect the lines, and run a 1/2" CPVC pipe from the trap out through the right side knock-out. Use RTV silicone sealant to connect the CPVC pipe to the trap for ease of removing to clean the trap.

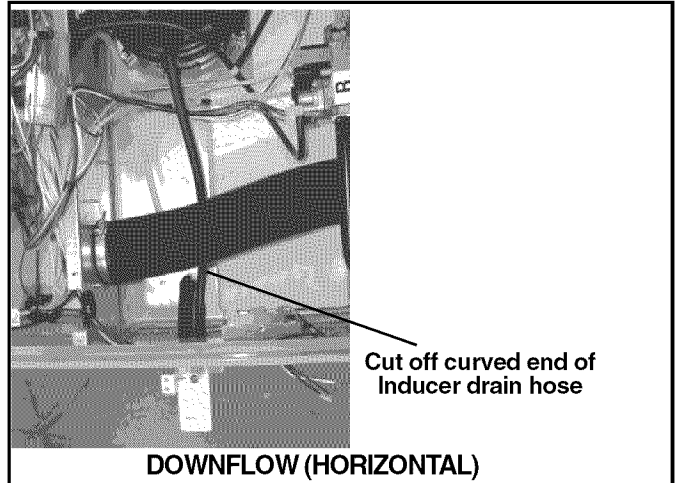
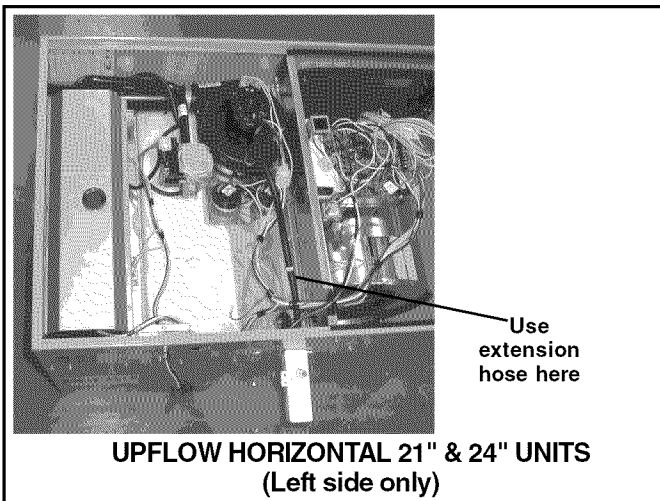
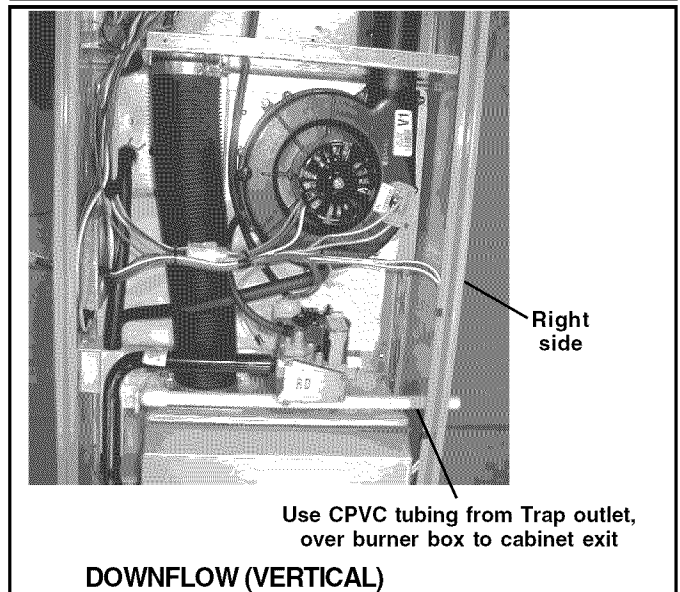
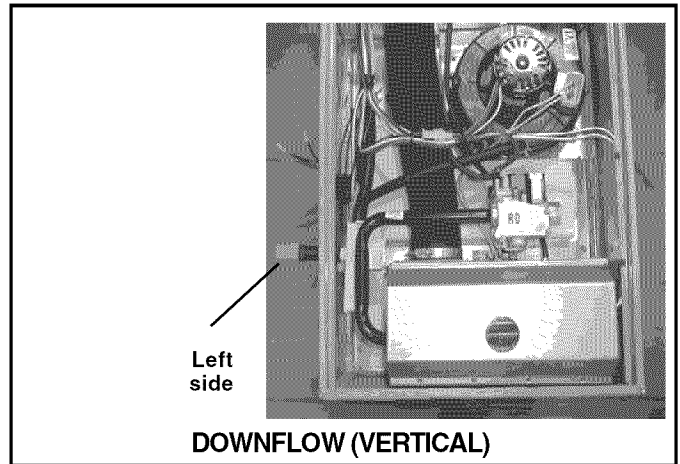
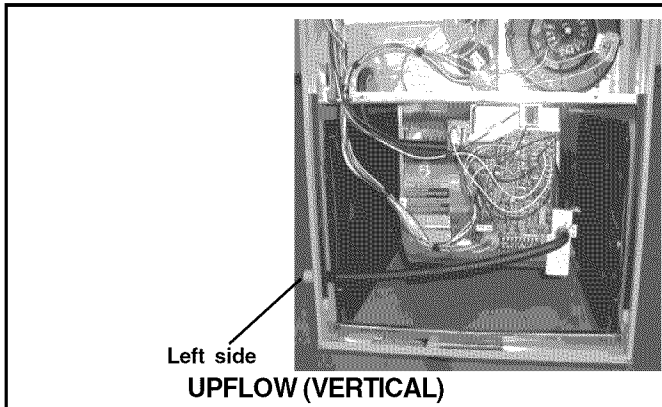

HORIZONTAL APPLICATIONS

Upflow and Downflow furnaces - All horizontal applications are left side only. It is always recommended that the auxiliary drain pan be installed under a horizontally installed evaporator and/or 90° gas furnace. Connect the auxiliary drain pan to a separate drain line (no trap is needed in this line).

The trap must be repositioned to the exterior of the cabinet. Remove the trap from its present location and reposition the trap outside of the unit, through the long circular hole, next to the secondary recuperated cell. Remove the larger drain line (from the secondary cell) and trim to fit between the secondary cell and the new trap location. On upflow units, plug the hole in the blower deck where the tube went through.

Remove the hose from the induced blower and reposition into the other drain tap of the inducer, which is lo-

cated 90° clockwise around the inducer. Move the cap from that drain tap to the unused drain tap. On upflow units, plug the hole in the blower deck where the tube went through. This tube on downflow units will need to be cut to fit between the inducer and the trap. On upflow units, this tube may need to be extended, using the tubing shipped with the furnace.

Installer's Guide

Connections must be made to an **OPEN/ VENTED DRAIN**. Outdoor draining of the furnace and coil condensate is permissible if allowed by local codes. Caution should be taken to prevent drains from freezing or causing slippery conditions that could lead to personal injury. Excessive draining of condensate may cause saturated ground conditions that may result in damage to plants.

NOTE:

Use 1/2" or larger PVC or CPVC pipe and fittings as required for drain connections (fittings, pipe and solvent cement not provided).

NOTE:

A corrosion resistant condensate pump must be used if a pump is required for a specific drain system.

IMPORTANT:

The condensate drain should be installed with provisions to prevent winter freeze-up of the condensate drain line. Frozen condensate will block drains, resulting in furnace shut-down. If the drain line cannot be installed in a conditioned space, then UL listed heat tape should be applied as required to prevent freezing (per manufacturer's instructions). The heat tape should be rated at 5 or 6 watts per foot at 120 volts. Self-regulating (preferred) or thermostatically controlled heat tape is required.

Evaporator and furnace condensate drain piping may be manifolded together as shown in Figure 45. A primary drain vent stack must be installed and terminated below the outlet of the secondary heat exchanger drain connection to prevent water from damaging furnace controls if the primary drain outlet plugs up. Where the furnace is installed above a finished ceiling, the primary drain vent stack must be installed such that overflow from the vent stack opening will flow into an auxiliary drain pan in order to prevent water damage to the finished ceiling below.

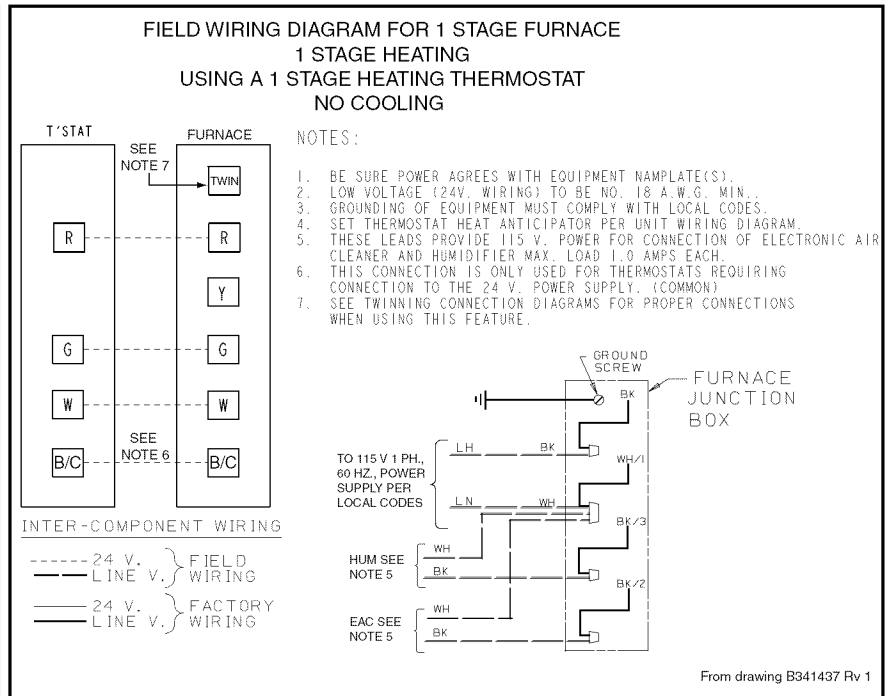
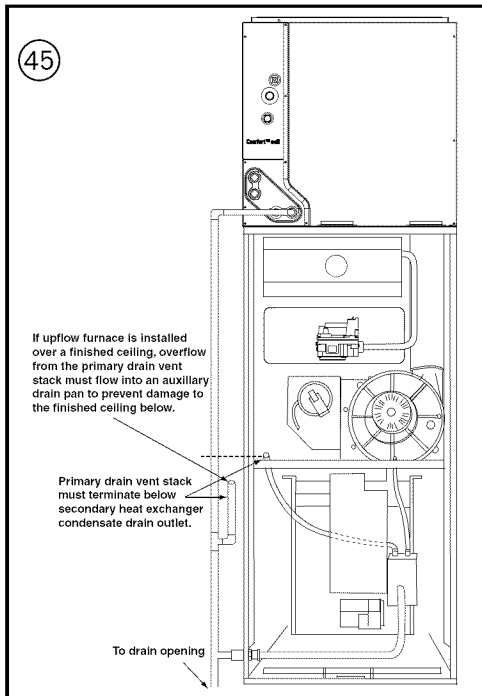

FIELD WIRING DIAGRAM FOR 1 STAGE FURNACE 1 STAGE HEATING, 1 STAGE COOLING USING A 1 STAGE HEATING, 1 STAGE COOLING THERMOSTAT (OUTDOOR SECTION WITHOUT TRANSFORMER)

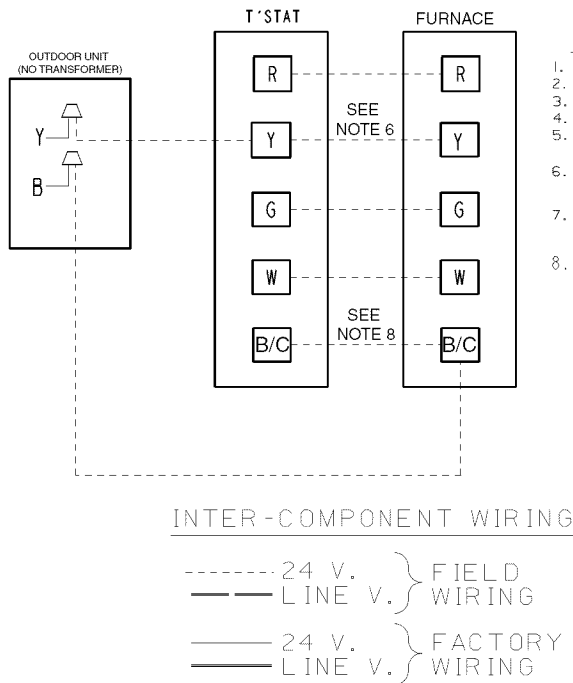

NOTES:

1. BE SURE POWER AGREES WITH EQUIPMENT NAMEPLATE(S)
2. LOW VOLTAGE(24 V. WIRING) TO BE NO. 18 A.W.G. MIN.
3. GROUNDING OF EQUIPMENT MUST COMPLY WITH LOCAL CODES.
4. SET THERMOSTAT HEAT ANTICIPATOR PER UNIT WIRING DIAGRAM.
5. THESE LEADS PROVIDE 115 V. POWER FOR CONNECTION OF ELECTRONIC AIR CLEANER AND HUMIDIFIER MAX. LOAD 1.0 AMPS EACH.
6. THE "Y" TERMINAL FROM THE THERMOSTAT MUST BE WIRED TO THE "Y" TERMINAL OF THE FURNACE CONTROL FOR PROPER BLOWER OPERATION DURING COOLING.
7. IGNITION CONTROL IS POLARITY SENSITIVE. HOT LEG OF 120 VOLT POWER SUPPLY MUST BE CONNECTED TO THE BLACK LINE POWER LEAD AS INDICATED ON THE WIRING DIAGRAM OR IGNITION LOCKOUT WILL OCCUR.
8. THIS CONNECTION IS ONLY USED FOR THERMOSTATS REQUIRING CONNECTION TO THE 24 V. POWER SUPPLY. (COMMON)

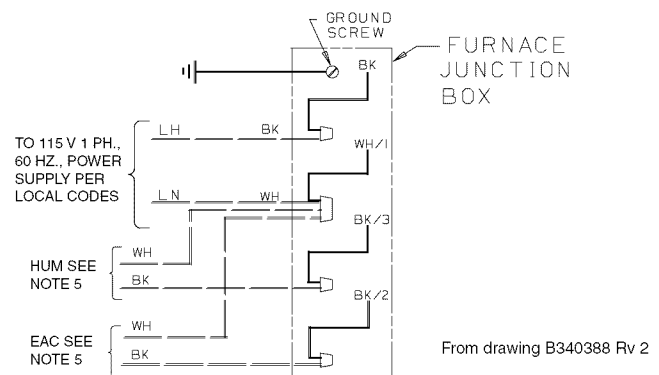

ELECTRICAL CONNECTIONS

Make wiring connections to the unit as indicated on enclosed wiring diagram. As with all gas appliances using electrical power, this furnace shall be connected into a permanently live electric circuit. It is recommended that furnace be provided with a separate "circuit protection device" in the electric circuit. The furnace must be electrically grounded in accordance with local codes or in the absence of local codes with the National Electrical Code, ANSI/NFPA 70 or CSA C22.1 Electrical Code, if an external electrical source is utilized.

The integrated furnace control is polarity sensitive. The hot leg of the 120V power supply must be connected to the black power lead as indicated on the wiring diagram. Provision for hooking up an electronic air cleaner and or humidifier is provided on the integrated control.

Refer to the SERVICE FACTS literature and unit wiring diagram attached to furnace diagram attached to furnace.

**TWINNING CONNECTION DIAGRAM
FOR TWINNING 1 STAGE FURNACES WITH
SINGLE WIRE TWINNING FEATURE
1 STAGE HEATING ONLY THERMOSTAT**

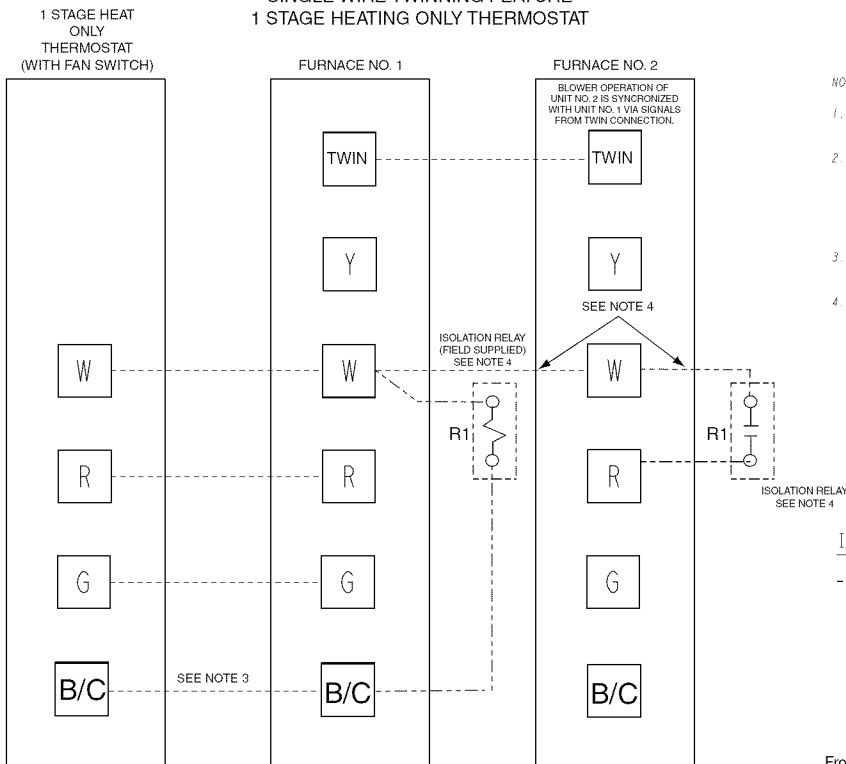

- NOTES:
1. BOTH FURNACES MUST BE POWERED FROM THE SAME 115V. LEG OF CIRCUIT PANEL.
 2. INSURE 24V. FURNACE TRANSFORMERS ARE IN PHASE PRIOR TO COMPLETING CONNECTIONS, CHECK VOLTAGE BETWEEN 'R' TERMINALS OF EACH FURNACE. IF VOLTAGE IS GREATER THAN 10V., REVERSE THE BL AN RD SECONDARY LEADS ON ONE OF THE FURNACE TRANSFORMERS.
 3. CONNECTION MAY BE REQUIRED FOR ELECTRONIC THERMOSTAT.
 4. IF CURRENT EXCEEDS THERMOSTAT CURRENT RATING, USE ISOLATION RELAYS ('R1') AS SHOWN. (DO NOT CONNECT W TO #1) ISOLATION RELAY NOT NEEDED IF THE THERMOSTAT CONTACTS ARE RATED AT 1.0A. OR ABOVE.

INTER-COMPONENT WIRING

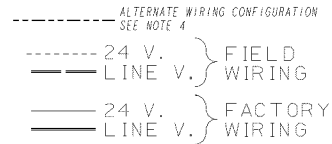

From Dwg. 21B341422 Rev. 3

**TWINNING CONNECTION DIAGRAM
FOR TWINNING 1 STAGE FURNACES WITH
SINGLE WIRE TWINNING FEATURE
1 STAGE HEAT / 1 STAGE COOL THERMOSTAT**

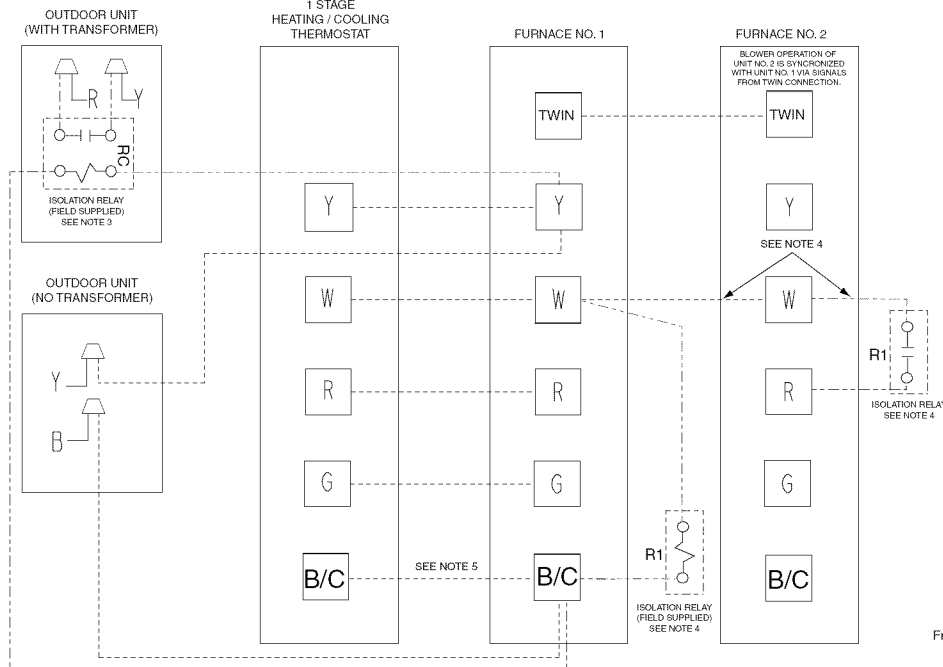

- NOTES:
1. BOTH FURNACES MUST BE POWERED FROM THE SAME 115V. LEG OF CIRCUIT PANEL.
 2. INSURE 24V. FURNACE TRANSFORMERS ARE IN PHASE PRIOR TO COMPLETING CONNECTIONS, CHECK VOLTAGE BETWEEN 'R' TERMINALS OF EACH FURNACE. IF VOLTAGE IS GREATER THAN 10V., REVERSE THE BL AN RD SECONDARY LEADS ON ONE OF THE FURNACE TRANSFORMERS.
 3. IF OUTDOOR UNIT HAS A 24V. TRANSFORMER, AN ISOLATION RELAY MUST BE INSTALLED. (FIELD SUPPLIED - USE PILOT DUTY RELAY ('RC'), SUCH AS RLY0975.) SEE ALT. CONNECTION.
 4. IF CURRENT EXCEEDS THERMOSTAT CURRENT RATING, USE ISOLATION RELAYS ('R1') AS SHOWN. (DO NOT CONNECT W TO #1) ISOLATION RELAY NOT NEEDED IF THE THERMOSTAT CONTACTS ARE RATED AT 1.0A. OR ABOVE.
 5. CONNECTION MAY BE REQUIRED FOR ELECTRONIC THERMOSTATS.

INTER-COMPONENT WIRING

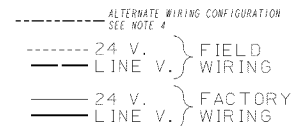

From Dwg. 21B341423 Rev. 2

TWINNING FURNACES

These furnaces may be twinned. Twinning requires that two furnaces with the same configuration, capacity, and airflow must be used. They shall have common returns with equal pressure drops or ducts with equivalent lengths and sizes. See Field Wiring Diagrams for proper hookup.

GAS PIPING

The upflow/ horizontal furnace is shipped standard for left side installation of gas piping. A knock-out is provided on the right side for an alternate gas piping arrangement. See Figure 46.

The installation of piping shall be in accordance with piping codes and the regulations of the local gas company. Pipe joint compound must be resistant to the chemical reaction with liquefied petroleum gases. Refer to piping Table 10, for delivery sizes. Connect gas supply to the unit, using a ground joint union and a manual shut-off valve as shown in Figures 46-48.

National codes require a condensation drip leg to be installed ahead of the controls as shown in Figures 46-48. The furnace and its individual shut-off valve must be disconnected from the gas supply piping system during any pressure testing of that system at test pressures in excess of 1/2 psig (3.5 kPa).

The furnace must be isolated from the gas supply piping by closing its individual manual shut-off valve during any pressure testing of the gas supply piping system at test pressures equal to or less than 1/2 psig (3.5 kPa).

NOTE:

Maximum pressure to the gas valve for natural gas is 13.8" W.C. Minimum pressure is 5.0" W.C. Maximum pressure to the gas valve for propane is 13.8" W.C. Minimum pressure is 11.0" W.C.

*All gas fittings must be checked for leaks using a soapy solution before lighting the furnace. **DO NOT CHECK WITH AN OPEN FLAME!***

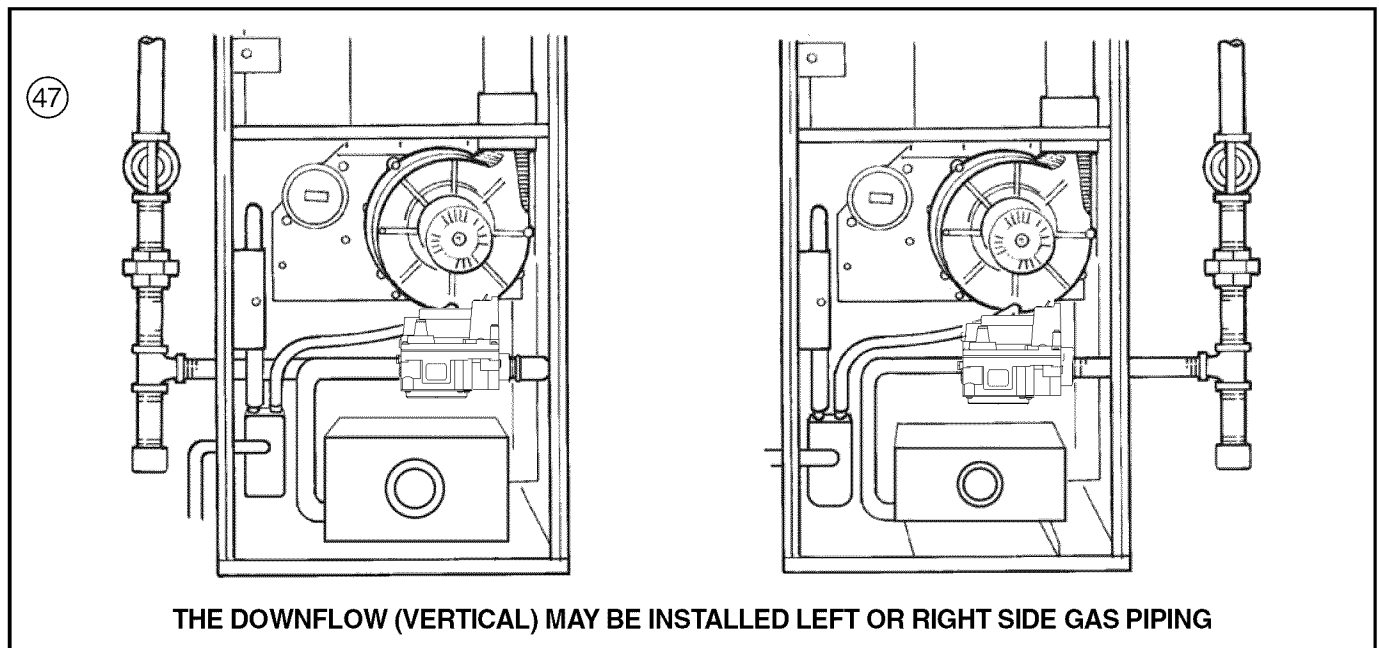
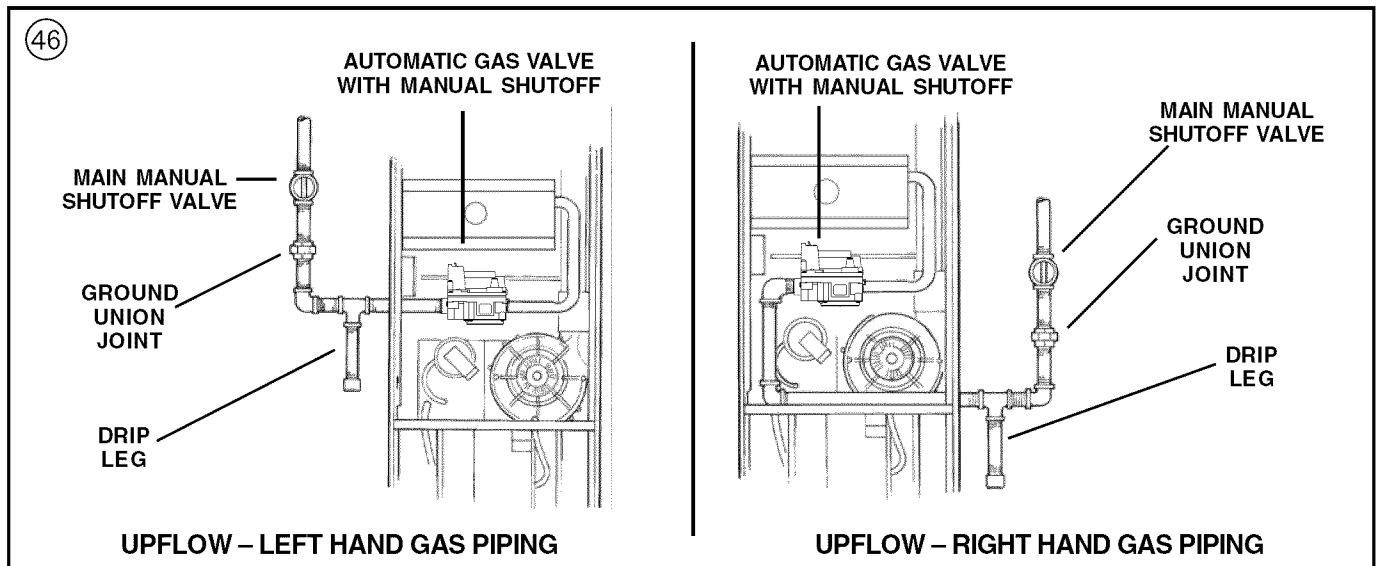

THE DOWNFLOW (VERTICAL) MAY BE INSTALLED LEFT OR RIGHT SIDE GAS PIPING

Installer's Guide

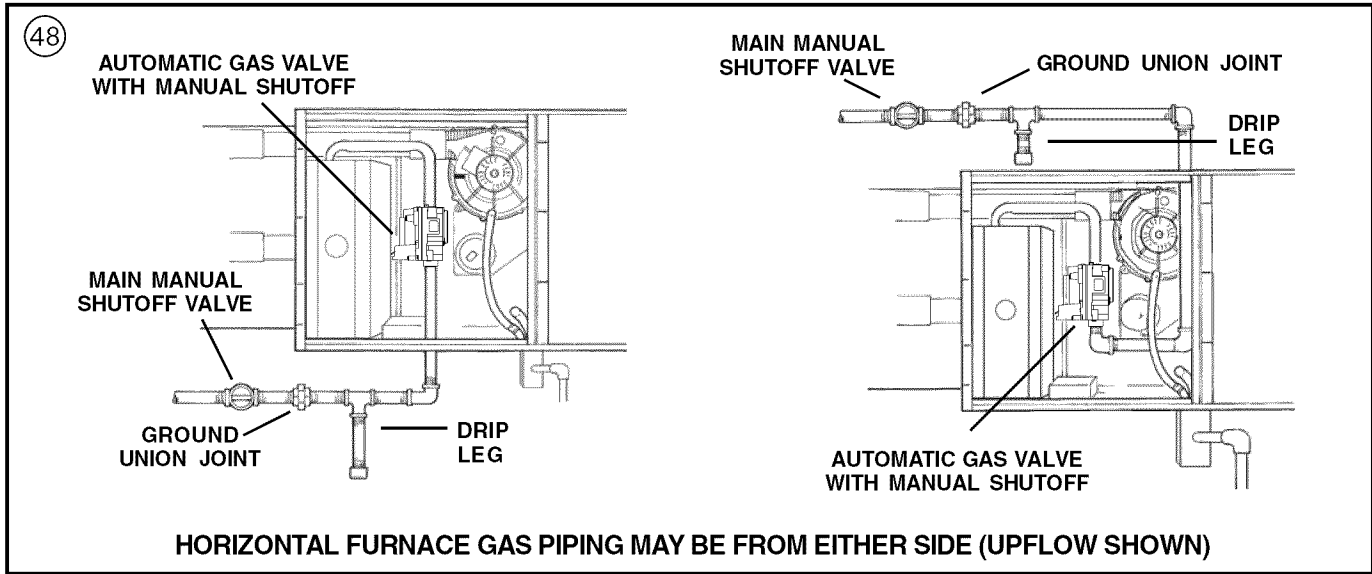

⚠ CAUTION
 Use a backup wrench on the gas valve when installing gas piping to prevent damage to the gas valve and manifold assembly.

TABLE 10

NATURAL GAS ONLY

TABLE OF CUBIC FEET PER HOUR OF GAS FOR VARIOUS PIPE SIZES AND LENGTHS							
PIPE SIZE	LENGTH OF PIPE						
	10	20	30	40	50	60	70
1/2	132	92	73	63	56	50	46
3/4	278	190	152	130	115	105	96
1	520	350	285	245	215	195	180
1-1/4	1050	730	590	520	440	400	370

This table is based on pressure drop of 0.3 inch W.C. and 0.6 SP.GR. gas

**TABLE 11
 ORIFICE SIZES**

INPUT RATING BTUH	NUMBER OF BURNERS	MAIN BURNER ORIFICE DRILL SIZE	
		NAT. GAS	LP GAS
40,000	2	45	56
60,000	3	45	56
80,000	4	45	56
100,000	5	45	56
120,000	6	45	56

COMBUSTION AND INPUT CHECK

1. Make sure all gas appliances are off except the furnace.
2. Clock the gas meter with the furnace operating (determine the dial rating of the meter) for one revolution.
3. Match the "Sec" column in the gas flow (in cfh) Table 13 with the time clocked.
4. Read the "Flow" column opposite the number of seconds clocked.

5. Use the following factors if necessary:
 For 1 Cu. Ft. Dial Gas Flow CFH = Chart Flow Reading ÷ 2
 For 1/2 Cu Ft. Dial Gas Flow CFH = Chart Flow Reading ÷ 4
 For 5 Cu. Ft. Dial Gas Flow CFH = 10X Chart Flow Reading ÷ 4
6. Multiply the final figure by the heating value of the gas obtained from the utility company and compare to the nameplate rating. This must not exceed the nameplate rating.
7. Changes can be made by adjusting the manifold pressure or changing orifices (orifice change may not always be required). To adjust the manifold pressure:
 - a. Turn off all electrical power to the system.
 - b. Attach a manifold pressure gauge to the outlet pressure tap marked "OUT PRESS TAP" on White-Rodgers gas valve model 36F or boss marked "OUT P" on White-Rodgers gas valve model 36G. (See Figure 51 for White-Rodgers gas valve model 36F and Figure 52 for White-Rodgers gas valve model 36G). For the gas valve model 36F, measurement requires removal of the plug and installation of a barbed fitting. Attach flexible tubing and a manometer to the barbed fitting. For the gas valve model 36G, do not remove the pressure tap test screw. Using a 3/32" hex wrench, loosen the pressure tap test screw one turn and install 5/16" flexible tubing and a manometer directly onto the outlet pressure boss.
 - c. Turn on system power and energize valve.
 - d. Remove the regulator adjustment screw cap on the gas valve for manifold pressure adjustment.
 - e. Turn the adjustment nut clockwise to increase the gas flow rate, and counterclockwise to decrease the gas flow rate using a 3/32" hex wrench.

- f. The final manifold pressure setting shall be as specified in Table 12 with an input of no more than nameplate rating and no less than 93% of the nameplate rating, unless the unit is derated for high altitude.
- g. Replace the regulator adjustment screw cap and tighten securely.
- h. Turn off all electrical power to the system.
- i. Remove the manometer and flexible tubing. Remove the barbed fitting and replace the plug or tighten the pressure test screw.
- j. Turn on electrical power to the system and energize valve.
- k. Using a leak detection solution or soap suds, check for leaks at plug or pressure boss screw.

⚠ CAUTION

Replace manifold pressure tap threaded plug and leak check after checking/ adjusting manifold gas pressure.

Table 11 lists the main burner orifices used with the furnace. If a change of orifices is required to correct the furnace input rating refer to Table 14.

TABLE 12

FINAL MANIFOLD PRESSURE SETTINGS	
FUEL	PRESSURE
NATURAL GAS	3.5" W.C.
LP GAS	11.0" W.C.

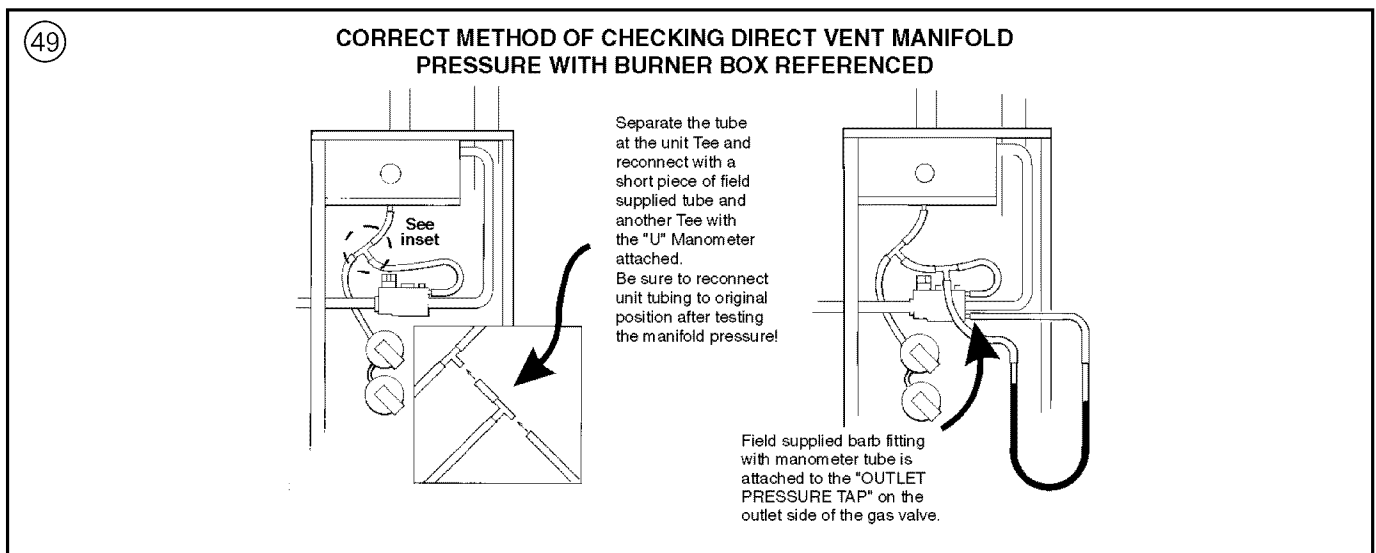

⚠ CAUTION

Replace and/ or tighten all plugs removed or loosened when adjusting gas pressure. Leak check the fittings before placing the furnace into regular service. Failure to follow this warning could result in fire, explosion, or property damage.

NOTE:

The manifold pressure must be referenced to the burner box. The burner box pressure tap equalizes the gas valve pressure regulator. Manifold pressure is checked by installing a tee (field supplied) in the tubing, between the tee coming from the burner box tube and the gas valve, in addition to the regular gas valve pressure tap on the outlet side of the gas valve. See Figure 49.

Installer's Guide

HIGH ALTITUDE DERATE

Input ratings (BTUH) of these furnaces are based on sea level operation and should not be changed at elevations up to 2,000 ft.

If the installation is 2,000 ft. or above, the furnace input rate (BTUH) shall be reduced 4% for each 1,000 ft. above sea level. The furnace input rate shall be checked by clocking the gas flow rate (CFH) and multiplying by the heating value obtained from the local utility supplier for the gas being delivered at the installed altitude. Input rate changes can be made by adjusting the manifold pressure (min 3.0 - max 3.7 in. W.C. - Natural Gas) or changing orifices (orifice change may not always be required). If the desired input rate can not be achieved with a change in manifold pressure, then the orifices must be changed. LP installations will require an orifice change.

Installation of this furnace at altitudes above 2,000 ft. (610m) shall be in accordance with the local codes, or in the absence of local codes, the *National Fuel Gas Code, ANSI Z223.1/ NFPA 54* or *National Standard of Canada, Natural Gas and Propane Installation Code, CSA 149.1*. Installation of this furnace at altitudes above 2,000 ft. (610m) shall be made in accordance with the listed high Altitude Conversion Kit available with this furnace.

IMPORTANT:

Re-install the propane orifices to the same depth as the orifices supplied with the equipment.

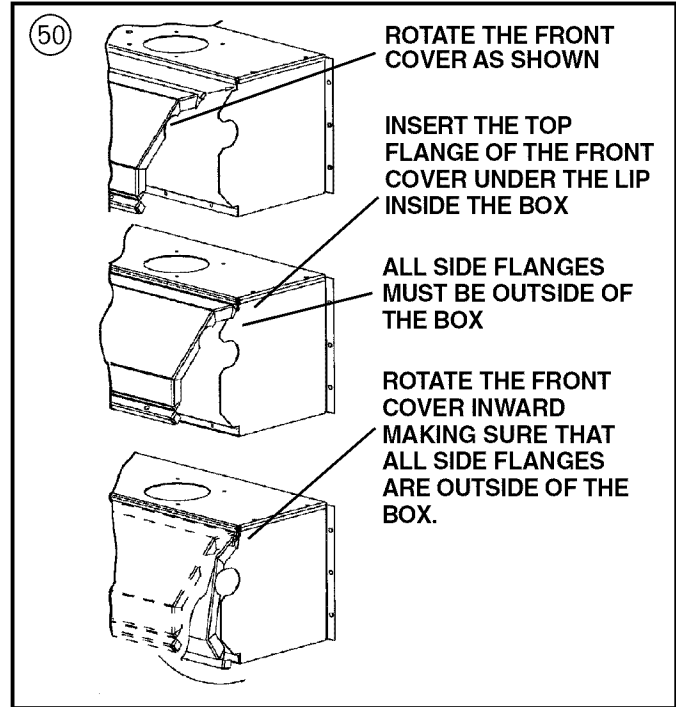

TABLE 13

GAS FLOW IN CUBIC FEET PER HOUR							
2 CUBIC FOOT DIAL							
SEC.	FLOW	SEC.	FLOW	SEC.	FLOW	SEC.	FLOW
8	900	29	248	50	144	82	88
9	800	30	240	51	141	84	86
10	720	31	232	52	138	86	84
11	655	32	225	53	136	88	82
12	600	33	218	54	133	90	80
13	555	34	212	55	131	92	78
14	514	35	206	56	129	94	76
15	480	36	200	57	126	96	75
16	450	37	195	58	124	98	73
17	424	38	189	59	122	100	72
18	400	39	185	60	120	104	69
19	379	40	180	62	116	108	67
20	360	41	176	64	112	112	64
21	343	42	172	66	109	116	62
22	327	43	167	68	106	120	60
23	313	44	164	70	103	124	58
24	300	45	160	72	100	128	56
25	288	46	157	74	97	132	54
26	277	47	153	76	95	136	53
27	267	48	150	78	92	140	51
28	257	49	147	80	90	144	50

See Table 15 for help in selecting orifices if orifice change is required. Furnace input rate and temperature rise should be checked again after changing orifices to confirm the proper rate for the altitude.

Installations above 4,000 feet may require a pressure switch change. If required, use the BAYHALT*** Kit (High Altitude Accessory Kit) listed in PRODUCT DATA.

TABLE 14
PART NUMBERS FOR REPLACEMENT ORIFICES

DRILL SIZE	PART NUMBER	DRILL SIZE	PART NUMBER
44	ORF00501	54	ORF00555
45	ORF00644	55	ORF00693
46	ORF00909	56	ORF00907
47	ORF00910	57	ORF00908
48	ORF01099	58	ORF01338
49	ORF00503	59	ORF01339
50	ORF00493		

REINSTALLATION OF THE BURNER BOX COVER

Figure 50 shows the correct way to reinstall the burner box cover if adjustment or replacement of the flame sensor, hot surface igniter, or main burner orifices have required removal of the cover.

TABLE 15

Orifice Twist Drill Size If Installed At Sea Level	ALTITUDE ABOVE SEA LEVEL and Orifice Required At Other Elevations									
	2000	3000	4000	5000	6000	7000	8000	9000	10000	
	42	42	43	43	43	44	44	45	46	47
43	44	44	44	45	45	46	47	47	48	
44	45	45	45	46	47	47	48	48	50	
45	46	47	47	47	48	48	49	49	50	
46	47	47	47	48	48	49	49	50	51	
47	48	48	49	49	49	50	50	51	52	
54	54	55	55	55	55	55	56	56	56	
55	55	55	55	56	56	56	56	56	57	
56	56	56	57	57	57	58	59	59	60	
57	58	59	59	60	60	61	62	63	63	
58	59	60	60	61	62	62	63	63	64	

From National Fuel Gas Code - Table F-4

⚠ WARNING

CARBON MONOXIDE POISONING HAZARD

Failure to follow the installation instructions for the venting system being placed into operation could result in carbon monoxide poisoning or death.

START UP AND ADJUSTMENT

PRELIMINARY INSPECTIONS

With gas and electrical power "OFF"

1. Duct connections are properly sealed
2. Filters are in place
3. Venting is properly assembled
4. Blower door is in place

Flip the switch on main gas valve within the unit to the "OFF" position. Turn the external gas valve to "ON". Purge the air from the gas lines. After purging, Check all gas connections for leaks with a soapy solution —

DO NOT CHECK WITH AN OPEN FLAME. Allow 5 minutes for any gas that might have escaped to dissipate. LP Gas being heavier than air may require forced ventilation. Flip the switch on the gas valve in the unit to the "ON" position.

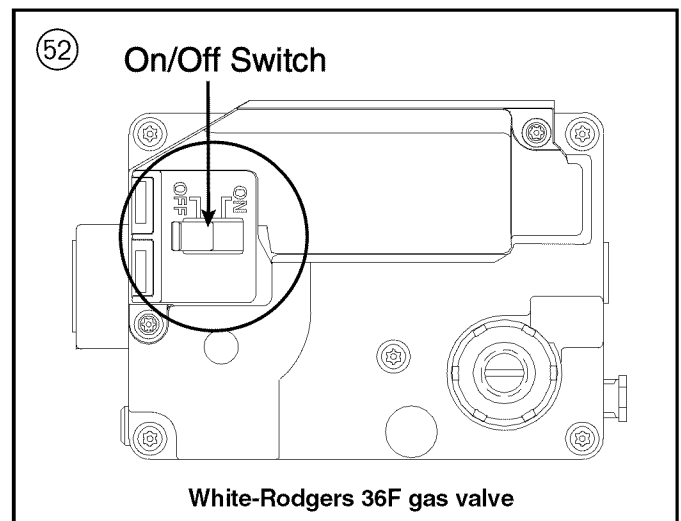
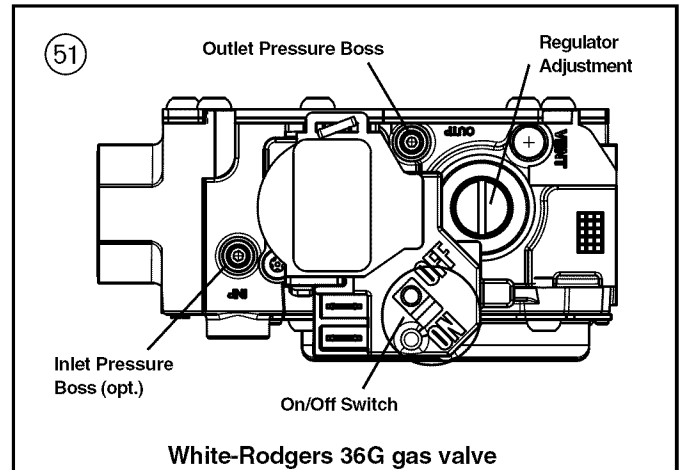

LIGHTING INSTRUCTIONS

⚠ WARNING

DO NOT attempt to manually light the burner. Failure to follow this warning could result in property damage, personal injury or death.

Lighting instructions appear on each unit. Each installation must be checked out at the time of initial start up to insure proper operation of all components. Check out should include putting the unit through one complete cycle as outlined below.

Turn on the main electrical supply and set the thermostat above the indicated temperature. The ignitor will automatically heat, then the gas valve is energized to permit the flow of gas to the burners. After ignition and flame is established, the flame control module monitors the flame and supplies power to the gas valve until the thermostat is satisfied.

Installer's Guide

To shut off.

For complete shut-down: Flip the switch on the main gas valve to the "OFF" position, (See Figure 51 & 52). Disconnect the electrical supply to the unit.

⚠ CAUTION

If this is done during the cold weather months, provisions must be taken to prevent freeze-up of all water pipes and water receptacles.

Failure to follow this warning could result in property damage.

Whenever your house is to be vacant, arrange to have someone inspect your house for proper temperature. This is very important during freezing weather. If for any reason your furnace should fail to operate damage could result, such as frozen water pipes.

SEQUENCE OF OPERATION

Thermostat call for heat

R and W thermostat contacts close signaling the control module to run its self-check routine. After the control module has verified that the pressure switch contacts are open and the limit switch(es) contacts are closed, the draft blower will be energized.

As the induced draft blower comes up to speed, the pressure switch contacts will close and the ignitor warm up period will begin. The ignitor will heat for approximately 20 seconds, then the gas valve is energized to permit gas flow to the burners. The flame sensor confirms that ignition has been achieved.

After the flame sensor confirms within a 4 second trial period that ignition has been achieved, the delay to fan ON period begins timing. After approximately 45 seconds the indoor blower motor will be energized and continue to run during the heating cycle.

When the thermostat is satisfied, R and W thermostat contacts open, the gas valve will close, the flames will extinguish, and the induced draft blower will be de-energized. The indoor blower motor will continue to run for the fan off period (Field selectable at 60, 100, 140 or 180 seconds), then be de-energized by the control module.

CONTROL AND SAFETY SWITCH ADJUSTMENTS

LIMIT SWITCH CHECK OUT

The limit switch is a safety device designed to close the gas valve should the furnace become overheated. Since proper operation of this switch is important to the safety of the unit, **it must be checked out on initial start up by the installer.**

To check for proper operation of the limit switches, set the thermostat to a temperature higher than the indicated temperature to bring on the gas valve. Restrict the airflow by blocking the return air (disconnecting the indoor blower may trip the inducer limit). When the

furnace reaches the maximum outlet temperature as shown on the rating plate, the burners must shut off. If they do not shut off after a reasonable time and overheating is evident, a faulty limit switch is probable and the limit switch must be replaced. After checking the operation of the limit control, be sure to remove the paper or cardboard from the return air inlet. Refer to Service Facts for additional instructions.

NOTE TO INSTALLER

Review the following warnings with the owner. Review contents of USER'S INFORMATION MANUAL with the owner.

AIRFLOW ADJUSTMENT

Check inlet and outlet air temperatures to make sure they are within the ranges specified on the furnace rating nameplate. If the airflow needs to be increased or decreased, see the wiring diagram for information on changing the speed of the blower motor.

⚠ WARNING

Disconnect power to the unit before removing the blower door.

Failure to follow this warning could result in property damage, personal injury or death.

This unit is equipped with a blower door switch which cuts power to the blower and gas valve causing shut-down when the door is removed. Operation with the door removed or ajar can permit the escape of dangerous fumes. All panels must be securely closed at all times for safe operation of the furnace.

INDOOR BLOWER TIMING

Heating: The integrated furnace control module controls the indoor blower. The blower start is fixed at 45 seconds after ignition. The FAN-OFF period is field selectable by dip switches at 60, 100, 140, or 180 seconds. The factory setting is 100 seconds (See wiring diagram).

Cooling: The fan delay off period is factory set at 0 seconds. The option for 80 second delay off is field selectable (See wiring diagram).

ROOM AIR THERMOSTAT

HEAT ANTICIPATOR ADJUSTMENT

Set the thermostat heat anticipator according to the current flow measured, or the settings found in the notes on the furnace wiring diagram (found in the SERVICE FACTS or inside the furnace casing).

INSTRUCTIONS TO THE OWNERS

In the event that electrical, fuel, or mechanical failures occur, the owner should immediately turn the gas supply off at the manual gas valve, located in the burner compartment. Also turn off electrical power to the furnace and contact the service agency designated by your dealer.

BURNER BOX TEMPERATURE LIMIT DEVICE

All models are equipped with a manual reset temperature limit located on the burner box. In case of excessive temperature, the limit will open and cause the circuit to open which shuts off all flow of gas.

ABNORMAL CONDITIONS

1. EXCESSIVE COMBUSTION PRESSURE (WIND IN EXCESS OF 40 M.P.H.) VENT OR FLUE BLOCKAGE

If pressure against induced draft blower outlet becomes excessive, the pressure switch will open and shut off the gas valve until acceptable combustion pressure is again available.

2. LOSS OF FLAME

If loss of flame occurs during a heating cycle, or flame is not present at the sensor, the flame control module will close the gas valve. The flame control module will then recycle the ignition sequence, then if ignition is not achieved, it will shut off the gas valve and lock out the system.

3. POWER FAILURE

If there is a power failure during a heating cycle, the system will restart the ignition sequence automatically when power is restored if the thermostat still calls for heat.

4. GAS SUPPLY FAILURE

If loss of flame occurs during a heating cycle, the system integrated control module will recycle the ignition sequence, then if ignition is not achieved, the integrated control module will shut off the gas valve and lock out the system.

5. INDUCED DRAFT BLOWER FAILURE

If pressure is not sensed by the pressure switch, the contacts will remain open and not allow the gas valve to open, therefore the unit will not start. If failure occurs during a running cycle, the pressure switch contacts will open and the gas valve will close to shut the unit down.

6. CONDENSATE DRAIN BLOCKAGE

If the condensate drain is blocked, either by debris, improper draining, or by freezing condensate, the pressure switch will sense the accumulation of condensate in the furnace drain pan. The pressure switch contacts will open and remain open, not allowing unit operation. The unit will not operate until the condensate drain has been cleared, and the condensate flows freely.

7. RESET AFTER LOCKOUT

When the integrated control module has shut the system down and gone into lockout, the system must be manually reset before the unit will restart. To reset, turn the system power off, then on, then off and then on again within 30 seconds. This may be done at the unit's power source or at the thermostat. *The system will not reset unless the procedure off-on-off-on is completed within 30 seconds.*

8. RESET AFTER BURNER BOX LIMIT SHUT-DOWN

If the furnace shuts down, one thing that can be checked is the burner box temperature limit switch. It is located on the bottom of the burner box. The vent and combustion air inlet terminations should be checked for blockage. If blockage exists, clear the problem and then the reset button may be depressed. **If there is no blockage of the terminations, the limit switch must be reset by a qualified servicer.**

Carbon monoxide, fire or smoke can cause serious bodily injury, death, and/or property damage.

A variety of potential sources of carbon monoxide can be found in a building or dwelling such as gas-fired clothes dryers, gas cooking stoves, water heaters, furnaces and fireplaces. The U.S. Consumer Product Safety Commission recommends that users of gas-burning appliances install carbon monoxide detectors as well as fire and smoke detectors per the manufacturers installation instructions to help alert dwelling occupants of the presence of fire, smoke or unsafe levels of carbon monoxide. These devices should be listed by Underwriters Laboratories, Inc. *Standards for Single and Multiple Station Carbon Monoxide Alarms, UL 2034* or CSA International Standard, *Residential Carbon Monoxide Alarming Devices, CSA 6.19*

NOTE:

The manufacturer of your furnace does not test any detectors and makes no representations regarding any brand or type of detector.

Installer's Guide

The following warning complies with State of California law, Proposition 65.

⚠️ WARNING: This product contains fiberglass wool insulation! Fiberglass dust and ceramic fibers are believed by the State of California to cause cancer through inhalation. Glasswool fibers may also cause respiratory, skin, or eye irritation.

PRECAUTIONARY MEASURES:

- Avoid breathing fiberglass dust.
- Use a NIOSH approved dust/mist respirator.
- Avoid contact with the skin or eyes. Wear long-sleeved, loose-fitting clothing, gloves, and eye protection.
- Wash clothes separately from other clothing; rinse washer thoroughly.
- Operations such as sawing, blowing, tear-out, and spraying may generate fiber concentrations requiring additional respiratory protection. Use the appropriate NIOSH approved respirator in these situations.

FIRST AID MEASURES:

Eye Contact - Flush eyes with water to remove dust. If symptoms persist, seek medical attention.

Skin Contact - Wash affected areas gently with soap and warm water after handling.

INTEGRATED FURNACE CONTROL ERROR FLASH CODES	
Flashing Slow ---	Normal - No call for Heat
Flashing Fast ---	Normal - Call for Heat
Continuous ON ---	Replace IFC
Continuous OFF ---	Check Power
2 Flashes ---	System Lockout (Retries or Recycles exceeded)
3 Flashes ---	Draft Pressure Error - Possible problems: a) Venting problem b) Pressure switch problem c) Inducer problem
4 Flashes ---	Open Temperature Limit Circuit
5 Flashes ---	Flame sensed when no flame should be present
6 Flashes ---	115 volt AC power reversed, poor grounding or system voltage too low
7 Flashes ---	Gas valve circuit error
8 Flashes ---	Low flame sense signal
9 Flashes ---	Check Ignitor Circuit and Line "N" to 24VAC "Common" voltage (≤ 2 volts) [possible grounding problem]



Trane
6200 Troup Highway
Tyler, TX 75707

03/08

For more information contact
your local dealer (distributor)

Since the manufacturer has a policy of continuous product and product data improvement, it reserves the
right to change design and specifications without notice.