

Installer's Guide

Condensing Units 2TTB0 & 2TTB2

ALL phases of this installation must comply with NATIONAL, STATE AND LOCAL CODES

IMPORTANT — This Document is **customer property** and is to remain with this unit. Please return to service information pack upon completion of work.

These instructions do not cover all variations in systems nor provide for every possible contingency to be met in connection with installation. All phases of this installation must comply with NATIONAL, STATE AND LOCAL CODES. Should further information be desired or should particular problems arise which are not covered sufficiently for the purchaser's purposes, the matter should be referred to your installing dealer or local distributor.

A. GENERAL

The following instructions cover 2TTB0 & 2TTB2; Condensing Units.

NOTICE:

These outdoor units may be used with indoor units equipped with Thermostatic Expansion Valve or Accutron™ Flow Control Check Valve (F.C.C.V.) assembly for refrigerant flow control only.

Check for transportation damage after unit is uncrated. Report promptly, to the carrier, any damage found to the unit.

To determine the electrical power requirements of the unit, refer to the nameplate of the unit. The electrical power available must agree with that listed on the nameplate.

B. LOCATION & PREPARATION OF THE UNIT

1. When removing unit from the pallet, notice the tabs on the basepan. Remove tabs by cutting with a sharp tool as shown in Figure 2 (see page 2).
2. The unit should be set on a level support pad at least as large as the unit base pan, such as a concrete slab. If this is not the application used please refer to application bulletin "Trane APB2001-02".
3. The support pad must NOT be in direct contact with any structure. Unit must be positioned a minimum of 12" from any wall or surrounding shrubbery to insure adequate airflow. Clearance must be provided in front of control box (access panels) & any other side requiring service access to meet National Electrical Code. Also, the unit location must be far enough away from any structure to prevent excess roof run-off water from pouring directly on the unit. Do not locate unit(s) close to bedroom(s).
4. The top discharge area must be unrestricted for at least five (5) feet above the unit.

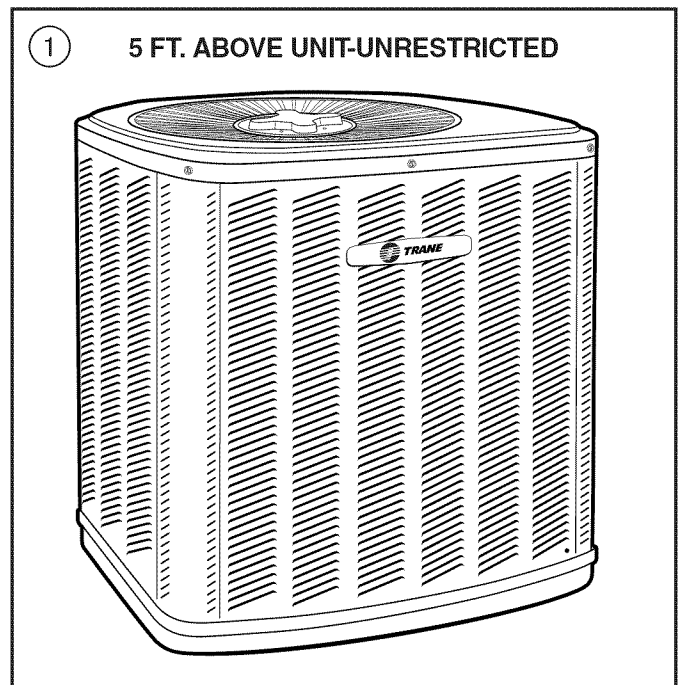

5. When the outdoor unit is mounted on a roof, be sure the roof will support the unit's weight. Properly selected isolation is recommended to prevent sound or vibration transmission to the building structure.
6. The maximum length of refrigerant lines from outdoor to indoor unit should NOT exceed sixty (60) feet.
7. If outdoor unit is mounted above the air handler, maximum lift should not exceed sixty (60) feet (suction line). If air handler is mounted above condensing unit, maximum lift should not exceed sixty (60) feet (liquid line).

NOTE:

Refer to "Refrigerant Piping Software" Pub. No. 32-3312-02.

8. Locate and install indoor coil or air handler in accordance with instruction included with that unit.

Installer's Guide



C. ACCUTRON™ FLOW CONTROL VALVE

If the indoor unit System Refrigerant Flow control is an Accutron™ orifice and check valve assembly, an orifice size change may be necessary. See Figure 3.

The outdoor model determines the required orifice size. Check the listed orifice size on nameplate of the selected outdoor model. If the indoor unit is factory shipped with a different orifice size, the orifice must be changed to obtain system rated performance.

IMPORTANT:

The outdoor unit is shipped with the proper size orifice and a stick-on orifice size label in an envelope attached to the outdoor unit. Outdoor unit nameplate will have correct orifice size specified as BAYFCCV--A for rated performance.

D. INSTALLING REFRIGERANT LINES

⚠ CAUTION

If using existing refrigerant lines make certain that all joints are brazed, not soldered.

Condensing units have provisions for braze connections.

Pressure taps are provided on the service valves of outdoor unit for compressor suction and liquid pressures.

The indoor end of the recommended refrigerant line sets may be straight or with a 90 degree bend, depending upon situation requirements. This should be thoroughly checked out before ordering refrigerant line sets.

The gas line must always be insulated.

⚠ CAUTION

In scroll compressor applications, dome temperatures may be hot. Do not touch top of compressor, may cause minor to severe burning.

The units are factory charged with the system charge required when using fifteen (15) feet of connecting line. Unit nameplate charge is the same.

Final refrigerant charge adjustment is necessary. Use the Charging Charts in the outdoor unit Service Facts.

1. Determine the most practical way to run the lines.
2. Consider types of bends to be made and space limitations.

NOTE:

Large diameter tubing will be very difficult to rebend once it has been shaped.

3. Determine the best starting point for routing the refrigerant tubing- **INSIDE OR OUTSIDE THE STRUCTURE.**

4. Provide a pull-thru hole of sufficient size to allow both liquid and gas lines.
5. Be sure the tubing is of sufficient length.
6. Uncoil the tubing --- do not kink or dent.
7. Route the tubing making all required bends and properly secure the tubing before making connections.
8. To prevent a noise within the building structure due to vibration transmission from the refrigerant lines, the following precautions should be taken:
 - a. When the refrigerant lines have to be fastened to floor joists or other framing in a structure, use isolation type hangers.
 - b. Isolation hangers should also be used when refrigerant lines are run in stud spaces or enclosed ceilings.
 - c. Where the refrigerant lines run through a wall or sill, they should be insulated and isolated.
 - d. Isolate the lines from all ductwork.

E. SERVICE VALVE OPERATION

BRASS LIQUID AND GAS LINE SERVICE VALVES

The Brass Liquid and Gas Line Service Valves are factory shipped in the seated position to hold factory charge. The pressure tap service port (when depressed) opens only to the field brazing side of the valve when the valve is in the seated position. The liquid line valve is **not** a back seating valve (see **WARNING** below).

⚠ WARNING

Extreme caution should be exercised when opening the Liquid Line Service Valve. Turn valve stem counterclockwise only until the stem contacts the rolled edge. (See Figure 4) No torque is required.

BRASS GAS LINE BALL SERVICE VALVE

The Brass Gas Line Ball Service Valve is shipped in the closed position to hold the factory refrigerant charge. The pressure tap service port (when depressed) opens only to the field brazing side when the valve is in the closed position. The Gas Line Ball Service Valve is full open with a 1/4 turn. See Figure 5.

BRAZING REFRIGERANT LINES

1. Remove lower access cover to access service valves.
2. Before brazing, remove plugs from external copper stub tubes. Clean internal and external surfaces of stub tubes prior to brazing.

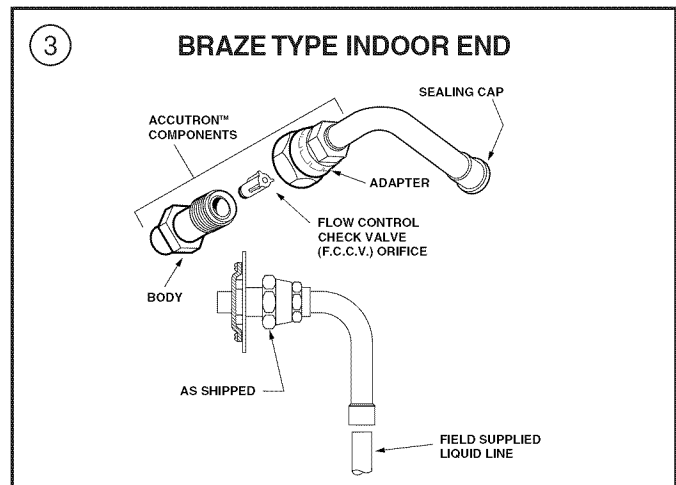

4

LIQUID LINE SERVICE VALVE

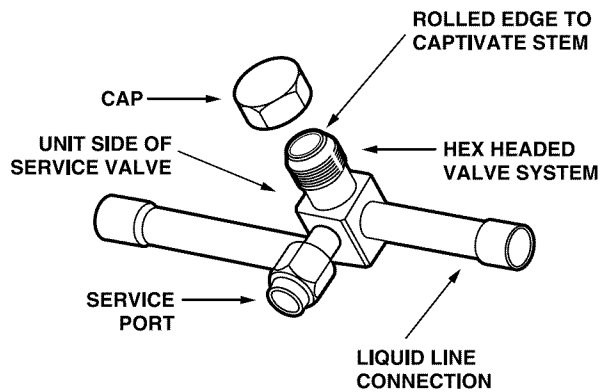

GAS LINE SERVICE VALVE

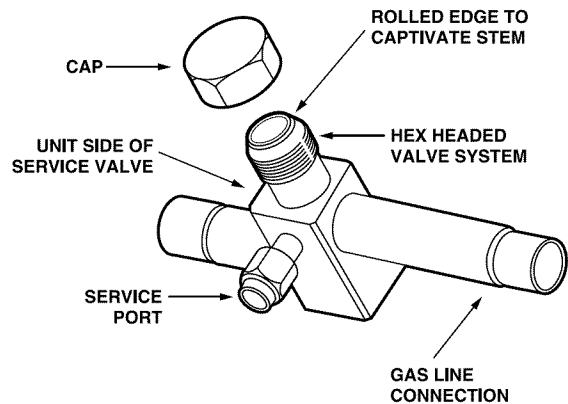

- Cut and fit tubing, minimizing the use of sharp 90° bends.
- Insulate the entire gas line and its fittings.
- Do **NOT** allow uninsulated liquid line to come in direct contact with bare gas line.
- Precautions should be taken to avoid heat damage to the pressure tap valve core during brazing. It is recommended that the pressure tap port valve core be removed and a wet rag wrapped around the valve body.**

NOTICE:

Use care to make sure that no moisture enters pressure tap port, while wet rag is being used.

NOTICE:

Precautions should be taken to avoid heat damage to basepan during brazing. It is recommended to keep the flame directly off of the basepan.

- Use a Dry Nitrogen Purge and Brazing Alloy without flux when brazing the field line to the copper factory connection. Flow dry nitrogen into either valve pressure tap port, thru the tubing and out the other port while brazing.
- Braze using accepted good brazing techniques.

LEAK CHECK

IMPORTANT:

Replace pressure tap port valve core before attaching hoses for evacuation.

After the brazing operation of refrigerant lines to both the outdoor and indoor unit is completed, the field brazed connections must be checked for leaks. Pressurize through the service valve ports, the indoor unit and field refrigerant lines with dry nitrogen to 350-400 psi. Use soap bubbles or other leak-checking methods to see that all field joints are leak-free! If not, **release pressure**; then repair!

SYSTEM EVACUATION

NOTE:

Since the outdoor unit has a refrigerant charge, the gas and liquid line valves must remain closed.

- Upon completion of leak check, evacuate the refrigerant lines and indoor coil before opening the gas and liquid line valves.
- Attach appropriate hoses from manifold gauge to gas and liquid line pressure taps.

NOTE:

Unnecessary switching of hoses can be avoided and complete evacuation of all lines leading to sealed system can be accomplished with manifold center hose and connecting branch hose to a cylinder of HCFC-22 and vacuum pump.

- Attach center hose of manifold gauges to vacuum pump.
- Evacuate until the micron gauge reads no higher than 350 microns.
- Close off valve to vacuum pump and observe the micron gauge. If gauge pressure rises above 500 microns in one (1) minute, then evacuation is incomplete or system has a leak.
- If vacuum gauge does not rise above 500 microns in one (1) minute, the evacuation should be complete.
- With vacuum pump and micron gauge blanked off, open valve on HCFC-22 cylinder and charge refrigerant lines and indoor coil with vapor to tank pressure of HCFC-22 supply.

NOTE:

DO NOT VENT REFRIGERANT INTO THE ATMOSPHERE.

- Close valve on HCFC-22 supply cylinder. Close valves on manifold gauge set and remove refrigerant charging hoses from liquid and gas pressure tap ports.

5

GAS LINE BALL SERVICE VALVE

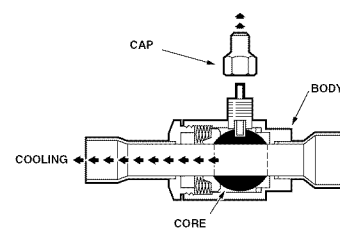
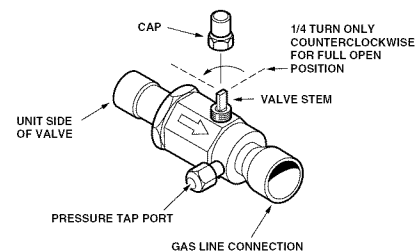

Installer's Guide

NOTE:

A 3/16" Allen wrench is required to open liquid line service valve. A 1/4" Open End or Adjustable wrench is required to open gas line valve. A 3/4" Open End wrench is required to take off the valve stem cap.

- The liquid line shut-off valve can now be opened. Remove shut-off valve cap. Fully insert hex wrench into the stem and backout counterclockwise until valve stem just touches rolled edge (approximately five [5] turns) observing **WARNING** statement on page 2. See Figure 4.
- Replace liquid service pressure tap port cap and valve stem cap. These caps **MUST BE REPLACED** to prevent leaks. Replace valve stem cap and pressure tap cap finger tight, then tighten an additional 1/6 turn.
- The gas valve can now be opened. For a ball type gas valve, open the gas valve by removing the shut-off valve cap and turning the valve stem 1/4 turn counterclockwise, using 1/4" Open End or Adjustable wrench. See Figure 5. For brass gas line service valve opening, follow 9 and 10 above. See Figure 4.
- The gas valve is now open for refrigerant flow. Replace valve stem cap to prevent leaks. Again, these caps **MUST BE REPLACED** to prevent leaks. Replace valve stem cap and pressure tap cap finger tight, then tighten an additional 1/6 turn. See Figure 5.

If refrigerant lines are longer than 15 feet and/or a different size than recommended, it will be necessary to adjust system refrigerant charge upon completion of installation. See unit Service Facts.

F. ELECTRICAL CONNECTIONS

⚠ WARNING

When installing or servicing this equipment, ALWAYS exercise basic safety precautions to avoid the possibility of electric shock.

- Power wiring and grounding of equipment must comply with local codes.
- Power supply must agree with equipment nameplate.
- Install a separate disconnect switch at the outdoor unit.
- Ground the outdoor unit per local code requirements.
- Provide flexible electrical conduit whenever vibration transmission may create a noise problem within the structure.
- The use of color coded low voltage wire is recommended to simplify connections between the outdoor unit, the thermostat and the indoor unit.

Table 1 — NEC Class II Control Wiring

| 24 VOLTS | |
|-----------|------------------|
| WIRE SIZE | MAX. WIRE LENGTH |
| 18 AWG | 150 FT. |
| 16 AWG | 225 FT. |
| 14 AWG | 300 FT. |

- Table 1 defines maximum **total** length of low voltage wiring from outdoor unit, to indoor unit, and to thermostat.

- Mount the indoor thermostat in accordance with instruction included with the thermostat. Wire per appropriate hook-up diagram (included in these instructions).

G. COMPRESSOR START UP

After all electrical wiring is complete, SET THE THERMOSTAT SYSTEM SWITCH IN THE OFF POSITION SO COMPRESSOR WILL NOT RUN, and apply power by closing the system main disconnect switch. This will activate the compressor sump heat (where used). Do not change the Thermostat System Switch until power has been applied for one (1) hour. Following this procedure will prevent potential compressor overload trip at the initial start-up.

H. OPERATIONAL AND CHECKOUT PROCEDURES

Final phases of this installation are the unit Operational and Checkout Procedures which are found in this instruction (see page 8). To obtain proper performance, all units must be operated and charge adjustments made in accordance with procedures found in the Service Facts.

I. ELECTRIC HEATERS

Electric heaters, if used, are to be installed in the air handling device according to the instructions accompanying the air handler and the heaters.

J. START CONTROL

Some models have quick start components which are factory installed. For models that do not have factory installed start components, provisions are made for a field installed start kit accessory. When adding an accessory, follow the instructions provided with the kit.

K. OUTDOOR THERMOSTAT

An outdoor thermostat TAYSTAT250B may be field installed. For data, see wiring diagram attached to unit and instruction sheet packaged with outdoor thermostat.

L. SEACOAST SHIELD

BAYSEAC001 (Seacoast Kit) is available for application on units installed within one mile of salt water, including seacoasts and inland waterways.

M. TROUBLESHOOTING

TROUBLESHOOTING CHART — WHAT TO CHECK

| SYSTEM FAULTS | HIGH VOLTAGE WIRING | POWER SUPPLY | COMP. LOC. | START CAPACITOR | COND. START RELAY | COND. TRANSFORMER | COND. LOCAL | COND. LINE FUSE | REFRIG. COMPRESSOR | REFRIG. MOTOR | REFRIG. OIL CHARGE | EXCESSIVE START LOAD | WINDING SHORTS | O.D. AIR REFRIG. UNIT | TXV (SUCTION) SUPERHEAT | REF. CIRCUIT RESTRICTIONS | O.D. PAN SPEED SWITCH |
|--|---------------------|--------------|------------|-----------------|-------------------|-------------------|-------------|-----------------|--------------------|---------------|--------------------|----------------------|----------------|-----------------------|-------------------------|---------------------------|-----------------------|
| Liquid Pressure Too High | | | | | | | | | | | | | | | | | |
| Liquid Pressure Too Low | | | | | | | | | | S | P | | | | | S | S |
| Suction Pressure Too High | | | | | | | | | | S | P | P | | | | S | P |
| Suction Pressure Too Low | | | | | | | | | | | | S | | | | S | P |
| Liquid Refrig. Floodback TXV System | | | | | | | | | | | | | | | | S | S |
| Liquid Refrig. Floodback Capillary Tube System | | | | | | | | | | | | | | P | | S | S |
| I.D. Coil Frosting | | | | | | | | | | | P | | | | | | P |
| Compressor Runs Inadequate or No Cooling | | | | | | | | | | S | P | | | | | S | P |
| ELECTRICAL | | | | | | | | | | | | | | | | | |
| Compressor & O.D. Fan Do Not Start | P | P | | | | | | S | P | P | | | | | | | |
| Compressor Will Not Start But O.D. Fan Runs | P | S | P | P | P | | | | | | S | | | | | | |
| O.D. Fan Won't Start | P | | P | | | | | | | | | | | | | | |
| Compressor Hums But Won't Start | P | | P | P | P | S | | | | S | | | | | | | |
| Compressor Cycles on IOL | P | S | P | P | P | S | | | | P | S | P | S | S | S | | S |
| I.D. Blower Won't Start | P | S | | | | | | S | P | P | | | | | | | |

P - Primary Causes S - Secondary Causes

TYPICAL FIELD HOOK-UP DIAGRAMS

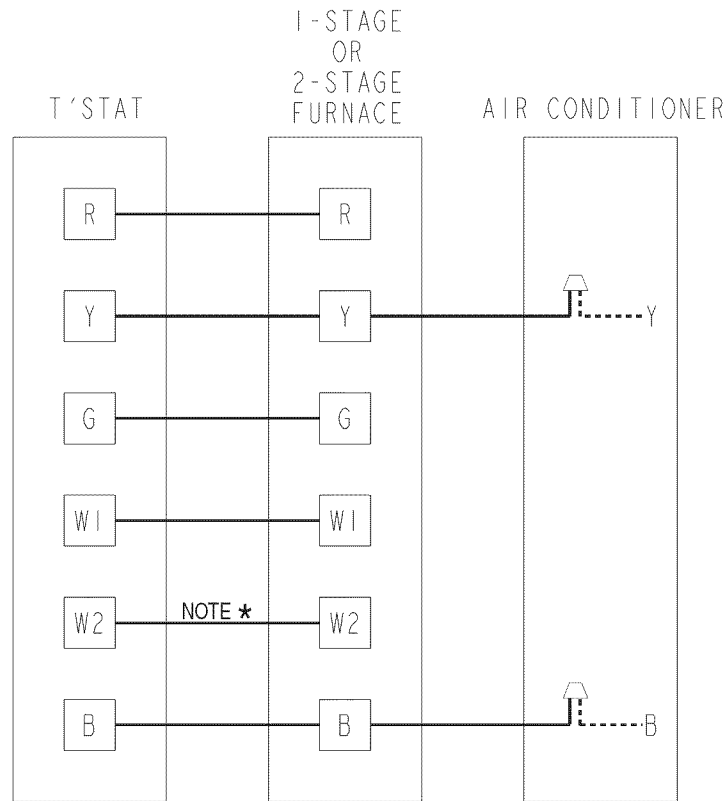
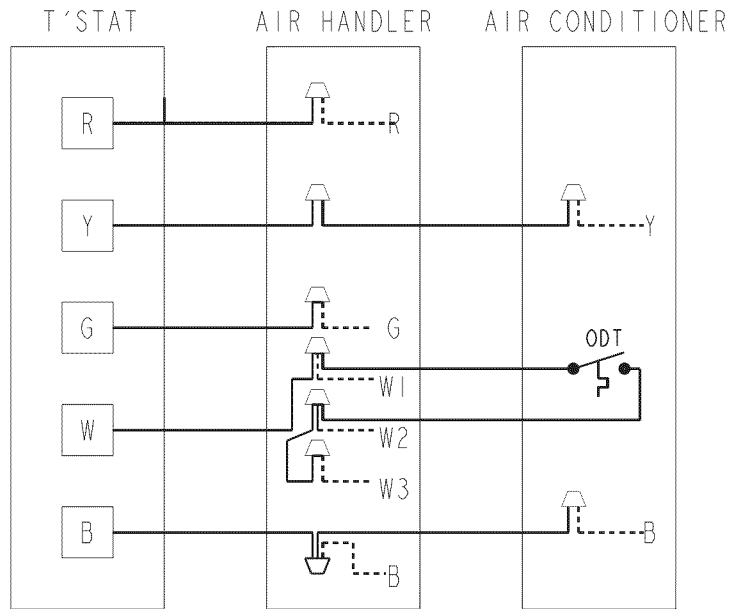

★W2 present only on 2 stage thermostat and furnace

Notes:

1. Be sure power supply agrees with equipment nameplate.
2. Power wiring and grounding of equipment must comply with local codes.
3. Low voltage wiring to be No. 18 AWG minimum conductor.
4. ODT-B must be set lower than ODT-A.
5. If outdoor thermostats (ODT) are not used, connect W1 to W2 and W3.

LEGEND

- FACTORY WIRING
- FIELD WIRING

Installer's Guide

2TTB0 & 2TTB2 OUTLINE DRAWING

Note: All dimensions are in MM (Inches).

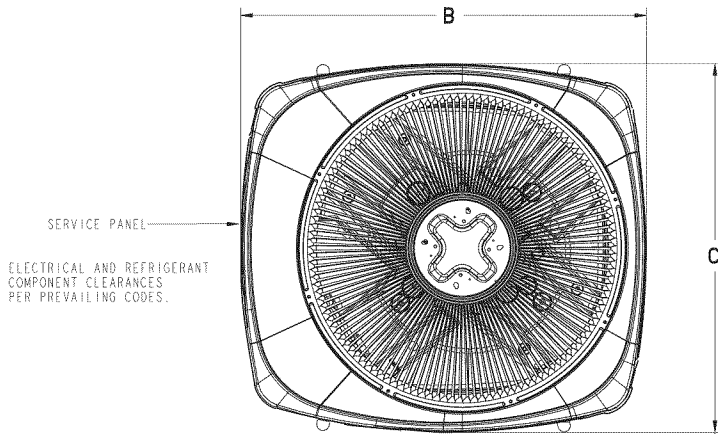

UNIT SHOULD BE PLACED SO ROOF RUN-OFF WATER DOES NOT POUR DIRECTLY ON UNIT, AND SHOULD BE AT LEAST 305 (12") FROM WALL AND ALL SURROUNDING SHRUBBERY ON TWO SIDES. OTHER TWO SIDES UNRESTRICTED.

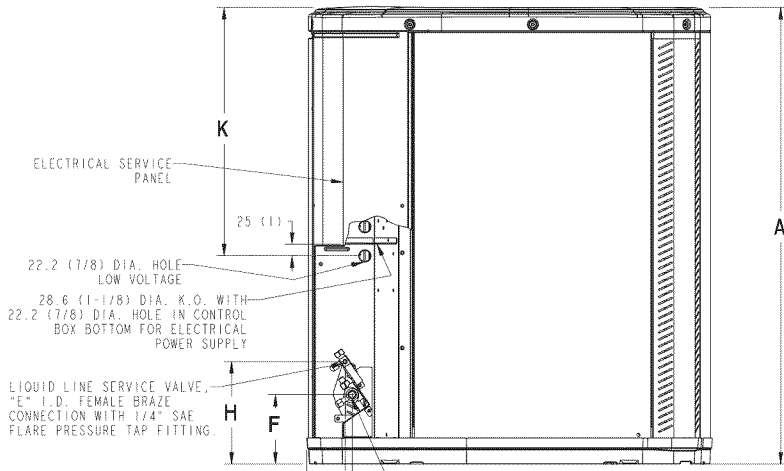

FIG. 1

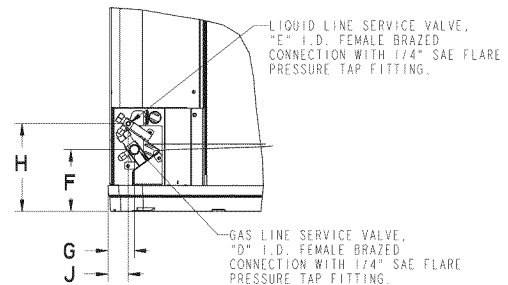

FIG. 2

| MODELS | BASE | FIG. | A | B | C | D | E | F | G | H | J | K |
|-----------|------|------|---------------|--------------|--------------|-------|------|-------------|------------|-------------|------------|----------|
| 2TTB0030A | 2 | 2 | 651 (25-5/8) | 724 (28-1/2) | 651 (25-5/8) | 3/4 | 5/16 | 127 (5) | 57 (2 1/4) | 181 (7-1/8) | 44 (1-3/4) | 457 (18) |
| 2TTB0036A | 2 | 2 | 651 (25-5/8) | 724 (28-1/2) | 651 (25-5/8) | 7/8 | 3/8 | 127 (5) | 57 (2-1/4) | 181 (7-1/8) | 44 (1-3/4) | 457 (18) |
| 2TTB0042A | 2 | 2 | 730 (28-3/4) | 724 (28-1/2) | 651 (25-5/8) | 7/8 | 3/8 | 137 (5-3/8) | 65 (2-5/8) | 210 (8-1/4) | 57 (2-1/4) | 457 (18) |
| 2TTB0048A | 2 | 2 | 730 (28-3/4) | 724 (28-1/2) | 651(25-5/8) | 1-1/8 | 3/8 | 137 (5-3/8) | 65 (2-5/8) | 210 (8-1/4) | 57 (2-1/4) | 457 (18) |
| 2TTB0060A | 3 | 1 | 832 (32-3/4) | 829 (32-5/8) | 756 (29-3/4) | 1-1/8 | 3/8 | 143 (5-5/8) | 92 (3-5/8) | 210 (8-1/4) | 79 (3-1/8) | 508 (20) |
| 2TTB2018A | 2 | 2 | 651 (25-5/8) | 724 (28-1/2) | 651 (25-5/8) | 5/8 | 1/4 | 127 (5) | 57 (2-1/4) | 181 (7-1/8) | 44 (1-3/4) | 457 (18) |
| 2TTB2024A | 2 | 2 | 730 (28-3/4) | 724 (28-1/2) | 651 (25-5/8) | 3/4 | 5/16 | 137 (5-3/8) | 65 (2-5/8) | 210 (8-1/4) | 57 (2-1/4) | 457 (18) |
| 2TTB2030A | 2 | 2 | 730 (28-3/4) | 724 (28-1/2) | 651 (25-5/8) | 3/4 | 5/16 | 137 (5-3/8) | 65 (2-5/8) | 210 (8-1/4) | 57 (2-1/4) | 457 (18) |
| 2TTB2036A | 2 | 2 | 832 (32-3/4) | 724 (28-1/2) | 651(25-5/8) | 7/8 | 3/8 | 137 (5-3/8) | 65 (2-5/8) | 210 (8-1/4) | 57 (2-1/4) | 457 (18) |
| 2TTB2042A | 3 | 2 | 832 (32-3/4) | 829 (32-5/8) | 756 (29-3/4) | 7/8 | 3/8 | 137 (5-3/8) | 86 (3-3/8) | 210 (8-1/4) | 79 (3-1/8) | 508 (20) |
| 2TTB2048A | 3 | 1 | 933 (36-3/4) | 829 (32-5/8) | 756 (29-3/4) | 1-1/8 | 3/8 | 143 (5-5/8) | 92 (3-5/8) | 210 (8-1/4) | 79 (3-1/8) | 508 (20) |
| 2TTB2060A | 3 | 1 | 933 (36-3/4) | 829 (32-5/8) | 756 (29-3/4) | 1-1/8 | 3/8 | 143 (5-5/8) | 92 (3-5/8) | 210 (8-1/4) | 79 (3-1/8) | 508 (20) |

From Dwg. 21D153074 Rev. 5

MOUNTING HOLE LOCATION

Note: All dimensions are in MM (Inches).

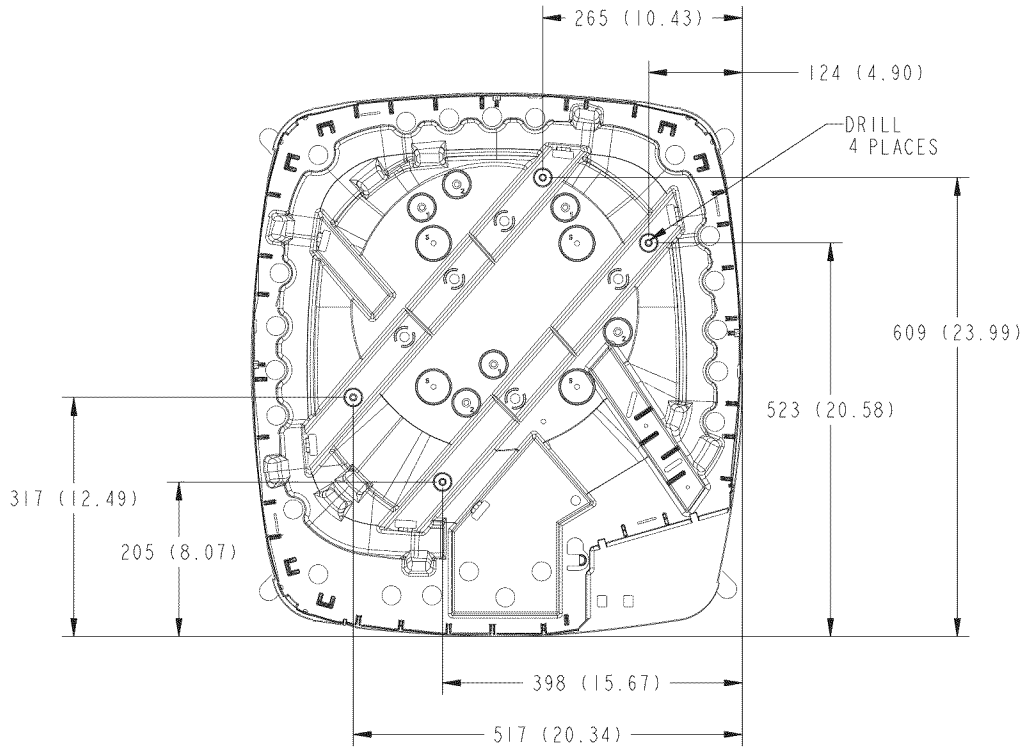

BASE 2

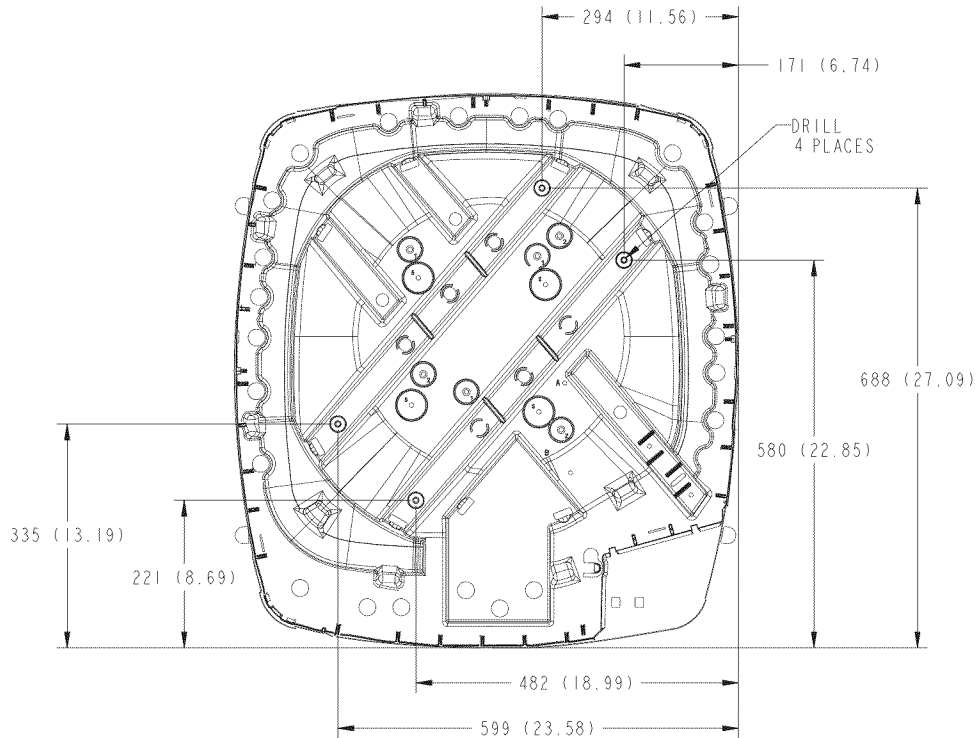

BASE 3

NOTE: For model base size, see table on page 6.

From Dwg. 21D152637 Rev. 1

Installer's Guide

CHECKOUT PROCEDURE

After installation has been completed, it is recommended that the entire system be checked against the following list:

1. Refrigerant Line, Leak checked []
2. Suction Lines and Fittings properly insulated []
3. Have all Refrigerant Lines been secured and isolated properly? []
4. Have passages through masonry been sealed? If mortar is used, prevent mortar from coming into direct contact with copper tubing []
5. Verify tightness of all electrical connects []
6. Observe outdoor fan during on cycle for clearance and smooth operation []
7. Indoor coil drain line drains freely. Pour water into drain pan []
8. Supply registers and return grilles open and unobstructed []
9. Return air filter installed []
10. Thermostat thermometer is accurate. Check against a reliable thermometer. Adjust per instructions with thermostat []
11. Is correct speed tap being used? (Indoor blower motor) []
12. Operate complete system in each mode to insure safe operation. []

CHECKOUT PROCEDURE WITH MAIN POWER DISCONNECTS CLOSED (ON)

| Step No. | TO CHECK | INDOOR THERMOSTAT SWITCH SETTING | | | | | COMPONENT OPERATION | | | | |
|--------------------------------------|--|----------------------------------|--------|--------|------------|----|---------------------|------------------|-----------------|---------------------|-----------------------|
| | | Off | ① Cool | ① Heat | Fan Switch | | Indoor Blower Runs | Outdoor Fan Runs | Compressor Runs | ③ Comp. Sump Heater | Furnace Heat Comes On |
| | | | | | Auto | On | | | | | |
| 1 | Sump Heat | X | | | X | | | | | X | |
| 2 | Indoor Fan Operation | X | | | | X | X | | | X | |
| 3 | Cooling Operation | | X | | X | | X | X | X | X | |
| 4 | Checking Performance & Charge | | X | | X | | X | X | X | X | |
| ← USE CHARTS ATTACHED TO O.D. UNIT → | | | | | | | | | | | |
| 5 | Heating ② | | | X | X | | X | | | X | X |
| 6 | Inform owner on how to operate system and what to expect of it. At the same time deliver Owner's Use and Care Booklet. | | | | | | | | | | |

- ① Also set thermostat dial to call for cooling or heating as necessary.
- ② Check only necessary if heating unit is used for indoor section and wiring has been disturbed during installation of cooling equipment.
- ③ When applicable.



Trane
A business of
American Standard Companies
www.trane.com

| | | |
|-------------------------|------------------------------------|------|
| Literature Order Number | 2TTB0-IN-2 | P.I. |
| File Number | SV-UN-S/S-2TTB0-IN-2 2/03 | |
| Supersedes | New | |
| Stocking Location | PI Louisville & Webb/Mason-Houston | |

Trane has a policy of continuous product and product data improvement and it reserves the right to change design and specifications without notice.