



18 - CD24D1 - 2

Available in French Canadian (FC)

Installer's Guide

Variable Speed, 2-Stage, 80% Upflow/ Horizontal Gas-Fired Furnaces, "Fan Assisted Combustion System" with Whole House Air Cleaner

- *UD2B060AFV32A
- *UD2B080AFV32A
- *UD2C080AFV42A
- *UD2B100AFV32A
- *UD2D120AFV52A

* __First letter may be "A" or "T"

ALL phases of this installation must comply with NATIONAL, STATE AND LOCAL CODES

IMPORTANT — This Document is **customer property** and is to remain with this unit. Please return to service information pack upon completion of work.



For VENT SIZING INFORMATION see:

USA —
National Fuel Gas Code ANSI Z223.1/ NFPA 54 (latest version)

CANADA —
Natural Gas Installation Code CAN/ CGA-B149.1 (latest version)
Propane Installation Code CAN/ CGA-B149.2 (latest version)

USA/ CANADA ALTERNATE —
Category I Venting Guide Pub. No. 18-CH23D1 (latest version)



This unit is equipped with an integrated high efficiency Whole House Air Cleaner. Careful consideration must be taken in the installation process to avoid personal injury, property damage or equipment damage. These instructions do not cover all variations in systems or provide for every possible contingency. Should further information be desired or particular problems arise which are not covered sufficiently by this manual, contact your local distributor or the manufacturer as listed on the Furnace nameplate.

In addition, these Furnaces are suitable for installation in an attic, garage or crawl space with ducted supply and return air.

Upflow/ Horizontal*

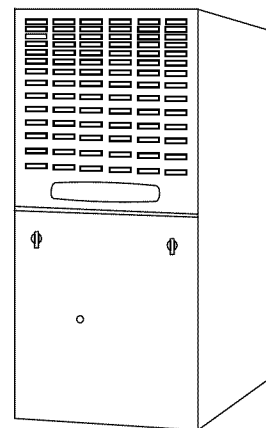

***Units are BOTTOM RETURN only**
Horizontal Conversion for these furnaces may be left or right side rotation.

Safety signal words are used to designate a degree or level of seriousness associated with a particular hazard. The signal words for safety markings are **WARNING** and **CAUTION**.

- a. **WARNING** indicates a potentially hazardous situation which, if not avoided, could result in death or serious injury.
- b. **CAUTION** indicates a potentially hazardous situation which, if not avoided, may result in minor or moderate injury. It is also used to alert against unsafe practices and hazards involving only property damage.

Installer's Guide

SAFETY SECTION

WARNING

CARBON MONOXIDE POISONING HAZARD

Failure to follow the steps outlined below for each appliance connected to the venting system being placed into operation could result in carbon monoxide poisoning or death.

The following steps shall be followed for each appliance connected to the venting system being placed into operation, while all other appliances connected to the venting system are not in operation:

1. Seal any unused openings in the venting system.
2. Inspect the venting system for proper size and horizontal pitch, as required in the National Fuel Gas Code, ANSI Z223.1/NFPA 54 or the CSA B149.1 *Natural Gas and Propane Installation Code* and these instructions. Determine that there is no blockage or restriction, leakage, corrosion and other deficiencies which could cause an unsafe condition.
3. As far as practical, close all building doors and windows and all doors between the space in which the appliance(s) connected to the venting system are located and other deficiencies which could cause an unsafe condition.
4. Close fireplace dampers.
5. Turn on clothes dryers and any appliance not connected to the venting system. Turn on any exhaust fans, such as range hoods and bathroom exhausts, so they are operating at maximum speed. Do not operate a summer exhaust fan.
6. Follow the lighting instructions. Place the appliance being inspected into operation. Adjust the thermostat so appliance is operating continuously.
7. Test for spillage from draft hood equipped appliances at the draft hood relief opening after 5 minutes of main burner operation. Use the flame of a match or candle.
8. If improper venting is observed during any of the above tests, the venting system must be corrected in accordance with the National Fuel Gas Code, ANSI Z221.1/NFPA 54 and/or CSA B149.1 *Natural Gas and Propane Installation Code*.
9. After it has been determined that each appliance connected to the venting system properly vents where tested as outlined above, return doors, windows, exhaust fans, fireplace dampers and any other gas-fired burning appliance to their previous conditions of use.

WARNING

FIRE OR EXPLOSION HAZARD

Failure to follow the safety warnings exactly could result in serious injury, death or property damage. Improper servicing could result in dangerous operation, serious injury, death, or property damage.

WARNING

Failure to follow safety warnings exactly, could result in a fire or explosion causing property damage, personal injury or loss of life.

- Do not store or use gasoline or other flammable vapors and liquids in the vicinity of this or any other appliance.
- **WHAT TO DO IF YOU SMELL GAS**
 - Do not try to light any appliance.
 - Do not touch any electrical switch; do not use any phone in your building.
 - Immediately call your gas supplier from a neighbor's phone. Follow the gas supplier's instructions.
 - If you cannot reach your gas supplier, call the fire department.
- Installation and service must be performed by a qualified installer, service agency or the gas supplier.

The following safety practices and precautions must be followed during the installation, servicing, and operation of this Furnace.

1. Use only with the type of gas approved for this Furnace. Refer to the Furnace rating plate.
2. Install this Furnace only in a location and position as specified in "Location and Clearances" (page 4) of these instructions.
3. Provide adequate combustion and ventilation air to the Furnace space as specified in "Air for Combustion and Ventilation" (page 9), of these instructions.
4. Combustion products must be discharged outdoors. Connect this Furnace to an approved vent system only, as specified in the "Venting" section (page 12), of these instructions.
5. Never test for gas leaks with an open flame. Use a commercially available soap solution made specifically for the detection of leaks to check all connections, as specified in the "Gas Piping" section of these instructions on page 19.
6. Always install the Furnace to operate within the Furnace's intended temperature-rise range with a duct system which has an external static pressure within the allowable range, as specified on the unit rating plate. Airflow with temperature rise for cfm versus static is shown in the Service Facts accompanying this Furnace.
7. When a Furnace is installed so that supply ducts carry air circulated by the Furnace to areas outside the space containing the Furnace, the return air shall also be handled by a duct(s) sealed to the Furnace casing and terminating outside the space containing the Furnace.

⚠ CAUTION

To prevent shortening its service life, the Furnace should not be used as a "Construction Heater" during the finishing phases of construction until the requirements listed in item 9, a-i of the safety section of this publication have been met. Condensate in the presence of chlorides and fluorides from paint, varnish, stains, adhesives, cleaning compounds, and cement create a corrosive condition which may cause rapid deterioration of the heat exchanger.

⚠ CAUTION

Chemicals used to during construction may cause damage to the COLLECTION CELL.

⚠ WARNING

DO NOT USE SEMI-RIGID METALLIC GAS CONNECTORS (FLEXIBLE GAS LINES) WITHIN THE FURNACE CABINET.

FAILURE TO FOLLOW THIS WARNING COULD RESULT IN PROPERTY DAMAGE, PERSONAL INJURY OR DEATH.

8. A gas-fired Furnace for installation in a residential garage must be installed as specified in "Location and Clearances" section (page 4) , of these instructions.
9. The Furnace may be used for temporary heating of buildings or structures under construction only when the following conditions have been met:
 - a. The Furnace venting system must be complete and installed per manufacturers instructions.
 - b. The Furnace is controlled only by a room Comfort Control (no field jumpers).
 - c. The Furnace return air duct must be complete and sealed to the Furnace.
 - d. The Furnace input rate and temperature rise must be verified to be within nameplate marking.
 - e. 100% of the Furnace combustion air requirement must come from outside the structure.
 - f. The Furnace return air temperature range is between 55° and 80° Fahrenheit.
 - g. Clean the Furnace, duct work, and components upon substantial completion of the construction process, and verify Furnace and whole house air cleaner operating conditions including ignition, input rate, temperature rise and venting, according to the manufacturer's instructions.
 - h. Remove the Whole House Air Cleaner and store in a clean, dry location during the construction process. To be reinstalled when construction is complete. See page 27 for proper air cleaner removal.
 - i. An external field supplied air filter must be used during construction.

Contents

Safety Section	2
Installation Instructions	4
General	4
Location and Clearances	4
Outline Drawings	6
Upflow Installation	7
Horizontal Installation	7
Air For Combustion and Ventilation	9
Duct Connections	10
General Venting	12
Venting Routed Through a Masonry Chimney	12
Field Wiring Diagrams	14
Electrical Connections	19
Gas Piping	19
Combustion and Input Check	21
High Altitude Derate	22
Start-up and Adjustment	23
Preliminary Inspections	23
Lighting Instructions	23
Sequence of Operation	24
Control and Safety Switch Adjustments	24
Conditions Affecting System Operation	26
Whole House Air Cleaner Maintenance	26
IFC Error Flash Codes	28
Checkout Procedure	30

10. This product must be gas piped by a Licensed Plumber or Gas Fitter in the Commonwealth of Massachusetts.

Installer's Guide

GENERAL INSTALLATION INSTRUCTIONS

The manufacturer assumes no responsibility for equipment installed in violation of any code or regulation.

It is recommended that Manual J of the Air Conditioning Contractors Association (ACCA) or A.R.I. 230 be followed in estimating heating requirements. When estimating heating requirements for installation at Altitudes above 2000 ft., remember the gas input must be reduced (See combustion and input check page 21).

Material in this shipment has been inspected at the factory and released to the transportation agency without known damage. Inspect exterior of carton for evidence of rough handling in shipment. Unpack carefully after moving equipment to approximate location. If damage to contents is found, report the damage immediately to the delivering agency.

Codes and local utility requirements governing the installation of gas fired equipment, wiring, plumbing, and flue connections must be adhered to. In the absence of local codes, the installation must conform with latest edition of the National Fuel Gas Code ANSI Z223.1 • National Installation Code, CAN/CGA B149.1. The latest code may be obtained from the American Gas Association Laboratories, 400 N. Capitol St. NW, Washington D.C. 20001.

1-800-699-9277 or www.aga.org

These furnaces have been classified as Fan Assisted Combustion system CATEGORY I furnaces as required by ANSI Z21.47 "latest edition" and CAN/CGA 2.3. Therefore they do not require any special provisions for venting other than what is indicated in these instructions. (Category I defined on pages 12 and 13).

LOCATION AND CLEARANCES

WARNING

Do NOT install the Furnace directly on carpeting, tile or other combustible material other than wood flooring.

CAUTION

Do NOT install the Furnace in a corrosive or contaminated atmosphere.

Failure to follow this warning could result in early equipment failure.

The location of the Furnace is normally selected by the architect, the builder, or the installer. However, before the Furnace is moved into place, be sure to consider the following requirements:

1. Is the location selected as near the chimney or vent and as centralized for heat distribution as practical?
2. Do all clearances between the Furnace and enclosure equal or exceed the minimums stated in Clearance Table on the Outline Drawings?
3. Is there sufficient space for servicing the Furnace and other equipment? A minimum of 24 inches front accessibility to the Furnace must be provided. Any access door or panel must permit removal of the largest component.
4. Are there at least 3 inches of clearance between the Furnace combustion air openings in the front panel and any closed panel or door provided?
5. Are the ventilation and combustion air openings large enough and will they remain unobstructed? If outside air is used, are the openings set above the highest snow accumulation level? (See the Air for Combustion and Ventilation section, page 9)
6. **A heavy gauge steel plate is attached to the bottom of the unit for protection during shipping and handling prior to the unit installation. Leave this plate in place until the unit is ready to be connected to the ductwork.**
7. A Pre-filter is not required to be installed with the furnace containing a Whole House Air Cleaner. If the use of a Pre-Filter is desired, it must be installed at least 6" away from the Whole House Air Cleaner. The additional pressure drop of the Pre-Filter must be considered during duct design or evaluation to ensure proper airflow.
8. Allow sufficient height in supply plenum above the Furnace to provide for cooling coil installation, if the cooling coil is not installed at the time of this Furnace installation.
9. A Furnace shall be installed so electrical components are protected from water.
10. DO NOT use silicon based sealant in the airstream. This causes a coating on the FIELD CHARGER pins that will decrease the efficiency of the air cleaner.
11. Allow a minimum of 24 inches clearance in front of the air cleaner to permit removal of COLLECTION CELL and FIELD CHARGER.
12. DO NOT install furnace where the air cleaner can be exposed to UV light.

NOTE: Do NOT install an atomizing style humidifier in the return plenum of this unit.

13. Flow-through Bypass Humidifiers

Excessive bypass air may cause water blow-off, which will adversely affect system operation and air cleaner performance. To verify bypass airflow, follow the Bypass Humidifier Pre-Installation Check-out and Set-Up Procedures available through your local distributor. Ask for publication number 18-CH37D1-1.

Steam and Flow-through Fan Power Duct-mounted Humidifiers

Follow the humidifier installation instructions. These should only be installed on the supply air side of the system.

Other Duct Mounted Humidifiers are not recommended for installation with the air cleaner.

14. If the Furnace is installed in a **residential garage**, it must be installed so that the burners, and the ignition source are located not less than 18 inches above the floor and the Furnace must be located or protected to avoid physical damage from vehicles.
15. The whole house air cleaner is designed to run at a maximum indoor relative humidity of 65%.

Figure 1. COMPONENTS OF THE INTEGRATED WHOLE HOUSE AIR CLEANER

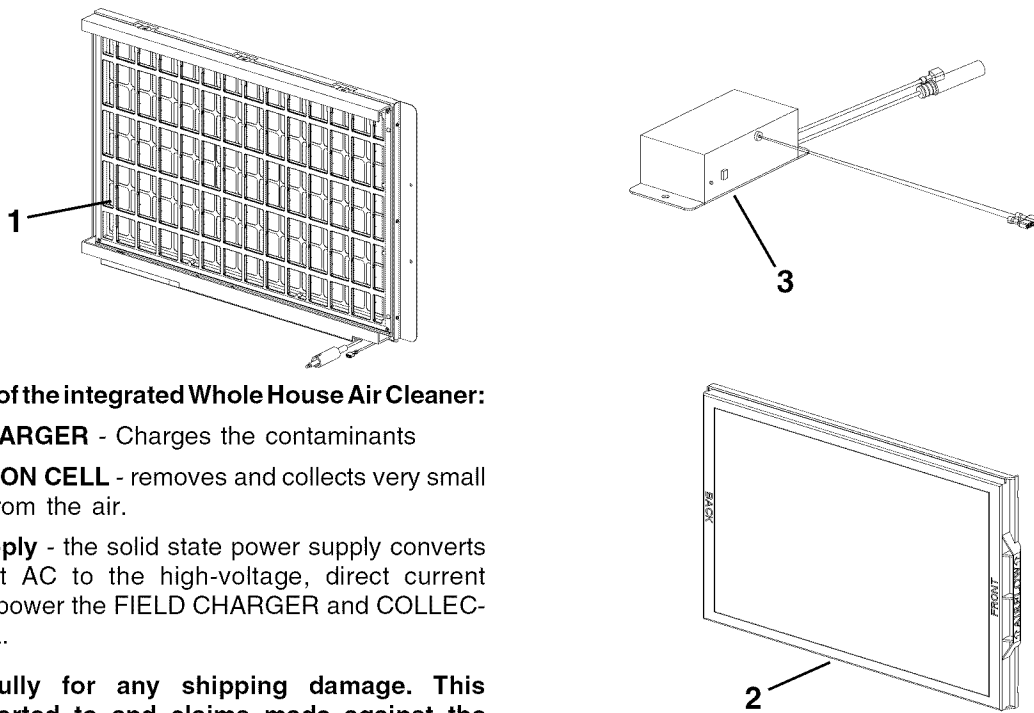

Components of the integrated Whole House Air Cleaner:

- 1) **FIELD CHARGER** - Charges the contaminants
- 2) **COLLECTION CELL** - removes and collects very small impurities from the air.
- 3) **Power Supply** - the solid state power supply converts the 24 Volt AC to the high-voltage, direct current required to power the FIELD CHARGER and COLLECTION CELL.

Check carefully for any shipping damage. This must be reported to and claims made against the transportation company immediately. Check to be sure all major components are in the unit. Any missing parts should be reported to your supplier at once, and replaced with authorized parts only.

Installer's Guide

*UD2 OUTLINE DRAWING (ALL DIMENSIONS ARE IN INCHES)

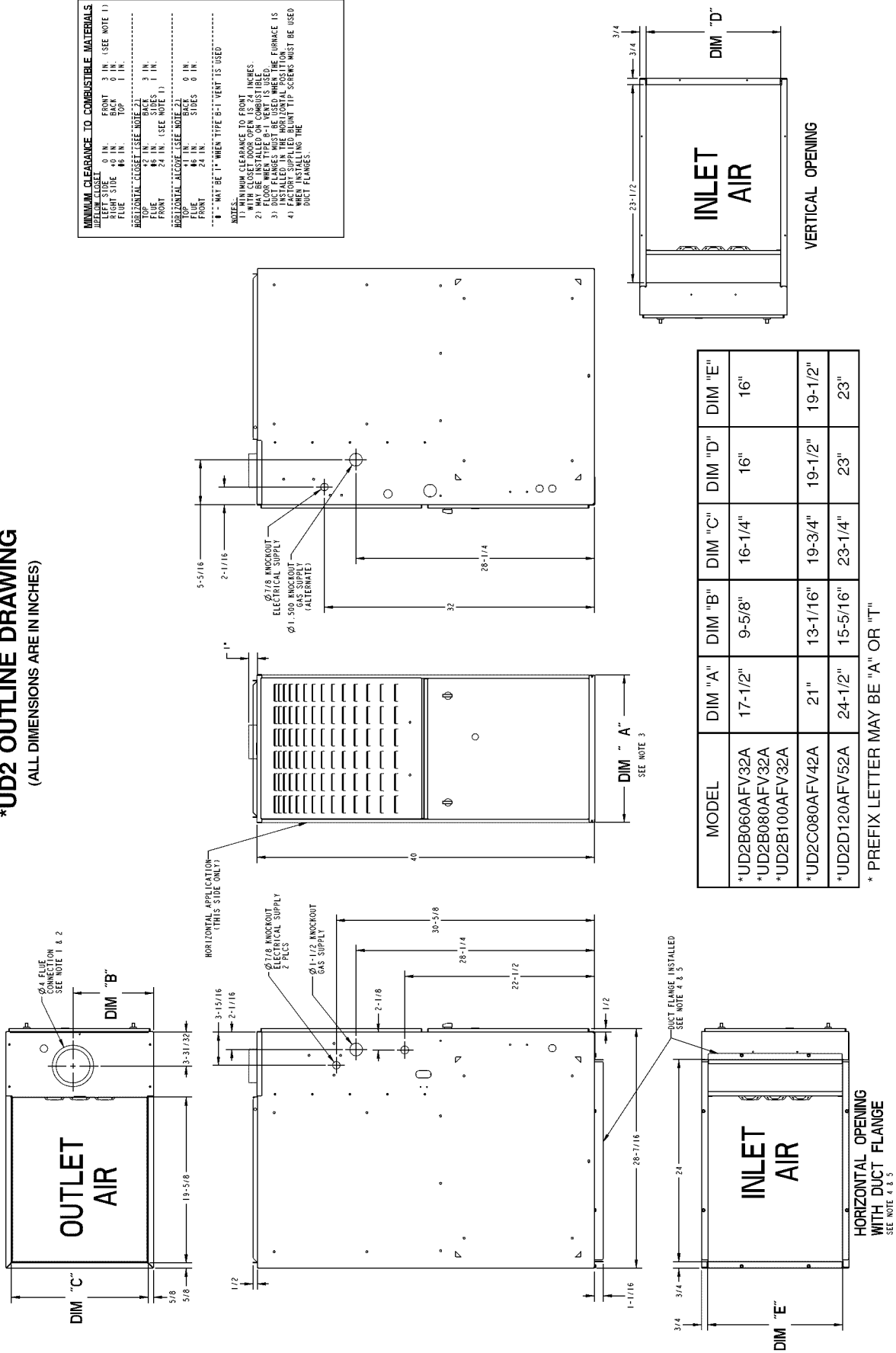

MODEL	DIM "A"	DIM "B"	DIM "C"	DIM "D"	DIM "E"
*UD2B060AFV32A	17-1/2"	9-5/8"	16-1/4"	16"	16"
*UD2B080AFV32A					
*UD2B100AFV32A					
*UD2C080AFV42A	21"	13-1/16"	19-3/4"	19-1/2"	19-1/2"
*UD2D120AFV52A	24-1/2"	15-5/16"	23-1/4"	23"	23"

* PREFIX LETTER MAY BE "A" OR "T"

Bottom Return ONLY

INSTALLATION INSTRUCTIONS

⚠ CAUTION

Bottom panel for furnace to remain in place until unit reaches final installation location. If bottom panel is removed before installation the collection cell and field charger must also be removed to protect installation personnel.

⚠ CAUTION

Remove the COLLECTION CELL and remove and discard the cardboard over the cell.

NOTE: No sheetmetal screws may be used from 0-4" from the bottom of the unit. Screws will interfere with the Air Cleaner. See Figure 4.

REMOVING THE BOTTOM PLATE

- Once the furnace is in place, remove the two screws located at the front bottom corners of the Furnace.
- Lean the furnace back slightly and remove the bottom panel.
- Replace the two screws removed in step a.

REMOVING THE COLLECTION CELL AND FIELD CHARGER

When COLLECTION CELLS and FIELD CHARGER must be removed, follow the steps below.

- Remove the lower furnace door.
- Remove the four screws holding the inner blower panel and remove panel. Set aside in a safe place until the unit is set in place and ready to start up.
- Remove the COLLECTION CELL by sliding forward. Remove the cardboard from the COLLECTION CELL and discard. Set aside in a safe place until the unit is set in place and ready to start up.
- Disconnect the Green return wire and the Red high voltage wire. Twist and pull the connector on the Red wire to release.
- Remove the two hold down screws on the bottom of the FIELD CHARGER and retain.
- Remove the Field Charger. Set aside in a safe place until the unit is set in place and ready to start up.
- Set furnace in place. Repeat step a-g in reverse order. Do Not put cardboard back in Furnace. Inner blower door MUST be put back into place.

UPFLOW INSTALLATION

Standoffs and screws (See Figure 2) are included with the cased coils for attachment to the Furnace. There are clearance alignment holes near the bottom of the coil wrapper. Drill screws are used to engage the Furnace top flanges. The standoff is inserted into the cabinet alignment hole. The drill screws are inserted through the standoffs then screwed into the Furnace flange. The coil is always placed downstream of the Furnace airflow. The above instructions apply only if the coil is on top of an upflow Furnace.

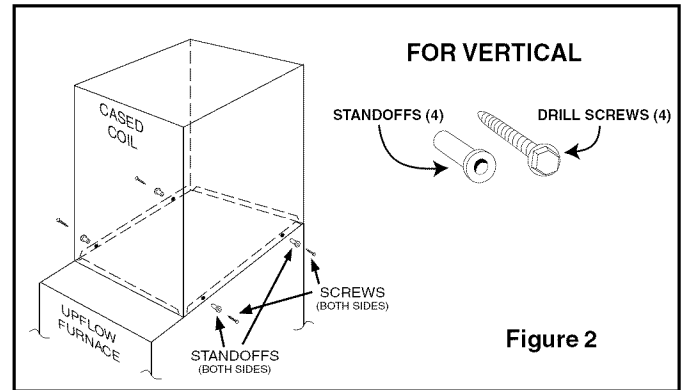

Figure 2

HORIZONTAL INSTALLATION

The coil and furnace must be fully supported when used in the horizontal position.

IMPORTANT:

The 2/4TXC cased coil must be placed downstream of the furnace. In horizontal installations, the apex of the coil may point either toward or away from the furnace. See the 2/4TXC coil Installer's Guide for more details.

The cased coil is secured to the Furnace and both the Furnace and the cased coil must be properly supported. The brackets mount using the rear screws on the coil case and use the screws provided to secure the bracket to the Furnace. The remaining bracket is placed as close to center as possible (horizontally) between the coil case front and the upflow Furnace, converted to horizontal, aligns and attaches to the TXC coil. However, the coil requires additional support.

The horizontal Furnace installation in an attic should be on a service platform large enough to allow for proper clearances on all sides and service access to the front of the Furnace (See Figure 3 & Clearance Table 1). Line contact is only permissible between lines formed by intersections of the top and two sides of the furnace casing and building joists, studs, or framing.

Installer's Guide

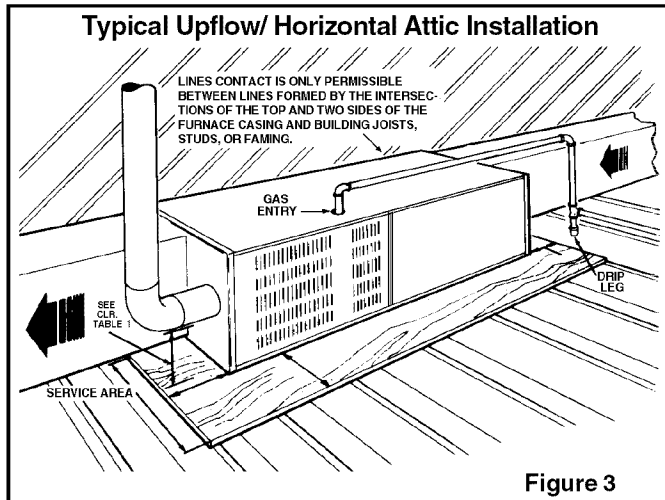

Figure 3

The Furnace may be placed horizontally in a crawl space on a pad or other noncombustible material which will raise the unit for sufficient protection from moisture. **The Furnace must be supported at both ends and the middle when installed horizontally. The Furnace must also be elevated approximately 4-6 inches to allow clearance for the condensate drain to exit the cabinet in the horizontal position.**

The horizontal Furnace may also be suspended from the joists using all-thread rods with a substantial metal support frame that supports the entire length of the furnace. The rods need to be of sufficient length to allow for proper clearances from combustible materials. The frame needs to be at least 32" in length to allow for access to service panels.

If the Furnace is suspended using steel strap, it must be supported at all four corners and in the middle at the front of the Furnace.

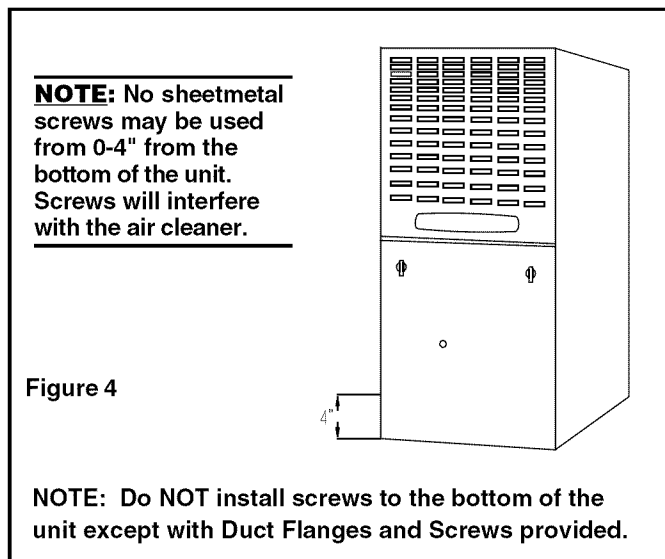

Figure 4

NOTE: Do NOT install screws to the bottom of the unit except with Duct Flanges and Screws provided.

GUIDE FOR THE INSTALLATION OF DUCT FLANGES

⚠ CAUTION

Failure to use pre-drilled holes and the factory provided screws can potentially damage air cleaner components.

Materials

- Duct Flanges
 - Two 23.5" Flanges
 - Two Additional Flanges
 - 15.92" (for 17.5" cabinet)
 - 19.42" (for 21" cabinet)
 - 21.92" (for 24.5" cabinet)
- Screws
 - Eight 5/16" Blunt Tip Screws with 5/16" Hex Head

Steps

1. See Figures 5, 6, and 7 for flange orientation.
2. Attach flanges 1, 2, and 3 (Fig 7) to the unit using the factory provided screws and the pre-drilled holes in the wrapper. Flanges 1 and 2 are the 23.5" flanges that are generic to all units. Flange 3 will be one of two short flanges and the length of which is dependent on the cabinet size.
3. Attach flange 4 (Fig 7) to the duct work (Flanges should be inside duct work). Flange 4 is the remaining short flange.
4. Place duct work with single flange over the 3 flanges that are currently attached to the unit
5. Attach duct work to remaining 3 flanges.
6. Attach the front flange from step 3 to the unit by drilling 1/8" holes into the bottom channel. Use the factory provided 5/16" blunt tip screws to attach.
7. Use field supplied material to make an adequate seal. **DO NOT use silicon based sealant in the airstream.**

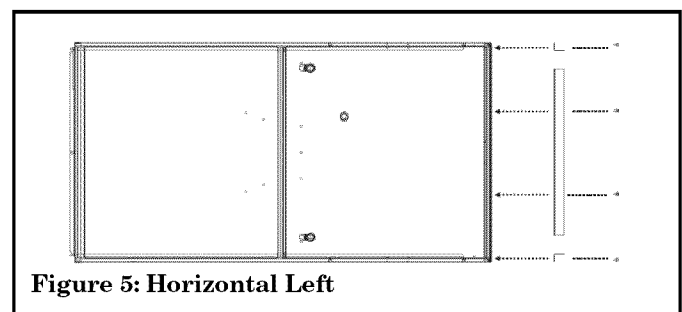

Figure 5: Horizontal Left

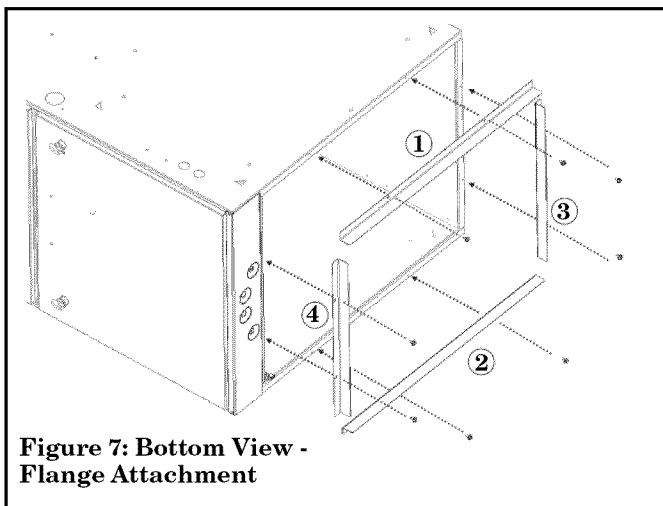
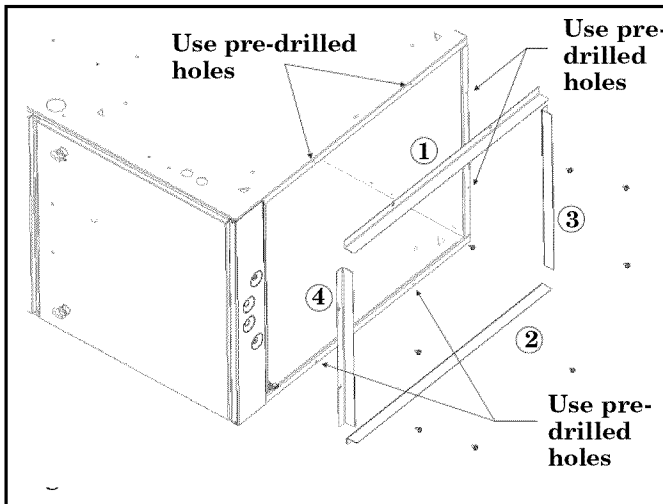

Figure 7: Bottom View - Flange Attachment

Table 1

Minimum Clearance to Combustible Materials			
Upflow Closet			
Left Side	0 inches	Front	3 inches (note 1)
Right Side	0 inches	Back	0 inches
Flue	6 inches *	Top	1 inch
Horizontal Closet (see note 2)			
Top	2 inches	Back	3 inches
Flue	6 inches *	Sides	1 inch
Front	18 inches (note 1)		
Horizontal Alcove (see note 2)			
Top	1 inch	Back	0 inches
Flue	6 inches	Sides	0 inches
Front	18 inches		

* May be 1" when type B-1 vent is used
 NOTES:
 1) Minimum clearance to front on *UD2D120 is 6 inches
 2) May be installed on combustible floor when type B-1 vent is used.

AIR FOR COMBUSTION AND VENTILATION

Adequate flow of combustion and ventilating air must not be obstructed from reaching the Furnace. Air openings provided in the Furnace casing must be kept free of obstructions which restrict the flow of air. Airflow restrictions affect the efficiency and safe operation of the Furnace. Keep this in mind should you choose to remodel or change the area which contains your Furnace. Furnaces must have a free flow of air for proper performance.

Provisions for combustion and ventilation air shall be made in accordance with "latest edition" of Section 5.3, Air for Combustion and Ventilation, of the National Fuel Gas Code, ANSI Z223.1, or Sections 7.2, 7.3 or 7.4 of CSA B149.1 Installation Codes, and applicable provisions of the local building codes. Special conditions created by mechanical exhausting of air and fireplaces must be considered to avoid unsatisfactory Furnace operation.

Furnace locations may be in "confined space" or "unconfined space". Unconfined space is defined in Table 2 and Figure 8. These spaces may have adequate air by infiltration to provide air for combustion, ventilation, and dilution of flue gases. Buildings with tight construction (for example, weather stripping, heavily insulated, caulked, vapor barrier, etc.), may need additional air provided as described for confined space.

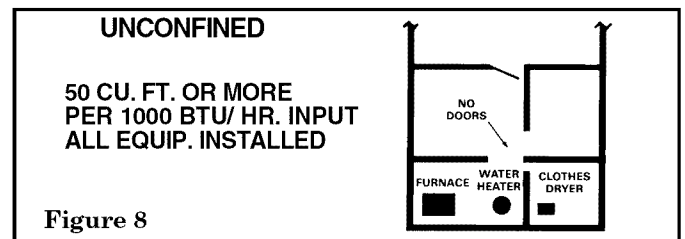

Figure 8

TABLE 2

MINIMUM AREA IN SQUARE FEET FOR UNCONFINED SPACE INSTALLATIONS	
FURNACE MAXIMUM BTUH INPUT RATING	WITH 8 FT. CEILING MINIMUM AREA IN SQUARE FEET OF UNCONFINED SPACE
60,000	375
80,000	500
100,000	625
120,000	750
140,000	875

1. All air from inside the building as in Figure 10: The confined space shall be provided with two permanent openings communicating directly with an additional room(s) of sufficient volume so that the combined volume of all spaces meets the criteria for an unconfined space. The total input of all gas utilization equipment installed in the combined space shall be considered in making this determination. Refer to Table 3, for minimum open areas required.

Installer's Guide

2. All air from outdoors as in Figure 11: The confined space shall be provided with two permanent openings, one commencing within 12 inches of the top and one commencing within 12 inches of the bottom of the enclosure.

The openings shall communicate directly, or by ducts, with the outdoors or spaces (crawl or attic) that freely communicate with the outdoors. Refer to Table 3, for minimum open areas required.

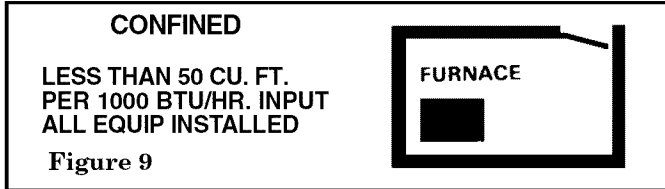

**TABLE 3
MINIMUM FREE AREA IN SQUARE INCHES
EACH OPENING (FURNACE ONLY)**

Furnace Maximum BTUH/INPUT Rating	Air From Inside	Air From Outside	
		Vertical Duct	Horizontal Duct
60,000	100	15	30
80,000	100	20	40
100,000	100	25	50
120,000	120	30	60
140,000	140	35	70

Confined spaces are installations with less than 50 cu. ft. of space per 1000 BTU/ hr input from all equipment installed. Confined space is defined in Figure 9. Air for combustion and ventilation requirements can be supplied from inside the building as in Figure 10 or from the outdoors, as in Figure 11.

3. The following types of installations will **require** use of OUTDOOR AIR for combustion, due to chemical exposures:

- * Commercial buildings
 - * Buildings with indoor pools
 - * Furnaces installed in commercial laundry rooms
 - * Furnaces installed in hobby or craft rooms
 - * Furnaces installed near chemical storage areas.
- Exposure to the following substances in the combustion air supply will also require OUTDOOR AIR for combustion:
- * Permanent wave solutions
 - * Chlorinated waxes and cleaners
 - * Chlorine based swimming pool chemicals
 - * Water softening chemicals
 - * Deicing salts or chemicals
 - * Carbon Tetrachloride
 - * Halogen type refrigerants
 - * Cleaning solvents (such as perchloroethylene)
 - * Printing inks, paint removers, varnish, etc.
 - * Hydrochloric acid
 - * Cements and glues
 - * Antistatic fabric softeners for clothes dryers
 - * Masonry acid washing materials

NOTE: Extended warranties are NOT available in some instances. Extended warranty does NOT cover repairs to equipment installed in establishments with corrosive atmospheres, including but limited to, dry cleaners, beauty shops, and printing facilities.

DUCT CONNECTIONS

Air duct systems should be installed in accordance with standards for air conditioning systems, National Fire Protection Association Pamphlet No. 90. They should be sized in accordance with ACCA Manual D or whichever is applicable.

Central Furnaces, when used in connection with cooling units, shall be installed in parallel or on the upstream side of the cooling coil to avoid condensation in the heat exchanger. With a parallel flow arrangement, the dampers or other means used to control flow of air shall be adequate to prevent chilled air from entering the Furnace, and if manually operated, must be equipped with means to prevent operation of either unit unless the damper is in full heat or cool position.

On any job, flexible connections of nonflammable material may be used for return air and discharge connections to prevent transmission of vibration. Though these units have been specifically designed for quiet, vibration free operation, air ducts can act as sounding boards and could, if poorly installed, result in vibration to the annoyance level.

When the Furnace is located in a utility room adjacent to the living area, the system should be carefully designed with returns to minimize noise transmission through the return air grille. Although these Furnaces are designed with large blowers operating at moderate speeds, any blower moving a high volume of air will produce audible noise which could be objectionable when the unit is located very close to a living area. It is often advisable to route the return air ducts under the floor or through the attic. Such design permits the installation of air return remote from the living area (i.e. central hall).

When the Furnace is installed so that the supply ducts carry air circulated by the Furnace to areas outside the space containing the Furnace, the return air shall also be handled by a duct(s) sealed to the Furnace and terminating outside the space containing the Furnace.

Where there is no complete return duct system, the return connection must be run full size from the Furnace to a location outside the utility room, basement, attic, or crawl space.

Do NOT install return air through the back of the Furnace cabinet.

Bottom Return Only

NOTE: Minimum return air temperature is 55° F.

NOTE: No sheetmetal screws may be used from 0-4" from the bottom of the unit. Screws will interfere with the air cleaner. See Figure 4.

The following warning complies with State of California law, Proposition 65.

WARNING

Hazardous Gases!

Exposure to fuel substances or by-products of incomplete fuel combustion is believed by the state of California to cause cancer, birth defects, or other reproductive harm.

Carbon monoxide, fire or smoke can cause serious bodily injury, death, and/ or property damage.

A variety of potential sources of carbon monoxide can be found in a building or dwelling such as gas-fired clothes dryers, gas cooking stoves, water heaters, Furnaces and fireplaces. The U.S. Consumer Product Safety Commission recommends that users of gas-burning appliances install carbon monoxide detectors as well as fire and smoke detectors per the manufacturers installation instructions to help alert dwelling occupants of the presence of fire, smoke or unsafe levels of carbon monoxide. These devices should be listed by Underwriters Laboratories, Inc. *Standards for Single and Multiple Station Carbon Monoxide Alarms, UL 2034* or CSA International Standard, *Residential Carbon Monoxide Alarming Devices, CSA 6.19*

NOTE: The manufacturer of your Furnace does NOT test any detectors and makes no representations regarding any brand or type of detector.

Connect duct work to Furnace. See Outline Drawing for supply and return duct size and location. Flexible duct connectors are recommended to connect both supply and return air ducts to the Furnace. If only the front of the Furnace is accessible, it is recommended that both supply and return air plenums are removable.

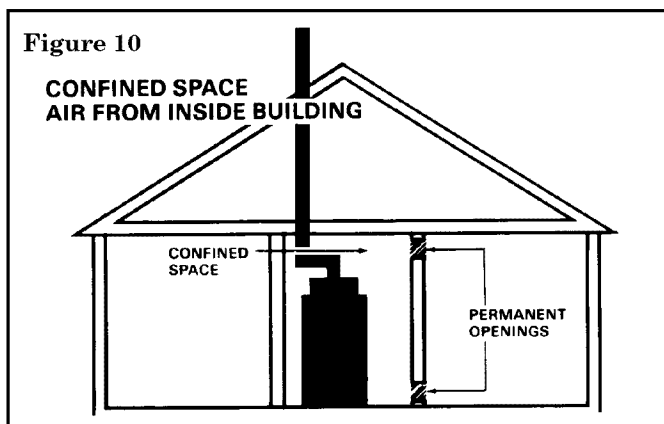
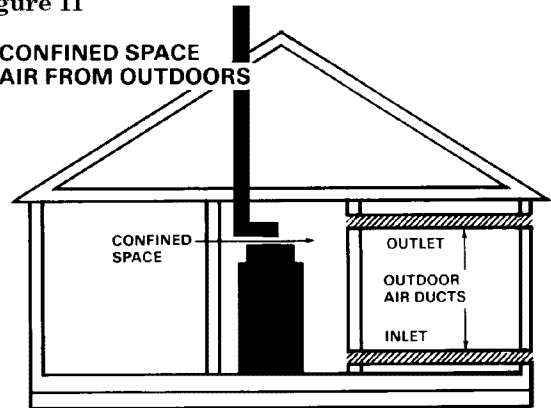
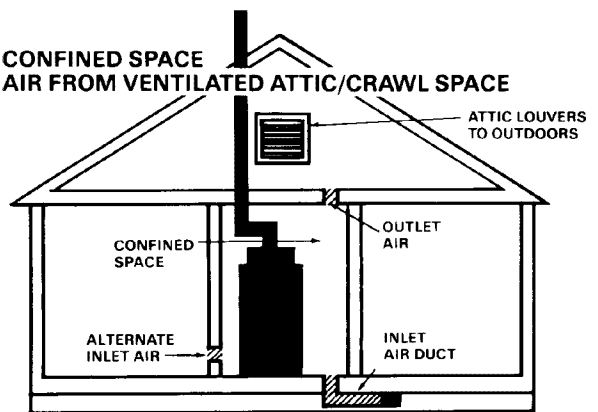

Figure 11

CONFINED SPACE
AIR FROM OUTDOORS



CONFINED SPACE
AIR FROM VENTILATED ATTIC/CRAWL SPACE



CONFINED SPACE
AIR FROM VENTILATED ATTIC

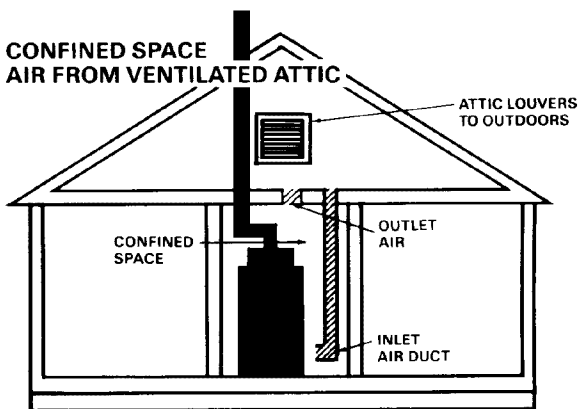

Installer's Guide

GENERAL VENTING INSTRUCTIONS

WARNING

CARBON MONOXIDE POISONING HAZARD

Failure to follow the steps outlined below for each appliance connected to the venting system being placed into operation could result in carbon monoxide poisoning or death.

The following steps shall be followed for each appliance connected to the venting system being placed into operation, while all other appliances connected to the venting system are not in operation:

1. Seal any unused openings in the venting system.
2. Inspect the venting system for proper size and horizontal pitch, as required in the National Fuel Gas Code, ANSI Z223.1/NFPA 54 or the CSA B149.1 *Natural Gas and Propane Installation Code* and these instructions. Determine that there is no blockage or restriction, leakage, corrosion and other deficiencies which could cause an unsafe condition.
3. As far as practical, close all building doors and windows and all doors between the space in which the appliance(s) connected to the venting system are located and other deficiencies which could cause an unsafe condition.
4. Close fireplace dampers.
5. Turn on clothes dryers and any appliance not connected to the venting system. Turn on any exhaust fans, such as range hoods and bathroom exhausts, so they are operating at maximum speed. Do not operate a summer exhaust fan.
6. Follow the lighting instructions. Place the appliance being inspected into operation. Adjust the thermostat so appliance is operating continuously.
7. Test for spillage from draft hood equipped appliances at the draft hood relief opening after 5 minutes of main burner operation. Use the flame of a match or candle.
8. If improper venting is observed during any of the above tests, the venting system must be corrected in accordance with the National Fuel Gas Code, ANSI Z221.1/NFPA 54 and/or CSA B149.1 *Natural Gas and Propane Installation Code*.
9. After it has been determined that each appliance connected to the venting system properly vents where tested as outlined above, return doors, windows, exhaust fans, fireplace dampers and any other gas-fired burning appliance to their previous conditions of use.

VENT PIPING

These Furnaces have been classified as Fan-Assisted Combustion System, Category I Furnaces under the "latest edition" provisions of ANSI Z21.47 and CAN/CGA 2.3 standards. Category I Furnaces operate with a non-positive vent static pressure and with a flue loss of not less than 17 percent.

NOTE: *If desired, a side wall termination can be accomplished through the use of an "add-on" draft inducer. The inducer must be installed according to the inducer manufacturer's instructions. Set the barometric pressure relief to achieve -0.02 inch water column.*

NOTE: *The Furnace shall be connected to a chimney or vent complying with a recognized standard, or a masonry or concrete chimney lined with a lining material acceptable to the authority having jurisdiction.*

WARNING

Furnace venting into an unlined masonry chimney or concrete chimney is prohibited. Failure to follow this warning could result in property damage, personal injury, or death.

VENTING INTO A MASONRY CHIMNEY

If the chimney is oversized, the liner is inadequate, or flue-gas condensation is a problem in your area, consider using the chimney as a pathway or chase for type "B" vent or flexible vent liner. If flexible liner material is used, size the vent using the "B" vent tables, then reduce the maximum capacity by 20% (multiply 0.80 times the maximum capacity). Masonry Chimney Kit BAYVENT800B may be used with these Furnaces (**Upflow model furnaces only**) to allow venting into a masonry chimney. Refer to the BAYVENT800B Installer's Guide for application requirements.

Internal Masonry Chimneys

Venting of fan assisted appliances into a lined, internal masonry chimney is allowed only if it is common vented with at least one natural draft appliance; **OR**, if the chimney is lined with type "B", double wall vent or suitable flexible liner material (See Table 4).

WARNING

The chimney liner must be thoroughly inspected to insure no cracks or other potential areas for flue gas leaks are present in the liner. Liner leaks will result in early deterioration of the chimney.

Failure to follow this warning could result in carbon monoxide poisoning or death.

NOTE: *The following section does not apply if BAYVENT800B (Masonry Chimney Vent Kit) is used. All instructions with the kit must be followed.*

**TABLE 4
MASONRY CHIMNEY VENTING**

Type Furnace	Tile Lined Chimney		Chimney Lining	
	Internal	External	"B" Vent	Flexible Metal Liner
Single Fan Assist	No	No	Yes	Yes*
Fan Assist + Fan Assist	No	No	Yes	Yes*
Fan Assist + Natural	Yes	No	Yes	Yes*

* Flexible chimney liner size is determined by using the type "B" vent size for the available BTUH input, then reducing the maximum capacity by 20% (multiply maximum capacity times 0.80). The minimum capacity is the same as shown in the "B" vent tables.

External Masonry Chimney

Venting of fan assisted appliances into external chimneys (one or more walls exposed to outdoor temperatures), requires the chimney be lined with type "B", double wall vent or suitable flexible chimney liner material. This applies in all combinations of common venting as well as for fan assisted appliances vented alone.

The following installation practices are recommended to minimize corrosion caused by condensation of flue products in the Furnace and flue gas system.

⚠ WARNING

CARBON MONOXIDE POISONING HAZARD

Failure to follow the installation instructions for the venting system being placed into operation could result in carbon monoxide poisoning or death.

1. Avoid an excessive number of bends.
2. Horizontal runs should pitch upward at least 1/4" per foot.
3. Horizontal runs should be as short as possible.
4. All vent pipe or connectors should be securely supported and must be inserted into, but not beyond the inside wall at the chimney vent.
5. When vent connections must pass through walls or partitions of combustible material, a thimble must be used and installed according to local codes.
6. Vent pipe through the roof should be extended to a height determined by National Fuel Gas Code or local codes. See Figure 12 and Table 5. It should be capped properly to prevent rain water from entering the vent. Roof exit should be waterproofed.
7. Use type "B" double wall vent when vent pipe is routed through cool spaces (below 60° F.).
8. Where long periods of airflow are desired for comfort, use long fan cycles instead of continuous airflow.
9. Apply other good venting practices as stated in the venting section of the National Fuel Gas Code ANSI Z223.1 "latest edition".
10. **Vent connectors serving appliance vented by natural draft or non-positive pressure shall not be connected into any portion of a mechanized draft system operating under positive pressure.**

11. Horizontal pipe runs must be supported by hangers, straps or other suitable material in intervals at a minimum of every 3 feet of pipe.
12. A Furnace shall not be connected to a chimney or flue serving a separate appliance designed to burn solid fuel.
13. The flow area of the largest section of vertical vent or chimney shall not exceed 7 times the smallest listed appliance categorized vent area, flue collar area, or draft hood outlet area unless designed in accordance with approved engineering methods.

$$\text{Maximum Vent or Tile Lined Chimney Flow Area} = \frac{\pi(D^*)^2}{4} \times 7$$

*Drafthood outlet diameter, flue collar diameter, or listed appliance categorized vent diameter.

⚠ WARNING

The cabinet must have an uninterrupted or unbroken ground according to National Electrical Code, ANSI/NFPA 70 - "latest edition" and Canadian Electrical Code, CSA C22.1 or local codes to minimize personal injury if an electrical fault should occur.

Failure to follow this warning could result in an electrical shock, fire, injury, or death.

⚠ CAUTION

The Integrated Furnace Control is polarity sensitive. The hot leg of the 115 VAC power must be connected to the BLACK field lead.

⚠ WARNING

To prevent injury or death due to electrical shock or contact with moving parts, lock unit disconnect switch in the open position before servicing the unit. Failure to follow this warning could result in electrical shock, personal injury, or death.

TABLE 5

GAS VENT TERMINATION	
ROOF PITCH	MINIMUM HEIGHT
FLAT TO 7/12	1.0 FEET *
OVER 7/12 TO 8/12	1.5 FEET
OVER 8/12 TO 9/12	2.0 FEET
OVER 9/12 TO 10/12	2.5 FEET
OVER 10/12 TO 11/12	3.25 FEET
OVER 11/12 TO 12/12	4.0 FEET
OVER 12/12 TO 14/12	5.0 FEET
OVER 14/12 TO 16/12	6.0 FEET
OVER 16/12 TO 18/12	7.0 FEET
OVER 18/12 TO 20/12	7.5 FEET
OVER 20/12 TO 22/12	8.0 FEET

* THIS REQUIREMENT COVERS MOST INSTALLATIONS

Installer's Guide

FIGURE 12

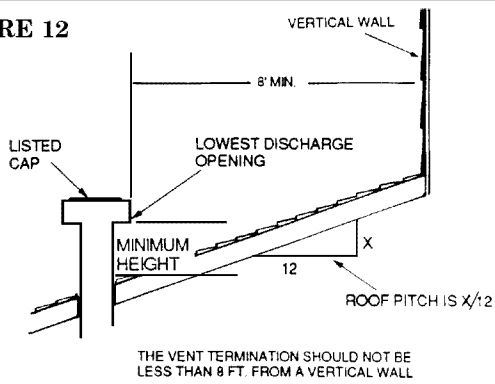

FIELD WIRING DIAGRAM FOR VARIABLE SPEED 2 STAGE FURNACE 1 STAGE HEATING USING A 1 STAGE HEATING THERMOSTAT NO COOLING

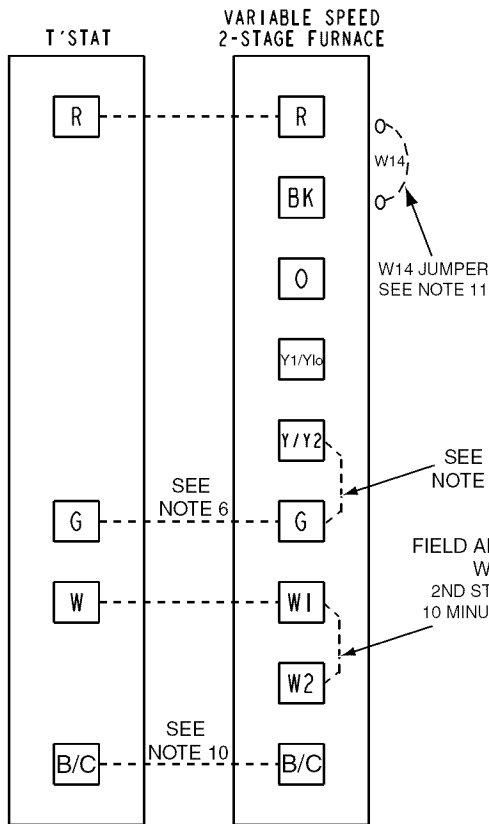

1. Be sure power agrees with equipment nameplates.
2. Low voltage (24 volt wiring) to be No. 18 A.W.G. min.
3. Grounding of equipment must comply with local codes.
4. Set thermostat heat anticipator per unit wiring diagram.
5. These leads provide 115V. power for connection of humidifier MAX. load 1.0 amp.
6. When a single stage heating thermostat without fan switch is used, no wiring on "G" terminal is used.
7. W1 and W2 must be jumpered together for proper operation. Second stage heat will begin 10 minutes after first stage.
8. Set dip switches with power off per installation instructions to set airflow and indoor fan off delays.
9. Continuous fan airflow can be increased by adding this jumper.
10. This wire is only for thermostats requiring connection to transformer common terminal.
11. Optional humidistat is to be connected between R and BK. Factory installed jumper R to BK on the circuit board must be cut if optional humidistat is used. The jumper must also be cut when applying an airflow command signal to the BK input such as with the variable speed single-zone and multi-zone system controllers. On single speed cooling only/non-heat pump systems, jumper Y to O for proper operation of the delay profiles and the humidistat. For two compressor or two speed systems, jumper YLo to O.

FIELD ADDED JUMPER
W1 TO W2.
2ND STAGE WILL FIRE
10 MINUTES AFTER 1ST.

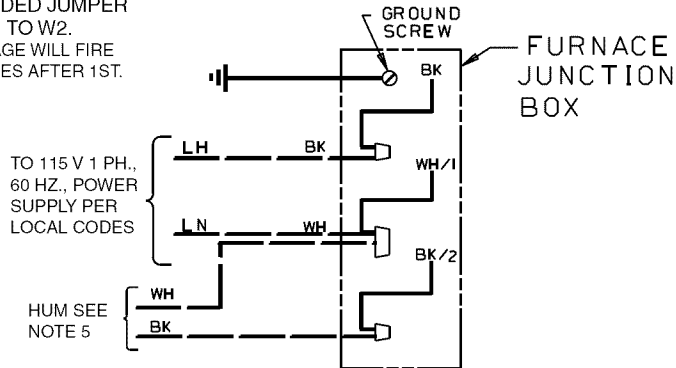

INTER-COMPONENT WIRING

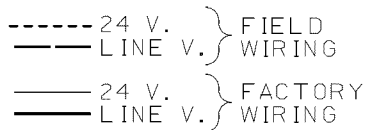

From Dwg. B342027 Rev. 0

FIELD WIRING DIAGRAM FOR VARIABLE SPEED 2 STAGE FURNACE 2 STAGE HEATING USING A 2 STAGE HEATING THERMOSTAT NO COOLING

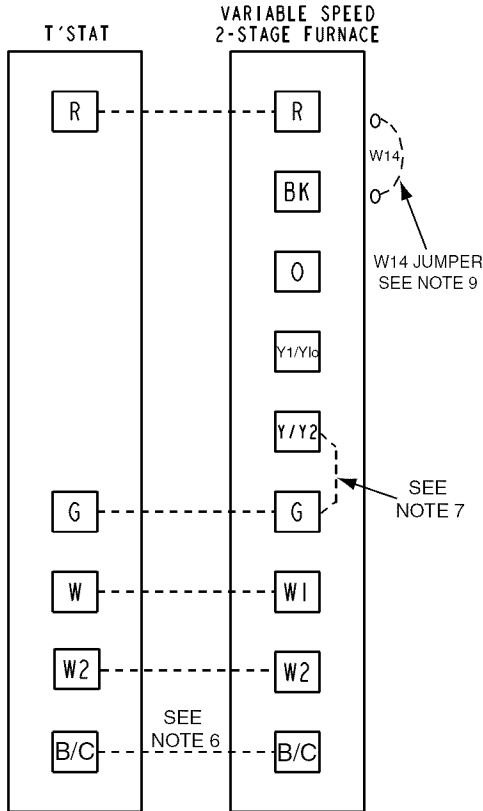

INTER-COMPONENT WIRING

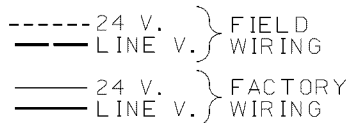

1. Be sure power agrees with equipment nameplates.
2. Low voltage (24 volt wiring) to be No. 18 A.W.G. min.
3. Grounding of equipment must comply with local codes.
4. Set thermostat heat anticipator per unit wiring diagram.
5. These leads provide 115V. power for connection of humidifier MAX. load 1.0 amp.
6. This wire is only for thermostats requiring connection to transformer common terminal.
7. Continuous fan airflow can be increased by adding this jumper.
8. Set dip switches with power off per installation instructions to set airflow and indoor fan off delays.
9. Optional humidistat is to be connected between R and BK. Factory installed jumper R to BK on the circuit board must be cut if optional humidistat is used. The jumper must also be cut when applying an airflow command signal to the BK input such as with the variable speed single-zone and multi-zone system controllers. On single speed cooling only/non-heat pump systems, jumper Y to O for proper operation of the delay profiles and the humidistat. For two compressor or two speed systems, jumper YLo to O.

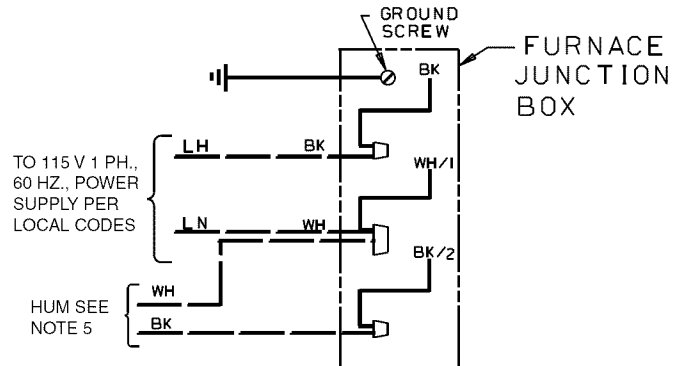

From Dwg. B342025 Rev. 0

Installer's Guide

FIELD WIRING DIAGRAM FOR VARIABLE SPEED 2 STAGE FURNACE 1 STAGE HEATING, 1 STAGE COOLING USING A 1 STAGE HEATING, 1 STAGE COOLING THERMOSTAT (OUTDOOR SECTION WITHOUT TRANSFORMER)

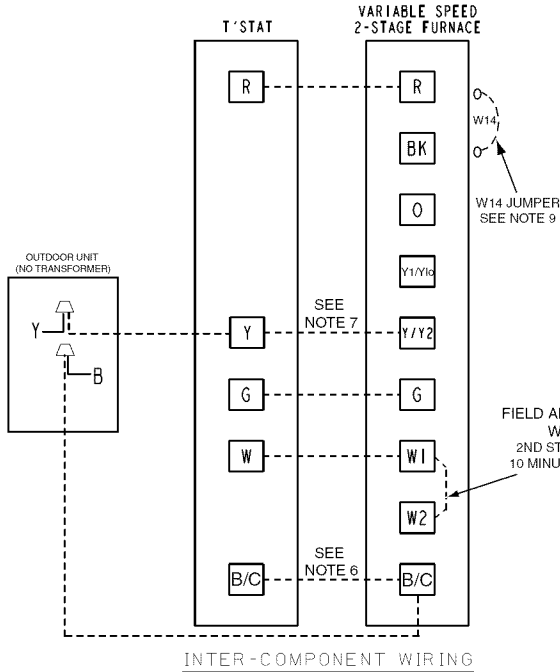

- NOTES:**
1. BE SURE POWER AGREES WITH EQUIPMENT NAMEPLATE(S)
 2. LOW VOLTAGE(24 V. WIRING) TO BE NO. 18 A.W.G. MIN.
 3. GROUNDING OF EQUIPMENT MUST COMPLY WITH LOCAL CODES.
 4. SET THERMOSTAT HEAT ANTICIPATOR PER UNIT WIRING DIAGRAM.
 5. THESE LEADS PROVIDE 115 V. POWER FOR CONNECTION OF THE HUMIDIFIER MAX. LOAD 1.0 AMPS EACH.
 6. THIS WIRE IS ONLY FOR THERMOSTATS REQUIRING CONNECTION TO TRANSFORMER COMMON TERMINAL.
 7. THE "Y" TERMINAL FROM THE THERMOSTAT MUST BE WIRED TO THE "Y" TERMINAL OF THE FURNACE CONTROL FOR PROPER BLOWER OPERATION DURING COOLING.
 8. SET DIP SWITCHES WITH POWER OFF PER INSTALLATION INSTRUCTIONS TO SET AIRFLOW AND INDOOR FAN OFF DELAYS.
 9. OPTIONAL HUMIDISTAT IS TO BE CONNECTED BETWEEN R AND BK. FACTORY INSTALLED JUMPER R TO BK ON THE CIRCUIT BOARD MUST BE CUT IF OPTIONAL HUMIDISTAT IS USED. THE JUMPER MUST ALSO BE CUT WHEN APPLYING AN AIRFLOW COMMAND SIGNAL TO THE BK INPUT SUCH AS WITH THE VARIABLE SPEED, SINGLE-ZONE AND MULTI-ZONE SYSTEM CONTROLLERS. ON SINGLE SPEED COOLING ONLY/NON-HEAT PUMP SYSTEMS, JUMPER Y TO 0 FOR PROPER OPERATION OF THE DELAY PROFILES AND THE HUMIDISTAT. FOR TWO COMPRESSOR OR TWO SPEED SYSTEMS, JUMPER YLO TO 0.

FIELD ADDED JUMPER
W1 TO W2.
2ND STAGE WILL FIRE
10 MINUTES AFTER 1ST.

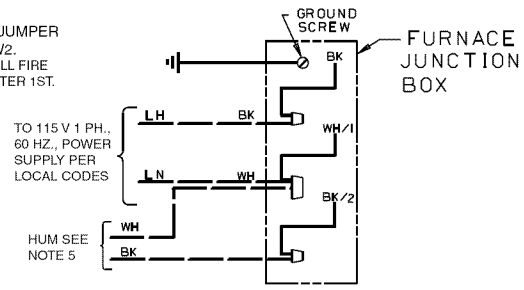

INTER-COMPONENT WIRING

--- 24 V. } FIELD WIRING
 --- LINE V. }
 --- 24 V. } FACTORY WIRING
 --- LINE V. }

From drawing B342022 Rv 0

FIELD WIRING DIAGRAM FOR VARIABLE SPEED 2 STAGE FURNACE
 2 STAGE HEATING, 1 STAGE COOLING
 USING A 2 STAGE HEATING, 1 STAGE COOLING THERMOSTAT
 (OUTDOOR SECTION WITHOUT TRANSFORMER)

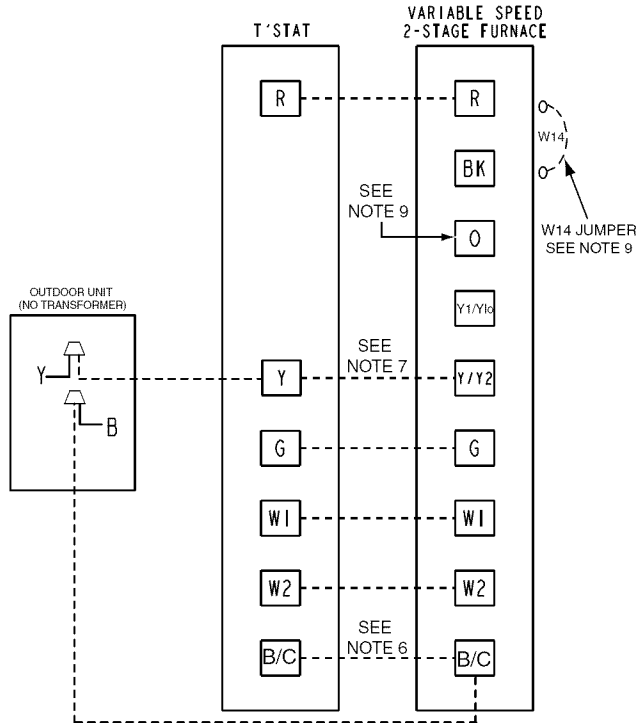

- NOTE:
- 1.) BE SURE POWER AGREES WITH EQUIPMENT NAMEPLATE(S).
 - 2.) LOW VOLTAGE (24V. WIRING) TO BE NO. 18AWG MIN.
 - 3.) GROUNDING OF EQUIPMENT MUST COMPLY WITH LOCAL BUILDING CODES.
 - 4.) SET THERMOSTAT HEAT ANTICIPATOR PER UNIT WIRING DIAGRAM.
 - 5.) THESE LEADS PROVIDE 115V. POWER FOR CONNECTION OF THE HUMIDIFIER. MAX. LOAD 1.0 AMPS EACH.
 - 6.) THIS WIRE IS ONLY FOR THERMOSTATS REQUIRING CONNECTION TO TRANSFORMER COMMON TERMINAL.
 - 7.) THE "Y" TERMINAL FROM THE THERMOSTAT MUST BE WIRED TO THE "Y" TERMINAL OF THE FURNACE CONTROL FOR PROPER BLOWER OPERATION DURING COOLING.
 - 8.) SET DIP SWITCHES WITH POWER OFF PER INSTALLATION INSTRUCTIONS TO SET AIRFLOW AND INDOOR FAN OFF DELAYS.
 - 9.) OPTIONAL HUMIDISTAT IS TO BE CONNECTED BETWEEN "R" AND "BK". FACTORY INSTALLED JUMPER "R" TO "BK" ON THE CIRCUIT BOARD MUST BE CUT IF OPTIONAL HUMIDISTAT IS USED. THE JUMPER MUST ALSO BE CUT WHEN APPLYING AN AIRFLOW COMMAND SIGNAL TO THE "BK" INPUT SUCH AS WITH THE VARIABLE SPEED SINGLE-ZONE AND MULTI-ZONE SYSTEM CONTROLLERS. ON SINGLE SPEED COOLING ONLY / NON-HEAT PUMP SYSTEMS, JUMPER "Y" TO "O" FOR PROPER OPERATION OF THE DELAY PROFILES AND THE HUMIDISTAT. FOR TWO COMPRESSOR OR TWO SPEED SYSTEMS, JUMPER "YLO" TO "O".

INTER-COMPONENT WIRING

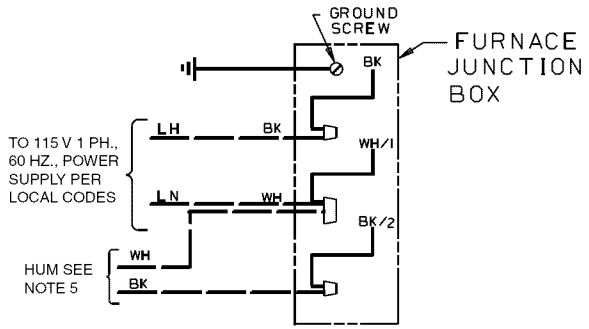
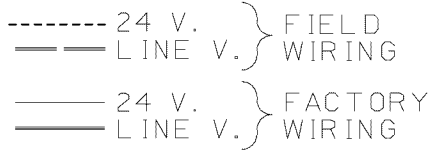

From Dwg. B342020 Rev. 0

Installer's Guide

FIELD WIRING DIAGRAM FOR VARIABLE SPEED 2 STAGE FURNACE 2 STAGE HEATING, 2 STAGE COOLING (OUTDOOR SECTION WITHOUT TRANSFORMER)

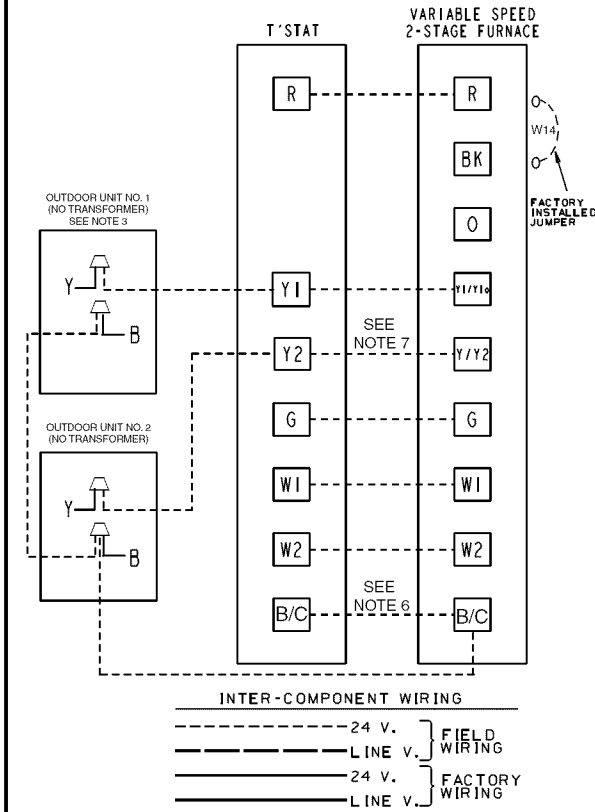

NOTES:

1. BE SURE POWER AGREES WITH EQUIPMENT NAMEPLATE(S)
2. LOW VOLTAGE (24 V. WIRING) TO BE NO. 18 A.W.G. MIN.
3. GROUNDING OF EQUIPMENT MUST COMPLY WITH LOCAL CODES.
4. SET THERMOSTAT HEAT ANTICIPATOR PER UNIT WIRING DIAGRAM.
5. THESE LEADS PROVIDE 115 V. POWER FOR CONNECTION OF THE HUMIDIFIER MAX. LOAD 1.0 AMPS EACH.
6. THIS WIRE IS ONLY FOR THERMOSTATS REQUIRING CONNECTION TO TRANSFORMER COMMON TERMINAL.
7. THE "Y2" TERMINAL FROM THE THERMOSTAT MUST BE WIRED TO THE "Y" TERMINAL OF THE FURNACE CONTROL FOR PROPER BLOWER OPERATION DURING COOLING.
8. SET DIP SWITCHES WITH POWER OFF PER INSTALLATION INSTRUCTIONS TO SET AIRFLOW AND INDOOR FAN OFF DELAYS.
9. OPTIONAL HUMIDISTAT IS TO BE CONNECTED BETWEEN R AND BK. FACTORY INSTALLED JUMPER R TO BK ON THE CIRCUIT BOARD MUST BE CUT IF OPTIONAL HUMIDISTAT IS USED. THE JUMPER MUST ALSO BE CUT WHEN APPLYING AN AIRFLOW COMMAND SIGNAL TO THE BK INPUT SUCH AS WITH THE VARIABLE SPEED SINGLE-ZONE AND MULTI-ZONE SYSTEM CONTROLLERS, ON SINGLE SPEED COOLING ONLY/NON-HEAT PUMP SYSTEMS. JUMPER Y TO O FOR PROPER OPERATION OF THE DELAY PROFILES AND THE HUMIDISTAT. FOR TWO COMPRESSOR OR TWO SPEED SYSTEMS, JUMPER YLO TO O.

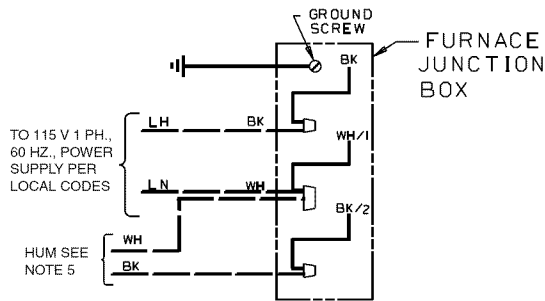

From Dwg. B342018 Rev. 0

HUMIDISTAT HOOKUP

If an optional Humidistat is to be connected between "R" and "BK", the factory installed jumper between "R" and "BK" on the circuit board must be cut. If an optional Humidistat is used, the jumper must also be cut when applying an airflow command signal to the "BK" input such as with the variable speed single-zone and multi-zone system controller. On single speed cooling only/ non-heat pump systems, jumper "Y" to "O" for proper operation of the delay profiles and the Humidistat. For two compressor or two speed systems, jumper "Ylo" to "O".

FIGURE 13

The factory installed jumper between "R" and "BK" on the circuit board must be cut if an optional Humidistat is installed.

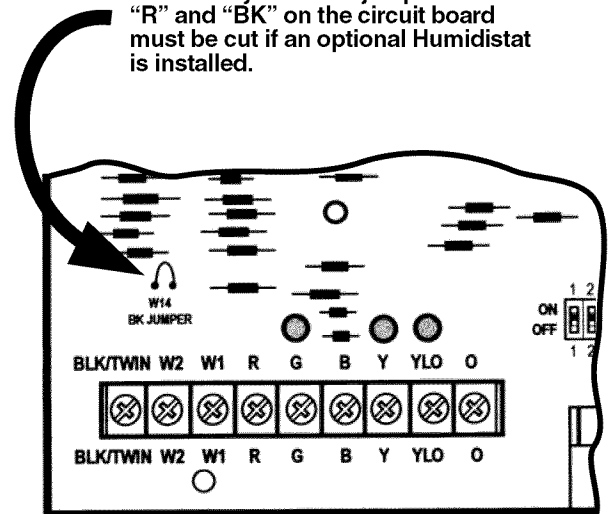

ELECTRICAL CONNECTIONS

Make wiring connections to the unit as indicated on enclosed wiring diagram. As with all gas appliances using electrical power, this Furnace shall be connected into a permanently live electric circuit. It is recommended that Furnace be provided with a separate "circuit protection device" electric circuit. The Furnace must be electrically grounded in accordance with local codes or in the absence of local codes with the National Electrical Code, ANSI/NFPA 70 or CSA C22.1 Electrical Code, if an external electrical source is utilized. **The integrated Furnace control is polarity sensitive.** The hot leg of the 120V power supply must be connected to the black power lead as indicated on the wiring diagram. Provision for hooking up a humidifier is provided on the integrated control.

Refer to the SERVICE FACTS literature and unit wiring diagram attached to furnace.

GAS PIPING

⚠ WARNING

DO NOT USE SEMI-RIGID METALLIC GAS CONNECTORS (FLEXIBLE GAS LINES) WITHIN THE FURNACE CABINET. FAILURE TO FOLLOW THIS WARNING COULD RESULT IN PROPERTY DAMAGE, PERSONAL INJURY OR DEATH.

The following warning complies with State of California law, Proposition 65.

⚠ WARNING

Hazardous Gases!

Exposure to fuel substances or by-products of incomplete fuel combustion is believed by the state of California to cause cancer, birth defects, or other reproductive harm.

⚠ WARNING

EXPLOSION HAZARD! PROPANE GAS IS HEAVIER THAN AIR AND MAY COLLECT IN ANY LOW AREAS OR CONFINED SPACES. IF THE GAS FURNACE IS INSTALLED IN A BASEMENT, AN EXCAVATED AREA OR A CONFINED SPACE, IT IS STRONGLY RECOMMENDED TO CONTACT A GAS SUPPLIER TO INSTALL A GAS DETECTING WARNING DEVICE IN CASE OF A GAS LEAK.

NOTE: The manufacturer of your furnace does not test any detectors and makes no representations regarding any brand or type of detector.

⚠ WARNING

EXPLOSION HAZARD! ODORANT FADE MAY MAKE THE GAS UNDETECTABLE EXCEPT WITH A WARNING DEVICE. IF THE GAS FURNACE IS INSTALLED IN A BASEMENT, AN EXCAVATED AREA OR A CONFINED SPACE, IT IS STRONGLY RECOMMENDED TO CONTACT A GAS SUPPLIER TO INSTALL A GAS DETECTING WARNING DEVICE IN CASE OF A GAS LEAK.

NOTE: The manufacturer of your furnace does NOT test any detectors and makes no representations regarding any brand or type of detector.

TABLE 6
NATURAL GAS ONLY

TABLE OF CUBIC FEET PER HOUR OF GAS FOR VARIOUS PIPE SIZES AND LENGTHS							
PIPE SIZE	LENGTH OF PIPE						
	10	20	30	40	50	60	70
1/2	132	92	73	63	56	50	46
3/4	278	190	152	130	115	105	96
1	520	350	285	245	215	195	180
1-1/4	1050	730	590	520	440	400	370

This table is based on pressure drop of 0.3 inch W.C. and 0.6 SP.GR. gas

TABLE 7
ORIFICE SIZES

INPUT RATING BTUH	NUMBER OF BURNERS	MAIN BURNER ORIFICE DRILL SIZE	
		NAT. GAS	LP GAS
60,000	3	45	56
80,000	4	45	56
100,000	5	45	56
120,000	6	45	56

⚠ CAUTION

Use a backup wrench on the Gas Valve when installing gas piping to prevent damage to the Gas Valve and Manifold Assembly.

The installation of piping shall be in accordance with piping codes and the regulations of the local gas company. Pipe joint compound must be resistant to the chemical reaction with liquefied petroleum gases.

Refer to piping Table 6, for delivery sizes. Connect gas supply to the unit, using a ground joint union and a manual shut-off Valve as shown in Figures 14 and 15. National codes require a condensation drip leg to be installed ahead of the controls as shown in Figures 14 and 15.

The Furnace and its individual shut-off valve must be disconnected from the gas supply piping system during any pressure testing of that system at test pressures in excess of 1/2 psig (3.5 kPa).

Installer's Guide

The Furnace must be isolated from the gas supply piping by closing its individual manual shut-off Valve during any pressure testing of the gas supply piping system at test pressures equal to or less than 1/2 psig (3.5 kPa).

NOTE: Maximum pressure to the Gas Valve for natural gas is 13.8" W.C. Minimum pressure is 5.0" W.C. Maximum pressure to the Gas Valve for propane is 13.8" W.C. Minimum pressure is 11.0" W.C.

All gas fittings must be checked for leaks using a soapy solution before lighting the Furnace. **DO NOT CHECK WITH AN OPEN FLAME!**

Figure 14 LEFT SIDE PIPING (STANDARD)

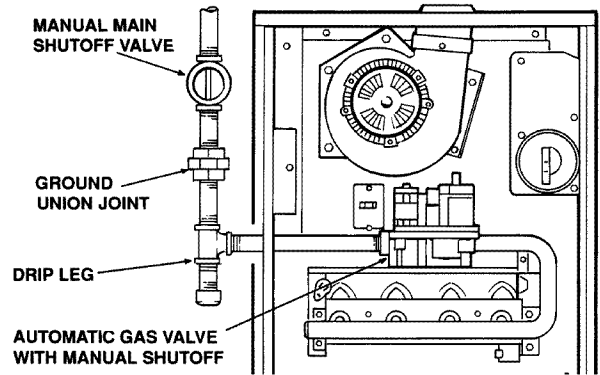

RIGHT SIDE PIPING (OPTIONAL)

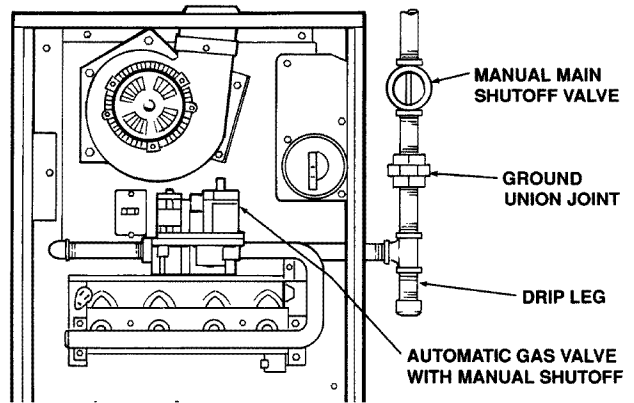

TOP VIEW OF RIGHT SIDE PIPING

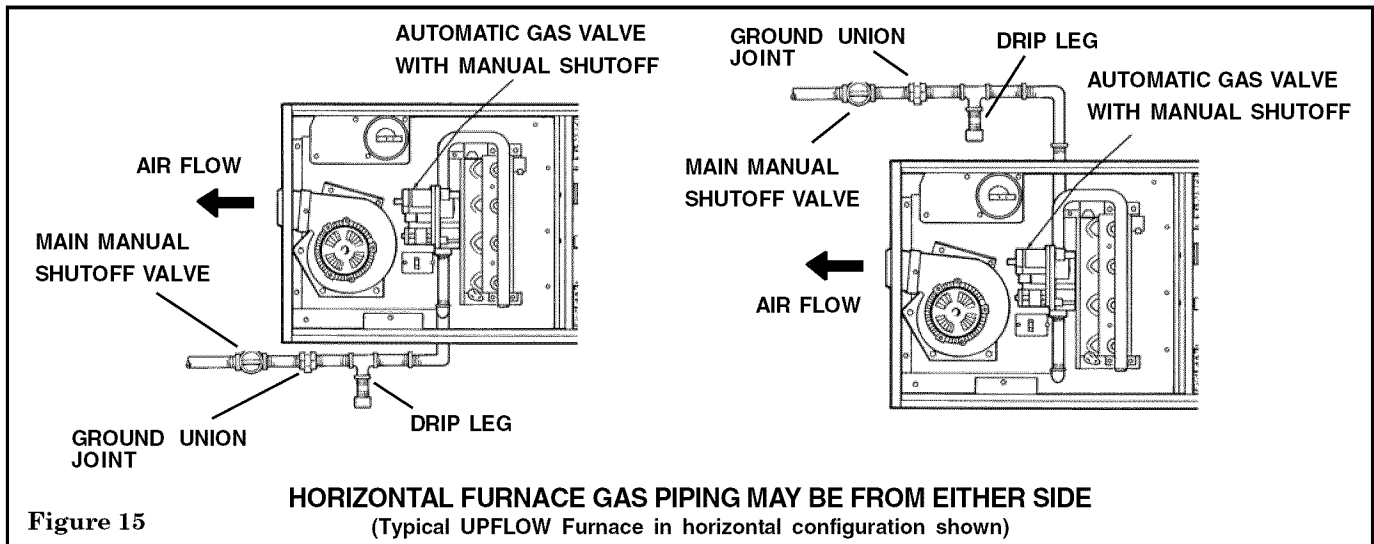
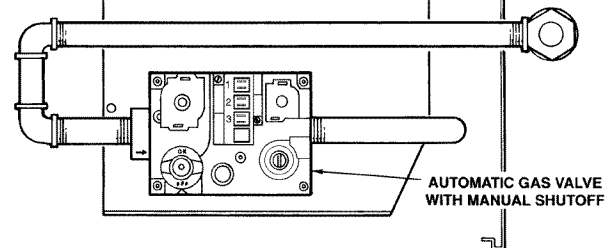

HORIZONTAL FURNACE GAS PIPING MAY BE FROM EITHER SIDE
(Typical UPFLOW Furnace in horizontal configuration shown)

COMBUSTION AND INPUT CHECK (See also High Altitude Derate)

⚠ WARNING

Replace and/ or tighten all plugs removed or loosened when adjusting gas pressure. Leak check the fittings before placing the Furnace into regular service. Failure to follow this warning could result in fire, explosion, property damage, or death.

1. Make sure all gas appliances are off except the Furnace.
2. Clock the gas meter with the Furnace operating (determine the dial rating of the meter) for one revolution.
3. Match the "Sec" column in the gas flow (in cfh) Table 8 with the time clocked.
4. Read the "Flow" column opposite the number of seconds clocked.
5. Use the following factors if necessary:
 For 1 Cu. Ft. Dial Gas Flow CFH = Chart Flow Reading $\div 2$
 For 1/2 Cu Ft. Dial Gas Flow CFH = Chart Flow Reading $\div 4$
 For 5 Cu. Ft. Dial Gas Flow CFH =
 $10 \times \text{Chart Flow Reading} \div 4$
6. Multiply the final figure by the heating value of the gas obtained from the utility company and compare to the nameplate rating. This must not exceed the nameplate rating.
7. Changes can be made by adjusting the Manifold Pressure (See Table 9), or changing orifices (orifice change may not always be required). To adjust the Manifold Pressure:
 - a. Turn off all electrical power to the system.
 - b. Attach a Manifold Pressure gauge to the outlet pressure tap marked "OUT PRESS TAP" on White-Rodgers gas valve model 36G. (see Figure 17 for White-Rodgers gas valve model 36G). Attach flexible tubing and a Manometer to the barbed fitting. For the Gas Valve model 36G, do not remove the pressure tap test screw. Loosen the pressure tap test screw one turn and install flexible tubing and a Manometer directly onto the outlet pressure boss.
 - c. The other side of the Manifold Pressure Gauge must be referenced to the Burner Box as shown in Figure 16.
 - d. Turn on system power and energize Valve.
 - e. For the White-Rodgers Gas Valve model 36G:
 1. Adjust low fire by removing the low adjustment regulator cover screw (See Figure 17).
 2. To increase outlet pressure, turn the regulator adjust screw clockwise. To decrease outlet pressure, turn the regulator adjust screw counterclockwise. Adjust regulator until pressure shown on Manometer matches the pressure specified in Table 9.
 3. Replace and tighten the regulator cover screw securely.
 4. Cycle the Valve several times to verify regulator setting.
 5. Adjust high fire by removing the high adjustment regulator cover screw (See Figure 17).

Figure 16

CORRECT METHOD OF CHECKING DIRECT VENT MANIFOLD PRESSURE WITH BURNER BOX REFERENCED

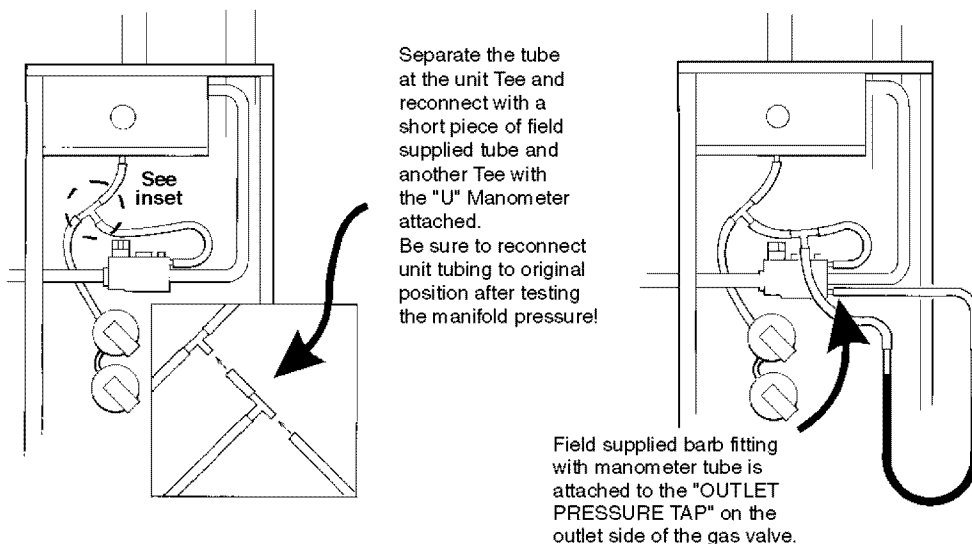

⚠ CAUTION: Return all tubing, caps, and/or plugs to original positions when pressure checks are completed.

Installer's Guide

6. To increase outlet pressure, turn the regulator adjust screw clockwise. To decrease outlet pressure, turn the regulator adjust screw counterclockwise. The final Manifold Pressure setting shall be as specified in Table 9 with an input of no more than nameplate rating and no less than 93% of the nameplate rating, unless the unit is derated for high altitude.
7. Replace high adjustment regulator cover screw and tighten securely.
8. Cycle the Valve several times to verify regulator setting.
- f. Turn off all electrical power to the system.
- g. Remove the Manometer and flexible tubing. Remove the barbed fitting and replace the plug or tighten the pressure test screw.
- h. Turn on electrical power to the system and energize valve.
- i. Using a leak detection solution or soap suds, check for leaks at plug or pressure boss screw.

NOTE: The Manifold Pressure must be referenced to the Burner Box. The Burner Box pressure tap equalizes the Gas Valve pressure regulator. Manifold Pressure is checked by installing a tee (field supplied) in the tubing, between the tee coming from the Burner Box tube and the Gas Valve, in addition to the regular Gas Valve pressure tap on the outlet side of the Gas Valve. See Figure 16.

Table 7 lists the main burner orifices used with the Furnace. If a change of orifices is required to correct the Furnace input rating refer to Table 10.

TABLE 8

GAS FLOW IN CUBIC FEET PER HOUR							
2 CUBIC FOOT DIAL							
SEC.	FLOW	SEC.	FLOW	SEC.	FLOW	SEC.	FLOW
8	900	29	248	50	144	82	88
9	800	30	240	51	141	84	86
10	720	31	232	52	138	86	84
11	655	32	225	53	136	88	82
12	600	33	218	54	133	90	80
13	555	34	212	55	131	92	78
14	514	35	206	56	129	94	76
15	480	36	200	57	126	96	75
16	450	37	195	58	124	98	73
17	424	38	189	59	122	100	72
18	400	39	185	60	120	104	69
19	379	40	180	62	116	108	67
20	360	41	176	64	112	112	64
21	343	42	172	66	109	116	62
22	327	43	167	68	106	120	60
23	313	44	164	70	103	124	58
24	300	45	160	72	100	128	56
25	288	46	157	74	97	132	54
26	277	47	153	76	95	136	53
27	267	48	150	78	92	140	51
28	257	49	147	80	90	144	50

TABLE 9

FINAL MANIFOLD PRESSURE SETTINGS (inches w.c.)		
FUEL	2nd Stage Max.	1st Stage Max.
NATURAL GAS	3.5" W.C.	1.7" W.C.
LP GAS	10.5" W.C.	6.0" W.C.

REINSTALLATION OF THE BURNER BOX COVER

Figure 18 shows the correct way to reinstall the Burner Box cover if adjustment or replacement of the flame sensor, hot surface igniter, or main burner orifices have required removal of the cover.

HIGH ALTITUDE DERATE

Input ratings (BTUH) of these Furnaces are based on sea level operation and should not be changed at elevations up to 2,000 ft.

If the installation is 2,000 ft. or above, the Furnace input rate (BTUH) shall be reduced 4% for each 1,000 ft. above sea level.

Installation of this furnace at altitudes above 2,000 ft. (610m) shall be in accordance of local codes, the *National Fuel Gas Code, ANSI Z223.1/ NFPA 54* or *National Standard of Canada, Natural Gas and Propane Installation Code, CSA 149.1*. Installation of this furnace at altitudes above 2,000 ft. (610m) shall be made in accordance with the listed high Altitude Conversion Kit available with this furnace.

The Furnace input rate shall be checked by clocking the gas flow rate (CFH) and multiplying by the heating value obtained from the local utility supplier for the gas being delivered at the installed altitude. Input rate changes can be made by adjusting the Manifold Pressure (min 3.0 - max 3.7 in. W.C. - Natural Gas) or changing orifices (orifice change may not always be required).

If the desired input rate can not be achieved with a change in Manifold Pressure, then the orifices must be changed. LP installations will require an orifice change.

IMPORTANT:

Reinstall the propane orifices to the same depth as the orifices supplied with the equipment.

See Table 11 for help in selecting orifices if orifice change is required. Furnace input rate and temperature rise should be checked again after changing orifices to confirm the proper rate for the altitude.

An optional high altitude kit is available for installations above 5000 feet. Installations above 12,000 feet are not allowed.

TABLE 10
PART NUMBERS FOR REPLACEMENT ORIFICES

DRILL SIZE	PART NUMBER	DRILL SIZE	PART NUMBER
44	ORF00501	54	ORF00555
45	ORF00644	55	ORF00693
46	ORF00909	56	ORF00907
47	ORF00910	57	ORF00908
48	ORF01099	58	ORF01338
49	ORF00503	59	ORF01339
50	ORF00493		

Turn the main Gas Valve toggle switch (See Figures 17) within the unit to the "OFF" position. Turn the external gas valve to "ON". Purge the air from the gas lines. After purging, check all gas connections for leaks with a soapy solution -- **DO NOT CHECK WITH AN OPEN FLAME**. Allow 5 minutes for any gas that might have escaped to dissipate.

LP Gas being heavier than air may require forced ventilation. Turn the toggle switch on the Gas Valve in the unit to the "ON" position.

LIGHTING INSTRUCTIONS

⚠ WARNING

DO NOT ATTEMPT TO MANUALLY LIGHT THE BURNER. FAILURE TO FOLLOW THIS WARNING COULD RESULT IN PROPERTY DAMAGE, PERSONAL INJURY OR DEATH.

TABLE 11

Orifice Twist Drill Size If Installed At Sea Level	ALTITUDE ABOVE SEA LEVEL and Orifice Required At Other Elevations									
	2000	3000	4000	5000	6000	7000	8000	9000	10000	
42	42	43	43	43	44	44	45	46	47	
43	44	44	44	45	45	46	47	47	48	
44	45	45	45	46	47	47	48	48	50	
45	46	47	47	47	48	48	49	49	50	
46	47	47	47	48	48	49	49	50	51	
47	48	48	49	49	49	50	50	51	52	
54	54	55	55	55	55	55	56	56	56	
55	55	55	55	56	56	56	56	56	57	
56	56	56	57	57	57	58	59	59	60	
57	58	59	59	60	60	61	62	63	63	
58	59	60	60	61	62	62	63	63	64	

From National Fuel Gas Code - Table F-4

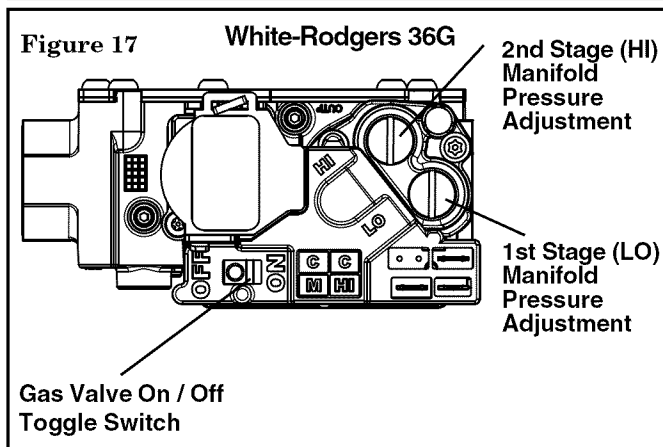

START-UP AND ADJUSTMENT

PRELIMINARY INSPECTIONS

⚠ WARNING

Disconnect power to the unit before removing the blower door. Allow a minimum of 15 seconds for IFC power supply to discharge to 0 volts.

Failure to follow this warning could result in property damage, personal injury or death.

With gas and electrical power "OFF"

1. Duct connections are properly sealed.
2. Air cleaner and filters(if applicable) are in place.
3. Venting is properly assembled.
4. Blower door is in place.

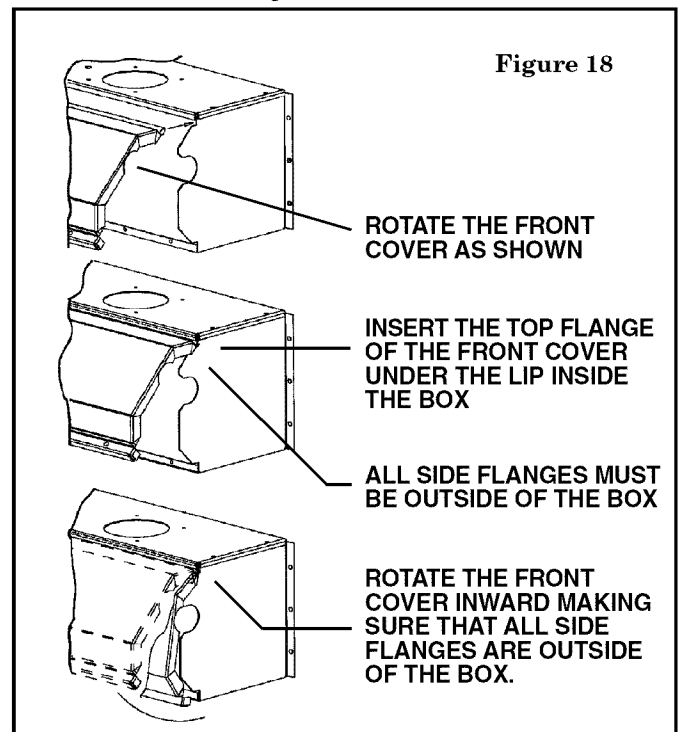

Figure 18

⚠ CAUTION

If this is done during the cold weather months, provisions must be taken to prevent freeze-up of all water pipes and water receptacles.

Lighting instructions appear on each unit. Each installation must be checked out at the time of initial start up to insure proper operation of all components. Check out should include putting the unit through one complete cycle as outlined below.

Turn on the main electrical supply and set the Comfort Control above the indicated temperature. The ignitor will automatically heat, then the Gas Valve is energized to permit the flow of gas to the burners. After ignition and flame is established, the flame control module monitors the flame and supplies power to the Gas Valve until the Comfort Control is satisfied.

To shut off.

Installer's Guide

For complete shutdown: Turn the gas cock knob on the main Gas Valve to the "OFF" position (See Figures 14 & 15).

Disconnect the electrical supply to the unit.

SEQUENCE OF OPERATION

NOTE: Whole House Air Cleaner is energized when blower is operating and there is a call for heat or cool. This can result in brief periods of blower operation with the whole house air cleaner off. This can occur during the heat fan off period or if the enhanced mode of operation is chosen for cooling.

Comfort Control call for heat (2-Stage Comfort Control) Call for 1st Stage only:

W1 Comfort Control contacts close signaling the control module to run its self-check routine. After the control module has verified that the 1st Stage Pressure Switch contacts are open and the Limit Switch(es) contacts are closed, the draft blower will be energized.

As the induced draft blower comes up to speed, the Pressure Switch contacts will close and the ignitor warm up period will begin. The ignitor will heat for approx. 20 seconds, then the Gas Valve is energized in 1st Stage to permit gas flow to the burners.

The flame sensor confirms that ignition has been achieved within the 4 second ignition trial period.

As the flame sensor confirms that ignition has been achieved, the delay to fan ON period begins timing and after approx. 45 seconds the indoor blower motor will be energized at low speed and will continue to run during the heating cycle. The whole house air cleaner will energize.

Call for 2nd Stage after 1st Stage:

W2 Comfort Control contacts close signaling a call for 2nd Stage Heat. After a 30 second delay, the induced draft blower will be energized on high speed and the 2nd Stage Pressure Switch contacts will close. The Gas Valve is energized in 2nd Stage and the indoor blower motor in high speed.

2nd Stage satisfied, 1st Stage still called:

W2 Comfort Control contacts open signaling that 2nd Stage Heating requirements are satisfied.

The induced draft blower is reduced to low speed allowing the 2nd Stage Pressure Switch contacts to open and the Gas Valve is reduced to 1st Stage. The indoor blower motor is reduced to low speed.

1st stage satisfied:

W1 Comfort Control contacts open signaling that 1st Stage heating requirements are satisfied. The Gas Valve will close and the induced draft blower and the whole house air cleaner will be de-energized. The indoor blower motor will continue to run for the fan off period (Field selectable at 60, 100, 140 or 180 seconds), then will be de-energized by the control module.

Comfort Control call for heat (1-Stage Comfort Control)

W1/ W2 (jumpered) Comfort Control contacts close signaling a call for heat. 1st Stage sequence of operation remains the same as above. 2nd Stage Heat will energize after the Stage delay timer (10 minutes) has expired.

Comfort Control satisfied:

W1/ W2 (jumpered) contacts close signaling the control module to close the Gas Valve. The induced draft blower is switched to low speed and de-energized after the post purge timer has expired. The indoor blower motor will continue to operate after the flames are extinguished and then is switched to low heat speed for the FAN-OFF period. The whole house air cleaner will be de-energized.

NOTE TO INSTALLER

Review warnings and the contents of USER'S INFORMATION MANUAL with the homeowner when installation is complete and equipment is ready to be turned over to the homeowner for normal operation.

CONTROL AND SAFETY SWITCH ADJUSTMENT

LIMIT SWITCH CHECK OUT

The limit switch is a safety device designed to close the Gas Valve should the Furnace become overheated. Since proper operation of this switch is important to the safety of the unit, it **must be checked out on initial start up by the installer.**

To check for proper operation of the Limit Switches, set the Comfort Control to a temperature higher than the indicated temperature to bring on the Gas Valve. Restrict the airflow by blocking the return air or by disconnecting the blower. When the Furnace reaches the maximum outlet temperature as shown on the rating plate, the burners must shut off. If they do not shut off after a reasonable time and overheating is evident, a faulty Limit Switch is probable and the Limit Switch must be replaced. After checking the operation of the Limit Control, be sure to remove the paper or cardboard from the return air inlet, or reconnect the blower. Refer to the Service Facts for additional instructions.

INDOOR BLOWER TIMING

WARNING

DISCONNECT POWER TO THE UNIT BEFORE REMOVING THE BLOWER DOOR.

FAILURE TO FOLLOW THIS WARNING COULD RESULT IN PROPERTY DAMAGE, PERSONAL INJURY OR DEATH.

Heating: The Integrated Furnace Control (IFC) controls the Variable Speed Indoor Blower. The blower "on" time is fixed at 45 seconds after ignition. The FAN-OFF period is field selectable by dip switches #1 and #2 located on the Integrated Furnace Control between the 5-pin and 9-pin wire connectors. The delay may be set at 60, 100, 140, or 180 seconds. The factory setting is 100 seconds (See unit wiring diagram).

Cooling: The fan delay-off period is set by dip switches on the Integrated Furnace Control. The options for cooling delay off is field selectable by dip switches #5 and #6.

The following table and graph explain the delay-off settings:

TABLE 12 FAN OFF - DELAY OPTIONS

SWITCH SETTINGS		SELECTION	NOMINAL AIRFLOW
5 - OFF	6 - OFF	NONE	SAME
5 - ON	6 - OFF	1.5 MINUTES	100% *
5 - OFF	6 - ON	3 MINUTES	50%
5 - ON	6 - ON	Enhanced Mode**	50 - 100%

This unit is equipped with a blower door switch which cuts power to the blower and Gas Valve causing shut-down when the door is removed. Operation with the door removed or ajar can permit the escape of dangerous fumes. All panels must be securely closed at all times for safe operation of the Furnace.

* - *This setting is equivalent to BAY24X045 relay benefit.*

** - *This selection provides ENHANCED MODE, which is a ramping up and ramping down of the blower speed to provide improved comfort, quietness, and potential energy savings. See Wiring Diagram notes on the unit or in the Service Facts for complete wiring setup for ENHANCED MODE. The graph which follows, shows the ramping process.*

See Wiring Diagram on the unit or in the Service Facts for complete wiring setup for Enhanced Mode.

AIRFLOW ADJUSTMENT

⚠ WARNING

Disconnect power to the unit before removing the blower door. Allow a minimum of 15 seconds for IFC power supply to discharge to 0 volts. Failure to follow this warning could result in property damage, personal injury or death.

⚠ WARNING

Operation with the door removed or ajar can permit the escape of dangerous fumes. All panels must be securely closed at all times for safe operation of the Furnace.

Failure to follow this warning could result in property damage, personal injury or death.

Check inlet and outlet air temperatures to make sure they are within the ranges specified on the Furnace rating nameplate. If the airflow needs to be increased or decreased, see the Service Facts for information on changing the speed of the blower motor.

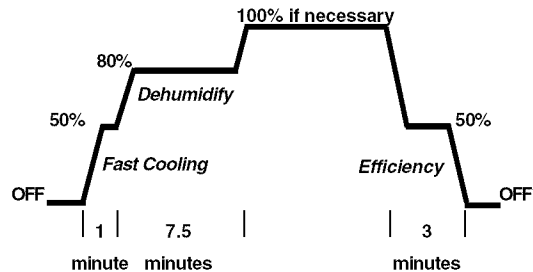

This unit is equipped with a blower door switch which cuts power to the blower and Gas Valve causing shut-down when the door is removed.

ROOM AIR COMFORT CONTROL HEAT ANTICIPATOR ADJUSTMENT

Set the Comfort Control heat anticipator according to the current flow measured, or the settings found in the notes on the Furnace wiring diagram (found in the SERVICE FACTS or inside the furnace casing).

⚠ WARNING

Should overheating occur, or the gas supply fail to shut off, shut off the Gas Valve to the unit before shutting off the electrical supply.

Failure to follow this warning could result in property damage, personal injury, or death.

INSTRUCTIONS TO THE OWNERS

In the event that electrical, fuel, or mechanical failures occur, the owner should immediately turn the gas supply off at the manual Gas Valve, located in the burner compartment. Also turn off electrical power to the Furnace and contact a qualified service technician.

BURNER BOX TEMPERATURE LIMIT DEVICE

All models are equipped with a manual reset temperature limit located on the Burner Box. In case of excessive temperature, the limit will open and cause the circuit to open which shuts off all flow of gas.

Installer's Guide

CONDITIONS THAT AFFECT SYSTEM OPERATION

1. EXCESSIVE COMBUSTION PRESSURE (WIND IN EXCESS OF 40 M.P.H.) VENT OR FLUE BLOCKAGE

If pressure against induced draft blower outlet becomes excessive, the Pressure Switch will open and shut off the Gas Valve until acceptable combustion pressure is again available.

2. LOSS OF FLAME

If loss of flame occurs during a heating cycle, or flame is not present at the sensor, the flame control module will close the Gas Valve. The flame control module will then recycle the ignition sequence, then if ignition is not achieved, it will shut off the Gas Valve and lock out the system.

3. POWER FAILURE

If there is a power failure during a heating cycle, the system will restart the ignition sequence automatically when power is restored, if the Comfort Control still calls for heat.

4. GAS SUPPLY FAILURE

If loss of flame occurs during a heating cycle, the system Integrated Control Module will recycle the ignition sequence, than if ignition is not achieved, the Integrated Control Module will shut off the Gas Valve and lock out the system.

5. INDUCED DRAFT BLOWER FAILURE

If pressure is not sensed by the Pressure Switch, the contacts will remain open and not allow the Gas Valve to open, therefore the unit will not start. If failure occurs during a running cycle, the Pressure Switch contacts will open and the Gas Valve will close to shut the unit down.

6. RESET AFTER LOCKOUT

When the Integrated Control Module has shut the system down and gone into lockout, the system must be manually reset before the unit will restart. To reset, turn the system power off, then on, then off and then on again within 30 seconds. This may be done at the unit's power source or at the Comfort Control. *The system will not reset unless the procedure off-on-off-on is completed within 30 seconds.*

WHOLE HOUSE AIR CLEANER CHECKOUT

CAUTION

Before changing the position of the High Voltage selector switch on the High Voltage power supply, make sure the power has been removed from the furnace and the High Voltage power supply.

Check out the Furnace Whole House Air Cleaner installation in accordance with this instructions page 30. Adjust ozone setting if needed. See Figure 22 on page 30.

NOTE: *Whole House Air Cleaner is energized when blower is operating and there is a call for heat or cool. This can result in brief periods of blower operation with the whole house air cleaner off. This can occur during the heat fan off period or if the enhanced mode of operation is chosen for cooling.*

WHOLE HOUSE AIR CLEANER MAINTENANCE

1. For maximum efficiency the COLLECTION CELL should be inspected and cleaned on a regular basis.

NOTE: *A 30 to 90 day cleaning interval is normal for the COLLECTION CELL and should be adjusted based upon unit run time and the home environment.*

2. The FIELD CHARGER must be removed and cleaned only by a qualified service professional.
3. The FIELD CHARGER must be cleaned at least once a year.
4. The FIELD CHARGER may require more frequent cleaning in homes with high indoor relative humidity (greater than 65% RH).
5. Consult your service professional about cleaning intervals.

WARNING

TO PREVENT INJURY OR DEATH DUE TO CONTACT WITH MOVING PARTS, TURN THE POWER TO THE FURNACE OFF BEFORE CLEANING OR SERVICING THE WHOLE HOUSE AIR CLEANER. FAILURE TO FOLLOW THIS WARNING COULD RESULT IN PROPERTY DAMAGE, PERSONAL INJURY OR DEATH.

WARNING

RISK OF ELECTRIC SHOCK: THESE SERVICING INSTRUCTIONS ARE FOR USE BY QUALIFIED PERSONNEL ONLY. TO REDUCE THE RISK OF ELECTRIC SHOCK, DO NOT PERFORM ANY SERVICING OTHER THAN THAT CONTAINED IN THESE OPERATING INSTRUCTIONS UNLESS YOU ARE QUALIFIED TO DO SO. FAILURE TO FOLLOW THIS WARNING COULD RESULT IN PROPERTY DAMAGE, PERSONAL INJURY OR DEATH.

CAUTION

High Voltage is present within the air cleaner for operation. Turn the power off and wait at least 15 seconds to allow voltage to discharge.

NOTE: System Information

Before cleaning the coil or ducts in the furnace, remove the COLLECTION CELL and FIELD CHARGER from the air cleaner. Chemicals used during the cleaning of the Furnace, or ductwork can damage the air cleaner components and degrade the performance of the air cleaner.

CLEANING THE COLLECTION CELL

1. Turn the air conditioning system off at the Comfort Control and turn off service disconnect.
2. Remove top furnace door.
3. Slide COLLECTION CELL out of Furnace.

CLEANING

The COLLECTION CELL may be cleaned either by vacuuming (recommended method) or by washing.

VACUUM CLEANING

Remove the COLLECTION CELL from the conditioned space before vacuuming. Vacuum both sides of the COLLECTION CELL to clean.

WASHING

Use low-pressure water spray, such as a sink sprayer or garden hose to clean the COLLECTION CELL. Some residue may require warm water to be removed.

- **Do NOT use soap or detergent in cleaning the COLLECTION CELL.**
- **Do NOT immerse the COLLECTION CELL completely in water.**
- **Do NOT place the COLLECTION CELL into a dishwasher to clean.**
- **ALLOW THE COLLECTION CELL TO DRY THOROUGHLY BEFORE REINSTALLING.**

Slightly tap the COLLECTION CELL to remove water retained in the filter. Allow the COLLECTION CELL to dry thoroughly before reinstalling.

CLEANING THE FIELD CHARGER

⚠ CAUTION

FIELD CHARGER PINS ARE SHARP. DO NOT BEND FIELD CHARGER PINS. WEAR APPROPRIATE GLOVES WHEN HANDLING THE FIELD CHARGER.

1. Turn off the Comfort Control and the service disconnect.
2. Turn off power to the Furnace and remove the top furnace door panel.
3. Remove COLLECTION CELL.
4. Remove the inner blower door panel by removing four screws.
5. Disconnect green return wire and red high voltage wire. To remove high voltage wire, twist and pull connector apart.
6. Remove the two 5/16" hold down screws at the front center.
7. Lift up the front of the FIELD CHARGER and slide forward to remove from the case. Lay the FIELD CHARGER on a secured flat surface.
8. Wipe down the face Plate of the FIELD CHARGER with a dry shop towel or use a vacuum cleaner. Do not disassemble the FIELD CHARGER.

Figure 19

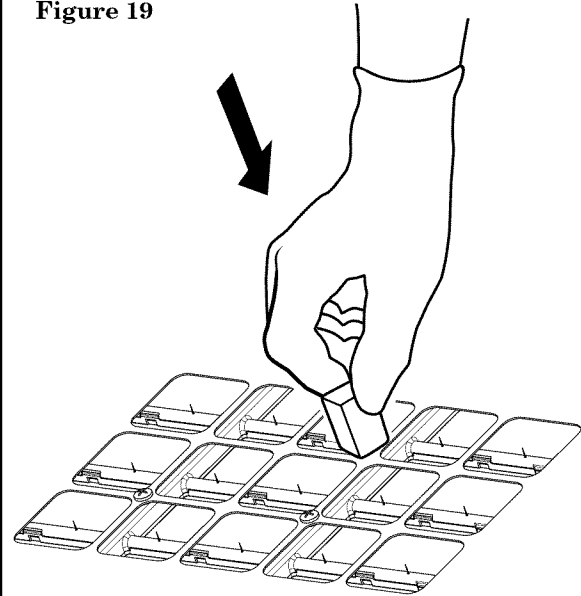
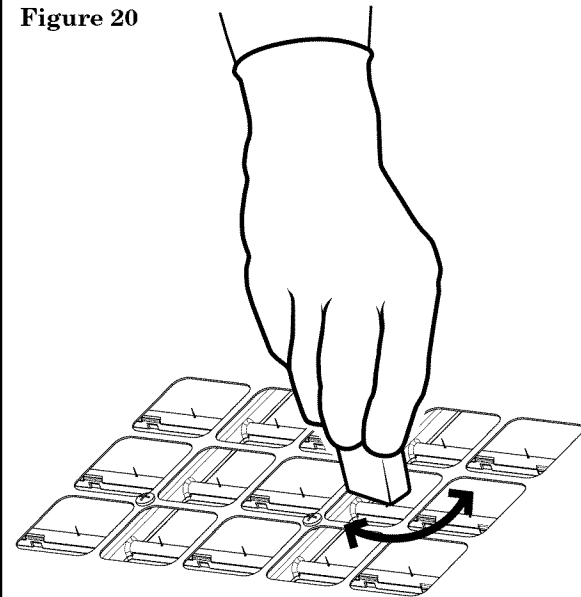

Figure 20



NOTE: Do NOT use water, soap, detergent, or chemicals to clean the FIELD CHARGER.

9. To clean pins, push a block of foam down over the FIELD CHARGER Pin.
10. Rotate the foam block on the FIELD CHARGER Pin.
11. Use the foam block to clean the faceplate opening edges.
12. Repeat steps 9 and 10 for each FIELD CHARGER Pin.
13. Reverse steps to reassemble the air cleaner. The inner blower door **MUST** be reinstalled.

Installer's Guide

INDOOR MOTOR MAINTENANCE

NOTE: Direct drive motors have bearings which are permanently lubricated and under normal use, lubrication is not recommended.

WARNING

Failure to follow safety warnings exactly, could result in a fire or explosion causing property damage, personal injury or loss of life.

- Do not store or use gasoline or other flammable vapors and liquids in the vicinity of this or any other appliance.
- **WHAT TO DO IF YOU SMELL GAS**
 - Do not try to light any appliance.
 - Do not touch any electrical switch; do not use any phone in your building.
 - Immediately call your gas supplier from a neighbor's phone. Follow the gas supplier's instructions.
 - If you cannot reach your gas supplier, call the fire department.
- Installation and service must be performed by a qualified installer, service agency or the gas supplier.

The following warning complies with State of California law, Proposition 65.

WARNING

This product contains fiberglass wool insulation!

Fiberglass dust and ceramic fibers are believed by the State of California to cause cancer through inhalation. Glasswool fibers may also cause respiratory, skin, or eye irritation.

PRECAUTIONARY MEASURES

- Avoid breathing fiberglass dust.
- Use a NIOSH approved dust/ mist respirator.
- Avoid contact with the skin or eyes. Wear long-sleeved, loose-fitting clothing, gloves, and eye protection.
- Wash clothes separately from other clothing: rinse washer thoroughly.
- Operations such as sawing, blowing, tear-out, and spraying may generate fiber concentrations requiring additional respiratory protection. Use the appropriate NIOSH approved respirator in these situations.

FIRST AID MEASURES

Eye Contact – Flush eyes with water to remove dust. If symptoms persist, seek medical attention.

Skin Contact – Wash affected areas gently with soap and warm water after handling.

INTEGRATED FURNACE CONTROL RED LED "ERROR" FLASH CODES

2 Flashes ---	System Lockout (Retries or Recycles exceeded)
3 Flashes ---	Draft Pressure Error - Possible problems: a) Venting problem b) Pressure switch problem c) Inducer problem
4 Flashes ---	Open Temperature Limit Switch
5 Flashes ---	Flame sensed when no flame should be present
6 Flashes ---	115 volt AC power reversed, ignitor (Triac) fault, poor grounding or system voltage too low
7 Flashes ---	Gas valve circuit error
8 Flashes ---	Low flame sense
9 Flashes ---	Open Inducer Limit switch
10 Flashes ---	Inducer communication error
Solid ---	Internal GV error or Low TH voltage
Solid Red w/Solid Green "STATUS" LED	Continuous Reset caused by a blown fuse or internal error.

FAULT CODE RECOVERY

On power up, last 4 Faults, if any, will be flashed on the Red LED. The newest Fault detected will flash first and the oldest last. There will be a 2 second delay between Fault Code flashes. Solid Red LED error codes will not be displayed.

The Green LED will be on solid during last Fault Recovery. At any other time the control is powered, the Green LED indicator light will operate as shown in Table 13 and the Red LED will flash LitePort data (one flash) every 20 seconds.

TABLE 13

INTEGRATED FURNACE CONTROL GREEN "STATUS" LED FLASH CODES	
Flashing Slow ---	Normal - No call for Heat
Flashing Fast ---	Normal - Call for Heat

Fault Code Reset

The last 4 Fault Codes can be erased from memory by powering up the control with "G" energized and then applying "R" to the "W1" terminal 3 times within 6 seconds. The control will acknowledge the reset by turning on the Red LED for 2 seconds.

Figure 21

*UX2/ DX2 Integrated Furnace Control

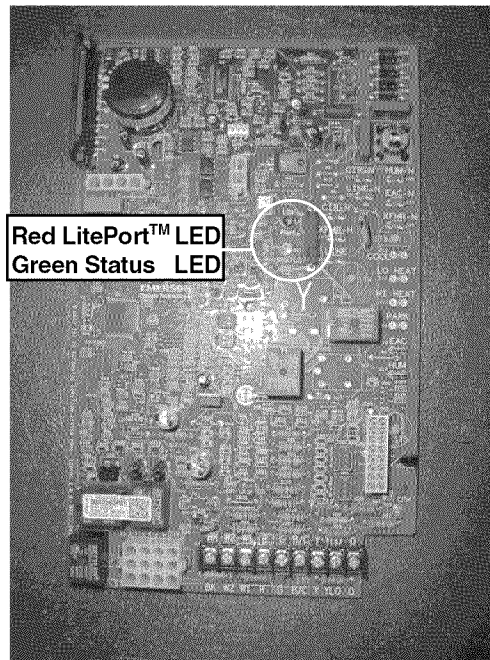

NOTE: In normal operation, the furnace makes a slight sound as the air passes through and is cleaned. In some applications, you may notice this sound coming from the return air vent(s). If desired, this sound level can be reduced with minimal impact on air cleaning efficiency by reducing the power setting of the FIELD CHARGER. The unit is shipped with the power set at 9.6KV (high). If sound is heard, reduce power level to 8.0KV (low) at the switch on the power supply. See Figure 22.

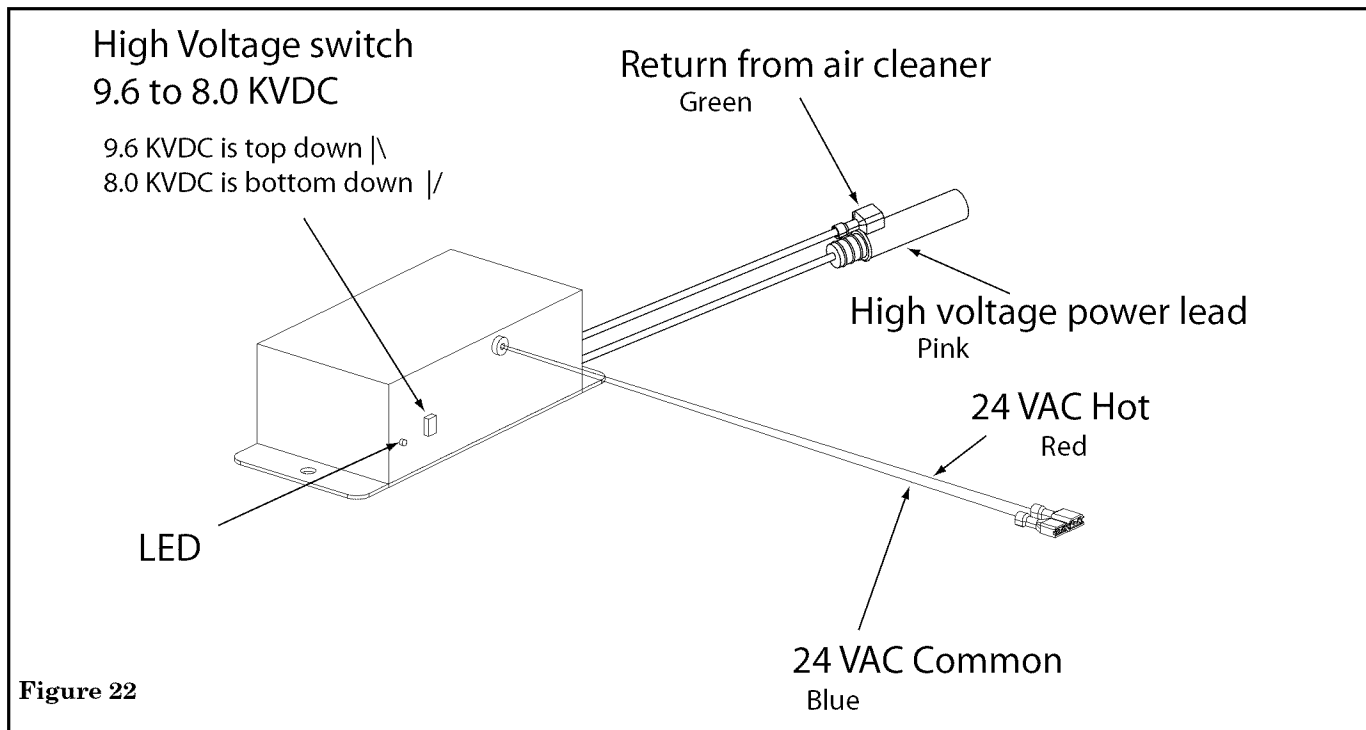

Figure 22

CHECKOUT PROCEDURES

After installation has been completed, it is recommended that the Furnace be checked against the following checklist.

- | | |
|---|---|
| <ol style="list-style-type: none"> 1. Make sure power is "OFF" at power disconnect switch [] 2. Check all field wiring for tight connections. See that grounding of unit is in accord with code ... [] 3. Make sure unit suspension (if used) is secure and that there are no tools or loose debris in, around or on top of the unit [] 4. Check all duct outlets; they must be open and unrestricted [] 5. Check drain lines and be sure all joints are tight ..
..... [] 6. Make sure secondary drain pan is installed [] 7. Check power supply for correct requirements per unit nameplate [] 8. Energize the system and carefully observe its operation; make any necessary adjustment [] 9. Adjust ozone setting, if needed [] 10. Instruct owner on proper operating procedure and leave Use and Care Manual with owner [] | <ol style="list-style-type: none"> 11. Check the Whole House Air Cleaner power output by the Green LED illumination. If the LED is on, this indicates High Voltage output to the air cleaner. [] <ol style="list-style-type: none"> a) Turn the Comfort Control to fan only. b) Remove blower door panel. |
|---|---|

⚠ WARNING

**RISK OF ELECTRICAL SHOCK
ELECTRICAL POWER IS PRESENT FOR THE NEXT 2 STEPS. THESE STEPS SHOULD BE PERFORMED ONLY BY QUALIFIED PERSONNEL.
FAILURE TO FOLLOW THIS WARNING COULD RESULT IN PERSONAL INJURY, ELECTRICAL SHOCK, OR DEATH.**

- c) Depress blower door switch.
- d) Verify with Fan running that green LED is illuminated.
- e) Release Blower Door Switch and put Blower Door back on.
- f) Turn Comfort Control to desired position.



Trane
6200 Troup Highway
Tyler, TX 75707

03/08

For more information contact
your local dealer (distributor)

Since the manufacturer has a policy of continuous product and product data improvement, it reserves the right to change design and specifications without notice.