



RTL8188CE

miniCard User's Manual

Rev. 1.0
03 Dec 2009





COPYRIGHT

©2009, All rights reserved TRENDnet,. No part of this document may be reproduced, transmitted, transcribed, stored in a retrieval system, or translated into any language in any form or by any means without the written permission of TRENDnet Inc.

DISCLAIMER

TRENDnet provides this document “as is”, without warranty of any kind, neither expressed nor implied, including, but not limited to, the particular purpose. TRENDnet may make improvements and/or changes in this document or in the product described in this document at any time. This document could include technical inaccuracies or typographical errors.

TRADEMARKS

TRENDnet is a trademark of TRENDnet Semiconductor Corporation. Other names mentioned in this document are trademarks/registered trademarks of their respective owners.

USING THIS DOCUMENT

This document is intended for the software engineer’s reference and provides detailed programming information.

Though every effort has been made to ensure that this document is current and accurate, more information may have become available subsequent to the production of this guide. In that event, please contact your TRENDnet representative for additional information that may help in the development process.



Table of Contents

1. GENERAL DESCRIPTION.....	1
2. FEATURES.....	2
3. BLOCK DIAGRAM.....	3
4. PRODUCT SPECIFICATIONS.....	4
4.1. MINI PCI EXPRESS PIN ASSIGNMENT.....	4
4.2. MECHANICAL.....	5
4.3. ENVIRONMENTAL.....	5
4.3.1. Operating.....	5
4.3.2. Storage.....	5
4.4. FUNCTIONAL SPECIFICATIONS.....	5
4.5. WARNING.....	6
4.5.1 Federal Communication Commission Interference Statement.....	6
4.5.2 Industry Canada Statement.....	8
4.5.3 NCC警語.....	9

List of Tables

TABLE 1. MINI PCI EXPRESS PIN ASSIGNMENT.....	4
TABLE 2. FUNCTIONAL SPECIFICATIONS.....	5

List of Figures

FIGURE 1. RTL8188CE MINICARD APPLICATION DIAGRAM.....	3
FIGURE 2. RTL8188CE MINICARD MECHANICAL SPECIFICATION.....	5



1. General Description

The TRENDnet RTL8188CE is a highly integrated single-chip Wireless LAN (WLAN) controller compatible with the IEEE 802.11n specification. It combines a MAC, a 1T1R capable baseband, and RF in a single chip. The RTL8188CE provides a complete solution for a high-performance wireless client.

The RTL8188CE baseband implements Multiple Input, Multiple Output (MIMO) Orthogonal Frequency Division Multiplexing (OFDM) with one transmit and one receive path (1T1R). Features include one spatial stream transmission, short Guard Interval (GI) of 400ns, spatial spreading, and support for both 20MHz and 40MHz channel bandwidth.

For legacy compatibility, Direct Sequence Spread Spectrum (DSSS), Complementary Code Keying (CCK) and OFDM baseband processing are included to support all IEEE 802.11b, and 802.11g data rates. Differential phase shift keying modulation schemes, DBPSK and DQPSK with data scrambling capability are available, and CCK provides support for legacy data rates, with long or short preamble. The high speed FFT/IFFT paths, combined with BPSK, QPSK, 16QAM, and 64QAM modulation of the individual subcarriers, and rate compatible punctured convolutional coding with coding rate of 1/2, 2/3, 3/4, and 5/6, provide higher data rates of 54Mbps and 150Mbps for IEEE 802.11g and 802.11n OFDM respectively.

The RTL8188CE builds in an enhanced signal detector, an adaptive frequency domain equalizer, and a soft-decision Viterbi decoder to alleviate severe multi-path effects and mutual interference in the reception of multiple streams. Robust interference detection and suppression are provided to protect against Bluetooth, cordless phone, and microwave oven interference.

Efficient IQ-imbalance, DC offset, phase noise, frequency offset, and timing offset compensations are provided for the radio frequency front-end. Selectable digital transmit and receive FIR filters are provided to meet transmit spectrum mask requirements and to reject adjacent channel interference, respectively.

The RTL8188CE supports fast receiver Automatic Gain Control (AGC) with synchronous and asynchronous control loops among antennas, antenna diversity functions, and adaptive transmit power control functions to obtain better performance in the analog portions of the transceiver.

The RTL8188CE MAC supports 802.11e for multimedia applications, 802.11i for security, and 802.11n for enhanced MAC protocol efficiency. Using packet aggregation techniques such as A-MPDU with BA and A-MSDU, protocol efficiency is significantly improved. Power saving mechanisms such as U-APSD, and APSD, reduces power wasted during idle time, and compensates for the extra power required to transmit OFDM. The RTL8188CE provides simple legacy and 20MHz/40MHz co-existence mechanisms to ensure backward and network compatibility.



2. Features

General

- 48-pin QFN
- CMOS MAC, Baseband PHY and RF in a single chip for IEEE 802.11b/g/n compatible WLAN
- 75Mbps receive PHY rate and 75Mbps transmit PHY rate using 20MHz bandwidth
- 150Mbps receive PHY rate and 150Mbps transmit PHY rate using 40MHz bandwidth
- Compatible with 802.11n specification
- Backward compatible with 802.11b/g devices while operating at 802.11n data rates

Host Interface

- Complies with PCI Express Base Specification Revision 1.1 / USB 2.0

Standards Supported

- IEEE 802.11b/g/n compatible WLAN
- IEEE 802.11e QoS Enhancement (WMM)
- IEEE 802.11i (WPA, WPA2). Open, shared key, and pair-wise key authentication services

MAC Features

- Frame aggregation for increased MAC efficiency (A-MSDU, A-MPDU)
- Low latency immediate High-Throughput Block Acknowledgement (HT-BA)
- Long NAV for media reservation with CF-End for NAV release
- PHY-level spoofing to enhance legacy compatibility
- Power saving mechanism
- Channel management and co-existence
- Multiple BSSID feature allows the

RTL8188CE to assume multiple MAC identities when used as a wireless bridge

- Supports Wake-On-WLAN via Magic Packet and Wake-up frame
- Transmit Opportunity (TXOP) Short Inter-Frame Space (SIFS) bursting for higher multimedia bandwidth

Peripheral Interfaces

- General Purpose Input/Output (8 pins)
- Three configurable LED pins
- Configurable Bluetooth Coexistence Interface

PHY Features

- IEEE 802.11n OFDM
- One Transmit and one Receive path (1T1R)
- 20MHz and 40MHz bandwidth transmission
- Short Guard Interval (400ns)
- DSSS with DBPSK and DQPSK, CCK modulation with long and short preamble
- OFDM with BPSK, QPSK, 16QAM, and 64QAM modulation. Convolutional Coding Rate: 1/2, 2/3, 3/4, and 5/6
- Maximum data rate 54Mbps in 802.11g, and 150Mbps in 802.11n
- Switch diversity for DSSS/CCK
- Hardware antenna diversity
- Selectable digital transmit and receive FIR filters
- Programmable scaling in transmitter and receiver to trade quantization noise against increased probability of clipping
- Fast receiver Automatic Gain Control (AGC)
- On-chip ADC and DAC

3. Block Diagram

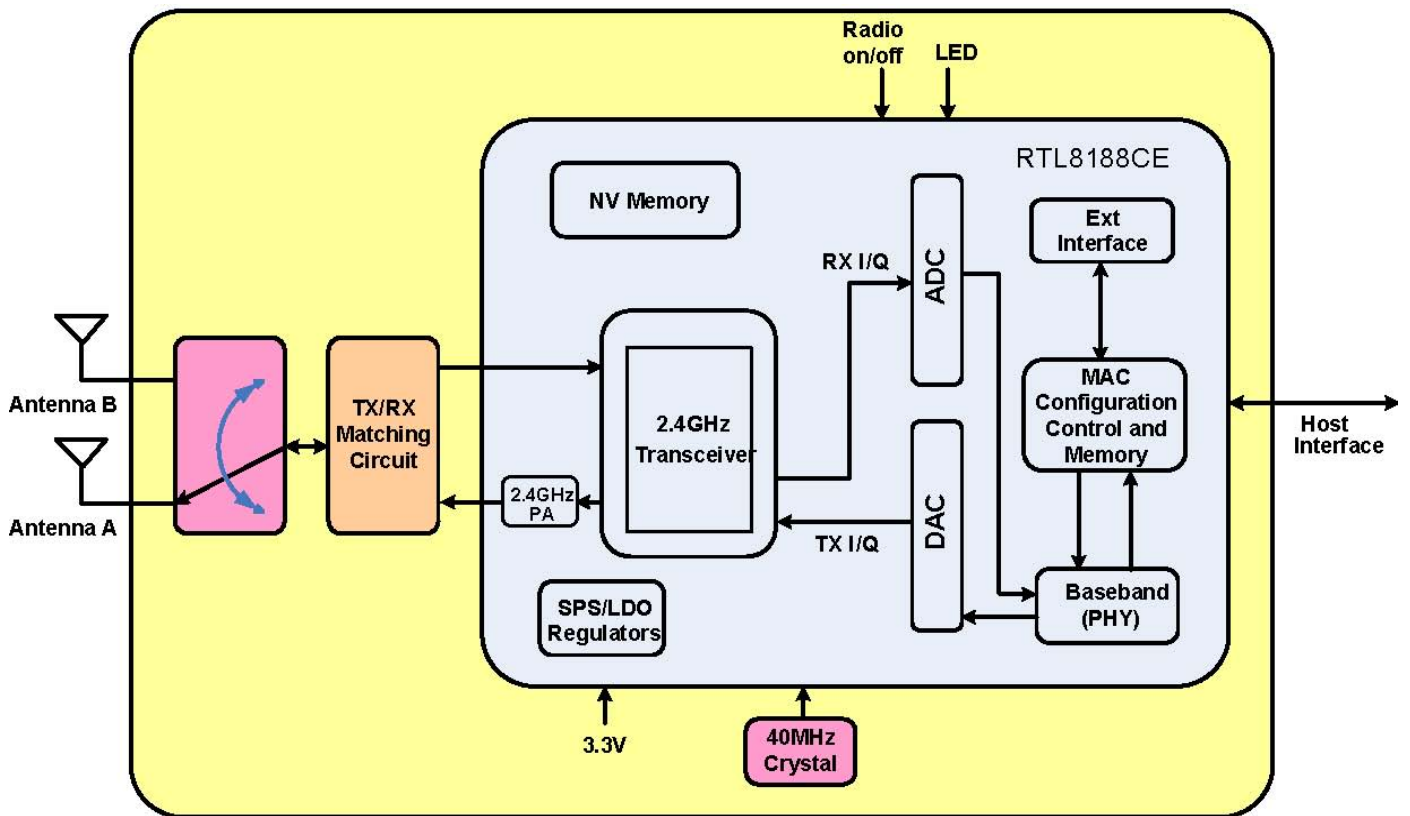

Figure 1. RTL8188CE miniCard Application Diagram



4. Product specifications

4.1. Mini PCI Express Pin Assignment

Table 1. Mini PCI Express Pin Assignment

PIN#	Pin Name		PIN#	Pin Name	
1	WAKE#	YES	2	3.3Vaux	YES
3	COEX1	YES	4	GND	YES
5	COEX2	YES	6	1.5V	NC
7	CLKREQ#	YES	8	UIM_PWR	NC
9	GND	YES	10	UIM_DATA	NC
11	REFCLK-	YES	12	UIM_CLK	NC
13	REFCLK+	YES	14	UIM_RESET	NC
15	GND	YES	16	UIM_VPP	NC
17	RESERVED	NC	18	GND	YES
19	RESERVED	NC	20	W_DISABLE#	YES
21	GND	YES	22	PERST#	YES
23	PERn0	YES	24	+3.3Vaux	NC
25	PERp0	YES	26	GND	YES
27	GND	YES	28	+1.5V	NC
29	GND	YES	30	SMB_CLK	NC
31	PETn0	YES	32	SMB_DATA	NC
33	PETp0	YES	34	GND	YES
35	GND	YES	36	USB_D-	YES
37	GND	YES	38	USB_D+	YES
39	+3.3Vaux	NC	40	GND	NC
41	+3.3Vaux	NC	42	LED_WWAN#	NC
43	GND	YES	44	LED_WLAN#	YES
45	RESERVED	NC	46	LED_WPAN#	NC
47	RESERVED	NC	48	+1.5V	YES
49	RESERVED	NC	50	GND	YES
51	RESERVED	NC	52	+3.3Vaux	YES



Transfer rate	802.11b: 11 / 5.5 / 2 / 1Mbps 802.11g: 54 / 48 / 36 / 24 / 18 / 12 / 9 / 6Mbps Draft 802.11n (20MHz, 800ns GI): 65 / 58.5 / 52 / 39 / 26 / 19.5 / 13 / 6.5Mbps Draft 802.11n (40MHz, 800ns GI): 135 / 121.5 / 108 / 81 / 54 / 40.5 / 27 / 13.5Mbps Draft 802.11n (20MHz, 400ns GI): 72.2 / 65 / 57.8 / 43.3 / 28.9 / 21.7 / 14.4 / 7.2Mbps Draft 802.11n (40MHz, 400ns GI): 150 / 135 / 120 / 90 / 60 / 45 / 30 / 15Mbps
FREQUENCY Range	2400MHz ~ 2483.5MHz
NUMBER OF CHANNEL	11 for 802.11b, 802.11g, draft 802.11n (20MHz) 7 for draft 802.11n (40MHz)

4.5. Warning

4.5.1 Federal Communication Commission Interference Statement

This equipment has been tested and found to comply with the limits for a Class B digital device, pursuant to Part 15 of the FCC Rules. These limits are designed to provide reasonable protection against harmful interference in a residential installation. This equipment generates, uses and can radiate radio frequency energy and, if not installed and used in accordance with the instructions, may cause harmful interference to radio communications. However, there is no guarantee that interference will not occur in a particular installation. If this equipment does cause harmful interference to radio or television reception, which can be determined by turning the equipment off and on, the user is encouraged to try to correct the interference by one of the following measures:

- Reorient or relocate the receiving antenna.
- Increase the separation between the equipment and receiver.
- Connect the equipment into an outlet on a circuit different from that to which the receiver is connected.
- Consult the dealer or an experienced radio/TV technician for help.

This device complies with Part 15 of the FCC Rules. Operation is subject to the following two conditions: (1) This device may not cause harmful interference, and (2) this device must accept any interference received, including interference that may cause undesired operation.

FCC Caution: Any changes or modifications not expressly approved by the party responsible for compliance could void the user's authority to operate this equipment.

IMPORTANT NOTE:

FCC Radiation Exposure Statement:

This equipment complies with FCC radiation exposure limits set forth for an uncontrolled environment. This equipment should be installed and operated with minimum distance 20cm between the radiator & your body.



This transmitter must not be co-located or operating in conjunction with any other antenna or transmitter.

IEEE 802.11b or 802.11g operation of this product in the U.S.A. is firmware-limited to channels 1 through 11.

This device is intended only for OEM integrators under the following conditions:

The antenna must be installed such that 20 cm is maintained between the antenna and users, and

The transmitter module may not be co-located with any other transmitter or antenna,

For all products market in US, OEM has to limit the operation channels in CH1 to CH11 for 2.4G band by supplied firmware programming tool. OEM shall not supply any tool or info to the end-user regarding to Regulatory Domain change.

As long as 3 conditions above are met, further transmitter test will not be required. However, the OEM integrator is still responsible for testing their end-product for any additional compliance requirements required with this module installed (for example, digital device emissions, PC peripheral requirements, etc.).

IMPORTANT NOTE: In the event that these conditions can not be met (for example certain laptop configurations or co-location with another transmitter), then the FCC authorization is no longer considered valid and the FCC ID can not be used on the final product. In these circumstances, the OEM integrator will be responsible for re-evaluating the end product (including the transmitter) and obtaining a separate FCC authorization.

End Product Labeling

This transmitter module is authorized only for use in device where the antenna may be installed such that 20 cm may be maintained between the antenna and users. The final end product must be labeled in a visible area with the following: "Contains FCC ID: XU8RTL8188CE".

Manual Information To the End User

The OEM integrator has to be aware not to provide information to the end user regarding how to install or remove this RF module in the user's manual of the end product which integrates this module.

The end user manual shall include all required regulatory information/warning as show in this manual.

Industry Canada Statement

This device complies with RSS-210 of the Industry Canada Rules. Operation is subject to the following two conditions:

- 1) this device may not cause interference and
- 2) this device must accept any interference, including interference that may cause undesired operation of the device

This device has been designed to operate with an antenna having a maximum gain of 3.45dBi.

Antenna having a higher gain is strictly prohibited per regulations of Industry Canada. The required antenna impedance is 50 ohms.

To reduce potential radio interference to other users, the antenna type and its gain should be so chosen that the EIRP is not more than required for successful communication.



IMPORTANT NOTE:

IC Radiation Exposure Statement:

This equipment complies with IC radiation exposure limits set forth for an uncontrolled environment. This equipment should be installed and operated with minimum distance 20cm between the radiator & your body.

4.5.2 Industry Canada Statement

This device complies with RSS-210 of the Industry Canada Rules. Operation is subject to the following two conditions:

- 1) this device may not cause interference and
- 2) this device must accept any interference, including interference that may cause undesired operation of the device

This device has been designed to operate with an antenna having a maximum gain of 3.45dBi.

Antenna having a higher gain is strictly prohibited per regulations of Industry Canada. The required antenna impedance is 50 ohms.

To reduce potential radio interference to other users, the antenna type and its gain should be so chosen that the EIRP is not more than required for successful communication.

IMPORTANT NOTE:

IC Radiation Exposure Statement:

This equipment complies with IC radiation exposure limits set forth for an uncontrolled environment. This equipment should be installed and operated with minimum distance 20cm between the radiator & your body.

This device is intended only for OEM integrators

under the following conditions:

The transmitter module may not be co-located with any other transmitter or antenna.

As long as conduction above is met, further transmitter test will not be required. However, the OEM integrator is still responsible for testing their end-product for any additional compliance requirements required with this module installed (for example, digital device emissions, PC peripheral requirements, etc.). The antenna must be installed such that 20 cm is maintained between the antenna and users.

IMPORTANT NOTE: In the event that these conditions can not be met (for example certain laptop configurations or co-location with another transmitter), then the IC authorization is no longer considered valid and the IC ID can not be used on the final product. In these circumstances, the OEM integrator will be responsible for re-evaluating the end product (including the transmitter) and obtaining a separate IC authorization.



End Product Labeling

The final end product must be labeled in a visible area with the following: “Contains IC : 6317A-RTL8188CE”.

Manual Information That Must be Included

The OEM integrator has to be aware not to provide information to the end user regarding how to install or remove. This RF module in the user’s manual of the end product which integrates this module.

The user’s manual for OEM Integrators must include the following information in a prominent location “IMPORTANT NOTE: To comply with FCC RF exposure compliance requirements. The antenna must not be co-located or operating in conjunction with any other antenna or transmitter”.

4.5.3 NCC警語

經型式認證合格之低功率射頻電機，非經許可，公司、商號或使用者均不得擅自變更頻率、加大功率或變更原設計之特性及功能。

低功率射頻電機之使用不得影響飛航安全及干擾合法通信；經發現有干擾現象時，應立即停用，並改善至無干擾時方得繼續使用。前項合法通信，指依電信法規定作業之無線電通信。低功率射頻電機須忍受合法通信或工業、科學及醫療用電波輻射性電機設備之干擾。

本模組於取得認證後將依規定於模組本體標示審合格籤，並要求平台上標示「本產品內含射頻模組：ID編號」

TRENDnet Inc.
20675 Manhattan Place, CA 90501
Tel: 310-961-5500 Fax: 310-961-5511
www.trendnet.com