

# TrickleStar TS6001BT\_BT\_MODULE

## Operational Description



## **1.1 Product Overview**

The TS6001BT MODULE is a Low energy module for easy communication via the Bluetooth Low Energy Protocol, it provides communication with almost any mobile device, such as smartphones, tablets and Bluetooth enabled PCs.

Based on the widely used NRF52832 BLE SoC paired with a fixed onboard PCB antenna, this is a low-cost robust solution for wireless communication. The intended use of the module is 1 Mbps at 4 dBm transmitter power.

Integrated ARM® Cortex®-M4 32-bit processor with FPU, on-chip memory and over-the-air firmware upgradeability.

## 1.2 Product Specification

Operating Frequency	2400-2483.5 MHz
No. of channels	40
Channel spacing	2 MHz
Modulation type	GFSK
Transmitter power	-20 to 0dBm TX power, configurable in 4 dB steps
Supported data rates	1 Mbps \ 2 Mbps
Antenna type	PCB antenna (Meandered Inverted-F Antenna (MIFA))
Receiver sensitivity	-96 dBm
Number of antenna	One
Antenna gain	1.6 dBi
Supply voltage	3.3 V
Environmental	-40 to +85 °C (Operation)

Table 1: nRF52832 datasheet: [http://infocenter.nordicsemi.com/pdf/nRF52832\\_PS\\_v1.4.pdf](http://infocenter.nordicsemi.com/pdf/nRF52832_PS_v1.4.pdf)

### 1.3 Block Diagram

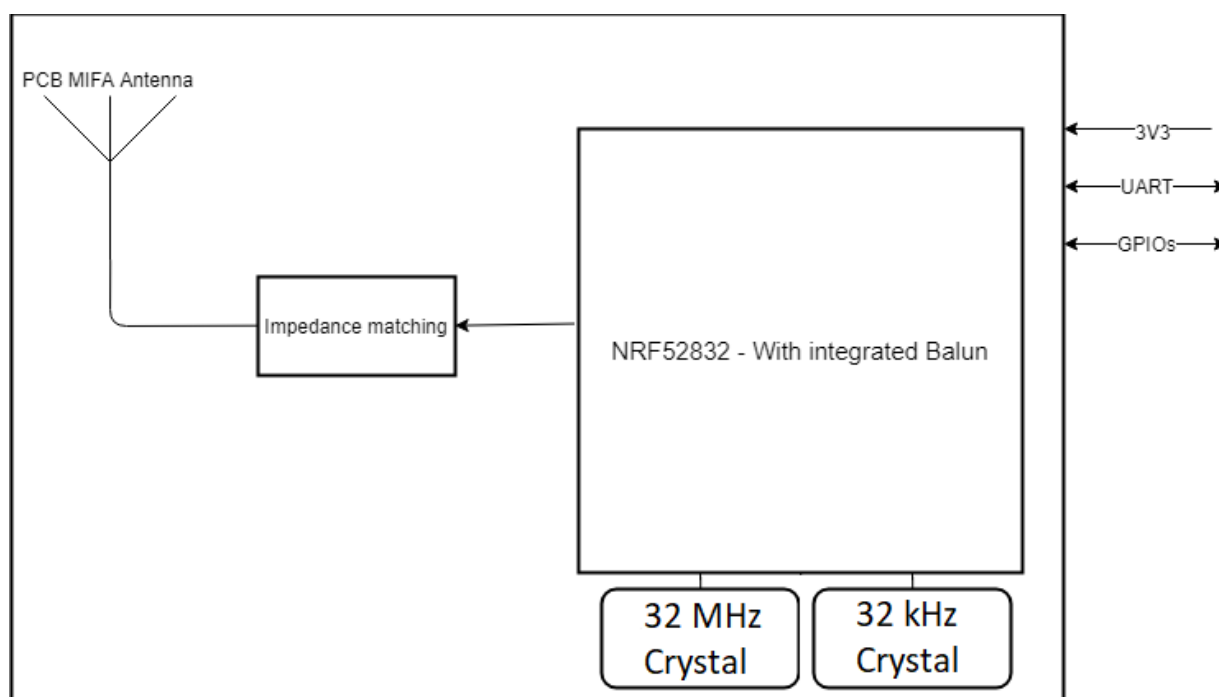

#### Interference Statement

##### FCC Statement:

This device complies with part 15 of the FCC Rules. Operation is subject to the following two conditions: (1) This device may not cause harmful interference, and (2) this device must accept any interference received, including interference that may cause undesired operation.

This equipment complies with FCC radiation exposure limits set forth for an uncontrolled environment. This equipment should be installed and operated with minimum distance 20cm between the radiator & your body.

NOTE: This equipment has been tested and found to comply with the limits for a Class B digital device, pursuant to part 15 of the FCC Rules. These limits are designed to provide reasonable protection against harmful interference in a residential installation.

This equipment generates, uses and can radiate radio frequency energy and, if not installed and used in accordance with the instructions, may cause harmful interference to radio communications. However, there is no guarantee that interference will not occur in a particular installation.

If this equipment does cause harmful interference to radio or television reception, which can be determined by turning the equipment off and on, the user is encouraged to try to correct the interference by one or more of the following measures:

- Reorient or relocate the receiving antenna.
- Increase the separation between the equipment and receiver.
- Connect the equipment into an outlet on a circuit different from that to which the receiver is connected.
- Consult the dealer or an experienced radio/TV technician for help.

Changes or modifications not expressly approved by the party responsible for compliance could void the user's authority to operate the equipment.

##### IC statement:

This device complies with Industry Canada license-exempt RSS standard(s). Operation is subject to the following two conditions: (1) this device may not cause interference, and (2) this device must accept any interference, including interference that may cause undesired operation of the device.

Le présent appareil est conforme aux CNR d'Industrie Canada applicables aux appareils radio exempts de licence. L'exploitation est autorisée aux deux conditions suivantes : (1) l'appareil ne doit pas produire de brouillage, et (2) l'utilisateur de l'appareil doit accepter tout brouillage radioélectrique subi, même si le brouillage est susceptible d'en compromettre le fonctionnement.

This equipment complies with IC radiation exposure limits set forth for an uncontrolled environment. This equipment should be installed and operated with minimum distance 20cm between the radiator & your body.

The final end product must be labeled in a visible area with the following: "Contains FCC ID:2AG8Q-TS6001BT", "contains IC: 7723A-TS6001BT". The grantee's FCC ID can be used only when all FCC/ IC compliance requirements are met.