

***EXHIBIT C***

***User Manual***

# *MSP Series*

**24 Wire Dot Matrix Printer**

*Quick Reference Manual*

***TVS Electronics Ltd.***

34, Developed Plots, South Phase,  
Industrial Estate, Guindy, Chennai - 600 032.  
Phone : +91-44-232 5506 Fax : +91-44-232 7577  
Web : [www.tvs-e.com](http://www.tvs-e.com)

---

Postage  
will be  
paid by  
addressee

## BUSINESS REPLY CARD

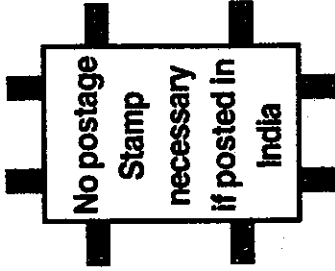

TN / CH (S) - 144  
Guindy Post Office, Chennai - 600 032.



# TVS

ELECTRONICS

**TVS Electronics Limited**  
34, Developed Plots, South Phase,  
Industrial Estate, Guindy, Chennai - 600 032.  
Phone : +91-44-232 5506

## Warranty Registration Card



**Dear Customer,**

We thank you for purchasing our product and we appreciate your intelligent choice. It is most essential to post this pre-paid installation card, duly filled in to avail warranty service. Registering your address with us, will enable you to receive special mailers on updates, discount scheme etc., whenever they are announced. Warranty service is liable for rejection. If the registration card is not posted. Hence please post it today. Do write to us for any future service support or contact our branch office or Authorised Service Centre

***Please Use Block Letters***

Your Name	:	.....
Address	:	..... ..... .....Pin .....
Phone No	.....	Fax .....
Product	.....	Mode .....
Unit SI No.	.....	.....

Purchased from M/s	.....			
Address	..... ..... .....Pin .....			
Invoice No.	.....	Date .....		
The above organisation is :	<table border="1"><tr><td>NSI</td><td>TVS-E ADP</td><td>RESELLER</td></tr></table>	NSI	TVS-E ADP	RESELLER
NSI	TVS-E ADP	RESELLER		
Any other please specify :	.....			

Seal

Signature :

Date :

*This Manual is meant for Reference only*

*For detailed information refer to*

**ELECTRONIC GUIDE**

*in the CD/Floppy provided*

*to you with your MSP Printer.*

---



---

*MSP Series*

---

## TVS CARE LINE

Dear Customer,

*Congratulations* for having made the intelligent choice of buying a TVS product. This product is designed and manufactured with utmost care to give you high quality, trouble-free performance in the years to come.

Please register your product by filling the enclosed Business Reply Card and mailing it to us. This will enable you to avail free warranty services, in the unlikely requirement of any service assistance. This registration will also entitle you to receive free mailers on product upgrades, service campaigns, etc. In case you do not find the Business Reply Card in this manual, please write to us for a new registration card:

Customer Support  
TVS Electronics Limited  
34, Developed Plots, South Phase,  
Industrial Estate, Guindy,  
Chennai - 600 032.

## *MSP Series*

---

**Please note that it is mandatory to register your product with us. The warranty applicable for this product is likely to be rejected in case of non-registration of your product with us.**

For any queries on our products and/or services, you can contact either our branch office or our authorized service provider. List of service providers is enclosed in a separate booklet.

For on-line support, please contact *your nearest callcenter* an exclusive Tele-solution desk available for any TVS customers. The contact details are:

Call Center Chennai	:	(91) (044) 2322511/2322399
Care Fax	:	(91) (044) 2327588
E-mail	:	careline@esa.tvse.co.in
Call Center B'lore	:	(91) (080) 2276172/2274584
Call Center Mumbai	:	(91) (022) 7905717, 718

We wish you a happy and memorable association with your TVS product.

## CONTENTS

Page No

### Basics

Locating the right place for your printer -----	1
What does your carton contain ? -----	1
Unpacking your printer -----	2
Installing your MSP Printer -----	2
Components in your MSP Printer -----	3
Installing the Ribbon Cartridge -----	4
Operating the Control Panel -----	6
Micro Line settings -----	7
Line Feed and Form Feed -----	7
Paper Park -----	7
Selecting copy mode -----	8
Programming the Macros -----	8
<b>Selecting and Loading Paper</b>	
Paper Select lever -----	11
Top of Form Settings -----	11
Push Tractor -----	12
Pull Tractor -----	15
Bottom Feed -----	18
Printing on single sheet -----	19
<b>Helpful Hints</b> -----	21
<b>MSP Product Specifications</b> -----	23



### **Locating the right place for your MSP Printer**

Locate a flat and sturdy surface which allows the paper to flow freely.

- ▲ Choose a Power outlet (wall socket which is closest to the power socket in the printer to avoid messy routing of power cable)
- ▲ Ensure your Printer is placed at a dust free location.
- ▲ Avoid exposing your printer to excessive heat.
- ▲ Always ensure your printer has a steady source of 220/240 V electricity.

### **What does your Carton contain ?**

- ▲ Printer - MSP XXX
- ▲ Paper insertion plate
- ▲ Power Cord
- ▲ This Quick Reference Manual with CDROM
- ▲ Ribbon Cartridge
- ▲ Parallel Interface Cable
- ▲ Dust Cover
- ▲ Printer Stand

## Unpacking your printer

- ⤴ You will find two buffers on either sides of the Printer.
- ⤴ Gently hold both the buffers and lift up.
- ⤴ Never lift the printer by holding any part of the printer.

## Installing your MSP Printer

- ⤴ After placing the printer on the selected location, remove all the protective tapes you find.
- ⤴ You have been provided with a parallel interface cable. Connect them to your computer and printer.
- ⤴ Install the power cord and make sure you have provided proper earthing.

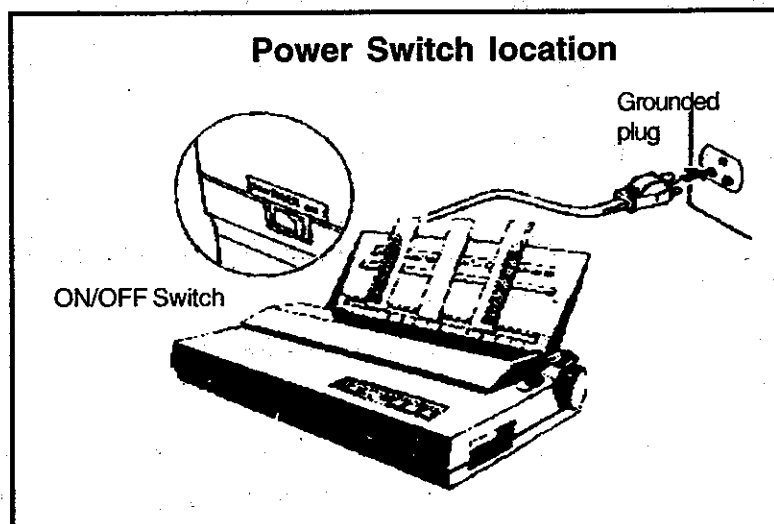

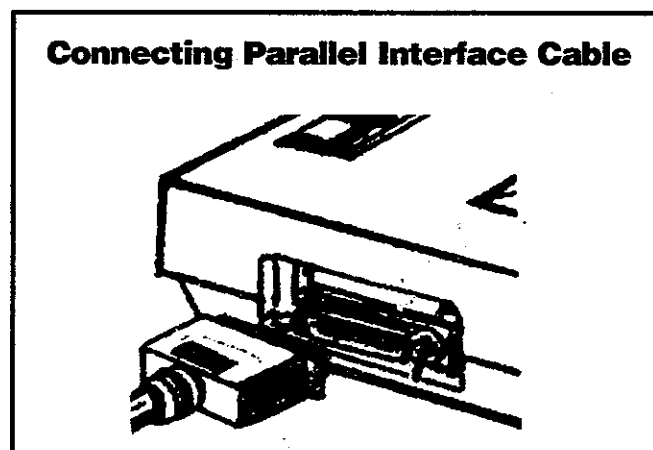

### Components in your MSP printer

- ▲ On the left rear side of the printer you will find the **POWER SWITCH**.
- ▲ On the rear side of the printer you will find **TRACTOR** with sprockets to fit continuous (fanfold) stationery.
- ▲ On the right side besides the interface cable insertion you will find a circular knob "**PAPER FEED KNOB**".
- ▲ Above the paper feed knob you will find the "**PAPER SELECT LEVER**". - To select between friction and pin mode of paper feeding.
- ▲ "Paper Insertion Plate" has been provided with Guides which helps you to feed single sheets.
- ▲ When you open top cover, on the right side you will find "**Paper Thickness Lever**".
- ▲ On the tractor unit to your left, you find the "**PAPER PARK LEVER**" where you can select between single sheet and continuous sheets.

## Installing the Ribbon Cartridge

- ▲ When installing the Ribbon Cartridge ensure that the printer is Powered “OFF”.
- ▲ Lift the top cover, you will find there are “LIFT” labels indicated.
- ▲ Remove the packing materials provided with the Ribbon Cartridge.
- ▲ Hold the Ribbon Cartridge with the round knob which is located on the left side of the ribbon (top position).
- ▲ Gently rotate the knob on the direction indicated beside the knob.
- ▲ Place the Ribbon on the top of the print head.
- ▲ Insert the Ribbon Cartridge between the print head and chrome ribbon guide.
- ▲ After inserting the ribbon, move the print head right and left a few times to ensure that the ribbon has been installed properly.

(Refer to the Figure in the next page)

## Installing the Printer Ribbon

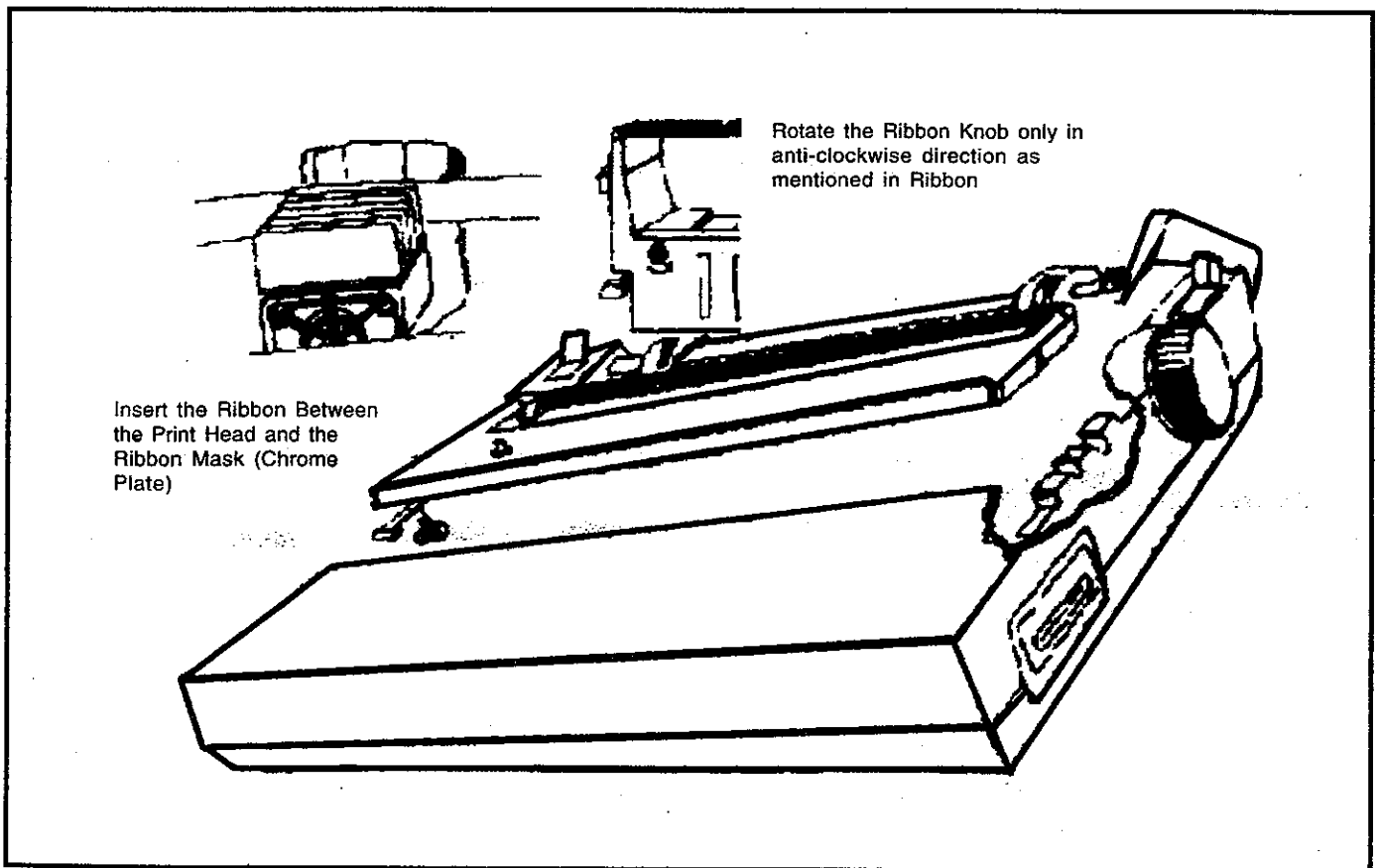

## Operating the Control Panel

- ▲ The **ONLINE** light is in the top left corner of the control panel. When the 'ON LINE' light glows, the printer is in **ONLINE** mode, when it is **OFF**, the printer is in **OFFLINE** mode, and light blinks when the printer is out of paper.
- ▲ MSP 3XX has two Draft fonts and 9 Letter quality fonts. Keep the printer in 'OFF LINE' mode. Use the Font switch to scroll through the available Fonts. The Font light indicates the particular Font you have chosen.
- ▲ **PITCH** light indicates the character pitch chosen.

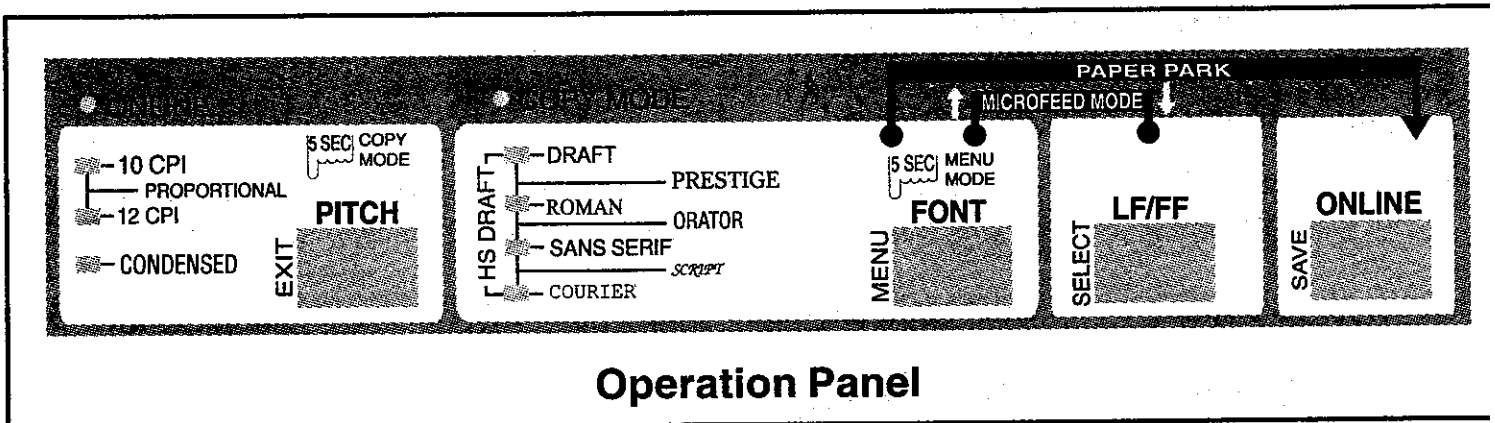

---

### Micro Line Settings

- ▲ Keep the printer in **ONLINE** mode.
- ▲ Press the **FONT** switch and **LF/FF** switch to go into the **MICRO LINE** mode. After going to the **MICRO LINE** mode press the Font switch. This is the **Forward Micro Line Feed**.
- ▲ If you require to reverse the paper press **LF/FF** switch. This is the **Reverse Micro Line Feed**.
- ▲ To save the **TOP OF FORM** settings press the **ONLINE** switch.

### Line Feed & Form Feed (LF/FF)

- ▲ Keep the printer in **OFFLINE** mode.
- ▲ Each time you press the **LF/FF** switch the printer advances by one line. This is the **LINE FEED (LF)**
- ▲ Hold the **LF/FF** switch for 2 seconds, the continuous form is advanced to the next top of Form, where as the single sheet gets ejected. This is the **FORM FEED (FF)**.

### Paper Park

- ▲ Keep the printer in **OFFLINE / ONLINE** mode.
- ▲ Hold the **FONT** switch and press the **ONLINE** switch to park continuous form.

### Selecting Copy mode

- ▲ Keep the printer in **ONLINE** mode.
- ▲ Hold the **PITCH** switch for 5 seconds to toggle the Copy Mode status.
- ▲ Lighting of Copy Mode light indicates that the printer is in copy mode.

### Programming the Macros Entering MENU mode

- ▲ Insert a paper into the printer.
- ▲ Keep the printer in '**ON LINE**' mode.
- ▲ Press the **FONT** switch for 5 seconds to go to the Menu mode.
- ▲ Now the printer enters the Macro programming mode (**MENU MODE**).
- ▲ The bottom **FONT** light keeps flashing as an indication.
- ▲ The print head is used as the **POINTER** to select an option.



## Selecting Options

- ▲ To move to the next row or record, press **MENU** switch.
- ▲ Press the **LF/FF (SELECT)** switch to select the Macros.
- ▲ Now the print head moves to the right and places it under the next field.
- ▲ After reaching the last field, the print head is moved to the first field.

## Saving the current field setting

- ▲ Now you have selected the right record and field (printed in bold).
- ▲ Press **ONLINE (SAVE)** switch to save a particular field.
- ▲ The printer prints light shade on the field to confirm the field you have chosen to save has been saved.

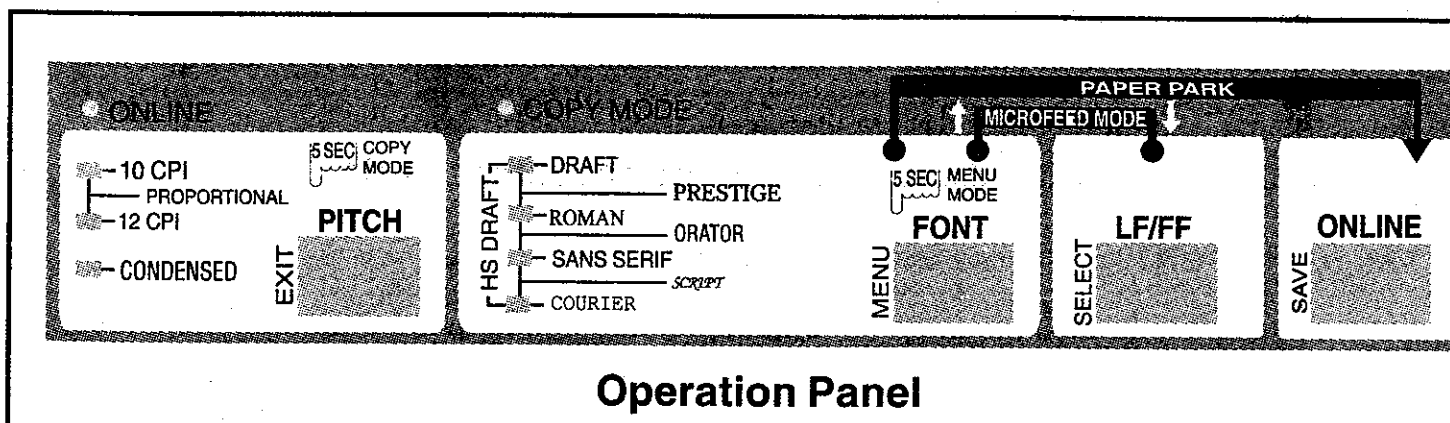

Operation Panel

### Quitting the MENU mode

- ▲ Finally Press the **PITCH (EXIT)** switch to save & exit from the Menu mode.
- ▲ Now switch **OFF** the printer.

The table given below indicates the name of the switch and its function in the **MENU** mode.

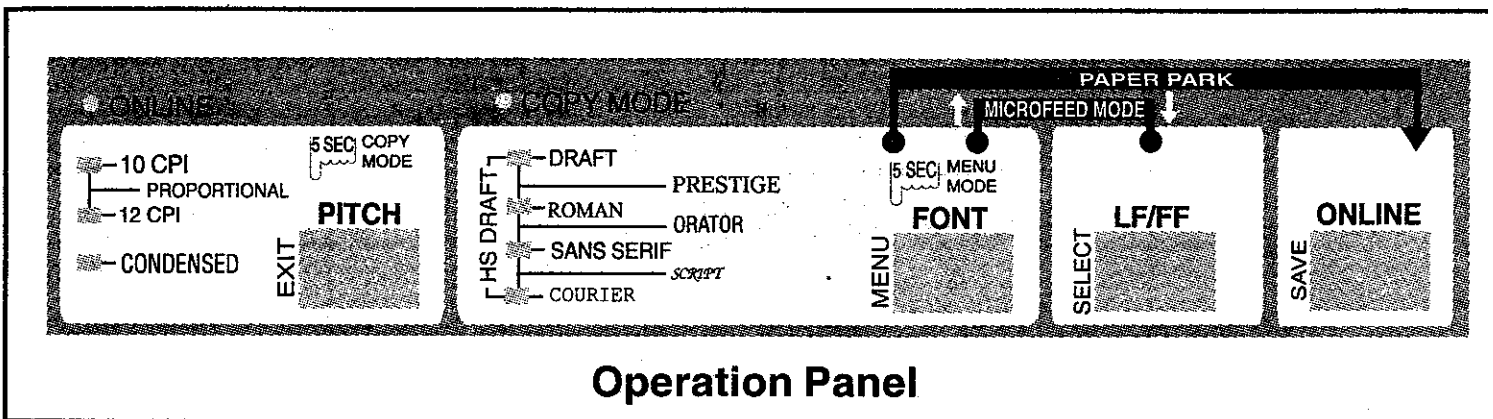

Function in the normal mode	Function in the Macro programming mode
LF/FF	SELECT (Select a field)
ONLINE	SAVE (Save the setting)
FONT	MENU (next record)
PITCH	EXIT (exit the MENU mode)

## MSP Series

### Selecting and Loading paper Paper Select Lever

- ▲ “FRIC” and “PIN” are the two positions.
- ▲ The “FRIC” is used to load single sheet paper.
- ▲ The “PIN” is used to load continuous paper.

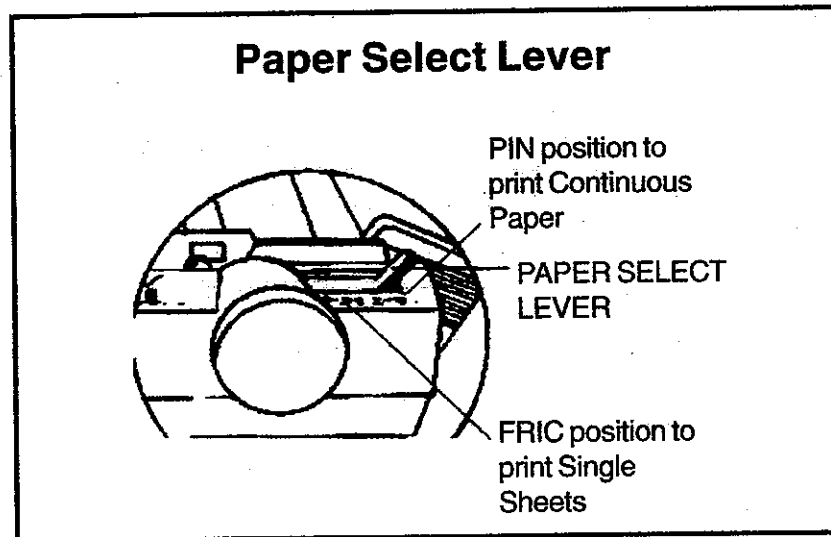

### Top of Form settings (TOF)

- ▲ Load the stationery in the tractor mode and press **LF/FF** switch such that paper detected and automatically loaded.
- ▲ Now park the paper by holding **FONT** and **ONLINE** switch.
- ▲ Press the **LF/FF** switc once, the paper will be loaded to the "TOP" position (TOP OF FORM POSITION)

- ▲ Press **ONLINE** switch to move it into **ONLINE** mode.
- ▲ Press **FONT** switch and **LF/FF** switch to enter into **TOF** settings or **MICROFEED** mode.
- ▲ Top of Form (**TOF** is the first printing position on the paper).
- ▲ Use Micro Line Feed (Forward - **FONT** switch) and (Reverse - **LF/FF** Switch) to adjust the **TOF** (Top of Form)
- ▲ Press **ONLINE** to save the settings.

## Tractor Feed Push Tractor

- ▲ The MSP printer comes with standard Push Tractor mechanism installed from the factory.
- ▲ Close the top cover.
- ▲ If the tractor is not already in push position, push the two release levers on the back of each end of the Tractor mechanism and place the mounting feet into the slots on the rear of the printer. Secure the Tractor unit and let go of the release levers; the Tractor will lock and now you can turn the paper feed knob to make sure the gears are turning properly.

## Tractor Select Lever

- ▲ Space the paper supports evenly between the adjustable tractors.
- ▲ Now load the paper from the rear side of the printer.
- ▲ Flip the locking levers forward and adjust the Tractors to approximate paper width.
- ▲ Place a stack of paper on a level surface behind the printer.
- ▲ Press the LF/FF switch to load the paper automatically

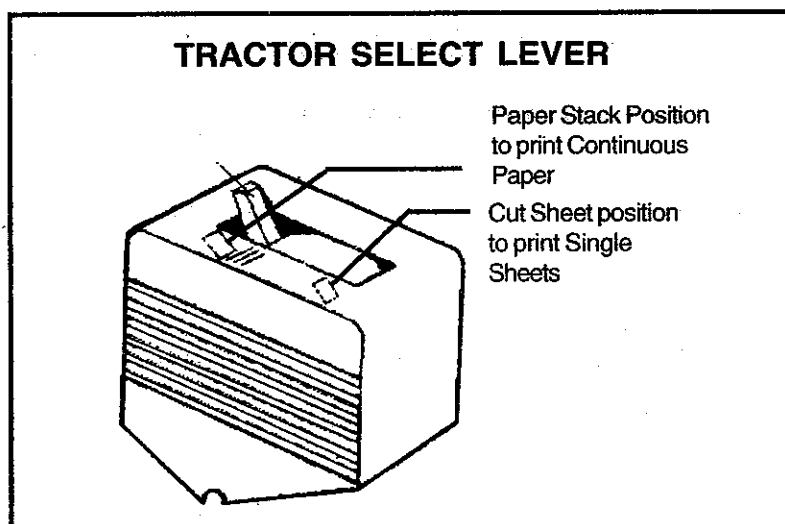

## Printing Continuous Stationery in Push Tractor Mode

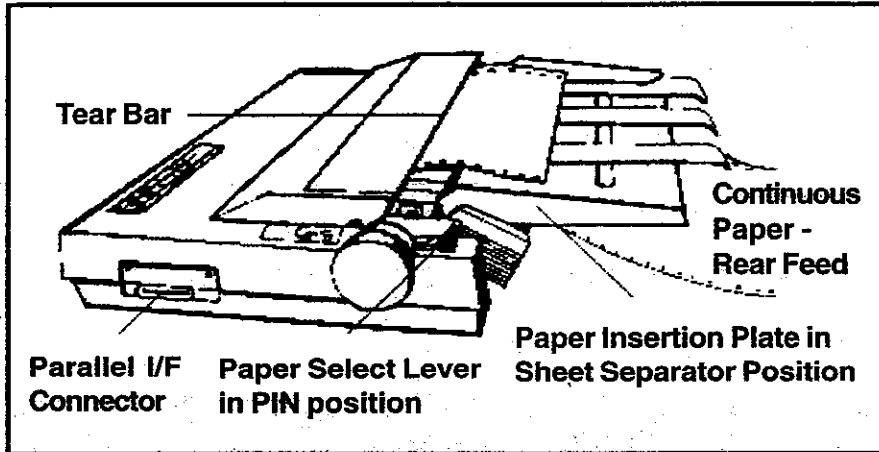

### Inserting Continuous Paper in Push Tractor

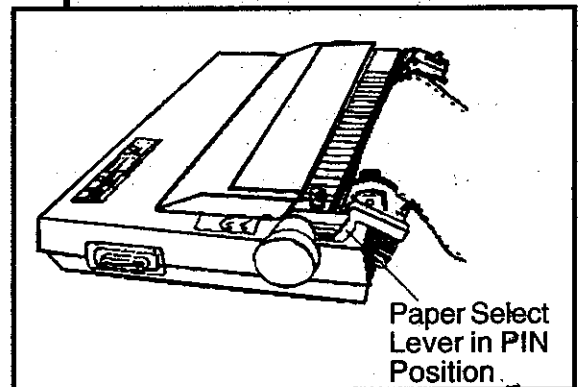

## *MSP Series*

---

### **Pull Tractor**

- ▲ Push in the two release levers on the back of each end of the Tractor mechanism and place the mounting feet into the slots on the top of the printer.
- ▲ Secure the Tractor unit on top of the printer and let go of the release levers - The tractor will lock into place.
- ▲ Install the paper supports and space them evenly between the adjustable tractors.
- ▲ Move the paper select lever to the **FRIC** position
- ▲ Flip the locking levers forward and adjust the tractors to the approximate paper width.
- ▲ Place a stack of paper on a level surface behind the printer.
- ▲ Bring the top sheet of the paper forward and insert it into the slot just behind the platen
- ▲ Turn the paper feed knob until the paper advances past the print head.
- ▲ Move the paper select lever to the PIN position.
- ▲ Adjust the paper left or right by sliding the Tractors.
- ▲ When the paper is positioned, lock the Tractors in place by flipping the locking levers towards the back.
- ▲ Turn the power switch **ON** to start printing.

(Refer to the Figure in the next page)

### Printing Continuous Paper with Tractor Unit in Pull Position

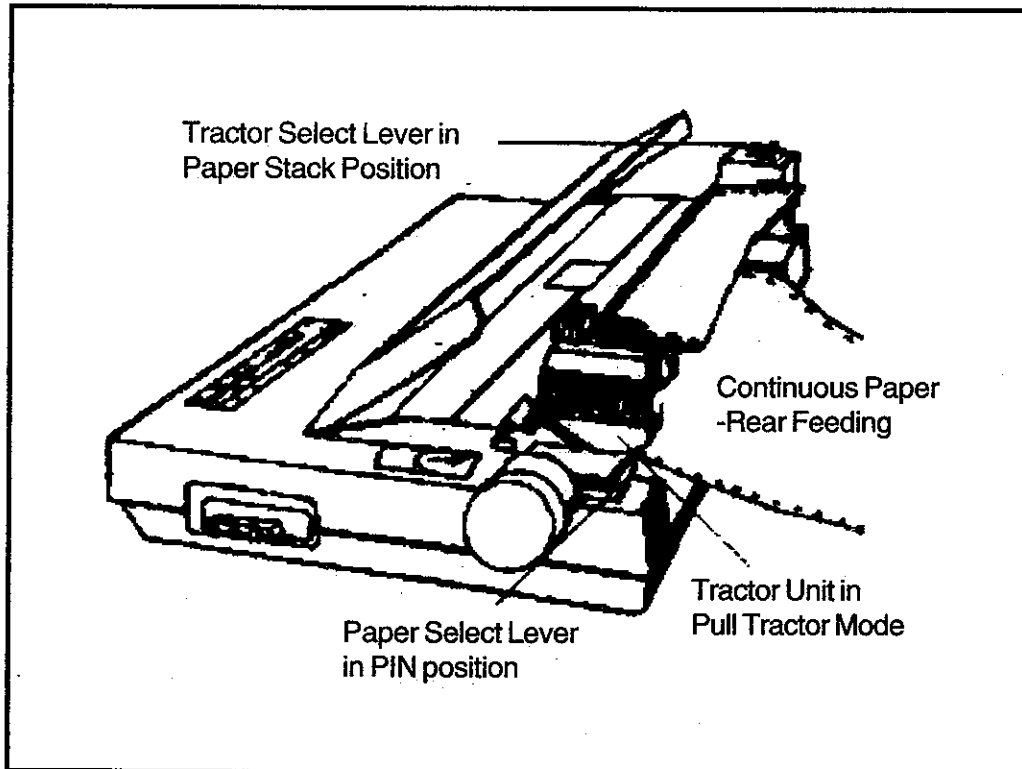



# MSP Series

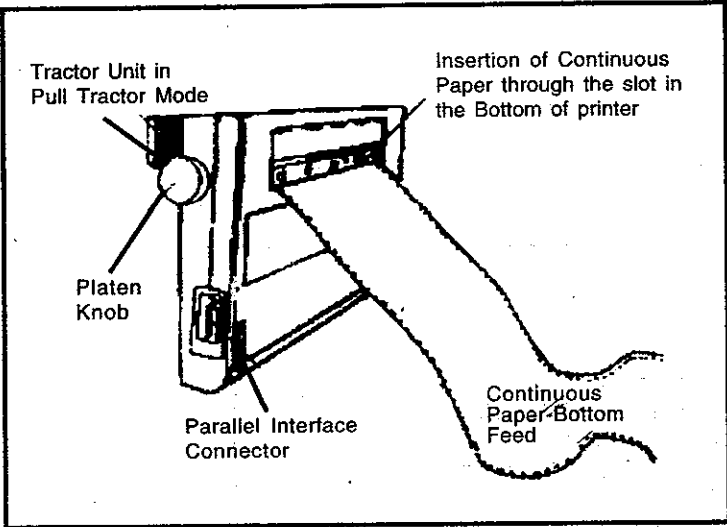

## Paper Insertion Bottom Feed

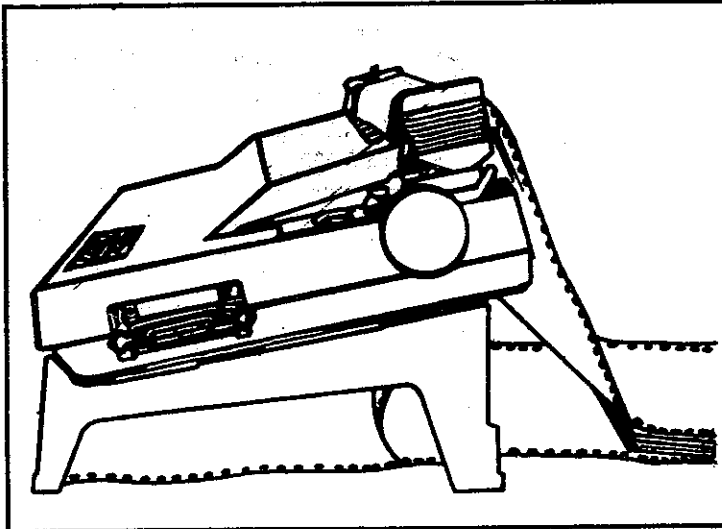

## Bottom Feed Paper path

- ▲ Ensure the Tractor is in Pull position.
- ▲ Turn OFF the printer power switch.
- ▲ Remove the top cover and rest the printer on its front side as shown in the figure.
- ▲ Insert continuous forms through the slot in the bottom of the printer. Pull the forms so that 4 or 5 inches extend out of the printer.
- ▲ Position the forms in the printer as far left as possible in order to activate the printer's paper sensor.
- ▲ Set the printer right-side-up.
- ▲ Open the tractor covers, position the continuous forms on the sprockets and close the covers.
- ▲ Ensure the paper is straight. Adjust the distance between the tractor, if necessary, by unlocking the lock levers and sliding the tractors until the paper is taut. Relock the levers.
- ▲ Move the paper select lever to the paper-stack position.
- ▲ Turn the paper feed knob until the next form is set to the correct starting-print position.
- ▲ Turn ON the printer power switch.

(Refer to the Figure in the previous page)

## Printing on Single Sheet

Single-sheet feeding allows you to print on Letter head and on other types of paper that are not available in continuous format (A4&A3 sheets).

- ▲ Ensure the Tractor is in Push position. MSP 3XX printer comes with the Tractor in push position.
- ▲ If you have loaded continuous paper, switch the printer '**OFF LINE**' and press the **FONT/ONLINE** to park the continuous paper.
- ▲ Move the paper select lever to the single-sheet position.
- ▲ Insert the single sheet into the paper guide, faced down, between the paper holder. Push the paper down gently to be sure it is all the way in.
- ▲ After a short pause, the paper automatically feeds into the printer and stops when it reaches the correct position to print the first line.
- ▲ Set the printer on line by pressing **ON LINE** switch.

(Refer to the Figure in the next page)

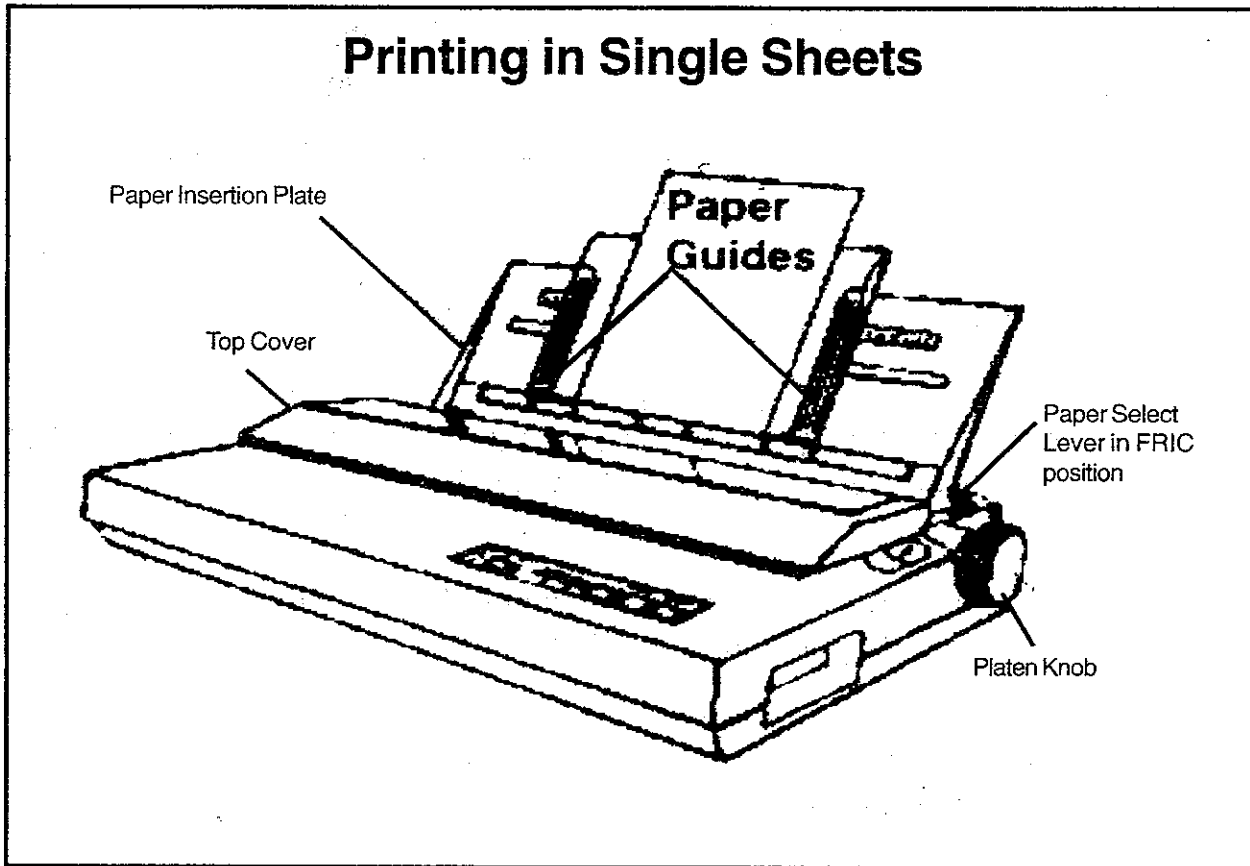

## Helpful Hints



Use only high density MSP ribbons for 24 Wire Printers. Use of improper ribbon may damage the print head and invalidate the warranty.



If you are replacing a ribbon be sure the printer is **OFF** and the print head is cooled.



Carefully read the instructions for correct ribbon placements. Improper placement can cause smudged printing and may jam the ribbon.



**ONLINE** is the printer's normal operating mode. When the printer is **ONLINE** can receive data from your computer and print. When the printer is **OFFLINE** stops printing and responds only to control-panel instructions, such as moving paper.



To completely cancel the print job, first cancel the job in your software application. Then clear the data from the print buffer.



Because of advanced paper-handling features it is seldom necessary to turn paper feed knob. More frequently turning the paper feed knob causes misalignment. Use the Control panel instead.



Paper tear off, top-of-form adjustment and paper parking are not available when using tractor in **PULL** mode.



Do not rotate the **PLATEN KNOB** when the printer is in power **ON** condition.



The top margin is usually set by your software. You may not need to change the top-of-form setting very often.



For serial interface connection you need to install an optional serial interface board. Please contact your nearest **TVS-E** dealer. Serial interface cable comes with a board.



If the printer is used heavily or in a dusty environment consult **TVS-E** service centre for advice on periodic cleaning and lubrication.

# MSP Series



## Product Specifications - MSP 3XX Series

	MSP 330		MSP 335		MSP 345	
<b>Print Head</b>	24 Wire					
<b>Print Width</b>	80 Col.		136 Col.		136 Col.	
<b>Print Head life</b>	400 Mn. Strokes / Wire				200 Million Strokes / Wire	
<b>Print Speed (cpi)</b>	10	12	15	10	12	15
Super Speed Draft (cps)	-	-	-	360	-	-
High Speed Draft (cps)	300	-	-	300	-	-
Draft Speed (cps)	200	240	300	250	300	375
Letter Quality (cps)	66	80	100	83	100	125
<b>Print Method</b>	Impact Dot Matrix with 24 wire Print Head Bi-Directional Logic seeking					
<b>Character Matrix (cpi)</b>	10		12		15	
Draft	12H X 24V		10H X 24V		12H X 16V	
High Speed Draft	10H X 24V		-		-	
Letter Quality	36H X 24V		30H X 24V		24V X 16V	
<b>Fonts</b>	Draft & High Speed Draft, Roman, Sans Serif, Courier, Prestige, Orator, Orator-S, Script, Script-C, OCR-B, Scalable Roman, Sans Serif (8 to 40 Points)					
<b>Paper Handling</b>	Friction/Tractor (Convertible Push & Pull Tractor)					
Paper Feed Method	Friction/Tractor (Convertible Push & Pull Tractor)					

## Product Specifications - MSP 3XX Series

	MSP 330	MSP 335	MSP 345
Paper Path Cut Sheets Continuous Sheets	Top / Rear / Bottom Top Rear / Bottom		
<b>Copy Capability</b>	1+3 with Carbon (Max. 0.3 mm)		
<b>Paper Size</b> Width Weight	4.5" ~ 10" 14 ~ 26 lbs	4.5" ~ 15" 14 ~ 26 lbs	
<b>Ribbon Cartridge</b> Tyre Life Expectancy	High Density - Disposable Cartridge - MSP Tyre 24 Wire 3 Million Characters		
Length	13 Mtrs MSP 24W-80 col.	18 Mtrs MSP 24W-136 col.	
<b>Interface</b> Standard Optional	Centronics - Bidirectional Parallel (IEEE - 1284A complaint) RS232 C-Serial		
Input Data Buffer Emulation	40 KB Epson ESC/P2, IBM Pro printer XL24e		
Environment	+5 Deg to +45 Deg Centigrade		
Voltage	150 VAC ~ 270 VAC		
Reliability	6000 POH		
<b>Physical</b> Dimension (WxDxH) Weight	433 x 379 x 147 5.7 kg	608 x 375 x 147 7 kg	

**\*\* Specifications are Subject to change without prior notice**

*Quick Reference Manual*