

Copyright

The copyright/ownership of this document is and will remain ours. The document must not be used without our authorization or brought to the knowledge of a third party. TagMaster AB.

Disclaimer

The information in this document is subject to change without notice. While the information contained herein is assumed to be accurate, TagMaster AB assumes no responsibility for any errors or omissions.

FCC ID: M39LRXX

This device complies with part 15 of the FCC Rules.

Operation is subject to the following two conditions:

(1) This device may not cause harmful interference, and
(2) This device must accept any interference received,
including interference that may cause undesired
operation.

NOTE: This equipment has been tested and
found to comply with the limits for a Class
A digital device, pursuant to part 15 of the
FCC Rules. These limits are designed to provide
reasonable protection against harmful
interference when the equipment is operated
in a commercial environment. This equipment
generates, uses, and can radiate radio
frequency energy and, if not installed and
used in accordance with the instruction
manual, may cause harmful interference to
radio communications. Operation of this
equipment in a residential area is likely to
cause harmful interference in which case the
user will be required to correct the interference
at his own expense.

Caution

Information to user.

Changes or modifications not expressly
approved by the party responsible
for compliance could void the
user's authority to operate the equipment.

TABLE OF CONTENTS

1	ABOUT THIS DOCUMENT.....	5
1.1	Introduction.....	5
1.2	Audience	5
1.3	Definitions.....	5
1.4	References.....	6
1.5	Revisions.....	6
2	SAFETY INSTRUCTIONS	7
2.1	General.....	7
2.2	Installation	7
3	SYSTEM COMPONENTS	9
3.1	Readers.....	9
3.2	ID Tags.....	9
4	ENVIRONMENTAL CONSIDERATIONS	10
4.1	General.....	10
4.2	Electromagnetic immunity	10
4.3	Temperature.....	10
4.3.1	Readers	10
4.3.2	Tags	10
5	MECHANICAL INSTALLATION.....	11
5.1	General.....	11
5.2	Readers.....	11
5.2.1	Mounting	11
5.2.2	Cables.....	11
5.3	ID-Tags.....	11
5.4	Accessories	12
5.5	Typical installations	13
5.5.1	Single lane identification	13
5.5.2	Multi lane identification.....	13
5.5.3	How to handle and mount the tag.....	13
6	ELECTRICAL INSTALLATION	14
6.1	General.....	14
6.2	Connection diagrams	16
6.2.1	Single Communicator connection using port A for RS232C.....	16
6.2.2	Single Communicator connection using port B for RS232C.....	16
6.2.3	Direct Communicator multipoint connection using port B for 2-Wire RS485.....	17
6.2.4	Digital I/O connections (example).....	18
6.2.5	Power supply connection	19
6.3	Hardware adaptation.....	19
6.3.1	Jumper connections.....	19
6.3.2	Adaptation of the S1500 or S1503 to 12 VDC power supply	19
7	CABLES.....	20
7.1	Power supply.....	20
7.2	Digital I/O and DTMF.....	20
7.3	RS232	20
7.4	RS485	20
7.4.1	2-Wires interface.....	20
7.4.2	4-Wires interface.....	20
8	START-UP	21

8.1	General.....	21
8.2	Inspection	21
8.3	Verifying communication	21
8.3.1	Serial host communication.....	21
8.3.2	Communicator - Tag communication.....	21
8.3.3	Digital I/O - communication with external devices	22
9	TROUBLE SHOOTING.....	23
9.1	An S1500/S1503 communicator seems not to read Tags	23
9.2	Unsuitable interface converters.....	23
9.3	Interference	23
9.4	Using wrong address	23
9.5	Forgetting the free-wheel diode across inductive loads.....	23
9.6	Using different data speed in the Tag(s) and in the Communicator(s)	23
9.7	Using an unsuitable power supply	24

1 ABOUT THIS DOCUMENT

1.1 Introduction

The basic elements of a TagMaster identification system are the electronic ID-Tags (e.g. S1251), the Reader/Communicator (e.g. S1500), and possibly a host computer.

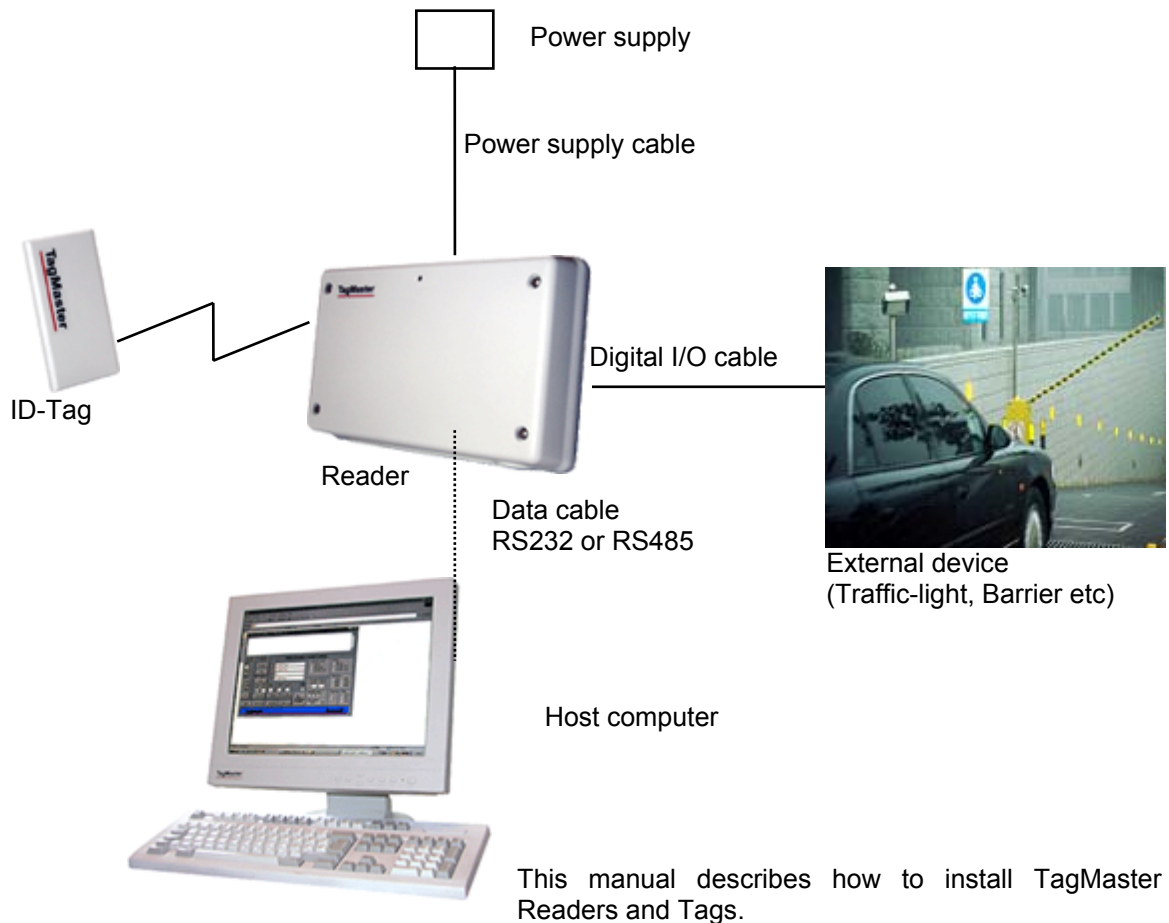

This manual describes how to install TagMaster Readers and Tags.

1.2 Audience

The intended audience for this document is system integrators, installation engineers, contractors or the like who have the task to install and commission TagMaster identification systems. The audience is expected to have adequate experience and education in the field of installation and commissioning of control and identification systems and to be qualified for electrical installations.

1.3 Definitions

- Communicator** Device (e.g. S1500) used to read and write Tags in the TagMaster system.
- ConfiLib** The TagMaster Library Software (ConfiLib) is the uniting name of the device drivers that are included in all S1500/S1501/host C-language software modules.

ConfiTalk	Standard communication protocol. Used by Pyramid and Solid. Included in ConfiLib.
Host	IBM PC or compatible used as master computer in a TagMaster system.
Pyramid	Pyramid is the <i>S1500</i> standard software delivered from factory. S1500 with Pyramid is capable of taking decisions on its own when a Tag has been read or when a movement has been detected. Refer to the S1500 datasheet for further details.
Solid	Solid is the <i>S1501</i> and <i>S1566</i> standard software delivered from factory. This software receives ConfiTalk commands on the serial port and executes them. This is the same as the ConfiTalk only mode of the S1500.
Tag	ID-carrier (e.g. <i>ScriptTag S1251</i>) in the TagMaster system, which is read/writable via, microwaves, using a Communicator.

1.4 References

Communicator S1500&S1501 data sheet	DS1500
Communicator S1503&S1504 data sheet	DS1503
Communicator S1513&S1514 data sheet	DS1513
ScriptTag S1251 data sheet	DS1251
ScriptTag HD S1450 data sheet	DS1450
ScriptTag HT S1350 data sheet	DS1350
MarkTag S1255 data sheet	DS1255
MarkTag HD S1455 data sheet	DS1455
Card holder WinFix S1951 data sheet	DS1951
Card holder CardKeep S1953 data sheet	DS1953
Mounting bracket S1952 data sheet	DS1952
RS232/RS485 converter S1942	DS1942
TagMaster Programmer's Guide	510211

1.5 Revisions

<u>Issue</u>	<u>Date</u>	<u>Description</u>
01	971211	First issue
02	980623	Second issue
03	030506	Third issue
04	040916	New layout
04	041207	Minor corrections
05	060202	Modified for revision 5 (new RF.board)

2 SAFETY INSTRUCTIONS

This chapter gives an overview of necessary safety precautions for the TagMaster system.

2.1 General

This Installation Manual shall be carefully read before any installation works is performed. Special attention shall be paid to this page and the statements in boxes throughout the manual.

The contents of this document are not binding. If any significant difference is found between the product and this document, please contact TagMaster AB for further information

We reserve the right to modify products without amending this document or advising the user.

We recommend using personnel authorised by TagMaster for all installation, service and repair and the use of TagMaster genuine spare parts. TagMaster AB will not otherwise assume responsibility for the materials used, the work performed or any consequences of the same.

Check the contents of the shipment for completeness and possible damage. If the contents are incomplete or damaged, a claim should be filed with the carrier immediately and the TagMaster Sales or Service organisation or the TagMaster representative should be notified in order to facilitate repair or replacement of the equipment.

The equipment described in this manual is designed to be used by properly trained personnel only. Qualified personnel who are aware of the hazards involved and who are qualified for electrical installations shall carry out installation, adjustments and maintenance of the exposed equipment.

For correct and safe use of this equipment, it is essential that both operating and service personnel follow generally accepted safety procedures in addition to the safety precautions specified in this manual.

Specific warning and caution statements are used throughout this manual.

CAUTION is used to indicate correct operation or maintenance procedures in order to prevent damage to, or destruction of the equipment or other property.

WARNING indicates a potential danger that requires correct procedures or practices in order to prevent injury to personnel.

Whenever it is likely that safe operation is impaired, the equipment must be made inoperative and secure against unintended operation. The appropriate servicing authority must then be informed.

2.2 Installation

- Before any other connection is made, the equipment shall be mounted so that the metallic chassis is connected to protective ground.

WARNING Interruption of the chassis connection with protective ground can make the equipment dangerous if it is connected to a defective power supply.

- The power supply used to provide the equipment with 24 or 12 VDC must comply with all relevant safety regulations. It must also be made for connection to the local mains voltage and be able to provide the necessary power without producing excessive heat.

- Fuses shall only be renewed by a qualified person who is aware of the risks involved. The use of repaired fuses is prohibited.
- Capacitors inside the equipment can hold their charge even if the equipment has been disconnected from all voltage sources.
- All PCB's removed from the equipment must be adequately protected against damage and all normal precautions regarding the use of tools must be observed.
- The equipment must be disconnected from all voltage sources before any installation or service work is made.

CAUTION Damage may be the result if;

- The equipment is switched on when parts are removed from the PC board.
- A PCB is removed within one minute after switching off the equipment.

3 SYSTEM COMPONENTS

The hardware of a TagMaster system is described briefly below.

3.1 Readers

The S1500/S1503/S1513 Communicator is a device for reading and writing ID Tags using 2.45 GHz microwaves. It is powered with 24 VDC but can be adopted for 12 VDC. The S1500 has built-in antennas for communication with the Tags and various serial interfaces for communication with a host computer. The Communicator also provides a movement detection function that can detect moving objects in the reading zone (also non-Tagged objects). One hundred frequency channels are available. The microprocessor is a 16-bit Hitachi H8/534. The S1500 is equipped with Flash EEPROM for program code and database. Designed for different installations, the S1500/S1503 comprises a wide range of I/O devices, including relays, optocouplers, DTMF receiver, LED, buzzer and a control panel. It also has a real-time-clock, 2/4Wire RS485 interface and a connector for an optional board.

The S1501/S1504/S1514/S1566 is a less advanced Communicator and is powered by 12 VDC only. It has no database memory, no real-time-clock, no optional card connector and the second serial interface is only 2Wire RS485. Refer to the datasheets for details.

3.2 ID Tags

An ID-Tag is a device carrying ID information that can be read at a long distance using microwaves. Versions that can be read at a distance of up to 6 meters with the Communicator S1503/S1504 are available. The actual reading range depends on the Communicator type. Also different shaped versions of the tags are available. Some have the shape of a credit card but is slightly thicker. Each Tag has its own unique 8-digit mark. It is possible to read many Tags concurrently. To maintain the information, to get the long reading range and the high communication speed, a lithium battery cell is used. The life of the cell depends on the Tag type but is typically 5 - 10 years and independent of how often the Tag is used. Certain types of Tags (e.g. *ScriptTag S1251*) can also be written by the user. The Tags then have a static RAM memory array that can be configured for different memory sizes; 14, 154 or 574 bits (32 bit checksum not included in these figures). Refer to the Tag (e.g. S1251 or S1450) data sheet for details.

4 ENVIRONMENTAL CONSIDERATIONS

4.1 General

Microwaves have, during more than a decade, proven to be the most reliable technology for identification systems. In particular, microwaves are unaffected by the normal electromagnetic background noise found in industries and elsewhere. They also form a base for products that have to withstand other rough environmental conditions as high temperatures, chemicals, shock and vibrations

4.2 Electromagnetic immunity

The TagMaster system has been tested and approved, in operation, according to the IEC standards. This guarantees trouble-free operation in demanding electromagnetic environments.

Electromagnetic interference on the microwave link

Industrial noise is typically present in the KHz and low MHz frequency band. The TagMaster system is only receptive for frequencies closed to 2.45 GHz so typical industrial noise will not affect the microwave communication. Transients from spot-welding equipment or from switching on other welding equipment, soldering machines and fluorescent lamps may produce short pulses around 2.45 GHz. However, since the TagMaster system, if interfered, will retransmit the entire message very fast there is in most cases ample time for a re-transmission. If strong microwave fields, from for instance microwave dryers, can be suspected, TagMaster AB should be consulted.

Electromagnetic interference in cables

By selecting a suitable communications interface, using specified cables and proper shielding and grounding, optimum communication reliability is ensured.

4.3 Temperature

4.3.1 Readers

In most applications, normal convection cooling is enough. In applications where heat is generated close to the Communicator, forced cooling or heat shields may be necessary.

4.3.2 Tags

TagMaster tags are available for operation in various ambient temperatures ranging from -40°C up to 85°C (refer to the data sheets). The specified reading range is valid for normal ambient temperature conditions. If reading range is critical and the intended operating temperature deviates from normal ambient temperature TagMaster AB should be consulted.

5 MECHANICAL INSTALLATION

This chapter describes the procedure of installing the TagMaster units mechanically. It is assumed that the location of Readers and Tags are specified, and the communication distances and movement speeds are considered during the project-planning phase. Likewise it is assumed that the project planning is well documented.

5.1 General

Microwaves penetrate wood, dirt, paint, plastic, and most other non metallic materials. The TagMaster system employs circular polarisation and can therefore also often be used when metal surfaces are in the vicinity of the antenna and Tag, especially if the Tag is moving. In such cases however, adjustment of the Tag/Communicator position and distance may be necessary to find the best position. Always combine this with tests to verify that the installation will work.

5.2 Readers

5.2.1 Mounting

- Position the Communicator with the cable entries pointing downwards and so that the device is easily accessible for service.
- Mount the Communicator in an adjustable holder. (ComFix S1952 or PoleFix S1956 is recommended) and direct it so that it's lobe beam covers the position of the Tag(s).
- If Tags are to be mounted in car wind screens it is recommended to mount the Communicator approximately 2 meters up and tilted down for best performance. Refer to the typical installation illustrations in section 5.5.

5.2.2 Cables

To keep the sealing on a high level the Communicator should be mounted against a flat surface like for instance a mounting plate. It should be fastened on the mounting plate using the mounting holes located in the corners of the Communicator back panel. If the sealing level of IP 54 must be kept, then the cables must enter the Communicator using standard electrical feed through bushings.

5.3 ID-Tags

The front side of the ID-Tags must be oriented towards the front side of the Communicator. The backside of the tag has a type label on it. To get the maximum communication range the front surface of the Tag should be in parallel with the front side of the Communicator. If the Tag is miss-aligned relative to the front side of the Communicator, the communication range is reduced. Refer to the actual product datasheets for details.

Due to TagMaster's circular polarisation the rotational orientation of the Tag relative the Communicator is uncritical. The Tags can be mounted on any flat surface. If it is to be expected

that the mounting surface material, when warmed up, can expand in a different way than the Tag, the Tag must be mounted in such a way that the material expansion does not damage the Tag.

When screwing the Tags directly on to a surface, the screw must **not** be secured by pulling it until it does not move anymore. Instead a threaded hole should be used and the screw should be pulled until the Tag is just fixed. Then the screw should be secured using a washer and nut from behind.

For the credit card shaped Tags S1251 and S1255, TagMaster AB offers holders for use in vehicle windows or for personal carrying. (WinFix S1951 and Cardkeep S1953). For permanent mounting of the Tag in a vehicle window the CardTape S1954 is recommended.

5.4 Accessories

The following TagMaster accessories are available:

<u>Product</u>	<u>Art.No</u>	<u>Description</u>
RS485 Converter	S1942	Interface converter for RS232C - RS485 2Wires
WinFix	S1951	Tag holders for vehicle window mounting
CardTape	S1954	Tag tape for fixed mounting on vehicle window.
CardKeep	S1953	Tag holders for personal carrying
ComFix	S1952	Adjustable Communicator holder
PoleFix	S1956	Pole fastening bracket

5.5 Typical installations

5.5.1 Single lane identification

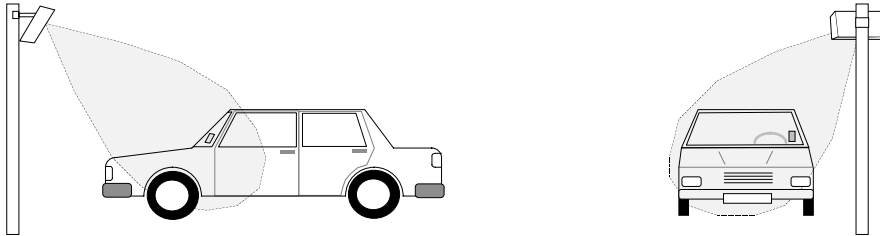

5.5.2 Multi lane identification

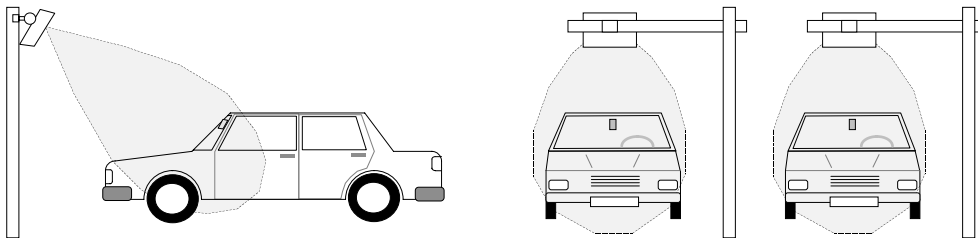

For optimum performance:

- Keep Tag and Communicator surfaces as parallel as possible
- Distance Tag - Communicator < 70% or less of maximum reading range, refer to the actual data sheet
- The windscreen might reduce maximum reading range with up to 0.5 meter

5.5.3 How to handle and mount the tag

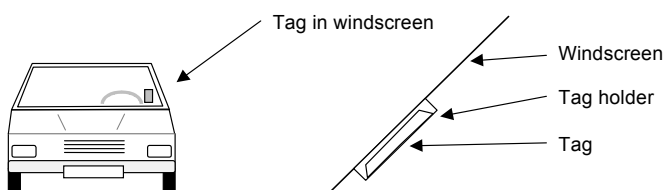

The tag should be mounted on the inside of the windscreen in a tag holder (WinFix). Note that the front side of the tag inside the holder should face the reader.

6 ELECTRICAL INSTALLATION

This chapter describes the procedure of electrically installing TagMaster Readers. Three basic connection-types are described:

- Host connection
- Digital I/O connection
- Power supply connection

It is assumed that the location of Readers and Tags are specified, and that cable paths and cable types are considered during the project-planning phase. Likewise it is assumed that the project planning is well documented.

6.1 General

To make connections to the Communicator the cover must be removed. Terminal blocks for connection of the external cables and jumpers for hardware adaptation are located under the cover according to following illustration of an S1500 communicator:

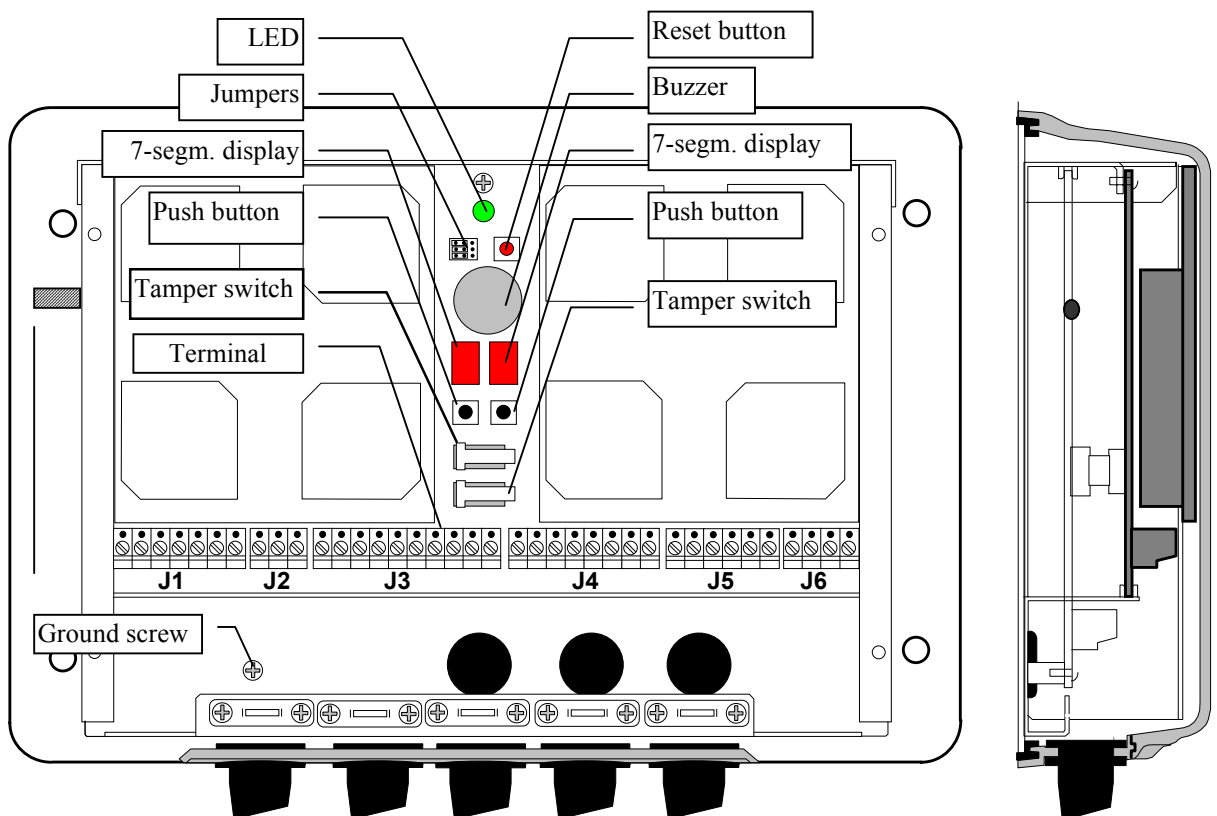

Connections to the Communicator are made using the terminal blocks J1 - J6.

Please note that the 7-segm. display, the buzzer and the upper tamper switch are components not present in the S1501. The use of these, as well as the use of the push buttons, is communicator software dependent and therefore described in the communicator software documentation.

Screened cables shall be used with screens clamped according to the figure below.

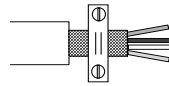

The electrical data and the connection diagram are shown below

Notes: The S1500/S1503 supports 24VDC power supply and can be adopted for 12VDC.
The S1501 supports 12VDC power supply only.
The S1501 does not support RS485-4Wire interface

DTMF (Terminal block J1)

2-wire interface to receive a dual tone signal and to power a DTMF device.

Parameter	Min	Max	Unit
Line volt. @ 10 mA	4.1	4.5	V
Tone level	-26	0	dBm

J1:	1	LED 1
	2	LED 2
	3	GndLED
	4	SDTMF
	5	RinDTMF
	6	Tamp a
	7	Tamp b

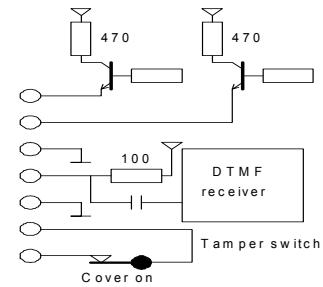

RS 232 - host and terminal (Terminal block J2)

Default: 9600 bps, 8 bits, no parity, 1 stop bit, ConfiTalk address 1

Parameter	Min	Max	Unit
Baud rate	1.2	19.2	kbits/s
Data bits	7	8	bits
Stop bits	1	2	bits
Parity	no - odd - even		

J2:	1	Tx232a
	2	Rx232a
	3	Gnd 232a

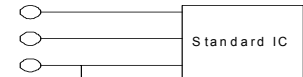

RS 485 - host (Terminal block J3)

Full (4 wire) or half duplex (2 wire). Default: 9600 bps, 8 bits, no parity, 1 stop bit, ConfiTalk address 1

Parameter	Min	Max	Unit
Baud rate	1.2	38.4	kbits/s
Data bits	7	8	bits
Stop bits	1	2	bits
Parity	no - odd - even		

J3:	1	Tx232b
	2	Rx232b
	3	Gnd 232b
	4	CGnd
	5	Tx-/Rx-485
	6	Tx+/Rx+485
	7	Gnd485t
	8	Rx485-
	9	Rx485+
	10	Gnd485r

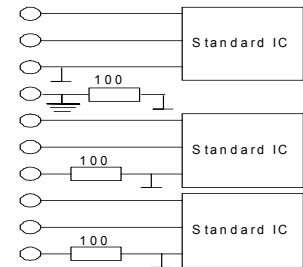

Open collector outputs (Terminal block J4)

Parameter	Min	Max	Unit
Allowed volTage	1	30	V
Sink current Out 1	0	500	mA
Sink current Out 2	0	100	mA

J4:	1	Outspl1
	2	Out 1c
	3	Out 1e
	4	Out 2c
	5	Out 2e
	6	R1c
	7	R1b
	8	R1m

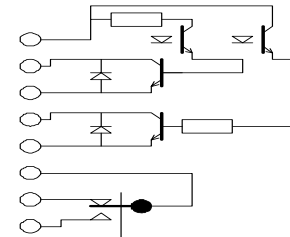

Relay (Terminal block J4)

Parameter	Min	Max	Unit
Switch current		2	A
Switch volTage DC		220	V
Switch volTage AC		125	V
Switch power		50	W

J5:	1	In 1a
	2	In 1c
	3	In 2a
	4	In 2c
	5	In 3a
	6	In 3c

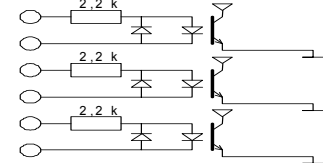

Optocoupler inputs (Terminal block J5)

Parameter	Min	Max	Unit
High volTage	2.4	30	V
Low volTage	0.0	0.2	V

J6:	1	Spl 1
	2	Rtnspl 1
	3	Spl 2
	4	Rtnspl 2

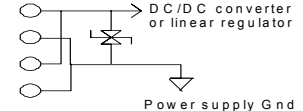

Power (Terminal block J6)

Parameter	Min	Max	Unit
24VDC Supply volTage	20	28	V
12VDC Supply volTage	10	14	V
Consumption 24V		150	mA
Consumption 12V		500	mA

6.2 Connection diagrams

6.2.1 Single Communicator connection using port A for RS232C

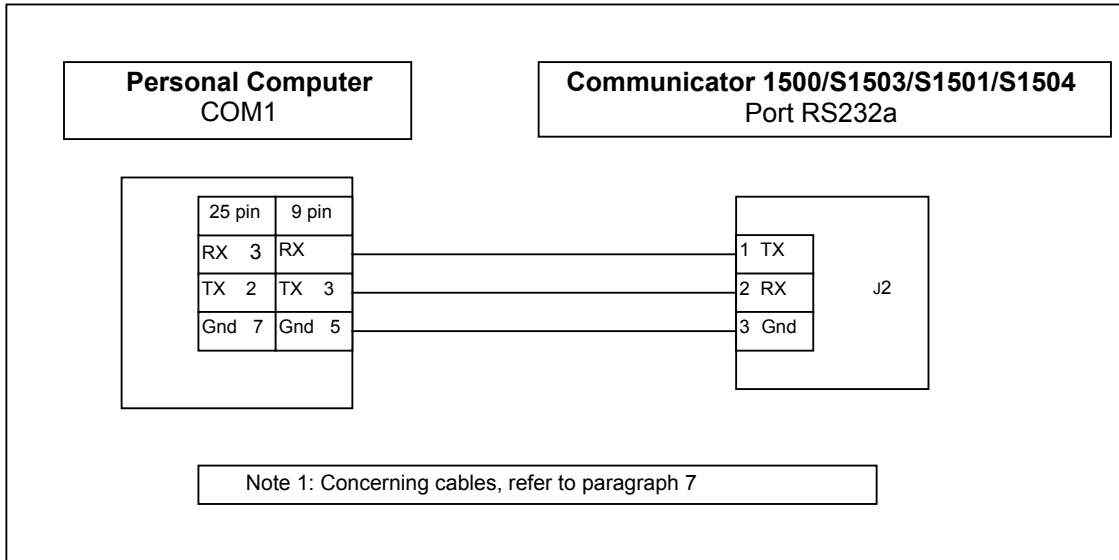

6.2.2 Single Communicator connection using port B for RS232C

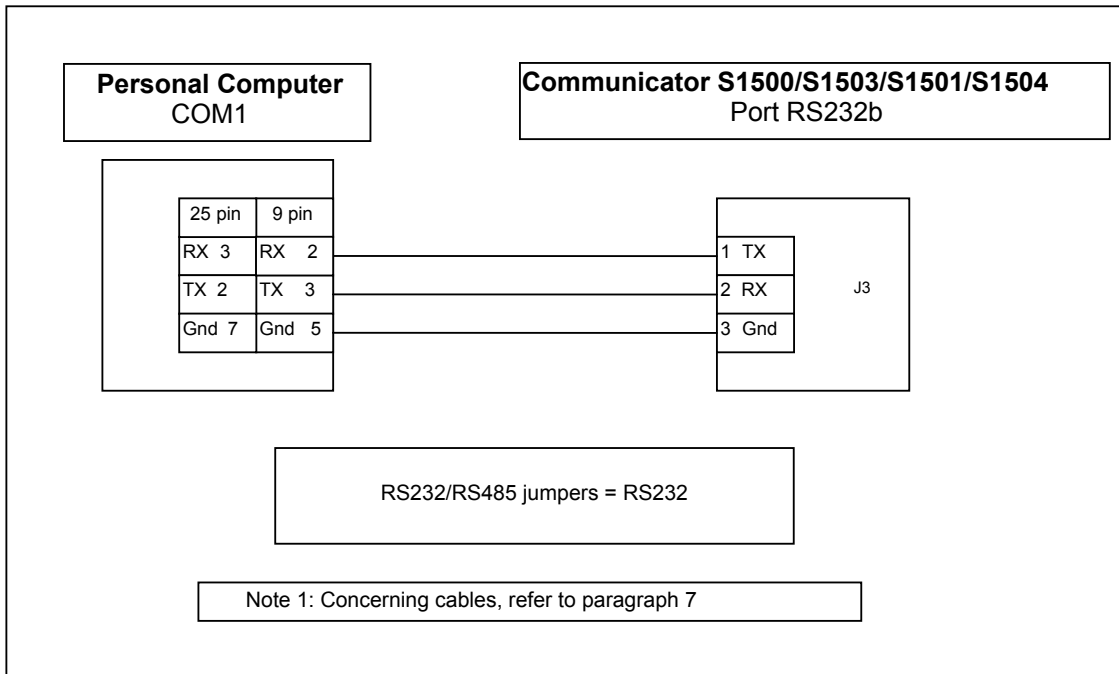

6.2.3 Direct Communicator multipoint connection using port B for 2-Wire RS485

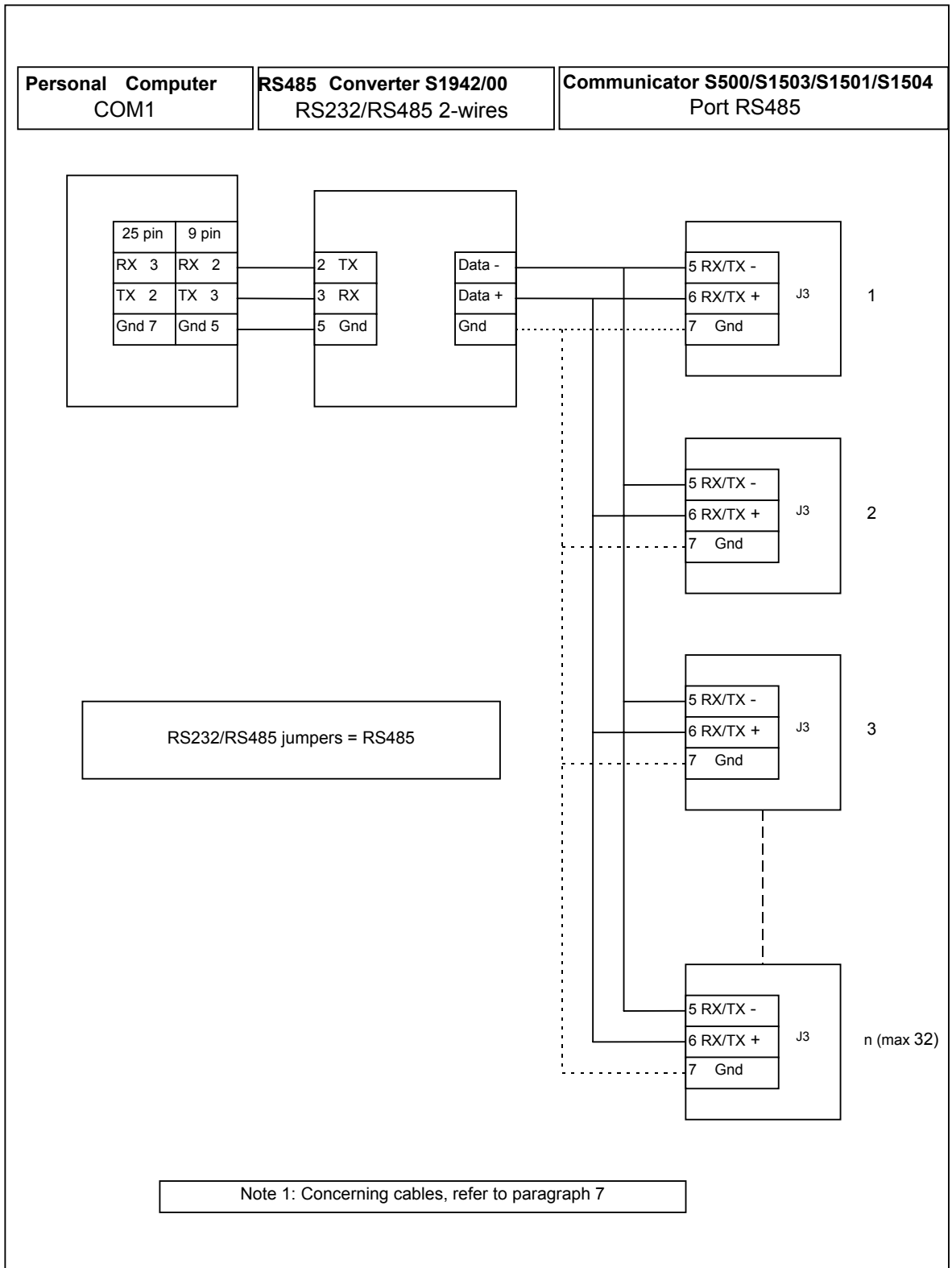

6.2.4 Digital I/O connections (example)

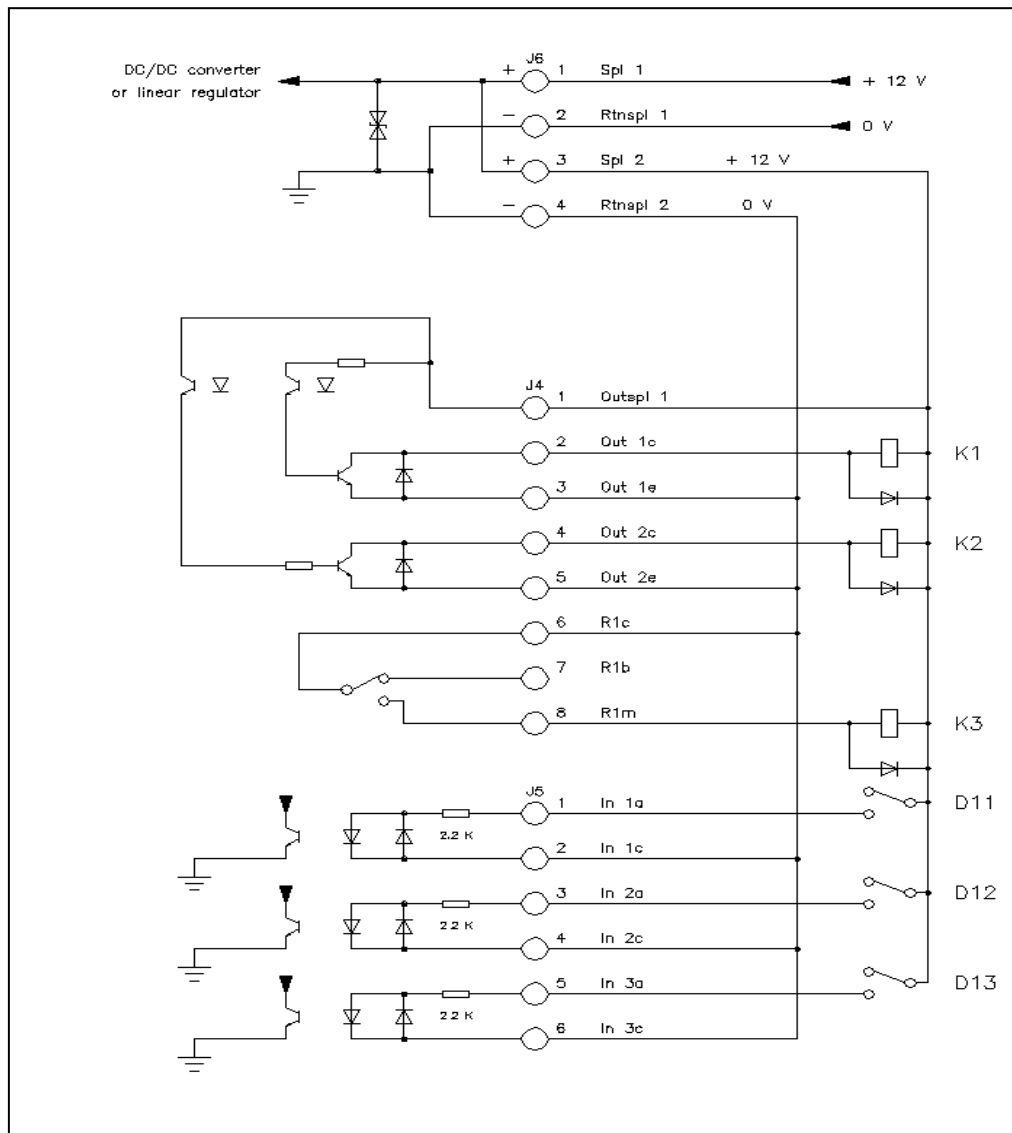

- | | | |
|-----------------------|--------------------------|-------------------------------|
| Optocoupler inputs: | ON = from 2.4 to 30 VDC | OFF = from 0.0 to 0.2 VDC |
| Optocoupler output 1: | Voltage from 1 to 30 VDC | Sink current from 0 to 500 mA |
| Optocoupler output 2: | Voltage from 1 to 30 VDC | Sink current from 0 to 100 mA |
| Relay output: | Switch current: 2 A | Switch voltage: 220 VDC |
| | | Switch voltage: 125 VAC |
| | | Switch power: 50W |

CAUTION

Omission of the protective free-wheel-diodes across K1, K2 and K3 may damage the Communicator.

6.2.5 Power supply connection

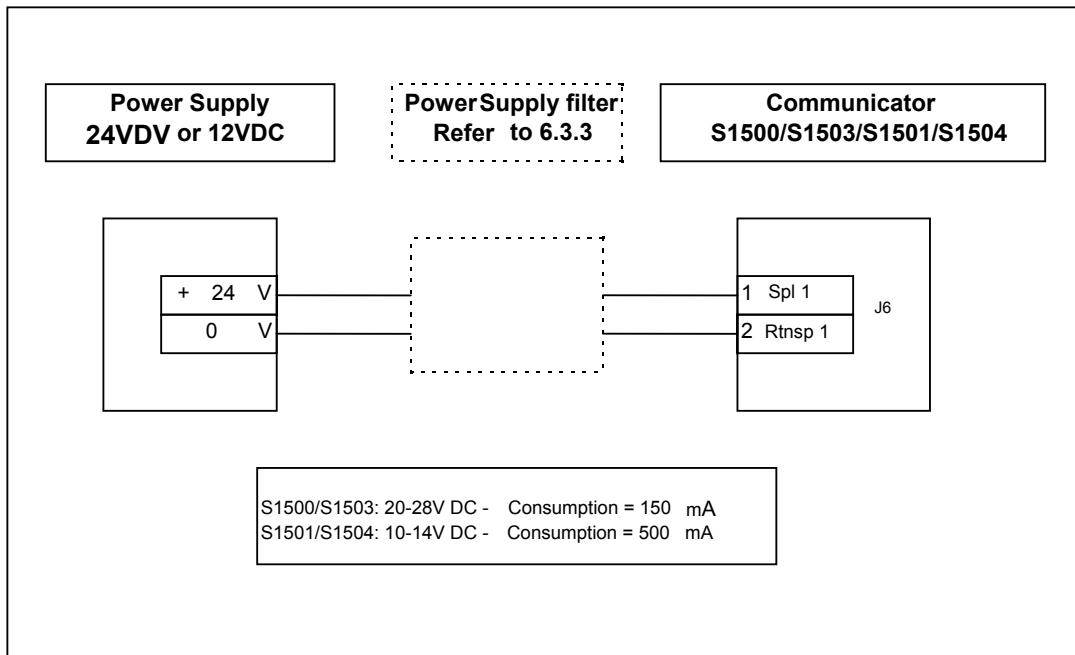

6.3 Hardware adaptation

This section describes how to set jumpers and how to adapt the S1500 or S1503 for 12VDC

6.3.1 Jumper connections

There are jumpers for selecting if port B should be configured as RS232 or RS485 and if the RAM backup battery shall be connected. Se figure below.

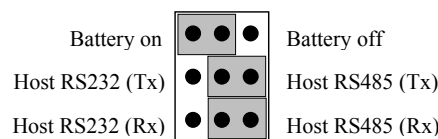

6.3.2 Adaptation of the S1500 or S1503 to 12 VDC power supply

CAUTION

This must be done by properly trained personnel only

Under the rightmost antenna, additional jumpers are available for setting the Communicator for power from a 12 or 24 VDC power supply. Marking on the PC boards indicate how to set these jumpers. The factory setting is 24VDC.

7 CABLES

7.1 Power supply

Cable specification:	
AWG	0.5 mm ²
Number of wires	2
Voltage rating	300 V
Temperature rating	+80°C
Recommended external diameter	> 5 mm
Maximum length	100 m

7.2 Digital I/O and DTMF

Cable specification:	
AWG	0.5 mm ²
Number of wires	Application dependent
Voltage rating	300 V
Temperature rating	+80°C
Recommended external diameter	> 5 mm
Maximum length	100 m

7.3 RS232

Cable specification according to EIA RS232C

Recommended type: Belden 9184 or Belden 9502

7.4 RS485

Cable specification according to EIA RS485

7.4.1 2-Wires interface

Recommended type: Belden 9841

7.4.2 4-Wires interface

Recommended supplier: Belden 9841

8 START-UP

8.1 General

After having completed the physical installation as described in previous sections, a systematic check of the installation and system performance should be carried out.

This work can be divided into two parts: **inspection** and **performance verification**.

When something does not work as expected the tips in paragraph TROUBLE SHOOTING may be valuable.

8.2 Inspection

- Ensure that there are no metal objects between the Communicator and the Tag in the position(s) where communication is to take place.
- Ensure that the Tags and Readers are aligned according to the project documentation. Maximum communication distances and communication paths are achieved when Tag and Readers are in parallel. Communication at maximum specified distance and misalignment should be avoided.
- Ensure that the Readers are not placed in positions, where they are exposed to unnecessary heat or electromagnetism.

8.3 Verifying communication

8.3.1 Serial host communication

Connect a PC to the prepared host connection and verify that the PC can communicate with the Communicator. If the actual Communicator is a standard S1500/S1503 equipped with Pyramid software this can be made by using the TagMaster demo software Saccess that runs under DOS, Windows 3.1, 95/98/ME and NT/2000/XP. An alternative to Saccess is the TagMaster test software ConfiTalk Commander which can be used for any Communicator where the resident software was developed using ConfiLib and where ConfiTalk is enabled, for example the S1501 with Solid software. A final verification should be made using the actual host project software.

8.3.2 Communicator - Tag communication

Put a Tag in front of the Communicator preferably having the Tag on the object where it normally will be mounted. Perform repeated Tag readings when simultaneously moving the Tag along the expected movement path and checking that the Tag can be read in all expected positions.

If the actual Communicator is a standard S1500/1503/S1513, the repeated readings can be made by using the TagMaster demo software Saccess that runs under DOS, Windows 3.1, 95/98/ME and NT/2000/XP and perform "read-beep". This puts the Communicator in a mode where it makes repeated Tag readings and beeps the buzzer for each OK-read. The beep should be "homogenous" for all expected positions along the movement path.

An alternative, which can be used in case the Communicator is a standard S1501/S1504/S1514, is to use the terminal interface "Check-SW" and observe the read results on the screen. It must be possible to read the Tag in all expected positions along the expected movement path. For detailed information concerning how to use Check-SW please refer to the manual TagMaster Programmer's Guide.

Special care should be taken if metal is present close to the communication lobe between Tag and Communicator. In such cases adjustment of the Tag/Communicator position and distance may be necessary to find the best location of the both. Always combine this with repetitive Tag read tests to verify that the installation works well.

If the Communicator is installed with a low grazing angle to a reflecting surface such as a road or floor, the multipath effect can increase the reading distance. Since the multipath effect may as well reduce the lobe width, a repetitive Tag read test is recommended to check the communication in such installations. If Tags are passing at a close distance from the Communicator it might be necessary to reduce the reading range to avoid unwanted readings of remote Tags. The range is reduced by setting of the power and sensitivity parameters.

8.3.3 Digital I/O - communication with external devices

The method for checking the digital I/O depends on the software application.

If the customer makes the software application, then the I/O devices must be tested from the host project software. If the Communicator is a standard S1500 with Pyramid software, digital I/O can be checked directly from the Saccess demo-software. An alternative that can be used for both the Communicator S1501 with Solid software and S1500/S1503 with Pyramid software is to use the I/O commands in the terminal interface "Check-SW" and observe the results. For detailed information concerning how to use Check-SW please refer to the manual 'TagMaster Programmer's Guide'.

9 TROUBLE SHOOTING

This section describes problems commonly encountered during system start up

9.1 An S1500/S1503/S1513 communicator seems not to read Tags

If the Pyramid software in S1500 is used in the operational mode (OP) = On then the Pyramid software will try to fetch all Tag read results. Pyramid does this by making use of the ConfiLib function Bsw_Event_Handler_Get_Event. If a PC resident software application also tries to fetch read results using the ConfiLib function Bsw_Event_Handler_Get_Event then the PC software will often not get any. Therefore, in order to make it possible for a PC resident software to fetch read results from the communicator using the ConfiLib function Bsw_Event_Handler_Get_Event, then the operational mode (OP) must be switched = Off.. This is done via the control panel or via the Saccess PC-demo software.

9.2 Unsuitable interface converters

Connecting RS232/RS85 converters to the Communicator port A or B requires intelligent converters i.e. converters that can switch between receive and transmit dependent of the information flow direction.

9.3 Interference

If more than one Communicator are used in closed vicinity of each other, they must be set to different RF channels. Neglecting to do this will reduce communication range.

9.4 Using wrong address

When one host in a polled network controls many Readers, different Communicator addresses must be used. Neglecting this will cause serious communication problems in the network.

9.5 Forgetting the free-wheel diode across inductive loads

Inductive loads connected to the Communicator digital and relay outputs must be provided with a free-wheel-diode to prevent malfunction or damage of the Communicator.

9.6 Using different data speed in the Tag(s) and in the Communicator(s).

A Communicator operating at high data speed cannot communicate with Tags set to low data speed and vice versa.

9.7 Using an unsuitable power supply

If an unsuitable power supply is used for powering the Readers the Communicator functions may be unreliable. In worst case the Communicator does not work at all. The power supply used for a TagMaster Communicator must deliver a DC power according to following specifications:

Power supply type	Voltage limits	min DC-current
24VDC	20 - 28 Volt	200 mA
12VDC	10 - 14 Volt	550 mA

The voltage from the power supply must stay within the specified limits all the time. This also includes a possible ripple-voltage from the power supply.